

---

**GROUP 37**

**POWER STEERING**

**CONTENTS**

<b>GENERAL INFORMATION .....</b>	<b>37-2</b>	<b>OIL PUMP.....</b>	<b>37-7</b>
<b>STEERING WHEEL.....</b>	<b>37-3</b>	<b>STEERING GEAR.....</b>	<b>37-7</b>
<b>STEERING SHAFT AND COLUMN..</b>	<b>37-4</b>	<b>OIL RESERVOIR .....</b>	<b>37-8</b>

## GENERAL INFORMATION

M2370000101478

The hydraulic power steering system has been adopted.

The steering system offers the following features.

- The support method of the steering gear to the crossmember is realized by the left and right bushings with inner cylinders for improved steering feeling.
- The AWC switch has been installed on the steering wheel top surface for improved convenience.
- For some models, the steering wheel audio remote control switch and steering wheel voice control switch have been established for improved convenience.
- The variable flow pump, which reduces the engine loss by controlling the flow amount necessary for driving straight ahead or cornering, has been adopted.
- The flexible tube length in the high pressure hose has been optimized for reducing the pump noise.
- The reservoir tank already adopted for Outlander has been adopted, and the baffle plate inside the cap has been improved to prevent oil leakage under the high load condition.

## SPECIFICATIONS

Item		Specifications
Steering wheel	Shape	Three-spoke type
	Outer diameter mm (in)	365 (14.3)
	Maximum number of rotation	2.27
Power steering type		Integral type (Engine speed-dependent type)
Oil pump	Shape	Vane type with fluid flow amount control system
	Basic discharge rate cm <sup>3</sup> /rev. (cu in/rev)	9.0 (0.55)
	Relief pressure MPa (psi)	8.55 (1.197)
	Reservoir type	Separation type (Resin made)
Steering gear and linkage	Shape	Rack and pinion type
	Stroke ratio (rack stroke/number of steering wheel rotation) mm/rev (in/rev)	65.97 (2.59)
	Rack stroke mm (in)	150 (5.9)
Steering angle	Inside wheel	33°
	Outside wheel	28°

CONSTRUCTION DIAGRAM

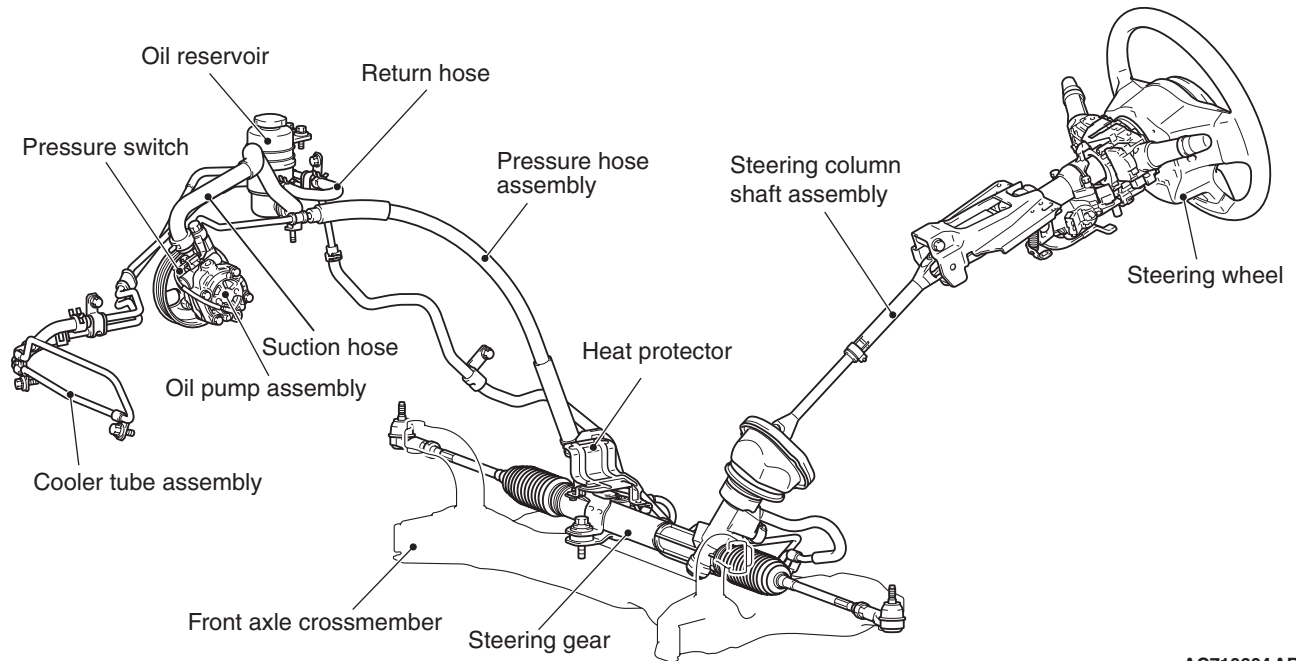

AC710604 AB

STEERING WHEEL

M2370001001087

<Equipped with AWC switch>

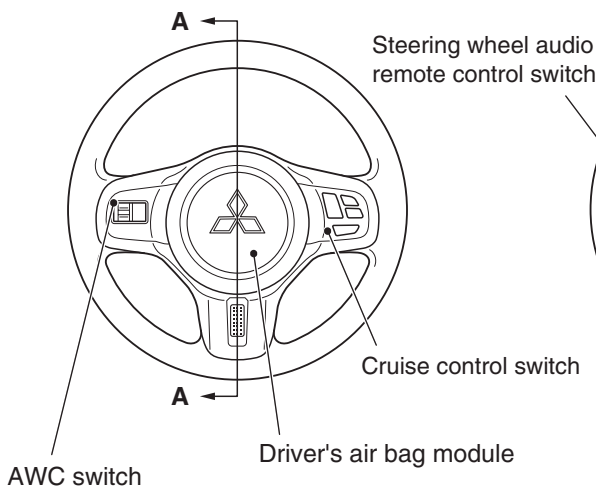

<Equipped with steering wheel remote control switch>

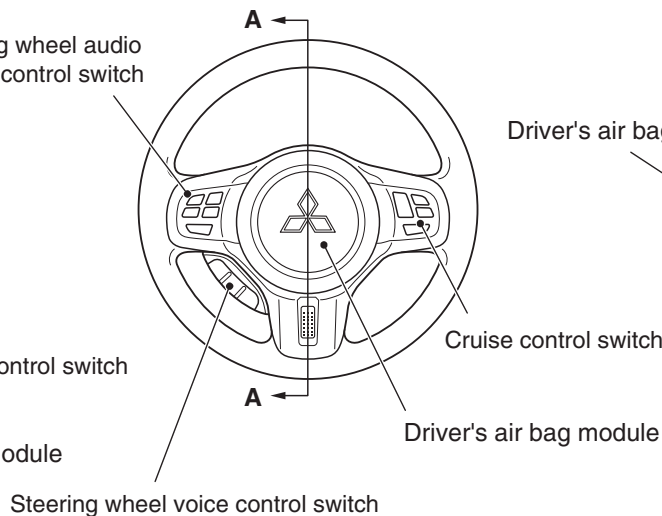

Section A - A

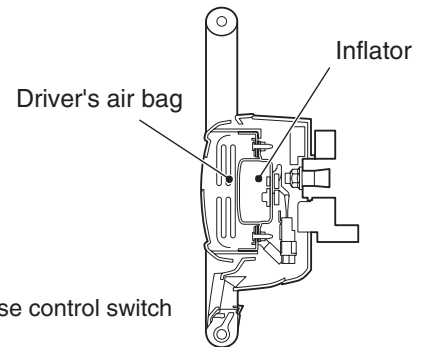

AC708297 AB

The steering wheel is designed to improve operability and safety, and has the following features.

- The genuine leather 3-spoke type has been adopted.
- The AWC switch has been installed on the steering wheel top surface.
- For some models, the steering wheel audio remote control switch and steering wheel voice control switch have been established for improved convenience.
- In addition to the round module pad which gives a sporty image, the integrated garnish has been employed for better appearance.
- The small-diameter steering wheel suitable for the sport drive has been adopted.
- The dual inflator has been adopted, which detects the impact exceeding a certain level upon collision, and controls the airbag deployment depending on the impact severity.

## STEERING SHAFT AND COLUMN

M2370002000924

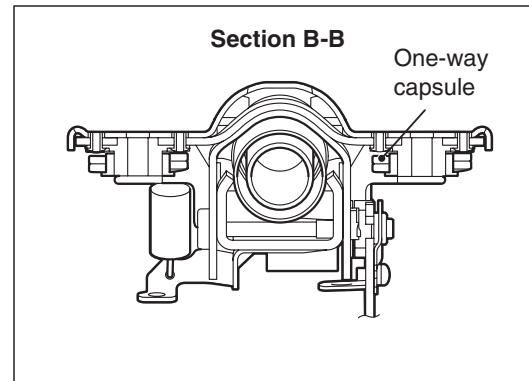
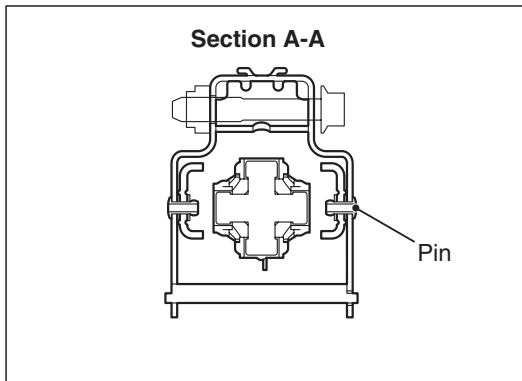
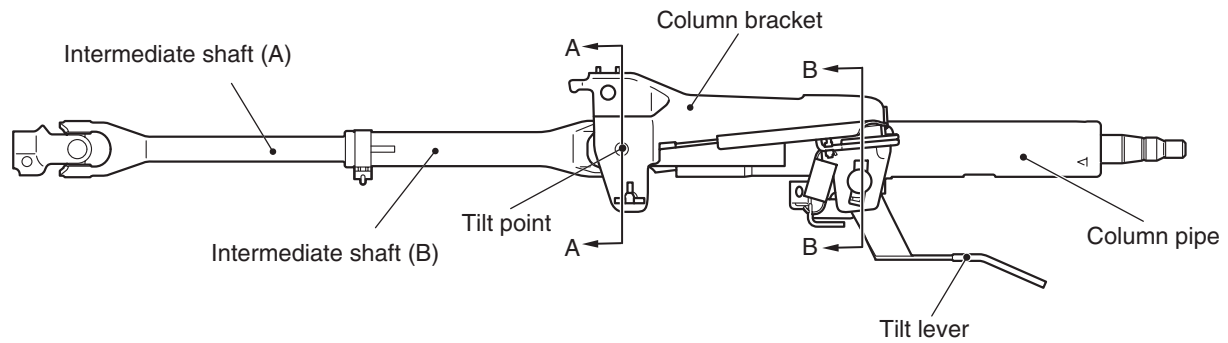

AC708298 AB

The steering column shaft is designed to improve operability and safety, and has the following features.

- The steering column layout has been optimized for better steering feeling (reduction of torque fluctuation) covering the whole tilting range.
- The collapsible steering column, with which the steering wheel moves forward on a collision, has been employed for improvement of passenger safety.

## ENERGY ABSORBING MECHANISM

### PRIMARY COLLISION

When a vehicle is crashed and the load is applied to the lower shaft from the gearbox side, the intermediate shaft (A) is forced into the intermediate shaft (B) to absorb the impact load.

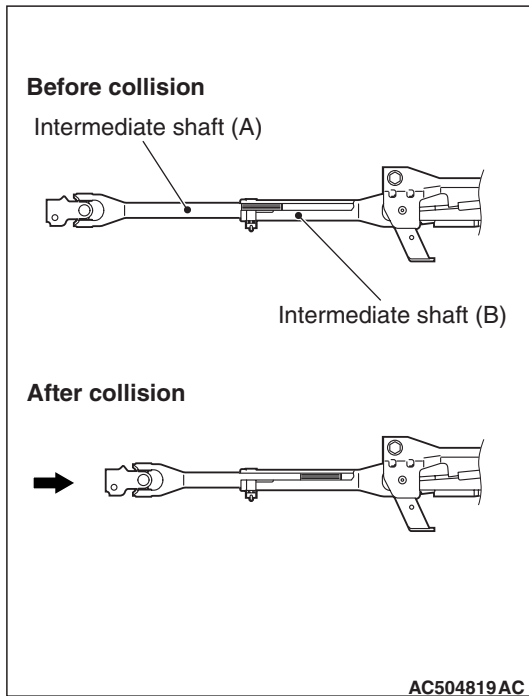

**SECONDARY COLLISION**

When the load of the driver's body is applied to the steering wheel after the airbag deployment, the column pipe is separated from the column bracket for reducing the impact applied to the driver.

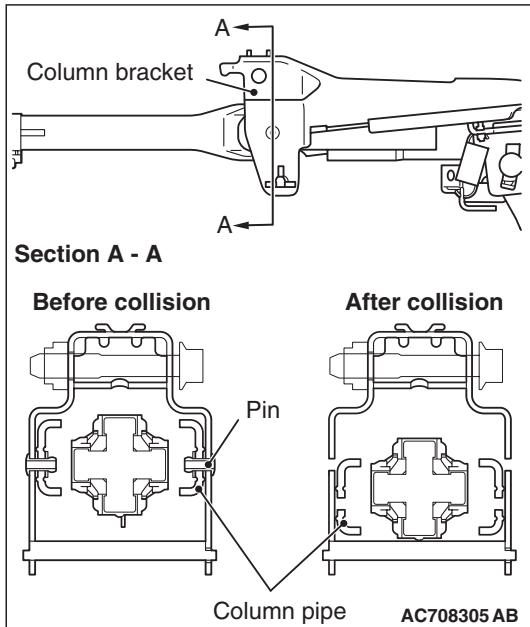
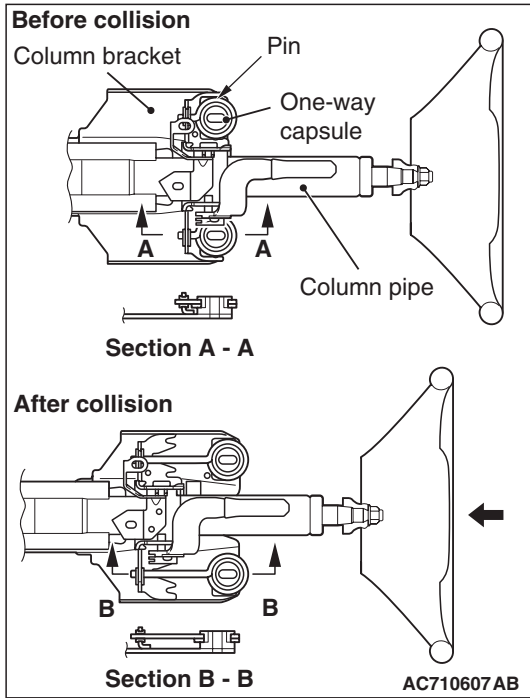

## OIL PUMP

M2370004000544

The oil pump is a vane type with a fluid flow control system which functions so the steering wheel turning effort will be reduced at low engine speeds and increase at higher speeds.

The oil pump is essentially the same as the conventional one in construction.

## STEERING GEAR

M2370003000756

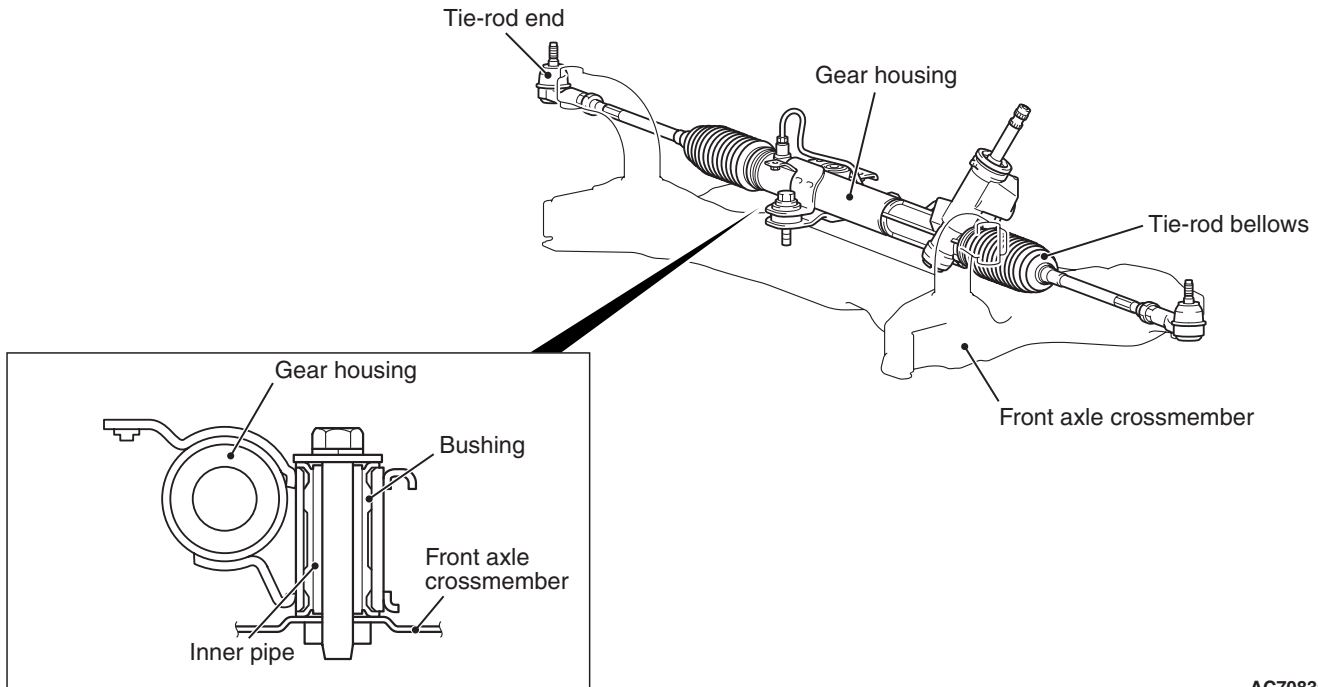

AC708300AB

The steering gear and linkage is mounted on the front axle crossmember via three bushings with inner cylinders, and has the following features.

- The bushing with inner cylinder supports the steering gear and linkage in the vertical and fore-and-aft direction with high rigidity, and considerably improves the steering feeling.

**OIL RESERVOIR**

M2370005000547

The resin oil reservoir is used to reduce weight. The oil reservoir is translucent and has fluid level marks (MAX and MIN lines), facilitating inspection.

