GROUP 35A**BASIC BRAKE
SYSTEM****CONTENTS**

GENERAL DESCRIPTION.....	35A-2	BRAKE BOOSTER	35A-4
CONSTRUCTION DESCRIPTION ...	35A-4	BRAKE PEDAL	35A-4
		BRAKE	35A-6

GENERAL DESCRIPTION

M2350000101238

The brake system has high reliability and durability, and provides an exceptional braking performance.

FEATURES

IMPROVED BRAKING PERFORMANCE

- In addition to the 10-inch through bolt type single brake booster, the small and long stroke-type master cylinder is adopted to provide rigidity, to reduce weight, and to secure the assist force.
- Brembo™ 18-inch 4-pot front ventilated disk brakes and Brembo™ 17-inch 2-pot rear ventilated disk brakes are adopted to provide stable braking force and improved braking feel.
- To the front, two-piece structure brake disk is installed. <GSR: Option, MR: Standard>

IMPROVED STABILITY

- Front- and rear-wheel X-type brake line layout is used.
- The brake pedal retreat suppression mechanism that suppresses the retraction of brake pedal surface upon a frontal collision is adopted.
- To the front brake and rear brake, the brake pads with audible wear indicator are adopted which warn the driver of the wear limit.

CONSTRUCTION DIAGRAM

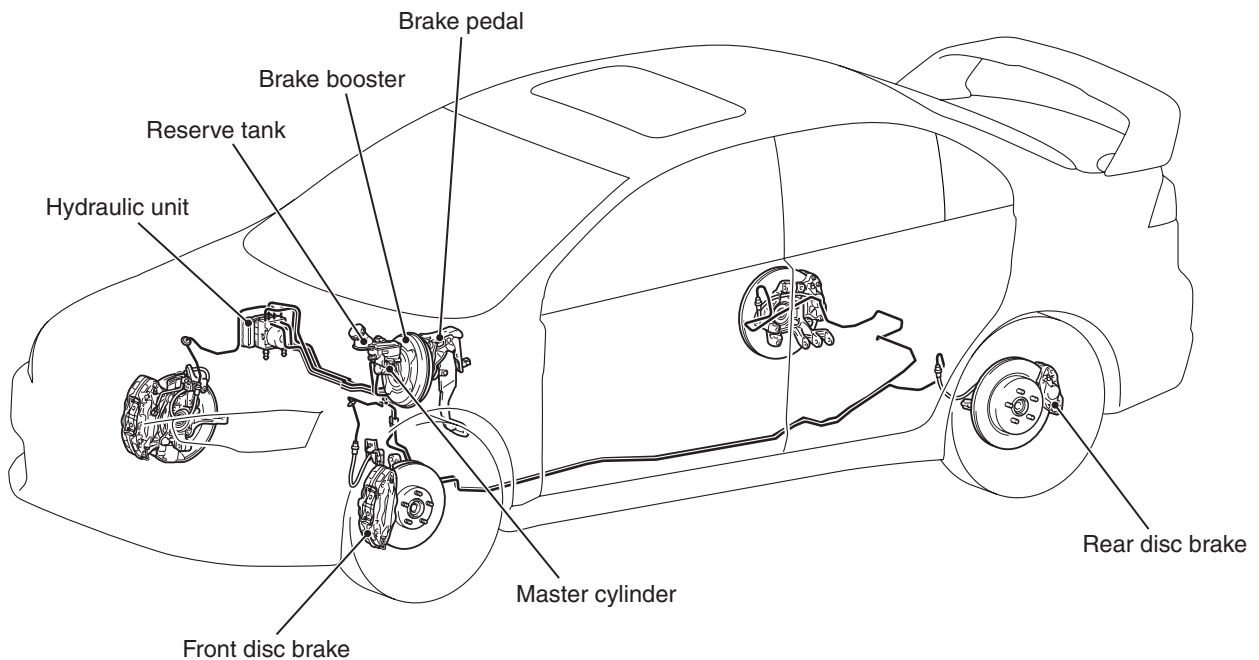

AC708805AB

SPECIFICATIONS

Item		Specification
Master cylinder	Type	Tandem type
	I.D. mm (in)	23.81 (0.94)
Brake booster	Type	Vacuum type, single
	Effective dia. of power cylinder mm (in)	252 (10)
	Boosting ratio	5.5 {Pedal depression force: 663 N (149 lb)}
Front brakes	Type (Disk brake nomenclature)	Brembo™ 4-opposed-piston ventilated disk (V8-Z4046)
	Disk effective dia × thickness mm (in)	294 × 32 (11.6 × 1.3)
	Cylinder I.D. mm (in)	40.0 (1.58) × 2, 46.0 (1.81) × 2
	Brake pad thickness mm (in)	9.85 (0.39)
	Clearance adjustment	Automatic adjustment
Rear brakes	Type (Disk brake nomenclature)	Brembo™ 2-opposed-piston ventilated disk (V7-X40)
	Disk effective dia × thickness mm (in)	278 × 22 (10.9 × 0.9)
	Cylinder I.D. mm (in)	40.0 (1.58) × 2
	Brake pad thickness mm (in)	9.0 (0.35)
	Clearance adjustment	Automatic adjustment
Brake fluid		DOT3 or DOT4

CONSTRUCTION DESCRIPTION

BRAKE BOOSTER

M2350002000892

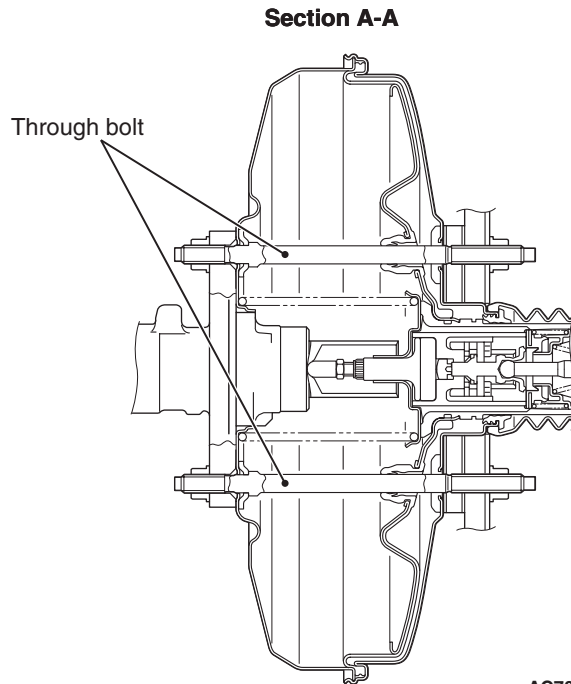
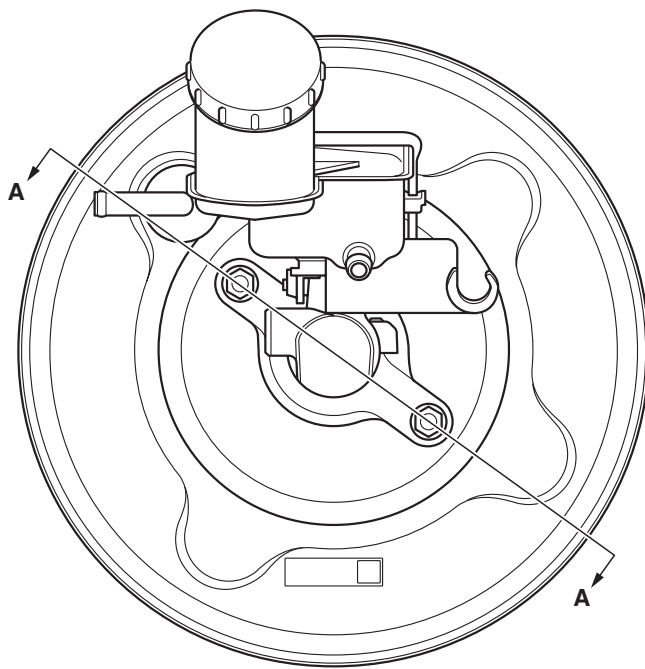

AC708806AB

10-inch through bolt type single brake booster is installed.
With the brake booster, two through bolts are used to improve surface rigidity of the booster. The master cylinder and brake pedal are mounted to each end of the bolt. When the brake pedal is depressed forcefully, the forward movement of master cylinder assembly is suppressed, improving brake feeling.

BRAKE PEDAL

BRAKE PEDAL PAD

M2350007000488

<M/T>

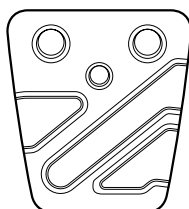

<TC-SST>

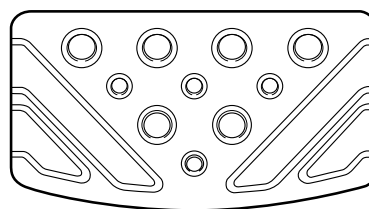

AC708807AB

The aluminum pedal pad has been adopted to the brake pedal in order to enhance the sporty image.

BRAKE PEDAL RETREAT SUPPRESSION MECHANISM

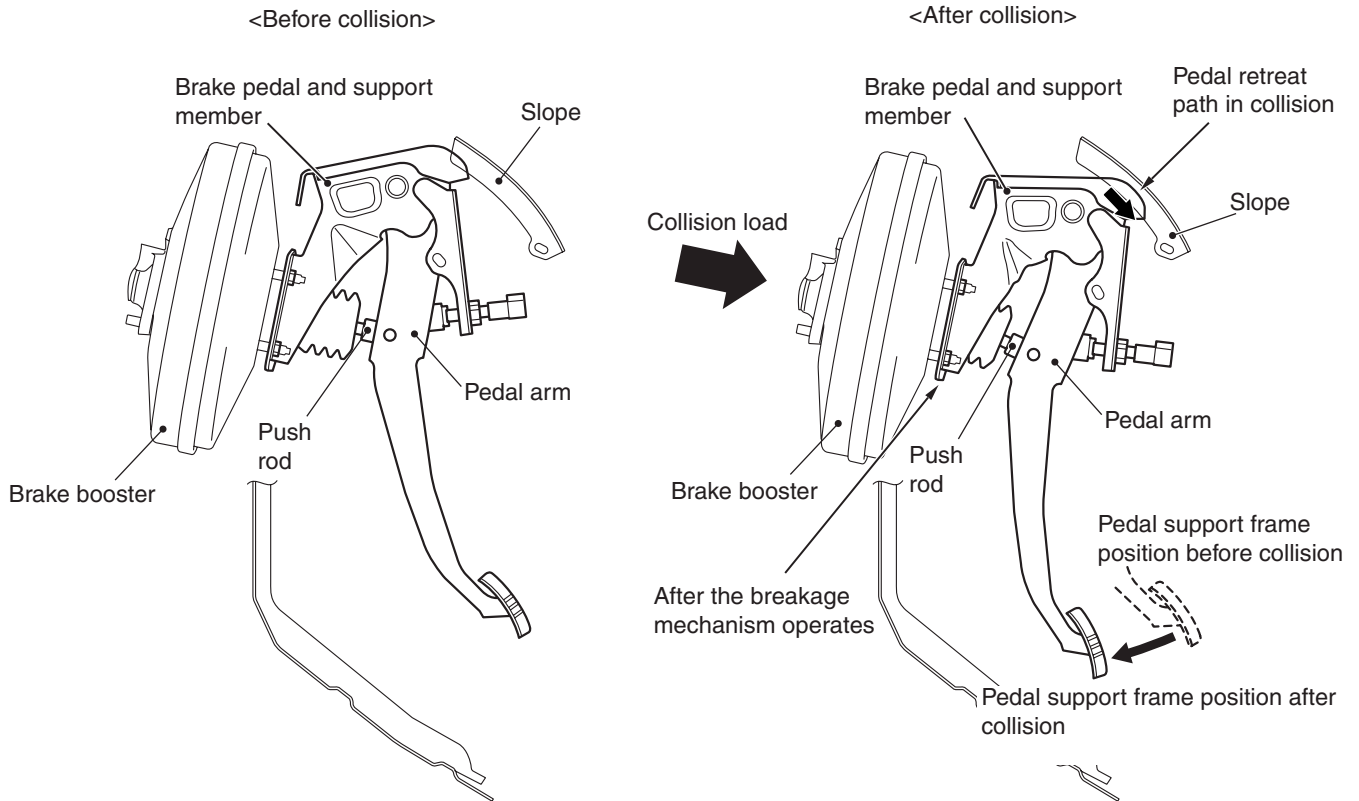

AC611958AB

The brake pedal retreat suppression mechanism that restrains the retraction of the brake pedal pad surface during a frontal collision has been adopted in order to reduce the shock to the driver's feet.

When the brake booster is crushed rearward by the engine retreat during a frontal collision, the installation surface of the brake pedal is retreated. In this case, the end of the pedal support is forcibly slid down and back by the interference with the slope mounted on the front deck crossmember assembly. At the same time, the linkage comprised of the pedal support, pedal arm, and push rod moves the brake pedal pad surface forward.

BRAKE

M2350004100066

<GSR>

<Standard>

Front <18-inch disk brake (V8-Z4046)>

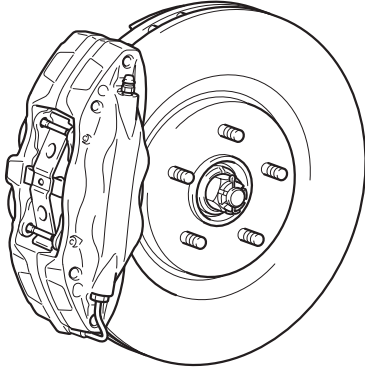

Rear <17-inch disk brake (V7-X40)>

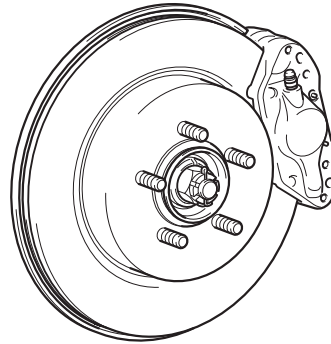

<Option>

Front <18-inch disk brake (V8-Z4046) and
2-piece structure brake disk>

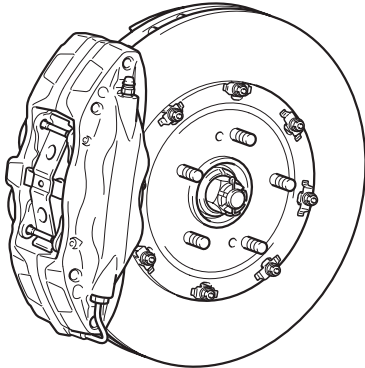

AC707846AB

<MR>

Front <18-inch disk brake (V8-Z4046) and
2-piece structure brake disk>

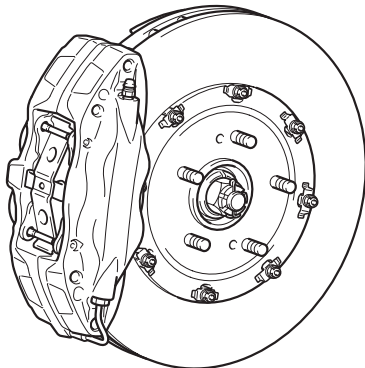

Rear <17-inch disk brake (V7-X40)>

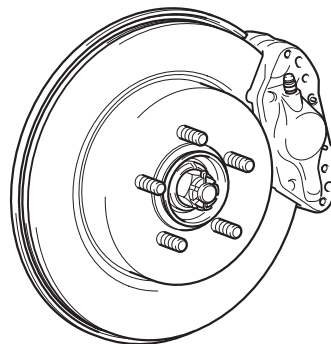

AC708808AB

TWO-PIECE STRUCTURE BRAKE DISK

Brake disk (2-piece structure)

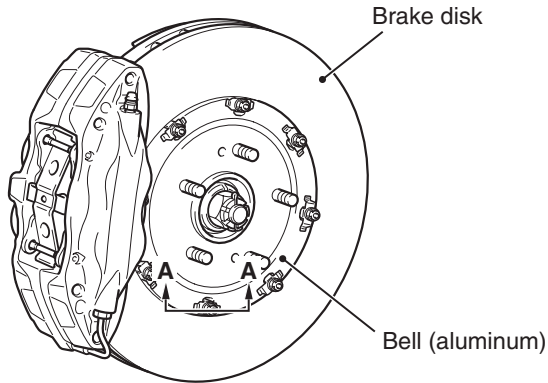

Section A-A

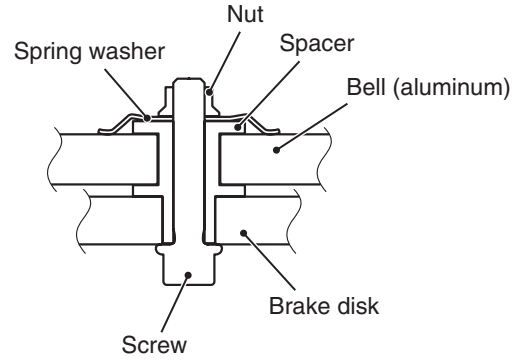

AC710718AB

The brake offering the following features is installed.

- To both the front brake and rear brake, the brake pads with audible wear indicator are adopted which warn the driver of the wear limit.
- To the front, two-piece structure 18-inch brake disk is installed for weight reduction (weight reduction of 1.3 kg (2.9 lbs). <GSR: Option, MR: Standard>

DISK BRAKE NOMENCLATURE

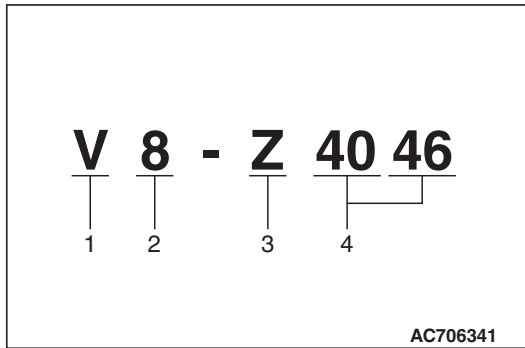

NO.	ITEM	CONTENT
1	Brake disk type	V: Ventilated
2	Brake size (Minimum applicable disk wheel)	7: 17-inch 8: 18-inch
3	No. of pistons	X: 2-piston (opposed type) Z: 4-piston (opposed type)
4	Piston size (rounded to nearest integer)	40: ϕ 40 mm (1.6 in) 46: ϕ 46 mm (1.8 in)

NOTES