

GROUP 00E

GENERAL <ELECTRICAL>

CONTENTS

HARNES CONNECTOR INSPECTION	00E-2	INSPECTION INSTRUMENTS	00E-7
HOW TO DIAGNOSE	00E-6	CHECKING FUSES	00E-9
HOW TO DIAGNOSE	00E-6	CHECKING SWITCHES	00E-10
TROUBLESHOOTING STEPS	00E-6	CHECKING RELAYS	00E-11
INFORMATION FOR DIAGNOSIS	00E-6	CABLES AND WIRES CHECK	00E-12
INSPECTION	00E-7	BATTERY HANDLING	00E-12
		GENERAL ELECTRICAL SYSTEM CHECK	00E-12

HARNESS CONNECTOR INSPECTION

M1001003900201

CONNECTOR CONTINUITY AND VOLTAGE TEST

Required Special Tools:

- MB991219: Test Harness Set
- MD998459: Test Harness

Follow the steps below to avoid causing poor connector contact and/or reduced waterproof performance of connectors when checking continuity and/or voltage at waterproof connectors.

⚠ CAUTION

Never backprobe a waterproof connector. Backprobing a connector may cause the terminals to corrode, deteriorating circuit performance.

1. If the circuit to be checked is a closed state, use a special tool like MD998459.

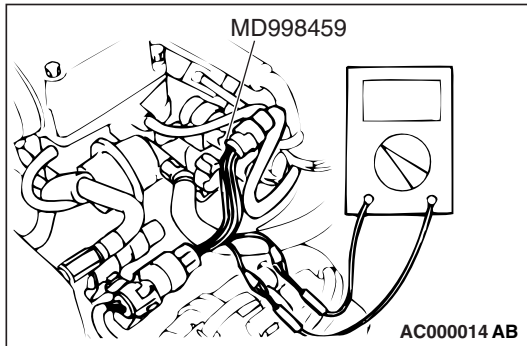

⚠ CAUTION

Forcing the probe into the terminal may open the terminal, causing intermittent or poor contact and creating an open circuit.

2. If the connector is disconnected for checking and the facing part is the female pin side, use an appropriate male terminal for checking the contact pressure of connector pins (like MB991219).

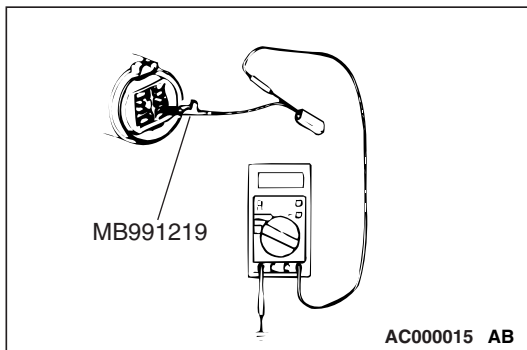

⚠ CAUTION

Do not simultaneously contact more than one terminal with the probe. Contacting two or more terminals at the same time may damage a circuit, possibly to the point of starting an electrical fire.

3. If the facing part is the male pin side, either carefully touch the probe to the pin so it does not accidentally contact other pins, or use an appropriate female terminal.

IMPROPER TERMINAL ENGAGEMENT CHECK

Terminals inside a connector may not engage properly even if the connectors engage. Make sure that each terminal does not come out of the connector when gently pulling each harness wire. If it does, repair or replace the terminal and/or connector.

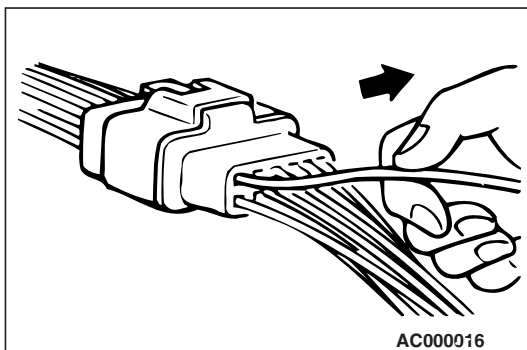

CONNECTOR TERMINAL ENGAGEMENT AND DISENGAGEMENT

Loosely engaged terminals can be repaired by removing the female terminal from the connector housing and raising its lance to establish better engagement. Removal of the connector terminal used for MFI and INVECS-II A/T control circuit can be done in the following manner.

COMPUTER CONNECTOR

1. Insert a screwdriver [1.4 mm (0.06 inch) width] as shown in the figure, disengage the front holder, and remove it.

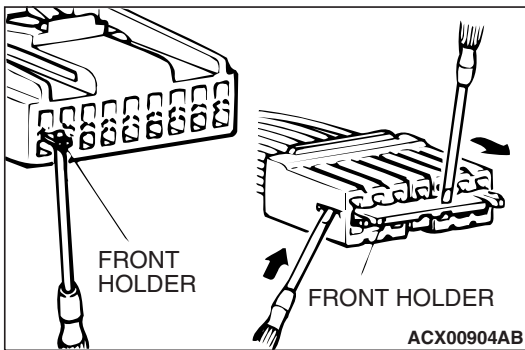

2. Push the harness wire of the terminal to be repaired deep into the connector from the harness side and hold it there.

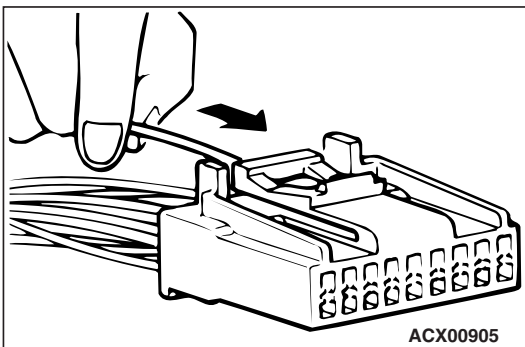

3. Insert the tip of the screwdriver [1.4 mm (0.06 inch) width] into the connector as shown in the figure, gently push the housing lance down with the tip, and pull out the terminal.

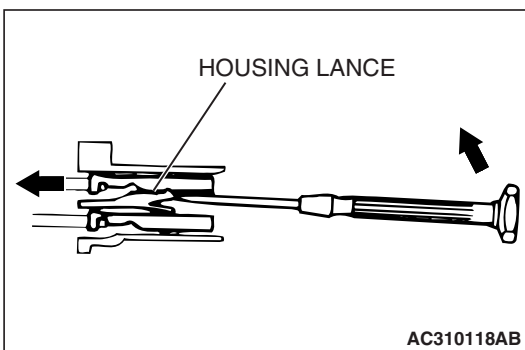

4. Insert a needle through the hole provided on the terminal and raise the contact point. Lightly squeeze the outer edge so the flats are parallel with the bottom.

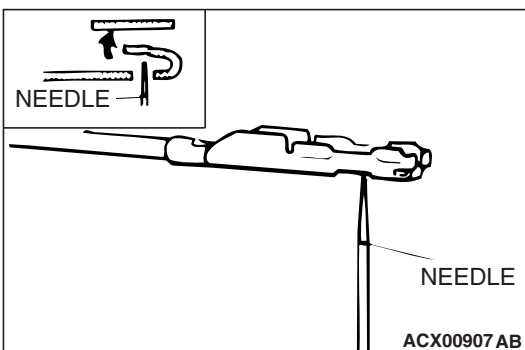

ROUND WATERPROOF CONNECTOR

1. Remove the waterproof cap by using a screwdriver.
2. Insert the tip of the screwdriver [1.4 mm (0.06 inch) or 2.0 mm (0.08 inch) width] into the connector as shown in the figure, raise the housing lance slightly with the tip, and pull out the terminal.

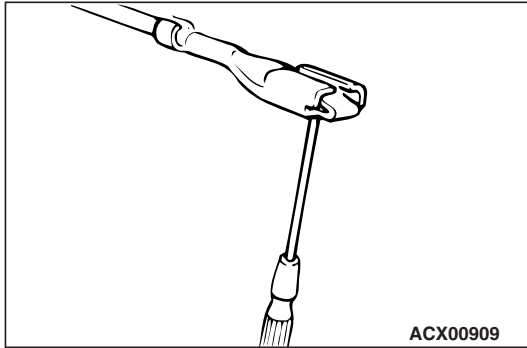
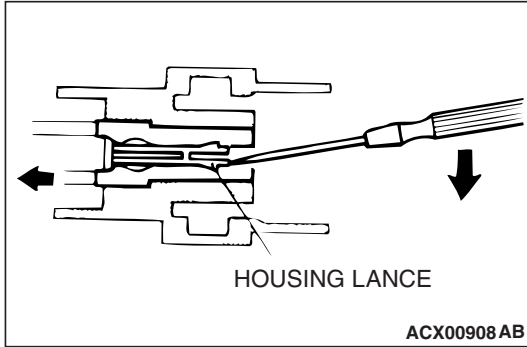

3. Insert a screwdriver through the hole provided on the terminal and raise the contact point. Lightly squeeze the outer edge so the flats are parallel with the bottom.

RECTANGULAR WATERPROOF CONNECTOR

1. Disengage the front holder with a screwdriver and remove it.

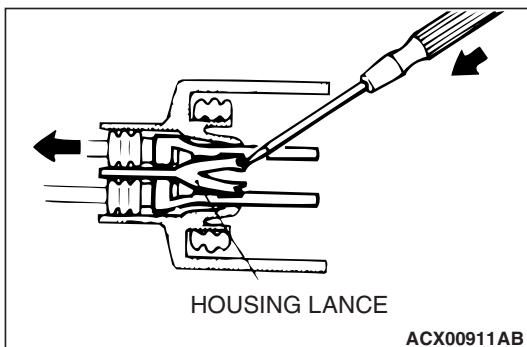
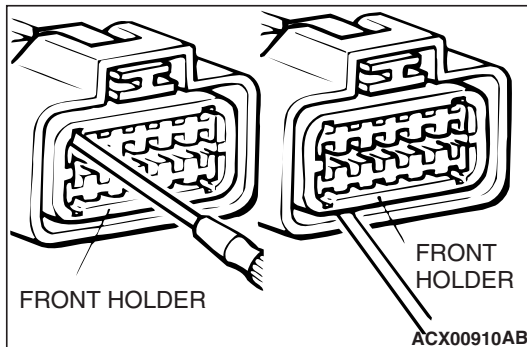

2. Insert the tip of a screwdriver [0.8 mm (0.03 inch) width] into the connector as shown in the figure, push it lightly to raise the housing lance, and pull out the terminal.

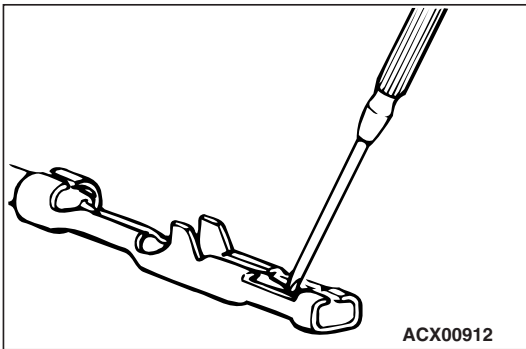

3. Press the contact point to the male terminal down by holding a screwdriver [1.4 mm (0.06 inch) width] as shown in the figure. Lightly squeeze the outer edge so the flats are parallel with the bottom.

INJECTOR CONNECTOR

1. Remove the waterproof cap.

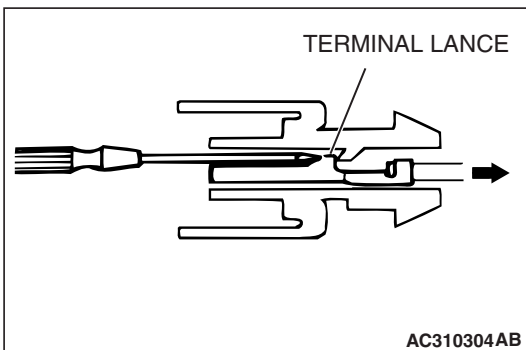
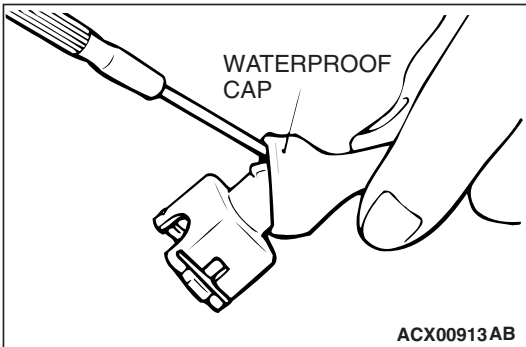

2. Insert the tip of a screwdriver [1.4 mm (0.06 inch) width] into the connector as shown in the figure, press in the terminal lance, and pull out the terminal.

⚠ CAUTION

Make sure the lance is pressed in before the terminal is inserted into the connector.

3. Press the contact point to the male terminal down by holding a screwdriver [1.4 mm (0.06 inch) width] as shown in the figure.

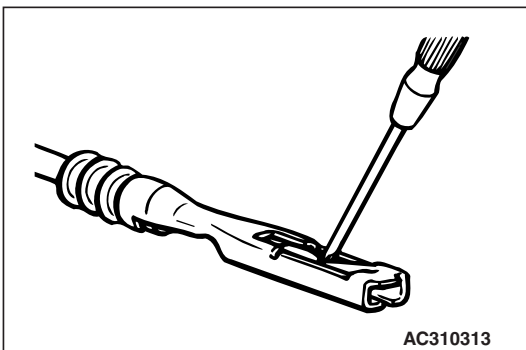

HOW TO DIAGNOSE

HOW TO DIAGNOSE

M1001004300086

The most important point in troubleshooting is to determine "Probable Cause." Once the probable causes are determined, parts to be checked can be limited to those associated with such probable causes. The determination of the probable causes must be based on a theory and be supported by facts and must not be based on intuition only.

TROUBLESHOOTING STEPS

M1001004400049

If an attempt is made to solve a problem without going through correct steps for troubleshooting, the symptoms could become more complicated, resulting in failure to determine the causes correctly and making incorrect repairs. The four steps below should be followed in troubleshooting.

1 Observation of Problem Symptoms

Observe the symptom carefully. Check if there are also other problems.



2 Determination of Probable Causes

In determining the probable causes, it is necessary to study the wiring diagram to understand the circuit as a system. Knowledge of switches, relays and other parts is necessary for accurate analysis. The causes of similar problems in the past must be taken into account.



3 Checking of Parts Associated with Probable Causes and Determination of Faulty Parts

Troubleshooting is carried out by making step-by-step checks until the cause is found.



4 Repair and Confirmation

After the problems are corrected, be sure to check that the system operates correctly. Also check that new problems have not been caused by the repair.

ACX00915AC

INFORMATION FOR DIAGNOSIS

M1001004500132

This manual contains the harness diagrams as well as the individual circuit drawings, operational explanations, and troubleshooting hints for each component. The information is presented in the following manner:

1. Connector diagrams show the connector positions, etc., on the actual vehicle as well as the harness path.
2. Circuit diagrams show the configuration of the circuit with all switches in their normal positions.
3. Operational explanations include circuit drawings of current flow when the switch is operated and how the component reacts.

4. Troubleshooting hints include numerous examples of problems which might occur, traced backward in a common-sense manner to the origin of the trouble. Problems whose origins may not be found in this manner are pursued through the various system circuits.

NOTE: Components of MFI, ETACS, etc. with ECU do not include 3 and 4 above. For this information, refer to a relevant group which includes details of these components.

INSPECTION

M1001004600139

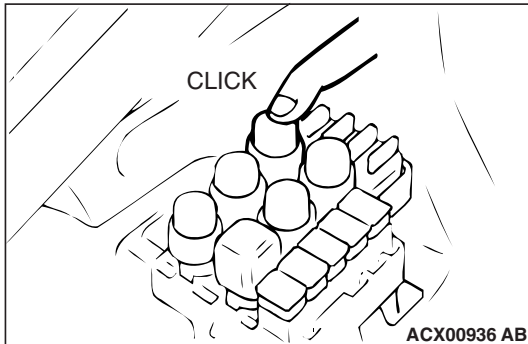

1. Sight and sound checks

Check relay operation, blower motor rotation, light illumination, etc. Listen for a "click" when some relay covers are pushed down.

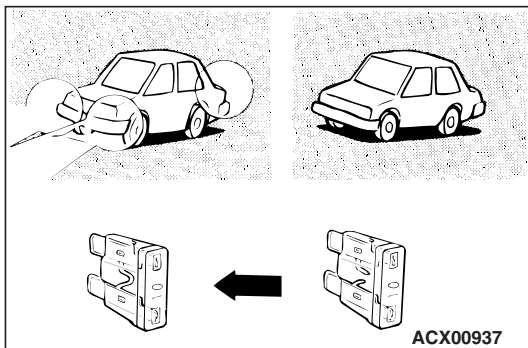

2. Simple checks

For example, if a headlight does not come on and a faulty fuse or poor grounding is suspected, replace the fuse with a new one. Or use a jumper wire to ground the light to the body. Determine which part(s) is/are responsible for the problem.

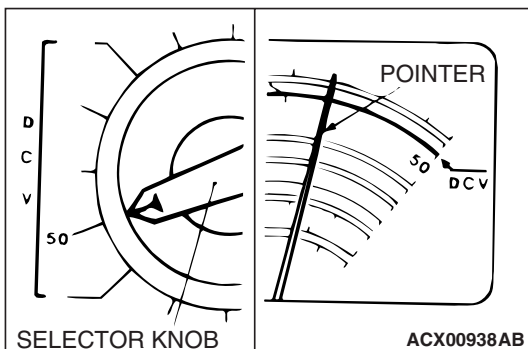

3. Checking with instruments

Use an appropriate instrument in an adequate range and read the indication correctly.

INSPECTION INSTRUMENTS

M1001004700040

For inspection, use the following instruments:

⚠ CAUTION

Never use a test light for checking ECU-related circuits or ECUs.

1. Test light

A test light consists of a 12V bulb and lead wires. It is used to check voltages or short circuits.

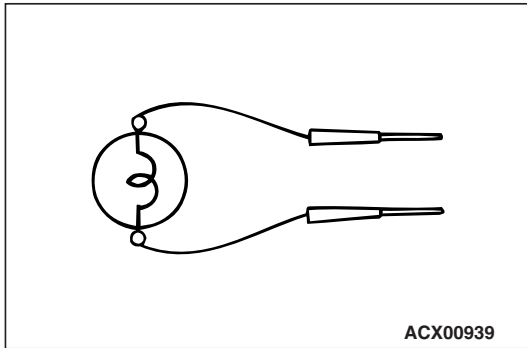

2. Self-powered test light

A self-powered test light consists of a bulb, battery and lead wires connected in series. It is used to check continuity or grounding.

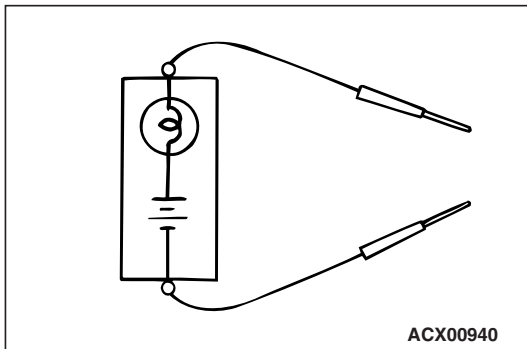
**⚠ CAUTION**

Never use a jumper wire to connect a power supply directly to a load.

3. Jumper wire

A jumper wire is used to close an open circuit.

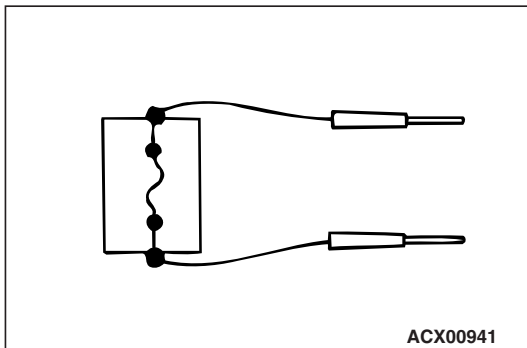

4. Voltmeter

A voltmeter is used to measure the circuit voltage. Normally, the positive (red lead) probe is applied to the point of voltage measurement and the negative (black lead) probe to the body ground. Use a digital voltmeter to check for voltage drop before or after a component.

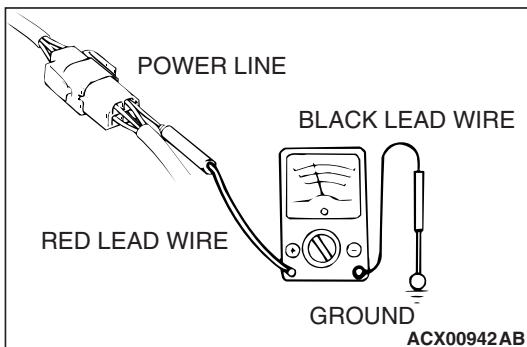

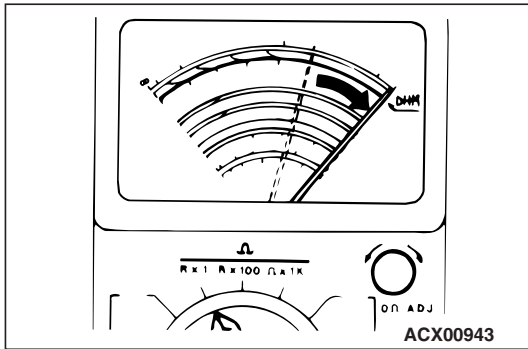

5. Ohmmeter

An ohmmeter is used to check continuity or measure resistance of a switch or coil. If the measuring range has been changed, the zero point must be adjusted before measurement.

CHECKING FUSES

M1001005000141

A blade type fuse has test taps provided to allow checking of the fuse itself without removing it from the fuse block. The fuse is okay if the test light comes on when its one lead is connected to the test taps (one at a time) and the other lead is grounded. Remember to turn the ignition switch to ON to ensure all circuits are live.

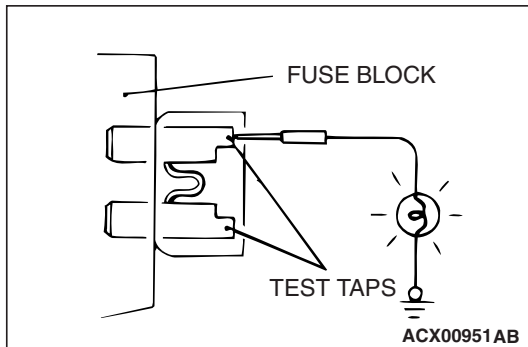

CAUTIONS IN EVENT OF BLOWN FUSE

When a fuse is blown, there are two probable causes. One is that it is blown due to flow of current exceeding its rating. The other is that it is blown due to repeated on/off current flowing through it. Which of the two causes is responsible can be easily determined by visual check as described below.

1. Fuse blown due to current exceeding rating

The illustration shows the state of a fuse blown due to this cause. In this case, do not replace the fuse with a new one hastily since a current heavy enough to blow the fuse has flowed through it. First, check the circuit for shorts and check for abnormal electric parts. After correcting shorts or replacing parts, use only a fuse of the same capacity as a replacement. Never use a fuse of larger capacity than the original fuse. If a larger capacity fuse is used, electric parts or wiring could be damaged, or could start a fire.

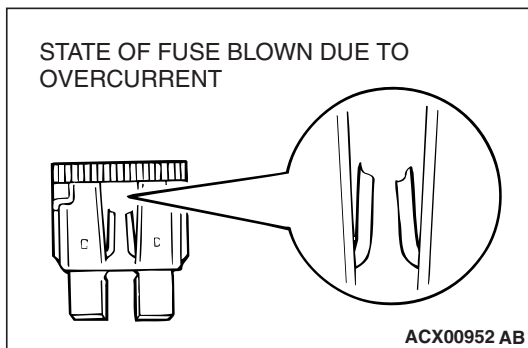

2. Fuse blown due to repeated turning current on and off

The illustration shows the state of a fuse blown due to repeated current on/off. Normally, this type of problem occurs after a fairly long period of use and is less frequent than above. In this case, simply replace with a new fuse of the same capacity.

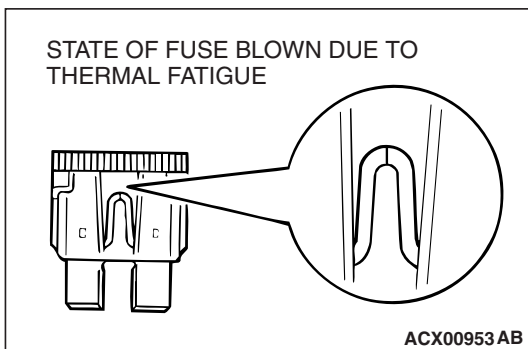

CHECKING SWITCHES

M1001004800177

In a circuit diagram, a switch is shown in the idle state.

1. Normally open or normally closed switch

Switches are classified into those which open the circuit and those which close the circuit when off.

Switches are shown in their normal state unless specified otherwise.

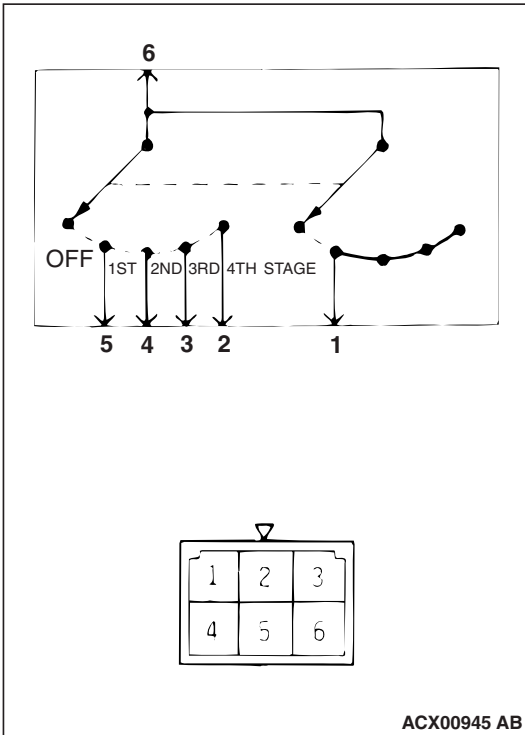
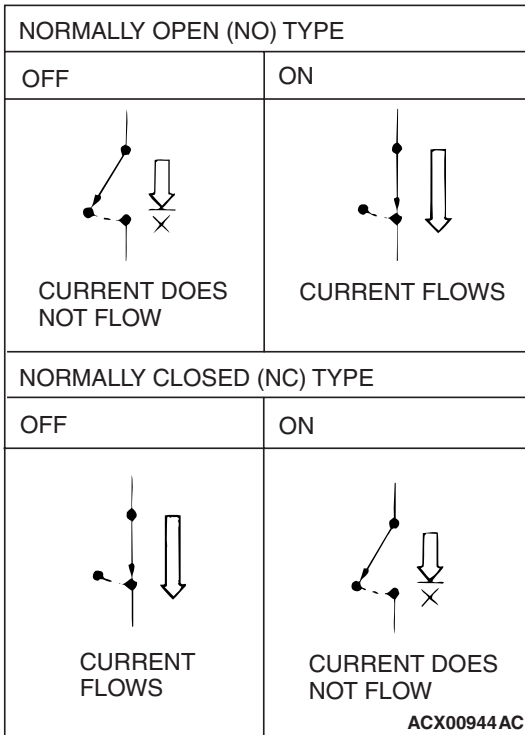

2. Switch connection

This figure illustrates a complex switch. The continuity between terminals at each position is as indicated in the table below.

SWITCH POSITION	TESTER CONNECTION	SPECIFIED CONDITION
OFF	—	—
1st stage	1-5-6	Continuity
2nd stage	1-4-6	Continuity
3rd stage	1-3-6	Continuity
4th stage	1-2-6	Continuity

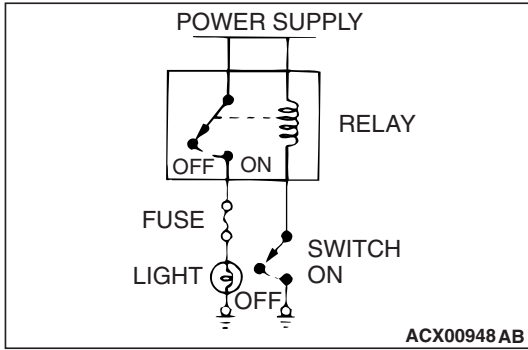

CHECKING RELAYS

M1001004900152

1. By using a relay, a heavy current can be turned on and off by a switch using much less current. For example, in the circuit shown here, when the switch is turned on (closed), current flows to the coil of the relay. Then, its contact is turned on (closed) and the light comes on. The current flowing through the switch is much less than that for the light.

2. When current flows through the coil of a relay, its core is magnetized to attract the iron piece, closing (ON) the contact at the tip of the iron piece. When the coil current is turned off, the iron piece returns to its original position by a spring, opening the contact (OFF).

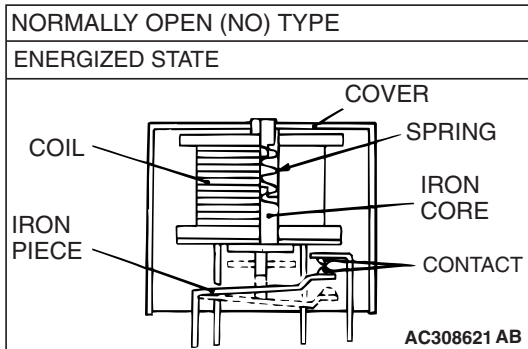

3. Relays may be classified as the normally open-type or the normally closed-type, depending on their contact construction.

NOTE: The deenergized state means that no current is flowing through the coil. The energized state means that current is flowing through the coil.

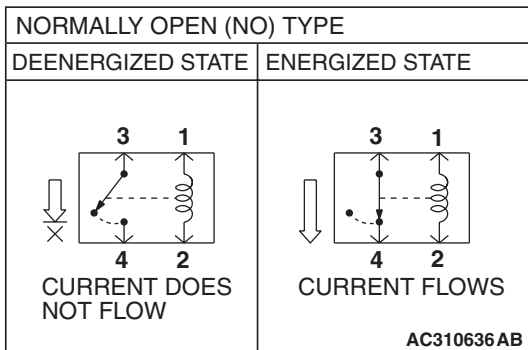

(1) The normally open-type

When a normally open relay as illustrated here is checked, there should be no continuity between terminals 3 and 4 when the relay is deenergized. There should be continuity between terminals 3 and 4 when battery voltage and ground are applied to terminals 1 and 2. The relay condition is determined by this check.

NOTE: Check the relay in both situation which is energized and is not energized.

(2) The normally closed-type

When a normally closed relay as illustrated here is checked, there should be continuity between terminals 3 and 4 when the relay is deenergized. There should be no continuity between terminals 3 and 4 when battery voltage and ground are applied to terminals 1 and 2. The relay condition is determined by this check.

NOTE: Check the relay in both situation which is energized and is not energized.

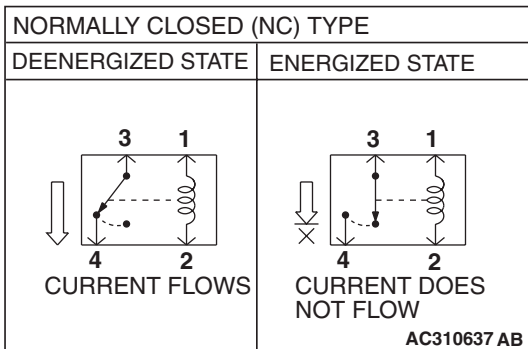

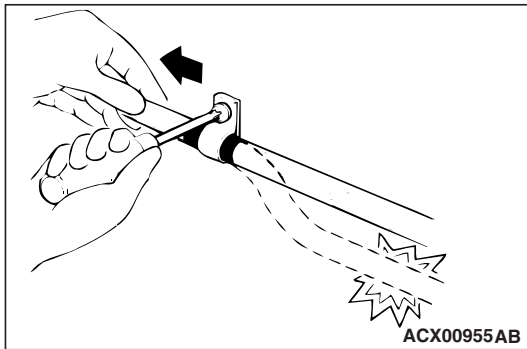
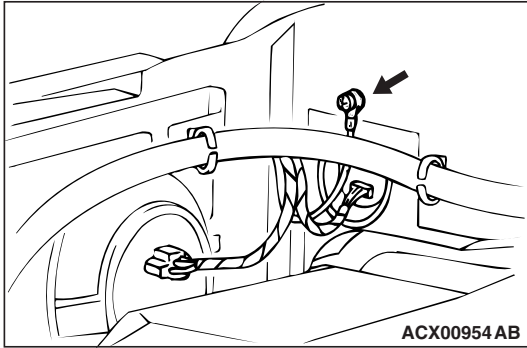

CABLES AND WIRES CHECK

M1001005100041

1. Check connections for looseness, rust, and stains.
2. Check terminals and wires for corrosion.
3. Check terminals and wires for open circuit or impending open circuit.
4. Check wire insulation and coating for damage, cracks, and wear.
5. Check conductive parts of terminals for contact with other metallic parts (vehicle body and other parts).
6. Check grounding parts to verify that there is complete continuity between attaching bolt(s) and vehicle body.
7. Check for incorrect wiring.
8. Check that harnesses are secured to prevent contact with sharp edges and corners or hot parts (exhaust manifold, pipe, etc.).
9. Check that harnesses are secured firmly to provide enough clearance from the fan pulley, fan belt, and other rotating or moving parts.
10. Check that the harnesses between fixed parts (such as the vehicle body) and vibrating parts (such as the engine) are long enough to allow for vibration and movement.

BATTERY HANDLING

M1001005200048

⚠ WARNING

Battery posts, terminals and related accessories contain lead and lead compounds. WASH HANDS AFTER HANDLING.

When checking or servicing does not require power from the vehicle battery, be sure to disconnect the cable from the battery (-) terminal. This will prevent problems that could be caused by a short circuit. Disconnect the (-) battery terminal first and reconnect it last.

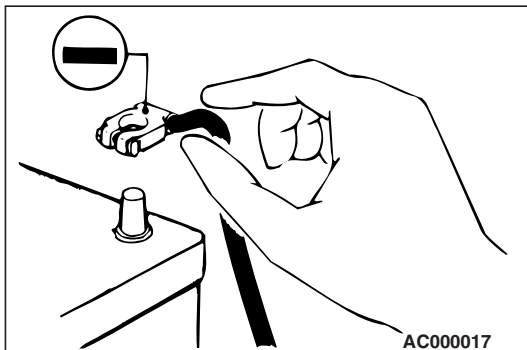

GENERAL ELECTRICAL SYSTEM CHECK

M1001005300045

A circuit consists of the power supply, switch, relay, load, ground, etc. There are various methods to check a circuit including an overall check, voltage check, short-circuit check, and continuity check. Each of the methods briefly described below applies only to circuits similar to the illustration.

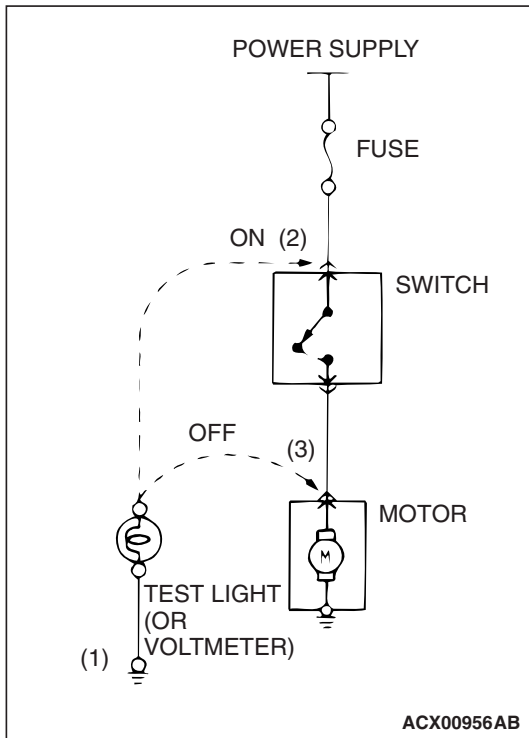

1. VOLTAGE CHECK

- (1) Ground one lead wire of the test light. If a voltmeter is used instead of the test light, ground the grounding side lead wire.
- (2) Connect the other lead wire of the test light to the power side terminal of the switch connector. The test light should come on or the voltmeter should indicate a voltage.
- (3) Then, connect the test light or voltmeter to the motor connector. The test light should not come on, or the voltmeter should indicate no voltage. When the switch is turned ON in this state, the test light should come on, or the voltmeter should indicate a voltage, with the motor starting to run.
- (4) The circuit illustrated here is normal. If there is any problem, such as the motor failing to run, check voltages beginning at the connector nearest to the motor until the faulty part is identified.

2. SHORT-CIRCUIT CHECK

Because the fuse has blown, it is probable that there is a short circuit. Follow the procedures below to narrow down the short-circuit location.

STEP 1. Remove the blown fuse and connect the test light across the fuse terminals (Circuit switch: OFF).

Q: Does the test light illuminate?

YES : Short-circuit exists between the fuse block and the switch. Repair the harness between the fuse block and the switch.

NO : Go to Step 2.

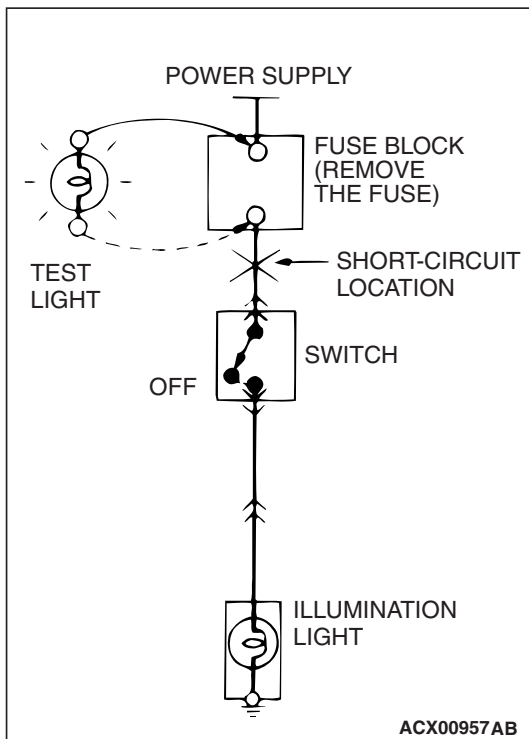

STEP 2. Turn the switch ON and disconnect the illumination light connector.

Q: Does the test light illuminate?

YES : Short-circuit exists between the switch and the connector. Repair the harness between the switch and the connector.

NO : Short-circuit exists between the connector and the illumination light. Repair the harness between the connector and the illumination light.

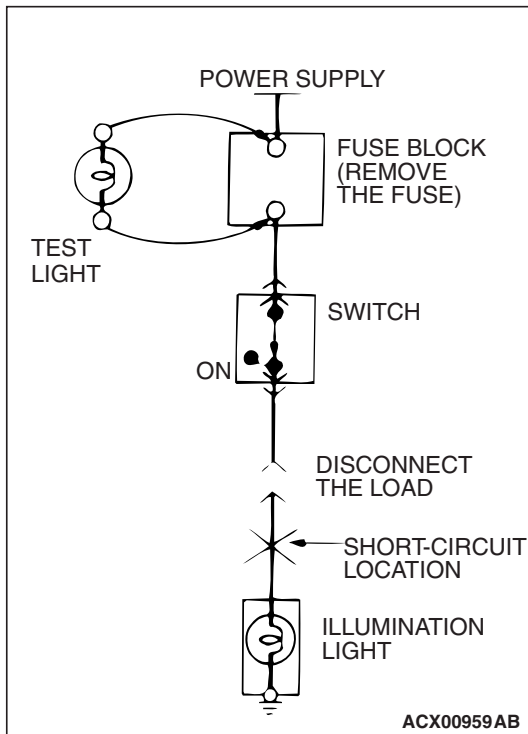
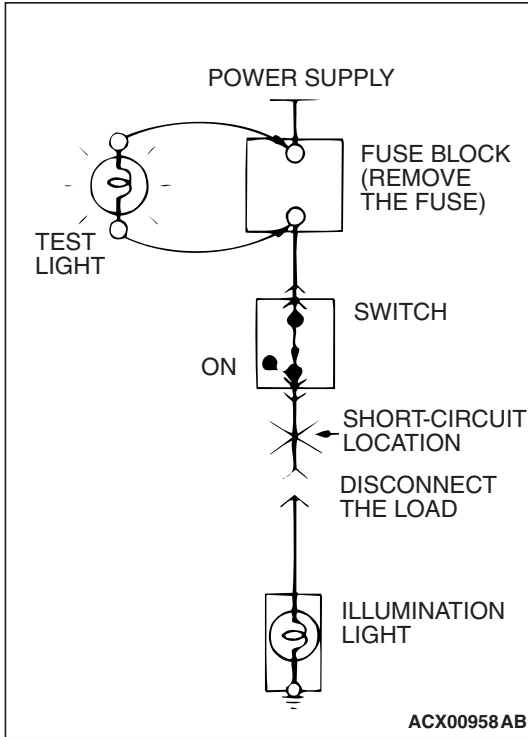

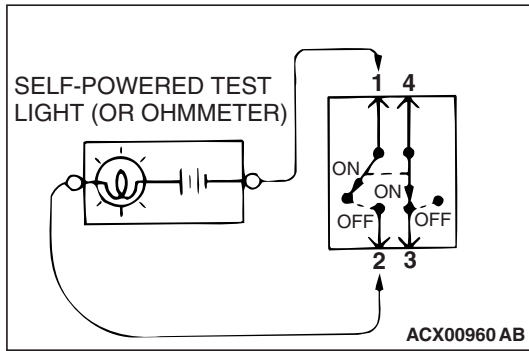

3. CONTINUITY CHECK

- (1) When the switch is in the "OFF" position and the contact points of terminals 1 and 2 are connected, the self-powered test light should illuminate or the ohmmeter should read 0 ohm.
- (2) When the switch is the "ON" position and the contact points of terminals 3 and 4 are connected, the self-powered test light should come on or the ohmmeter should read 0 ohm.

NOTES