

# GROUP 00

# GENERAL

## CONTENTS

<b>HOW TO USE THIS MANUAL . . . . .</b>	<b>00-3</b>	VEHICLE SAFETY CERTIFICATION LABEL . . . . .	00-20
<b>TROUBLESHOOTING GUIDELINES . . . . .</b>	<b>00-6</b>	NATIONAL SAFETY MARK <CANADA> . . . . .	00-20
<b>HOW TO USE TROUBLESHOOTING/INSPECTION SERVICE POINTS . . . . .</b>	<b>00-7</b>	THEFT PROTECTION LABEL . . . . .	00-21
TROUBLESHOOTING CONTENTS . . . . .	00-7	<b>PRECAUTIONS BEFORE SERVICE . . . . .</b>	<b>00-26</b>
HOW TO USE THE INSPECTION PROCEDURES . . . . .	00-10	CAUTIONS FOR WORKING IN ENGINE COMPARTMENT . . . . .	00-26
CONNECTOR MEASUREMENT SERVICE POINTS . . . . .	00-12	SUPPLEMENTAL RESTRAINT SYSTEM (SRS) . . . . .	00-26
CONNECTOR INSPECTION SERVICE POINTS . . . . .	00-14	HOW TO PERFORM VEHICLE IDENTIFICATION NUMBER (VIN) WRITING . . . . .	00-27
HOW TO COPE WITH INTERMITTENT MALFUNCTIONS . . . . .	00-15	INITIALIZATION PROCEDURE FOR LEARNING VALUE IN MFI ENGINE . . . . .	00-31
HOW TO TREAT PAST TROUBLE . . . . .	00-16	ENGINE IDLING LEARNING PROCEDURE . . . . .	00-32
INSPECTION SERVICE POINTS FOR A BLOWN FUSE . . . . .	00-17	TIMING CHAIN MAINTENANCE . . . . .	00-33
<b>VEHICLE IDENTIFICATION . . . . .</b>	<b>00-17</b>	SERVICING ELECTRICAL SYSTEM . . . . .	00-37
VEHICLE IDENTIFICATION NUMBER PLATE . . . . .	00-17	VEHICLE WASHING . . . . .	00-38
MODELS . . . . .	00-18	APPLICATION OF ANTI-CORROSION AGENTS AND UNDERCOATS . . . . .	00-38
CHASSIS NUMBER . . . . .	00-19	SCAN TOOL (MULTI USE TESTER { M.U.T.-III } SUB ASSEMBLY) . . . . .	00-39
ENGINE MODEL STAMPING . . . . .	00-19	CODING LIST . . . . .	00-39
VEHICLE IDENTIFICATION CODE PLATE . . . . .	00-19	BOLTS AND NUTS WITH STABILIZER FOR COEFFICIENT OF FRICTION . . . . .	00-47
TIRE AND LOADING INFORMATION PLACARD . . . . .	00-20	<b>TOWING AND HOISTING . . . . .</b>	<b>00-48</b>

Continued on next page

**GENERAL DATA AND SPECIFICATIONS . . . . . 00-52**

**TIGHTENING TORQUE . . . . . 00-54**

**LUBRICATION AND MAINTENANCE . . . . . 00-55**

**RECOMMENDED LUBRICANTS AND LUBRICANT CAPACITIES TABLE . . . . . 00-56**

**SCHEDULED MAINTENANCE TABLE . . . . . 00-59**

**MAINTENANCE SERVICE . . . . . 00-63**

1. FUEL SYSTEM (TANK, PIPE LINE AND CONNECTION, AND FUEL TANK FILLER TUBE CAP) (CHECK FOR LEAKS) . . . . . 00-63
2. FUEL HOSES (CHECK CONDITION) . . . . . 00-63
3. AIR CLEANER ELEMENT (REPLACE) . . . . . 00-63
4. EVAPORATIVE EMISSION CONTROL SYSTEM (EXCEPT EVAPORATIVE EMISSION CANISTER) (CHECK FOR LEAKS AND CLOGGING) . . . . . 00-63
5. SPARK PLUGS (REPLACE) . . . . . 00-64
6. INTAKE AND EXHAUST VALVE CLEARANCE (INSPECT AND ADJUST) . . . . . 00-64
7. DRIVE BELT (FOR THE GENERATOR AND POWER STEERING OIL PUMP) (REPLACE) . . . . . 00-66
8. EXHAUST SYSTEM (CONNECTIONS PORTION OF MUFFLER, MUFFLER PIPES AND CONVERTER HEAT SHIELDS) (CHECK AND SERVICE) . . . . . 00-67
9. ENGINE OIL (CHANGE) . . . . . 00-67

10. ENGINE OIL FILTER (REPLACE) . . . . . 00-68

11. MANUAL TRANSAXLE OIL (CHECK OIL LEVEL AND CONDITION/RCHANGE) . . . . . 00-68

12. TWIN CLUTCH SPORTRONIC SHIFT TRANSMISSION [CHECK OIL LEAKS (IF NECESSARY, CHECK THE OIL LEVEL) / CHANGE] . . . . . 00-70

13. TRANSFER OIL (CHECK OIL LEVEL/CHANGE) . . . . . 00-71

14. RESERVE TANK FLUID (FOR ACTIVE CENTER DIFFERENTIAL AND ACTIVE YAW CONTROL SYSTEM) (CHECK FLUID LEVEL) . . . . . 00-72

15. ENGINE COOLANT (CHANGE) . . . . . 00-73

16. COOLANT HOSES (RADIATOR HOSE, HEATER HOSE) (INSPECT) . . . . . 00-74

17. DISK BRAKE PADS AND ROTORS (INSPECT FOR WEAR) . . . . . 00-75

18. BRAKE HOSES (CHECK FOR DETERIORATION OR LEAKS) . . . . . 00-78

19. BALL JOINT AND STEERING LINKAGE SEALS (INSPECT FOR GREASE LEAKS AND DAMAGE) . . . . . 00-78

20. DRIVE SHAFT BOOTS (INSPECT FOR GREASE LEAKS AND DAMAGE) . . . . . 00-78

21. SUSPENSION SYSTEM (INSPECT FOR LOOSENESS AND DAMAGE) . . . . . 00-78

22. REAR AXLE OIL (FOR DIFFERENTIAL PART) (CHANGE) . . . . . 00-79

23. REAR AXLE OIL (FOR TORQUE TRANSFER MECHANISM PART) (CHANGE) . . . . . 00-79

24. TIRES (ROTATE) . . . . . 00-79

25. AIR PURIFIER FILTER (REPLACE) . . . . . 00-80

**MAIN SEALANT AND ADHESIVE TABLE . . . . . 00-80**

## HOW TO USE THIS MANUAL

M1001000102097

### MAINTENANCE, REPAIR AND SERVICING EXPLANATIONS

This manual provides explanations, etc. concerning procedures for the inspection, maintenance, repair and servicing of the subject model. Unless otherwise specified, each service procedure covers all models. Procedures covering specific models are identified by the model codes, or similar designation (engine type, transaxle type, etc.). A description of these designations is covered in this manual under "VEHICLE IDENTIFICATION."

### ON-VEHICLE SERVICE

The "ON-VEHICLE SERVICE" section has procedures for performing inspections and adjustments of particularly important components. These procedures are done with regard to maintenance and servicing, but other inspections (looseness, play, cracking, damage, etc.) must also be performed.

### SERVICE PROCEDURES

The service steps are arranged in numerical order. Attention to be paid in performing vehicle service are described in detail in SERVICE POINTS.

### DEFINITION OF TERMS

#### STANDARD VALUE

Indicates the value used as the standard for judging whether or not a part or adjustment is correct.

#### LIMIT

Shows the maximum or minimum value for judging whether or not a part or adjustment is acceptable.

#### REFERENCE VALUE

Indicates the adjustment value prior to starting the work (presented in order to facilitate assembly and adjustment procedures, and so they can be completed in a shorter time).

### DANGER, WARNING, AND CAUTION

DANGER, WARNING, and CAUTION call special attention to a necessary action or to an action that must be avoided. The differences among DANGER, WARNING, and CAUTION are as follows:

- If a DANGER is not followed, the result is severe bodily harm or even death.
- If a WARNING is not followed, the result could be bodily injury.
- If a CAUTION is not followed, the result could be damage to the vehicle, vehicle components or service equipment.

### TIGHTENING TORQUE INDICATION

The tightening torque indicates a median and its tolerance by a unit of N·m (in-lb) or N·m (ft-lb). For fasteners with no assigned torque value, refer to [P.00-54](#).

### SPECIAL TOOL NOTE

Only MMC special tool part numbers are called out in the repair sections of this manual. Please refer to the special tool cross-reference chart located at the beginning of each group, for the special tool number that is available in your market.

### ABBREVIATIONS

The following abbreviations are used in this manual for classification of model types:

2.0 L engine: 1.998 liter <4B11> engine, or a model equipped with such an engine.

A/C: Air conditioning.

AWD: Indicates 4-wheel-drive vehicles.

LIN: Local interconnect network

Keyless Operation System (KOS): Free-hand Advanced Security Transmitter (F.A.S.T.-key)

M/T: Indicates manual transaxle, or models equipped with manual transaxle.

MFI: Multiport fuel injection, or engines equipped with multiport fuel injection.

PCM: Powertrain control module

EXPLANATION OF MANUAL CONTENTS

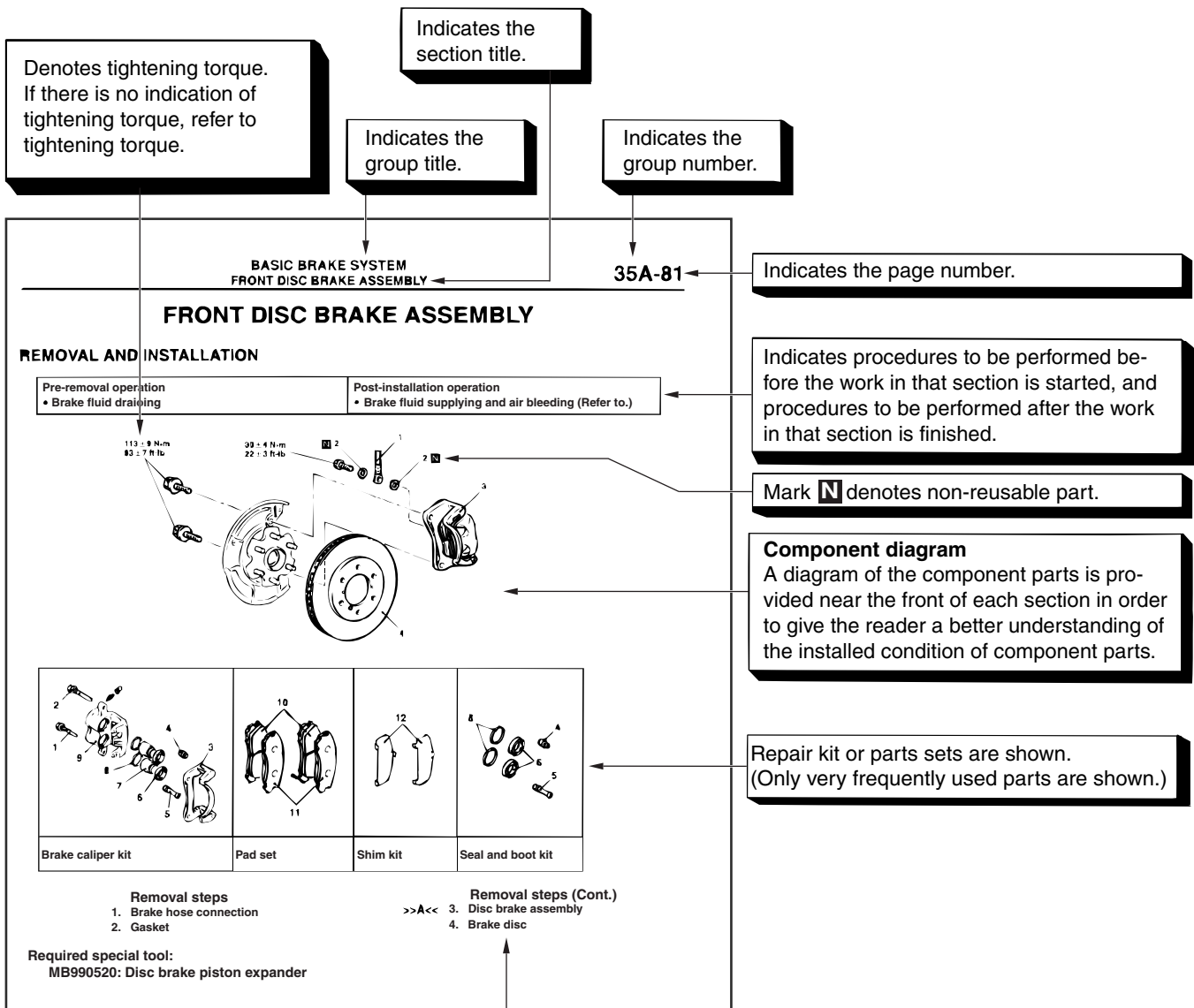

**Maintenance and servicing procedures**

The numbers provided within the diagram indicate the sequence for maintenance and servicing procedures.

- Removal steps :  
The part designation number corresponds to the number in the illustration to indicate removal steps.
- Disassembly steps :  
The part designation number corresponds to the number in the illustration to indicate disassembly steps.
- Installation steps :  
Specified in case installation is impossible in reverse order of removal steps. Omitted if installation is possible in reverse order of removal steps.
- Assembly steps :  
Specified in case installation is impossible in reverse order of removal steps. Omitted if assembly is possible in reverse order of disassembly steps.

**Classifications of major maintenance / service points**

When there are major points relative to maintenance and servicing procedures (such as essential maintenance and service points, maintenance and service standard values, information regarding the use of special tools, etc.). These are arranged together as major maintenance and service points and explained in detail.

<<A>> : Indicates that there are essential points for removal or disassembly.

>>A<< : Indicates that there are essential points for installation or assembly.

**Installation service point**

>>A<< **Disc brake assembly installation**

1. To check the brake drag force after mounting the pad, measure the hub torque in the advancing direction using a spring balance with the pad is removed.

**CAUTION**  
Do not allow any oil, grease or other contamination to contact the friction surfaces of the pads and brake discs.

2. After re-installing the caliper support to the knuckle, install the pad clips and the pads to the caliper support.

Operating procedures, cautions, etc. on removal, installation, disassembly and assembly are described

**LUBRICATION AND SEALING POINTS**

The title of the page (following the page on which the diagram of component parts is presented) indicating the locations of lubrication and sealing procedures.

Indicates (by symbols) where lubrication is necessary.

**Symbols for lubrication, sealants and adhesives**

Symbols are used to show the locations for lubrication and for application of sealants and adhesives. These symbols are included in the diagram of component parts or on the page following the component parts page. The symbols do not always have accompanying text to support that symbol.

- : Grease (Multi-purpose grease unless there is a brand or type specified)
- : Sealant or adhesive
- : Brake fluid or automatic transmission fluid
- : Engine oil, gear oil or air conditioning compressor oil
- : Adhesive tape or butyl rubber tape

# TROUBLESHOOTING GUIDELINES

M1001008800287

## VERIFY THE COMPLAINT

- Make sure the customer's complaint and the service writer's work order description are understood before starting work.
- Make sure the correct operation of the system is understood. Read the service manual description to verify normal system operation.
- Operate the system to see the symptoms. Look for other symptoms that were not reported by the customer, or on the work order, that may be related to the problem.

## DETERMINE POSSIBLE CAUSES

Compare the confirmed symptoms to the diagnostic symptom indexes to find the right diagnosis procedure.

If the confirmed symptoms cannot be found on any symptom index, determine other possible causes.

- Analyze the system diagrams and list all possible causes for the problem symptoms.
- Rank all these possible causes in order of probability, based on how much of the system they cover, how likely they are to be the cause, and how easy they will be to check. Be sure to take experience into account. Consider the causes of similar problems seen in the past. The list of causes should be ranked in order from general to specific, from most-likely to least-likely, and from easy-to-check to hard-to-check.

## FIND THE PROBLEM

After the symptoms have been confirmed, and probable causes have been identified, the next step is to make step-by-step checks of the suspected system components, junctions, and links in logical order.

Use the diagnostic procedures in the service manual whenever possible. Follow these procedures carefully to avoid missing an important step in the diagnosis sequence. It might be the skipped step that leads to the solution of the problem.

If the service manual doesn't have step-by-step procedures to help diagnose the problem, make a series of checks based on the ranked list of probable causes. Troubleshooting checks should be made in the order that the list of causes was ranked:

- general to specific
- most-likely to least-likely
- easy-to-check to hard-to-check

## REPAIR THE PROBLEM

When the step-by-step troubleshooting checks find a fault, perform the proper repairs. Make sure to fix the root cause of the problem, not just the symptom. Just fixing the symptom, without fixing the root cause, will cause the symptom to eventually return.

## VERIFY THE REPAIR

After repairs are made, recheck the operation of the system to confirm that the problem is eliminated. Be sure to check the system thoroughly. Sometimes new problems are revealed after repairs have been made.

## HOW TO USE TROUBLESHOOTING/ INSPECTION SERVICE POINTS

### TROUBLESHOOTING CONTENTS

**⚠ DANGER**

*The SRS-ECU adopts the rollover specification that the curtain air bag and seat belt pre-tensioner operate at the occurrence of rollover. Therefore, do not tilt the vehicle to the right and left with the IG ON or tilt the SRS-ECU to the right and left with the IG ON and the harness installed.*

**⚠ CAUTION**

During diagnosis, a diagnostic trouble code associated with other system may be set when the ignition switch is turned "ON" with connector(s) disconnected. On completion, confirm all systems for diagnostic trouble code(s). If diagnostic trouble code(s) are set, erase them all.

**⚠ WARNING**

*Since the radiator fan rotates during CAN bus line diagnostics, make sure that no one is servicing the engine compartment before diagnosing the CAN bus line. Since the CAN communication stops when diagnosing the CAN bus line, the ETACS-ECU detects the time-out of the engine control module, and activates the radiator fan to prevent overheating as fail-safe.*

### 1. STANDARD FLOW OF DIAGNOSTIC TROUBLESHOOTING

Troubleshooting sections are based on the diagnostic flow as below. If the diagnostic flow is different from that given below, or if additional explanation is required, the details of such differences or additions will also be listed.

M1001013300653

Troubleshooting of electronic control systems for which scan tool MB991958 can be used follows the basic outline described below. Even in systems for which scan tool MB991958 cannot be used, some of these systems still follow this outline.

## Diagnostic method

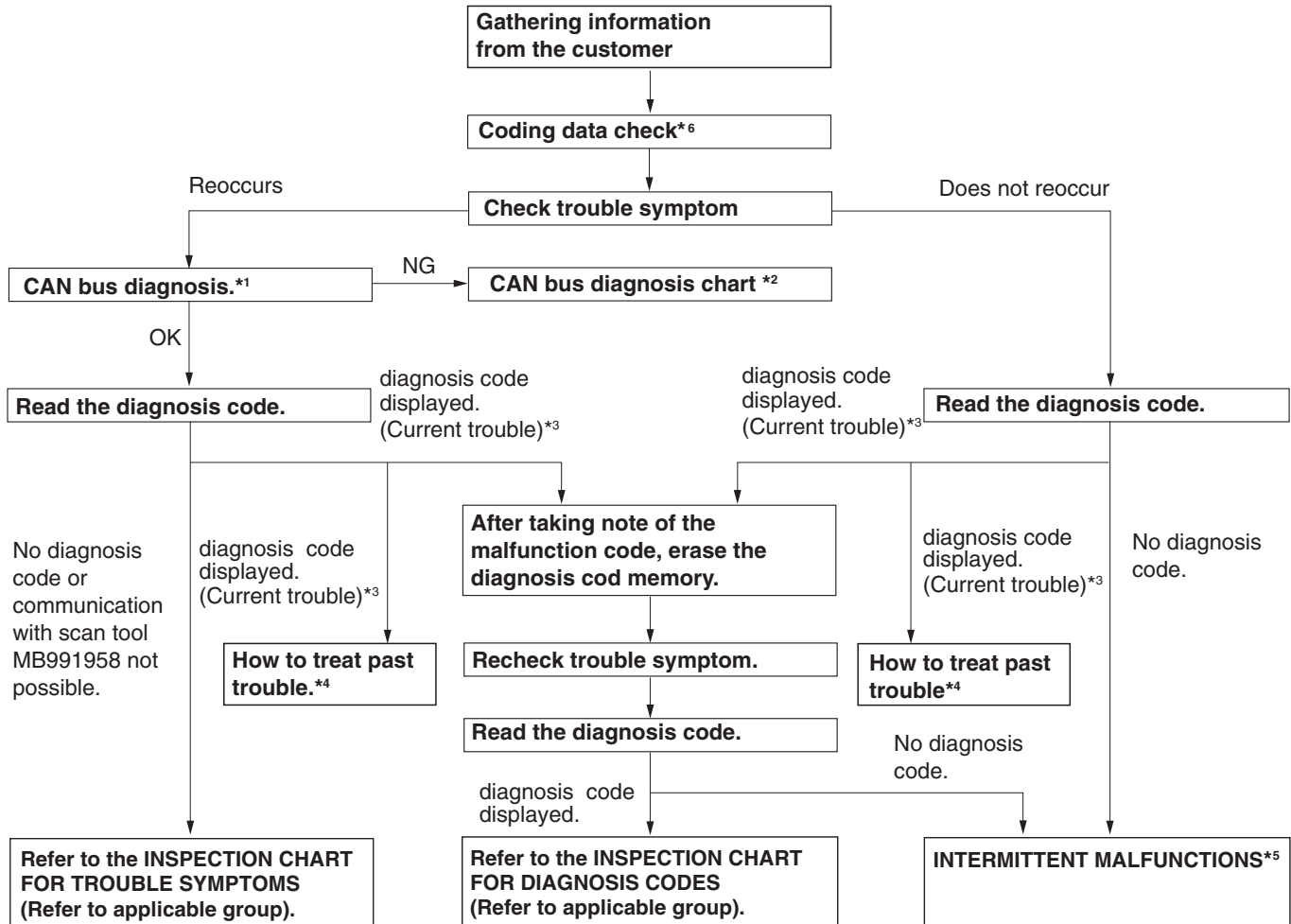

AC704160

- \*1: For how to diagnose CAN bus lines, refer to GROUP 54C P.54C-9.
- \*2: For the CAN bus diagnosis chart, refer to GROUP 54C P.54C-14.
- \*3: When scan tool MB991958 detects a diagnostic trouble code, its display informs users whether a mechanical problem currently exists or whether it existed before. The message for the former state identifies it as an "Active" and the message for the latter identifies it as a "Stored".
- \*4: For how to treat past trouble, refer to P.00-16.
- \*5: For how to cope with intermittent malfunctions, refer to P.00-15.
- \*6: For coding data, refer to P.00-39.

## 2. SYSTEM OPERATION AND SYMPTOM VERIFICATION TESTS

If verification of the symptom(s) is difficult, procedures for checking operation and verifying symptoms are shown.

## 3. DIAGNOSTIC FUNCTION

The following trouble code diagnosis are shown.

- How to read diagnostic trouble codes
- How to erase diagnostic trouble codes
- Input inspection service points

## 4. DIAGNOSTIC TROUBLE CODE CHART

If the scan tool displays a diagnostic trouble code, find the applicable inspection procedure according to this chart.

## 5. SYMPTOM CHART

If there are symptoms, even though the scan tools show that no DTCs are set, inspection procedures for each symptom will be found by using this chart.

## 6. DIAGNOSTIC TROUBLE CODE PROCEDURES

Indicates the inspection procedures corresponding to each diagnostic trouble code. (Refer to P.00-10).



## 7. SYMPTOM PROCEDURES

Indicates the inspection procedures corresponding to each symptom listed in the Symptom Chart. (Refer to P.00-10).

## 8. SERVICE DATA REFERENCE TABLE

Inspection items and normal judgment values have been provided in this chart as reference information.

## 9. CHECK AT ECU TERMINALS

Terminal numbers for the ECU connectors, inspection items, and standard values have been provided in this chart as reference information.

### TERMINAL VOLTAGE CHECKS

1. Connect a needle-nosed wire probe to a voltmeter probe.

**⚠ CAUTION**

**Short-circuiting the positive (+) probe between a connector terminal and ground could damage the vehicle wiring, the sensor, the ECU, or all three. Use care to prevent this!**

2. Insert the needle-nosed wire probe into each of the ECU connector terminals from the wire side, and measure the voltage while referring to the check chart.

*NOTE: Measure voltage with the ECU connectors connected.*

*You may find it convenient to pull out the ECU to make it easier to reach the connector terminals. Checks don't have to be carried out in the order given in the chart.*

3. If voltage readings differ from normal condition values, check related sensors, actuators, and wiring. Replace or repair as needed.

4. After repair or replacement, recheck with the voltmeter to confirm that the repair has corrected the problem.

### TERMINAL RESISTANCE AND CONTINUITY CHECKS

1. Turn the ignition switch to the "LOCK" (OFF) position.
2. Disconnect the ECU connector.

**⚠ CAUTION**

**If resistance and continuity checks are performed on the wrong terminals, damage to the vehicle wiring, sensors, ECU, and/or ohmmeter may occur. Use care to prevent this!**

3. Measure the resistance and check for continuity between the terminals of the ECU harness-side connector while referring to the check chart.  
*NOTE: Checks don't have to be carried out in the order given in the chart.*
4. If the ohmmeter shows any deviation from the Normal Condition value, check the corresponding sensor, actuator and related electrical wiring, then repair or replace.
5. After repair or replacement, recheck with the ohmmeter to confirm that the repair has corrected the problem.

### 10. INSPECTION PROCEDURES USING AN OSCILLOSCOPE

When there are inspection procedures using an oscilloscope, these are listed.

HOW TO USE THE INSPECTION PROCEDURES

The causes of many of the problems occurring in electric circuitry are generally the connectors, components, the ECU, and the harnesses between connectors, in that order. These inspection procedures follow this order. They first try to discover a problem with a connector or a defective component.

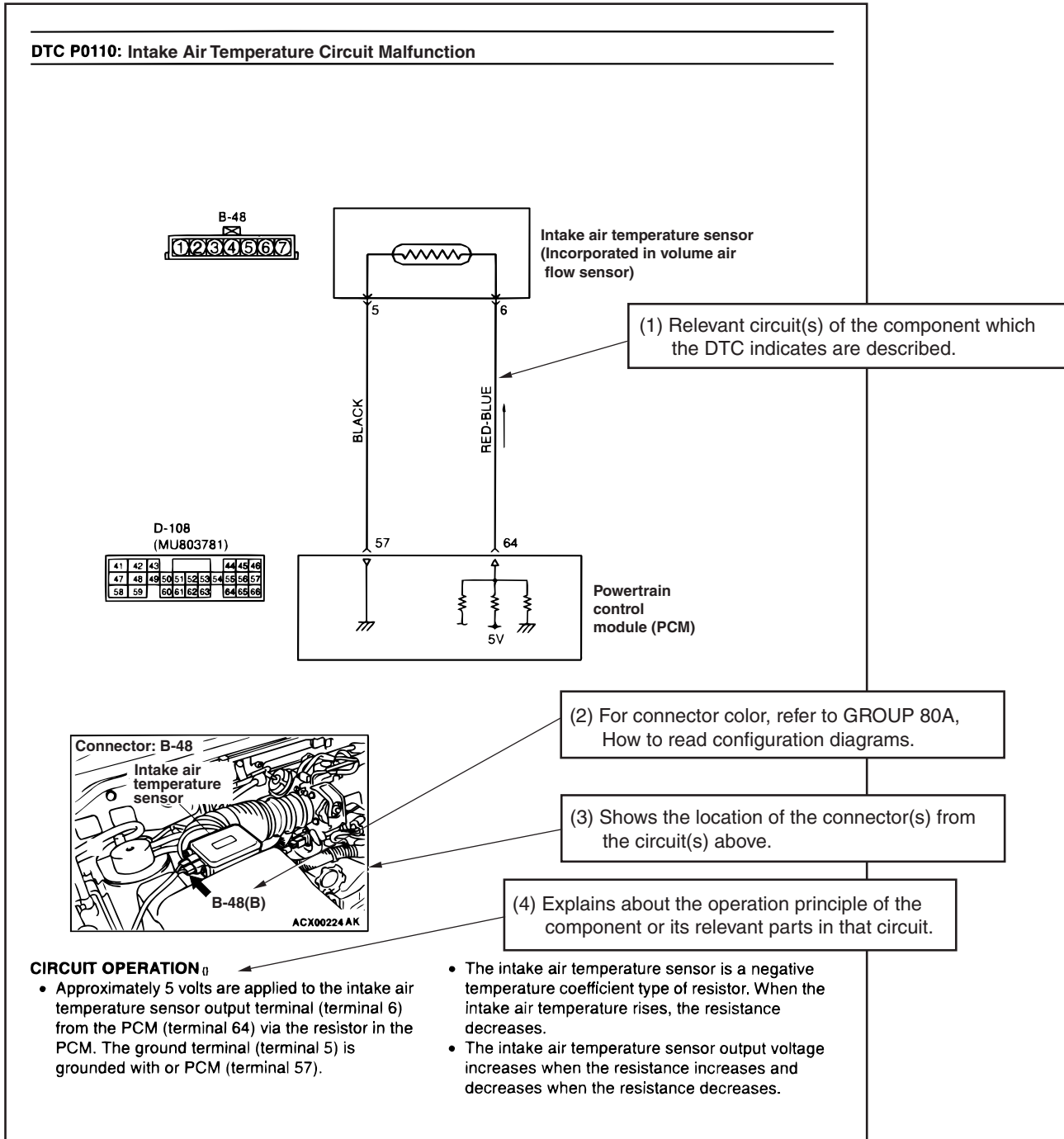

(5) Explains about technical details.

(6) Describes the conditions for that DTC being set (stored).

(7) Describes possible cause(s) for that DTC.

**TECHNICAL DESCRIPTION**

- The engine coolant temperature sensor converts the engine coolant temperature to a voltage and output it.

**DTC SET CONDITIONS**

**Check Conditions**

- Engine coolant temperature was 7°C (45°F) or more immediately before the engine was stopped at the last drive.

**TROUBLESHOOTING HINTS (The most likely causes for this code to be set are: )**

- Engine coolant temperature sensor failed.
- Open or shorted engine coolant temperature sensor circuit, or loose connector.
- PCM failed.

**DIAGNOSIS**

**Required special tool:**

- MB991958: Scan Tool (MUT-III Sub Assembly)
  - MB991824: V.C.I.
  - MB991827: USB Cable
  - MB991910: Main Harness A

**STEP 1. Using scan tool MB991958, check data list item 15: Transmission Fluid Temperature Sensor.**

**CAUTION**  
To prevent damage to scan tool MB991958, always turn the ignition switch to the "LOCK" (OFF) position before connecting or disconnecting scan tool MB991958.

- Connect scan tool MB991958 to the data link connector.
- Start the engine.
- Set scan tool MB991958 to the data reading mode for item 15, Transmission Fluid Temperature Sensor.
  - When the engine is cool: Almost equal to the ambient temperature (atmospheric temperature)
- Turn the ignition switch to the "LOCK" (OFF) position.

**NOTE:** Set scan tool MB991958 to data reading mode for item number 13, Intake Air Temperature (IAT) Sensor and note the temperature measurement. When the engine is cool, the temperature should be almost equal to the ambient temperature (atmospheric temperature), and the IAT sensor measurement should be approximately the same as the Transmission Fluid Temperature Sensor.

- When the engine is warm: 70 to 80°C (158 to 176°F)

**Q: Is the sensor operating properly?**

**YES :** It can be assumed that this malfunction is intermittent. Refer to GROUP 00, How to Use Troubleshooting/ Inspection Service Points – How to Cope with Intermittent Malfunction .

**NO :** Go to Step 2.

(8) Start of the diagnosis procedure for that DTC.

(9) Identifies the special tool(s) necessary for diagnosing that DTC.

(10) Provides the inspection procedure for that DTC step by step.

AC210616 AD

## HARNESS INSPECTION

Check for an open or short circuit in the harness between the terminals which were faulty according to the connector measurements. Carry out this inspection while referring to GROUP 00E, Harness Connector Inspection P.00E-2. Here, "Check harness between power supply and terminal xx" also includes checking for blown fuse. For inspection service points when there is a blown fuse, refer to "Inspection Service Points for a Blown Fuse P.00-17."

## MEASURES TO TAKE AFTER REPLACING THE ECU

If the trouble symptoms have not disappeared even after replacing the ECU, repeat the inspection procedure from the beginning.

**CONNECTOR MEASUREMENT SERVICE POINTS**

M1001013600610

Turn the ignition switch to the "LOCK" (OFF) position when connecting and disconnecting the connectors. Turn the ignition switch to "ON" when measuring, unless there are instructions to the contrary.

**IF INSPECTING WITH THE CONNECTOR CONNECTED <WATERPROOF CONNECTORS>**

Be sure to use special tool. Never insert a test probe from the harness side, as this will reduce the waterproof performance and result in corrosion.

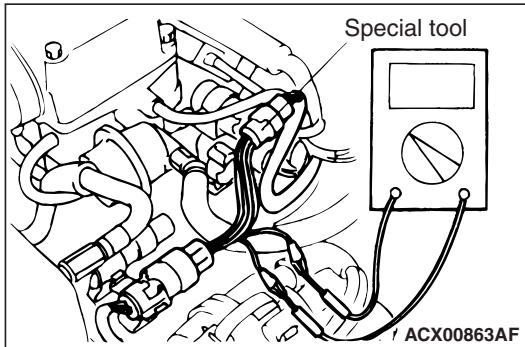
**IF INSPECTING WITH THE CONNECTOR CONNECTED <ORDINARY (NON-WATERPROOF) CONNECTORS>****Required Special Tool:**

- MB992006: Extra Fine Probe

Inspect by inserting a test probe from the harness side. If the connector is too small to insert a test probe (e.g. control unit connector), do not insert it forcibly. Use special tool MB992006 (extra fine probe).

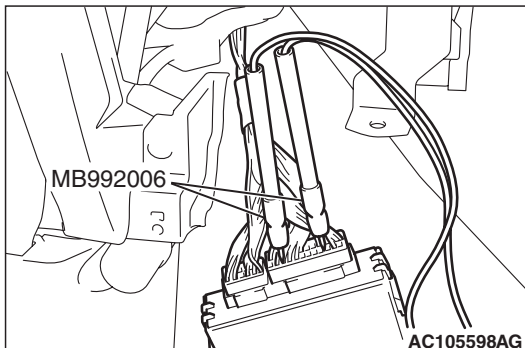
**IF INSPECTING WITH THE CONNECTOR DISCONNECTED****<When Inspecting a Female Pin>**

- From front side of the connector

**Required Special Tool:**

MB991219: Inspection Harness (Included in MB991223, Harness Set)

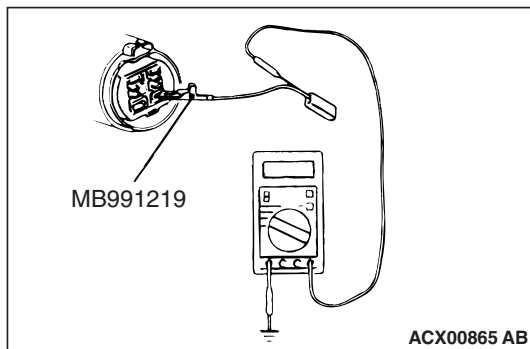

The inspection harness for connector pin contact pressure should be used. The test probe should never be forcibly inserted, as it may cause a defective contact.

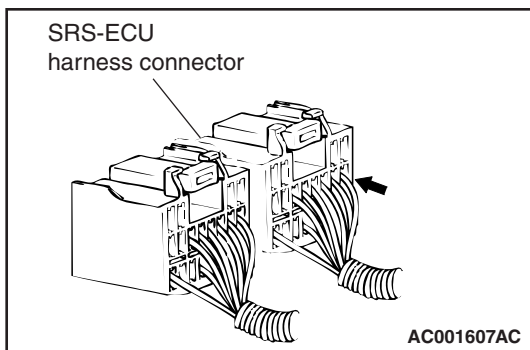

- From back side of the connector (SRS-ECU harness side connector)  
Since the SRS-ECU harness connector is plated to improve conductivity, observe the warning below when checking this connector.

**⚠ WARNING**

**Insert the backprobing tool into the connector from the harness side, and connect the tester to the backprobing tool. If any tool other than the backprobing tool is used, it may cause damage to the harness and other components. Furthermore, measurement should not be carried out by touching the backprobing tool directly against the terminals from the front of the connector. The terminals are plated to increase their conductivity, so that if they are touched directly by the backprobing tool, the plating may break, which will decrease reliability.**

<When Inspecting a Male Pin>

**⚠ CAUTION**

**At this time, be careful not to short the connector pins with the test probes. Doing so may damage the circuits inside the ECU.**

Touch the pin directly with the test probe.

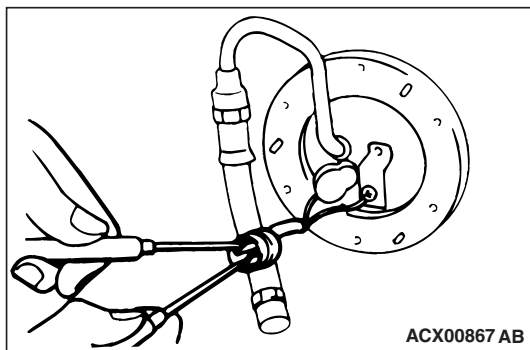

**CONNECTOR INSPECTION SERVICE POINTS**

M1001013700424

**VISUAL INSPECTION**

- Connector is disconnected or improperly connected
- Connector pins are pulled out
- Stretched or broken wires at terminal section
- Low contact pressure between male and female terminals
- Low connection pressure due to rusted terminals or foreign matter lodged in terminals

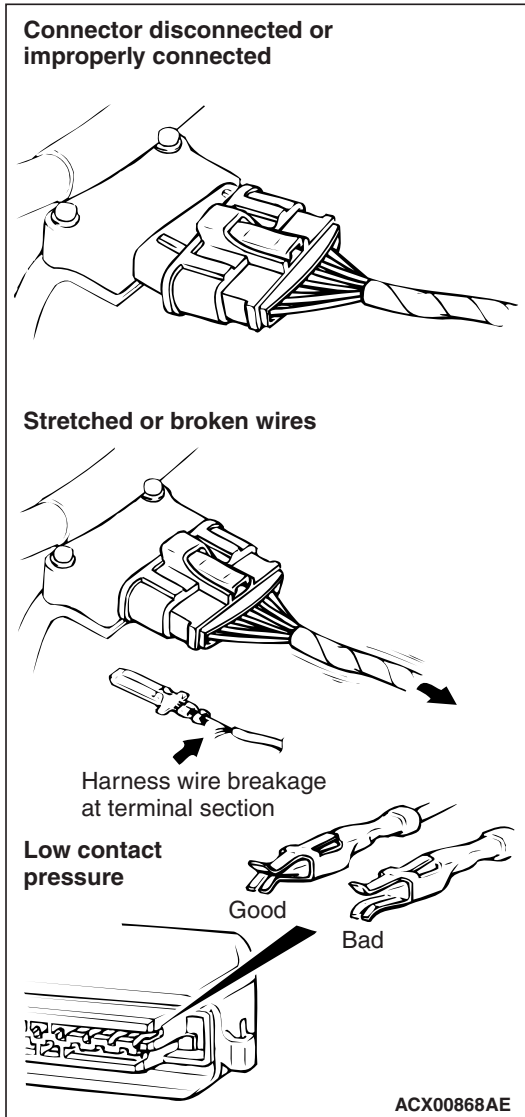
**CONNECTOR PIN INSPECTION**

If the connector pin stopper is damaged, the terminal connections (male and female pins) will not be perfect even when the connector body is connected, because the pins may pull out of the back side of the connector. Therefore, gently pull the wires one by one to make sure that no pins pull out of the connector.

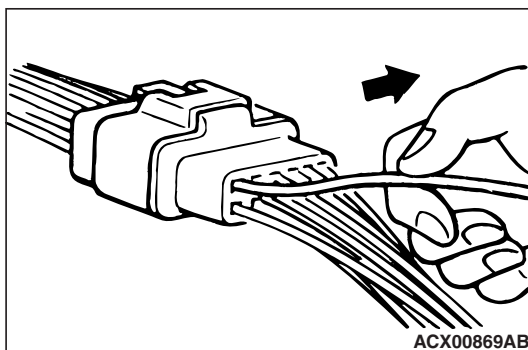

## CONNECTOR ENGAGEMENT INSPECTION

### Required Special Tool:

MB991219: Inspection Harness (contained in MB991223 Test Harness)

Use special tool, MB991219 to inspect the engagement of the male pins and female pins. [Pin drawing force: 1 N (0.2 pound) or more]

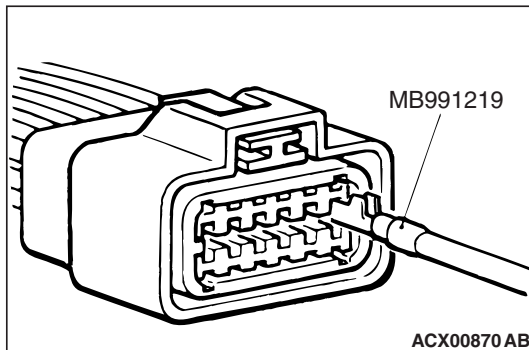

## HOW TO COPE WITH INTERMITTENT MALFUNCTIONS

M1001013900451

Most intermittent malfunctions occur under certain conditions. If those conditions can be identified, the cause will be easier to find.

### TO COPE WITH INTERMITTENT MALFUNCTION; 1. ASK THE CUSTOMER ABOUT THE MALFUNCTION

Ask what it feels like, what it sounds like, etc. Then ask about driving conditions, weather, frequency of occurrence, and so on.

### 2. DETERMINE THE CONDITIONS FROM THE CUSTOMER'S RESPONSES

Typically, almost all intermittent malfunctions occur from conditions like vibration, temperature and/or moisture change, poor connections. From the customer's responses, it should be reasoned which condition is most likely.

### 3. USE SIMULATION TEST

Use the simulation tests below to attempt to duplicate the customer's complaint. Determine the most likely circuit(s) and perform the simulation tests on the connectors and parts of that circuit(s). Be sure to use the inspection procedures provided for diagnostic trouble codes and trouble symptoms.

For temperature and/or moisture condition related intermittent malfunctions, try to change the conditions of the suspected circuit components, then use the simulation tests below.

#### 4. VERIFY THE INTERMITTENT MALFUNCTION IS ELIMINATED

Repair the malfunctioning part and try to duplicate the condition(s) again to verify the intermittent malfunction has been eliminated.

#### SIMULATION TESTS

*NOTE: In case of difficulty in finding the cause of the intermittent malfunction, the data recorder function in the scan tool is effective.*

For these simulation tests, shake, then gently bend, pull, and twist the wiring of each of these examples to duplicate the intermittent malfunction.

- Shake the connector up-and-down, and right-and-left.
- Shake the wiring harness up-and-down, and right-and-left. Especially, check the splice points of wiring harnesses carefully. Refer to GROUP 00E, Harness Connector Inspection [P.00E-2](#).
- Shake the part or sensor.

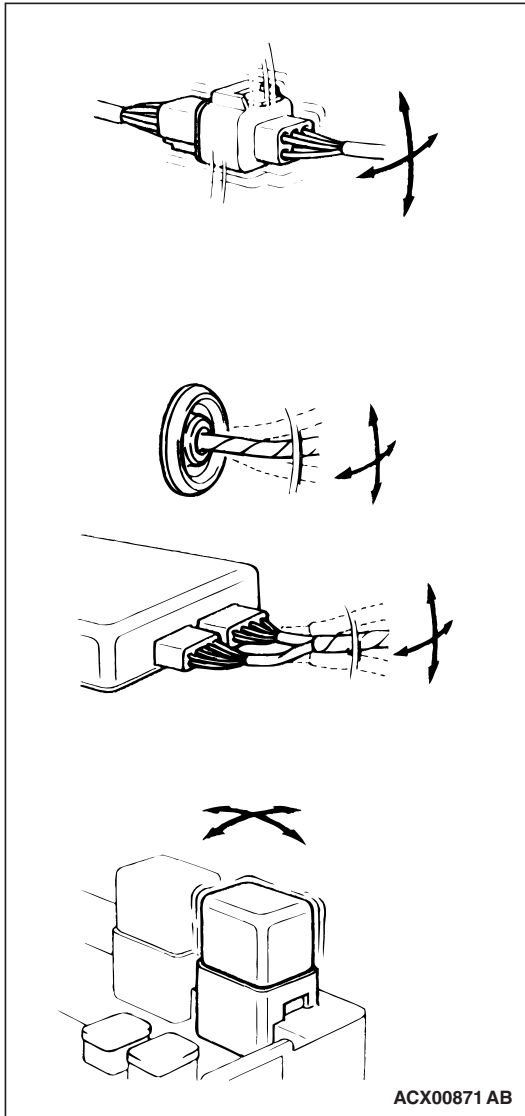

#### HOW TO TREAT PAST TROUBLE

Since the trouble may still be present even the status is "Stored", set the vehicle to the diagnostic trouble code detection condition and check that the status changes to "Active". If the status does not change from "Stored", carry out the following procedure.

1. Establish from the customer whether a fuse or connector has been replaced or disconnected.

- M1001014100384
2. If yes, erase the diagnostic trouble code, and then check that no diagnostic code is reset. If no diagnostic trouble code is reset, the diagnosis is complete.
  3. If no, follow the applicable Diagnostic Trouble Code Chart. Then check the wiring harness and connector, and refer to "How to Cope with Intermittent Malfunction [P.00-15](#)."



## INSPECTION SERVICE POINTS FOR A BLOWN FUSE

M1001013800409

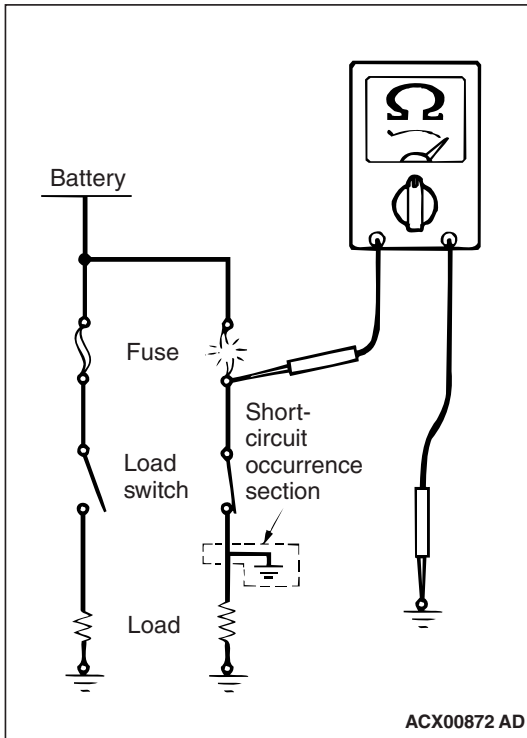

Remove the blown fuse and measure the resistance between the load side of the blown fuse and the ground. Close the switches of all circuits which are connected to this fuse. If the resistance is almost  $0 \Omega$  at this time, there is a short somewhere between these switches and the load. If the resistance is not  $0 \Omega$ , there is no short at the present time, but a momentary short has probably caused the fuse to blow.

The main causes of a short circuit are the following.

- Harness being clamped by the vehicle body
- Damage to the outer casing of the harness due to wear or heat
- Water getting into the connector or circuitry
- Human error (mistakenly shorting a circuit, etc.)

## VEHICLE IDENTIFICATION

### VEHICLE IDENTIFICATION NUMBER PLATE

M1001005500243

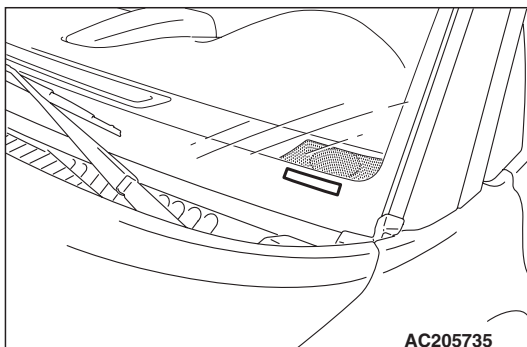

The vehicle identification number (VIN) plate is located on a plate attached to the left top side of the instrument panel.

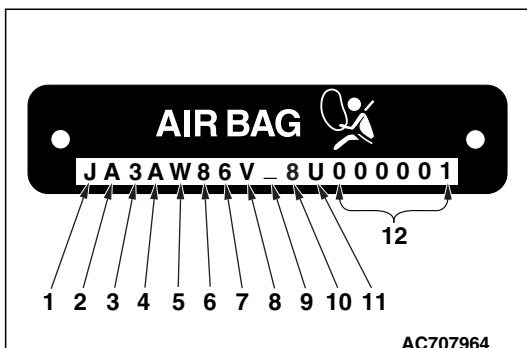

### CODE CHART

No.	Item	Content	
1	Country	J	JAPAN
2	Make	A	Mitsubishi Motors
3	Vehicle type	3	Passenger car
4	Others	A	Driver and passenger air bags
5	Line	W	LANCER EVOLUTION
6	Trim level (Price class)	5	PREMIUM
		8	SPORTS

No.	Item	Content	
7	Body style	6	4-door sedan
8	Engine type	V	2.0L DOHC MIVEC with charge air cooler, turbocharger (4B11)
9	Check digits*	0, 1, 2, 3, -----9, X	
10	Model year	8	2008 year
11	Plant	U	Mizushima
12	Serial number	000001 to 999999	

NOTE: \*: Check digit means a single number, or letter X, used to verify the accuracy of transcription of vehicle identification number.

## MODELS

M1001000302444

## VEHICLE IDENTIFICATION NUMBER LIST

### VEHICLES FOR USA

Model code		VIN code (Except sequence number)	Engine model	Transaxle model	Fuel supply system
CZ4A	SNGFZL2M	JA3AW86V_8U	4B11 DOHC MIVEC with Charge air cooler, Turbocharger [1 998 cm <sup>3</sup> (121.9 cu in) ] petrol engine	W5M6A (AWD, 5M/T)	MFI
	SMGFZL2M	JA3AW86V_8U		W6DGA [AWD, Twin Clutch Sportronic Shift Transmission (TC-SST)]	
	SMPFZL2M	JA3AW86V_5U			

### VEHICLES FOR CANADA

Model code		VIN code (Except sequence number)	Engine model	Transaxle model	Fuel supply system
CZ4A	SNGFZL3M	JA3AW86V_8U	4B11 DOHC MIVEC with Charge air cooler, Turbocharger [1 998 cm <sup>3</sup> (121.9 cu in) ] petrol engine	W5M6A (AWD, 5M/T)	MFI
	SMPFZL3M	JA3AW86V_5U		W6DGA [AWD, Twin Clutch Sportronic Shift Transmission (TC-SST)]	

**CHASSIS NUMBER**

M1001005600369

The chassis number is stamped on the front floor pan.

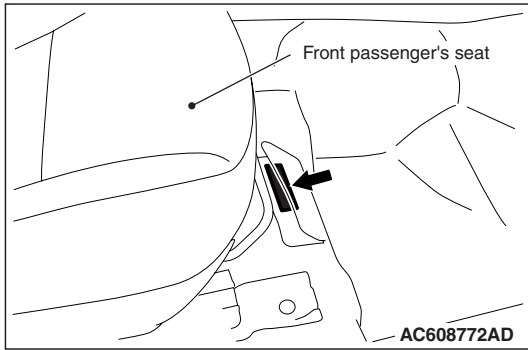

**CODE CHART**

Chassis number code	Content	
CZ4A8U00001	Vehicle line	CZ4A; LANCER EVOLUTION
	8U000001; Refer to 10th thru 17th digits of VIN plate	

**ENGINE MODEL STAMPING**

M1001005700322

The engine model is stamped on the cylinder block.  
The engine model number is as shown as follow.

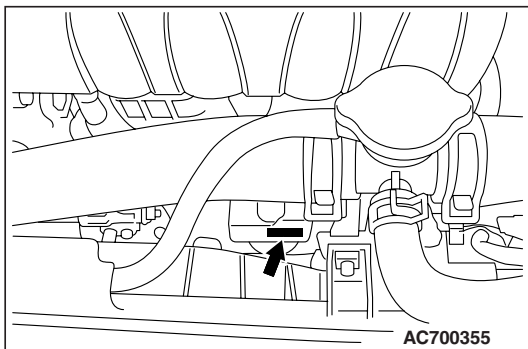

Engine model	Engine displacement
4B11	2.0L

The engine serial number is stamped near the engine model number.

Engine number	AA0201 to YY9999
---------------	------------------

**VEHICLE IDENTIFICATION CODE PLATE**

M1001005400116

The information code plate is riveted onto the cowl top outer panel in the engine compartment.

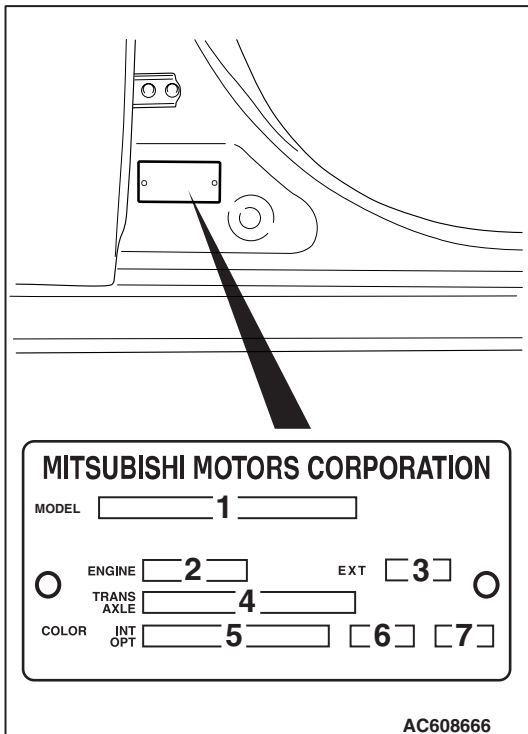

**CODE CHART**

No.	Item	Example	Content
1	MODEL	CZ4AS	Vehicle model
		MGFZL2M	Model series
2	ENGINE	4B11	Engine model
3	EXT	W69C	Exterior code
4	TRANS AXLE	W4A5A	Transaxle model
5	COLOR	W69	Body color code
6	TRIM	06E	Interior code
7	OPT	Q40	Equipment code

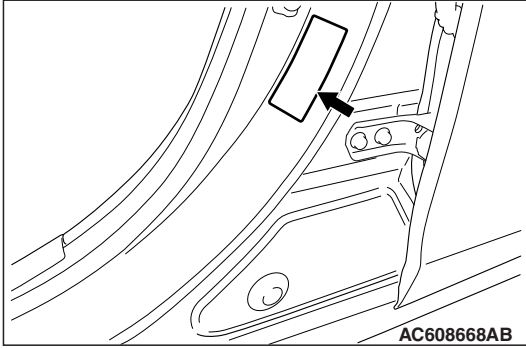
**TIRE AND LOADING INFORMATION PLACARD**

M1001015800137

The tire and loading information placard is located on the inside sill of the driver's door.

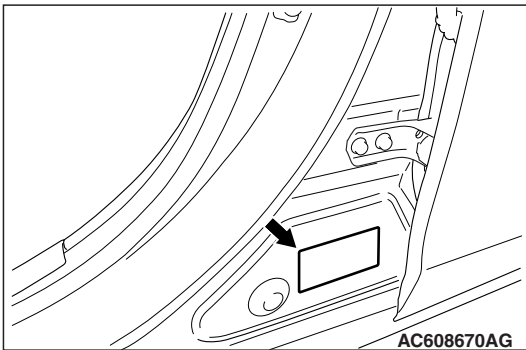
**VEHICLE SAFETY CERTIFICATION LABEL**

M1001017300020

The vehicle safety certification label is attached to the face of the left door sill.

This label indicates the month and year of manufacture, Gross Vehicle Weight Rating (GVWR), front and rear Gross Axle Weight Rating (GAWR), and Vehicle Identification Number (VIN).

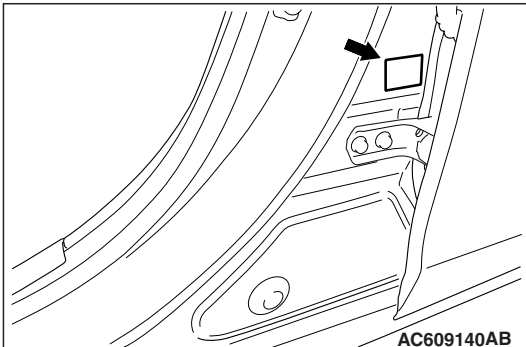
**NATIONAL SAFETY MARK <CANADA>**

M1001017400016

The tire and loading information placard is located on the inside sill of the driver's door.

**THEFT PROTECTION LABEL**

M1001015700260

**⚠ CAUTION**

When replacing a part that has the theft protection plate, label or stamp on it, be sure that the part has either **A** or **B** shown in the figure. It is illegal if both **A** and **B** are attached, or neither **A** nor **B** is attached.

In order to protect against theft, a Vehicle Identification Number (VIN) is attached as a plate or label to the following major parts of the engine, transaxle and main outer panels: Engine cylinder block, Transaxle housing, Front fender, Hood, Trunk lid, Bumpers, Side outer panel, Doors. In addition, a theft-protection label is attached to replacement parts for main outer panels. The same data is stamped into replacement parts for the engine and the transaxle.



**⚠ CAUTION**

**Cautions regarding panel repairs:**

- When repainting original parts, do so after first masking the theft-protection label. After painting, be sure to peel off the masking tape.
- The theft-protection label for replacement parts is covered by masking tape, so such parts can be painted as is. The masking tape should be removed after painting is finished.
- The theft-protection label should not be removed from original parts or replacement parts.

**Theft protection plate and label**

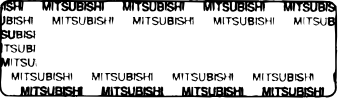
For original parts





For replacement parts

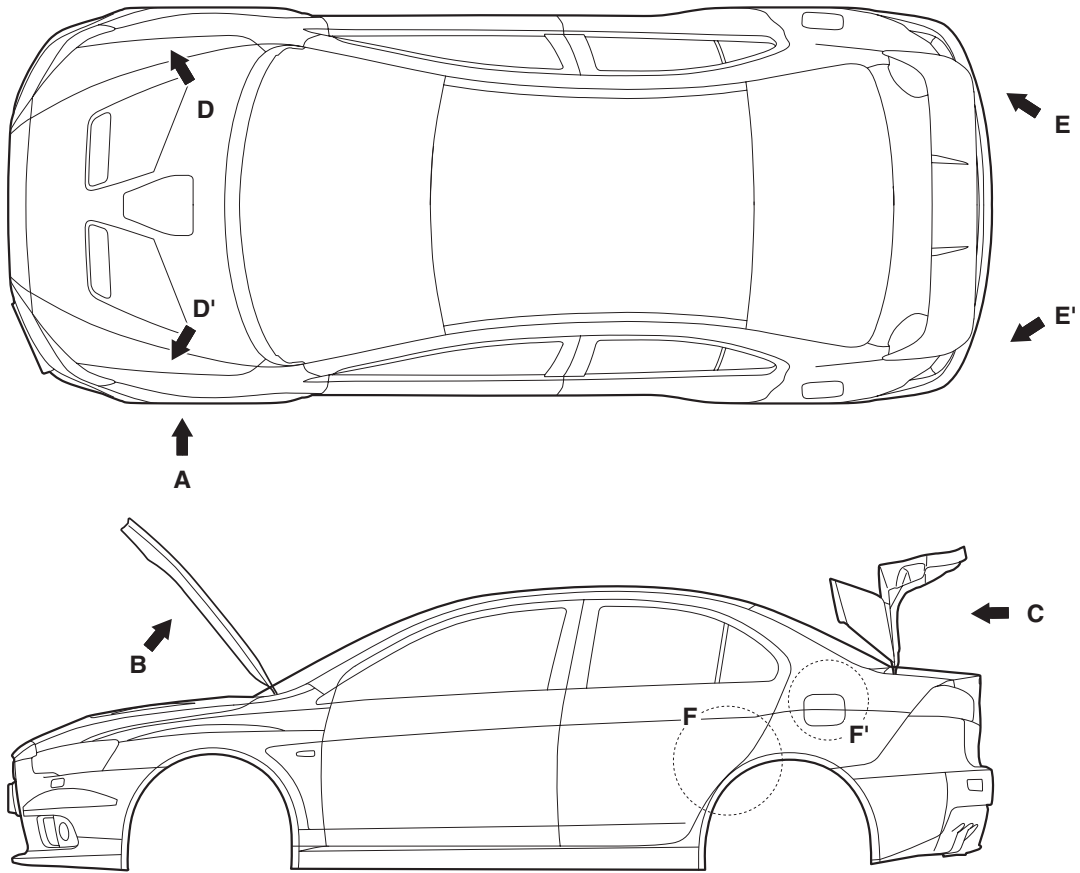

AC704152AB

LOCATIONS



AC710510AC

Label area (x: for original equipment parts, y: for replacement parts)

Engine

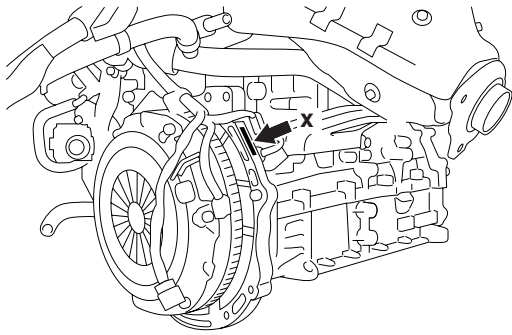

AC609841AB

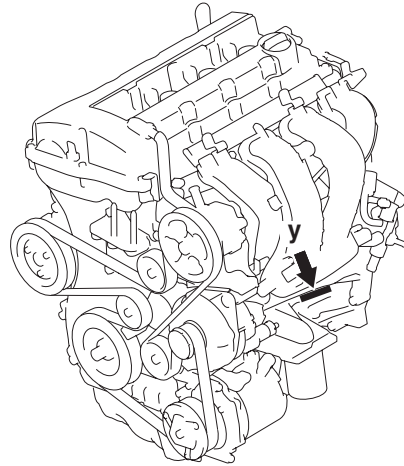

AC612304AB

Manual transaxle (M/T)

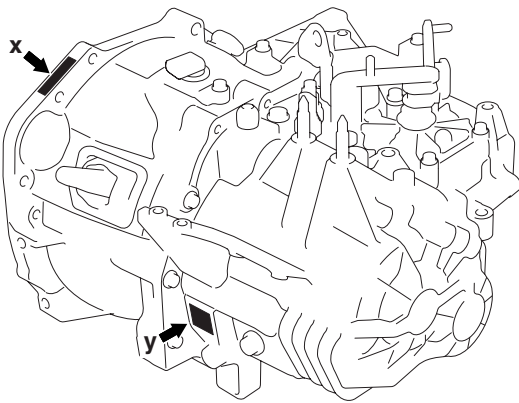

AC708134AB

Twin clutch sportronic shift transmission (TC-SST)

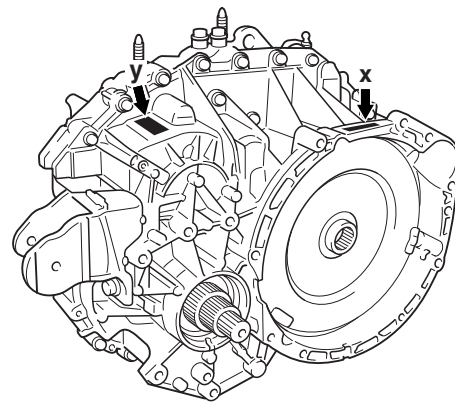

AC707965AB

View A (Front fender)

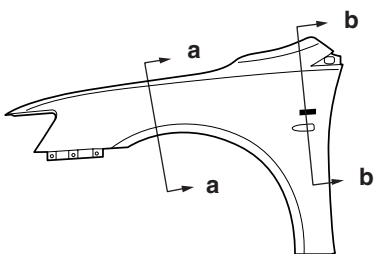

Section a - a

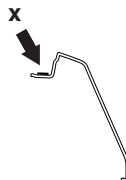

Section b - b

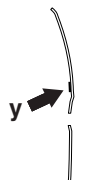

The illustration indicates left outer side.  
Right side is symmetrically opposite.

AC608723AB

View B (Hood)

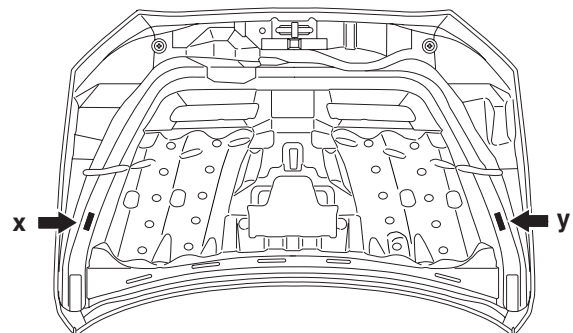

AC708456AB

Label area (x: for original equipment parts, y: for replacement parts)

View C (Trunk lid)

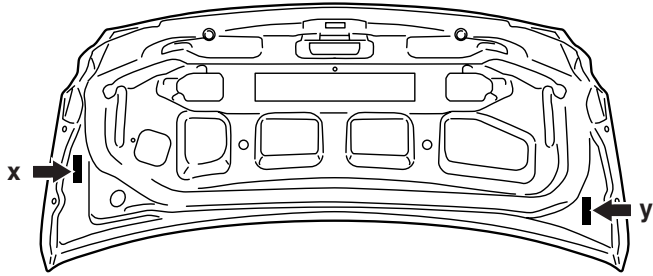

AC612302AB

View D (Front bumper)

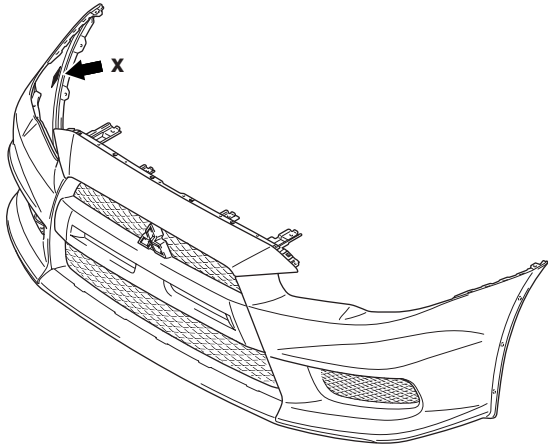

AC710511AB

View D'

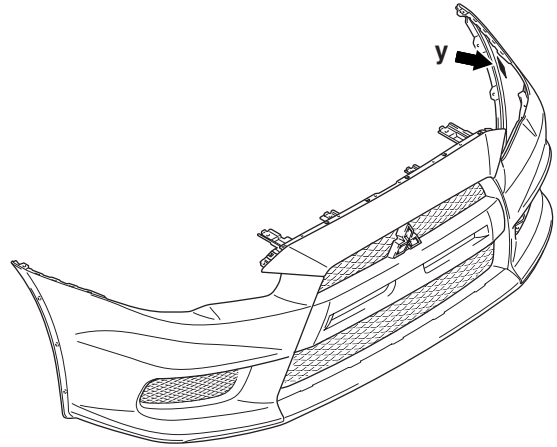

AC710513



Label area (x: for original equipment parts, y: for replacement parts)

View E (Rear bumper)

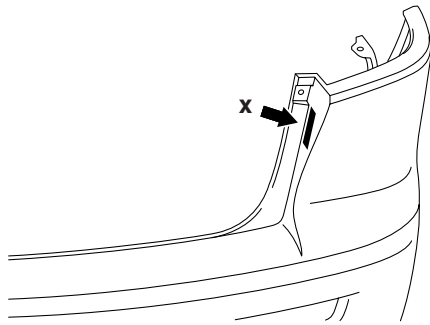

AC608729AB

View E'

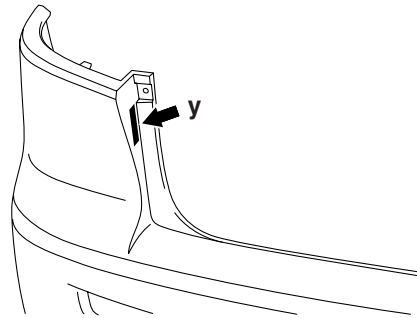

AC608730AB

View F (Side outer panel)

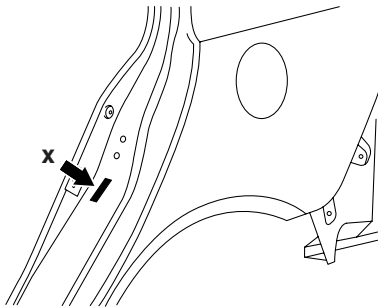

The illustration indicates left outer side.  
Right side is symmetrically opposite.

AC608733AB

View F'

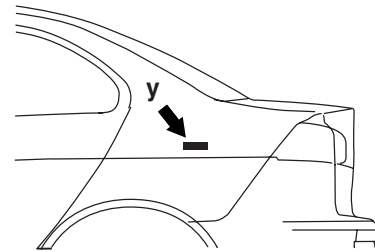

The illustration indicates left outer side.  
Right side is symmetrically opposite.

AC611136AB

Front door (both side)

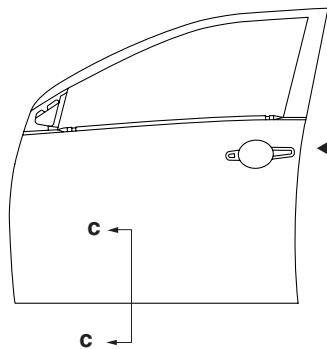

The illustration indicates left outer side.  
Right side is symmetrically opposite.

View G

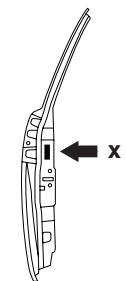

Section c - c

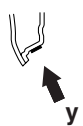

AC608731AC

Rear door (both side)

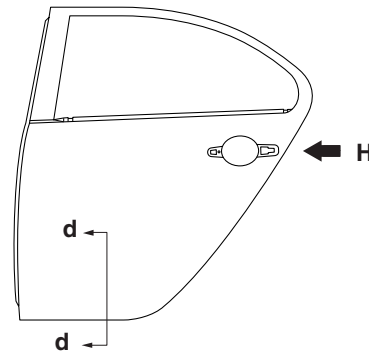

The illustration indicates left outer side.  
Right side is symmetrically opposite.

View H

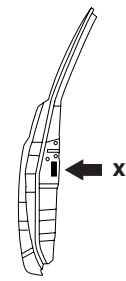

Section d - d



AC608734AC

# PRECAUTIONS BEFORE SERVICE

## CAUTIONS FOR WORKING IN ENGINE COMPARTMENT

M1001016800022

**⚠ WARNING**

***Just after the ignition switch is turned to "LOCK" (OFF) position, the adjustments must always be made with the cooling fan stopped. After the ignition switch is turned to "LOCK" (OFF) position, the cooling fan might be driven for a few minutes by the after run fan control. If the adjustments are made with the cooling fan driven, injury or damage may occur.***

## SUPPLEMENTAL RESTRAINT SYSTEM (SRS)

M1001011600636

1. Items to review when servicing SRS:
  - (1) Be sure to read GROUP 52B, Supplemental Restraint System (SRS). For safe operation, please follow the directions and heed all warnings.
  - (2) Wait at least 60 seconds after disconnecting the battery cable before doing any further work. The SRS system is designed to retain enough voltage to deploy the air bag even after the battery has been disconnected. Serious injury may result from unintended air bag deployment if work is done on the SRS system immediately after the battery cable is disconnected.
  - (3) Warning labels must be heeded when servicing or handling SRS components. Warning labels can be found in the following locations.
    - Air bag module (Driver's or front passenger's)
    - Clock spring
    - SRS-ECU
    - Knee air bag module
    - Sun visor
    - Seat belt pre-tensioner
    - Side-airbag module (Driver's side and front passenger's side)
    - Curtain air bag module (Driver's side and front passenger's side)
    - Center pillar (Driver's side and front passenger's side)
    - Glove box
  - (4) Always use the designated special tools and test equipment.
  - (5) Store components removed from the SRS in a clean and dry place. The air bag module should be stored on a flat surface and placed so that the pad surface is facing upward.
  - (6) Never attempt to disassemble or repair the SRS components (SRS-ECU, air bag module and clock spring). If there is a defect, replace the defective part.
  - (7) Whenever you finish servicing the SRS, check the SRS warning light operation to make sure that the system functions properly.
  - (8) Be sure to deploy the air bag before disposing of the air bag module or disposing of a vehicle equipped with an air bag (Refer to GROUP 52B [P.52B-417](#), Air Bag Module Disposal Procedures).
2. Observe the following when carrying out operations on places where SRS components are installed, including operations not directly related to the SRS air bag.
  - (1) When removing or installing parts, do not allow any impact or shock to occur to the SRS components.
  - (2) If heat damage may occur during paint work, remove the SRS-ECU, the air bag module, clock spring, the front impact sensor, the side impact sensor, and the seat belt pre-tensioner.
  - SRS-ECU, air bag module, clock spring, front impact sensor, the side impact sensor: 93 °C (200 °F) or more
  - Seat belt pre-tensioner: 90 °C (194 °F) or more

## HOW TO PERFORM VEHICLE IDENTIFICATION NUMBER (VIN) WRITING

### **CAUTION**

The F.A.S.T-Key (Free-hand Advanced Security Transmitter) is described as the Keyless Operation System (KOS) in this manual. (KOS is indicated as F.A.S.T. in the scan tool display.)

Follow the procedure below to register the VIN of the Wireless Control Module (WCM) and the Keyless Operation System (KOS).

The VIN is stored in the engine control module (ECM), WCM, and the KOS-ECU. If the VIN is improperly erased, the engine warning light or the keyless operation system warning indicator illuminate, and the diagnostic trouble code is displayed. When the ECM, WCM, and the KOS-ECU are replaced, follow the procedure below to write the VIN.

### Screen flow of scan tool (M.U.T.- III)

<When ECM is replaced>

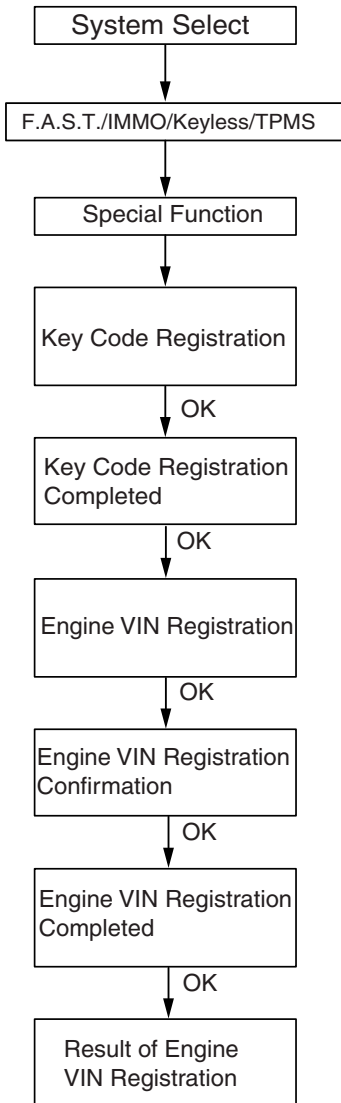

<When WCM or KOS-ECU are replaced>

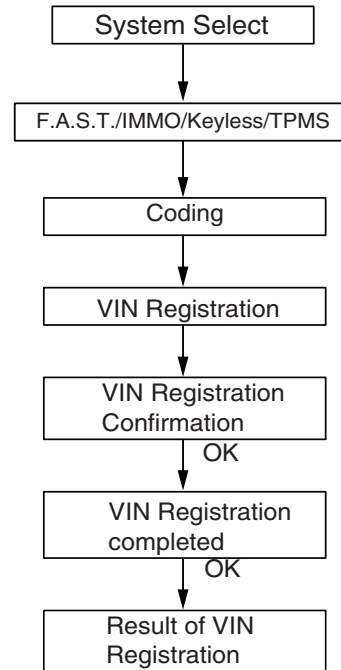

## WRITING PROCEDURE

## Required Special Tools:

- MB991958: Scan Tool (M.U.T.-III Sub Assembly)
  - MB991824: V.C.I.
  - MB991827: M.U.T.-III USB Cable
  - MB991910: M.U.T.-III Main Harness A

**⚠ CAUTION**

Check that diagnostic trouble code P0603 "EEPROM fail" is not set. When diagnostic trouble code P0603 "EEPROM fail" is set, the ECM cannot store the key code even if the key code is registered. If this diagnostic trouble code is set, troubleshoot the ECM and repair. Then register the key code to the ECM.

**⚠ CAUTION**

Before connecting or disconnecting the MB991958: Scan Tool, turn the ignition switch to the "LOCK" (OFF) position. Connect scan tool MB991958 to the 16-pin data link connector as follows.

*NOTE: For details on how to use scan tool MB991958, refer to the "M.U.T.-III Owner's Manual."*

1. Ensure that the ignition switch is at the "LOCK" (OFF) position.
2. Start up the personal computer.
3. Connect special tool MB991827 to special tool MB991824 and the personal computer.
4. Connect special tool MB991910 to the special tool MB991824.
5. Connect special tool MB991910 to the data link connector of the vehicle.
6. Turn the special tool MB991824 power switch to the "ON" position.

*NOTE: When the special tool MB991824 is energized, the special tool MB991824 indicator light will be illuminated in a green color.*

7. Start the "M.U.T.-III system" on the personal computer and turn the ignition switch to the "ON" position.
8. Select "F.A.S.T./IMMO/Keyless/TPMS" button from the "System Select" screen. Then, select the applicable option code item and push the OK button.
9. Select "Special Function" on the next screen.

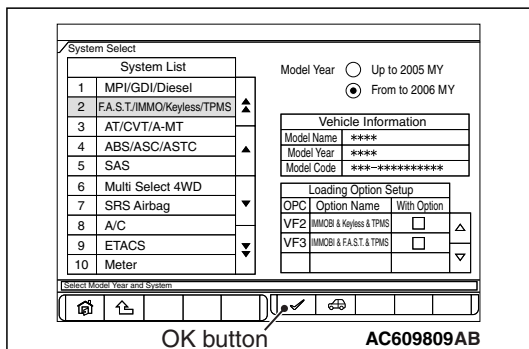
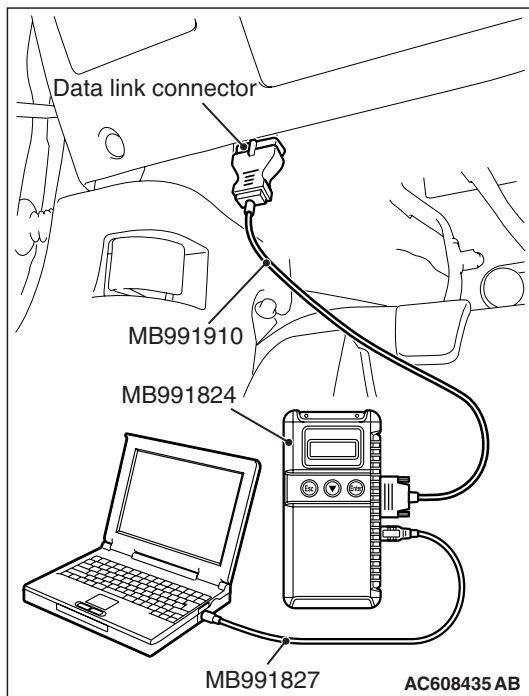

Option: When IMMOBI & F.A.S.T. & TPMS is selected

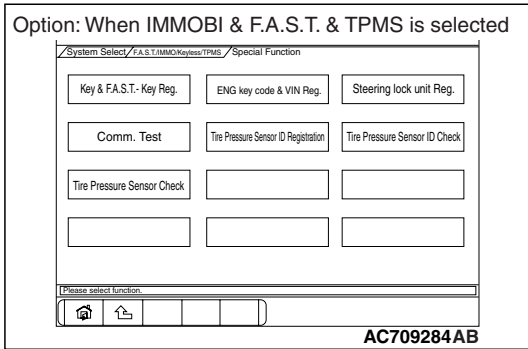

**AC709284AB**

10. Select "ENG key code & VIN Reg." from the "Special Function" screen.

Option: When IMMOBI & Keyless & TPMS is selected

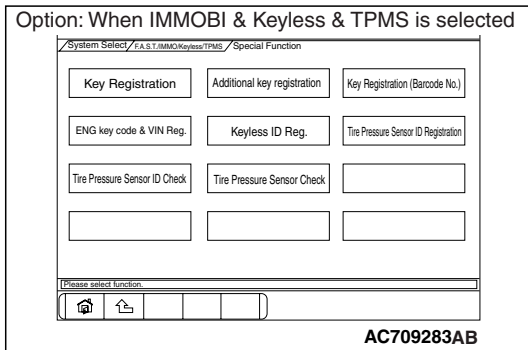

**AC709283AB**

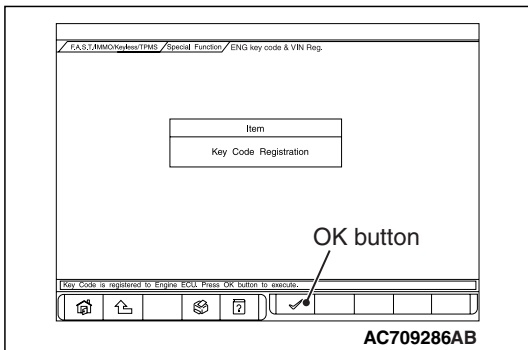

**AC709286AB**

11. Push the OK button after "ENG key code & VIN Reg." is displayed.  
12. Push the OK button after "Completed. Press the OK button and move to VIN writing function." is displayed.

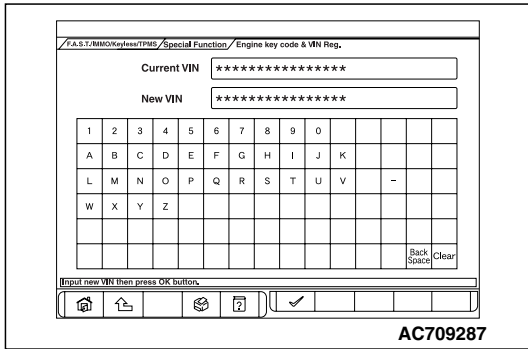

**AC709287**

13. Enter the VIN of registering vehicle and push the OK button.  
14. Push the OK button after "VIN Writing will start. Are you sure?" is displayed.  
15. Return to the previous screen and "In Progress" is displayed at the lower-left corner on the screen.  
16. Push the OK button after "Completed." is displayed.

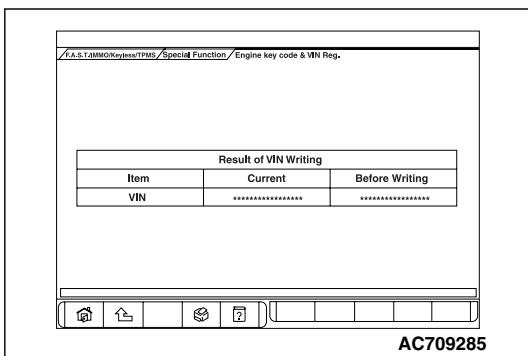

**AC709285**

17. VIN writing result is displayed.  
18. Complete the scan tool MB991958.  
19. Disconnecting the scan tool MB991958 is the reverse of the connecting sequence, making sure that the ignition switch is at the "LOCK" (OFF).  
20. Push the OK button after "Completed." is displayed.  
21. Terminate the scan tool MB991958.  
22. Turn the ignition switch to the "LOCK" (OFF) position and then disconnect scan tool MB991958.

VIN WRITING STEPS FOR WCM AND KOS-ECU

**⚠ CAUTION**

Before the VIN registration to WCM and KOS-ECU, check that the VIN of ECM and vehicle are matched.

**⚠ CAUTION**

Check that diagnostic trouble code B2416 "ECU internal error" is not set. When diagnostic trouble code B2416 "ECU internal error" is set, the WCM and the KOS-ECU cannot store the VIN even if the VIN is written. If this diagnostic trouble code is set, troubleshoot the WCM or the KOS-ECU and repair. Then write the VIN to the WCM or the KOS-ECU.

**⚠ CAUTION**

Before connecting or disconnecting the MB991958: Scan Tool, turn the ignition switch to the "LOCK" (OFF) position. Connect scan tool MB991958 to the 16-pin data link connector as follows.

*NOTE: For details on how to use scan tool MB991958, refer to the "M.U.T.-III Owner's Manual."*

1. Ensure that the ignition switch is at the "LOCK" (OFF) position.
2. Start up the personal computer.
3. Connect special tool MB991827 to special tool MB991824 and the personal computer.
4. Connect special tool MB991910 to the special tool MB991824.
5. Connect special tool MB991910 to the data link connector of the vehicle.
6. Turn the special tool MB991824 power switch to the "ON" position.

*NOTE: When the special tool MB991824 is energized, the special tool MB991824 indicator light will be illuminated in a green color.*

7. Start the "M.U.T.-III system" on the personal computer and turn the ignition switch to the "ON" position.
8. Select "F.A.S.T./IMMO/Keyless/TPMS" button from the "System Select" screen. Then, select the applicable option code item and push the OK button.
9. Select "Coding" on the next screen.

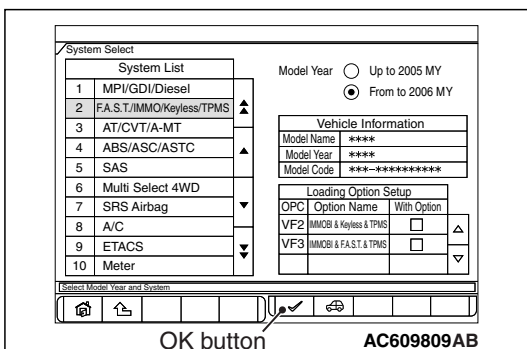
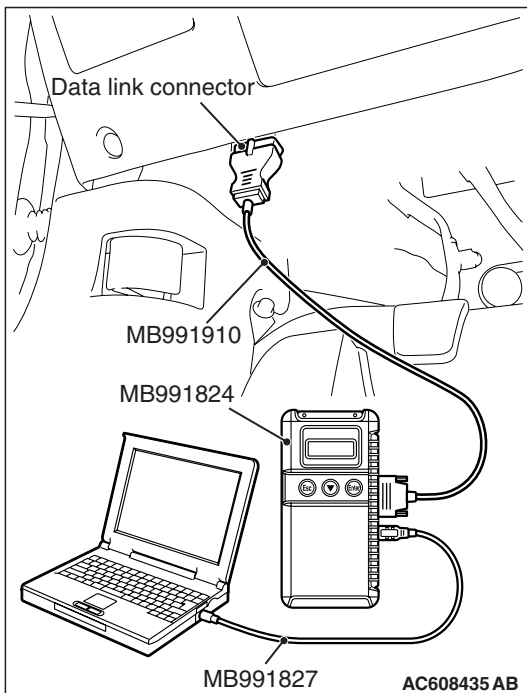

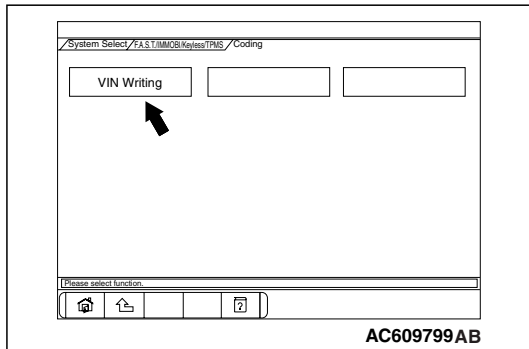

10. Select "VIN Writing" on "Coding" screen.

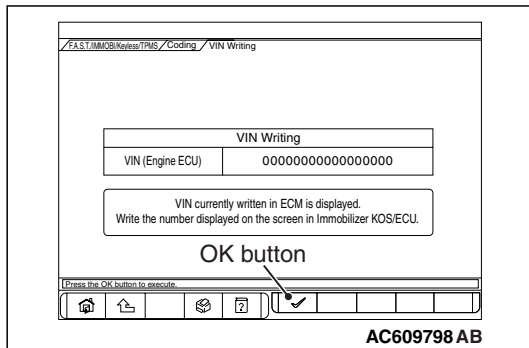

11. Push the OK button after the VIN written in the engine control module is displayed.

12. Push the OK button after "VIN Writing will start. Are you sure?" is displayed.

13. Push the OK button after "Completed." is displayed.

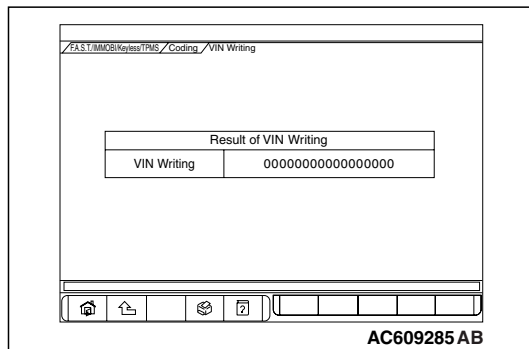

14. Result of VIN writing is displayed.

15. Register the other ID code. (Refer to GROUP 42B, Troubleshooting –ID Code Registration Judgment Table [P.42B-12](#) <Vehicles with KOS> or GROUP 42C, Troubleshooting –ID Code Registration Judgment Table [P.42C-9](#) <Vehicles with WCM>.)

## **INITIALIZATION PROCEDURE FOR LEARNING VALUE IN MFI ENGINE**

M1001011700826

When the following service is performed, initialize the learning value.

- At replacing engine assembly
- At replacing throttle body and at cleaning
- At replacing knock sensor

## **INITIALIZATION PROCEDURE**

### **Required Special Tools:**

- MB991958: Scan Tool (M.U.T.-III Sub Assembly)
  - MB991824: V.C.I.
  - MB991827: M.U.T.-III USB Cable
  - MB991910: M.U.T.-III Main Harness A

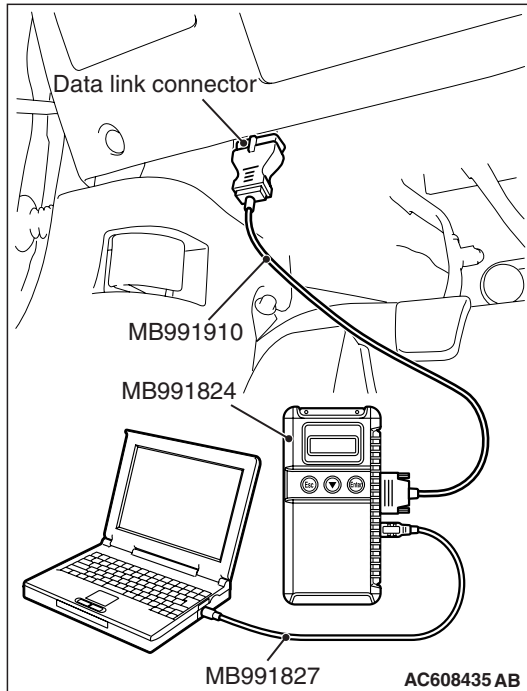

### ⚠ CAUTION

- To prevent damage to scan tool MB991958, always turn the ignition switch to the "LOCK" (OFF) position before connecting or disconnecting scan tool MB991958.
- When the learning value for MFI engine is initialized, the initial learning value for engine timing chain elongation is also initialized. Thus, the initial learning value for timing chain elongation must be stored in scan tool MB991958 before working. If the initial learning value for timing chain elongation is not stored and the learning value for MFI engine is initialized, the visual check of the timing chain elongation must be carried out (Refer to GROUP 11A, Engine Mechanical –On-vehicle Service –Timing Chain Elongation Visual Check P.11A-17). At that time, if the timing chain elongates more than the specified value, the timing chain can possibly interfere the other parts and damage the engine before the ECM detects the timing chain elongation.

*NOTE: When the engine ASSY is replaced, the timing chain is simultaneously replaced. Thus, it is not necessary to perform Step 3 and 9.*

1. After the ignition switch is in "LOCK" (OFF) position, connect scan tool MB991958 to the diagnosis connector.
2. Turn the ignition switch to the "ON" position.
3. The initial learning value for timing chain elongation must be stored in scan tool MB991958 (Refer to Timing Chain Maintenance P.00-33).
4. Select "MFI" from System select Screen of scan tool MB991958.
5. Select "Special Function" from MFI Screen.
6. Select "Learned value reset" from Special Function Screen.
7. Select "All learned value" from Learned value reset Screen
8. Initialize the learning value by pressing the "OK" button.
9. The stored initial learning value for timing chain elongation during Step 3 must be written into the ECM (Refer to Timing Chain Maintenance P.00-33).
10. After initializing the learning value, the learning value of MFI engine idling is necessary. (Refer to Learning Procedure For Idling In MFI Engine P.00-32).

## ENGINE IDLING LEARNING PROCEDURE

M1001011800920

### PURPOSE

When the ECM is replaced, or when the learned value is initialized, the idle may not be stabilized. Carry out the learning method by following the procedures below.



## LEARNING PROCEDURE

1. Start the engine and warm to reach 80° C (176° F) or more.  
*NOTE: When the engine coolant temperature is 80° C (176° F) or more, the warm-up is not needed if the ignition switch is in "ON" position once.*
2. Turn the ignition switch to "LOCK" (OFF) position.
3. After 10 seconds or more, start the engine again.
4. For 10 minutes, carry out the idling under the condition shown below and then confirm the engine idles normally.
  - Transaxle: Neutral (P range on vehicles with TC-SST)
  - Operation in ignition-related, fan and attachments: Not to be operated
  - Engine coolant temperature: 80° C (176° F) or more*NOTE: If the engine stalls while idling, check for a dirty (on the throttle valve) of the throttle body and clean if needed. Then perform the service from Procedure 1 again.*

## INITIALIZATION PROCEDURE FOR THROTTLE ACTUATOR CONTROL MOTOR

When the battery cable is disconnected and reconnected, throttle actuator control motor valve (Fully closed position) is eliminated, so that the throttle valve opening angle control would not be performed correctly. When the battery cable is disconnected and reconnected, initialize the throttle actuator control motor using the following procedure.

1. Turn the ignition switch to the "ON" position then, turn the ignition switch to "LOCK" (OFF) position.
2. For 10 seconds or more, keep the ignition switch in "LOCK" (OFF) position.

## TIMING CHAIN MAINTENANCE

M1001016500021

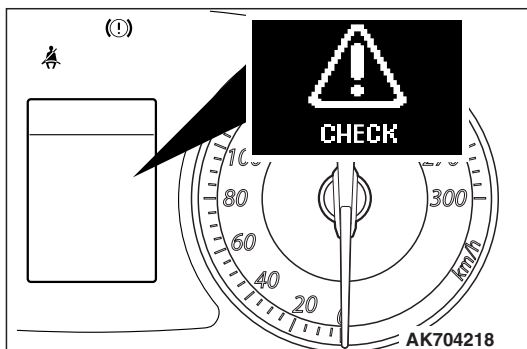

If the vehicle equipped with 4B11-T/C engine continues the rough driving like competitive running<sup>\*1</sup>, the amount of carbon mixed into the engine oil tends to increase. This can possibly cause the timing chain to gradually elongate. To prevent this, the function or logic monitoring the amount of elongation of the timing chain is integrated into the ECM. When the ECM detects the elongation of the timing chain, the warning is shown on the multi-information display of combination meter as shown in the illustration. This gives the driver the information that the visual check of the elongation of the timing chain is necessary. If this warning is continuously neglected, the timing chain can possibly interfere with the other engine components, resulting in the engine damaged.

*NOTE: \*1: The competitive running means the running that constantly repeats the cycle of the full opened position of the accelerator pedal and the full closed position of the accelerator pedal.*

The ECM stores the timing chain conditions as the learning value when the timing chain is installed. The ECM stores the amount of elongation of the timing chain in the EEPROM as the current learning value, compared with the learning value. The ECM judges that the visual check of the elongation of the timing chain is necessary when the current learning value exceeds the specified value. Thus, use the scan tool MB991958 to always carry out the maintenance of the learning value related to the timing chain that is stored by the ECM after the following service.

Service	Maintenance items by scan tool MB991958	Maintenance purpose
ECM replacement	<ul style="list-style-type: none"> <li>• Learned value Read&amp;Save <sup>*2</sup></li> <li>• Write learned value (Changed ECU)<sup>*2</sup></li> </ul>	The purpose is that the initial value regarding the amount of elongation of the timing chain stored by the current ECM is loaded in the scan tool MB991958, and then written into the new ECM. This allows the ECM to appropriately monitor the amount of elongation of the timing chain after the ECM replacement.
Visual check of elongation of timing chain	Learned value reset	The purpose is that the initial value stored by the current ECM is initialized after the visual check of the elongation of the timing chain by illuminating the warning lamp, whether or not the timing chain is replaced.
Timing chain or engine ASSY replaced	Learned value reset	The purpose of this procedure is that the initial learning value stored by the current ECM is initialized when the timing chain or the engine ASSY (the timing chain is also replaced with a new one.) is replaced. This allows the ECM to appropriately monitor the amount of elongation of the timing chain.
Initializing learning value for MFI engine	<ul style="list-style-type: none"> <li>• Learned value Read&amp;Save</li> <li>• Write learned value (Changed ECU)</li> </ul>	When learning value for MFI engine is initialized, initial learning value for timing chain elongation is also initialized. Thus, initial learning value for timing chain elongation must be stored before initializing learning value for MFI engine.

**NOTE:** <sup>\*2</sup>: The visual check of the elongation of the timing chain must be carried out using the scan tool MB991958 under the following conditions (Refer to GROUP 11A, Engine Mechanical –On-vehicle Service – Timing Chain Elongation Visual Check [P.11A-17](#)). When the initial value cannot be written into the new ECM because of the ECM malfunction.

## LEARNED VALUE READ&SAVE AND WRITE LEARNED VALUE (CHANGED ECU)

### Required Special Tools:

- MB991958: Scan Tool (M.U.T.-III Sub Assembly)
  - MB991824: V.C.I.
  - MB991827: M.U.T.-III USB Cable
  - MB991910: M.U.T.-III Main Harness A

**⚠ CAUTION**

To prevent damage to scan tool MB991958, always turn the ignition switch to the "LOCK" (OFF) position before connecting or disconnecting scan tool MB991958.

1. After the ignition switch is in "LOCK" (OFF) position, connect scan tool MB991958 to the diagnosis connector.
2. Turn the ignition switch to the "ON" position.
3. Select "MFI" from System select Screen of scan tool MB991958.

4. Select "Special Function" from MFI Screen.
5. Select "Timing chain maintenance" from Special Function Screen.

6. Select "Learned value Read&Save" from Timing chain maintenance Screen.

7. Press "OK" to store the learning value file.

*NOTE: When the learning value file is appropriately stored, "Learned value Save Complete" is shown on the screen of the scan tool MB991958.*

*NOTE: Calculating the amount of elongation of the timing chain by the ECM takes the time. Thus, the file cannot be stored for a while after the ECM initialization or replacement.*

8. Replace the ECM.

9. Select "Learned value reset" from Timing chain maintenance Screen.

10. Select the learning value file stored during Step 3 to write the learning value.

*NOTE: Use only the learning value file stored during Step 3 without using any other files.*

*NOTE: When the learning value is appropriately written, "Learned value writing Completed." is shown on the screen of the scan tool MB991958.*

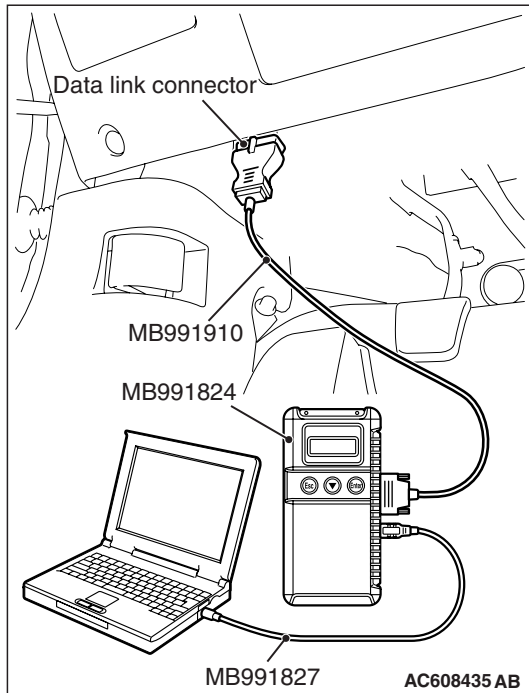

**LEARNED VALUE RESET****Required Special Tools:**

- MB991958: Scan Tool (M.U.T.-III Sub Assembly)
  - MB991824: V.C.I.
  - MB991827: M.U.T.-III USB Cable
  - MB991910: M.U.T.-III Main Harness A

**⚠ CAUTION**

To prevent damage to scan tool MB991958, always turn the ignition switch to the "LOCK" (OFF) position before connecting or disconnecting scan tool MB991958.

1. After the ignition switch is in "LOCK" (OFF) position, connect scan tool MB991958 to the diagnosis connector.
2. Turn the ignition switch to the "ON" position.
3. Select "MFI" from System select Screen of scan tool MB991958.
4. Select "Special Function" from MFI Screen.
5. Select "Timing chain maintenance" from Special Function Screen.
6. Select "Learned value reset" from Timing chain maintenance Screen.
7. Press "OK" to reset the learning value.

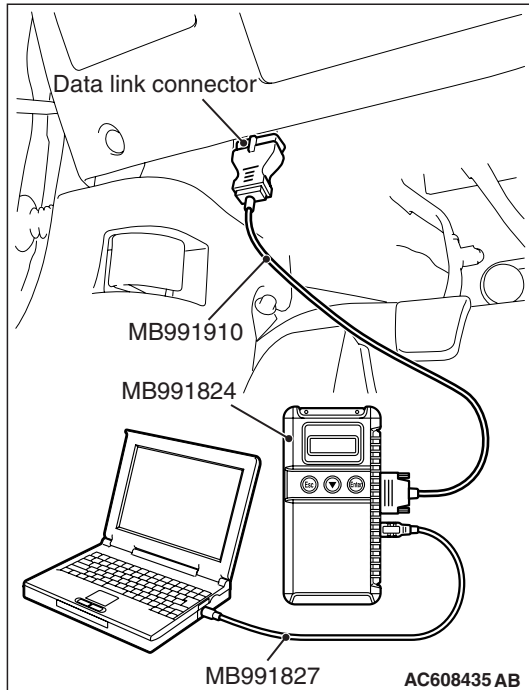

## TEST/LIMIT VALUE READOUT

### Required Special Tools:

- MB991958: Scan Tool (M.U.T.-III Sub Assembly)
  - MB991824: V.C.I.
  - MB991827: M.U.T.-III USB Cable
  - MB991910: M.U.T.-III Main Harness A

### **⚠ CAUTION**

To prevent damage to scan tool MB991958, always turn the ignition switch to the "LOCK" (OFF) position before connecting or disconnecting scan tool MB991958.

1. After the ignition switch is in "LOCK" (OFF) position, connect scan tool MB991958 to the diagnosis connector.
2. Turn the ignition switch to the "ON" position.
3. Select "MFI" from System select Screen of scan tool MB991958.
4. Select "Special Function" from MFI Screen.
5. Select "Timing chain maintenance" from Special Function Screen.
6. Select "Test/Limit value readout" from Timing chain maintenance Screen.
7. Read the value of percentage (%) shown on the screen.

*NOTE: The value of percentage (%) shown on the screen is the amount of elongation of the timing chain calculated by the ECM based on the learning value, and thus is not the actual amount. Use this for the reference only.*

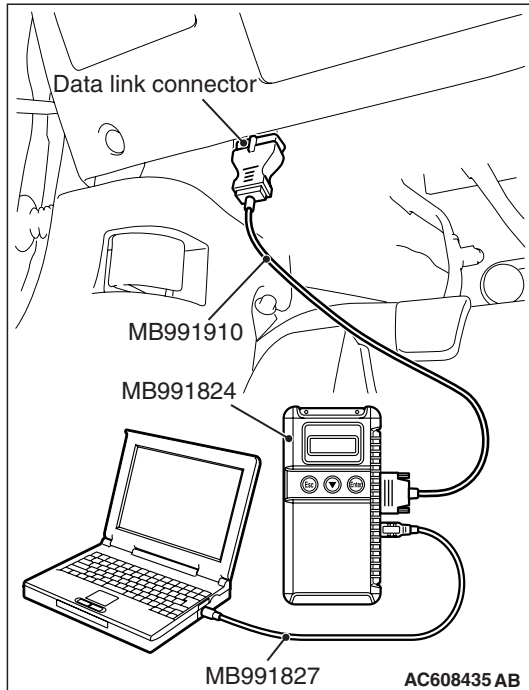

## SERVICING ELECTRICAL SYSTEM

M1001011900433

### **⚠ WARNING**

**Battery posts, terminals and related accessories contain lead and lead compounds. WASH HANDS AFTER HANDLING.**

1. Note the following before proceeding with working on the electrical system.

Never perform unauthorized modifications to any electrical device or wiring. Such modifications might lead to a vehicle malfunction, over-capacity or short-circuit that could result in a fire in the vehicle.

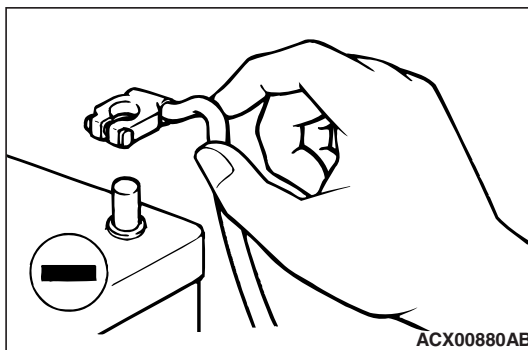

**⚠ CAUTION**

- Before connecting or disconnecting the negative battery cable, be sure to turn the ignition switch to the "LOCK" (OFF) position and turn off the lights (If this is not done, there is the possibility of semiconductor parts being damaged).
  - After completion of the work (and the negative battery terminals is connected), warm up the engine and allow it to idle for approximately 10 minutes under the conditions described below in order to stabilize engine control conditions, and then check to be sure that the idle is satisfactory.
    - Engine coolant temperature: 85 –95° C (185 –203° F)
    - Lights and all accessories: OFF
    - Transaxle: "P" position
    - Steering wheel: straight-forward position
2. When servicing the electrical system, disconnect the negative cable terminal from the battery.

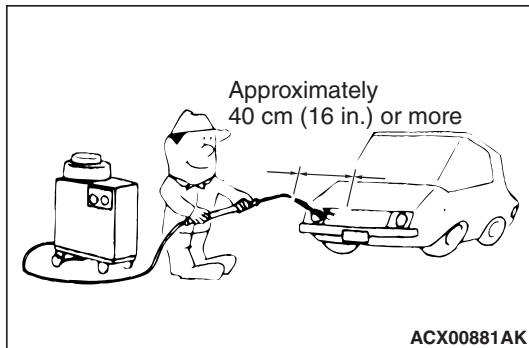
**VEHICLE WASHING**

M1001012000660

1. If high-pressure car-washing equipment or steam car-washing equipment is used to wash the vehicle, be sure to maintain the spray nozzle at a distance of at least approximately 40cm (16 in.) from any plastic parts and all opening parts (doors, luggage compartment, etc.).
2. If high-pressure car-washing equipment or steam car-washing equipment is used to wash the vehicle, be sure to observe the following instructions to prevent damages to the plastic parts.
  - Spray nozzle distance: Approximately 40 cm (16 in.) or more
  - Spray pressure: 3,900 kPa or less
  - Spray temperature: 82 °C (180° F) or less
  - Time of intensive spraying to one point: Within 30 seconds

**APPLICATION OF ANTI-CORROSION AGENTS AND UNDERCOATS**

M1001011000117

Be careful not to apply oil or grease to the heated oxygen sensor. If applied, the sensor may malfunction. Protect the heated oxygen sensor with a cover before applying anti-corrosion agent, etc.

## SCAN TOOL (MULTI USE TESTER { M.U.T.-III } SUB ASSEMBLY)

M1001012400226

### CAUTION

Turn the ignition switch to the "LOCK" (OFF) position before disconnecting or connecting the scan tool.

*NOTE: M.U.T.-III trigger harness is not necessary when pushing V.C.I. ENTER key.*

VEHICLE COMMUNICATION  
INTERFACE (V.C.I.)

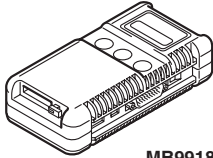

MB991824

M.U.T.-III USB CABLE

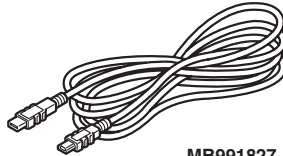

MB991827

M.U.T.-III MAIN HARNESS A

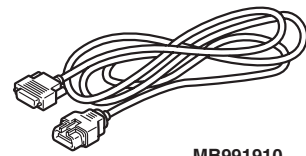

MB991910

M.U.T.-III MAIN HARNESS B

DO NOT USE

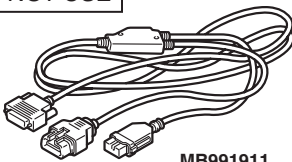

MB991911

M.U.T.-III MAIN HARNESS C

DO NOT USE

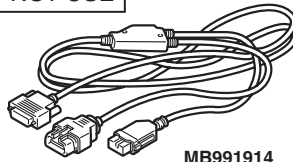

MB991914

M.U.T.-III MEASUREMENT ADAPTER

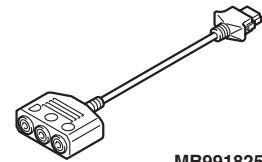

MB991825

M.U.T.-III TRIGGER HARNESS

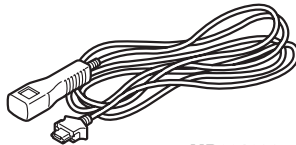

MB991826

AC21088AD

## CODING LIST

M1001015000294

### CAUTION

With the ETACS functions being customized, if any of the ETACS-ECU variant coding and option coding items are changed, the customized contents are reset. In such case, the functions need to be recustomized.

Before troubleshooting, check that the coding data written into the engine control module and ETACS-ECU are normal. If they are not the same as the initial settings, various functions and systems will not work correctly.

## VARIANT CODING

### Required Special Tools:

- MB991958: Scan Tool (M.U.T.-III Sub Assembly)
- MB991824: Vehicle Communication Interface (V.C.I.)

- MB991827: M.U.T.-III USB Cable
- MB991910: M.U.T.-III Main Harness A (Vehicles with CAN communication system)

The coding data can be checked by operating scan tool MB991958.

*NOTE: For details on how to use the scan tool MB991958, refer to the "M.U.T.-III Owner's manual".*

#### **CAUTION**

**To prevent damage to scan tool MB991958, always turn the ignition switch to the "LOCK" (OFF) position before connecting or disconnecting scan tool MB991958.**

1. Ensure that the ignition switch is at the "LOCK" (OFF) position.
2. Start up the personal computer.
3. Connect special tool MB991827 to special tool MB991824 and the personal computer.
4. Connect special tool MB991910 to special tool MB991824.
5. Connect special tool MB991910 to the data link connector.
6. Turn the power switch of special tool MB991824 to the "ON" position.

*NOTE: When special tool MB991824 is energized, special tool MB991824 indicator light will be illuminated in a green color.*

7. Start the "M.U.T.-III system" on the personal computer.
  8. Turn the ignition switch to the "ON" position.
  9. Select "System select" from the start-up screen.
  10. Select "From 2006 MY" under "Model Year". Check that "Vehicle Information" contents are correct.
  11. On the system list screen, select "MPI/GDI/DIESEL" to check the engine control module data, "AT/CVT/A-MT/TC-SST" to check the TC-SST data, and "ETACS" to check the ETACS-ECU data.
- NOTE: If "Loading Option Setup" list is shown, click appropriate box.*
12. Select "Coding."
  13. Select "Coding information & copy."
  14. If the displayed coding information is different from the corresponding initial setting in the list, replace the ECU with a correctly coded one. For replacement of the engine control module, refer to GROUP 13A, engine control module [P.13A-920](#). For replacement of the TC-SST-ECU\*, refer to GROUP 22C, transaxle assembly [P.22C-341](#). For replacement of the ETACS-ECU, refer to GROUP 54A, ETACS [P.54A-676](#).

*NOTE: \*: TC-SST-ECU cannot be disassembled. Thus, replace the transaxle assembly.*

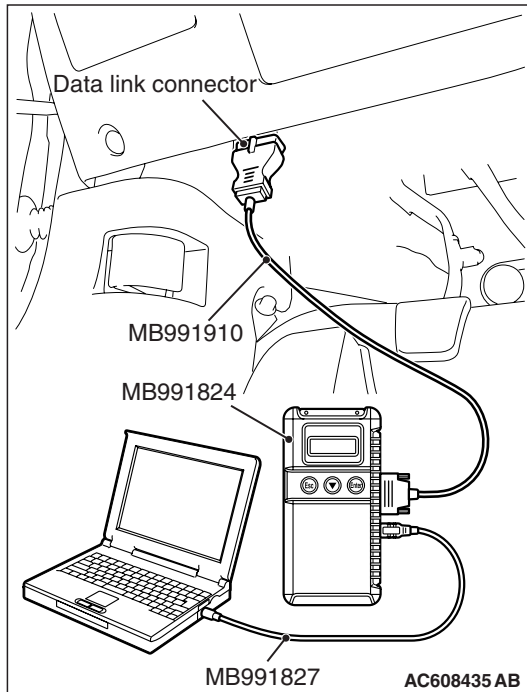



**ENGINE CONTROL MODULE CODING DATA LIST**

<b>Item name</b>	<b>Initial value</b>
Final gear ratio	5MT/6MT or 4.062
Tire circumference	2026mm
IMMOBILIZER	Present
ABS	Not present
A.S.C.	Present
S/W variation	No.1

**TC-SST-ECU CODING DATA LIST**

<b>Item name</b>	<b>Initial value</b>
Vehicle line	LANCER EVO
Destination	U.S.
Tire size	245/40R18
Cruise control	Present
A.S.C.	Present
Turbo charger	T/C(INCONEL-AL)

**ETACS-ECU CODING DATA LIST**

<b>Item name</b>	<b>Initial value</b>
Vehicle line	LANCER EVO
Model year	(Displays the model year)
Destination	U.S.
Transaxle	5MT or TC-SST
Engine type	D4 V.V.T. 2.0L TC
Engine power	Normal
Handle side	LHD
Chassis Type for A.S.C.	Type 1
Deadlock Button Operation	2 or Not present
Final drive	AWD FF Base
Transfer	ACD
IG off delay control	Disabled <Vehicles without TC-SST> or Enable <Vehicles with TC-SST>
Tire size	-
Tire circumference	2026mm
Fuel tank	Not used
DRL *1 type	Dimming DRL w/ P <halogen type> or IndependentDRL/P <discharge type>
Smart entry system	Not present or Type A or Type C

Item name	Initial value
TPMS* <sup>1</sup>	Present
Keyless entry	Present
Air bag Auto Hazard	Not Present
Immobilizer	Type A <Vehicles for CANADA> or Type B <Vehicles for USA>
Cruise control	Present
Corner sensor	Not present
Headlight auto leveling device	Not present
Oil level warning	Not present
Water separate warning	Not present
Speed meter scale	Not used
Idle neutral control	Not used
ENG-CVT unit control	Not used
INVECS control	Not used
Look-up slip control	Not used
Side air bag	Present
ACC	Default disabled
Number of speaker* <sup>2</sup>	Premium or 6 speakers
Seat material* <sup>2</sup>	Fabric or Leather
Auto light control* <sup>2</sup>	No/Cng Ng or Hi RLS/chg Ng
Front differential	Helical
Rear differential	AYC
Power window type	Type P4
Sun roof type	Not present or Type S4
WCM	Present
OCM	Present
ORC	Present
A/C	Present
AUDIO* <sup>2</sup>	Not present or Present
AND* <sup>2</sup>	Not present or Present
VES	Not used
DISP	Not used
NAVI	Not used
CAMERA	Not present
TUNER	Not used

**GENERAL  
PRECAUTIONS BEFORE SERVICE**

**00-43**

<b>Item name</b>	<b>Initial value</b>
Electric Slide door (Left)	Not present
Electric Slide door (Right)	Not present
ETG	Not present
MSMD	Not used
HFM* <sup>2</sup>	Not present or Present
ABS	Not present
A.S.C.	Present
SAS	Present
AWD	Not present
TCM	Not present <Vehicles without TC-SST> or Present <Vehicles with TC-SST>
ACTV_STB	Not used
Pre-Crush	Not used
EPS	Not present
ACDAYC	Present
Power window Dr	Present
Power window As	Not present
Power window RR	Not present
Power window RL	Not present
Power window BK	Not used
Sun roof	Not present or Present
RLS* <sup>2</sup>	Not present or Present
IG key illumination	W/ getting off
Turn signal bulb	21W+21W+5W
Rear wiper	Disabled
Fold mirror	Disabled
Headlight	4 beams* <sup>3</sup>
Comfort Hazard	Disabled
Headlight washer	Disabled
Front fog light mode	A spec.
Front fog light* <sup>2</sup>	Present
Rear fog light* <sup>2</sup>	NotPresent/ChgOk
Room light delay timer /door&H/L	Long
Room light by H/L	Full
Gate/Trunk light	Mode-1 (trunk)

Item name	Initial value
Headlight auto cut mode	C-spec
Headlight auto cut	Enable
Door lock system	A-spec(NAS)
Auto door lock/unlock	Disabled
key remainder unlock	B-spec/Dr and As
Horn type* <sup>2</sup>	Dual horn
Gate/trunk opener mode	Present
Cooling fan	Relay control
Security alarm mode	C-spec(US)
Security alarm function	Present/Chg Ng
Pre-alarm	Not present
Multi mode RKE	Disabled
Gate/Trunk	Trunk type
Manner Switch* <sup>2</sup>	NotPresent/ChgNg
Remote engine starter* <sup>2</sup>	NotPresent/ChgNg
Panic Alarm	Enable
Front wiper	Speed Sensitive or Rain Sensitive
Comfort flasher type	Present/Chg Ok
Dome light center switch	Not present
Wiper washer check bulb* <sup>2</sup>	Present
AUDIO/S.RADIO type	Other
H/L leveling type	Not present
AFS/ACL* <sup>1</sup> type	Not present
ESS	Not present
Compressor type* <sup>2</sup>	Scroll 90cc
Temperature type	Celsius or Fahrenheit
Rear view camera	Not present
Nose view camera	Not present
Side view camera	Not present
Average speed	Available
Vehicle language status	English
Fuel amount	Not used
Fuel consumption scale	L/100km or MPG(US)
Speed gauge tolerance	U.S.
Coolant temp gauge threshold	Normal

**GENERAL  
PRECAUTIONS BEFORE SERVICE**

**00-45**

<b>Item name</b>	<b>Initial value</b>
Frost warning threshold	U.S.
Distance to empty	Available
Average fuel consumption	Available
Instant fuel consumption	Available
Time traveled	Not available
Distance traveled	Not available
Fuel used	Not available
Trip autoreset IG OFF	Available
Variable Speed Alarm	Not available
Rest reminder	Available
Instant speed	Not available
Seat belt reminder type	Type 1
Seat belt reminder flashing	Available
Seat belt reminder indicator	D&P independent
Reverse alarm	Not available
Key reminder	Available
Lighting monitor	Available
GCC speed alarm	Not available
Condition tone alarm	Not available
Rent-a-car mode IG-OFF always	Available
Rent-a-car mode IG-OFF door open	Available
Service reminder schedule table	NAS 20
ACD control display	Not used
TPMS information	32 psi
Horn chirp by keyless	Present/Chg Ok
Rear S/R Unlock Output	Not present
Trailer turn detection	Present
Shift Lever	Not present <Vehicles without TC-SST> or Present <Vehicles with TC-SST>
AFS/ACL	Not present
Satellite Radio* <sup>2</sup>	Not present or Present
Fuel tank type	Not used
F.A.S.T. auto lock customize	Not used
DRL function	Present/Chg Ng
FACU	Not present
S-AWC Control display	Available

**TSB Revision**

Item name	Initial value
Diesel particulate filter	Not present
Language mode	Available
WSS	Not present
DOOR UNLOCK MODE CUSTOMIZE	Disabled
RLS overwipe type	Type 1
RLS WS type	Type 2 (Green)

**NOTE:**

- <sup>\*1</sup>: TPMS is an abbreviation of Tire Pressure Monitoring System, DRL of Daytime Running Light and AFS of Adaptive Front lighting System.
- <sup>\*2</sup>: The setting can be changed by the option coding. Refer to [P.00-46](#).
- <sup>\*3</sup>: Although the dual-light discharge type is employed, it is displayed as "4 beams"

**OPTION CODING****⚠ CAUTION**

- If there is any item indicated by the option coding after equipment change, set ETACS-ECU so that the option coding data corresponds with the equipment content. Functions and systems do not work normally if the setting does not correspond with the equipment.
- With the ETACS functions being customized, if any of the ETACS-ECU variant coding and option coding items are changed, the customized contents are reset. In such case, the functions need to be recustomized.

The ETACS-ECU option coding data can be checked or changed by operating scan tool MB991958.

- How to check option coding data
  1. Connect the scan tool MB991958. Refer to [P.00-39](#).
  2. Turn the ignition switch to the "ON" position.
  3. Select "System select" from the start-up screen.
  4. Select "From 2006 MY" under "Model Year". Check that "Vehicle Information" contents are correct.
  5. Select "ETACS" from "System List", and then press "OK" button.

*NOTE: If "Loading Option Setup" list is shown, click appropriate box.*

6. Select "Coding."
  7. Select "Option Coding Information."
  8. Check the displayed option coding information.
- How to change option coding data
    1. Connect the scan tool MB991958. Refer to .
    2. Turn the ignition switch to the "ON" position.
    3. Select "System select" from the start-up screen.

4. Select "From 2006 MY" under "Model Year". Check that "Vehicle Information" contents are correct.
5. Select "ETACS" from "System List", and then press "OK" button.

*NOTE: If "Loading Option Setup" list is shown, click appropriate box.*

6. Select "Coding."
7. Select "Option Coding."
8. Change to correct option coding data.

**LIST**

<b>Item name</b>
Number of speaker
Seat material
Auto light control
AUDIO (CAN)
AND
HFM (hands free-ECU)
Rain Light Sensor
Front fog light
Rear fog light
Horn type
Manner switch
Remote engine starter
Wiper washer check bulb
Compressor type
Satellite Radio
DRL function
Keyless

**BOLTS AND NUTS WITH STABILIZER FOR COEFFICIENT OF FRICTION**

M1001014800082

The bolts and nuts with stabilizer for coefficient of friction have been used for the connections such as the suspension arm and crossmember in order to stabilize the axial force and to ensure the high axial force at bolt/nut connections, resulting in improved reliability.

*NOTE: The bolts and nuts with stabilizer for coefficient of friction mean that the bolts and nuts with surface treatment to stabilize and reduce the coefficient of friction, allowing to achieve the stable axial force and to secure the high axial force with low tightening torque.*

**TOWING AND HOISTING**

M1001000800755

**WRECKER TOWING RECOMMENDATION****FRONT TOWING PICKUP****⚠ CAUTION**

- The vehicle must not be towed by placing only its front wheels on a rolling dolly, because to do so will result in deterioration of the viscous coupling and in the viscous coupling causing the vehicle to jump forward suddenly.
- If this vehicle is towed, use flat bed equipment

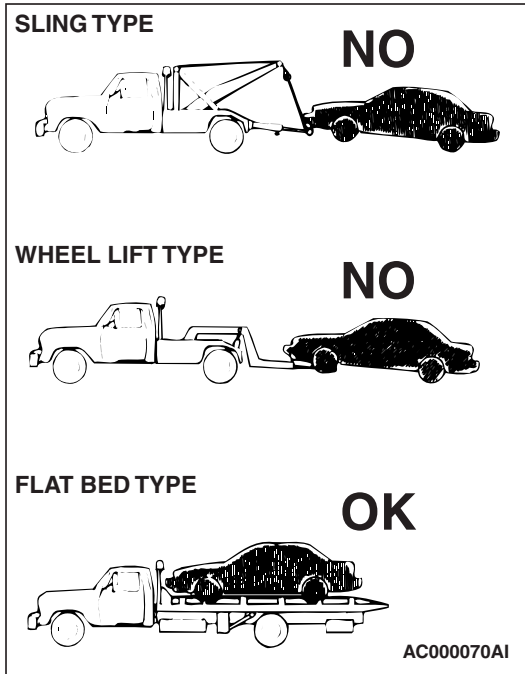
**REAR TOWING PICKUP****⚠ CAUTION**

- The vehicle must not be towed by placing only the rear wheels on a rolling dolly, because to do so will result in deterioration of the viscous coupling causing the vehicle to jump forward suddenly.
- If this vehicle is towed, use flat bed equipment.

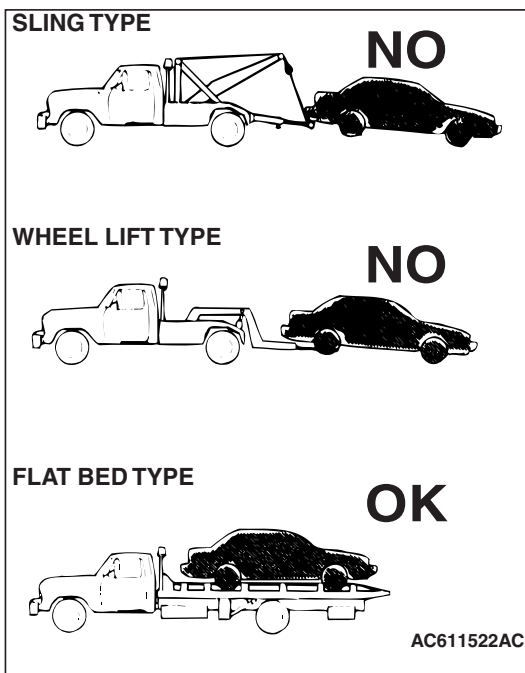



### **TOWING WHEN KEYS ARE NOT AVAILABLE**

When a locked vehicle must be towed and keys are not available, the vehicle may be lifted and towed from the front, provided the parking brake is released. If not released, the rear wheels should be placed on a tow dolly.

### **SAFETY PRECAUTIONS**

The following precautions should be taken when towing the vehicle:

1. Do not lift or tow the vehicle by attaching to or wrapping around the bumper.
2. Any loose, protruding, or damaged parts such as hoods, doors, fenders, trim, etc. should be secured or removed prior to moving the vehicle.
3. Refrain from going under a vehicle when it is lifted by the towing equipment, unless the vehicle is adequately supported by safety stands.
4. Never allow passengers to ride in a towed vehicle.
5. State and local rules and regulations must be followed when towing a vehicle.

## LIFTING, JACKING SUPPORT LOCATION

## FLOOR JACK AND RIGID RACK

**⚠ CAUTION**

- Never place a support at any point other than the specified one, or that point will be deformed.
- For lifting, put rubber or similar material between the side sill and rigid rack, otherwise the side sill area will be damaged.

## FLOOR JACK

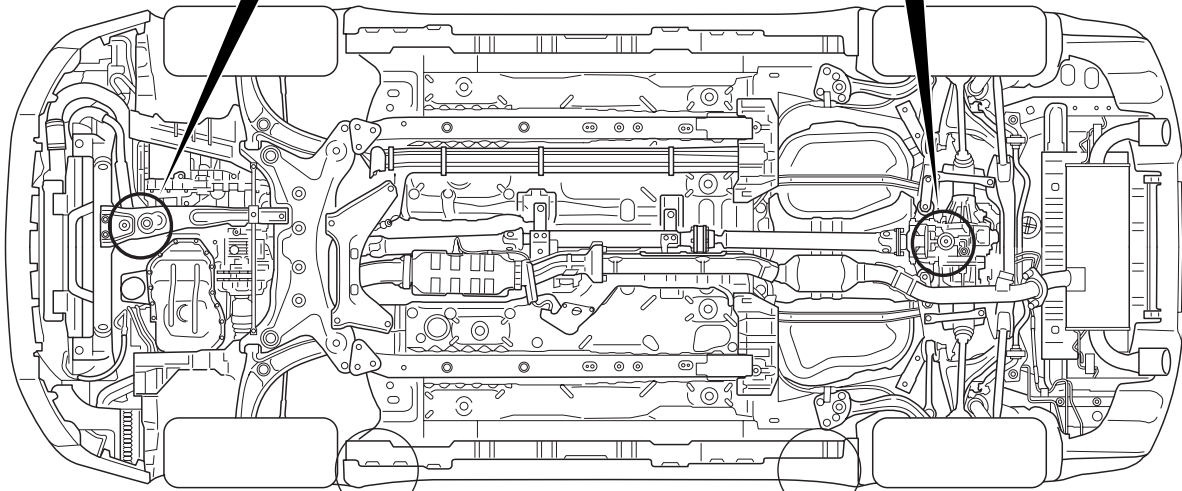
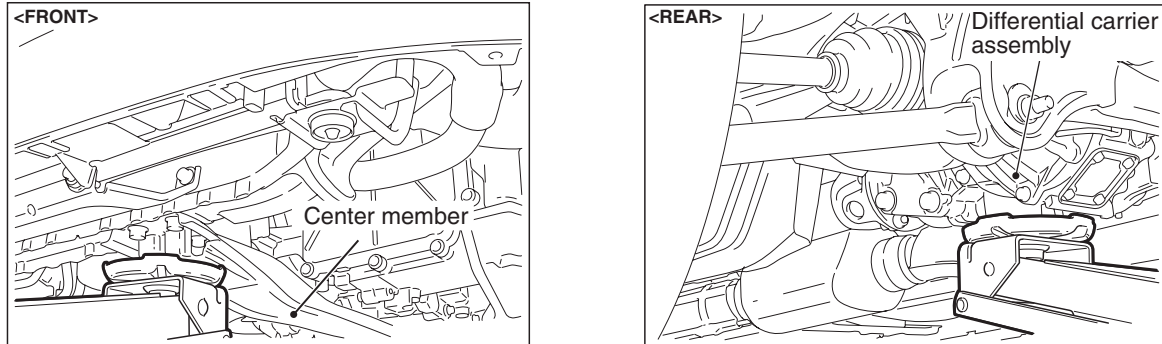

## RIGID RACK

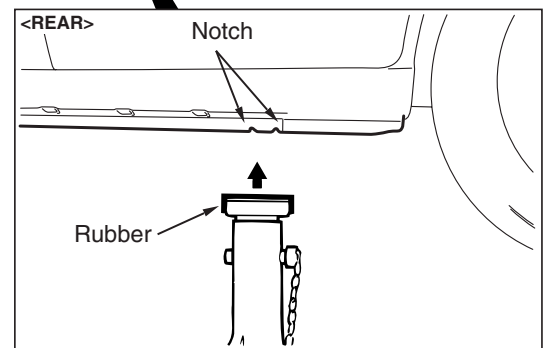
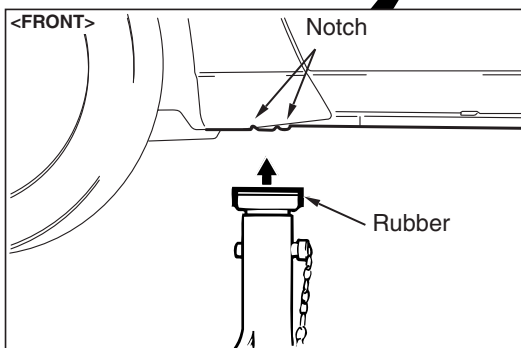

AC709513AB

### POST TYPE

Special care should be taken when raising the vehicle on a frame contact type hoist. The hoist must be equipped with the proper adapters in order to support the vehicle at the proper locations.

**⚠ CAUTION**

When service procedures require removing rear suspension, fuel tank and spare tire, place additional weight on the rear end of vehicle, or anchor vehicle to hoist to prevent tipping when the location of the center of gravity changes.

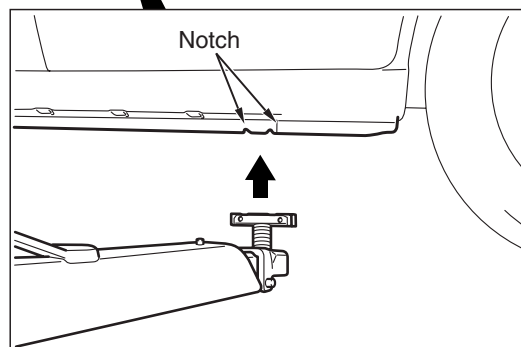
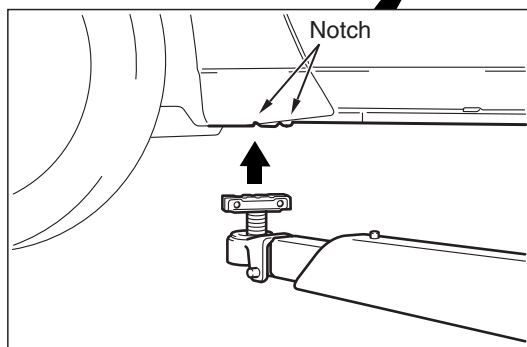
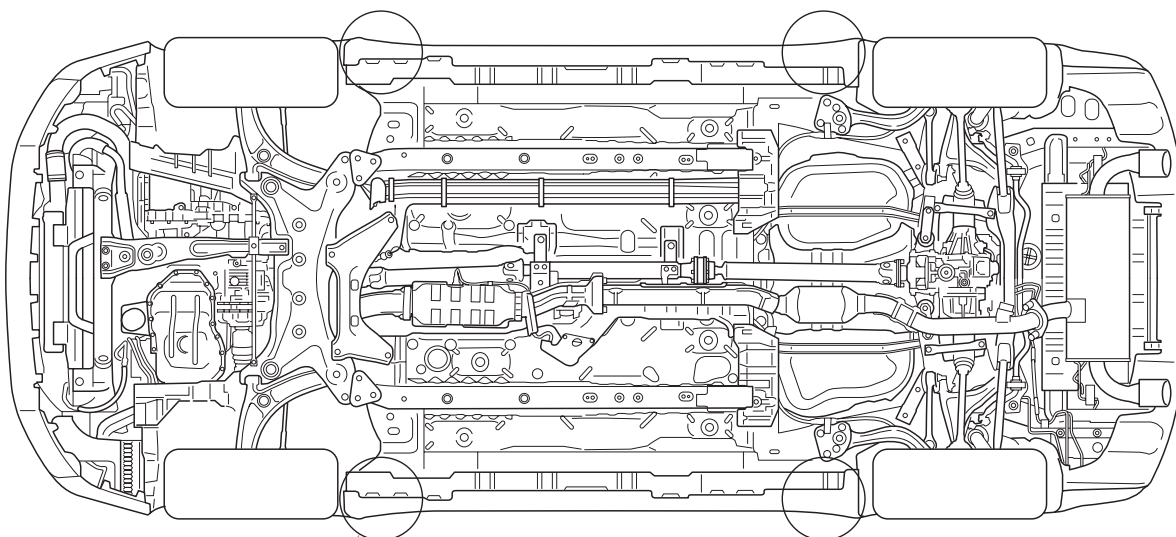

AC709514AB

## GENERAL DATA AND SPECIFICATIONS

M1001000902565

## VEHICLES FOR USA

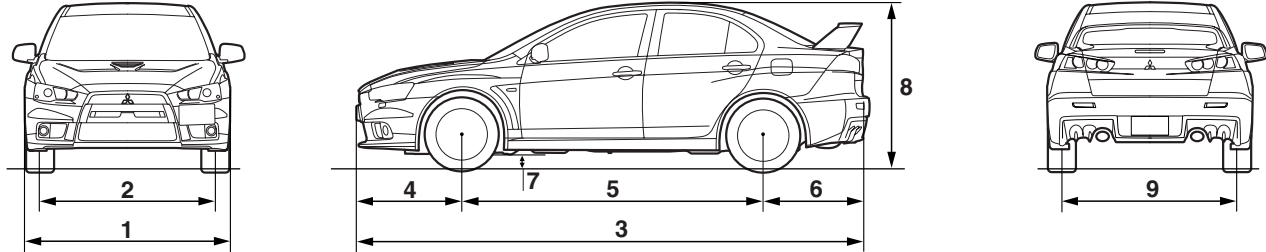

AC710509 AC

Item			CZ4AS		
			NGFZL2M	MGFZL2M	MPFZL2M
Vehicle dimension mm (in)	Overall width	1	1,810 (71.3)	1,810 (71.3)	1,810 (71.3)
	Tread-front	2	1,545 (60.8)	1,545 (60.8)	1,545 (60.8)
	Overall length	3	4,495 (177.0)	4,495 (177.0)	4,495 (177.0)
	Overhang-front	4	910 (35.8)	910 (35.8)	910 (35.8)
	Wheelbase	5	2,650 (104.3)	2,650 (104.3)	2,650 (104.3)
	Overhang-rear	6	935 (36.8)	935 (36.8)	935 (36.8)
	Ground clearance	7	135 (5.3)	135 (5.3)	135 (5.3)
	Overall height (unladen)	8	1,480 (58.3)	1,480 (58.3)	1,480 (58.3)
	Tread-rear	9	1,545 (60.8)	1,545 (60.8)	1,545 (60.8)
Vehicle weight kg (lb)	Curb weight		1,595 (3,517)	1,620 (3,572)	1,630 (3,594)
	Gross vehicle weight rating		2,060 (4,542)	2,060 (4,542)	2,060 (4,542)
	Gross axle weight rating-front		1,080 (2,381)	1,080 (2,381)	1,080 (2,381)
	Gross axle weight rating-rear		1,050 (2,315)	1,050 (2,315)	1,050 (2,315)
Seating capacity			5	5	5
Engine	Model No.		4B11	4B11	4B11
	Piston displacement cm <sup>3</sup> (cu in)		1,998 (121.9)	1,998 (121.9)	1,998 (121.9)
	Maximum output kW/r/min (HP/r/min)		217/6,500 (291/6,500)	217/6,500 (291/6,500)	217/6,500 (291/6,500)
	Maximum torque N·m/r/min (ft-lb/r/min)		407/4,000 (300/4,000)	407/4,000 (300/4,000)	407/4,000 (300/4,000)
Fuel system	Fuel supply system		MFI	MFI	MFI
Transaxle	Model No.		W5M6A	W6DGA	W6DGA
	Type		5M/T	TC-SST	TC-SST
Turning radius m (ft)			5.0 (16.4)	5.0 (16.4)	5.0 (16.4)

**VEHICLES FOR CANADA**

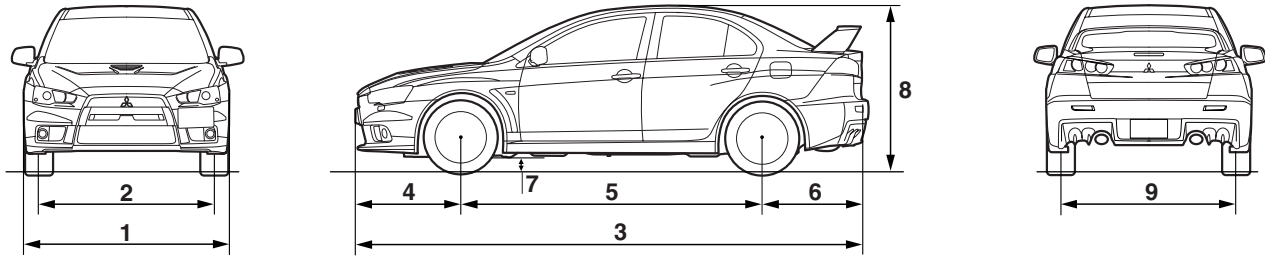

AC710509AC

Item		CY4AS		
		NGFL3M	MPFL3M	
Vehicle dimension mm (in)	Overall width	1	1,810 (71.3)	1,810 (71.3)
	Tread-front	2	1,545 (60.8)	1,545 (60.8)
	Overall length	3	4,495 (177.0)	4,495 (177.0)
	Overhang-front	4	910 (35.8)	910 (35.8)
	Wheelbase	5	2,650 (104.3)	2,650 (104.3)
	Overhang-rear	6	935 (36.8)	935 (36.8)
	Ground clearance	7	135 (5.3)	135 (5.3)
	Overall height (unladen)	8	1,480 (58.3)	1,480 (58.3)
	Tread-rear	9	1,545 (60.8)	1,545 (60.8)
Vehicle weight kg (lb)	Curb weight		1,600 (3,528)	1,635 (3,606)
	Gross vehicle weight rating		2,060 (4,542)	2,060 (4,542)
	Gross axle weight rating-front		1,080 (2,381)	1,080 (2,381)
	Gross axle weight rating-rear		1,050 (2,315)	1,050 (2,315)
Seating capacity			5	5
Engine	Model No.		4B11	4B11
	Piston displacement cm <sup>3</sup> (cu in)		1,998 (121.9)	1,998 (121.9)
	Maximum output kW/r/min (HP/r/min)		217/6,500 (291/6,500)	217/6,500 (291/6,500)
	Maximum torque N·m/r/min (ft-lb/r/min)		407/4,000 (300/4,000)	407/4,000 (300/4,000)
Fuel system	Fuel supply system		MFI	MFI
Transaxle	Model No.		W5M6A	W6DGA
	Type		5M/T	TC-SST
Turning radius m (ft)			5.0 (16.4)	5.0 (16.4)

## TIGHTENING TORQUE

M1001001100964

Each torque value in the table is a standard value for tightening under the following conditions.

1. Bolts, nuts and washers are all made of steel and plated with zinc.
2. The threads and bearing surface of bolts and nuts are all in dry condition.

The values in the table are not applicable:

1. If toothed washers are inserted.
2. If plastic parts are fastened.
3. If bolts are tightened to plastic or die-cast inserted nuts.
4. If self-tapping screws or self-locking nuts are used.

## STANDARD BOLT AND NUT TIGHTENING TORQUE

Thread size		Standard tightening torque		
Nominal bolt diameter (mm)	Pitch (mm)	Head mark "4"	Head mark "7"	Head mark "8"
M5	0.8	2.5 ± 0.5 N·m (23 ± 4 in-lb)	5.0 ± 1.0 N·m (44 ± 9 in-lb)	6.0 ± 1.0 N·m (53 ± 9 in-lb)
M6	1.0	5.0 ± 1.0 N·m (44 ± 9 in-lb)	8.5 ± 1.5 N·m (76 ± 13 in-lb)	10 ± 2 N·m (89 ± 17 in-lb)
M8	1.25	11 ± 2 N·m (98 ± 17 in-lb)	20 ± 4 N·m (15 ± 3 ft-lb)	24 ± 4 N·m (18 ± 3 ft-lb)
M10	1.25	23 ± 4 N·m (17 ± 3 ft-lb)	42 ± 8 N·m (31 ± 6 ft-lb)	53 ± 7 N·m (39 ± 5 ft-lb)
M12	1.25	42 ± 8 N·m (31 ± 6 ft-lb)	80 ± 10 N·m (59 ± 7 ft-lb)	93 ± 12 N·m (68 ± 9 ft-lb)
M14	1.5	70 ± 10 N·m (52 ± 7 ft-lb)	130 ± 20 N·m (96 ± 15 ft-lb)	150 ± 20 N·m (111 ± 14 ft-lb)
M16	1.5	105 ± 15 N·m (78 ± 11 ft-lb)	195 ± 25 N·m (144 ± 18 ft-lb)	230 ± 30 N·m (170 ± 22 ft-lb)
M18	1.5	150 ± 20 N·m (111 ± 14 ft-lb)	290 ± 40 N·m (214 ± 29 ft-lb)	335 ± 45 N·m (247 ± 33 ft-lb)
M20	1.5	210 ± 30 N·m (155 ± 22 ft-lb)	400 ± 60 N·m (295 ± 44 ft-lb)	465 ± 65 N·m (343 ± 48 ft-lb)
M22	1.5	290 ± 40 N·m (214 ± 29 ft-lb)	540 ± 80 N·m (398 ± 59 ft-lb)	630 ± 90 N·m (465 ± 66 ft-lb)
M24	1.5	375 ± 55 N·m (277 ± 40 ft-lb)	705 ± 105 N·m (520 ± 77 ft-lb)	820 ± 120 N·m (605 ± 88 ft-lb)

## FLANGE BOLT AND NUT TIGHTENING TORQUE

Thread size		Standard tightening torque		
Nominal bolt diameter (mm)	Pitch (mm)	Head mark "4"	Head mark "7"	Head mark "8"
M6	1.0	5.0 ± 1.0 N·m (44 ± 9 in-lb)	10 ± 2 N·m (89 ± 17 in-lb)	12 ± 2 N·m (107 ± 17 in-lb)
M8	1.25	13 ± 2 N·m (111 ± 22 in-lb)	24 ± 4 N·m (18 ± 3 ft-lb)	28 ± 5 N·m (20 ± 4 ft-lb)
M10	1.25	26 ± 5 N·m (19 ± 4 ft-lb)	50 ± 5 N·m (37 ± 4 ft-lb)	58 ± 7 N·m (43 ± 5 ft-lb)
M10	1.5	25 ± 4 N·m (18 ± 3 ft-lb)	46 ± 8 N·m (34 ± 6 ft-lb)	55 ± 5 N·m (41 ± 3 ft-lb)
M12	1.25	47 ± 9 N·m (35 ± 6 ft-lb)	93 ± 12 N·m (68 ± 9 ft-lb)	105 ± 15 N·m (78 ± 11 ft-lb)

Thread size		Standard tightening torque		
Nominal bolt diameter (mm)	Pitch (mm)	Head mark "4"	Head mark "7"	Head mark "8"
M12	1.75	43 ± 8 N· m (32 ± 6 ft-lb)	83 ± 12 N· m (61 ± 9 ft-lb)	98 ± 12 N· m (72 ± 9 ft-lb)

## LUBRICATION AND MAINTENANCE

M1001001200529

Maintenance and lubrication service recommendations have been compiled to provide maximum protection for the vehicle owner's investment against all reasonable types of driving conditions. Since these conditions vary with the individual vehicle owner's driving habits, the area in which the vehicle is operated and the type of driving to which the vehicle is subjected, it is necessary to prescribe lubrication and maintenance service on a time frequency as well as mileage interval basis.

Oils, lubricants and greases are classified and graded according to standards recommended by the Society of Automotive Engineers (SAE), the American Petroleum Institute (API) and the National Lubricating Grease Institute (NLGI).

### MAINTENANCE SCHEDULES

Information for service maintenance is provided in the "SCHEDULED MAINTENANCE TABLE." Three schedules are provided; one for "Required Maintenance," one for "General Maintenance" and one for "Severe Usage Service."

The item numbers in "SCHEDULED MAINTENANCE TABLE" correspond to the section numbers in "MAINTENANCE SERVICE."

### SEVERE SERVICE

Vehicles operating under severe service conditions will require more frequent service.

Component service information is included for vehicles operating under one or more of the following conditions:

1. Trailer towing or police, taxi or commercial type operation.
2. Operation of Vehicle
  - (1) Short-trip operation at freezing temperature (engine not thoroughly warmed up)
  - (2) More than 50% operation in heavy city traffic during hot weather above 32° C (90° F)
  - (3) Extensive idling
  - (4) Driving in sandy areas
  - (5) Driving in salty areas

- (6) Driving in dusty conditions
- (7) Driving off-road

### ENGINE OIL

#### **⚠ CAUTION**

**Test results submitted to EPA have shown that laboratory animals develop skin cancer after prolonged contact with used engine oil. Accordingly, the potential exists for humans to develop a number of skin disorders, including cancer, from such exposure to used engine oil. Therefore, when changing engine oil, be careful not to touch it as much as possible. Protective clothing and gloves, that cannot be penetrated by oil, should be worn. The skin should be thoroughly washed with soap and water, or use waterless hand cleaner, to remove any used engine oil. Do not use gasoline, thinners, or solvents.**

Either of the following engine oils should be used: Engine oils displaying ILSAC certification symbol or conforming to the API classification SM. For further details, refer to "LUBRICANTS SELECTION."

### LUBRICANTS AND GREASES

Semi-solid lubricants bear the NLGI designation and are further classified as grades 0, 1, 2, 3, etc. Whenever "Chassis Lubricant" is specified, Multipurpose Grease, NLGI grade Number 2, should be used.

### FUEL USAGE STATEMENT

#### **⚠ CAUTION**

**Using leaded gasoline in this car will damage the catalytic converters and heated oxygen sensors, and affect the warranty coverage validity.**

This vehicle must use unleaded gasoline only. This vehicle has a fuel filler tube which is especially designed to accept only the smaller-diameter unleaded gasoline dispensing nozzle.

**GASOLINE CONTAINING ALCOHOL**

Some gasoline sold at service stations contain alcohol although they may not be so identified. Using fuels containing alcohol is not recommended unless the nature of the blend can be determined as being satisfactory.

Gasohol: A mixture of 10% ethanol (grain alcohol) and 90% unleaded gasoline may be used in your vehicle. If driveability problems are experienced as a result of using gasohol, it is recommended that the vehicle be operated on gasoline.

Methanol: **Do not use gasoline containing methanol (wood alcohol).** Using this type of alcohol can result in vehicle performance deterioration and damage critical parts in the fuel system components. Fuel system damage and performance problems resulting from the use of gasoline containing methanol may not be covered by the new vehicle warranty.

**GASOLINE CONTAINING METHYL TERTIARY BUTYL ETHER (MTBE)**

Unleaded gasoline containing 15% or less MTBE may be used in your vehicle. (Fuel containing MTBE over 15% in volume may cause reduced engine performance and produce vapor lock or hard starting.

**MATERIALS ADDED TO FUEL**

Indiscriminate use of fuel system cleaning agents should be avoided. Many of these materials intended for gum and varnish removal may contain highly active solvents or similar ingredients that can be harmful to gasket and diaphragm materials used in fuel system component parts.

## RECOMMENDED LUBRICANTS AND LUBRICANT CAPACITIES TABLE

M1001001300719

**RECOMMENDED LUBRICANTS**

Lubricant		Specification	Remark
Engine oil		Engine oils displaying ILSAC certification symbol or conforming to the API classification SM	For further details, refer to "LUBRICANTS SELECTION" section.
Engine coolant		Long life antifreeze coolant or an equivalent	-
Transaxle oil	Manual transaxle	DiaQueen NEW MULTI GEAR OIL API classification GL-3, SAE 75W-80	-
	Twin clutch sportronic shift transmission	DIA QUEEN SSTF-1	-
Transfer oil		MITSUBISHI limited slip differential oil (LSD) or equivalent	-
AWC control fluid	Vehicles with ACD (Including hydraulic pipe section)	DIAMOND ATF SP III	Control fluid for ACD/AYC Apply for Reservoir tank
	Vehicles with ACD/AYC (Including hydraulic pipe section)		
AYC differential gear oil (Differential mechanism part)		MITSUBISHI Limited Slip Differential Oil (LSD) or equivalent	-



Lubricant	Specification	Remark
AYC differential gear oil (Torque transfer part)	DIAMOND ATF SP III	-
Power steering fluid	Genuine Mitsubishi Power Steering Fluid	-
Brakes and clutch	Conforming to Brake fluid DOT 3 or DOT 4	-
Engine coolant	Long Life Antifreeze Coolant or an equivalent	-
Door hinges, back door hinges	Grease	-

### LUBRICANT CAPACITY TABLE

Description		Specification
Engine oil dm <sup>3</sup> (qt)	Oil pan (excluding oil filter)	4.8 (5.07)
	Oil cooler	0.5 (0.52)
	Oil filter	0.3 (0.32)
Engine coolant dm <sup>3</sup> (qt)		7.5 (7.93)
Transaxle oil dm <sup>3</sup> (qt)	Manual transaxle (M/T)	2.5 (2.64)
	Twin clutch sport shift transaxle (TC-SST)	7.8 (8.24)
Transfer oil dm <sup>3</sup> (qt)		0.9 (0.95)
ACD and AYC differential fluid dm <sup>3</sup> (qt)		7.1 (7.50)
AYC differential gear oil (Differential mechanism part) dm <sup>3</sup> (qt)		0.55 (0.58)
Power steering fluid dm <sup>3</sup> (qt)		1.0 (1.06)
Fuel tank dm <sup>3</sup> (gal)		55.0 (14.5)

### LUBRICANT SELECTION

#### ENGINE OIL

**⚠ CAUTION**

**Never use nondetergent or straight mineral oil.**

Use only engine oils displaying the ILSAC certification mark ("Starburst" symbol) on the container.

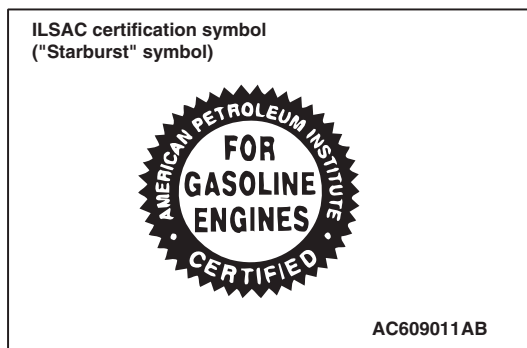

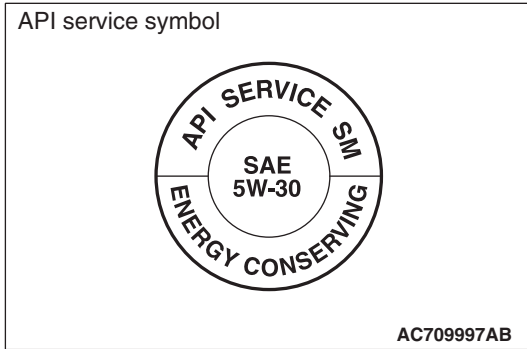

If these oils are not available, an API classification SM or higher can be used.

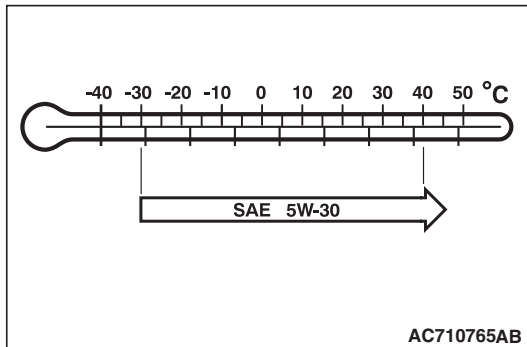

**OIL VISCOSITY**

The SAE grade number indicates the viscosity of the oil. A proper SAE grade number should be selected according to ambient temperature.

**NOTE:**

- SAE 5W-30 engine oil is strongly recommended for optimum fuel economy and cold starting.
- If engine oil other than 5W-30 is used, the engine may be seized by poor lubrication.

**SELECTION OF COOLANT**

**COOLANT**

Relationship between Coolant Concentration and Specific Gravity

**⚠ CAUTION**

- If the concentration of the coolant is below 30%, the anti-corrosion property will be adversely affected. In addition, if the concentration is above 60%, both the anti-freeze and engine cooling properties will decrease, affecting the engine adversely. For these reasons, be sure to maintain the concentration level within the specified range.
- Do not use a mixture of different brands of anti-freeze.

Coolant temperature °C (°F) and specific gravity					Freezing temperature	safe operating temperature	Coolant concentration (Specific volume)
10 (50)	20 (68)	30 (86)	40 (104)	50 (122)	°C (°F)	°C (°F)	%
1.054	1.050	1.046	1.042	1.036	-16 (3.2)	-11 (12.2)	30
1.063	1.058	1.054	1.049	1.044	-20 (-4)	-15 (5)	35
1.071	1.067	1.062	1.057	1.052	-25 (-13)	-20 (-4)	40
1.079	1.074	1.069	1.064	1.058	-30 (-22)	-25 (-13)	45
1.087	1.082	1.076	1.070	1.064	-36 (-32.8)	-31 (-23.8)	50
1.095	1.090	1.084	1.077	1.070	-42 (-44)	-37 (-35)	55
1.103	1.098	1.092	1.084	1.076	-50 (-58)	-45 (-49)	60

**Example**

The safe operating temperature is -15° C (5° F) when the specific gravity is 1.058 at the coolant temperature of 20° C (68° F)

## SCHEDULED MAINTENANCE TABLE

M1001001400880

### SCHEDULED MAINTENANCE SERVICE FOR EMISSION CONTROL AND PROPER VEHICLE PERFORMANCE

Inspection and service should be performed any time a malfunction is observed or suspected.

No.	Emission control system maintenance	Service intervals	Mileage in thousands	15	30	45	60	75	90	105	120	135	150
			Kilometers in thousands	24	48	72	96	120	144	168	192	216	240
			Months	15	30	45	60	75	90	105	120	135	150
1	Fuel system (tank, pipe line and connection, and fuel tank filler tube cap)	Check for leaks			X*		X		X		X		X
2	Fuel hoses	Check condition			X*		X		X		X		X
3	Air cleaner element	Replace	X*	X	X	X	X	X	X	X	X	X	X
4	Evaporative emission control system (except evaporative emission canister)	Check for leaks and clogging				X					X		
5	Spark plugs	Iridium-tipped type	Replace				X				X		
6	Intake and exhaust valve clearance	Inspect and adjust				X					X		
			If valve noise increases, adjust valve clearance										
7	Drive belts (for the generator and power steering oil pump)	Replace		X		X		X		X		X	
8	Exhaust system (connection portion of muffler, muffler pipes and converter heat shields)	Check and service		X*		X		X		X		X	

NOTE: \*: This maintenance is recommended but is not required to maintain the emissions warranty.

## GENERAL MAINTENANCE SERVICE FOR PROPER VEHICLE PERFORMANCE

No.	General maintenance	Service intervals	Mileage in thousands	15	30	45	60	75	90	105	120	135	150
			Kilometers in thousands	24	48	72	96	120	144	168	192	216	240
			Months	15	30	45	60	75	90	105	120	135	150
9	Engine oil	Turbo	Change	Every 5 months or every 8,000 km (5,000 miles)									
10	Engine oil filter	Turbo	Replace	Every 10 months or every 16,000 km (10,000 miles)									
11	Manual transaxle oil	Check oil level		X	X	X	X	X	X	X	X	X	X
		Change			X		X		X		X		X
12	Twin clutch sportronic shift transmission oil	Check oil leaks (If necessary, check the oil level)		X	X	X	X	X	X	X	X	X	X
		Change					X				X		
13	Transfer oil	Check oil level		X	X	X	X	X	X	X	X	X	X
		Change			X		X		X		X		X
14	Reserve tank (for ACD* <sup>1</sup> and AYC* <sup>2</sup> )	Check fluid level		X	X	X	X	X	X	X	X	X	X
15	Engine coolant	Change			X		X		X		X		X
16	Coolant hoses (radiator hose, heater hose)	Inspect			X		X		X		X		X
		Replace					X				X		
17	Disk brake pads, rotors	Inspect for wear		Every 5 months or every 8,000 km (5,000 miles)									
18	Brake hoses	Check for deterioration or leaks		X	X	X	X	X	X	X	X	X	X
19	Ball joint and steering linkage seals	Inspect for grease leaks and damage		X	X	X	X	X	X	X	X	X	X
20	Driveshaft boots	Inspect for grease leaks and damage		Every 5 months or every 8,000 km (5,000 miles)									
21	Suspension system	Inspect for looseness and damage		Every 5 months or every 8,000 km (5,000 miles)									
22	Rear axle oil (for differential part)	Change			X		X		X		X		X
23	Rear axle oil (for torque transfer part)	Change			X		X		X		X		X
24	Tires	Rotate		Every 5 months or every 8,000 km (5,000 miles)									
25	Air purifier filter	Replace		X	X	X	X	X	X	X	X	X	X

## NOTE:

\*1: ACD (Active Center Differential)

\*2: AYC (Active Yaw Center system)

## SCHEDULED MAINTENANCE UNDER SEVERE USAGE CONDITIONS

Maintenance should be carried out according to the following table:

No.	Maintenance item	Service intervals	Mileage in thousands	15	30	45	60	75	90	105	120	135	150
			Kilometers in thousands	24	48	72	96	120	144	168	192	216	240
			Months	15	30	45	60	75	90	105	120	135	150
1	Fuel system (tank, pipe line and connection, and fuel tank filler tube cap)	Check for leaks			X		X		X		X		X
2	Fuel hoses	Check condition			X		X		X		X		X
3	Air cleaner filter	Replace		X	X	X	X	X	X	X	X	X	X
4	Evaporative emission control system (except evaporative emission canister)	Check for leaks and clogging					X				X		
5	Spark plugs	Iridium-tipped type	Replace				X				X		
6	Intake and exhaust valve clearance	Inspect and adjust					X				X		
				If valve noise increases, adjust valve clearance									
7	Drive belts (for the generator and power steering oil pump)	Replace			X		X		X		X		X
8	Exhaust system (connections portion of muffler, muffler pipes and converter heat shields)	Check and service			X		X		X		X		X
9	Engine oil	Turbo	Change	Every 3 months or every 4,800 km (3,000 miles)									
10	Engine oil filter	Turbo	Replace	Every 6 months or every 9,600 km (6,000 miles)									
11	Manual transaxle oil	Change		X	X	X	X	X	X	X	X	X	X
12	Twin clutch sportronic shift transmission oil	Check oil leaks (If necessary, check the oil level)		X	X	X	X	X	X	X	X	X	X
		Change			X		X		X		X		X
13	Transfer oil	Change		X	X	X	X	X	X	X	X	X	X
14	Reserve tank (for ACD*1 and AYC*2)	Check fluid level		X	X	X	X	X	X	X	X	X	X
15	Engine coolant	Change			X		X		X		X		X

No.	Maintenance item	Service intervals	Mileage in thousands	15	30	45	60	75	90	105	120	135	150
			Kilometers in thousands	24	48	72	96	120	144	168	192	216	240
			Months	15	30	45	60	75	90	105	120	135	150
16	Coolant hoses (radiator hose, heater hose)	Inspect		X		X		X		X		X	
		Replace				X					X		
17	Disk brake pads, rotors	Inspect for wear	Every 3 months or every 4,800 km (3,000 miles)										
18	Brake hoses	Check for deterioration or leaks	X	X	X	X	X	X	X	X	X	X	X
19	Ball joint and steering linkage seals	Inspect for grease leaks and damage	X	X	X	X	X	X	X	X	X	X	X
20	Drive shaft boots	Inspect for grease leaks and damage	Every 3 months or every 4,800 km (3,000 miles)										
21	Suspension system	Inspect for looseness and damage	Every 3 months or every 4,800 km (3,000 miles)										
22	Rear axle oil (for differential part)	Change		X		X		X		X		X	
23	Rear axle oil (for torque transfer part)	Change		X		X		X		X		X	
24	Tires	Rotate	Every 3 months or every 4,800 km (3,000 miles)										
25	Air purifier filter	Inspect for clogging	Every 3 months or every 4,800 km (3,000 miles)										
		Replace	Every 6 months or every 9,600 km (6,000 miles)										

**NOTE:**

\*1: ACD (Active Center Differential)

\*2: AYC (Active Yaw Center system)

**Severe usage conditions:**

- Driving on dusty, rough, muddy or salt-spread roads
- Towing or police, taxi or commercial operation
- Extensive idling and/or low speed operation
- Repeated short-trip operation at freezing temperatures (engine not thoroughly warmed up)
- Extended use of brakes while driving
- Driving in sandy areas
- More than 50% operation in heavy city traffic during hot weather above 32° C (90° F)

## MAINTENANCE SERVICE

### 1. FUEL SYSTEM (TANK, PIPE LINE AND CONNECTION, AND FUEL TANK FILLER TUBE CAP) (CHECK FOR LEAKS)

M1001001600367

Check for damage or leakage in the fuel lines and connections.

### 2. FUEL HOSES (CHECK CONDITION)

M1001001700331

1. Inspect the surface of fuel hoses for heat and mechanical damage. Hard and brittle rubber, cracking, tears, cuts, abrasions and excessive swelling indicate deterioration of the rubber.
2. If the fabric casing of the rubber hose is exposed by cracks and abrasions in the fuel system, the hoses should be replaced.

### 3. AIR CLEANER ELEMENT (REPLACE)

M1001001800424

The air cleaner element will become dirty during use, reducing its effectiveness. Replace it with a new one.

Replacement of air cleaner element

1. Unclamp the air cleaner housing.
2. Remove the air cleaner element and install a new one.
3. When clamping the air cleaner housing in place, be sure that the cover is completely closed.

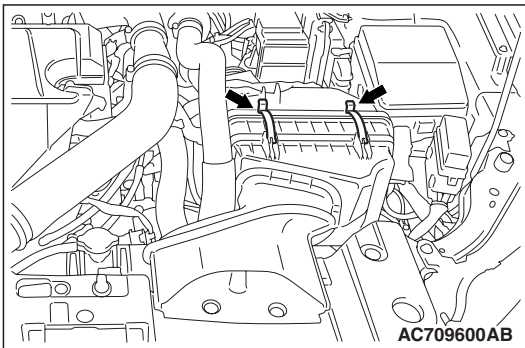

### 4. EVAPORATIVE EMISSION CONTROL SYSTEM (EXCEPT EVAPORATIVE EMISSION CANISTER) (CHECK FOR LEAKS AND CLOGGING)

M1001001900410

If the fuel-vapor vent line is clogged or damaged, fuel vapor will escape into the atmosphere causing excessive emissions. Disconnect the line at both ends, and blow it clean with compressed air. Remove the fuel tank filler tube cap from the filler tube and check to see if there is evidence that the seal makes improper contact to the filler tube.

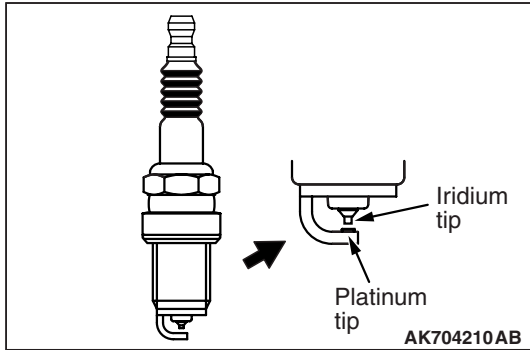

## 5. SPARK PLUGS (REPLACE)

M1001002000476

### ⚠ CAUTION

**Iridium plugs are used. Use care not to damage the iridium tips of the plugs. Do not adjust the spark plug gap.**

1. Spark plugs must spark properly to assure proper engine performance and reduce exhaust emission level. Therefore, they should be replaced periodically with new ones.

Spark plug type

Maker	Identification No.
NGK	ILKR8E6

2. The new plugs should be checked for the proper gap.

**Spark plug gap: 0.5 –0.6 mm (0.020 –0.023 inch)**

3. Install the spark plugs and tighten to  $18 \pm 2$  N·m ( $13 \pm 1$  ft-lb).

## 6. INTAKE AND EXHAUST VALVE CLEARANCE (INSPECT AND ADJUST)

M1001012900180

*NOTE: Perform the valve clearance check and adjustment at the engine cold state.*

1. Remove all of the ignition coils.
2. Remove the cylinder head cover.

### ⚠ CAUTION

**Turn the crankshaft always clockwise.**

3. Turn the crankshaft clockwise, and align the timing mark on the exhaust camshaft sprocket against the upper face of the cylinder head as shown in Figure. Therefore, No.1 cylinder goes to the compression top dead center.

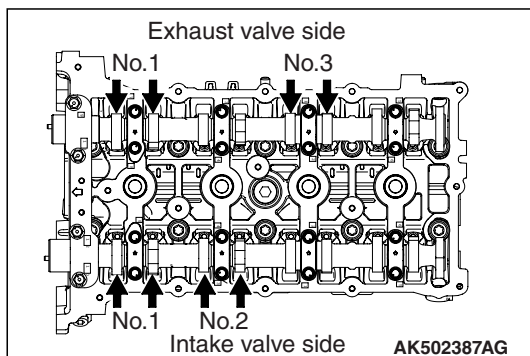
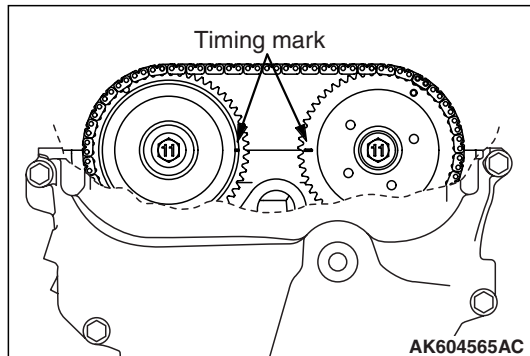

4. Using a thickness gauge, measure the valve clearance with the arrow shown in Figure. If deviated from the standard value, make note for the valve clearance.

**Standard value:**

**Intake valve  $0.20 \pm 0.03$  mm ( $0.008 \pm 0.0012$  inch)**

**Exhaust valve  $0.30 \pm 0.03$  mm ( $0.012 \pm 0.0012$  inch)**



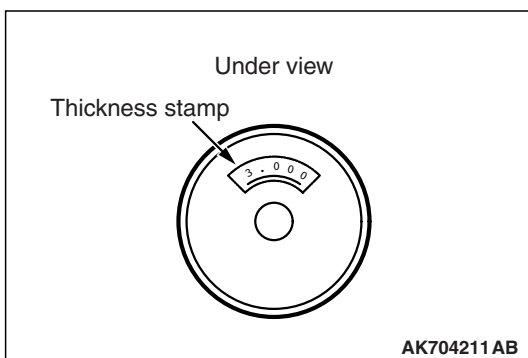
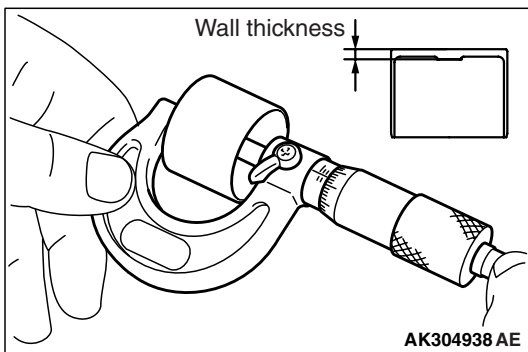
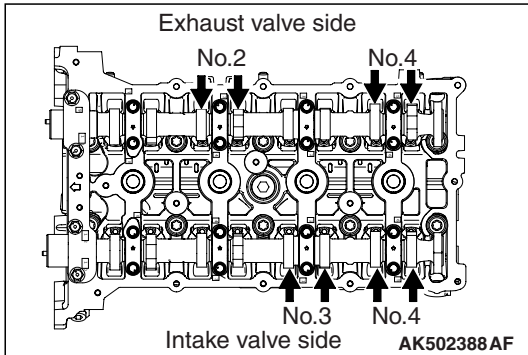
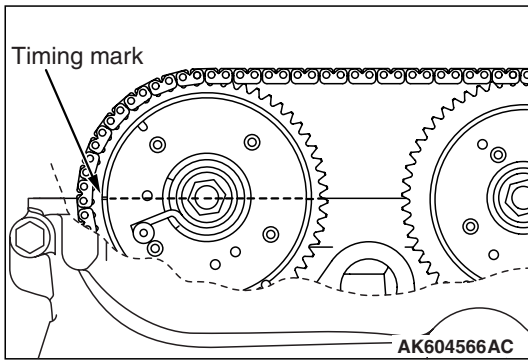

5. Turn the crankshaft clockwise 360 degrees, and put the timing mark on the exhaust camshaft sprocket in position shown in Figure. Therefore, No.4 cylinder goes to the compression top dead center.

6. Check the valve clearance with the arrow shown in Figure. In the same procedure as 4.

7. If the valve clearance is deviated from the standard value, remove the camshaft and the valve tappet. For the camshaft removal, refer to Camshaft Removal and Installation P.11A-25.

8. Using a micrometer, measure the thickness of the removed valve tappet.

9. Calculate the thickness of the newly installed valve tappet through the following equation.

A: thickness of newly installed valve tappet

B: thickness of removed valve tappet

C: measured valve clearance

**Equation**

**Intake valve:  $A = B + [C - 0.20 \text{ mm (0.008 inch)}]$**

**Exhaust valve:  $A = B + [C - 0.30 \text{ mm (0.012 inch)}]$**

*NOTE: The valve tappet ranges 3,000 – 3,690 mm (0.1181 – 0.1453 inch) and has 47 types per 0.015 mm (0.0006 inch). The thickness below a decimal point is stamped on the reverse side of the valve tappet.*

10. Install the valve tappet selected through the procedure 9, and put the camshaft in position. For the camshaft installation, refer to Camshaft Removal and Installation P.11A-25.

11. After installing the timing chain, measure the valve clearance using the procedure 3 to 6. Confirm the clearance is within the standard value.

**CAUTION**

**Completely remove all the old FIPG, which might be remaining among the components.**

12. After completely removing the liquid gasket adhering on the timing chain case, cylinder block and cylinder head, degrease them with white gasoline.

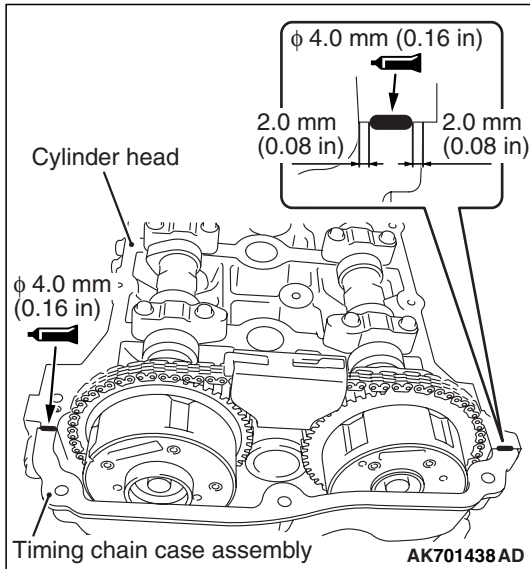

**CAUTION**

The cylinder head cover should be installed within 3 minutes of applying liquid gasket.

13. Apply a 4 mm bead of liquid gasket as illustrated.

**Specified sealant:**

**THREE BOND 1217G or exact equivalent**

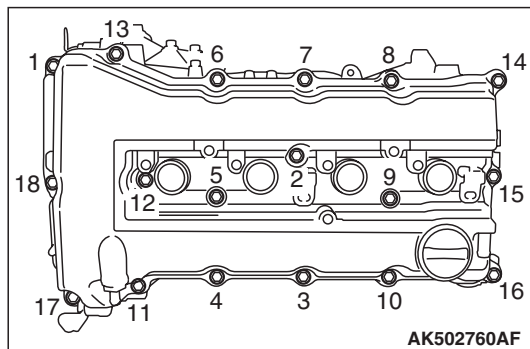

14. Install the cylinder head cover and tighten the tightening bolts using the following procedures.

(1) Temporarily tighten to the following torque in order shown in the illustration.

**Tightening torque: 3.0 ± 1.0 N·m (27 ± 9 in-lb)**

(2) Tighten to the specified torque in order shown in the illustration.

**Specified torque: 5.5 ± 0.5 N·m (49 ± 9 in-lb)**

15. Install the ignition coils.

**7. DRIVE BELT (FOR THE GENERATOR AND POWER STEERING OIL PUMP) (REPLACE)**

M1001002500589

1. Remove the radiator condenser tank. (Refer to GROUP 14 – Radiator P.14-31).

**CAUTION**

**Check the drive belt tension after turning the crankshaft clockwise one turn or more.**

2. Make sure that the indicator mark on the auto-tensioner is within the area marked with A in the illustration.

3. If the mark is out of the area A, replace the drive belt (Refer to P.11A-21).

*NOTE: The drive belt tension check is not necessary as the auto-tensioner is adopted.*

4. Install the radiator condenser tank. (Refer to GROUP 14 – Radiator P.14-31).

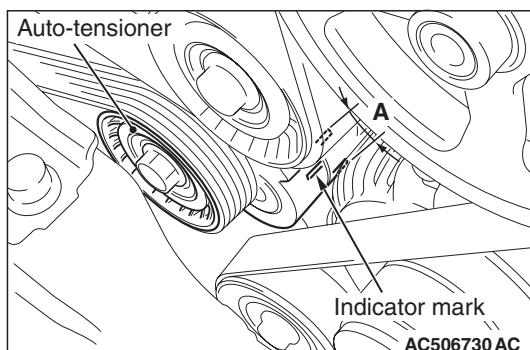

## 8. EXHAUST SYSTEM (CONNECTIONS PORTION OF MUFFLER, MUFFLER PIPES AND CONVERTER HEAT SHIELDS) (CHECK AND SERVICE)

M1001005800459

Check for holes and exhaust gas leaks due to damage, corrosion, etc.

1. Check the joints and connections for looseness and exhaust gas leaks.
2. Check the rubber hangers and brackets for damage.

## 9. ENGINE OIL (CHANGE)

M1001002600661

1. Start the engine and allow it to warm up until the temperature of the coolant reaches 80 –90° C (176 – 194° F).

### **⚠ WARNING**

**Use care as oil could be hot.**

2. Remove the engine oil filler cap.
3. Remove the engine room under cover extension. (Refer to GROUP 51, Under Cover P.51-16)
4. Remove the drain plug to drain oil.
5. Install a new drain plug gasket so that it faces in the direction shown in the illustration, and then tighten the drain plug to the specified torque.

**Tightening torque: 39 ± 5 N· m (29 ± 3 ft-lb)**

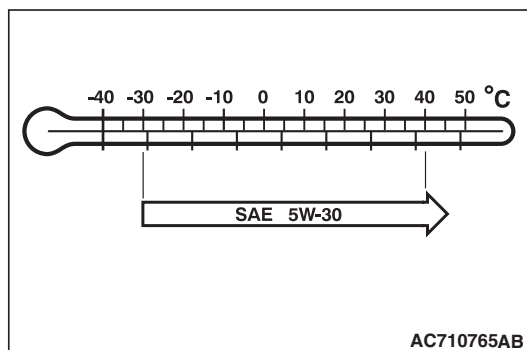
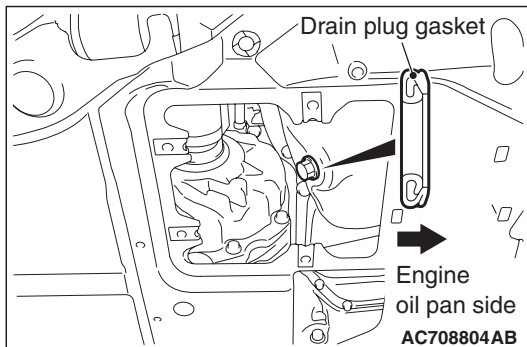

### **⚠ CAUTION**

- Do not use conventional petroleum based motor oil. Using conventional motor oil may cause engine or turbocharger damage.
  - Do not used "blends" of conventional oil and synthetic oil.
  - If engine oil other than 5W-30 is used, the engine may be seized by poor lubrication.
6. Refill the specified quantity of oil.

**Specified Engine Oil: Engine oils displaying ILSAC certification symbol ("Starburst" symbol) or conforming to the API classification SM or higher**

**Total quantity: 5.6 dm<sup>3</sup> (5.9 quarts)**

7. Install the engine oil filler cap.
8. Let the engine run for a few minutes.
9. Stop the engine, and then check the oil level using the oil dipstick after a few minutes.
10. Install the engine room under cover extension. (Refer to GROUP 51, Under Cover P.51-16)

**10. ENGINE OIL FILTER (REPLACE)**

M1001002700594

1. Start the engine and allow it to warm up until the temperature of the coolant reaches 80 –90° C (176 –194° F)

**⚠ WARNING*****Use care as oil could be hot.***

2. Remove the engine oil filler cap.
3. Remove the engine room under cover extension (Refer to GROUP 51, Under Cover P.51-16).
4. Remove the drain plug to drain oil.
5. Use the respective tool in the following table to remove the engine oil filter.

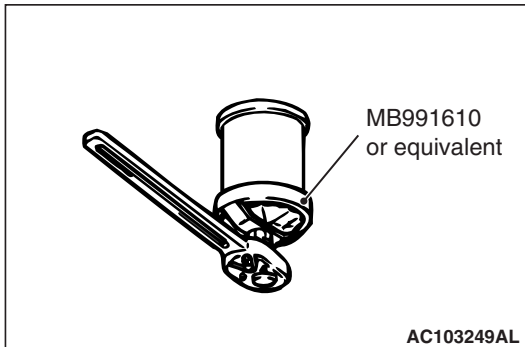

Number	Special tool
MD356000	Oil filter wrench (MB991610) or equivalent

6. Clean the filter bracket side mounting surface and ensure the old O-ring has been removed.
7. Apply a small amount of engine oil to the O-ring of the new oil filter.
8. Screw on the oil filter by hand until it touches the surface of the flange and then tighten it with an oil filter wrench.

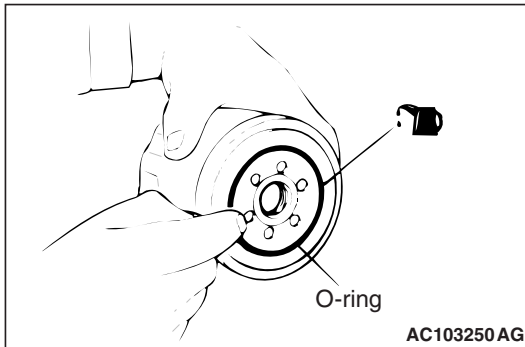

Number	Special tool	Tightening torque
MD356000	MB991610 or equivalent	Approximately 3/4 turn [14 ± 2 N· m (124 ± 17 in-lb)]

9. Install the drain plug and refill engine oil (Refer to P.12-5).
10. Rev the engine a few times, and check to be sure that no engine oil leaks at the oil filter.
11. Install the engine room under cover extension (Refer to GROUP 51, Under Cover P.51-16).

**11. MANUAL TRANSAXLE OIL (CHECK OIL LEVEL AND CONDITION/RCHANGE)**

M1001006100118

**TRANSAXLE OIL LEVEL CHECK**

1. Remove the engine room under cover front B assembly. (Refer to GROUP 51 –Under cover P.51-16.)

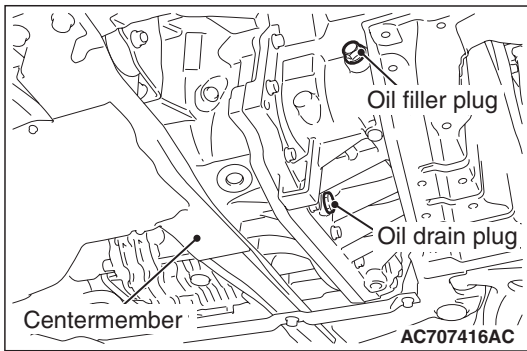

2. Remove the oil filler plug and gasket.

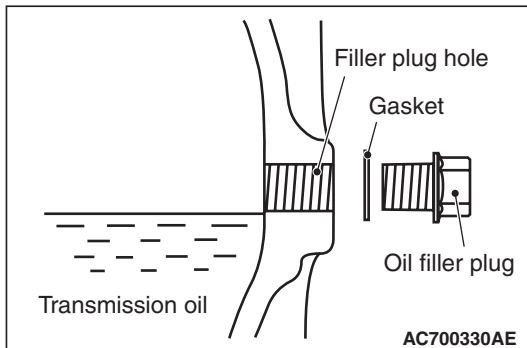

3. Check that the oil level is just below the lower edge of the oil filler plug hole.
4. Check that the oil is not excessively foul and has moderate viscosity.
5. Install the oil filler plug and new gasket, then tighten them to the specified torque.

**Tightening torque: 32 ± 2 N· m (24 ± 1 ft-lb)**

6. Install the engine room under cover front B assembly. (Refer to GROUP 51 –Under cover [P.51-16.](#))

## TRANSAXLE OIL CHANGE

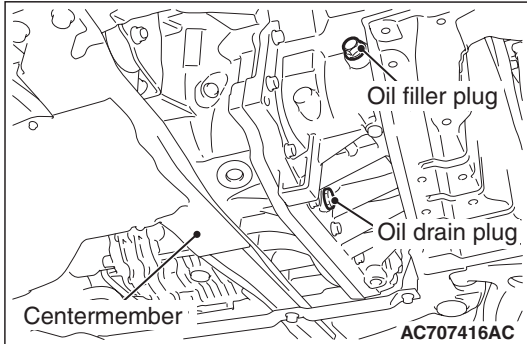

1. Remove the engine room under cover front B assembly. (Refer to GROUP 51 –Under cover [P.51-16.](#))
2. Remove the oil drain plug and gasket to drain the oil.
3. Install the oil drain plug and new gasket, then tighten them to the specified torque.

**Tightening torque: 32 ± 2 N· m (24 ± 2 ft-lb)**

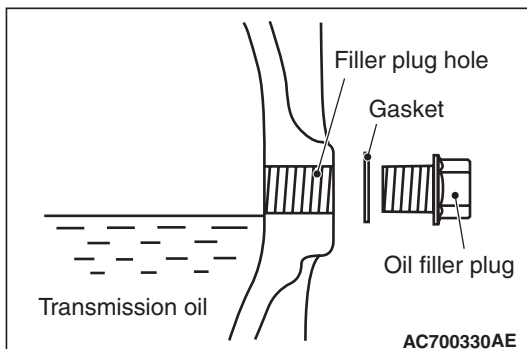

4. Remove the oil filler plug and gasket, then fill the oil up to the lower edge of the oil filler plug.

**Brand name: Mitsubishi genuine Dia-Queen New Multi Gear Oil SAE 75W-80 API GL-3**

**Quantity: 2.5 dm<sup>3</sup> (2.6 quarts)**

5. Install the oil filler plug and new gasket, then tighten them to the specified torque.

**Tightening torque: 32 ± 2 N· m (24 ± 1 ft-lb)**

6. Install the engine room under cover front B assembly. (Refer to GROUP 51 –Under cover [P.51-16.](#))

## 12. TWIN CLUTCH SPORTRONIC SHIFT TRANSMISSION [CHECK OIL LEAKS (IF NECESSARY, CHECK THE OIL LEVEL) /CHANGE]

M1001016600017

### TC-SST OIL LEVEL CHECK

1. After cleaning the outer surface of transaxle, visually check that there is no oil oozing or oil leaking from the transaxle.
2. If an oil oozing or leaking is present, replace the transaxle assembly.

### TC-SST OIL CHANGE

1. Remove the engine compartment under cover front B assembly. (Refer to GROUP 51 –Under Cover P.51-16.)
2. Remove the oil drain plug to drain the oil.  
*NOTE: Because the oil in the oil cooler and oil filter cannot be drained, the amount of drained oil will be approximately 5.5 dm<sup>3</sup>.*
3. Tighten the oil drain plug to the specified torque.  
**Tightening torque: 25 N· m**
4. Remove the air cleaner element, air cleaner intake duct, and air cleaner body. (Refer to GROUP 15 –Air Cleaner P.15-10.)
5. Remove the oil filler plug, then fill the oil.  
**Brand name: Mitsubishi genuine Dia-Queen SSTF-I**  
**Filling amount: Approximately 5.5 dm<sup>3</sup>**
6. Tighten the oil filler plug to the specified torque.  
**Tightening torque: 25 N· m**
7. Install the air cleaner element, air cleaner intake duct, and air cleaner body. (Refer to GROUP 15 –Air Cleaner P.15-10.)
8. Start the engine, then let it idle for 1 to 2 minutes.
9. Move the shift lever to every position, and then move it to the P or N range.
10. Stop the engine, then perform Steps 2 to 5 again.
11. Check the oil level and oil fouling. (Refer to P.22A-116.) If fouling is found, repeat Steps 2 to 5 until the fouling is eliminated.
12. Install the engine compartment under cover front B assembly. (Refer to GROUP 51 –Under Cover P.51-16.)

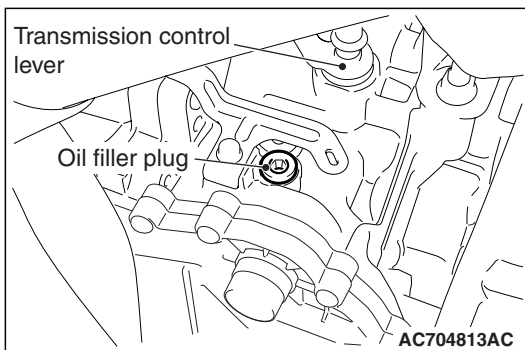
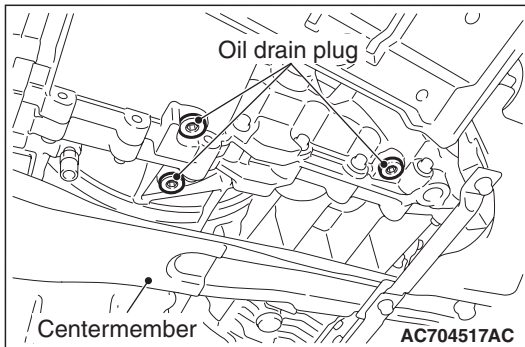

### 13. TRANSFER OIL (CHECK OIL LEVEL/CHANGE)

M1001003000208

#### TRANSFER OIL CHECK

1. Remove the engine room under cover front B assembly.  
(Refer to GROUP 51 –Under cover P.51-16.)
2. Remove the oil filler plug and gasket.

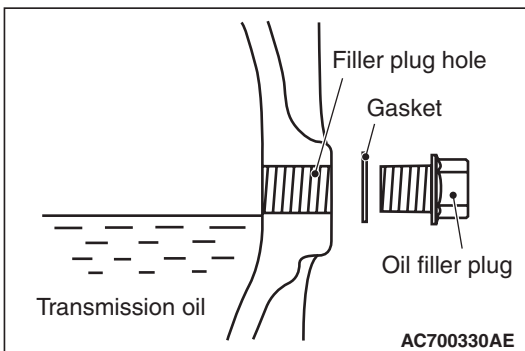
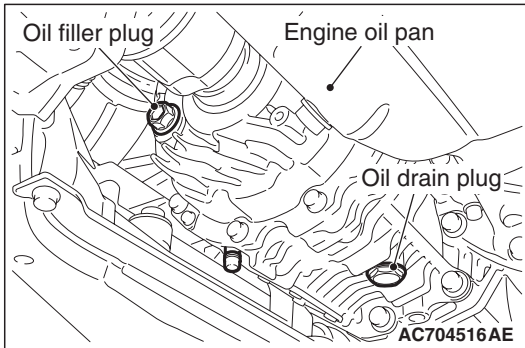

3. Check that the oil level is just below the lower edge of the oil filler plug hole.
4. Check that the oil is not excessively foul and has moderate viscosity.
5. Install the oil filler plug and new gasket, then tighten them to the specified torque.  
**Tightening torque:  $32 \pm 2$  N·m ( $24 \pm 1$  ft-lb)**
6. Install the engine room under cover front B assembly. (Refer to GROUP 51 –Under cover P.51-16.)

#### TRANSFER OIL CHANGE

1. Remove the engine room under cover front B assembly.  
(Refer to GROUP 51 –Under cover P.51-16.)
2. Remove the oil drain plug and gasket to drain the oil.
3. Install the oil drain plug and new gasket, then tighten them to the specified torque.

**Tightening torque:  $32 \pm 2$  N·m ( $24 \pm 1$  ft-lb)**

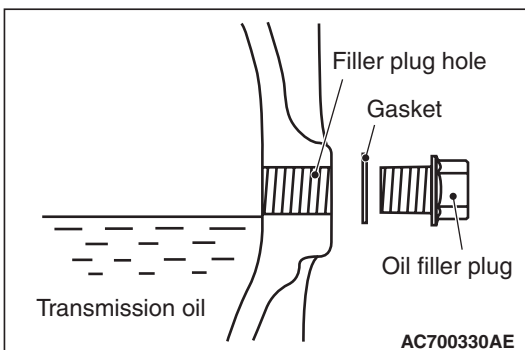
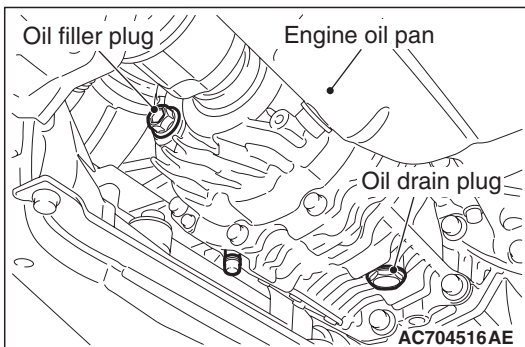

4. Remove the oil filler plug and gasket, then fill the oil up to the lower edge of the oil filler plug hole.

**Brand name: Mitsubishi genuine Dia-Queen LSD Gear Oil**

**Quantity:  $0.9 \text{ dm}^3$  (1.0 quarts)**

5. Install the oil filler plug and new gasket, then tighten them to the specified torque.  
**Tightening torque:  $32 \pm 2$  N·m ( $24 \pm 1$  ft-lb)**
6. Install the engine room under cover front B assembly. (Refer to GROUP 51 –Under cover P.51-16.)

**14. RESERVE TANK FLUID (FOR ACTIVE CENTER DIFFERENTIAL AND ACTIVE YAW CONTROL SYSTEM) (CHECK FLUID LEVEL)**

M1001017500013

**FLUID LEVEL CHECK****<WHEN THE SCAN TOOL IS NOT USED>**

1. Remove the trunk room side trim lid on the right of the trunk room.
2. If the vehicle has been run, leave it for 90 min. or more in an ordinary temperature {10 –30° C (50 –86° F)} to allow the accumulator internal pressure to drop.

*NOTE: If the ambient temperature is 10° C (50° F) or less, allow more time to leave the vehicle to stand idle.*

3. Check that the oil reservoir fluid level is in between MAX and MIN.
4. If the fluid level is not in between MAX and MIN, fill the specified fluid.

**Specified fluid: DIAMOND ATF-SP III**

5. Install the trunk room side trim lid.

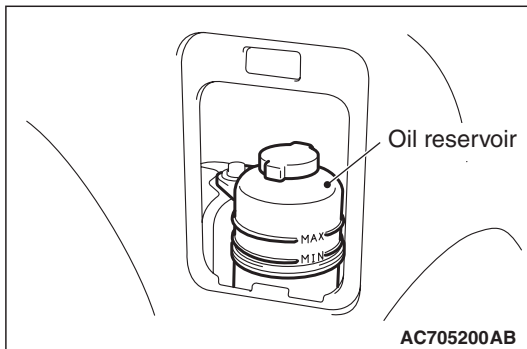
**<WHEN THE SCAN TOOL IS USED>**

1. Remove the trunk room side trim lid on the right of the trunk room.

**⚠ CAUTION**

**Turn the ignition switch to the "LOCK (OFF)" position before connecting or disconnecting the scan tool.**

2. Set the scan tool to the 16-pin data link connector. (Refer to P.27-6.)
3. Turn the ignition switch to the ON position.
4. Using the scan tool, forcibly activate the hydraulic unit (item No. 03) to reduce the pressure inside the accumulator. (Refer to GROUP 22A –Actuator Test Table.)

**NOTE:**

- *With the forced activation (oil level check mode), the hydraulic unit direction valve is operated 20 times to right and left, and then the operation is canceled automatically. Also, using the clear key on the scan tool, the activation can be forcibly canceled.*
- *When the functions are suspended by the fail-safe function, the hydraulic unit cannot be forcibly activated.*



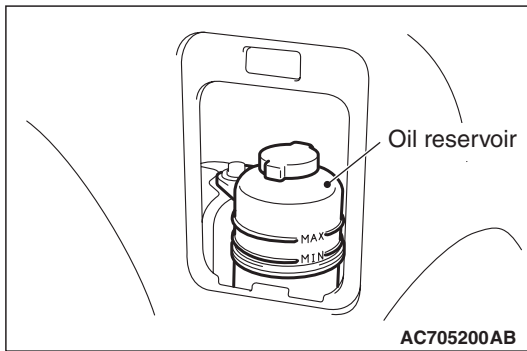

5. Check that the oil reservoir fluid level is in between MAX and MIN.
6. If the fluid level is not in between MAX and MIN, fill the specified fluid.

**Specified fluid: DIAMOND ATF-SP III**

7. Install the trunk room side trim lid.

## 15. ENGINE COOLANT (CHANGE)

M1001003100573

1. Remove the engine room under cover front A (RH). (Refer to GROUP 51, Under Cover [P.51-16](#))

### **⚠ WARNING**

***When removing the radiator cap, use care to avoid contact with hot coolant or steam. Place a shop towel over the cap and turn the cap counterclockwise a little to let the pressure escape through the vinyl tube. After relieving the steam pressure, remove the cap by slowly turning it counterclockwise.***

2. Drain the water from the radiator, heater core and engine after unplugging the radiator drain plug and removing the radiator cap.
3. Remove the engine room under cover front B. (Refer to GROUP 51, Under Cover [P.51-16](#))
4. Remove the air cleaner intake hose. (Refer to GROUP 15, Air Cleaner [P.15-10](#))
5. Remove the turbocharger compressor bracket. (Refer to GROUP 15, Exhaust Manifold and Turbocharger Assembly [P.15-16](#))
6. Disconnect the turbocharger water return hose and drain the coolant in the water jacket.
7. Remove the radiator condenser tank and drain the coolant.
8. Drain the coolant then clean the path of the coolant by injecting water into the radiator from the radiator cap area.
9. Securely tighten the drain plug of the radiator.
10. Reinstall the radiator condenser tank.

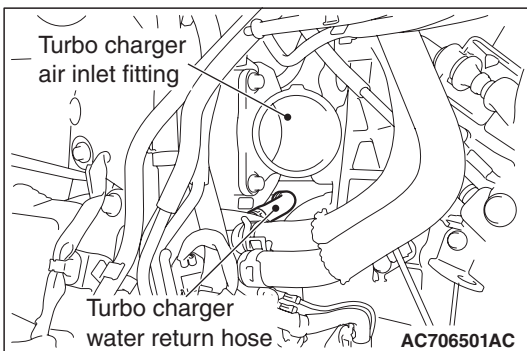

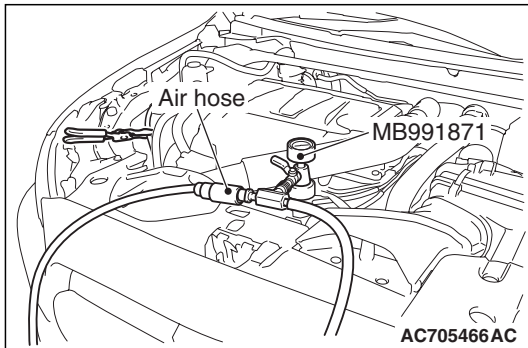

**⚠ CAUTION**

**Do not use alcohol or methanol anti-freeze or any engine coolants mixed with alcohol or methanol anti-freeze. The use of an improper anti-freeze can cause corrosion of the aluminum components.**

11. By referring to the section on coolant, select an appropriate concentration for safe operating temperature within the range of 30 to 60%. Use special tool MB991871 to refill the engine coolant up to the top of the radiator port. A convenient mixture is a 50% water and 50% antifreeze solution [freezing point:  $-31^{\circ}\text{C}$  ( $-23.8^{\circ}\text{F}$ )].

**Recommended antifreeze: Long Life Antifreeze Coolant or an equivalent**

**Quantity:  $7.5\text{ dm}^3$  (7.9 quarts)**

*NOTE: For how to use special tool (MB991871), refer to its manufacturer's instructions.*

12. Tighten the radiator cap securely.
13. Remove the radiator condenser tank cap, and add the engine coolant up to the "FULL" line.
14. Turn the A/C switch to OFF position to start the engine and warm up until the cooling fan operates.

*NOTE: This step opens the thermostat fully.*

15. Rev the engine several times and then stop it. Check that there are no coolant leaks.
16. Remove the radiator cap with the engine cool, and then refill the engine coolant up to the top of the radiator port.
17. Tighten the radiator cap securely.

**⚠ CAUTION**

**Do not overfill the radiator condenser tank.**

18. Remove the radiator condenser tank cap, and add the engine coolant up to the "FULL" line.
19. Install the turbocharger compressor bracket. (Refer to GROUP 15, Exhaust Manifold and Turbocharger Assembly [P.15-16](#))
20. Install the air cleaner intake hose. (Refer to GROUP 15, Air Cleaner [P.15-10](#))
21. Remove the engine room under cover front A and engine room under cover front A (RH). (Refer to GROUP 51, Under Cover [P.51-16](#))

## 16. COOLANT HOSES (RADIATOR HOSE, HEATER HOSE) (INSPECT)

M1001009700175

Inspect the surface of radiator hoses and heater hoses for heat and mechanical damage. Hard and brittle rubber, cracking, tears, cuts, abrasions and excessive swelling indicate deterioration of the rubber.

## 17. DISK BRAKE PADS AND ROTORS (INSPECT FOR WEAR)

M1001003200440

### DISK BRAKE PAD CHECK

#### **⚠ CAUTION**

If there is a significant difference in the thicknesses of the pads on the left and right sides, check moving parts (Refer to [P.35A-21](#) ).

1. Visually check the thickness of brake pad from the inspection hole of the caliper body.

#### Standard value:

9.85 mm (0.39 inch) <Front>

9.0 mm (0.35 inch) <Rear>

#### Limit:

2.0 mm (0.08 inch) <Front>

2.0 mm (0.08 inch) <Rear>

2. When the thickness is lower than the limit value, replace both brake pads (right and left) as a set (Refer to [P.35A-18](#)).

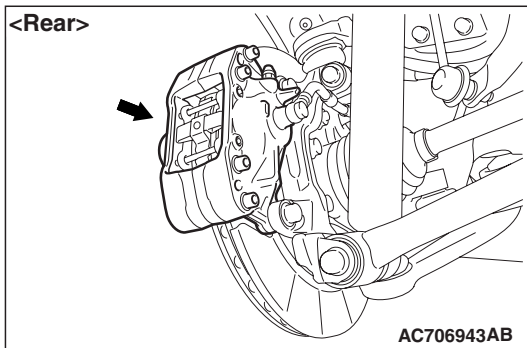
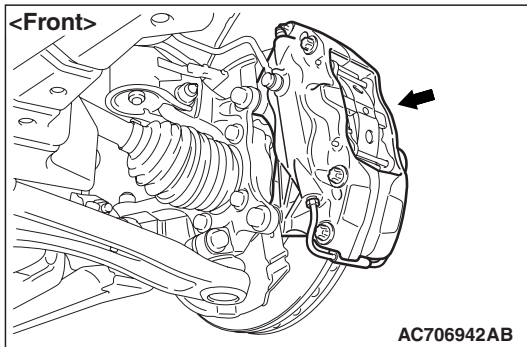

### DISK BRAKE ROTOR CHECK

#### **⚠ CAUTION**

**Disk brakes must be kept within the allowable service values in order to maintain normal brake operation.**

Before turning the brake disk, the following conditions should be checked.

Inspection items	Remarks
Scratches, rust, saturated lining materials and wear	<ul style="list-style-type: none"> <li>• If the vehicle is not driven for a long period of time, sections of the disks that are not in contact with the pads will become rusty, causing noise and shuddering.</li> <li>• If grooves and scratches resulting from excessive disk wear are not removed prior to installing a new pad assembly, there will be inadequate contact between the disk and the lining (pad) until the pads conform to the disk.</li> </ul>
Run-out	Excessive run-out of the disks will increase the pedal depression resistance due to piston kick-back.
Change in thickness (parallelism)	If the thickness of the disk changes, this will cause pedal pulsation, shuddering and surging.

Inspection items	Remarks
Inset or warping (flatness)	Overheating and improper handling while servicing will cause warping or distortion.

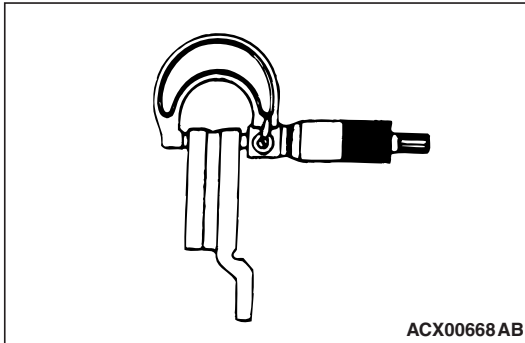

### BRAKE DISK THICKNESS CHECK

- Using a micrometer, measure disk thickness at eight positions, approximately 45 degrees apart and 10 mm (0.4 inch) in from the outer edge of the disk.

**Standard value:**

**32.0 mm (1.26 inch) <Front>**

**22.0 mm (0.87 inch) <Rear>**

**Limit:**

**30.0 mm (1.18 inch) <Front>**

**20.0 mm (0.79 inch) <Rear>**

*NOTE: Thickness variation (at least 8 positions) should not be more than 0.015 mm (0.0006 inch).*

#### **⚠ CAUTION**

- After a new brake disk is installed, always grind the brake disk with on-the-car type brake lathe. If this step is not carried out, the brake disk run-out exceeds the specified value, resulting in judder.
  - When the on-the-car type lathe is used, first install M12 flat washer on the stud bolt in the brake disk side according to the figure, and then install the adapter. If the adapter is installed with M12 flat washer not seated, the brake disk rotor may be deformed, resulting in inaccurate grinding.
  - Grind the brake disk with all wheel nuts diagonally and equally tightened to the specified torque 100 N·m (74 ft-lb). When all numbers of wheel nuts are not used, or the tightening torque is excessive or not equal, the brake disk rotor or drum may be deformed, resulting in judder.
- If the disk thickness is less than the limits, replace it with a new one. If thickness variation exceeds the specification, turn rotor with an on-the-car type brake lathe ("MAD, DL-8700PF" or equivalent). If the calculated final thickness after turning the rotor is less than the standard value, replace the disk.

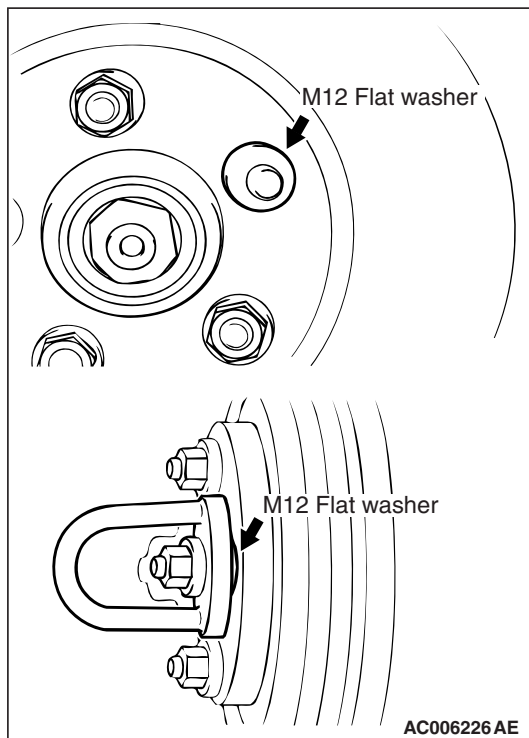

### FRONT BRAKE DISK RUN-OUT CHECK AND CORRECTION

- Remove the brake assembly, and then hold it with wire.
- Temporarily install the disk with the hub nut.

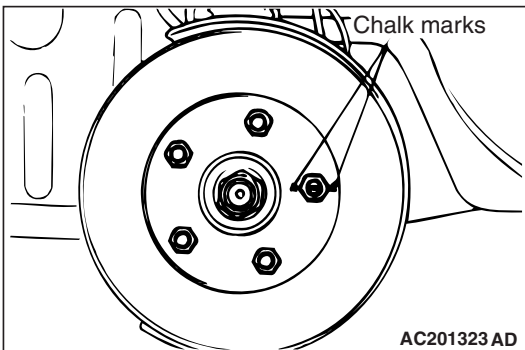
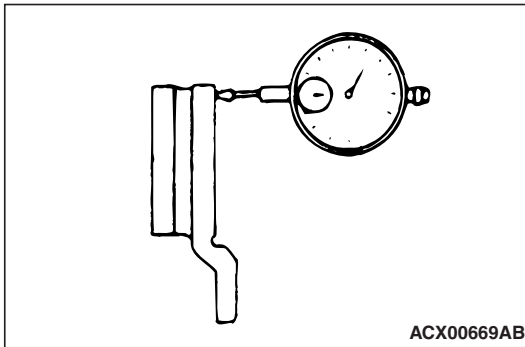

- Place a dial gauge approximately 5 mm (0.2 inch) from the outer circumference of the brake disk, and measure the run-out of the disk.

**Limit:**

**0.06 mm (0.0024 inch) <Front>**

**0.08 mm (0.0032 inch) <Rear>**

- When the brake disk runout exceeds the limit value, correct the brake disk runout according to the following procedure.

- Before removing the brake disk, make marks using a chalk to the stud bolt on the side with the greater runout and to both sides of the stud bolt.
- Check the wheel bearing axial looseness. (Refer to GROUP 26 –On-vehicle Service, Wheel Bearing End Play Check P.26-7 <Front> or GROUP 27 –On-vehicle Service, Wheel Bearing End Play Check P.27-33 <Rear>.)
- When the looseness is within the limit value, install the brake disk after changing the phase between the hub and the brake disk, then check the runout of the brake disk again.

**CAUTION**

- After a new brake disk is installed, always grind the brake disk with on-the-car type brake lathe. If this step is not carried out, the brake disk run-out exceeds the specified value, resulting in judder.
  - When the on-the-car type lathe is used, first install M12 flat washer on the stud bolt in the brake disk side according to the figure, and then install the adapter. If the adapter is installed with M12 flat washer not seated, the brake disk rotor may be deformed, resulting in inaccurate grinding.
  - Grind the brake disk with all wheel nuts diagonally and equally tightened to the specified torque 100 N·m (74 ft-lb). When all numbers of wheel nuts are not used, or the tightening torque is excessive or not equal, the brake disk rotor or drum may be deformed, resulting in judder.
- If the run-out cannot be corrected by changing the phase of the brake disk, replace the brake disk or grind it with the on-the-car type brake lathe ("MAD, DL-8700PF" or equivalent).

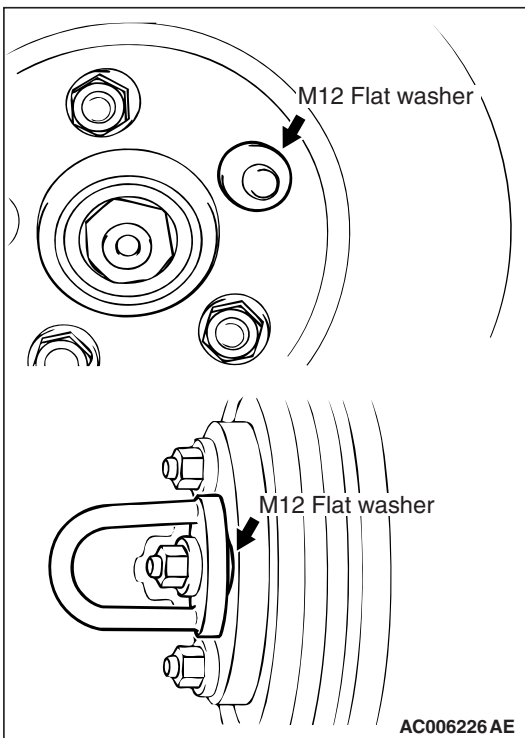

**18. BRAKE HOSES (CHECK FOR  
DETERIORATION OR LEAKS)**

M1001003400488

Inspection of brake hoses should be included in all brake service operations.

The hoses should be checked for:

1. Incorrect length, severe surface cracking, pulling, scuffing or worn spots. (If the fabric casing of the hoses is exposed by cracks or abrasion in the rubber hose cover, the hoses should be replaced. Eventual deterioration of the hose and possible bursting failure may occur).
2. Incorrect installation, twisting or interference with wheel, tire or chassis.

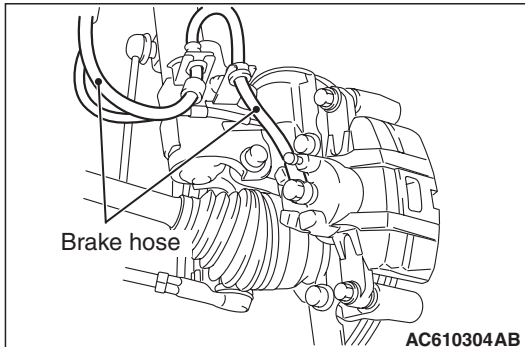
**19. BALL JOINT AND STEERING LINKAGE  
SEALS (INSPECT FOR GREASE LEAKS AND  
DAMAGE)**

M1001003500496

1. These components, which are permanently lubricated at the factory, do not require periodic lubrication. Damaged seals and boots should be replaced to prevent leakage or grease contamination.
2. Inspect the dust cover and boots for proper sealing, leakage and damage, and replace them if defective.

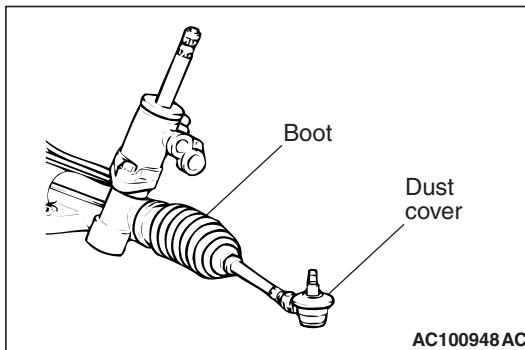
**20. DRIVE SHAFT BOOTS (INSPECT FOR  
GREASE LEAKS AND DAMAGE)**

M1001003600493

1. These components, which are permanently lubricated at the factory, do not require periodic lubrication. Damaged seals and boots should be replaced to prevent leakage or grease contamination.
2. Inspect the dust cover and boots for proper sealing, leakage and damage. Replace them if defective.

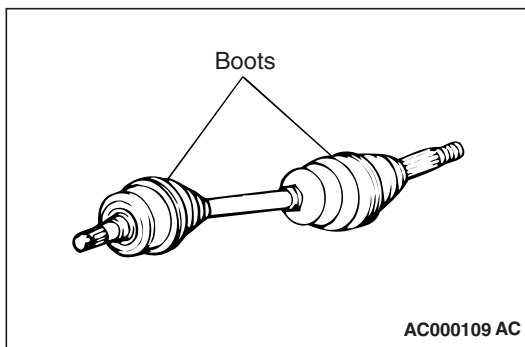
**21. SUSPENSION SYSTEM (INSPECT FOR  
LOOSENESS AND DAMAGE)**

M1001009600219

Visually inspect the front/rear suspension components for deterioration and damage. Re-tighten the front/rear suspension components retaining bolts to specified torque.

## 22. REAR AXLE OIL (FOR DIFFERENTIAL PART) (CHANGE)

M1001007200118

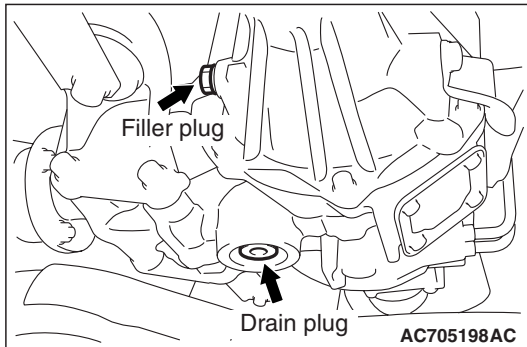

1. Remove the filler plug.
2. Remove the drain plug and drain oil.
3. Install the drain plug, and tighten it to the specified torque.  
**Tightening torque:  $32 \pm 2 \text{ N} \cdot \text{m}$  ( $23 \pm 2 \text{ ft-lb}$ )**
4. Fill the specified gear oil up to the bottom of the filler plug hole.

**Specified gear oil: MITSUBISHI Genuine DIA QUEEN Multi gear oil LS**

**Amount to use:  $0.55 \pm 0.02 \text{ dm}^3$  ( $0.58 \pm 0.02 \text{ qt}$ )**

5. Install the filler plug, and tighten it to the specified torque.  
**Tightening torque:  $49 \pm 10 \text{ N} \cdot \text{m}$  ( $37 \pm 7 \text{ ft-lb}$ )**

## 23. REAR AXLE OIL (FOR TORQUE TRANSFER MECHANISM PART) (CHANGE)

M1001007500164

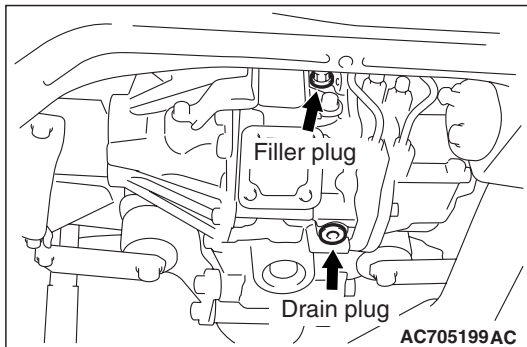

1. Remove the filler plug.
2. Remove the drain plug and drain oil.
3. Install the drain plug, and tighten it to the specified torque.  
**Tightening torque:  $32 \pm 2 \text{ N} \cdot \text{m}$  ( $23 \pm 2 \text{ ft-lb}$ )**
4. Fill the specified gear oil up to the bottom of the filler plug hole.

**Specified gear oil: DIAMOND ATF-SP III**

**Amount to use:  $0.55 - 0.60 \text{ dm}^3$  ( $0.58 - 0.63 \text{ qt}$ )**

5. Install the filler plug, and tighten it to the specified torque.  
**Tightening torque:  $49 \pm 10 \text{ N} \cdot \text{m}$  ( $37 \pm 7 \text{ ft-lb}$ )**

## 24. TIRES (ROTATE)

M1001008900529

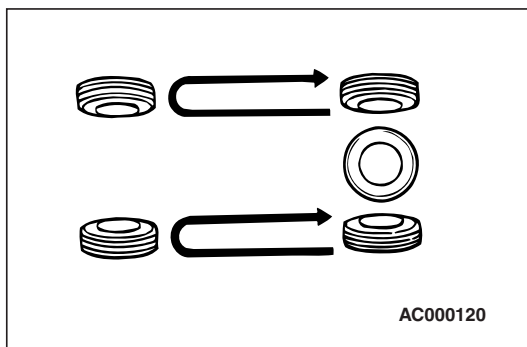

Rotate tires regularly to equalize tire wear and help extend tire life. Recommended tire rotation is every 12,000 km (7,500 miles).

Timing for the rotation may vary according to vehicle condition, road surface conditions, and individual driver's habits.

When rotating tires, check for uneven wear, damage, and wheel alignment. Abnormal wear is usually caused by incorrect tire pressure, improper wheel alignment, out-of balance wheels, or severe braking.

The first rotation is the most important, to achieve more uniform wear for all tires on the vehicle.

**25. AIR PURIFIER FILTER (REPLACE)**

M1001009000143

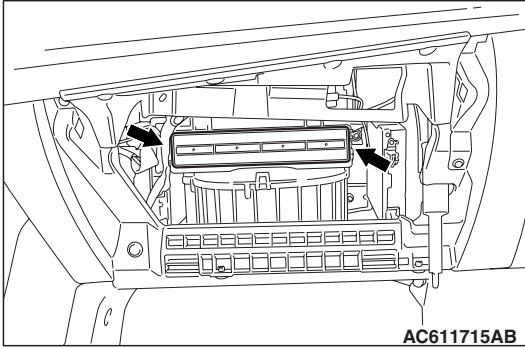

1. Remove the glove box (Refer to GROUP 52A –glove box, P.52A-6).
2. Loosen the two lugs as shown to replace the clean air filter.
3. Install the glove box.

**MAIN SEALANT AND ADHESIVE TABLE**

M1001003800516

Application		3M™/three bond No.	Loctite®/ permatex® No.
ENGINE AND DRIVETRAIN	Between rocker cover, cylinder head and timing chain case.	Three bond 1217G (Mitsubishi Genuine Part No.1000A923), Three bond 1227D (Mitsubishi Genuine Part No.MZ100792)	-
	Between cylinder head gasket. Between timing chain case.	Three bond 1217G (Mitsubishi Genuine Part No.1000A923)	-
	Between oil pan	Three bond 1217G (Mitsubishi Genuine Part No.1000A923), Three bond 1227D (Mitsubishi Genuine Part No.MZ100792), Three bond 1207F (Mitsubishi Genuine Part No.MD970389)	Loctite®5971, Loctite®5900, Loctite®5970
	Between engine oil pressure switch	Three bond 1215, Three bond 1212D	-
	Between engine coolant temperature switch	Three bond 1324	Loctite®262
WEATHERSTRIPPING FOR GLASS	Between tempered glass, body flanges, and weatherstrip	3M™ AAD Part No. 8509 Auto Bedding and Glazing Compound or 3M™ AAD Part No. 8633 Windo-weld Resealant	-
WEATHERSTRIPPING FOR GLASS	Between laminated glass and weatherstrip	3M™ AAD Part No. 8633	-



**GENERAL  
MAIN SEALANT AND ADHESIVE TABLE**

**00-81**

<b>Application</b>		<b>3M™/three bond No.</b>	<b>Loctite®/ permatex® No.</b>
INTERIORS	Adhesive of vinyl chloride cloth	3M™ AAD Part No. 8088 General Trim Adhesive or 3M™ AAD Part No. 8064 Vinyl Trim Adhesive	Permatex® Vinyl Repair Kit No.81786
	Adhesion of door weatherstrip	3M™ AAD Part No. 8001 (yellow) or 3M™ AAD Part No. 8008 (black) Super Weatherstrip Adhesive or 3M™ AAD Part No. 8011 Black Weatherstrip Adhesive	Permatex® Super Black Weatherstrip Adhesive No.82, 81850
	Sealing of various grommets and packing	3M™ AAD Part No. 8509 or 3M™ AAD Part No. 8678	-
	Adhesion of headliners and various interior decorative materials	3M™ AAD Part No. 8088 General Trim Adhesive or 3M™ AAD Part No. 8090 Super Trim Adhesive	Permatex® Spray Adhesive No.82019
BODY SEALANTS	Sealing of sheet metal joints, drip rail, floor, side panels, trunk, front panel, tail gate hinge	3M™ AAD Part No. 8531 Heavy Drip-Check Sealer (gray) or 3M™ AAD Part No. 8302 Ultrapro Autobody Sealant (clear) or 3M™ AAD Part No. 8361 Urethane A/B Sealant (gray or white)	-
	Miscellaneous body sealants (original mounted w/adhesive tape) <ul style="list-style-type: none"> <li>• Waterproof door film</li> <li>• Fender panel</li> <li>• Splash shield</li> <li>• Mud guard</li> <li>• Rear combination lamp</li> </ul>	3M™ AAD Part No. 8633 Windo-weld Resealant	-
	Fuel Tank and Pad	3M™ AAD Part No. 8088 General Trim Adhesive or 3M™ AAD Part No. 8090 Super Trim Adhesive	Permatex® Spray Adhesive No.82019

**GENERAL  
MAIN SEALANT AND ADHESIVE TABLE**

Application		3M™/three bond No.	Loctite®/ permatex® No.
CHASSIS SEALANT	Sealant of various flange faces and threaded parts. Packing of fuel gauge unit	3M™ AAD Part No. 8730 High Strength Red Threadlock or 3M™ AAD Part No. 8731 Medium Strength Blue Threadlocker	Loctite®272 High Strength and High Temperature 27200
	Sealing of various threaded parts, dust covers. Differential carrier packing, dust covers and ball joint and linkage. Packing and shims of steering box, sealing of rack support cover and top cover of steering box housing, seal of junction face of knuckle arm flange	3M™ AAD Part No. 8672 Ultrapro High Temp. Silicone Gasket or 3M™ AAD Part No. 8679 (black) or 3M™ AAD Part No. 8678 (black) Press-In-Place Silicone gasket strips 3M™ AAD Part No. 8661 or 3M™ AAD Part No. 8663 Super Silicone sealant	Permatex® The Right Stuff No.25223
QUICK FIX ADHESIVE	-	3M™ AAD Part No. 8155 Quick Fix Adhesive	Loctite®Quicktite Super Glue 21309
ANAEROBIC STRONG SEALING AGENT	Fixing of various threads, bolts, screws. Fixing of differential drive gear bolt, Connecting of tilt steering bolt. Fan, pulley, gear Sealing of small gaps and flange faces	3M™ AAD Part No. 8730 High Strength Threadlocker or 3M™ AAD Part No. 8731 Medium Strength Threadlocker	Loctite®271, High-Strength Threadlocker 27100 or 27200
UNDER COATING AGENT	-	3M™ AAD Part No. 8883 Rubberized Undercoating Aerosol or 3M™ AAD Part No. 8864 Body Schutz Undercoating (qt)	Permatex® Heavy-Duty Undercoating 81833