

GROUP 26

FRONT AXLE

CONTENTS

GENERAL INFORMATION	26-2	ON-VEHICLE SERVICE	26-7
GENERAL SPECIFICATIONS	26-3	WHEEL BEARING END PLAY CHECK ...	26-7
SERVICE SPECIFICATIONS	26-4	HUB BOLT REPLACEMENT	26-8
LUBRICANTS	26-4	FRONT AXLE HUB ASSEMBLY	26-9
FRONT AXLE DIAGNOSIS	26-4	REMOVAL AND INSTALLATION	26-9
TROUBLESHOOTING STRATEGY	26-4	INSPECTION	26-13
SYMPTOM CHART	26-4	DRIVESHAFT ASSEMBLY	26-15
SYMPTOM PROCEDURES	26-5	REMOVAL AND INSTALLATION	26-15
SPECIAL TOOLS	26-6	DISASSEMBLY AND ASSEMBLY	26-20
		EBJ BOOT REPLACEMENT	26-23

GENERAL INFORMATION

M1261000100994

For the front axle, the unit bearing (double row angular contact ball bearing) in which the hub and ball bearing are incorporated has been adopted for the front wheel bearing, and the EBJ-ETJ type constant velocity joint for the front driveshaft.

There are the following features.

- The lightweight front driveshaft and compact EBJ-ETJ type constant velocity joint have been equipped.
- Due to the use of the output shaft, the right and left driveshafts have been approximately the same in length, reducing noise, vibration, and torque steer.
- The front driveshaft spline diameter on the wheel-side and differential-side has been increased, improving torsional strength.

- The ABS magnetic encoder for wheel speed detection has been integrated into the front wheel bearing, and the protector cover of magnetic encoder for wheel speed detection has been equipped to the driveshaft.
- The lead-free grease has been adopted for the constant velocity joint.
- Hexavalent chromium has been eliminated from the dust cover material and protector cover of magnetic encoder for wheel speed detection.

NOTE:

EBJ (High Efficiency Compact Birfield Joint): the lighter and smaller constant velocity joint compared with the conventional BJ has been achieved by adopting the eight small balls.

ETJ (High Efficiency Compact Tripod Joint): The lighter and smaller constant velocity joint compared with the conventional TJ has been installed.

CONSTRUCTION DIAGRAM

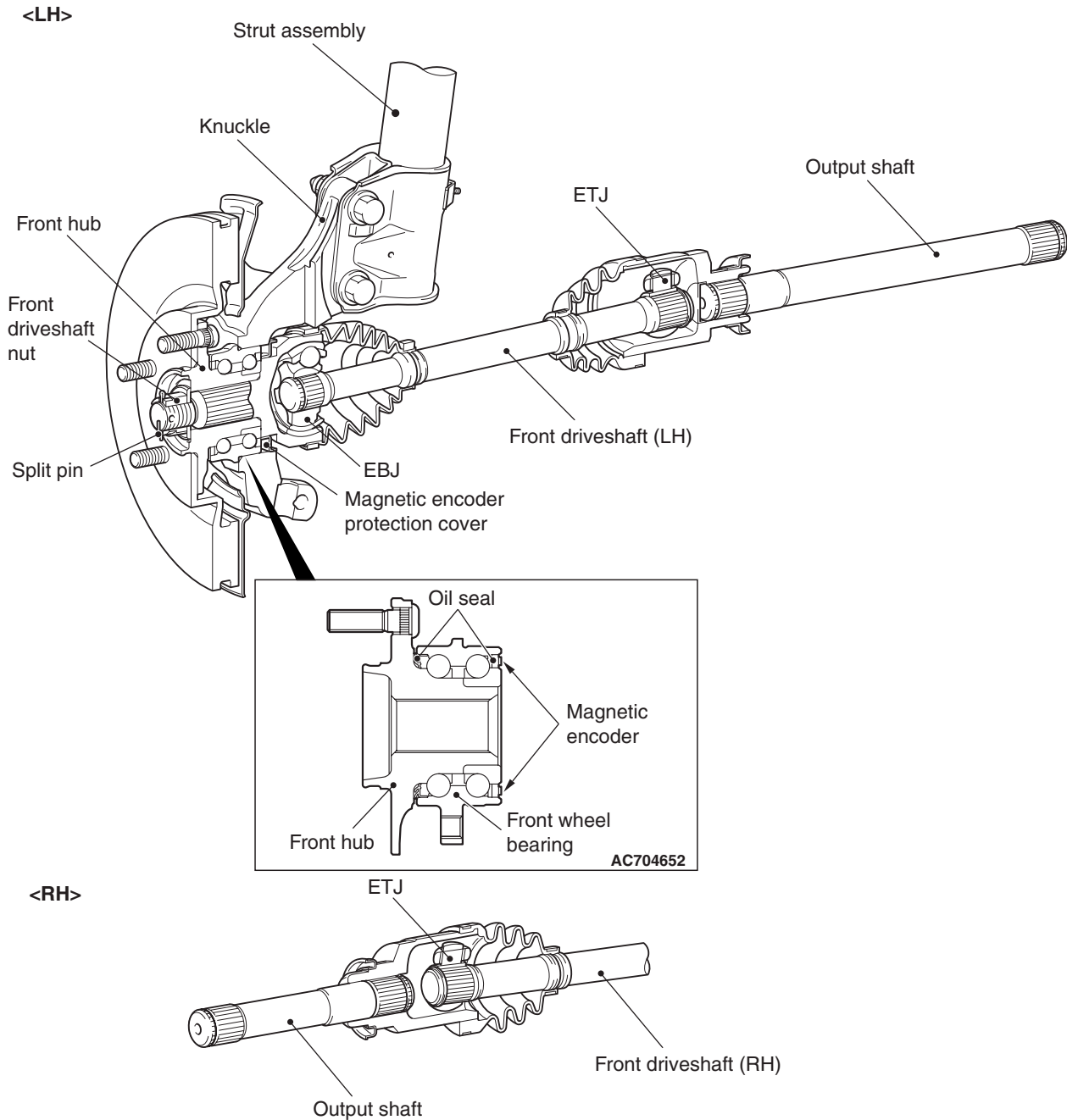

AC704636AB

GENERAL SPECIFICATIONS

M1261000200418

Item		Specification	
Front wheel bearing	Type	Unit bearing (double-row angular contact ball bearing)	
Front driveshaft	Joint type	Outer	High efficiency compact Birfield joint
		Inner	High efficiency compact tripod joint

SERVICE SPECIFICATIONS

M1261000301054

Item		Standard value	Limit
Wheel bearing end play mm (in)		–	0.05 (0.002)
Wheel bearing rotation starting torque N· m(in-lb)		–	1.4 (12.39)
Setting of ETJ boot length mm (in)		80 ± 3 (3.14 ± 0.12)	–
Opening dimension of the special tool (MB991561) mm (in)	When the EBJ boot band (small) is crimped	2.9 (0.11)	–
	When the EBJ boot band (large) is crimped	3.2 (0.13)	–
Crimped width of the EBJ boot band mm (in)		2.4 – 2.8 (0.10 – 0.11)	–

LUBRICANTS

M1261000401147

Item	Specified lubricant	Quantity
ETJ	Repair kit grease	120 ± 10 g (4.2 ± 0.3 oz)
EBJ	Repair kit grease	105 ± 10 g (3.7 ± 0.3 oz)

FRONT AXLE DIAGNOSIS**TROUBLESHOOTING STRATEGY**

Use these steps to plan your diagnostic strategy. If you follow them carefully, you will be sure that you have exhausted most of the possible ways to find a front axle fault.

1. Gather information from the customer.

2. Verify that the condition described by the customer exists.
3. Find the malfunction by following the Symptom Chart.
4. Verify malfunction is eliminated.

M1261005600251

SYMPTOM CHART

M1261005700311

Symptom	Inspection procedure	Reference page
Driveshaft	Noise during wheel rotation	1 P.26-5
	Noise due to excessive play of wheel in turning direction	2 P.26-6

SYMPTOM PROCEDURES

INSPECTION PROCEDURE 1: Noise during Wheel Rotation

DIAGNOSIS

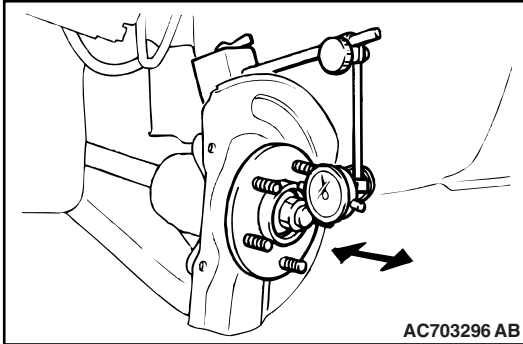

STEP 1. Check the wheel bearing end play.

- (1) Remove the caliper assembly and suspend it with a wire.
- (2) Remove the brake disc from the front hub.
- (3) Attach a dial gauge as shown in the illustration, and then measure the end play while moving the hub in the axial direction.

Limit: 0.05 mm (0.002 inch)

Q: Is the wheel bearing end play within the limit?

YES : Go to step 2.

NO : Replace the part, then go to Step 5.

STEP 2. Check the driveshaft and inner shaft for bending.

Q: Is the driveshaft and inner shaft bent?

YES : Go to step 3.

NO : Replace the part. Then go to Step 5.

STEP 3. Check the center bearing for wear.

Q: Is the center bearing worn?

YES : Replace the bearing. Then go to Step 5.

NO : Go to step 4.

STEP 4. Check the driveshaft assembly for wear or damage.

Q: Is the driveshaft assembly worn or damaged?

YES : Replace the driveshaft assembly. Then go to Step 5.

NO : There is no action to be taken.

STEP 5. Retest the system.

Q: Is the abnormal noise eliminated?

YES : The procedure is complete.

NO : Repeat from Step 1.

INSPECTION PROCEDURE 2: Noise Due to Excessive Play of Wheel in Turning Direction

DIAGNOSIS

STEP 1. Check for play in the output shaft and side gear serration, the driveshaft and side gear serration, or the driveshaft and front hub serration.

Q: Is the play found?

YES : Replace the part. Then go to Step 2.

NO : The procedure is complete.

STEP 2. Retest the system.





Q: Is the abnormal noise eliminated?

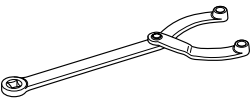
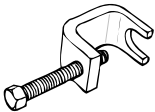

YES : The procedure is complete.

NO : Repeat from Step 1.

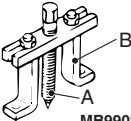
SPECIAL TOOLS

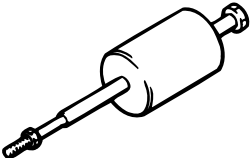
M1261000601260

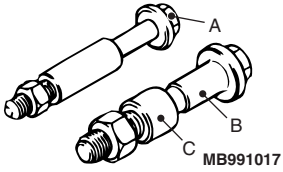
Tool	Tool number and name	Supersession	Application
 B990767	MB990767 Front hub and flange yoke holder	MB990767-01	Fixing of the hub
 MB991618	MB991618 Hub bolt remover	General service tool	Removal of the hub bolt
 MB991897	MB991897 or MB992011 Ball joint remover	MB991113-01, MB990635-01 or General service tool	Ball joint disconnection <i>NOTE: Steering linkage puller (MB990635 or MB991113) is also used to disconnect knuckle and tie rod end ball joint.</i>
 MB990241AD	MB990241 Axle shaft puller A: MB990242 Puller shaft B: MB990244 Puller bar	MB990241-01 or General service tool	<ul style="list-style-type: none"> Removal of the driveshaft Removal of hub assembly
 MB991354	MB991354 Puller body	General service tool	
	MB991721 Slide hammer	—	Removal of the output shaft

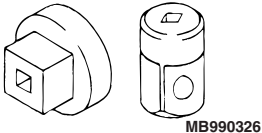
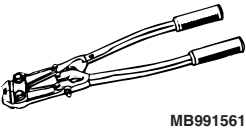
Tool	Tool number and name	Supersession	Application
	<p>A: MB991017 B: MB990998 C: MB991000 A, B: Front hub remover and installer C: Spacer</p>	<p>MB990998-01</p>	<ul style="list-style-type: none"> Provisional holding of the wheel bearing Measurement of hub starting torque Measurement of wheel bearing end play <p><i>NOTE: MB991000, which belongs to MB990998, should be used as a spacer.</i></p>
	<p>MB990685 Torque wrench</p>	<p>General service tool</p>	<p>Measurement of hub starting torque</p>
	<p>MB990326 Preload socket</p>	<p>General service tool</p>	
	<p>MB991561 Boot band crimping tool</p>	<p>MB991561</p>	<p>EBJ boot (resin boot) band installation</p>

ON-VEHICLE SERVICE

WHEEL BEARING END PLAY CHECK

M1261001100373

1. Remove the front caliper assembly and front disk brake, and retain the front caliper assembly with a wire and the like to prevent from falling (Refer to P.26-9).
2. Set a dial gauge as shown in the figure. Move the hub in the axial direction and measure the end play.
Limit: 0.05 mm (0.002 inch)
3. After checking, install the front brake disk and the front caliper assembly (Refer to P.26-9).

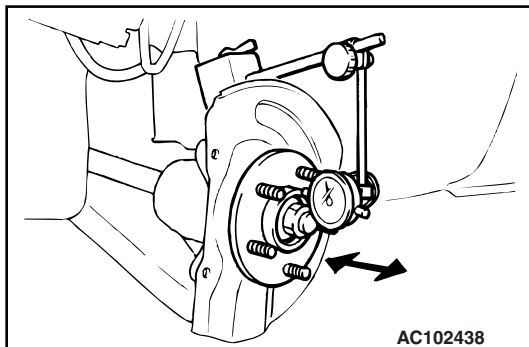

HUB BOLT REPLACEMENT

M1261001000558

Required Special Tools:

- MB990767: Front Hub and Flange Yoke Holder
- MB991618: Hub Bolt Remover

1. Remove the front caliper assembly and front disk brake, and retain the front caliper assembly with a wire and the like to prevent from falling (Refer to [P.26-9](#)).
2. Use special tool MB991618 to remove the hub bolts.

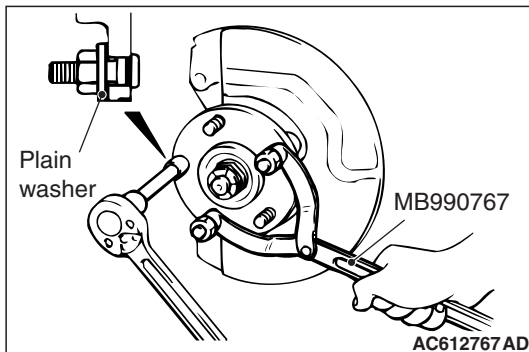
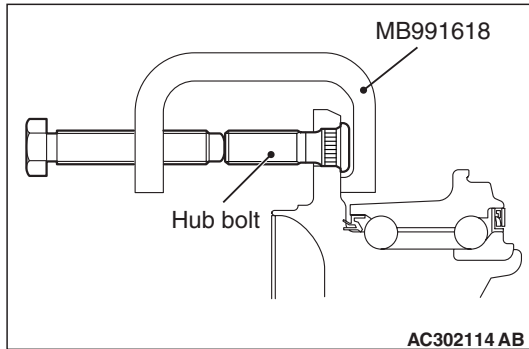

3. Install the plain washer to the new hub bolt, and install the bolt with a nut while holding the hub with special tool MB990767.
4. Install the front brake disk and the front caliper assembly (Refer to [P.26-9](#)).

FRONT AXLE HUB ASSEMBLY

REMOVAL AND INSTALLATION

M1261001701356

CAUTION

- The magnetic encoder collects metallic particles easily, because it is magnetized. Make sure that the magnetic encoder should not collect metallic particles. Check that there is not any trouble prior to reassembling it.
- When removing and installing the front wheel hub assembly, make sure that the magnetic encoder (integrated with the inner oil seal) does not contact with surrounding parts to avoid damage.
- When removing and installing the front wheel speed sensor, make sure that the sensor head at the end does not contact with surrounding parts to avoid damage.
- During maintenance, take care not to contact the parts or tools to the caliper because the paint of caliper will be scratched. And if there is brake fluid on the caliper, wipe off quickly.
- The parts indicated by * are the bolt and nuts with friction coefficient stabilizer. In removal, ensure there is no damage, clean dust and soiling from the bearing and thread surfaces, and tighten them to the specified torque.

Post-installation operation

- Using your fingers, press the Ball Joint Dust Cover to check for a crack or damage.

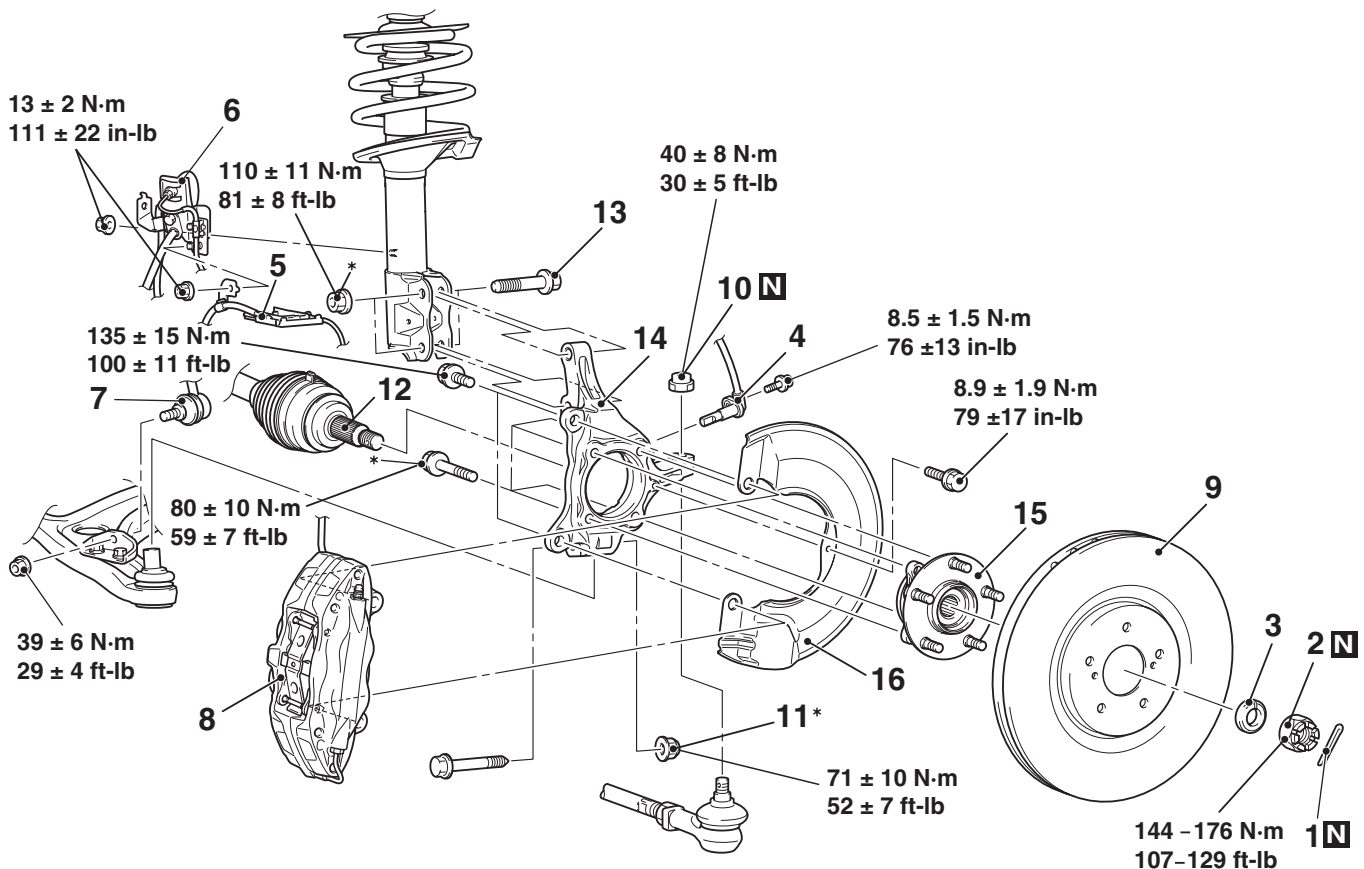

AC709834 AC

Removal steps

- <<A>> >>B<<
>>B<<
1. Cotter pin
 2. Front driveshaft nut
 3. Washer
 4. Front wheel speed sensor

Removal steps (Continued)

5. Front wheel speed sensor harness clip
6. Brake hose bracket

TSB Revision

Removal steps (Continued)

7. Front stabilizer link and lower arm connection
- <> 8. Front caliper assembly
- <<C>> 9. Front brake disk
- <<D>> 10. Self locking nut (tie-rod end connection)
11. Nut (lower arm ball joint connection)
- <<E>> 12. Front hub assembly and front driveshaft assembly connection
- >>A<< 13. Knuckle and strut assembly connection bolt
14. Knuckle
15. Front hub assembly
16. Dust shield

Required Special Tools:

- MB990242: Puller Shaft
- MB990244: Puller Bar
- MB990767: Front Hub and Flange Yoke Holder
- MB991354: Puller Body
- MB991897 or MB992011: Ball Joint Remover

REMOVAL SERVICE POINTS**<<A>> FRONT DRIVESHAFT NUT REMOVAL****⚠ CAUTION**

Do not apply the vehicle weight on the front wheel hub assembly with the driveshaft nut loosened. Otherwise, the wheel bearing may be broken.

Use special tool MB990767 to counter the hub as shown in the figure to remove the front driveshaft nut.

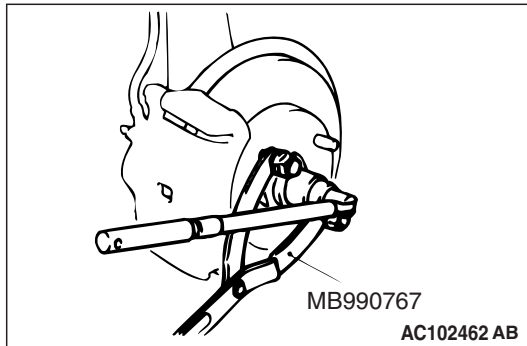
**<> FRONT CALIPER ASSEMBLY REMOVAL**

1. Remove the front caliper assembly with brake hose.
2. Retain the removed front caliper assembly with a wire and the like in a place not to disturb the front hub assembly and knuckle removal.

<<C>> FRONT BRAKE DISK REMOVAL

If the front brake disk removal is difficult, install bolts (M8 x 1.25) shown in the figure, and tighten them evenly and gradually to remove the front brake disk.

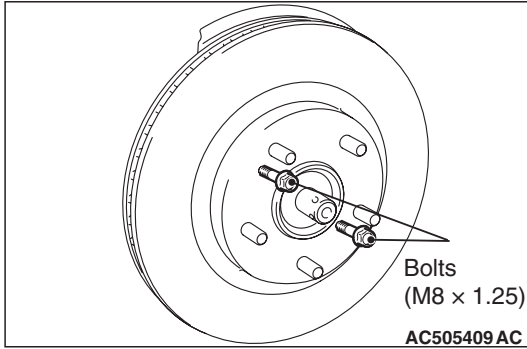

<<D>> SELF-LOCKING NUT (TIE-ROD END CONNECTION) REMOVAL

⚠ CAUTION

- Loosen the self-locking nut (tie-rod end connection) from the ball joint, but do not remove here. Use the special tool.
- To prevent the special tool from dropping off, suspend it with a rope.
- If the dust cover is damaged during operation, replace the tie-rod end. (Refer to GROUP 37 –Power Steering Gear and Linkage Disassembly and Reassembly P.37-36.)

1. Install special tool MB991897 or MB992011 as shown in the figure.

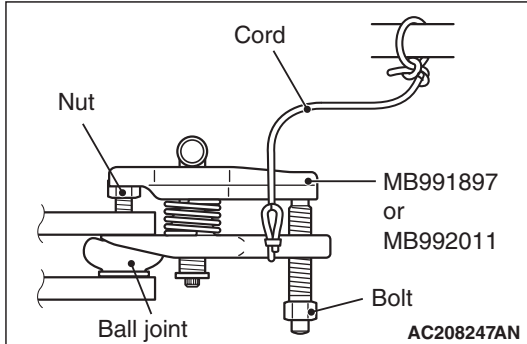

2. Turn the bolt and knob to make the special tool jaws parallel, then hand-tighten the bolt. After tightening, check that the jaws are still parallel.

NOTE: To adjust the special tool jaws to be parallel, set the orientation of the knob as shown in the figure.

3. Tighten the bolt with a wrench to disconnect the tie rod end.

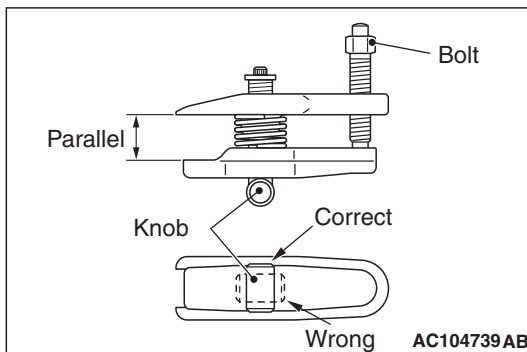

<<E>> FRONT HUB ASSEMBLY AND FRONT DRIVESHAFT ASSEMBLY DISCONNECTION

⚠ CAUTION

- The magnetic encoder collects metallic particles easily, because it is magnetized. Make sure that the magnetic encoder does not collect metallic particles.
- When removing the front driveshaft, make sure that it does not contact with the magnetic encoder (integrated with the inner oil seal) to avoid damage.

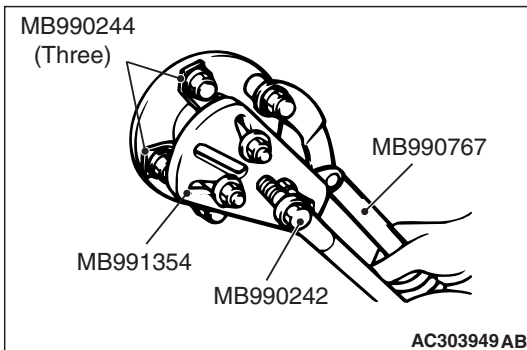
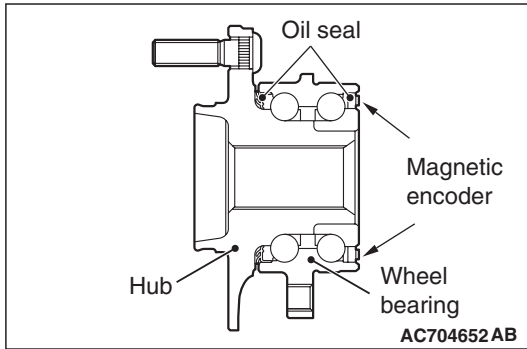

If the front driveshaft and front hub are seized, use special tools MB990242 and MB990244, MB991354 and MB990767 to push the front driveshaft assembly out from the front hub.

INSTALLATION SERVICE POINTS

>>A<< KNUCKLE AND STRUT ASSEMBLY CONNECTION BOLT INSTALLATION

Locate the knuckle and strut assembly upper connection bolt's marking position as shown in the figure and tighten it.

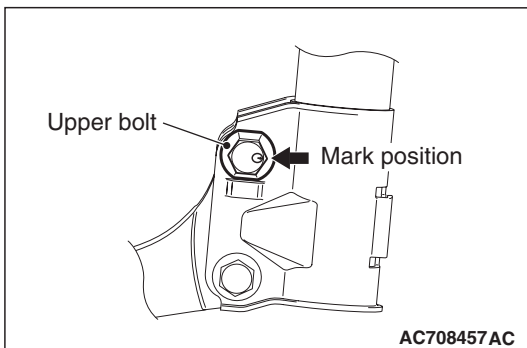

>>B<< WASHER/FRONT DRIVESHAFT NUT INSTALLATION

⚠ CAUTION

- The magnetic encoder collects metallic particles easily, because it is magnetized. Make sure that the magnetic encoder should not collect metallic particles. Check that there is not any trouble prior to reassembling it.
- When installing the front driveshaft, make sure that it does not contact with the magnetic encoder (integrated with the inner oil seal) to avoid damage.
- Do not apply the vehicle weight on the wheel bearing before fully tightening the front driveshaft nut. Otherwise, the wheel bearing may be broken.

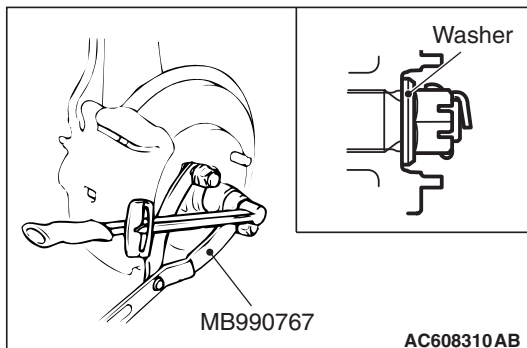
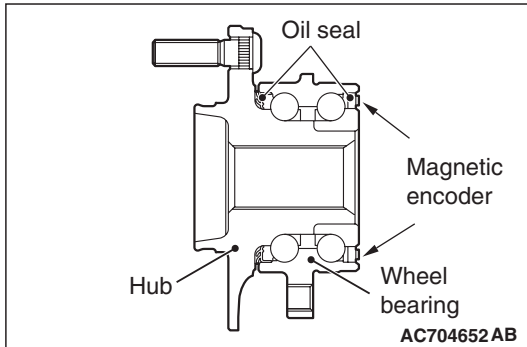

1. Be sure to install the front driveshaft washer in the illustrated direction.
2. Using special tool MB990767, tighten the driveshaft nut. At this time, tighten the nut to the specified lower limit torque so that the pin hole may align with cotter pin.

Tightening torque: 144 –176 N· m (107 –129 ft-lb)

3. If the pin hole does not align with the pin, tighten the driveshaft nut [less than 176 N· m (129 ft-lb)] and find the nearest hole, then fit the cotter pin.

INSPECTION

M1261001800435

WHEEL BEARING ROTATION STARTING TORQUE AND END PLAY CHECK

Required Special Tools:

- MB990998: Front Hub Remover and Installer
- MB991000: Spacer
- MB990326: Preload Socket
- MB990685: Torque Wrench

1. Tighten special tools MB990998 and MB991000 to the specified torque.

Tightening torque: 144 –176 N· m (107 –129 ft-lb)

2. Hold the front wheel hub assembly in a vice with a wooden block.
3. Rotate the hub in order to seat the bearing.

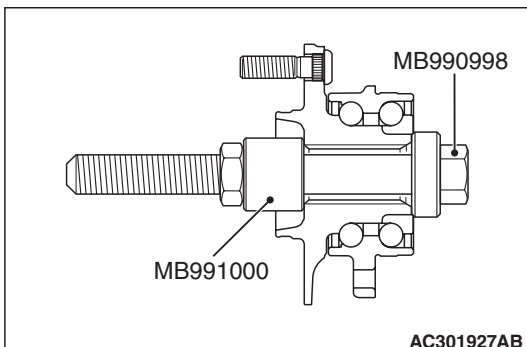

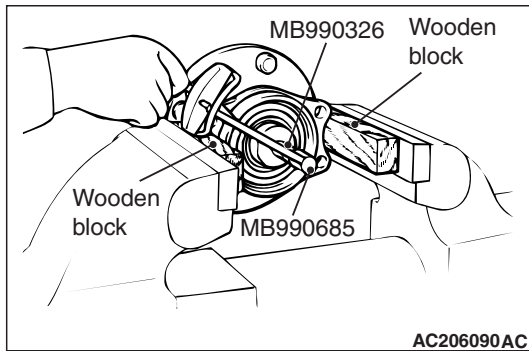

4. Measure the wheel bearing rotation starting torque by using special tools MB990326 and MB990685.

Limit: 1.4 N·m (12.39 in-lb)

5. If the rotation starting torque is not within the limit range, replace the front wheel hub assembly. If there is any signs of binding or tight spots when the wheel bearing turns, also replace it.

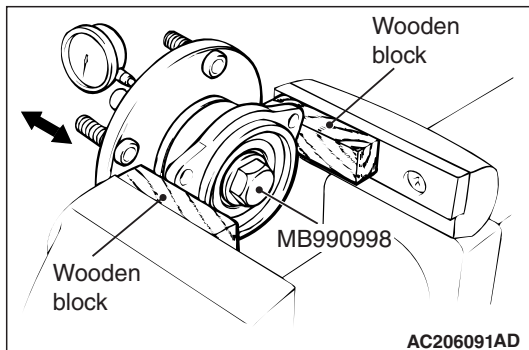

6. Measure to determine whether the wheel bearing end play is within the specified limit or not.

Limit: 0.05 mm (0.002 inch)

7. If the play is not within the limit range while the nut is tightened to 144 –176 N·m (107 –129 ft-lb), replace the front wheel hub assembly.

DRIVESHAFT ASSEMBLY

REMOVAL AND INSTALLATION

M1261003501422

CAUTION

- The magnetic encoder collects metallic particles easily, because it is magnetized. Make sure that the magnetic encoder should not collect metallic particles. Check that there is not any trouble prior to reassembling it.
- When removing and installing the front driveshaft assembly, make sure that the magnetic encoder (integrated with the inner oil seal) does not contact with surrounding parts to avoid damage.
- When removing and installing the front wheel speed sensor, make sure that the pole piece at the end does not contact with surrounding parts to avoid damage.
- The part indicated by * is the nut with friction coefficient stabilizer. In removal, ensure there is no damage, clean dust and soiling from the bearing and thread surfaces, and tighten them to the specified torque.

Pre-removal operation

- Transmission Oil Draining (Refer to GROUP 22A, On-vehicle Service, Transmission Oil Change P.22A-116.)
- Engine Room Under Cover Front Removal (Refer to GROUP51, Under Cover P.51-16.)

Post-installation operation

- Using your fingers, press the Ball Joint Dust Cover to check for a crack or damage.
- Transmission Oil Filling (Refer to GROUP 22A, On-vehicle Service, Transmission Oil Change P.22A-116.)
- Engine Room Under Cover Front Installation (Refer to GROUP51, Under Cover P.51-16.)

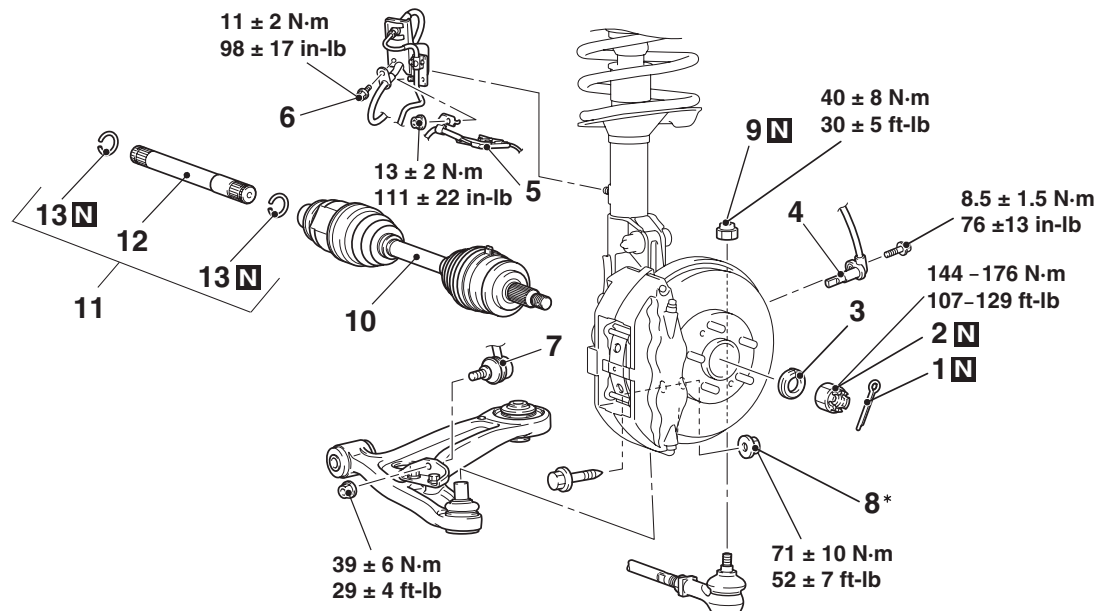

AC708540AC

Removal steps

- <<A>> >>B<<
>>B<<
1. Cotter pin
 2. Front driveshaft nut
 3. Washer
 4. Front wheel speed sensor
 5. Front wheel speed sensor harness clip
 6. Brake hose fixing bolt
 7. Front stabilizer link and lower arm connection

Removal steps (Continued)

- <>
<<C>> >>A<<
<<D>> >>A<<
8. Nut (lower arm ball joint connection)
 9. Self locking nut (tie-rod end connection)
 10. Front driveshaft assembly
 11. Output shaft assembly <M/T>
 12. Output shaft
 13. Circlip

Required Special Tools:

- MB990242: Puller Shaft
- MB990244: Puller Bar
- MB990767: Front Hub and Flange Yoke Holder
- MB991354: Puller Body
- MB991897 or MB992011: Ball Joint Remover

REMOVAL SERVICE POINTS**<<A>> FRONT DRIVESHAFT NUT REMOVAL****⚠ CAUTION**

Do not apply the vehicle weight on the front wheel hub assembly with the driveshaft nut loosened. Otherwise, the wheel bearing may be broken.

Use special tool MB990767 to counter the hub as shown in the figure to remove the front driveshaft nut.

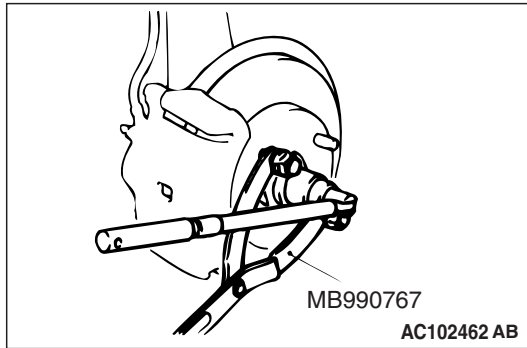
**<> SELF-LOCKING NUT (TIE-ROD END CONNECTION) REMOVAL****⚠ CAUTION**

- Loosen the self-locking nut (tie-rod end connection) from the ball joint, but do not remove here. Use the special tool.
- To prevent the special tool from dropping off, suspend it with a rope.
- If the dust cover is damaged during operation, replace the tie-rod end. (Refer to GROUP 37 –Power Steering Gear and Linkage Disassembly and Reassembly P.37-36.)

1. Install special tool MB991897 or MB992011 as shown in the figure.

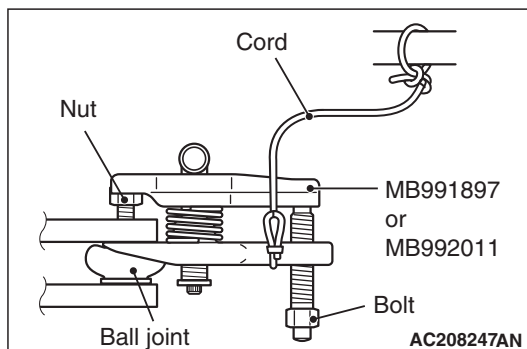

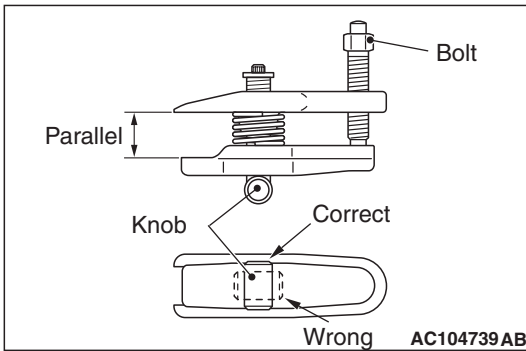

2. Turn the bolt and knob to make the special tool jaws parallel, then hand-tighten the bolt. After tightening, check that the jaws are still parallel.

NOTE: To adjust the special tool jaws to be parallel, set the orientation of the knob as shown in the figure.

3. Tighten the bolt with a wrench to disconnect the tie rod end.

<<C>>FRONT DRIVESHAFT ASSEMBLY REMOVAL

⚠ CAUTION

- The magnetic encoder collects metallic particles easily, because it is magnetized. Make sure that the magnetic encoder does not collect metallic particles.
- When removing the front driveshaft, make sure that it does not contact with the magnetic encoder (integrated with the inner oil seal) to avoid damage.

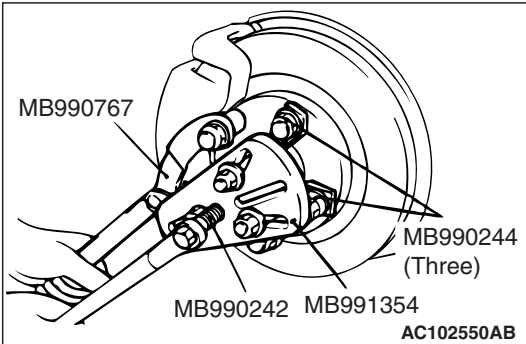
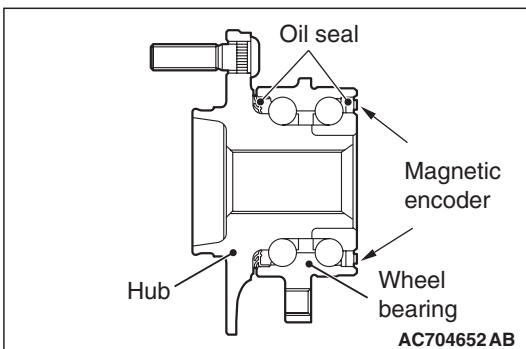

1. If the driveshaft is seized with the hub, use special tools MB990242 and MB990244, MB990767 and MB991354 to push the driveshaft assembly out from the hub.

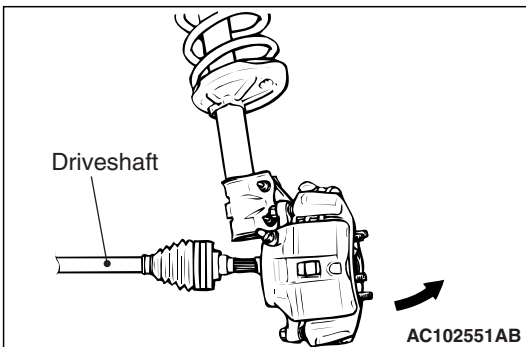

2. While pulling the lower side of the brake disk toward you, remove the driveshaft assembly from the hub.

⚠ CAUTION

- Never pull out the front driveshaft assembly from the EBJ assembly side. Otherwise, the ETJ assembly may be damaged. Always pull out from the ETJ side with a lever.
 - Care must be taken to ensure that the oil seal of the transaxle is not damaged by the spline part of the front driveshaft assembly.
3. Insert a lever between the transaxle case or transfer and front driveshaft assembly, and then pull the front driveshaft assembly out from the transaxle.

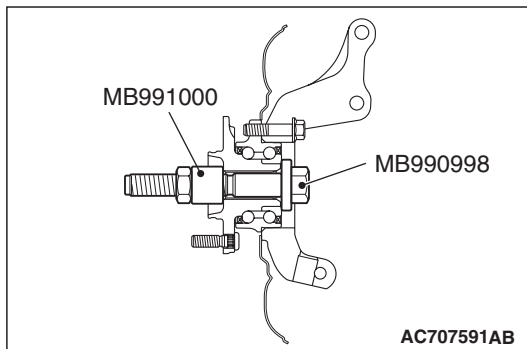
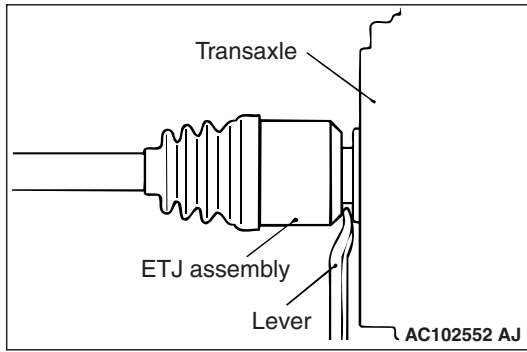
**⚠ CAUTION**

Do not apply the vehicle weight to the wheel bearing with the front driveshaft assembly removed. If, however, the vehicle weight shall be applied to the bearing (in order to move the vehicle), tighten the following special tools MB991000 and MB990998 to the specified torque 144 –176 N·m (107 –129 ft-lb).

<<D>>OUTPUT SHAFT ASSEMBLY REMOVAL**⚠ CAUTION**

When pulling the output shaft out from the transaxle, be careful that the spline part of the output shaft does not damage the oil seal.

Use special tool MB991721 to remove the output shaft assembly.

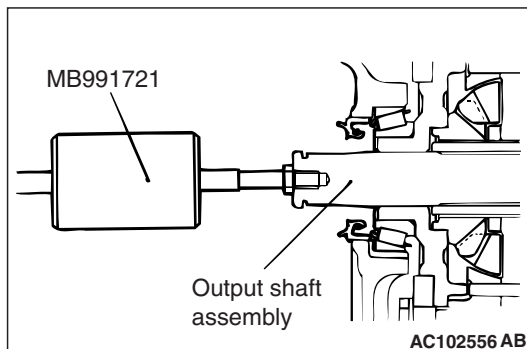

INSTALLATION SERVICE POINTS

>>A<< OUTPUT SHAFT ASSEMBLY/FRONT DRIVESHAFT ASSEMBLY INSTALLATION

⚠ CAUTION

- The magnetic encoder collects metallic particles easily, because it is magnetized. Make sure that the magnetic encoder should not collect metallic particles. Check that there is not any trouble prior to reassembling it.
- When installing the front driveshaft, make sure that it does not contact with the magnetic encoder (integrated with the inner oil seal) to avoid damage.
- Care must be taken to ensure that the oil seal of the transaxle is not damaged by the spline part of the output shaft assembly or front driveshaft assembly.

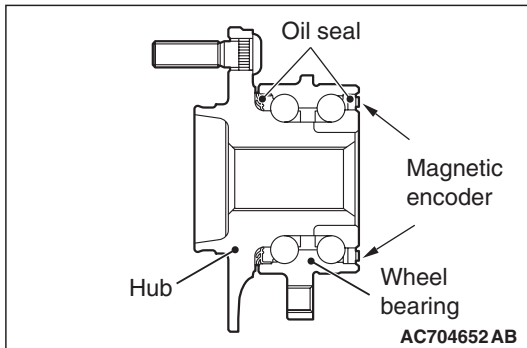

>>B<< WASHER/FRONT DRIVESHAFT NUT INSTALLATION

⚠ CAUTION

Do not apply the vehicle weight on the front wheel hub assembly before fully tightening the front driveshaft nut. Otherwise, the wheel bearing may be broken.

1. Be sure to install the front driveshaft washer in the illustrated direction.
2. Using special tool MB990767, tighten the driveshaft nut. At this time, tighten the nut to the specified lower limit torque so that the pin hole may align with cotter pin.

Tightening torque: 144 –176 N· m (107 –129 ft-lb)

3. If the pin hole does not align with the pin, tighten the driveshaft nut [less than 176 N· m (129 ft-lb)] and find the nearest hole, then fit the cotter pin.

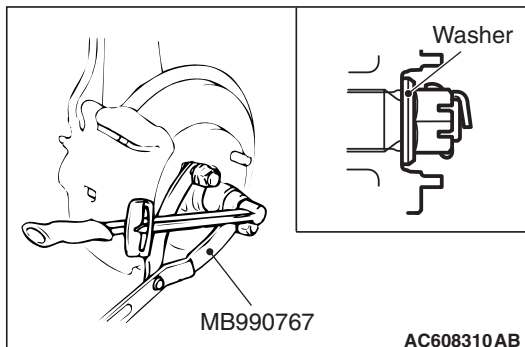

DISASSEMBLY AND ASSEMBLY

CAUTION

As for the EBJ assembly, only the EBJ boot can be replaceable, and other parts cannot be disassembled.

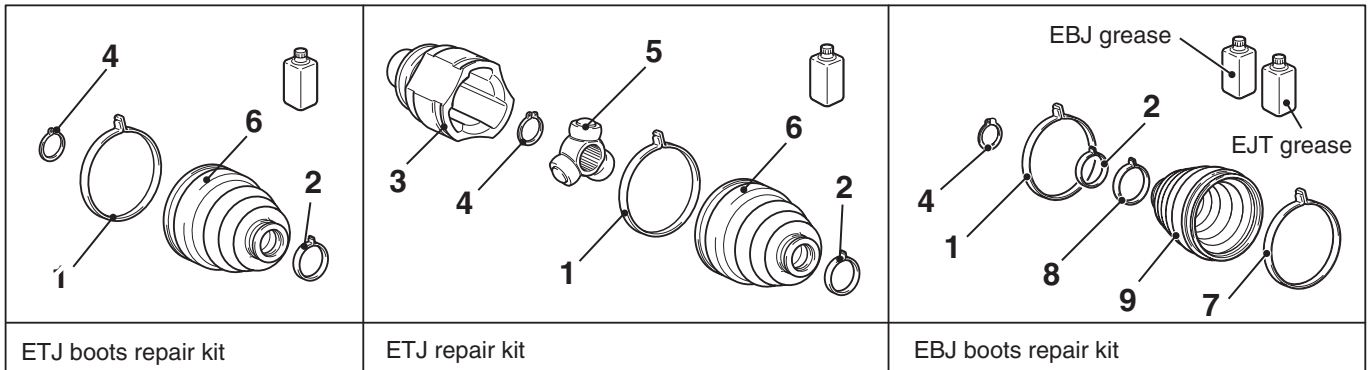
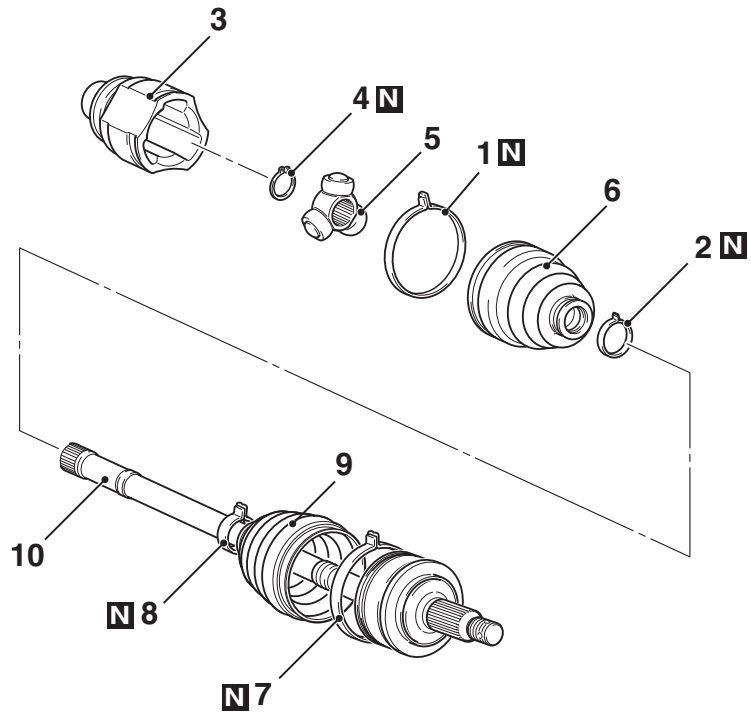

AC705138AB

Disassembly steps

- >>C<< 1. ETJ boot band (large)
- >>C<< 2. ETJ boot band (small)
- <<A>> >>B<< 3. ETJ case
- >>B<< 4. Snap ring
- >>B<< 5. Spider assembly

Disassembly steps (Continued)

- <> >>A<< 6. ETJ boot
- 7. EBJ boot band (large)
- 8. EBJ boot band (small)
- 9. EBJ boot
- 10. EBJ assembly

LUBRICATION POINTS

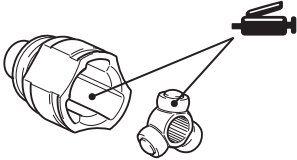

Grease: Repair kit grease
amount: 120 – 10 g (4.2 – 0.3 oz)

CAUTION
The drive shaft joint uses special grease, do not mix old and new or different types of grease.

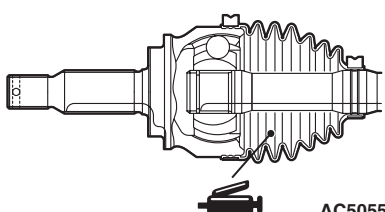

Grease: Repair kit grease
amount: 105 – 10 g (3.7 – 0.3 oz)

CAUTION
The drive shaft joint uses special grease, do not mix old and new or different types of grease.

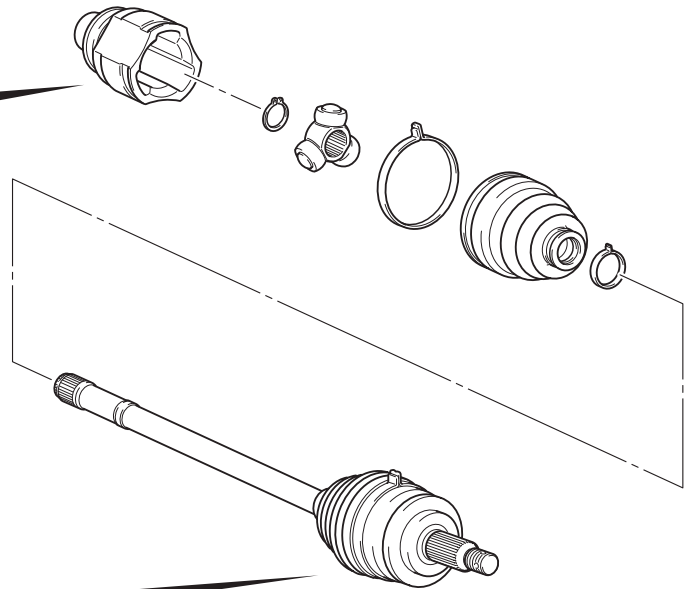

AC705977AB

DISASSEMBLY SERVICE POINTS

<<A>> ETJ CASE REMOVAL

CAUTION
Never disassemble the spider assembly.

<> ETJ BOOT REMOVAL

1. Wipe off the grease on the shaft spline.
2. When reusing the ETJ boot, wrap plastic tape around the shaft spline to avoid damaging the boot.

ASSEMBLY SERVICE POINTS

>>A<< ETJ BOOT INSTALLATION

Apply a tape to the shaft spline area. Then incorporate the ETJ boot.

>>B<< SPIDER ASSEMBLY/ETJ CASE
INSTALLATION**⚠ CAUTION**

- The driveshaft joint use special grease. Do not mix old and new or different types of grease.
- If the spider assembly has been cleaned, take special care to apply the specified grease.

1. Apply the specified grease furnished in the repair kit to the spider assembly between the spider axle and the roller.

Specified grease: Repair kit grease

2. Install the spider assembly to the shaft from the direction of the spline chamfered side.

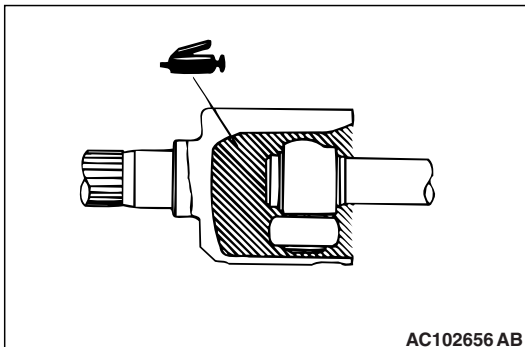
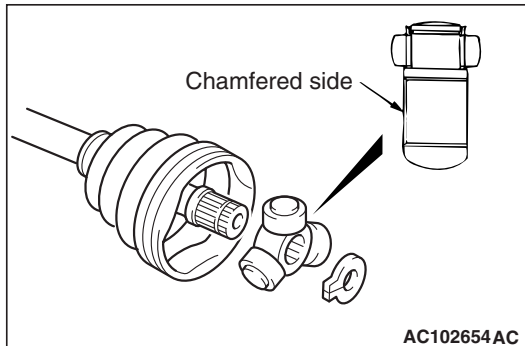

3. After applying the specified grease to the ETJ case, insert the driveshaft and apply grease one more time.

Specified grease: Repair kit grease**Amount to use: 120 ± 10 g (4.2 ± 0.3 ounce)**

NOTE: When using the repair kit grease, fill the half of the grease into the joint and the other half into the boot as a guideline, and consume the grease completely.

>>C<< ETJ BOOT BAND (SMALL)/ETJ BOOT
BAND (LARGE) INSTALLATION

Adjust the distance (A shown in the illustration) between the boot bands to the standard value to adjust the air volume inside the ETJ boot to the specified value, then be sure to tighten the ETJ boot band (large) and ETJ boot band (small).

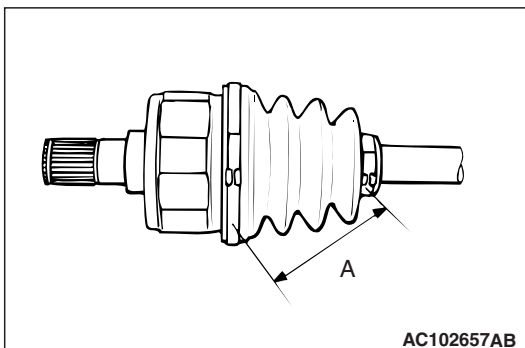
Standard value (A): 80 ± 3 mm (3.14 ± 0.12 inches)

EBJ BOOT REPLACEMENT

M1261007500197

Required Special Tool:

MB991561: Boot Band Crimping Tool

1. Remove the boot bands (large and small).
NOTE: The boot bands cannot be re-used.

2. Remove the EBJ boot.

3. Wrap a plastic tape around the shaft spline, and assemble the boot band and EBJ boot.

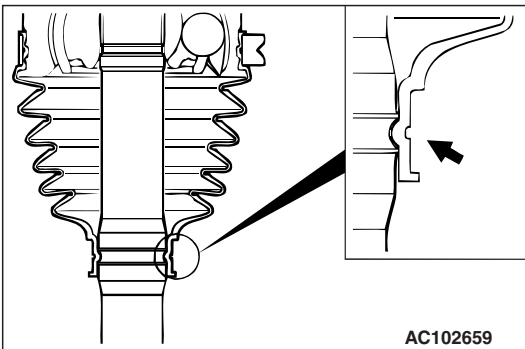
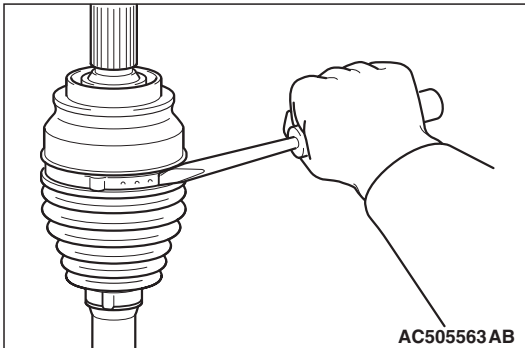

4. Align the center groove on the EBJ boot small end with the shaft groove.

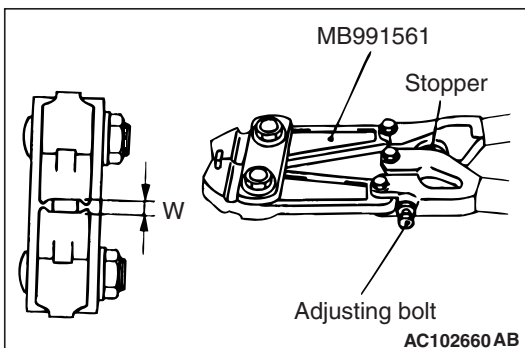

5. Turn the adjusting bolt on special tool MB991561 so that the size of the opening (W) is at the standard value.

Standard value (W): 2.9 mm (0.11 inch)

- If it is larger than 2.9 mm (0.11 inch)
Tighten the adjusting bolt.
- If it is smaller than 2.9 mm (0.11 inch)
Loosen the adjusting bolt.

NOTE:

- The value of W will change by approximately 0.7 mm (0.03 inch) for each turn of the adjusting bolt.
- The adjusting bolt should not be turned more than once.

6. Position the EBJ boot band (small) so that there is even clearance at either end (A and B).

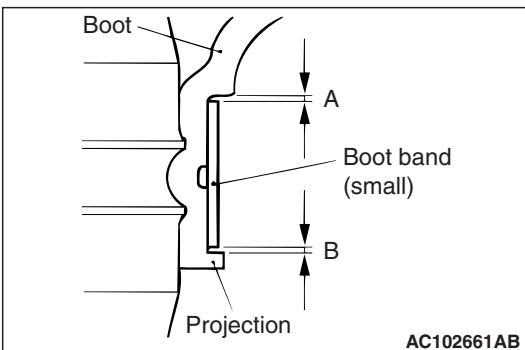

⚠ CAUTION

- Secure the driveshaft in an upright position and clamp part of the boot band to be crimped securely in the jaws of the special tool MB991561.
- Crimp the boot band until special tool MB991561 touches the stopper.

7. Use special tool MB991561 to crimp the boot band (small).

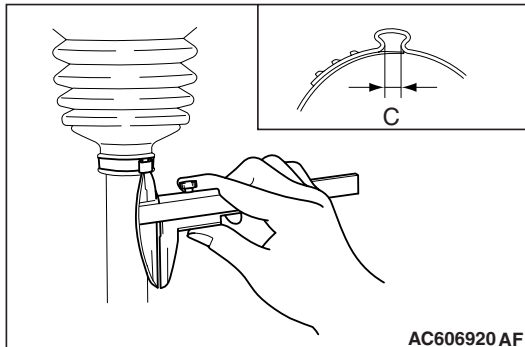
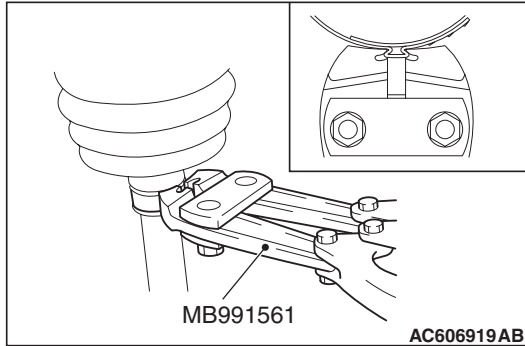

8. Check that the crimping amount (C) of the boot band is at the standard value.

Standard value (C): 2.4 –2.8 mm (0.10 –0.11 inch)

If the crimping amount is larger than 2.8 mm (0.11 inch)

Readjust the value of (W) in step 5 according to the following formula, and then repeat the operation in step 7.

$$W = 5.5 \text{ mm (0.22 inch)} - C$$

Example: If C = 2.9 mm (0.11 inch), then W = 2.6 mm (0.10 inch)

If the crimping amount is smaller than 2.4 mm (0.10 inch)

Remove the EBJ boot band, readjust the value of (W) in step 5 according to the following formula, and then repeat the operations in steps 6 and 7 using a new EBJ boot band.

$$W = 5.5 \text{ mm (0.22 inch)} - C$$

Example: If C = 2.3 mm (0.09 inch), then W = 3.2 mm (0.13 inch)

9. Check that the boot band is not sticking out past the place where it has been installed. If the boot band is sticking out, remove it and then repeat steps 6 to 8, using a new boot band.

⚠ CAUTION

- **The driveshaft joint uses special grease. Do not mix old and new or different types of grease.**

10. Fill the inside of the boot with the specified amount of the specified grease.

Specified grease: Repair kit grease

Amount to use: 105 ±10 g (3.7 ±0.3 ounces)

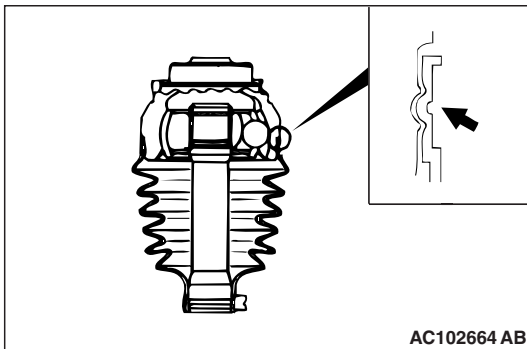

11. Align the center groove on the EBJ boot big end with the EBJ case groove.
12. Follow the same procedure as in step 5 to adjust the size of the opening (W) on the special tool so that it is at the standard value.

Standard value (W): 3.2 mm (0.13 inch)

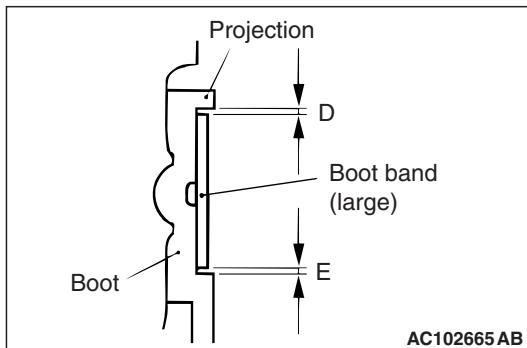

13. Position the EBJ boot band (large) so that there is even clearance at either end (D and E).
14. Use special tool MB991561 to crimp the EBJ boot band (large) in the same way as in step 7.

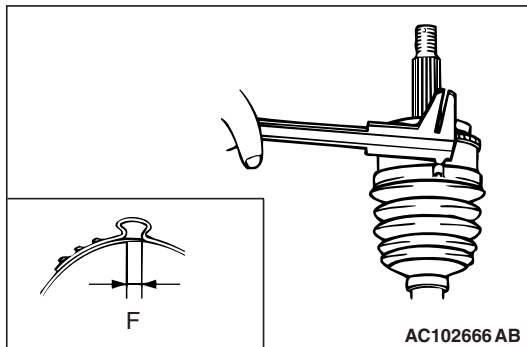

15. Check that the crimping amount (F) of the boot band is at the standard value.

Standard value (F): 2.4 –2.8 mm (0.10 –0.11 inch)

If the crimping amount is larger than 2.8 mm (0.11 inch)

Readjust the value of (W) in step 12 according to the following formula, and then repeat the operation in step 14.

$$W = 5.8 \text{ mm (0.23 inch)} - F$$

Example: If F = 2.9 mm (0.11 inch), then W = 2.9 mm (0.11 inch)

If the crimping amount is smaller than 2.4 mm (0.10 inch)

Remove the EBJ boot band, readjust the value of (W) in step 12 according to the following formula, and then repeat the operations in steps 13 and 14 using a new EBJ boot band.

$$W = 5.8 \text{ mm (0.23 inch)} - F$$

Example: If F = 2.3 mm (0.09 inch), then W = 3.5 mm (0.14 inch)

16. Check that the boot band is not sticking out past the place where it has been installed. If the boot band is sticking out, remove it and then repeat steps 13 to 15, using a new boot band.

NOTES