

SYMPTOM PROCEDURES

Inspection procedure 1: Communication with ECM only is not possible

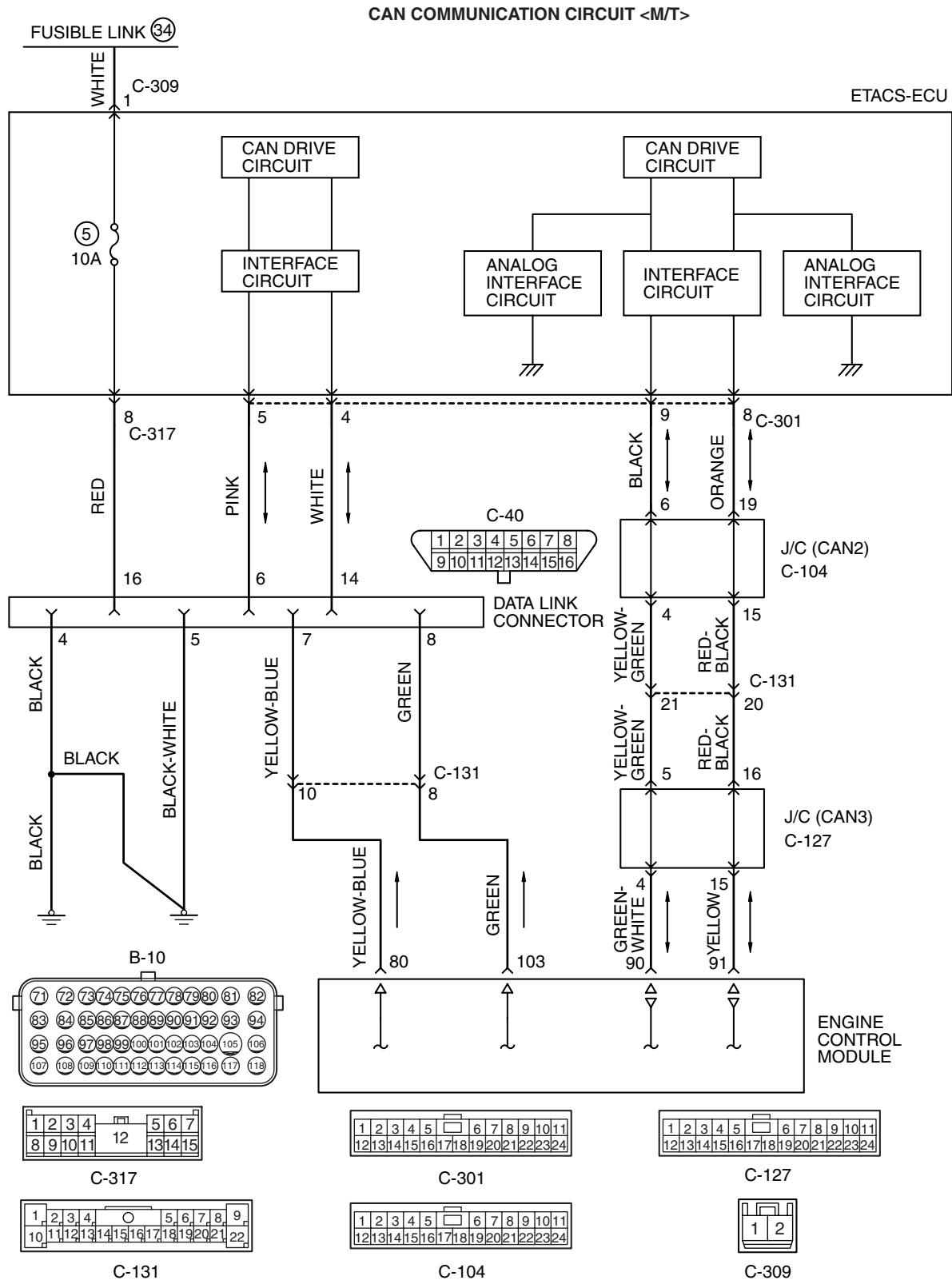

CAN COMMUNICATION CIRCUIT <TC-SST>

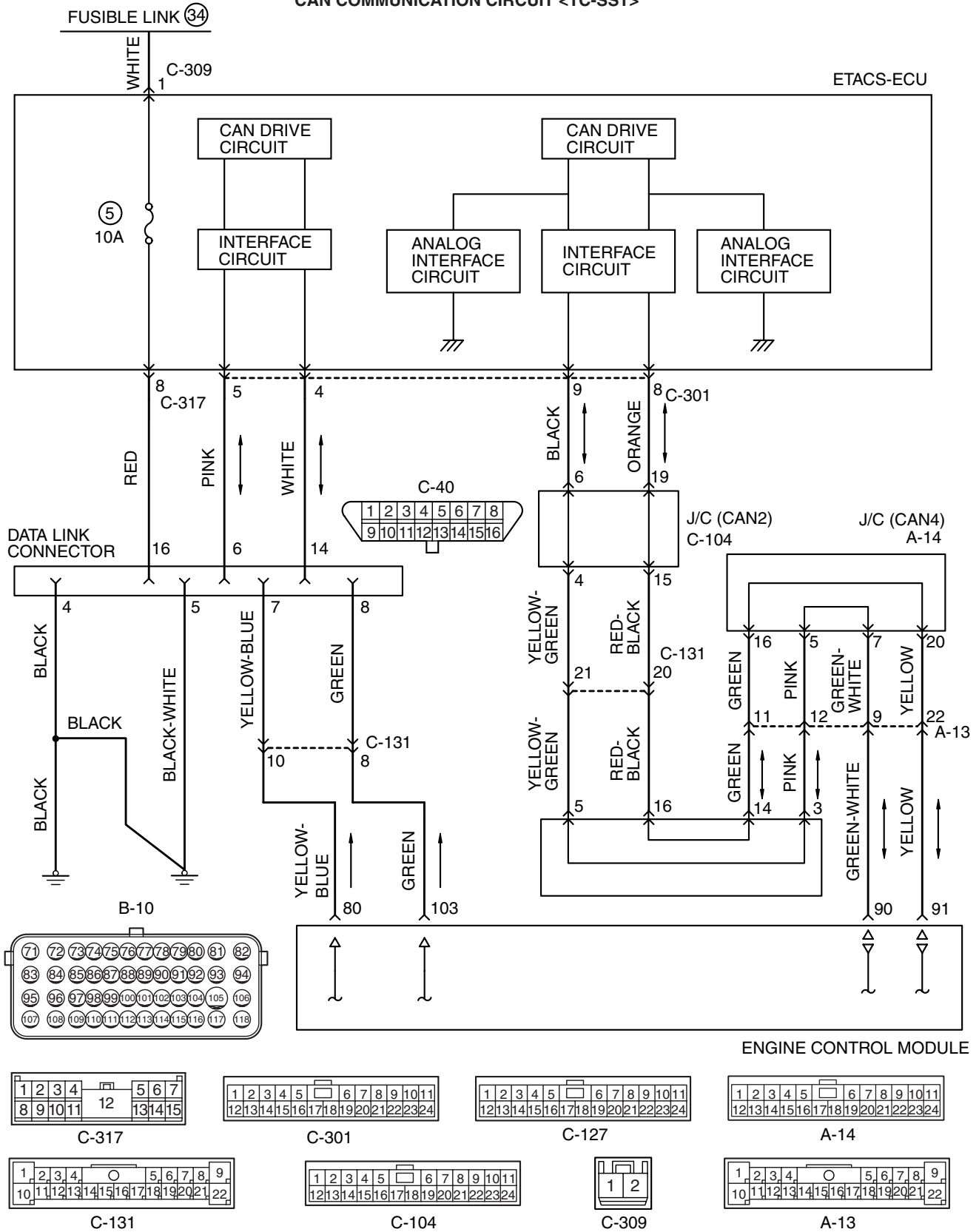

AK704287AB

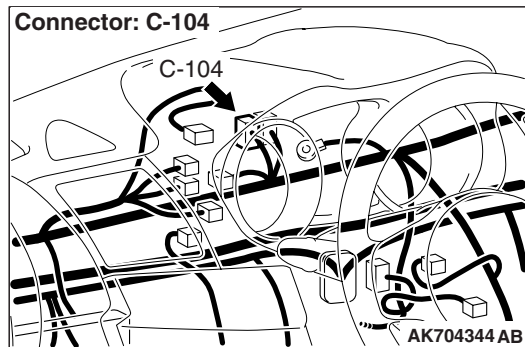
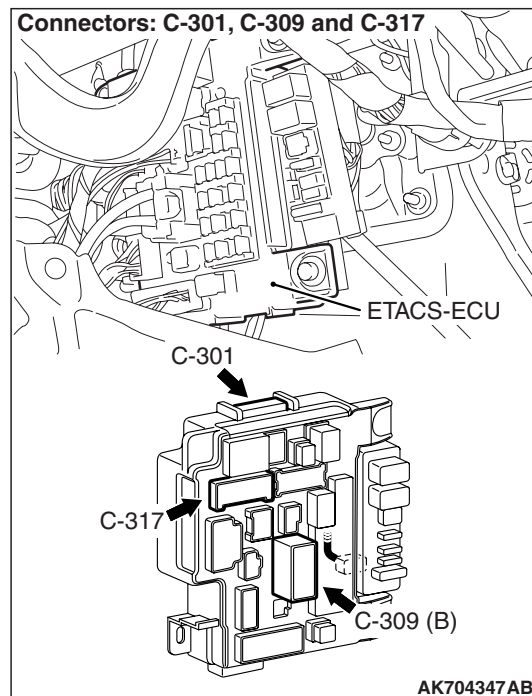
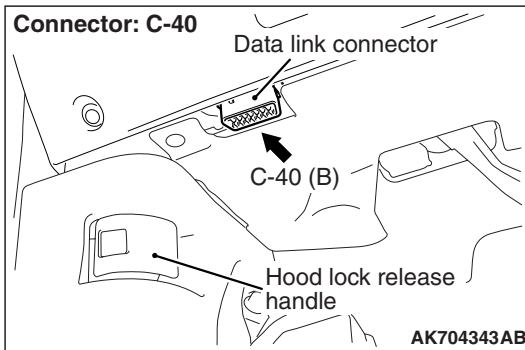
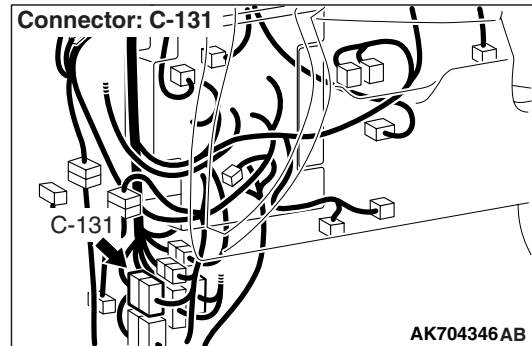
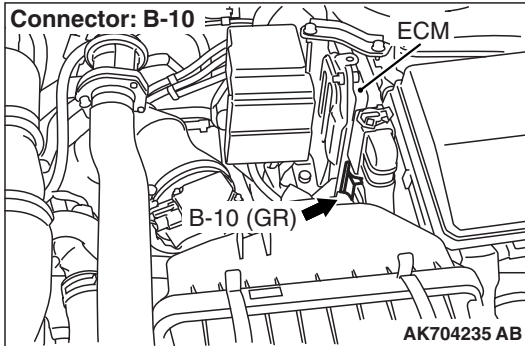
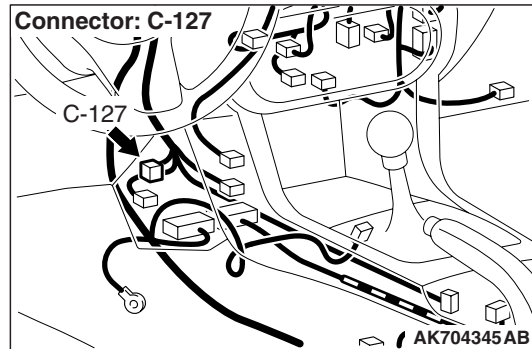
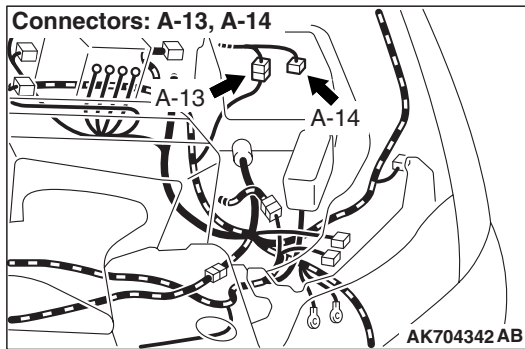

CIRCUIT OPERATION

- Battery voltage is applied to the diagnosis connector (terminal No. 16).
- The diagnosis connector (terminal No. 4 and No. 5) is grounded to the vehicle body.

COMMENT

- When the communication between M.U.T.-III and ECM is impossible, it can be suspected that the CAN bus line, power supply circuit of the diagnosis connector, and/or grounding circuit are defective.
- Communication can not be achieved either, if a wrong vehicle type is selected on M.U.T.-III.

TROUBLESHOOTING HINTS (The most likely causes for this case:)

- Malfunction of the data link connector.
- Open/short circuit or poor contact in the data link connector.
- Malfunction of the CAN communication.
- Malfunction of the scan tool.
- Malfunction of the ECM.

DIAGNOSIS**Required Special Tools:**

- MB991958: Scan tool (M.U.T.-III Sub Assembly)
 - MB991824: V.C.I.
 - MB991827: USB Cable
 - MB991910: Main Harness A

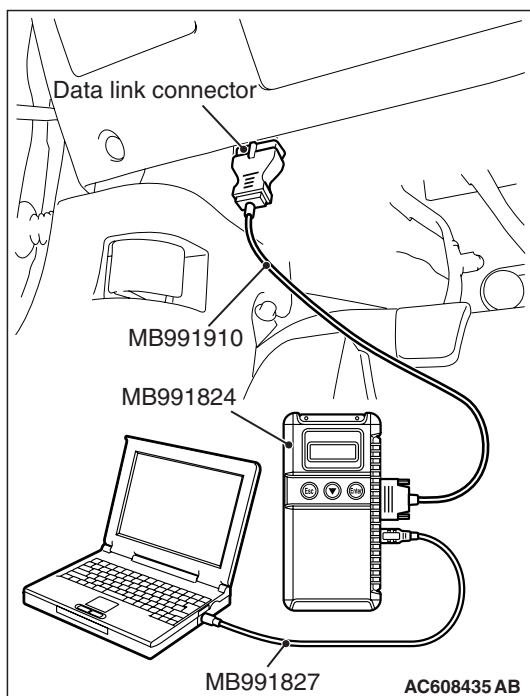
**STEP 1. Check the vehicle communication interface (V.C.I.) MB991824 operations.**

- (1) Connect the Scan tool to the data link connector.
- (2) When the power of V.C.I. is turned to ON, the indicator lamp of the V.C.I. illuminates in green.
 - The indicator lamp of the V.C.I. illuminates in green.

Q: Is the indicator lamp of the V.C.I. illuminates in green?**YES :** Go to Step 2.**NO :** Use scan tool, perform CAN bus line diagnosis.**STEP 2. Measure the battery positive voltage.**

- (1) Measure the battery positive voltage during cranking.
 - The voltage should be 8 volts or more.

Q: Is the measured voltage 8 volts or more?**YES :** Go to Step 3.**NO :** Check the battery. Refer to GROUP 54A, Battery – On-vehicle Service –Battery Test [P.54A-9](#). Then confirm that the malfunction symptom is eliminated.**STEP 3. Check harness connector C-40 at data link connector for damage.****Q: Is the harness connector in good condition?****YES :** Go to Step 4.**NO :** Repair or replace it. Refer to GROUP 00E, Harness Connector Inspection [P.00E-2](#). Then confirm that the malfunction symptom is eliminated.

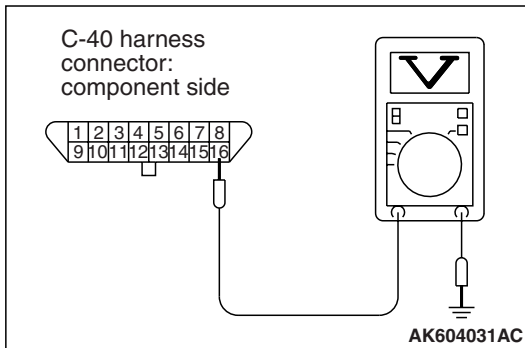

STEP 4. Measure the power supply voltage at data link connector C-40.

- (1) Measure voltage between terminal No. 16 and ground.
- Voltage should be battery positive voltage.

Q: Is battery positive voltage (approximately 12 volts) present?

YES : Go to Step 5.

NO : Repair an open circuit between ETACS-ECU connector C-317 (terminal No. 8) and data link connector C-40 (terminal No. 16). Then confirm that the malfunction symptom is eliminated.

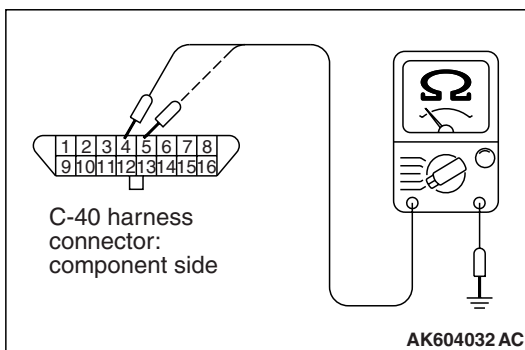

STEP 5. Check the continuity at data link connector C-40.

- (1) Check for the continuity between terminal No. 4, No. 5 and ground.
- Should be less than 2 ohms.

Q: Does continuity exist?

YES : Check and replace the scan tool. Then confirm that the malfunction symptom is eliminated.

NO : Repair an open circuit or harness damage between data link connector C-40 (terminal No. 4, No. 5) and ground. Then confirm that the malfunction symptom is eliminated.

Inspection procedure 2: The malfunction indicator lamp (SERVICE ENGINE SOON or check engine lamp) does not illuminate right after the ignition switch is turned to the "ON" position

CIRCUIT OPERATION

- The combination meter causes the malfunction indicator lamp (SERVICE ENGINE SOON or Check Engine Lamp) to illuminate for 20 seconds immediately after the ignition switch is turned to the "ON" position occurred.

TROUBLESHOOTING HINTS (The most likely causes for this case:)

- Malfunction of the malfunction indicator lamp (SERVICE ENGINE SOON or Check Engine Lamp).
- Open or shorted malfunction indicator lamp (SERVICE ENGINE SOON or Check Engine Lamp) circuit.

DIAGNOSIS**STEP 1. Check the trouble symptoms.**

- (1) Turn the ignition switch to the "ON" position.
 - The malfunction indicator lamp (SERVICE ENGINE SOON or Check Engine Lamp) should illuminate immediately after the ignition switch is turned to the "ON" position.
- (2) Turn the ignition switch to the "LOCK" (OFF) position.

Q: Does the malfunction indicator lamp (SERVICE ENGINE SOON or Check Engine Lamp) illuminate?

- YES :** It can be assumed that this malfunction is intermittent. Refer to GROUP 00, How to Use Troubleshooting/Inspection Service Points –How to Cope with Intermittent Malfunctions [P.00-15](#).
- NO :** Replace the combination meter.

Inspection procedure 3: The malfunction indicator lamp (SERVICE ENGINE SOON or check engine lamp) remains illuminated and never goes out

COMMENT

- In cases such as the above, the cause is probably that the ECM is detecting a problem in a sensor or actuator, or that one of the malfunctions listed below has probably occurred.

TROUBLESHOOTING HINTS (The most likely causes for this case:)

- Shorted malfunction indicator lamp (SERVICE ENGINE SOON or Check Engine Lamp) circuit.

DIAGNOSIS**Required Special Tools:**

- Scan Tool (M.U.T.-III Sub Assembly)
 - MB991824: V.C.I.
 - MB991827: USB Cable
 - MB991910: Main Harness A

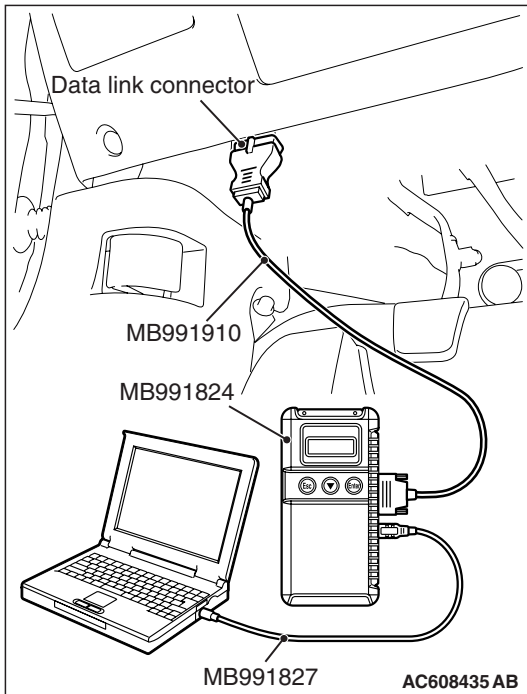

STEP 1. Using scan tool MB991958, read the diagnostic trouble code (DTC).

⚠ CAUTION

To prevent damage to scan tool MB991958, always turn the ignition switch to the "LOCK" (OFF) position before connecting or disconnecting scan tool MB991958.

- (1) Connect scan tool MB991958 to the data link connector.
- (2) Turn the ignition switch to the "ON" position.
- (3) Read the DTC.
- (4) Turn the ignition switch to the "LOCK" (OFF) position.

Q: Is any DTC set?

YES : Refer to Diagnostic Trouble Code Chart [P.13A-44](#).

NO : Go to Step 2.

STEP 2. Check the trouble symptoms.

- (1) Turn the ignition switch to the "ON" position.
 - The malfunction indicator lamp (SERVICE ENGINE SOON or Check Engine Lamp) should go out when 20 seconds have passed after the ignition switch was turned to the "ON" position.
- (2) Turn the ignition switch to the "LOCK" (OFF) position.

Q: Does the malfunction indicator lamp (SERVICE ENGINE SOON or Check Engine Lamp) go out?

YES : It can be assumed that this malfunction is intermittent. Refer to GROUP 00, How to Use Troubleshooting/Inspection Service Points –How to Cope with Intermittent Malfunctions [P.00-15](#).

NO : Replace the combination meter.

Inspection procedure 4: Cranks, won't start

Cranks, Won't Start Circuit

- Refer to Ignition circuit [P.13A-842](#).

CIRCUIT OPERATION

- Refer to Ignition circuit [P.13A-842](#).

COMMENT

- In cases such as the above, the cause is probably no spark, fuel delivery, or fuel quality problems. In addition, foreign materials (water, kerosene, etc.) may be mixed with the fuel.

TROUBLESHOOTING HINTS (The most likely causes for this case:)

- Malfunction of the battery.
- Malfunction of the immobilizer system.
- Malfunction of the fuel pump system.
- Malfunction of the ignition system.
- Malfunction of the injector system.
- Poor compression
- Contaminated fuel.
- Timing chain in out of place.
- Malfunction of the ECM.

DIAGNOSIS**Required Special Tools:**

- MB991958: Scan Tool (M.U.T.-III Sub Assembly)
 - MB991824: V.C.I.
 - MB991827: USB Cable
 - MB991910: Main Harness A

STEP 1. Using scan tool MB991958, read the diagnostic trouble code (DTC).**⚠ CAUTION**

To prevent damage to scan tool MB991958, always turn the ignition switch to the "LOCK" (OFF) position before connecting or disconnecting scan tool MB991958.

- (1) Connect scan tool MB991958 to the data link connector.
- (2) Turn the ignition switch to the "ON" position after cranking the engine for at least 2 sec.
- (3) Read the DTC.
- (4) Turn the ignition switch to the "LOCK" (OFF) position.

Q: Is DTC set?

YES : Refer to Diagnostic Trouble Code Chart [P.13A-44](#).

NO : Go to Step 2.

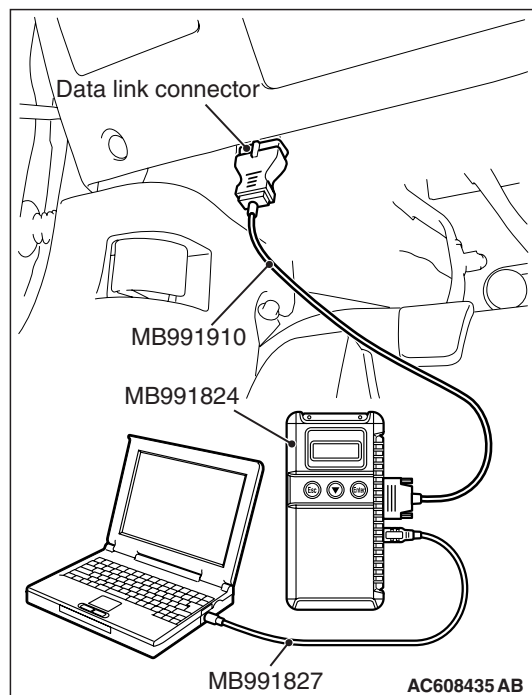

STEP 2. Check harness connector B-101, B-102, B-103, B-104 at injector for damage.

Q: Is the harness connector in good condition?

YES : Go to Step 3.

NO : Repair or replace it. Refer to GROUP 00E, Harness Connector Inspection [P.00E-2](#). Then confirm that the malfunction symptom is eliminated.

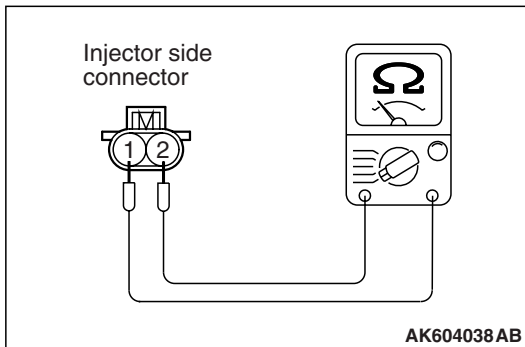

STEP 3. Check the injector.

(1) Disconnect the injector connector B-101, B-102, B-103, B-104.

(2) Measure the resistance between injector side connector terminal No. 1 and No. 2.

Standard value: 10.5 –13.5 Ω [at 20° C (68° F)]

Q: Is the measured resistance between 10.5 and 13.5 Ω [at 20° C (68° F)]?

YES : Go to Step 4.

NO : Replace the faulty injector. Then confirm that the malfunction symptom is eliminated.

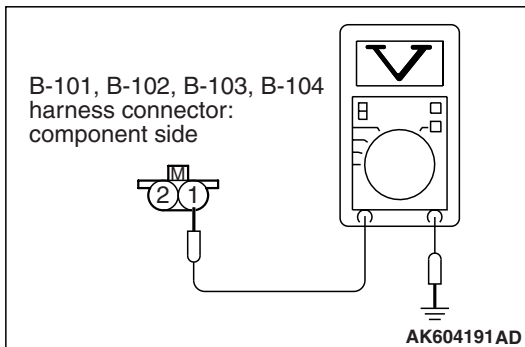

STEP 4. Measure the power supply voltage at injector connector.

(1) Disconnect connector B-101, B-102, B-103, B-104 and measure at the harness side.

(2) Turn the ignition switch to the "ON" position.

(3) Measure the voltage between terminal No. 1 and ground.

- Voltage should be battery positive voltage.

(4) Turn the ignition switch to the "LOCK" (OFF) position.

Q: Is battery positive voltage (approximately 12 volts) present?

YES : Go to Step 14.

NO : Go to Step 5.

STEP 5. Check harness connector A-25X at injector relay for damage.

Q: Is the harness connector in good condition?

YES : Go to Step 6.

NO : Repair or replace it. Refer to GROUP 00E, Harness Connector Inspection [P.00E-2](#). Then confirm that the malfunction symptom is eliminated.

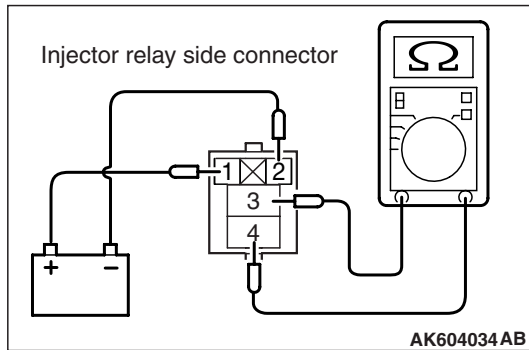
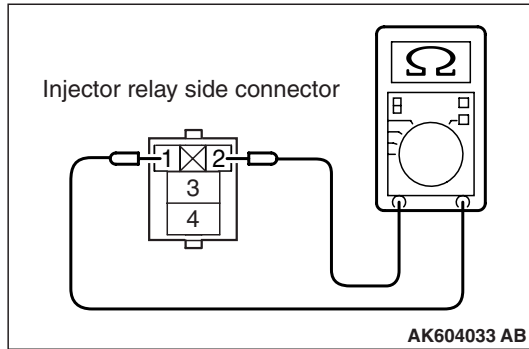
**STEP 6. Check the injector relay.**

- (1) Remove the injector relay.
- (2) Check for continuity between the injector relay terminal No. 1 and No. 2.
There should be continuity.

- (3) Use jumper wires to connect injector relay terminal No. 1 to the positive battery terminal and terminal No. 2 to the negative battery terminal.
- (4) Check for continuity between the injector relay terminal No. 3 and No. 4 while connecting and disconnecting the jumper wire at the negative battery terminal.
 - Continuity (2 ohms or less). <Negative battery terminal connected>
 - Should be open loop. <Negative battery terminal disconnected>
- (5) Install the injector relay.

Q: Is the measured resistance normal?**YES** : Go to Step 7.**NO** : Replace the injector relay. Then confirm that the malfunction symptom is eliminated.**STEP 7. Check for continuity at injector relay harness side connector A-25X.**

- (1) Disconnect the connector A-25X and measure at the harness side.
- (2) Check for the continuity between terminal No. 2 and ground.
 - Continuity (2 ohms or less).

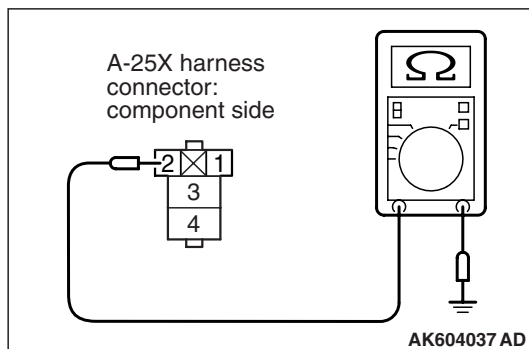
Q: Does continuity exist?**YES** : Go to Step 8.**NO** : Repair harness wire between injector relay connector A-25X (terminal No. 2) and ground because of open circuit or harness damage. Then confirm that the malfunction symptom is eliminated.

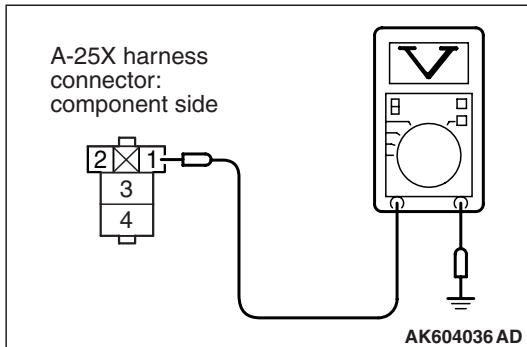

STEP 8. Measure the power supply voltage at injector relay harness side connector A-25X.

- (1) Disconnect the connector A-25X and measure at the harness side.
- (2) Turn the ignition switch to the "ON" position.
- (3) Measure the voltage between terminal No. 1 and ground.
 - Voltage should be battery positive voltage.

Q: Is battery positive voltage (approximately 12 volts) present?

YES : Go to Step 10.

NO : Go to Step 9.

STEP 9. Check harness connector C-304 at ETACS-ECU for damage.

Q: Is the harness connector in good condition?

YES : Check harness connector C-50 at intermediate connector for damage, and repair or replace as required. Refer to GROUP 00E, Harness Connector Inspection [P.00E-2](#). If intermediate connector is in good condition, repair harness wire between injector relay connector A-25X (terminal No. 1) and ETACS-ECU connector C-304 (terminal No. 10) because of open circuit or short circuit to ground. Then confirm that the malfunction symptom is eliminated.

NO : Repair or replace it. Refer to GROUP 00E, Harness Connector Inspection [P.00E-2](#). Then confirm that the malfunction symptom is eliminated.

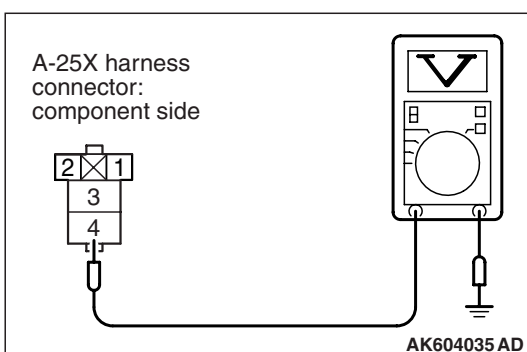

STEP 10. Measure the power supply voltage at injector relay harness side connector A-25X.

- (1) Disconnect the connector A-25X and measure at the harness side.
- (2) Turn the ignition switch to the "ON" position.
- (3) Measure the voltage between terminal No. 4 and ground.
 - Voltage should be battery positive voltage.

Q: Is battery positive voltage (approximately 12 volts) present?

YES : Go to Step 12.

NO : Go to Step 11.

STEP 11. Check harness connector A-34X at MFI relay for damage.

Q: Is the harness connector in good condition?

YES : Repair harness wire between MFI relay connector A-34X (terminal No. 2) and injector relay connector A-25X (terminal No. 4) because of open circuit or short circuit to ground. Then confirm that the malfunction symptom is eliminated.

NO : Repair or replace it. Refer to GROUP 00E, Harness Connector Inspection [P.00E-2](#). Then confirm that the malfunction symptom is eliminated.

STEP 12. Check for open circuit and short circuit to ground between injector relay connector and injector connector.

NOTE: Check harness connector after checking intermediate connector A-39. If intermediate connector is damaged, repair or replace it. Refer to GROUP 00E, Harness Connector Inspection [P.00E-2](#). Then confirm that the malfunction symptom is eliminated.

- a. Injector relay connector A-25X (terminal No. 3) and No. 1 cylinder injector connector B-101 (terminal No. 1).
- b. Injector relay connector A-25X (terminal No. 3) and No. 2 cylinder injector connector B-102 (terminal No. 1).
- c. Injector relay connector A-25X (terminal No. 3) and No. 3 cylinder injector connector B-103 (terminal No. 1).
- d. Injector relay connector A-25X (terminal No. 3) and No. 4 cylinder injector connector B-104 (terminal No. 1).

Q: Is the harness wire in good condition?

YES : Go to Step 13.

NO : Repair it. Then confirm that the malfunction symptom is eliminated.

STEP 13. Check harness connector C-304 at ETACS-ECU for damage.

Q: Is the harness connector in good condition?

YES : Check harness connector C-50 at intermediate connector for damage, and repair or replace as required. Refer to GROUP 00E, Harness Connector Inspection [P.00E-2](#). If intermediate connector is in good condition, repair harness wire between injector relay connector A-25X (terminal No. 1) and ETACS-ECU connector C-304 (terminal No. 10) because of harness damage. Then confirm that the malfunction symptom is eliminated.

NO : Repair or replace it. Refer to GROUP 00E, Harness Connector Inspection [P.00E-2](#). Then confirm that the malfunction symptom is eliminated.

STEP 14. Check harness connector A-34X at MFI relay for damage.

Q: Is the harness connector in good condition?

YES : Go to Step 15.

NO : Repair or replace it. Refer to GROUP 00E, Harness Connector Inspection [P.00E-2](#). Then confirm that the malfunction symptom is eliminated.

STEP 15. Check for harness damage between MFI relay connector A-34X (terminal No. 2) and injector relay connector A-25X (terminal No. 4).

Q: Is the harness wire in good condition?

YES : Go to Step 16.

NO : Repair it. Then confirm that the malfunction symptom is eliminated.

STEP 16. Check for harness damage between injector relay connector and injector connector.

NOTE: Check harness after checking intermediate connector A-39. If intermediate connector is damaged, repair or replace it. Refer to GROUP 00E, Harness Connector Inspection [P.00E-2](#). Then confirm that the malfunction symptom is eliminated.

- a. Injector relay connector A-25X (terminal No. 3) and No. 1 cylinder injector connector B-101 (terminal No. 1).
- b. Injector relay connector A-25X (terminal No. 3) and No. 2 cylinder injector connector B-102 (terminal No. 1).
- c. Injector relay connector A-25X (terminal No. 3) and No. 3 cylinder injector connector B-103 (terminal No. 1).
- d. Injector relay connector A-25X (terminal No. 3) and No. 4 cylinder injector connector B-104 (terminal No. 1).

Q: Is the harness wire in good condition?

YES : Go to Step 17.

NO : Repair it. Then confirm that the malfunction symptom is eliminated.

STEP 17. Using scan tool MB991958, check data list.

- (1) Turn the ignition switch to the "ON" position.
- (2) Check the following items in the data List. Refer to Data List Reference Table [P.13A-852](#).

- a. Item 1: Power Supply Voltage

- (3) Turn the ignition switch to the "LOCK" (OFF) position.

Q: Are they operating properly?

YES : Go to Step 18.

NO : Repair or replace it. Then confirm that the malfunction symptom is eliminated.

STEP 18. Using scan tool MB991958, check actuator test.

- (1) Turn the ignition switch to the "ON" position.
- (2) Check the following items in the actuator test. Refer to Actuator Test Reference Table [P.13A-871](#).
 - a. Item 9: Fuel pump
- (3) Turn the ignition switch to the "LOCK" (OFF) position.

Q: Is the actuator operating properly?

YES : Go to Step 19.

NO : Repair or replace it. Then confirm that the malfunction symptom is eliminated.

STEP 19. Check the fuel pressure.

Refer to Fuel Pressure Test [P.13A-897](#).

Q: Is the fuel pressure normal?

YES : Go to Step 20.

NO : Repair or replace it. Then confirm that the malfunction symptom is eliminated.

STEP 20. Check the ignition system.

- (1) Connect the timing light to terminal No. 4 of the ignition coil connector B-02, B-03, B-04 or B-06 in order.
- (2) Crank the engine.
 - The timing light flashes.
- (3) Turn the ignition switch to the "LOCK" (OFF) position.

Q: Does the timing light flash?

YES : Go to Step 21.

NO : Refer to inspection procedure 26 –Ignition circuit system [P.13A-842](#).

STEP 21. Check the spark plugs.

Refer to GROUP 16, Ignition System –On-vehicle Service – Spark Plug Check And Cleaning [P.16-37](#).

Q: Are there any abnormalities?

YES : Replace the spark plug. Then confirm that the malfunction symptom is eliminated.

NO : Go to Step 22.

STEP 22. Check the ignition coil.

Refer to GROUP 16, Ignition System –On-vehicle Service – Ignition Coil Check [P.16-36](#).

Q: Are there any abnormalities?

YES : Replace the ignition coil. Then confirm that the malfunction symptom is eliminated.

NO : Go to Step 23.

STEP 23. Check the compression pressure.

Refer to GROUP 11A, On-vehicle Service –Compression Pressure Check [P.11A-15](#).

Q: Is the compression pressure normal?

YES : Go to Step 24.

NO : Repair it. Then confirm that the malfunction symptom is eliminated.

STEP 24. Check the ignition timing.

Refer to GROUP 11A, On-vehicle Service –Ignition Timing Check [P.11A-10](#).

Q: Is the ignition timing normal?

YES : Check the following items, and repair or replace the defective items.

a. Check if the injectors are clogged.

b. Check if fuel is contaminated.

Then confirm that the malfunction symptom is eliminated.

NO : Check for installed conditions of the timing chain. Then confirm that the malfunction symptom is eliminated.

Inspection procedure 5: Starts up and dies

COMMENT

- In such cases as the above, the cause is usually improper air/fuel mixture. It is possible, though less likely, that the spark plugs are generating sparks but the sparks are weak.

TROUBLESHOOTING HINTS (The most likely causes for this case:)

- Malfunction of the fuel pump system.
- Malfunction of the ignition system.
- Malfunction of the injector system.
- Poor compression.
- Contaminated fuel.
- Dirtiness around throttle valve.
- Malfunction of the ECM.

DIAGNOSIS

Required Special Tools:

- MB991958: Scan Tool (M.U.T.-III Sub Assembly)
 - MB991824: V.C.I.
 - MB991827: USB Cable
 - MB991910: Main Harness A

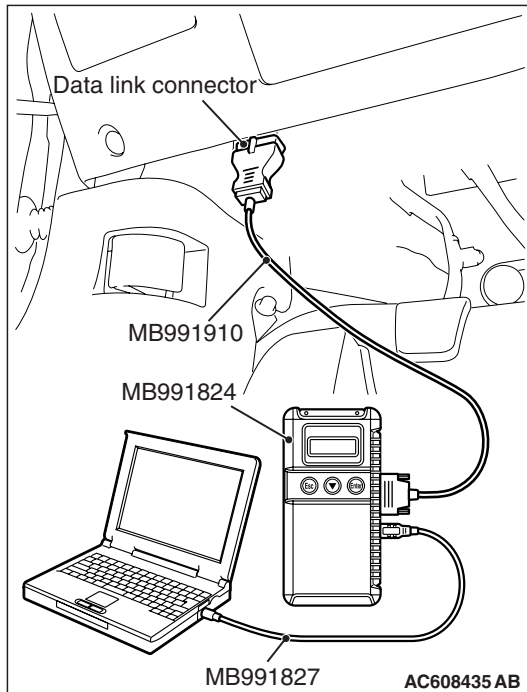

STEP 1. Using scan tool MB991958, read the diagnostic trouble code (DTC).

⚠ CAUTION

To prevent damage to scan tool MB991958, always turn the ignition switch to the "LOCK" (OFF) position before connecting or disconnecting scan tool MB991958.

- (1) Connect scan tool MB991958 to the data link connector.
- (2) Turn the ignition switch to the "ON" position.
- (3) Read the DTC.
- (4) Turn the ignition switch to the "LOCK" (OFF) position.

Q: Is DTC set?

YES : Refer to Diagnostic Trouble Code Chart [P.13A-44](#).

NO : Go to Step 2.

STEP 2. Using scan tool MB991958, check data list.

- (1) Turn the ignition switch to the "ON" position.
- (2) Check the following items in the data list. Refer to Data List Reference Table [P.13A-852](#).
 - a. Item 1: Power Supply Voltage
 - b. Item 6: Engine Coolant Temperature Sensor
- (3) Turn the ignition switch to the "LOCK" (OFF) position.

Q: Is the sensor operating properly?

YES : Go to Step 3.

NO : Repair or replace it. Then confirm that the malfunction symptom is eliminated.

STEP 3. Using scan tool MB991958, check actuator test.

- (1) Turn the ignition switch to the "ON" position.
- (2) Check the following items in the actuator test. Refer to Actuator Test Reference Table [P.13A-871](#).
 - a. Item 9: Fuel Pump.
- (3) Turn the ignition switch to the "LOCK" (OFF) position.

Q: Is the actuator operating properly?

YES : Go to Step 4.

NO : Repair or replace it. Then confirm that the malfunction symptom is eliminated.

STEP 4. Inspection of throttle body (throttle valve area) for dirtiness.

Q: Is the throttle valve area dirty?

YES : Refer to Throttle Body (Throttle Valve Area) Cleaning [P.13A-897](#).

NO : Go to Step 5.

STEP 5. Check the ignition timing.

Refer to GROUP 11A, On-vehicle Service –Ignition Timing Check [P.11A-10](#).

Q: Is the ignition timing normal?

YES : Go to Step 6.

NO : Check for installed conditions of the timing chain. Then confirm that the malfunction symptom is eliminated.

STEP 6. Check the fuel pressure.

Refer to Fuel Pressure Test [P.13A-897](#).

Q: Is the fuel pressure normal?

YES : Go to Step 7.

NO : Repair or replace it. Then confirm that the malfunction symptom is eliminated.

STEP 7. Check harness connector B-101, B-102, B-103, B-104 at injector for damage.

Q: Is the harness connector in good condition?

YES : Go to Step 8.

NO : Repair or replace it. Refer to GROUP 00E, Harness Connector Inspection [P.00E-2](#). Then confirm that the malfunction symptom is eliminated.

STEP 8. Check the injector resistance.

(1) Disconnect the left bank injector connector B-101, B-102, B-103, B-104.

(2) Measure the resistance between each injector side connector terminal No. 1 and No. 2.

Standard value: 10.5 –13.5 Ω [at 20° C (68° F)]

Q: Is the measured resistance between 10.5 and 13.5 ohms [at 20° C (68° F)]?

YES : Go to Step 9.

NO : Replace the faulty injector. Then confirm that the malfunction symptom is eliminated.

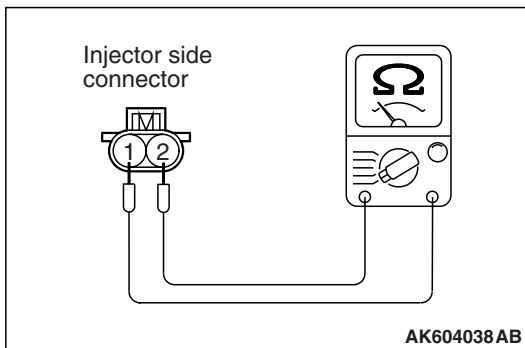

STEP 9. Check harness connector A-34X at MFI relay and harness connector A-25X at injector relay connector for damage.

Q: Is the harness connector in good condition?

YES : Go to Step 10.

NO : Repair or replace it. Refer to GROUP 00E, Harness Connector Inspection [P.00E-2](#). Then confirm that the malfunction symptom is eliminated.

STEP 10. Check for harness damage between MFI relay connector A-34X (terminal No. 2) and injector relay connector A-25X (terminal No. 4).

Q: Is the harness wire in good condition?

YES : Go to Step 11.

NO : Repair it. Then confirm that the malfunction symptom is eliminated.

STEP 11. Check for harness damage between injector relay connector and injector connector.

NOTE: Check harness after checking intermediate connector A-39. If intermediate connector is damaged, repair or replace it. Refer to GROUP 00E, Harness Connector Inspection [P.00E-2](#). Then confirm that the malfunction symptom is eliminated.

- a. Injector relay connector A-25X (terminal No. 3) and No. 1 cylinder injector connector B-101 (terminal No. 1).
- b. Injector relay connector A-25X (terminal No. 3) and No. 2 cylinder injector connector B-102 (terminal No. 1).
- c. Injector relay connector A-25X (terminal No. 3) and No. 3 cylinder injector connector B-103 (terminal No. 1).
- d. Injector relay connector A-25X (terminal No. 3) and No. 4 cylinder injector connector B-104 (terminal No. 1).

Q: Is the harness wire in good condition?

YES : Go to Step 12.

NO : Repair it. Then confirm that the malfunction symptom is eliminated.

STEP 12. Check the spark plugs.

Refer to GROUP 16, Ignition System –On-vehicle Service – Spark Plug Check And Cleaning [P.16-37](#).

Q: Are there any abnormalities?

YES : Replace the spark plug. Then confirm that the malfunction symptom is eliminated.

NO : Go to Step 13.

STEP 13. Check the ignition coil.

- (1) Remove the intake manifold.
- (2) Refer to GROUP 16, Ignition System –On-vehicle Service – Ignition Coil Check [P.16-36](#).

Q: Are there any abnormalities?

YES : Replace the ignition coil. Then confirm that the malfunction symptom is eliminated.

NO : Go to Step 14.

STEP 14. Check the compression pressure.

Refer to GROUP 11A, On-vehicle Service –Compression Pressure Check [P.11A-15](#).

Q: Is the compression pressure normal?

YES : Check the following items, and repair or replace the defective items.

- a. Check fuel lines for clogging.
- b. Check if fuel is contaminated.
- c. Check if the injectors are clogged.

Then confirm that the malfunction symptom is eliminated.

NO : Repair it. Then confirm that the malfunction symptom is eliminated.

Inspection procedure 6: Hard starting

COMMENT

- In cases such as the above, the cause is usually either weak spark, improper air-fuel mixture or low compression.

TROUBLESHOOTING HINTS (The most likely causes for this case:)

- Malfunction of the fuel pump system.
- Malfunction of the ignition system.
- Malfunction of the injector system.
- Poor compression
- Contaminated fuel.
- Malfunction of the ECM.

DIAGNOSIS

Required Special Tools:

- MB991958: Scan Tool (M.U.T.-III Sub Assembly)
 - MB991824: V.C.I.
 - MB991827: USB Cable
 - MB991910: Main Harness A

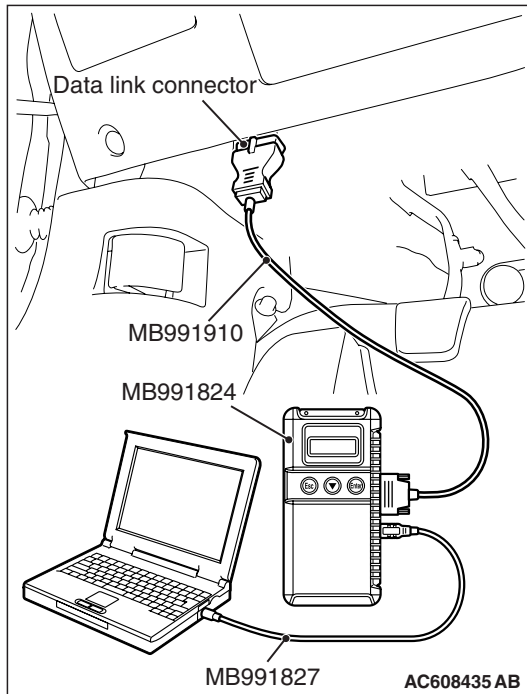

STEP 1. Using scan tool MB991958, read the diagnostic trouble code (DTC).

⚠ CAUTION

To prevent damage to scan tool MB991958, always turn the ignition switch to the "LOCK" (OFF) position before connecting or disconnecting scan tool MB991958.

- (1) Connect scan tool MB991958 to the data link connector.
- (2) Turn the ignition switch to the "ON" position.
- (3) Read the DTC.
- (4) Turn the ignition switch the "LOCK" (OFF) position.

Q: Is any DTC set?

YES : Refer to Diagnostic Trouble Code Chart [P.13A-44](#).

NO : Go to Step 2.

STEP 2. Using scan tool MB991958, check data list.

- (1) Turn the ignition switch the "ON" position.
- (2) Check the following items in the data list. Refer to Data List Reference Table [P.13A-852](#).
 - a. Item 1: Power Supply Voltage.
 - b. Item 6: Engine Coolant Temperature Sensor.
- (3) Turn the ignition switch the "LOCK" (OFF) position.

Q: Is the sensor operating properly?

YES : Go to Step 3.

NO : Repair or replace. Then confirm that the malfunction symptom is eliminated.

STEP 3. Using scan tool MB991958, check actuator test.

- (1) Turn the ignition switch to the "ON" position.
- (2) Check the following items in the actuator test. Refer to Actuator Test Reference Table [P.13A-871](#).
 - a. Item 9: Fuel Pump.
- (3) Turn the ignition switch to the "LOCK" (OFF) position.

Q: Is the actuator operating properly?

YES : Go to Step 4.

NO : Repair or replace. Then confirm that the malfunction symptom is eliminated.

STEP 4. Check the ignition timing.

Refer to GROUP 11A, On-vehicle Service –Ignition Timing
Check [P.11A-10](#).

Q: Is the ignition timing normal?

YES : Go to Step 5.

NO : Repair or replace. Then confirm that the malfunction symptom is eliminated.

STEP 5. Check the fuel pressure.

Refer to Fuel Pressure Test [P.13A-897](#).

Q: Is the fuel pressure normal?

YES : Go to Step 6.

NO : Repair or replace. Then confirm that the malfunction symptom is eliminated.

STEP 6. Check harness connector B-101, B-102, B-103, B-104 at injector for damage.

Q: Is the harness connector in good condition?

YES : Go to Step 7.

NO : Repair or replace it. Refer to GROUP 00E, Harness Connector Inspection [P.00E-2](#). Then confirm that the malfunction symptom is eliminated.

STEP 7. Check the injector resistance.

- (1) Disconnect the left bank injector connector B-101, B-102, B-103, B-104.
- (2) Measure the resistance between each injector side connector terminal No. 1 and No. 2.

Standard value: 10.5 –13.5 Ω [at 20° C (68° F)]

Q: Is the measured resistance between 10.5 and 13.5 ohms [at 20° C (68° F)]?

YES : Go to Step 8.

NO : Replace the faulty injector. Then confirm that the malfunction symptom is eliminated.

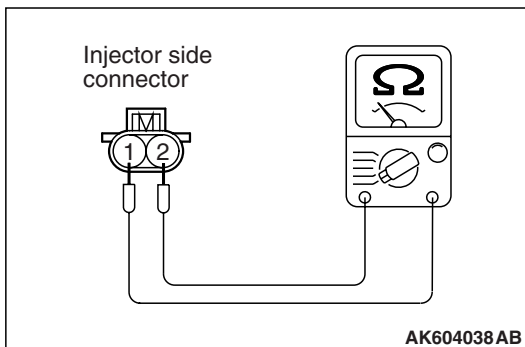

STEP 8. Check harness connector A-25X at injector relay for damage.

Q: Is the harness connector in good condition?

YES : Go to Step 9.

NO : Repair or replace it. Refer to GROUP 00E, Harness Connector Inspection [P.00E-2](#). Then confirm that the malfunction symptom is eliminated.

STEP 9. Check for harness damage between injector relay connector and injector connector.

NOTE: Check harness after checking intermediate connector A-39. If intermediate connector is damaged, repair or replace it. Refer to GROUP 00E, Harness Connector Inspection P.00E-2. Then confirm that the malfunction symptom is eliminated.

- a. Injector relay connector A-25X (terminal No. 3) and No. 1 cylinder injector connector B-101 (terminal No. 1).
- b. Injector relay connector A-25X (terminal No. 3) and No. 2 cylinder injector connector B-102 (terminal No. 1).
- c. Injector relay connector A-25X (terminal No. 3) and No. 3 cylinder injector connector B-103 (terminal No. 1).
- d. Injector relay connector A-25X (terminal No. 3) and No. 4 cylinder injector connector B-104 (terminal No. 1).

Q: Is the harness wire in good condition?

YES : Go to Step 10.

NO : Repair it. Then confirm that the malfunction symptom is eliminated.

STEP 10. Check harness connector B-09 at ECM for damage.**Q: Is the harness connector in good condition?**

YES : Go to Step 11.

NO : Repair or replace it. Refer to GROUP 00E, Harness Connector Inspection P.00E-2. Then confirm that the malfunction symptom is eliminated.

STEP 11. Check for open circuit and short circuit to ground and harness damage between injector connector and ECM connector.

- a. No. 1 cylinder injector connector B-101 (terminal No. 2) and ECM connector B-09 (terminal No. 2).
- b. No. 2 cylinder injector connector B-102 (terminal No. 2) and ECM connector B-09 (terminal No. 3).
- c. No. 3 cylinder injector connector B-103 (terminal No. 2) and ECM connector B-09 (terminal No. 18).
- d. No. 4 cylinder injector connector B-104 (terminal No. 2) and ECM connector B-09 (terminal No. 19).

Q: Is the harness wire in good condition?

YES : Go to Step 12.

NO : Repair it. Then confirm that the malfunction symptom is eliminated.

STEP 12. Check the ignition system.

- (1) Connect the timing light to terminal No. 4 of the ignition coil connector B-02, B-03, B-04 or B-06 in order.
- (2) Crank the engine.
 - The timing light flashes.
- (3) Turn the ignition switch to the "LOCK" (OFF) position.

Q: Does the timing light flash?

YES : Go to Step 13.

NO : Refer to Inspection procedure 25 –Ignition circuit system [P.13A-842](#).

STEP 13. Check the spark plugs.

Refer to GROUP 16, Ignition System –On-vehicle Service – Spark Plug Check And Cleaning [P.16-37](#).

Q: Are there any abnormalities?

YES : Replace the spark plug. Then confirm that the malfunction symptom is eliminated.

NO : Go to Step 14.

STEP 14. Check the ignition coil.

Refer to GROUP 16, Ignition System –On-vehicle Service – Ignition Coil Check [P.16-36](#).

Q: Are there any abnormalities?

YES : Replace the ignition coil. Then confirm that the malfunction symptom is eliminated.

NO : Go to Step 15.

STEP 15. Check the compression pressure.

Refer to GROUP 11A, On-vehicle Service –Compression Pressure Check [P.11A-15](#).

Q: Is the compression pressure normal?

YES : Check the following items, and repair or replace the defective items.

- a. Check if fuel is contaminated.
- b. Check if the injectors are clogged.

Then confirm that the malfunction symptom is eliminated.

NO : Repair it. Then confirm that the malfunction symptom is eliminated.

Inspection procedure 7: Unstable idle (rough idle, hunting)**COMMENT**

- In cases such as the above, the cause is probably the air/fuel mixture. Other systems affecting idle quality include the ignition system and compression.

TROUBLESHOOTING HINTS (The most likely causes for this case:)

- Malfunction of the fuel pump system.
- Malfunction of the ignition system.
- Malfunction of the injector system.
- Poor compression
- Malfunction of the purge control system
- Improper operation of the PCV valve.
- Malfunction of the charging system.
- Vacuum leak.
- Contaminated fuel.
- Malfunction of variable valve timing control (MIVEC) system.
- Malfunction of the ECM.

DIAGNOSIS**Required Special Tools:**

- MB991958: Scan Tool (M.U.T.-III Sub Assembly)
 - MB991824: V.C.I.
 - MB991827: USB Cable
 - MB991910: Main Harness A
- MB992110: Power Plant ECU Check Harness

STEP 1. Using scan tool MB991958, read the diagnostic trouble code (DTC)**⚠ CAUTION**

To prevent damage to scan tool MB991958, always turn the ignition switch to the "LOCK" (OFF) position before connecting or disconnecting scan tool MB991958.

- (1) Connect scan tool MB991958 to the data link connector.
- (2) Turn the ignition switch to the "ON" position.
- (3) Read the DTC.
- (4) Turn the ignition switch to the "LOCK" (OFF) position.

Q: Is any DTC set?

YES : Refer to Diagnostic Trouble Code Chart [P.13A-44](#).

NO : Go to Step 2.

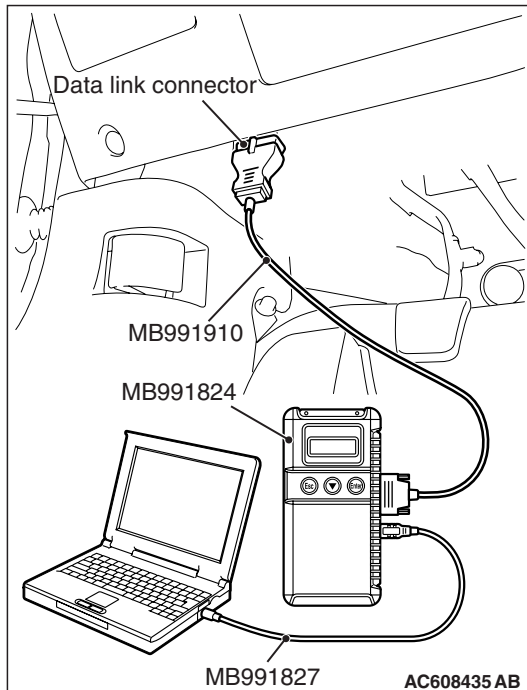

STEP 2. Using scan tool MB991958, check actuator test.

- (1) Turn the ignition switch to the "ON" position.
- (2) Check following items in the actuator test. Refer to Actuator Test Reference Table [P.13A-871](#).
 - a. Item 1: Injector.
 - b. Item 10: Evaporative emission purge solenoid
- (3) Turn the ignition switch to the "LOCK" (OFF) position.

Q: Are they operating properly?

YES : Go to Step 3.

NO : Repair or replace it. Then confirm that the malfunction symptom is eliminated.

STEP 3. Using scan tool MB991958, check data list.

- (1) Turn the ignition switch to the "ON" position.
- (2) Check the following items in the data list. Refer to Data List Reference Table [P.13A-852](#).
 - a. Item 5: Intake Air Temperature Sensor.
 - b. Item 6: Engine Coolant Temperature Sensor.
 - c. Item 10: Mass Airflow Sensor
 - d. Item 36: Intake V.V.T. phase angle
 - e. Item 39: Exhaust V.V.T. phase angle
 - f. Item 76: A/C Switch
- (3) Turn the ignition switch to the "LOCK" (OFF) position.

Q: Are they operating properly?

YES : Go to Step 4.

NO : Repair or replace it. Then confirm that the malfunction symptom is eliminated.

STEP 4. Check the fuel pressure.

Refer to Fuel Pressure Test [P.13A-897](#).

Q: Is the fuel pressure normal?

YES : Go to Step 5.

NO : Repair or replace it. Then confirm that the malfunction symptom is eliminated.

STEP 5. Check the ignition timing.

Refer to GROUP 11A, On-vehicle Service –Ignition Timing Check [P.11A-10](#).

Q: Is the ignition timing normal?

YES : Go to Step 6.

NO : Check for installed conditions of the timing chain. Then confirm that the malfunction symptom is eliminated.

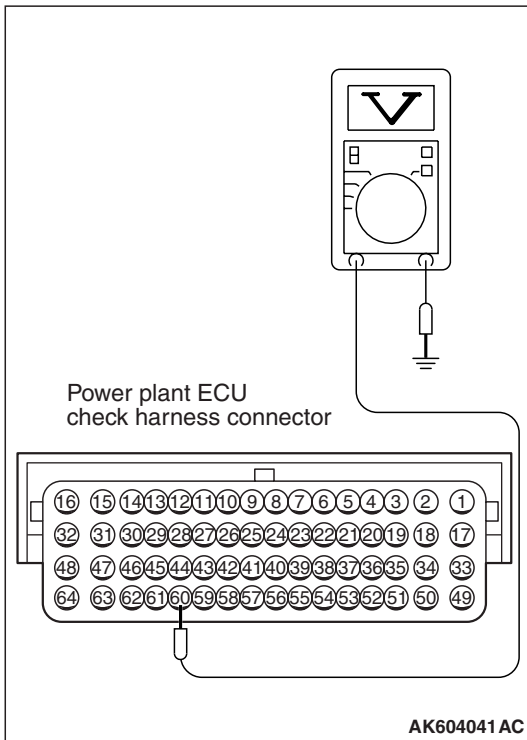
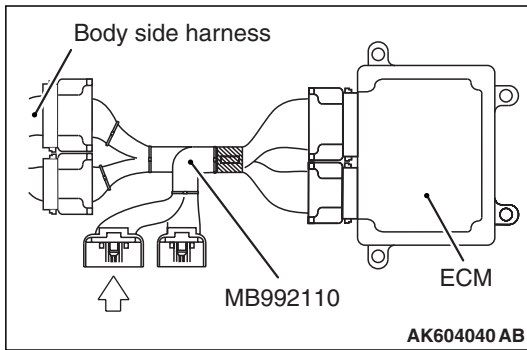

STEP 6. Measure the voltage at ECM connector B-09 by using check harness special tool MB992110.

- (1) Disconnect all ECM connectors. Connect the check harness special tool MB992110 between the separated connectors.
- (2) Start the engine and run at idle.
NOTE: Vehicles for Canada, the headlight, taillight, etc. remain lit even when the lighting switch is in "OFF" position but this is no problem for checks.

- (3) Measure the voltage between terminal No. 60 and ground.
 - a. Engine: warming up, idling
 - b. Radiator fan: stopped
 - c. Headlight: OFF to ON
 - d. Stop light: OFF to ON
 - e. Rear defogger switch: OFF to ON
 - Voltage increases
- (4) Turn the ignition switch to the "LOCK" (OFF) position.

Q: Is the harness measured voltage within the specified range?

YES : Go to Step 7.

NO : Replace the generator. Then confirm that the malfunction symptom is eliminated.

STEP 7. Check the spark plugs.

Refer to GROUP 16, Ignition System –On-vehicle Service – Spark Plug Check And Cleaning [P.16-37](#).

Q: Are there any abnormalities?

YES : Replace the spark plug. Then confirm that the malfunction symptom is eliminated.

NO : Go to Step 8.

STEP 8. Check the ignition coil.

Refer to GROUP 16, Ignition System –On-vehicle Service – Ignition Coil Check And Cleaning [P.16-36](#).

Q: Are there any abnormalities?

YES : Replace the ignition coil. Then confirm that the malfunction symptom is eliminated.

NO : Go to Step 9.

STEP 9. Check the compression pressure.

Refer to GROUP 11A, On-vehicle Service –Compression Pressure Check [P.11A-15](#).

Q: Is the compression pressure normal?

YES : Go to Step 10.

NO : Repair it. Then confirm that the malfunction symptom is eliminated.

STEP 10. Check the positive crankcase ventilation system.

Refer to GROUP 17, Emission Control System –Positive Crankcase Ventilation System –Positive Crankcase Ventilation System Check [P.17-73](#).

Q: Is the positive crankcase ventilation system?

YES : Go to Step 11.

NO : Repair it. Then confirm that the malfunction symptom is eliminated.

STEP 11. Check the purge control system.

Refer to GROUP 17, Emission Control System –Evaporative Emission Control System –Purge Control System Check (Purge Flow Check) [P.17-76](#).

Q: Is the purge control system normal?

YES : Check the following items, and repair or replace the defective items.

1. Vacuum leak.
2. Check if fuel is contaminated.
3. Check if the injectors are clogged.

Then confirm that the malfunction symptom is eliminated.

NO : Repair it. Then confirm that the malfunction symptom is eliminated.

Inspection procedure 8: Idle speed is high (improper idle speed)**COMMENT**

- In such cases as the above, the cause is probably that the intake air volume during idle is too great.

TROUBLESHOOTING HINTS (The most likely causes for this case:)

- Malfunction of the engine coolant temperature sensor signal.

- Malfunction of the accelerator pedal position sensor (main) signal.
- Malfunction of the accelerator pedal position sensor (sub) signal.
- Malfunction of the A/C switch signal.
- Malfunction of the power steering pressure switch signal.
- Malfunction of the evaporative emission control system.
- Malfunction of the ECM.

DIAGNOSIS**Required Special Tools:**

- MB991958: Scan Tool (M.U.T.-III Sub Assembly)
 - MB991824: V.C.I.
 - MB991827: USB Cable
 - MB991910: Main Harness A

STEP 1. Using scan tool MB991958, read the diagnostic trouble code (DTC).**⚠ CAUTION**

To prevent damage to scan tool MB991958, always turn the ignition switch to the "LOCK" (OFF) position before connecting or disconnecting scan tool MB991958.

- (1) Connect scan tool MB991958 to the data link connector.
- (2) Turn the ignition switch to the "ON" position.
- (3) Read the DTC.
- (4) Turn the ignition switch to the "LOCK" (OFF) position.

Q: Is any DTC set?

- YES** : Refer to Diagnostic Trouble Code Chart [P.13A-44](#).
NO : Go to Step 2.

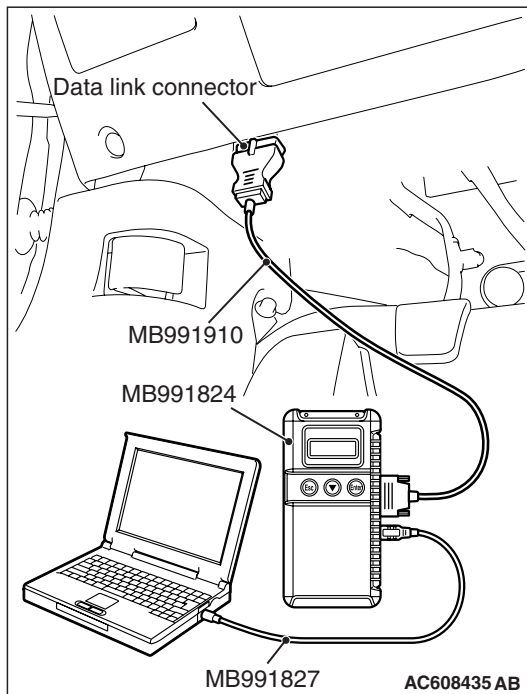

STEP 2. Using scan tool MB991958, check data list.

- (1) Turn the ignition switch to the "ON" position.
- (2) Check the following item in the data list. Refer to Data List Reference Table [P.13A-852](#).
 - a. Item 6: Engine Coolant Temperature Sensor.
 - b. Item 11: Accelerator pedal position sensor (main)
 - c. Item 12: Accelerator pedal position sensor (sub)
 - d. Item 76: A/C switch
 - e. Item 83: Power steering pressure switch
- (3) Turn the ignition switch to the "LOCK" (OFF) position.

Q: Is the sensor operating properly?

YES : Refer to GROUP 17, Emission Control System – Evaporative Emission Control System –Evaporative Emission Purge Solenoid Check [P.17-77](#).

NO : Repair or replace it. Then confirm that the malfunction symptom is eliminated.

Inspection procedure 9: Idle speed is low (improper idle speed)

COMMENT

- In cases such as the above, the cause is probably that the intake air volume during idle is too small.

TROUBLESHOOTING HINTS (The most likely causes for this case:)

- Malfunction of the engine coolant temperature sensor signal.
- Malfunction of the torque converter.
- Dirtiness around throttle valve.
- Malfunction of the ECM.

DIAGNOSIS

Required Special Tools:

- MB991958: Scan Tool (M.U.T.-III Sub Assembly)
 - MB991824: V.C.I.
 - MB991827: USB Cable
 - MB991910: Main Harness A

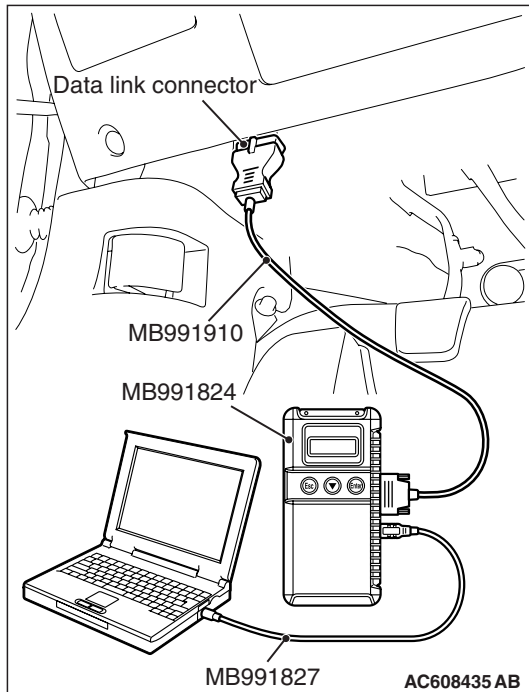

STEP 1. Using scan tool MB991958, read the diagnostic trouble code (DTC).

⚠ CAUTION

To prevent damage to scan tool MB991958, always turn the ignition switch to the "LOCK" (OFF) position before connecting or disconnecting scan tool MB991958.

- (1) Connect scan tool MB991958 to the data link connector.
- (2) Turn the ignition switch to the "ON" position.
- (3) Read the DTC.
- (4) Turn the ignition switch to the "LOCK" (OFF) position.

Q: Is any DTC set?

YES : Refer to Diagnostic Trouble Code Chart [P.13A-44](#).

NO : Check the following item in the data list. Refer to Data List Reference Table [P.13A-852](#).

- a. Item 6: Engine Coolant Temperature Sensor

Then confirm that the malfunction symptom is eliminated.

Inspection procedure 10: When the engine is cold, it stalls at idle (die out)

COMMENT

- In such cases as the above, the air/fuel mixture may be inappropriate when the engine is cold.

TROUBLESHOOTING HINTS (The most likely causes for this case:)

- Malfunction of the fuel pump system.
- Malfunction of the ignition system.
- Poor compression.
- Improper engine oil viscosity.
- Malfunction of the ECM.

DIAGNOSIS

Required Special Tools:

- MB991958: Scan Tool (M.U.T.-III Sub Assembly)
 - MB991824: V.C.I.
 - MB991827: USB Cable
 - MB991910: Main Harness A

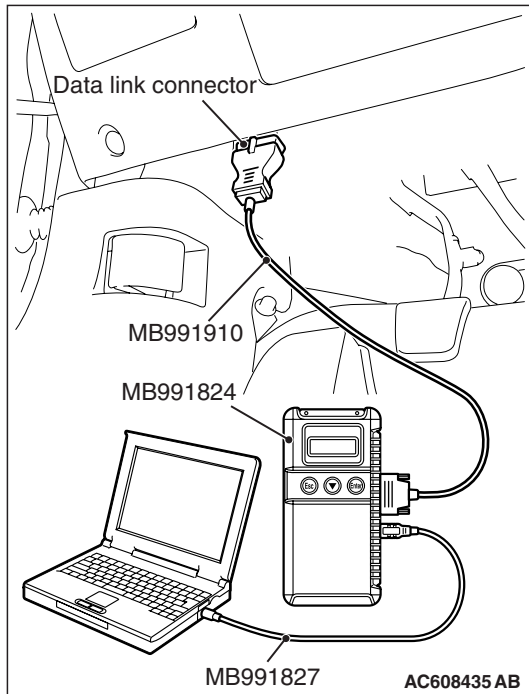

STEP 1. Using scan tool MB991958, read the diagnostic trouble code (DTC).

⚠ CAUTION

To prevent damage to scan tool MB991958, always turn the ignition switch to the "LOCK" (OFF) position before connecting or disconnecting scan tool MB991958.

- (1) Connect scan tool MB991958 to the data link connector.
- (2) Turn the ignition switch to the "ON" position.
- (3) Read the DTC.
- (4) Turn the ignition switch to the "LOCK" (OFF) position.

Q: Is any DTC set?

YES : Refer to Diagnostic Trouble Code Chart [P.13A-44](#).

NO : Go to Step 2.

STEP 2. Using scan tool MB991958, check actuator test.

- (1) Turn the ignition switch to the "ON" position.
- (2) Check following items in the actuator test. Refer to Actuator Test Reference Table [P.13A-871](#).
 - a. Item 1: Injector.
- (3) Turn the ignition switch to the "LOCK" (OFF) position.

Q: Are they operating properly?

YES : Go to Step 3.

NO : Repair or replace it. Then confirm that the malfunction symptom is eliminated.

STEP 3. Using scan tool MB991958, check data list.

- (1) Turn the ignition switch to the "ON" position.
- (2) Check the following items in the data list. Refer to Data List Reference Table [P.13A-852](#).
 - a. Item 6: Engine Coolant Temperature Sensor.
- (3) Turn the ignition switch to the "LOCK" (OFF) position.

Q: Is the sensor operating properly?

YES : Go to Step 4.

NO : Repair or replace it. Then confirm that the malfunction symptom is eliminated.

STEP 4. Check the ignition timing.

Refer to GROUP 11A, On-vehicle Service –Ignition Timing Check [P.11A-10](#).

Q: Is the ignition timing normal?

YES : Go to Step 5.

NO : Check for installed conditions of the timing chain. Then confirm that the malfunction symptom is eliminated.

STEP 5. Check the fuel pressure.

Refer to Fuel Pressure Test [P.13A-897](#).

Q: Is the fuel pressure normal?

YES : Go to Step 6.

NO : Repair or replace it. Then confirm that the malfunction symptom is eliminated.

STEP 6. Check the spark plugs.

Refer to GROUP 16, Ignition System –On-vehicle Service – Spark Plug Check And Cleaning [P.16-37](#).

Q: Are there any abnormalities?

YES : Replace the spark plug. Then confirm that the malfunction symptom is eliminated.

NO : Go to Step 7.

STEP 7. Check the ignition coil.

Refer to GROUP 16, Ignition System –On-vehicle Service – Ignition Coil Check [P.16-36](#).

Q: Are there any abnormalities?

YES : Replace the ignition coil. Then confirm that the malfunction symptom is eliminated.

NO : Go to Step 8.

STEP 8. Check the compression pressure.

Refer to GROUP 11A, On-vehicle Service –Compression Pressure Check [P.11A-15](#).

Q: Is the compression pressure normal?

YES : Check the engine oil viscosity, and replace the engine oil.

Then confirm that the malfunction symptom is eliminated.

NO : Repair it. Then confirm that the malfunction symptom is eliminated.

Inspection procedure 11: When the engine is hot, it stalls at idle (die out)

COMMENT

- In cases such as the above, the ignition system, air/fuel mixture or compression pressure may be faulty. In addition, if the engine suddenly stalls, the cause may also be a connector damage.

TROUBLESHOOTING HINTS (The most likely causes for this case:)

- Malfunction of the fuel pump system.
- Malfunction of the ignition system.
- Poor compression
- Improper operation of the PCV valve.
- Vacuum leak.
- Dirtiness around throttle valve.
- Malfunction of the ECM.

DIAGNOSIS

Required Special Tools:

- MB991958: Scan Tool (M.U.T.-III Sub Assembly)
 - MB991824: V.C.I.
 - MB991827: USB Cable
 - MB991910: Main Harness A

STEP 1. Using scan tool MB991958, read the diagnostic trouble code (DTC).

⚠ CAUTION

To prevent damage to scan tool MB991958, always turn the ignition switch to the "LOCK" (OFF) position before connecting or disconnecting scan tool MB991958.

- (1) Connect scan tool MB991958 to the data link connector.
- (2) Turn the ignition switch to the "ON" position.
- (3) Read the DTC.
- (4) Turn the ignition switch to the "LOCK" (OFF) position.

Q: Is any DTC set?

- YES** : Refer to Diagnostic Trouble Code Chart [P.13A-44](#).
NO : Go to Step 2.

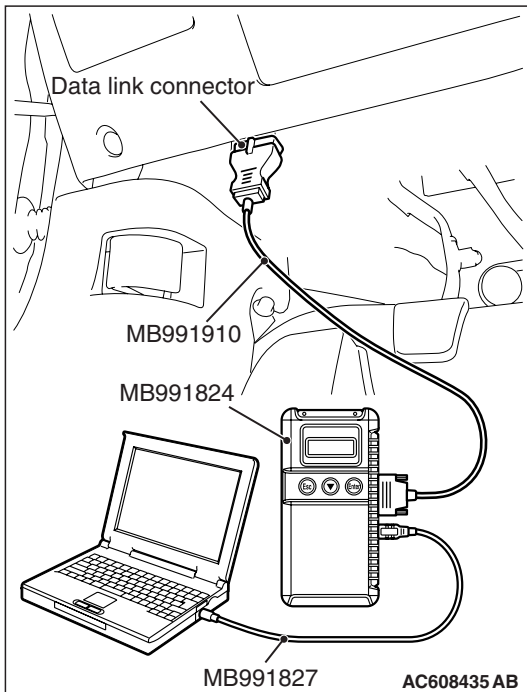

STEP 2. Using scan tool MB991958, check actuator test item 1: injector.

- (1) Turn the ignition switch to the "ON" position.
- (2) Check following items in the actuator test. Refer to Actuator Test Reference Table [P.13A-871](#).
 - a. Item 1: Injector.
- (3) Turn the ignition switch to the "LOCK" (OFF) position.

Q: Are they operating properly?**YES** : Go to Step 3.**NO** : Repair or replace it. Then confirm that the malfunction symptom is eliminated.

STEP 3. Using scan tool MB991958, check data list.

- (1) Turn the ignition switch to the "ON" position.
- (2) Check the following items in the data list. Refer to Data List Reference Table [P.13A-852](#).
 - a. Item 5: Intake Air Temperature Sensor.
 - b. Item 6: Engine Coolant Temperature Sensor.
 - c. Item 13: Throttle position sensor (main).
- (3) Turn the ignition switch to the "LOCK" (OFF) position.

Q: Are they operating properly?**YES** : Go to Step 4.**NO** : Repair or replace it. Then confirm that the malfunction symptom is eliminated.

STEP 4. Inspection of throttle body (throttle valve area) for dirtiness.**Q: Is the throttle valve area dirty?****YES** : Refer to On-vehicle Service –Throttle Body (Throttle Valve Area) Cleaning [P.13A-897](#).**NO** : Go to Step 5.

STEP 5. Check the fuel pressure.Refer to Fuel Pressure Test [P.13A-897](#).**Q: Is the fuel pressure normal?****YES** : Go to Step 6.**NO** : Repair or replace it. Then confirm that the malfunction symptom is eliminated.

STEP 6. Check the ignition timing.Refer to GROUP 11A, On-vehicle Service –Ignition Timing Check [P.11A-10](#).**Q: Is the ignition timing normal?****YES** : Go to Step 7.**NO** : Check for installed conditions of the timing chain. Then confirm that the malfunction symptom is eliminated.

STEP 7. Check the spark plugs.

Refer to GROUP 16, Ignition System –On-vehicle Service – Spark Plug Check And Cleaning [P.16-37](#).

Q: Are there any abnormalities?

YES : Replace the spark plug. Then confirm that the malfunction symptom is eliminated.

NO : Go to Step 8.

STEP 8. Check the ignition coil.

Refer to GROUP 16, Ignition System –On-vehicle Service – Ignition Coil Check [P.16-36](#).

Q: Are there any abnormalities?

YES : Replace the ignition coil. Then confirm that the malfunction symptom is eliminated.

NO : Go to Step 9.

STEP 9. Check the compression pressure.

Refer to GROUP 11A, On-vehicle Service –Compression Pressure Check [P.11A-15](#).

Q: Is the compression pressure normal?

YES : Go to Step 10.

NO : Repair it. Then confirm that the malfunction symptom is eliminated.

STEP 10. Check the positive crankcase ventilation system.

Refer to GROUP 17, Emission Control –Positive Crankcase Ventilation System –Positive Crankcase Ventilation System Check [P.17-73](#).

Q: Is the positive crankcase ventilation system?

YES : Go to Step 11.

NO : Repair it. Then confirm that the malfunction symptom is eliminated.

STEP 11. Engine stall reproduction test.**Q: Is it easy to reproduce the engine stall?**

YES : Check the following items, and repair or replace the defective items.

- a. Vacuum leak.
- b. Check if fuel is contaminated.
- c. Check if the injectors are clogged.
- d. Check if the foreign materials (water, kerosene, etc.) got into fuel.

Then confirm that the malfunction symptom is eliminated.

NO : Check if the following signals change suddenly by wiggling the circuit harness and connectors.

- a. Crankshaft position sensor signal.
- b. Mass airflow sensor signal.
- c. Injector drive signal.
- d. Primary and secondary ignition signal.
- e. Fuel pump drive signal.
- f. ECM power supply voltage.

Then confirm that the malfunction symptom is eliminated.

Inspection procedure 12: The engine stalls accelerating (pass out)

COMMENT

- In case such as the above, the cause is probably misfiring due to a weak spark, or an inappropriate air/fuel mixture when the accelerator pedal is depressed.

TROUBLESHOOTING HINTS (The most likely causes for this case:)

- Malfunction of the ignition system.
- Malfunction of the evaporative emission control system.
- Improper operation of the PCV valve.
- Vacuum leak.
- Malfunction of the ECM.

DIAGNOSIS**Required Special Tools:**

- MB991958: Scan Tool (M.U.T.-III Sub Assembly)
 - MB991824: V.C.I.
 - MB991827: USB Cable
 - MB991910: Main Harness A

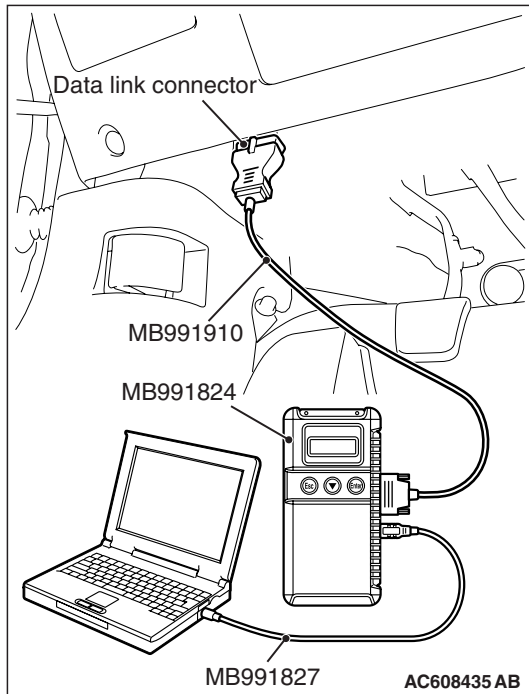

STEP 1. Using scan tool MB991958, read the diagnostic trouble code (DTC).

⚠ CAUTION

To prevent damage to scan tool MB991958, always turn the ignition switch to the "LOCK" (OFF) position before connecting or disconnecting scan tool MB991958.

- (1) Connect scan tool MB991958 to the data link connector.
- (2) Turn the ignition switch to the "ON" position.
- (3) Read the DTC.
- (4) Turn the ignition switch to the "LOCK" (OFF) position.

Q: Is any DTC set?

- YES :** Refer to Diagnostic Trouble Code Chart [P.13A-44](#).
NO : Go to Step 2.

STEP 2. Using scan tool MB991958, check actuator test.

- (1) Turn the ignition switch to the "ON" position.
- (2) Check the following item in the actuator test. Refer to Actuator Test Reference Table [P.13A-871](#).
 - a. Item 10: Evaporative Emission Purge Solenoid.
- (3) Turn the ignition switch to the "LOCK" (OFF) position.

Q: Is the actuator operating properly?

- YES :** Go to Step 3.
NO : Repair or replace it. Then confirm that the malfunction symptom is eliminated.

STEP 3. Check the spark plugs.

Refer to GROUP 16, Ignition System –On-vehicle Service – Spark Plug Check And Cleaning [P.16-37](#).

Q: Are there any abnormalities?

- YES :** Replace the spark plug. Then confirm that the malfunction symptom is eliminated.
NO : Go to Step 4.

STEP 4. Check the ignition coil.

Refer to GROUP 16, Ignition System –On-vehicle Service – Ignition Coil Check [P.16-36](#).

Q: Are there any abnormalities?

- YES :** Replace the ignition coil. Then confirm that the malfunction symptom is eliminated.
NO : Go to Step 5.

STEP 5. Check the positive crankcase ventilation system.

Refer to GROUP 17, Emission Control –Positive Crankcase Ventilation System –Positive Crankcase Ventilation System
Check [P.17-73](#).

Q: Is the positive crankcase ventilation system?

YES : Check the following items, and repair or replace the defective items.

- a. Vacuum leak.

Then confirm that the malfunction symptom is eliminated.

NO : Repair it. Then confirm that the malfunction symptom is eliminated.

Inspection procedure 13: The engine stalls decelerating

COMMENT

- The abnormal air/fuel ratio or other similar defects can possibly be caused by the insufficient intake air volume.

TROUBLESHOOTING HINTS (The most likely causes for this case:)

- Malfunction of the ignition system.
- Dirtiness around throttle valve.
- Malfunction of the ECM.

DIAGNOSIS**Required Special Tools:**

- MB991958: Scan Tool (M.U.T.-III Sub Assembly)
 - MB991824: V.C.I.
 - MB991827: USB Cable
 - MB991910: Main Harness A

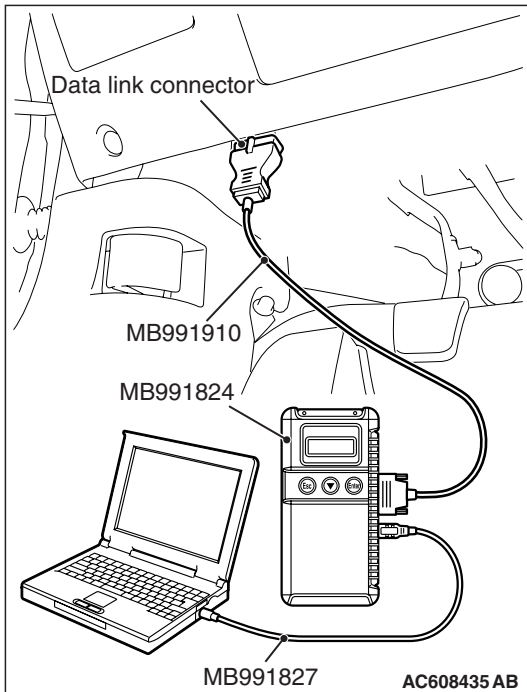

STEP 1. Using scan tool MB991958, read the diagnostic trouble code (DTC).

⚠ CAUTION

To prevent damage to scan tool MB991958, always turn the ignition switch to the "LOCK" (OFF) position before connecting or disconnecting scan tool MB991958.

- (1) Connect scan tool MB991958 to the data link connector.
- (2) Turn the ignition switch to the "ON" position.
- (3) Read the DTC.
- (4) Turn the ignition switch to the "LOCK" (OFF) position.

Q: Is any DTC set?

YES : Refer to Diagnostic Trouble Code Chart [P.13A-44](#).

NO : Go to Step 2.

STEP 2. Inspection of throttle body (throttle valve area) for dirtiness.

Q: Is the throttle valve area dirty?

YES : Refer to Throttle Body (Throttle Valve Area) Cleaning [P.13A-897](#).

NO : Go to Step 3.

STEP 3. Using scan tool MB991958, check data list.

- (1) Turn the ignition switch to the "ON" position.
- (2) Check the following items in the data list. Refer to Data List Reference Table [P.13A-852](#).
 - a. Item 11: Accelerator Pedal Position Sensor (main).
 - b. Item 12: Accelerator Pedal Position Sensor (sub).
 - c. Item 13: Throttle Position Sensor (main).
 - d. Item 15: Throttle Position Sensor (sub).
- (3) Turn the ignition switch to the "LOCK" (OFF) position.

Q: Are they operating properly?

YES : Go to Step 4.

NO : Repair or replace it. Then confirm that the malfunction symptom is eliminated.

STEP 4. Check the spark plugs.

Refer to GROUP 16, Ignition System –On-vehicle Service – Spark Plug Check [P.16-37](#).

Q: Are there any abnormalities?

YES : Replace the spark plug. Then confirm that the malfunction symptom is eliminated.

NO : Check the ignition coil (Refer to GROUP 16, Ignition System –On-vehicle Service –Ignition Coil Check [P.16-36](#)). Then confirm that the malfunction symptom is eliminated.

Inspection procedure 14: Hesitation, sag, stumble, poor acceleration or surge**COMMENT**

- Defective ignition system, abnormal air/fuel ratio, poor compression pressure, etc. are suspected.

TROUBLESHOOTING HINTS (The most likely causes for this case:)

- Malfunction of the fuel pump system.

- Malfunction of the ignition system.
- Poor compression.
- Improper operation of the PCV valve.
- Vacuum leak.
- Clogged air cleaner.
- Clogged exhaust system.
- Malfunction of the TC-SST system.
- Malfunction of the ECM.

DIAGNOSIS**Required Special Tools:**

- MB991958: Scan tool (M.U.T.-III Sub Assembly)
 - MB991824: V.C.I.
 - MB991827: USB Cable
 - MB991910: Main Harness A

NOTE: To protect the TC-SST, the TC-SST-ECU outputs, into the ECM, the request signal to reduce the engine torque according to the operation condition. Based on the signal, the ECM closes the throttle valve, retards the ignition or carries out fuel cut. At that time, the engine output seems to temporarily reduce, but there is no malfunction.

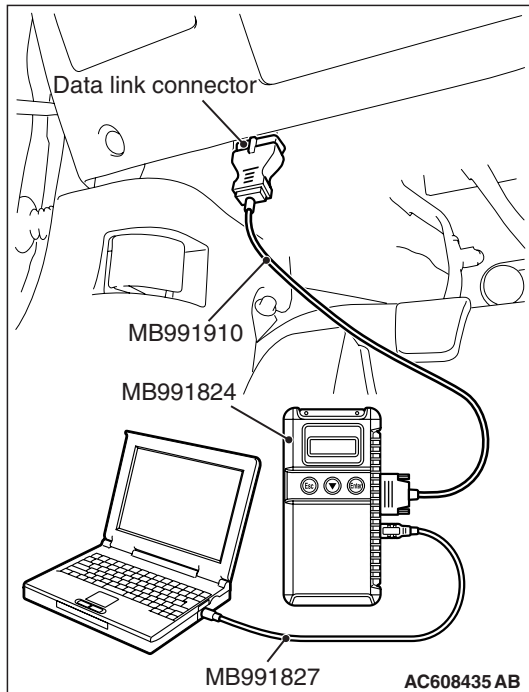

STEP 1. Using scan tool MB991958, read the diagnostic trouble code (DTC).

⚠ CAUTION

To prevent damage to scan tool MB991958, always turn the ignition switch to the "LOCK" (OFF) position before connecting or disconnecting scan tool MB991958.

- (1) Connect scan tool MB991958 to the data link connector.
- (2) Turn the ignition switch to the "ON" position.
- (3) Read the DTC.
- (4) Turn the ignition switch to the "LOCK" (OFF) position.

Q: Is any DTC set?

YES : Refer to Diagnostic Trouble Code Chart [P.13A-44](#).

NO : Go to Step 2.

STEP 2. Using scan tool MB991958, read the diagnostic trouble code (DTC).

NOTE: When the TC-SST has a malfunction, the TC-SST-ECU might output the request signal of reducing the engine torque in order to protect the TC-SST.

- (1) Turn the ignition switch to the "ON" position.
- (2) Read the TC-SST-DTC.
- (3) Turn the ignition switch to the "LOCK" (OFF) position.

Q: Is the TC-SST-DTC set?

YES : Refer to GROUP 22C, Diagnosis <TC-SST> – Diagnostic Trouble Code Chart [P.22C-10](#).

NO : Go to Step 3.

STEP 3. Using scan tool MB991958, check actuator test item 1: injector.

- (1) Turn the ignition switch to the "ON" position.
- (2) Test Reference Table [P.13A-871](#).
 - a. Item 1: Injector.
- (3) Turn the ignition switch to the "LOCK" (OFF) position.

Q: Are thy operating properly?

YES : Go to Step 4.

NO : Repair or replace it. Then confirm that the malfunction symptom is eliminated.

STEP 4. Check the ignition timing.

- (1) Refer to GROUP 11A, On-vehicle Service –Ignition Timing Check [P.11A-10](#).

Q: Is the ignition timing normal?

YES : Go to Step 5.

NO : Check for installed conditions of the timing chain. Then confirm that the malfunction symptom is eliminated.

STEP 5. Using scan tool MB991958, check data list and actuator test.

- (1) Turn the ignition switch to the "ON" position.
(2) Check the following items in the data list. Refer to Data List Reference Table [P.13A-852](#).
- Item 5: Intake Air Temperature Sensor.
 - Item 6: Engine Coolant Temperature Sensor.
 - Item 11: Accelerator Pedal Position Sensor (main).
 - Item 12: Accelerator Pedal Position Sensor (sub).
 - Item 13: Throttle Position Sensor (main).
 - Item 15: Throttle Position Sensor (sub).
- (3) Turn the ignition switch to the "LOCK" (OFF) position.

Q: Are they operating properly?

YES : Go to Step 6.

NO : Repair or replace it. Then confirm that the malfunction symptom is eliminated.

STEP 6. Check the fuel pressure.

Refer to Fuel Pressure Test [P.13A-897](#).

Q: Is the fuel pressure normal?

YES : Go to Step 7.

NO : Repair or replace it. Then confirm that the malfunction symptom is eliminated.

STEP 7. Check the spark plugs.

Refer to GROUP 16, Ignition System –On-vehicle Service – Spark Plug Check And Cleaning [P.16-37](#).

Q: Are there any abnormalities?

YES : Replace the spark plug. Then confirm that the malfunction symptom is eliminated.

NO : Go to Step 8.

STEP 8. Check the ignition coil.

Refer to GROUP 16, Ignition System –On-vehicle Service – Ignition Coil Check [P.16-36](#).

Q: Are there any abnormalities?

YES : Replace the ignition coil. Then confirm that the malfunction symptom is eliminated.

NO : Go to Step 9.

STEP 9. Check the positive crankcase ventilation system.
Refer to GROUP 17, Emission Control System –Positive Crankcase Ventilation System –Positive Crankcase Ventilation System Check [P.17-73](#).

Q: Is the positive crankcase ventilation system?

YES : Check the following items, and repair or replace the defective items.

- a. Vacuum leak.
- b. Clogged air cleaner.
- c. Clogged exhaust system.
- d. Check if fuel is contaminated.
- e. Check if the injectors are clogged.
- f. Check if the foreign materials (water, kerosene, etc.) got into fuel.

Then confirm that the malfunction symptom is eliminated.

NO : Repair it. Then confirm that the malfunction symptom is eliminated.

Inspection procedure 15: Acceleration shock

COMMENT

- There may be an ignition leak accompanying the increase in the spark plug demand voltage during acceleration.

TROUBLESHOOTING HINTS (The most likely causes for this case:)

- Malfunction of the ignition system.
- Malfunction of the TC-SST system.
- Malfunction of the ECM.

DIAGNOSIS

Required Special Tools:

- MB991958: Scan Tool (M.U.T.-III Sub Assembly)
 - MB991824: V.C.I.
 - MB991827: USB Cable
 - MB991910: Main Harness A

NOTE: To protect the TC-SST, the TC-SST-ECU outputs, into the ECM, the request signal to reduce the engine torque according to the operation condition. Based on the signal, the ECM closes the throttle valve, retards the ignition or carries out fuel cut. At that time, the engine output seems to temporarily reduce, but there is no malfunction.

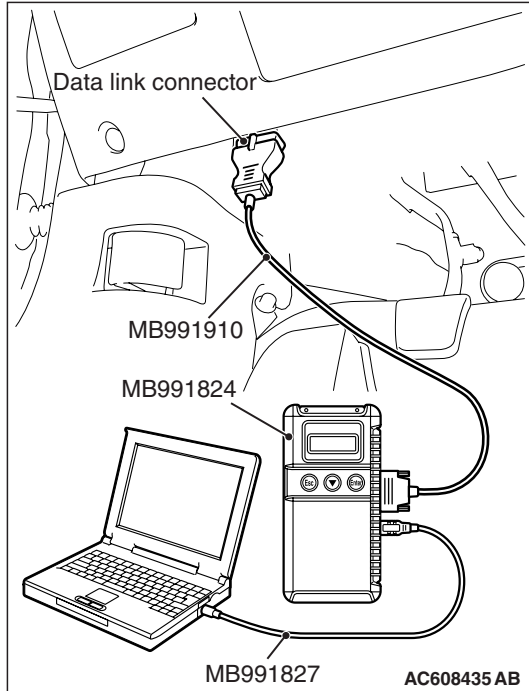

STEP 1. Using scan tool MB991958, read the diagnostic trouble code (DTC).

⚠ CAUTION

To prevent damage to scan tool MB991958, always turn the ignition switch to the "LOCK" (OFF) position before connecting or disconnecting scan tool MB991958.

- (1) Connect scan tool MB991958 to the data link connector.
- (2) Turn the ignition switch to the "ON" position.
- (3) Read the DTC.
- (4) Turn the ignition switch to the "LOCK" (OFF) position.

Q: Is any DTC set?

YES : Refer to Diagnostic Trouble Code Chart [P.13A-44](#).

NO : Go to Step 2.

STEP 2. Using scan tool MB991958, read the diagnostic trouble code (DTC).

NOTE: When the TC-SST has a malfunction, the TC-SST-ECU might output the request signal of reducing the engine torque in order to protect the TC-SST.

- (1) Turn the ignition switch to the "ON" position.
- (2) Read the TC-SST-DTC.
- (3) Turn the ignition switch to the "LOCK" (OFF) position.

Q: Is the TC-SST-DTC set?

YES : Refer to GROUP 22C, Diagnosis –Diagnostic Trouble Code Chart [P.22C-10](#).

NO : Go to Step 3 .

STEP 3. Check the spark plugs.

Refer to GROUP 16, Ignition System –On-vehicle Service – Spark Plug Check And Cleaning [P.16-37](#).

Q: Are there any abnormalities?

YES : Replace the spark plug. Then confirm that the malfunction symptom is eliminated.

NO : Go to Step 4.

STEP 4. Check the ignition coil.

Refer to GROUP 16, Ignition System –On-vehicle Service – Ignition Coil Check [P.16-36](#).

Q: Are there any abnormalities?

YES : Replace the ignition coil. Then confirm that the malfunction symptom is eliminated.

NO : Check for occurrence of ignition leak. Then confirm that the malfunction symptom is eliminated.

Inspection procedure 16: Knocking

COMMENT

- Incases such as the above, the cause is probably that the detonation control is defective or the heat value of the spark plug is inappropriate.

TROUBLESHOOTING HINTS (The most likely causes for this case:)

- Defective knock sensor.
- Incorrect heat value of the spark plug.
- Poor compression.
- Malfunction of the ECM.

DIAGNOSIS

Required Special Tools:

- MB991958: Scan Tool (M.U.T.-III Sub Assembly)
 - MB991824: V.C.I.
 - MB991827: USB Cable
 - MB991910: Main Harness A

STEP 1. Using the scan tool MB991958, read the diagnostic trouble code (DTC).

⚠ CAUTION

To prevent damage to scan tool MB991958, always turn the ignition switch to the "LOCK" (OFF) position before connecting or disconnecting scan tool MB991958.

- (1) Connect scan tool MB991958 to the data link connector.
- (2) Turn the ignition switch to the "ON" position.
- (3) Read the DTC.
- (4) Turn the ignition switch to the "LOCK" (OFF) position.

Q: Is any DTC set?

YES : Refer to Diagnostic Trouble Code Chart [P.13A-44](#).

NO : Go to Step 2.

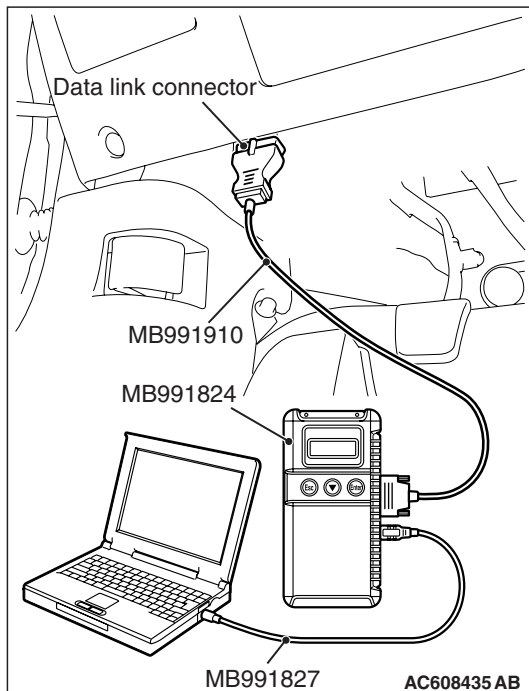

STEP 2. Using scan tool MB991958, check data list.

- (1) Turn the ignition switch to the "ON" position.
- (2) Check the following items of the data list. Refer to Data List Reference Table [P.13A-852](#).
 - a. Item 32: Knock retard.
- (3) Turn the ignition switch to the "LOCK" (OFF) position.

Q: Is the sensor operating properly?

YES : Go to Step 3.

NO : Refer to DTC P0327 –Knock Sensor Circuit Low Input [P.13A-361](#), DTC P0328 - Knock Sensor Circuit High Input [P.13A-364](#).

STEP 3. Check the spark plugs.

Refer to GROUP 16, Ignition System –On-vehicle Service – Spark Plug Check And Cleaning [P.16-37](#).

Q: Are there any abnormalities?

YES : Replace the spark plug. Then confirm that the malfunction symptom is eliminated.

NO : Go to Step 4.

STEP 4. Check the compression pressure.

Refer to GROUP 11A, On-vehicle Service –Compression Pressure Check [P.11A-15](#).

Q: Is the compression pressure normal?

YES : Check the following items, and repair or replace the defective items.

- a. Check if fuel is contaminated.
- b. Check if the foreign materials (water, kerosene, etc.) got into fuel.
- c. Check the octane level of the fuel.

Then confirm that the malfunction symptom is eliminated.

NO : Repair it. Then confirm that the malfunction symptom is eliminated.

Inspection procedure 17: Too high CO and HC concentration when idling

COMMENT

- Abnormal air/fuel ratio is suspected.

TROUBLESHOOTING HINTS (The most likely causes for this case:)

- Malfunction of the fuel pump system.

- Malfunction of the heated oxygen sensor.
- Malfunction of the ignition system.
- Poor compression.
- Improper operation of the PCV valve.
- Malfunction of the evaporative emission control system.
- Malfunction of the ECM.

DIAGNOSIS

Required Special Tools:

- MB991958: Scan Tool (M.U.T.-III Sub Assembly)
 - MB991824: V.C.I.
 - MB991827: USB Cable
 - MB991910: Main Harness A

STEP 1. Using scan tool MB991958, read the diagnostic trouble code (DTC).

⚠ CAUTION

To prevent damage to scan tool MB991958, always turn the ignition switch to the "LOCK" (OFF) position before connecting or disconnecting scan tool MB991958.

- (1) Connect scan tool MB991958 to the data link connector.
- (2) Turn the ignition switch to the "ON" position.
- (3) Read the DTC.
- (4) Turn the ignition switch to the "LOCK" (OFF) position.

Q: Is any DTC set?

- YES** : Refer to Diagnostic Trouble Code Chart [P.13A-44](#).
NO : Go to Step 2.

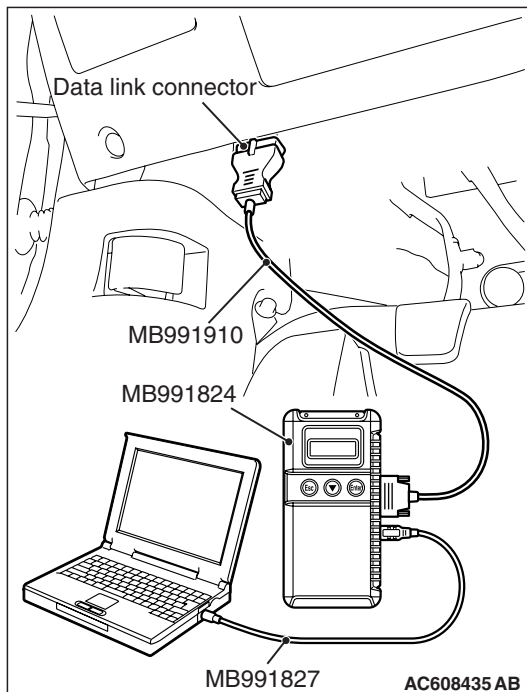

STEP 2. Check the ignition timing.

Refer to GROUP 11A, On-vehicle Service –Ignition Timing Check [P.11A-10](#).

Q: Is the ignition timing normal?

- YES** : Go to Step 3.
NO : Check for installed conditions of the timing chain. Then confirm that the malfunction symptom is eliminated.

STEP 3. Using scan tool MB991958, check data list.

- (1) Turn the ignition switch to the "ON" position.
- (2) Check the following items in the data list. Refer to Data List Reference Table [P.13A-852](#).
 - a. Item 5: Intake Air Temperature Sensor.
 - b. Item 6: Engine Coolant Temperature Sensor.
 - c. Item AC: Heated Oxygen Sensor (front).
 - d. Item AD: Heated Oxygen Sensor (rear).
- (3) Turn the ignition switch to the "LOCK" (OFF) position.

Q: Are they operating properly?**YES** : Go to Step 4.**NO** : Repair or replace it. Then confirm that the malfunction symptom is eliminated.

STEP 4. Check the fuel pressure.Refer to Fuel Pressure Test [P.13A-897](#).**Q: Is the fuel pressure normal?****YES** : Go to Step 5.**NO** : Repair or replace it. Then confirm that the malfunction symptom is eliminated.

STEP 5. Check the spark plugs.Refer to GROUP 16, Ignition System –On-vehicle Service – Spark Plug Check And Cleaning [P.16-37](#).**Q: Are there any abnormalities?****YES** : Replace the spark plug. Then confirm that the malfunction symptom is eliminated.**NO** : Go to Step 6.

STEP 6. Check the ignition coil.Refer to GROUP 16, Ignition System –On-vehicle Service – Ignition Coil Check [P.16-36](#).**Q: Are there any abnormalities?****YES** : Replace the ignition coil. Then confirm that the malfunction symptom is eliminated.**NO** : Go to Step 7.

STEP 7. Check the compression pressure.Refer to GROUP 11A, On-vehicle Service –Compression Pressure Check [P.11A-15](#).**Q: Is the compression pressure normal?****YES** : Go to Step 8.**NO** : Repair it. Then confirm that the malfunction symptom is eliminated.

STEP 8. Check the positive crankcase ventilation system.
Refer to GROUP 17, Emission Control –Positive Crankcase Ventilation System –Positive Crankcase Ventilation System
Check [P.17-73](#).

Q: Is the positive crankcase ventilation system?

YES : Go to Step 9.

NO : Repair it. Then confirm that the malfunction symptom is eliminated.

STEP 9. Check the evaporative emission control system.
Refer to GROUP 17, Emission Control –Evaporative Emission Control System –Purge Control System Check (Purge Flow Check) [P.17-76](#).

Q: Is the purge control system normal?

YES : Check the following items, and repair or replace the defective items.

a. Check if the injectors are clogged.

Then confirm that the malfunction symptom is eliminated.

NO : Repair it. Then confirm that the malfunction symptom is eliminated.

Inspection procedure 18: Transient, mass emission tailpipe test failure

COMMENT

- The test is failed when the air/fuel ratio is not controlled to the ideal air/fuel ratio. This occurs due to the feedback control by heated oxygen sensor signals, or deteriorated catalyst.

NOTE: If the three-way catalyst temperature is low when checking the exhaust gas, the three-way catalyst cannot sufficiently clean the emissions. Warm up the engine sufficiently before checking the exhaust, and check immediately.

TROUBLESHOOTING HINTS (The most likely causes for this case:)

- Malfunction of air/fuel ratio control system.
- Malfunction of the fuel pump system.
- Malfunction of the ignition system.
- Poor compression.
- Improper operation of the PCV valve
- Malfunction of the evaporative emission control system
- Deteriorated catalyst.

DIAGNOSIS

Required Special Tools:

- MB991958: Scan Tool (M.U.T.-III Sub Assembly)
 - MB991824: V.C.I.
 - MB991827: USB Cable
 - MB991910: Main Harness A

STEP 1. Check the exhaust gas with the engine at normal operating temperature.

Q: Was the exhaust gas checked with engine warmed sufficiently?

YES : Go to Step 2.

NO : Check it again after enough warm up.

STEP 2. Check the following items.

- (1) Check the following items.
- Check all vacuum hoses and connectors.
 - Check electrical wires and connectors for obvious problems.

Q: Are they normal?**YES** : Go to Step 3.**NO** : Repair or replace it. Then confirm that the malfunction symptom is eliminated.**STEP 3. Check the driveability.****Q: Is the driveability normal?****YES** : Go to Step 4.**NO** : Refer to Trouble Symptom Chart [P.13A-48](#).**STEP 4. Using scan tool MB991958, read the diagnostic trouble code (DTC).****⚠ CAUTION**

To prevent damage to scan tool MB991958, always turn the ignition switch to the "LOCK" (OFF) position before connecting or disconnecting scan tool MB991958.

- Connect scan tool MB991958 to the data link connector.
- Turn the ignition switch to the "ON" position.
- Read the DTC.
- Turn the ignition switch to the "LOCK" (OFF) position.

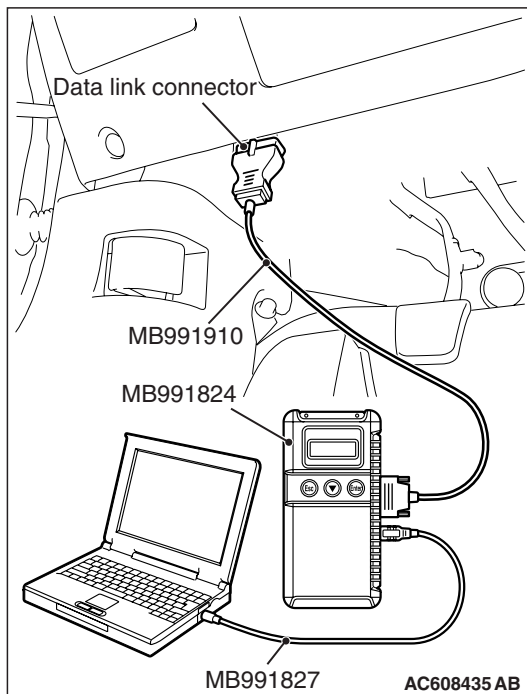
Q: Is any DTC set?**YES** : Refer to Diagnostic Trouble Code Chart [P.13A-44](#).**NO** : Go to Step 5.**STEP 5. Check the ignition timing.**

Refer to GROUP 11A, On-vehicle Service –Ignition Timing Check [P.11A-10](#).

Q: Is the ignition timing normal?**YES** : Go to Step 6.**NO** : Check that the crankshaft position sensor and timing chain case are in the correct position. Then confirm that the malfunction symptom is eliminated.

STEP 6. Using scan tool MB991958, check data list.

- (1) Turn the ignition switch to the "ON" position.
- (2) Check the following items in the data list. Refer to Data List Reference Table [P.13A-852](#).
 - a. Item 5: Intake Air Temperature Sensor.
 - b. Item 6: Engine Coolant Temperature Sensor.
 - c. Item AC: Heated Oxygen Sensor (front)
 - d. Item BB: Barometric Pressure Sensor
- (3) Turn the ignition switch to the "LOCK" (OFF) position.

Q: Are they operating properly?

YES : Go to Step 7.

NO : Repair or replace it. Then confirm that the malfunction symptom is eliminated.

STEP 7. Using scan tool MB991958, check data list item

AD: Heated oxygen sensor (rear).

- (1) Start the engine and run at idle.
- (2) Set scan tool MB991958 to the data reading mode for item AD, Heated Oxygen Sensor (rear).
 - a. Transaxle: 2nd
 - b. Drive with wide open throttle
 - c. Engine: 3,500 r/min
 - The output voltages should be between 0.6 and 1.0 volt.
- (3) Turn the ignition switch to the "LOCK" (OFF) position.

Q: Is the sensor operating properly?

YES : Go to Step 8.

NO : Refer to, P0137 –Heated Oxygen Sensor (rear) Circuit Low Voltage [P.13A-226](#), DTC P0138 –Heated Oxygen Sensor (rear) Circuit High Voltage [P.13A-234](#), DTC P0139 –Heated Oxygen Sensor (rear) Circuit Slow Response [P.13A-238](#), DTC P0140 –Heated Oxygen Sensor (rear) Circuit No Activity Detected [P.13A-242](#).

STEP 8. Check the fuel pressure.

Refer to Fuel Pressure Test [P.13A-897](#).

Q: Is the fuel pressure normal?

YES : Go to Step 9.

NO : Repair or replace it. Then confirm that the malfunction symptom is eliminated.

STEP 9. Check the spark plugs.

Refer to GROUP 16, Ignition System –On-vehicle Service – Spark Plug Check And Cleaning [P.16-37](#).

Q: Are there any abnormalities?

YES : Replace the spark plug. Then confirm that the malfunction symptom is eliminated.

NO : Go to Step 10.

STEP 10. Check the ignition coil.

Refer to GROUP 16, Ignition System –On-vehicle Service – Ignition Coil Check [P.16-36](#).

Q: Are there any abnormalities?

YES : Replace the ignition coil. Then confirm that the malfunction symptom is eliminated.

NO : Go to Step 11.

STEP 11. Check the compression pressure.

Refer to GROUP 11A, On-vehicle Service –Compression Pressure Check [P.11A-15](#).

Q: Is the compression pressure normal?

YES : Go to Step 12.

NO : Repair it. Then confirm that the malfunction symptom is eliminated.

STEP 12. Check the positive crankcase ventilation system.

Refer to GROUP 17, Emission Control –Positive Crankcase Ventilation System –Positive Crankcase Ventilation System Check [P.17-73](#).

Q: Is the positive crankcase ventilation system,?

YES : Go to Step 13.

NO : Repair it. Then confirm that the malfunction symptom is eliminated.

STEP 13. Check the evaporative emission control system.

Refer to GROUP 17, Emission Control –Evaporative Emission Control System –Purge Control System Check (Purge Flow Check) [P.17-76](#).

Q: Is the purge control system normal?

YES : Go to Step 14.

NO : Repair it. Then confirm that the malfunction symptom is eliminated.

STEP 14. Check the following items.

(1) Check the following items.

- a. Check the injectors for fuel leakage.
- b. Check if the injectors are clogged.

Q: Are there any abnormalities?

YES : Replace it. Then confirm that the malfunction symptom is eliminated.

Then confirm that the malfunction symptom is eliminated.

NO : Replace the catalytic converter. Then confirm that the malfunction symptom is eliminated.

Inspection procedure 19: Purge flow test of the evaporative emission canister failure

COMMENT

- The test fails when the purge line or purge port is clogged or if the evaporative emission purge solenoid fails.

TROUBLESHOOTING HINTS (The most likely causes for this case:)

- Purge line or purge port is clogged.
- Malfunction of the evaporative emission purge solenoid.
- Evaporative emission canister is clogged.

DIAGNOSIS

Required Special Tools:

- MB991958: Scan Tool (M.U.T.-III Sub Assembly)
 - MB991824: V.C.I.
 - MB991827: USB Cable
 - MB991910: Main Harness A

STEP 1. Using scan tool MB991958, read the diagnostic trouble code (DTC).

⚠ CAUTION

To prevent damage to scan tool MB991958, always turn the ignition switch to the "LOCK" (OFF) position before connecting or disconnecting scan tool MB991958.

- (1) Connect scan tool MB991958 to the data link connector.
- (2) Turn the ignition switch to the "ON" position.
- (3) Read the DTC.
- (4) Turn the ignition switch to the "LOCK" (OFF) position.

Q: Is any DTC set?

YES : Refer to Diagnostic Trouble Code Chart [P.13A-44](#).

NO : Refer to GROUP 17, Emission Control –Evaporative Emission Control System –Purge Control System Check (Purge Flow Check) [P.17-76](#).

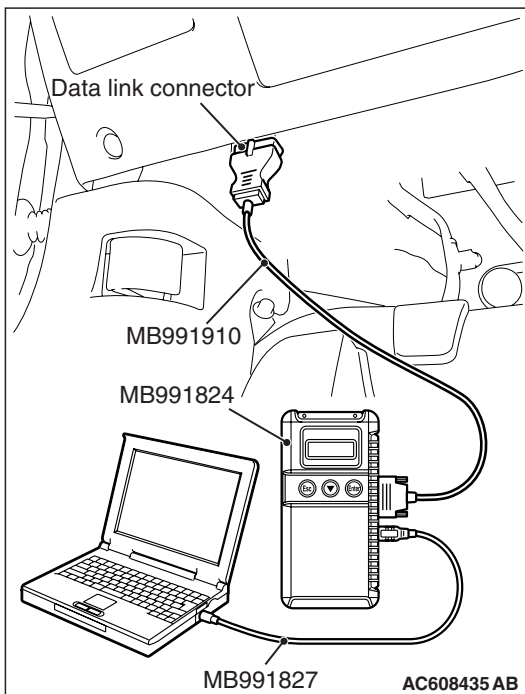

Inspection procedure 20: Pressure test of the evaporative system failure

COMMENT

- The test fails if there is a leak from the fuel tank or vapor line.

TROUBLESHOOTING HINTS (The most likely causes for this case:)

- Loose fuel tank filler tube cap.
- Broken seal in fuel tank, vapor line evaporative emission canister.

DIAGNOSIS

STEP 1. Check the evaporative emission purge solenoid.
Refer to GROUP 17, Emission Control –Evaporative Emission Control System –Evaporative Emission Purge Solenoid Check [P.17-77](#).

Q: Is the evaporative emission purge solenoid normal?

YES : Go to Step 2.

NO : Repair or replace it. Then confirm that the malfunction symptom is eliminated.

STEP 2. Check the evaporative emission ventilation solenoid.

Refer to GROUP 17, Emission Control –Evaporative Emission Canister And Fuel Tank Pressure Relief Valve –Inspection [P.17-80](#).

Q: Is the evaporative emission ventilation solenoid normal?

YES : Check the following items, and repair or replace the defective items.

a. Check for leaks from the vapor line or evaporative emission canister.

b. Check for leaks from the fuel tank.

Then confirm that the malfunction symptom is eliminated.

NO : Repair or replace it. Then confirm that the malfunction symptom is eliminated.

Inspection procedure 21: Generator output voltage is low (approximately 12.3 volts)

GENERATOR CIRCUIT

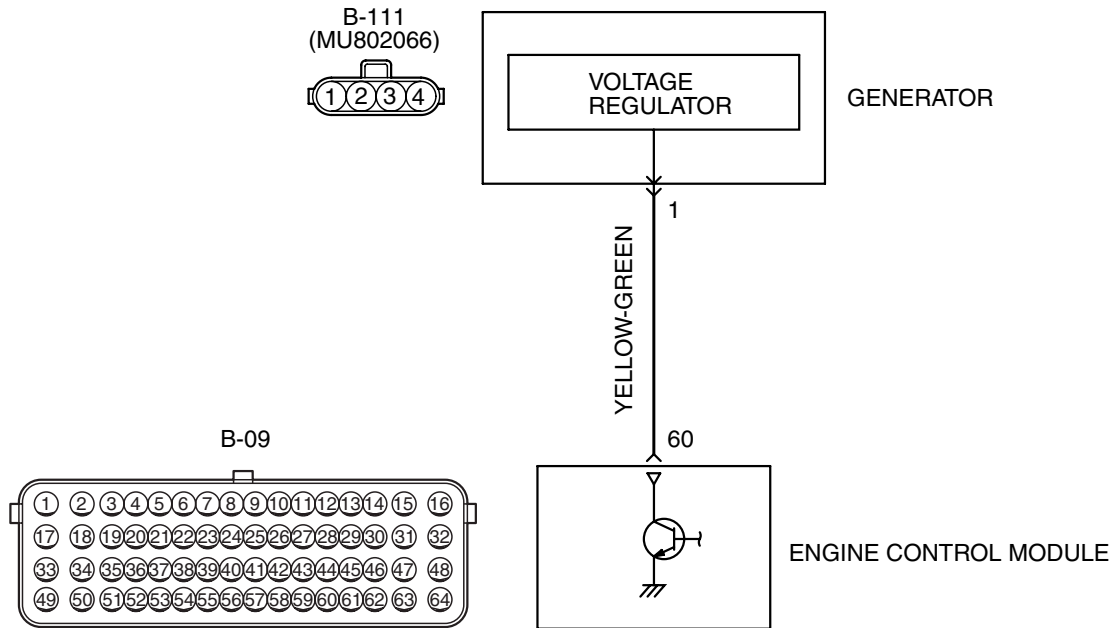

AK704301AC

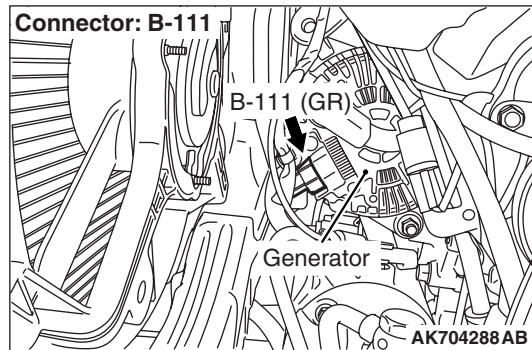
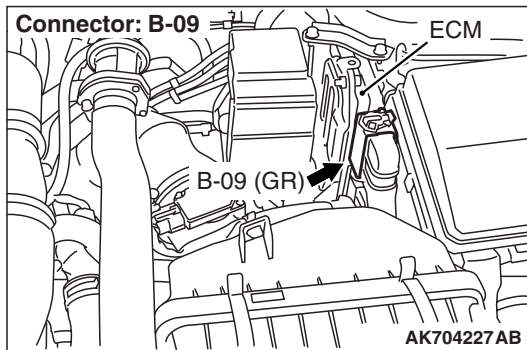

CIRCUIT OPERATION

- The ECM controls generator output current by duty-controlling continuity between the generator G terminal (terminal No. 1) and ground.

TROUBLESHOOTING HINTS (The most likely causes for this charging system:)

- Malfunction of the charging system.
- Short circuit in harness between generator G terminal and ECM.
- Malfunction of the ECM.

DIAGNOSIS

Required Special Tool:

- MB991923: Power Train ECU Check Harness

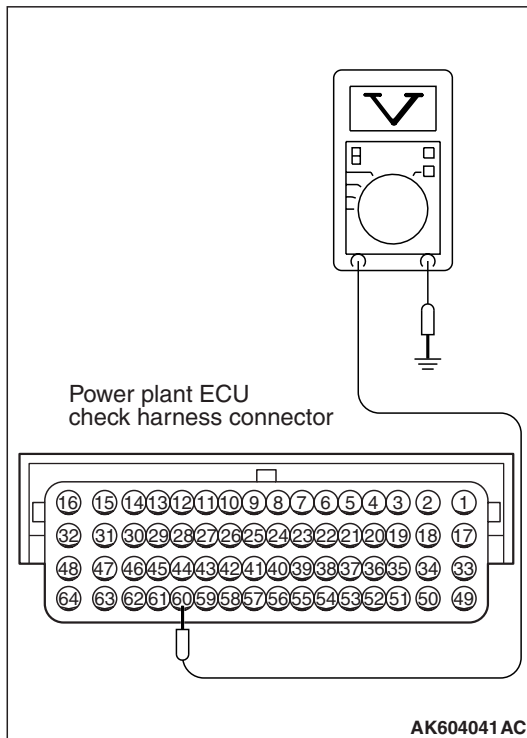
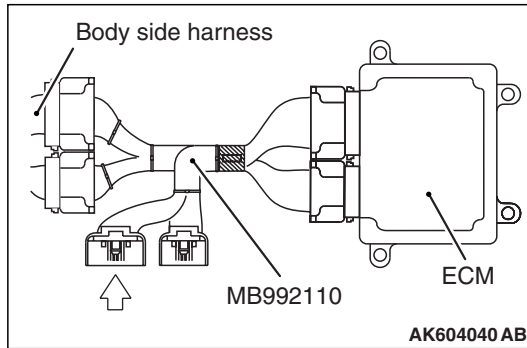

STEP 1. Measure the voltage at ECM connector B-09 by using power plant ECU check harness special tool MB992110.

(1) Disconnect all ECM connectors. Connect the power plant ECU check harness special tool MB992110 between the separated connectors.

(2) Start the engine and run at idle.

(3) Measure the voltage between terminal No. 60 and ground.
NOTE: Vehicle for Canada, the headlight, taillight, etc. remain lit even when the lighting switch is in "OFF" position but this is no problem for checks.

- a. Engine: warming up, idling
- b. Radiator fan: stopped
- c. Headlight: OFF to ON
- d. Stop light: OFF to ON
- e. Rear defogger switch: OFF to ON
 - Voltage increases

(4) Turn the ignition switch to the "LOCK" (OFF) position.

Q: Is the measured voltage within the specified range?

YES : Go to Step 2.

NO : Replace the generator. Then confirm that the malfunction symptom is eliminated.

STEP 2. Check harness connector B-09 at ECM connector and harness connector B-111 at generator connector for damage.

Q: Is the harness connector in good condition?

YES : Go to Step 3.

NO : Repair or replace it. Refer to GROUP 00E, Harness Connector Inspection [P.00E-2](#). Then confirm that the malfunction symptom is eliminated.

STEP 3. Check for short circuit to ground between generator connector B-111 (terminal No. 1) and ECM connector B-09 (terminal No. 60).

Q: Is the harness wire in good condition?

YES : Replace the ECM. When the ECM is replaced, register the ID code. Refer to GROUP 42B, Diagnosis –ID Code Registration Judgment Table <Vehicles with KOS> [P.42B-12](#) or GROUP 42C, Diagnosis –ID Codes Registration Judgment Table <Vehicles with WCM> [P.42C-9](#).

NO : Repair it. Then confirm that the malfunction symptom is eliminated.

Inspection procedure 22: Power supply system and ignition switch-IG system

POWER SUPPLY AND IGNITION SWITCH-IG CIRCUIT

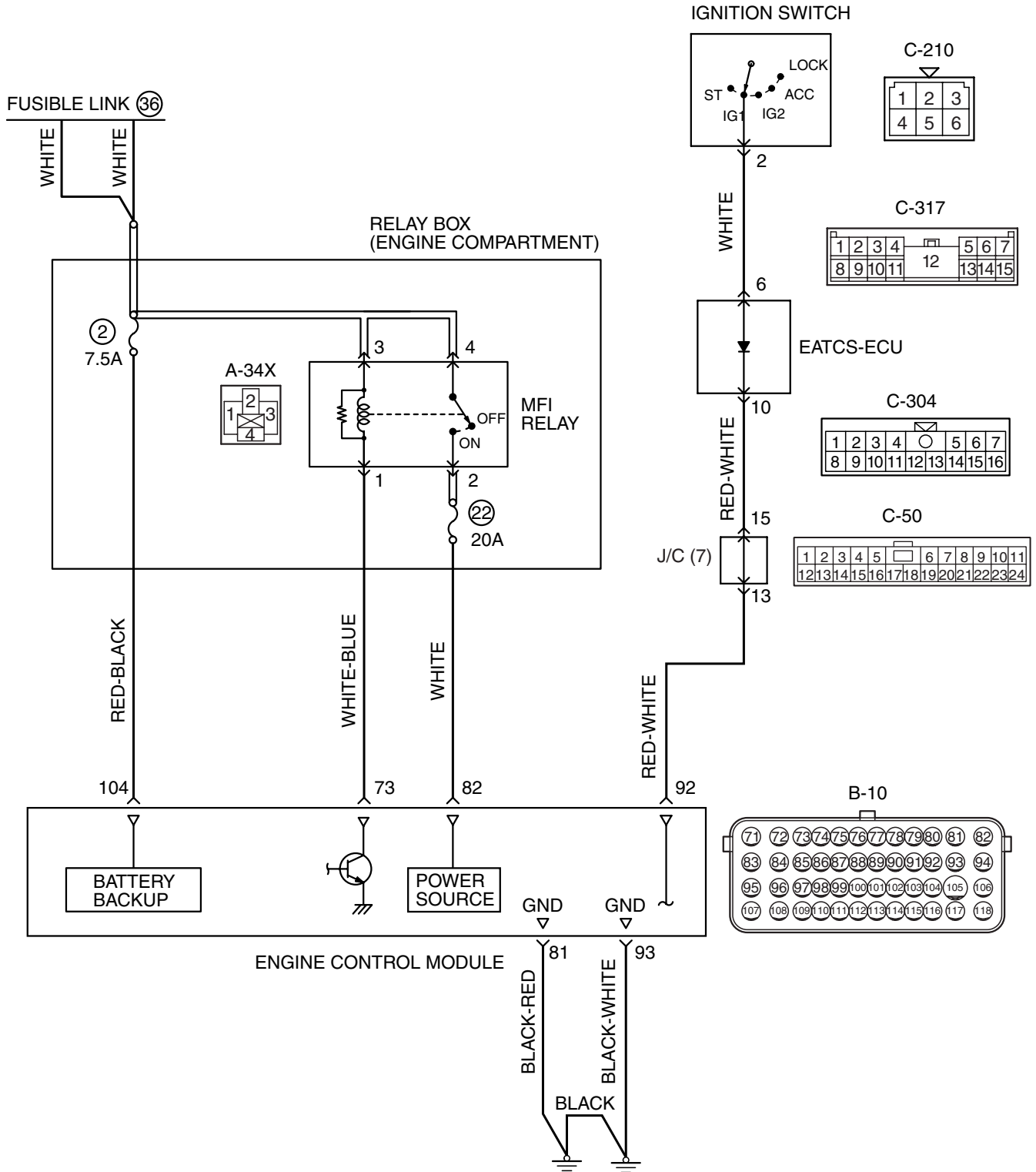

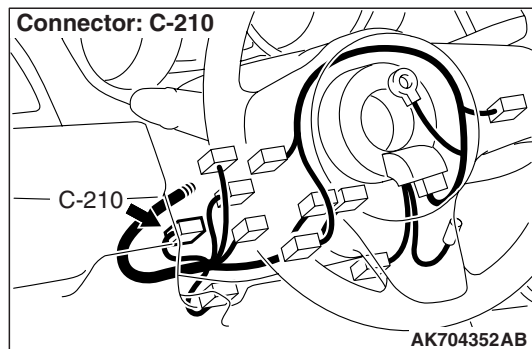
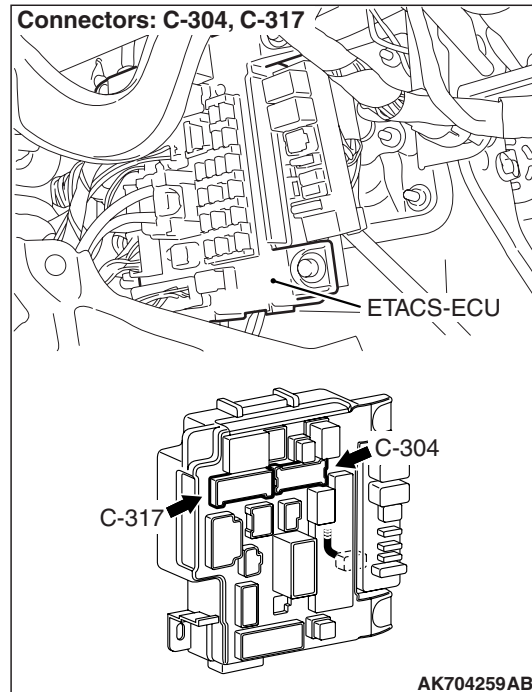
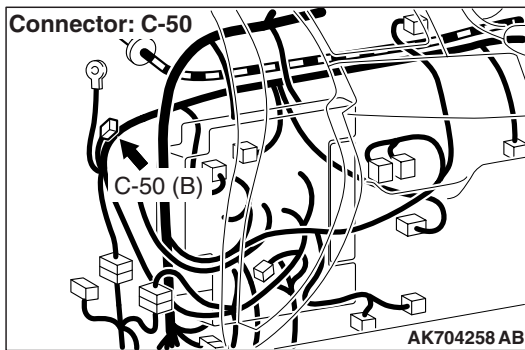
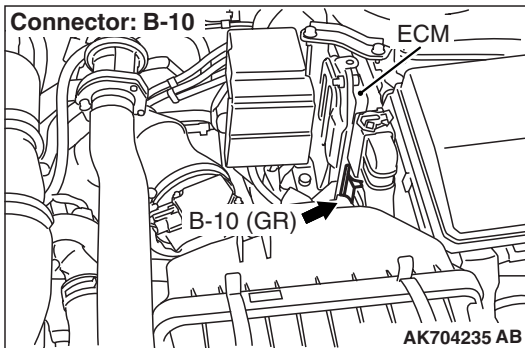
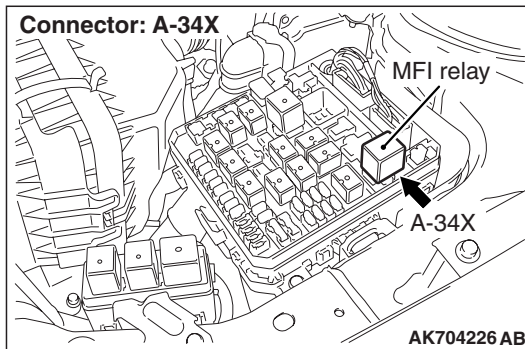

CIRCUIT OPERATION

- Battery positive voltage is applied to the MFI relay (terminals No. 3, No. 4).
- When the ignition switch is turned to the "ON" position, battery positive voltage is applied to the ECM (terminal No. 92). When battery positive voltage is applied, the ECM turns the power transistor in the ECM "ON" and grounds the MFI relay coil. With this, the MFI relay turns "ON" the battery positive voltage is supplied to the ECM (terminals No. 82) from the MFI relay (terminal No. 2).
- A battery positive voltage is constantly supplied to the ECM (terminal No. 104) as the backup power.
- The ECM (terminals No. 81, No. 93) is grounded to the vehicle body.

COMMENT

- When the ignition switch "ON" signal is input into the ECM via ETACS-ECU, the ECM turns "ON" the MFI relay. This causes battery positive voltage to be supplied to the ECM, sensor and actuator.

TROUBLESHOOTING HINTS (The most likely causes for this case)

- Malfunction of the ignition switch.
- Malfunction of the MFI relay.
- Open or shorted power supply and ignition Switch-IG circuit, harness damage, or connector damage.
- Malfunction of the ECM.

DIAGNOSIS

STEP 1. Check harness connector A-34X at MFI relay for damage.

Q: Is the connector in good condition?

YES : Go to Step 2.

NO : Repair or replace it. Refer to GROUP 00E, Harness Connector Inspection P.00E-2. Then confirm that the malfunction symptom is eliminated.

STEP 2. Check the MFI relay.

(1) Remove the MFI relay.

(2) Check for continuity between the MFI relay terminals No. 1 and No. 3.

- There should be continuity.

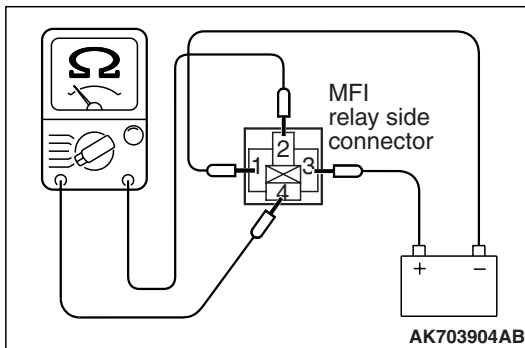
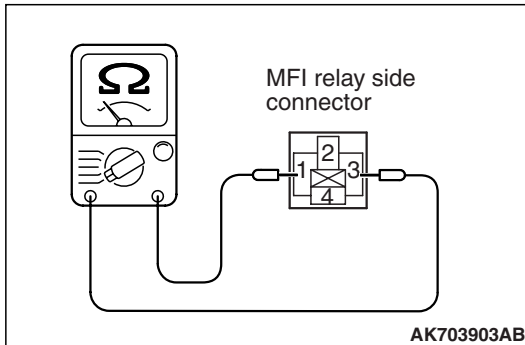

(3) Use jumper wires to connect MFI relay terminal No. 3 to the positive battery terminal and terminal No. 1 to the negative battery terminal.

(4) Check for continuity between the MFI relay terminals No. 4 and No. 2 while connecting and disconnecting the jumper wire at the negative battery terminal.

- Continuity (2 Ω or less) <Negative battery terminal connected>
- Should be open loop. <Negative battery terminal disconnected>

(5) Install the MFI relay.

Q: Is the measured resistance within the specified range?

YES : Go to Step 3.

NO : Replace the MFI relay. Then confirm that the malfunction symptom is eliminated.

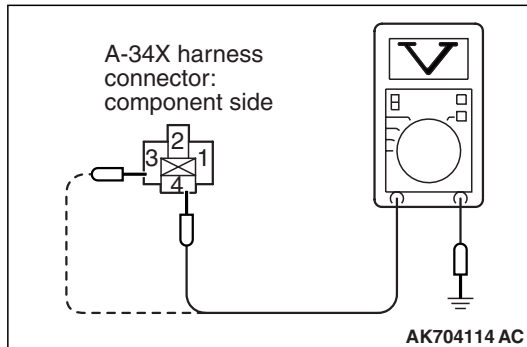

STEP 3. Measure the power supply voltage at MFI relay harness side connector A-34X.

- (1) Disconnect the connector A-34X and measure at the harness side.
- (2) Measure the voltage between terminals No. 3, No. 4 and ground.
 - Voltage should be battery positive voltage.

Q: Is battery positive voltage (approximately 12 volts) present?

YES : Go to Step 4.

NO : Repair harness wire between fusible link (36) and MFI relay connector A-34X (terminals No. 3, No. 4) because of open circuit or short circuit to ground. Then confirm that the malfunction symptom is eliminated.

STEP 4. Check harness connector B-10 at ECM for damage.

Q: Is the harness connector in good condition?

YES : Go to Step 5.

NO : Repair or replace it. Refer to GROUP 00E, Harness Connector Inspection P.00E-2. Then confirm that the malfunction symptom is eliminated.

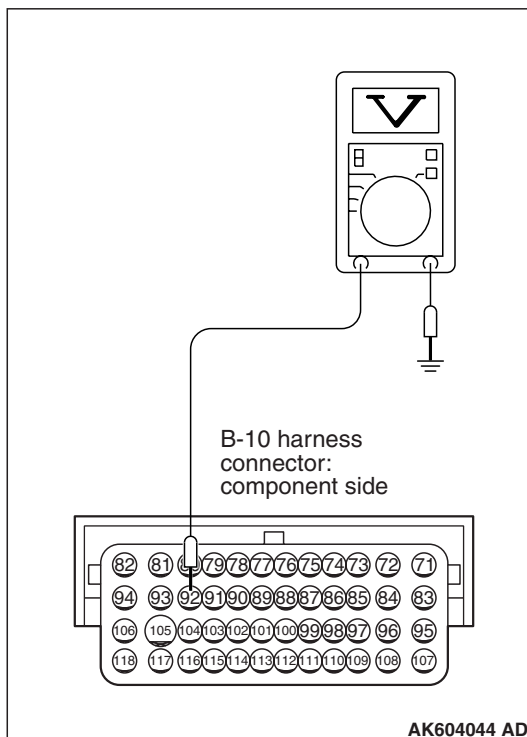

STEP 5. Measure the ignition switch-IG signal voltage at ECM harness side connector B-10.

- (1) Disconnect the connector B-10 and measure at the harness side.
- (2) Turn the ignition switch to the "ON" position.
- (3) Measure the voltage between terminal No. 92 and ground.
 - Voltage should be battery positive voltage.
- (4) Turn the ignition switch to the "LOCK" (OFF) position.

Q: Is battery positive voltage (approximately 12 volts) present?

YES : Go to Step 11.

NO : Go to Step 6.

STEP 6. Check harness connector C-304, C-317 at ETACS-ECU connector for damage.

Q: Is the connector in good condition?

YES : Go to Step 7.

NO : Repair or replace it. Refer to GROUP 00E, Harness Connector Inspection [P.00E-2](#). Then confirm that the malfunction symptom is eliminated.

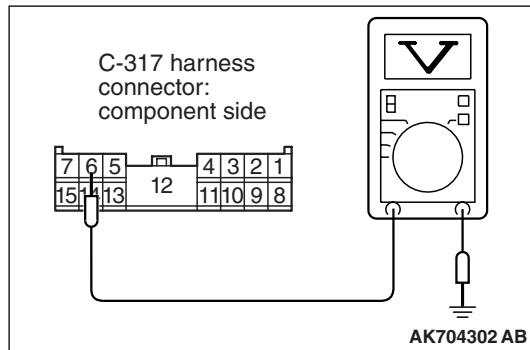

STEP 7. Measure the ignition switch-IG signal voltage at ETACS-ECU harness side connector C-317.

- (1) Disconnect the connector C-317 and measure at the harness side.
- (2) Turn the ignition switch to the "ON" position.
- (3) Measure the voltage between terminal No. 6 and ground.
 - Voltage should be battery positive voltage
- (4) Turn the ignition switch to the "LOCK" (OFF) position.

Q: Is battery positive voltage (approximately 12 volts) present?

YES : Go to Step 10.

NO : Go to Step 8.

STEP 8. Check harness connector C-210 ignition switch connector for damage.

Q: Is the connector in good condition?

YES : Go to Step 9.

NO : Repair or replace it. Refer to GROUP 00E, Harness Connector Inspection [P.00E-2](#). Then confirm that the malfunction symptom is eliminated.

STEP 9. Check the ignition switch

Refer to GROUP 54A, Ignition Switch –Inspection –Ignition Switch Continuity Check [P.54A-22](#).

Q: Are there any abnormalities?

YES : Replace the Ignition Switch. Then confirm that the malfunction symptom is eliminated.

NO : Repair harness wire between Ignition Switch connector C-210 (terminal No. 2) and ETACS-ECU connector C-317 (terminal No. 6) because of open circuit or short circuit to ground. Then confirm that the malfunction symptom is eliminated.

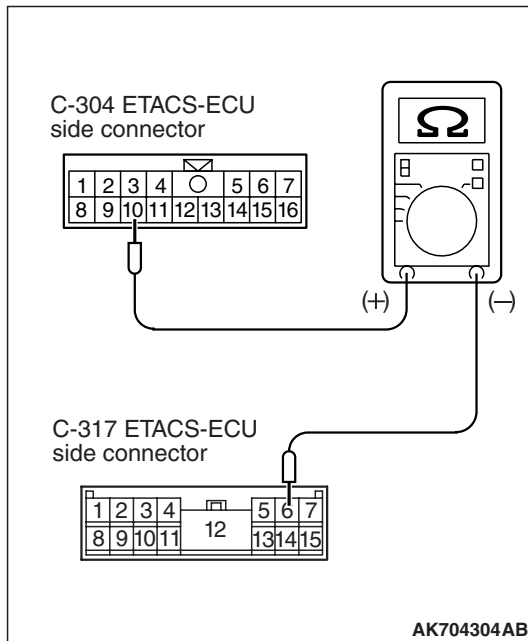

STEP 10. Check for continuity at ETACS-ECU side connector C-304 and C-317.

- (1) Disconnect the connector C-304, C-317 and measure at the ETACS-ECU side.
- (2) Measure the resistance between connector C-304 (terminal No. 10) and connector C-317 (terminal No. 6).

NOTE: Connect the (+) side of circuit tester to connector C-304 (terminal No. 10).

- Should be less than 2 ohms

Q: Is the harness wire in good condition?

YES : Check harness connector C-50 at intermediate connector for damage, and repair or replace as required. Refer to GROUP 00E, Harness Connector Inspection [P.00E-2](#). If intermediate connector is in good condition, repair harness wire between ETACS-ECU connector C-304 (terminal No. 10) and ECM connector B-10 (terminal No. 92) because of open circuit or short circuit to ground. Then confirm that the malfunction symptom is eliminated.

NO : Replace the ETACS-ECU. Then confirm that the malfunction symptom is eliminated.

STEP 11. Check harness connector C-304, C-317 at ETACS-ECU connector for damage.

Q: Is the connector in good condition?

YES : Go to Step 12.

NO : Repair or replace it. Refer to GROUP 00E, Harness Connector Inspection [P.00E-2](#). Then confirm that the malfunction symptom is eliminated.

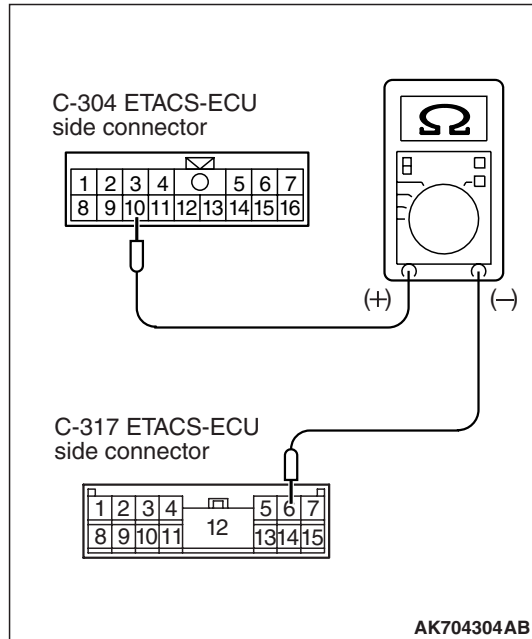

STEP 12. Check for continuity at ETACS-ECU side connector C-304 and C-317.

- (1) Disconnect the connector C-304, C-317 and measure at the ETACS-ECU side.
- (2) Measure the resistance between connector C-304 (terminal No. 10) and connector C-317 (terminal No. 6).

NOTE: Connect the (+) side of circuit tester to connector C-304 (terminal No. 10).

- Should be less than 2 ohms

Q: Is the harness wire in good condition?

YES : Go to Step 13.

NO : Repair or replace it. Refer to GROUP 00E, Harness Connector Inspection [P.00E-2](#).

STEP 13. Check harness connector C-210 ignition switch connector for damage.

Q: Is the connector in good condition?

YES : Go to Step 14.

NO : Repair or replace it. Refer to GROUP 00E, Harness Connector Inspection [P.00E-2](#). Then confirm that the malfunction symptom is eliminated.

STEP 14. Check for harness damage between ignition switch connector C-210 (terminal No. 2) and ETACS-ECU connector C-317 (terminal No. 6).

Q: Is the harness wire in good condition?

YES : Go to Step 15.

NO : Repair it. Then confirm that the malfunction symptom is eliminated.

STEP 15. Check for harness damage between ETACS-ECU connector C-304 (terminal No. 10) and ECM connector B-10 (terminal No. 92).

Q: Is the harness wire in good condition?

YES : Go to Step 16.

NO : Repair it. Then confirm that the malfunction symptom is eliminated.

STEP 16. Measure the backup power supply voltage at ECM harness side connector B-10.

- (1) Disconnect the connector B-10 and measure at the harness side.
- (2) Measure the voltage between terminal No. 104 and ground.
 - Voltage should be battery positive voltage.

Q: Is battery positive voltage (approximately 12 volts) present?

YES : Go to Step 17.

NO : Repair harness wire between fusible link (36) and ECM connector B-10 (terminal No. 104) because of short circuit to ground. Then confirm that the malfunction symptom is eliminated.

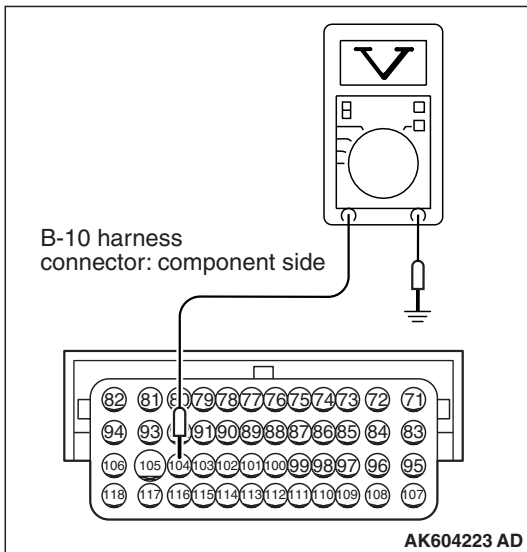

STEP 17. Check for continuity at ECM harness side connector B-10.

- (1) Disconnect the connector B-10 and measure at the harness side.
- (2) Check for the continuity between terminals (No. 81, No. 93) and ground.
 - Continuity (2Ω or less)

Q: Does continuity exist?

YES : Go to Step 18.

NO : Repair harness wire between ECM connector B-10 (terminal No. 81, No. 93) and ground because of open circuit or harness damage. Then confirm that the malfunction symptom is eliminated.

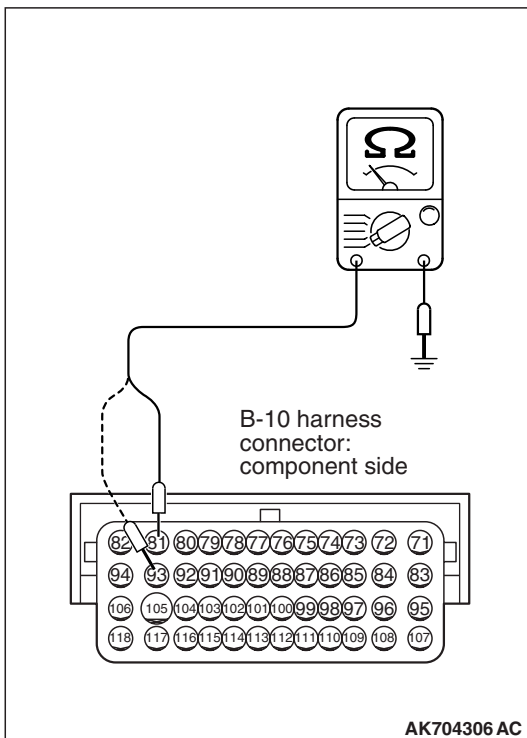

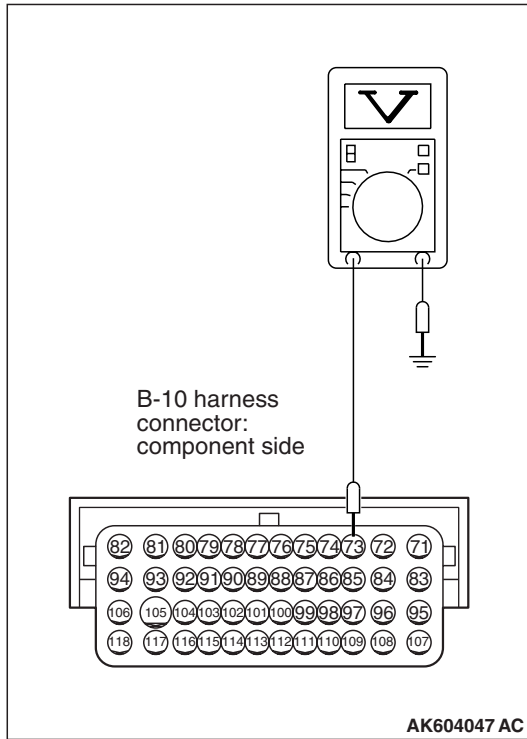

STEP 18. Measure the power supply voltage at ECM harness side connector B-10.

- (1) Disconnect the connector B-10 and measure at the harness side.
- (2) Measure the voltage between terminal No. 73 and ground.
 - Voltage should be battery positive voltage.

Q: Is battery positive voltage (approximately 12 volts) present?

YES : Go to Step 19.

NO : Repair harness wire between MFI relay connector A-34X (terminal No. 1) and ECM connector B-10 (terminal No. 73) because of open circuit. Then confirm that the malfunction symptom is eliminated.

STEP 19. Measure the power supply voltage at ECM harness side connector B-10.

- (1) Disconnect the connector B-10 and measure at the harness side.
- (2) Using a jumper wire, connect terminal No. 73 to ground.
- (3) Measure the voltage between terminal No. 82 and ground.
 - Voltage should be battery positive voltage.

Q: Is battery positive voltage (approximately 12 volts) present?

YES : Go to Step 22.

NO : Go to Step 20.

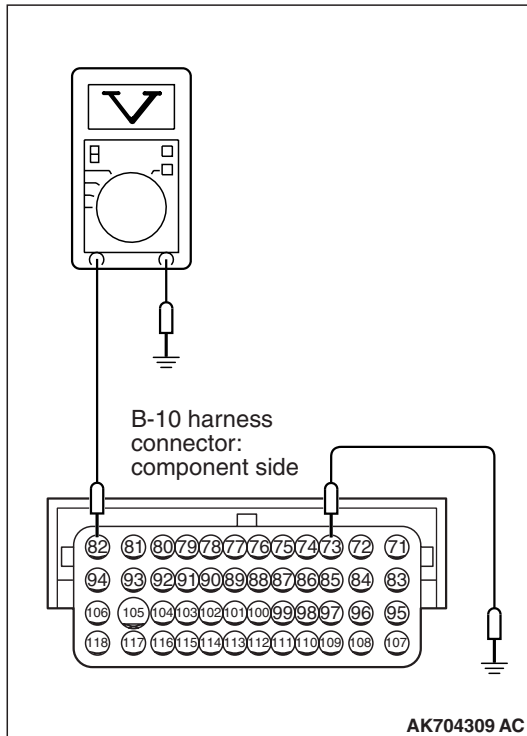

STEP 20. Check for open circuit and short circuit to ground between MFI relay connector A-34X (terminal No. 2) and ECM connector B-10 (terminal No. 73).

Q: Is the harness wire in good condition?

YES : Go to Step 21.

NO : Repair it. Then confirm that the malfunction symptom is eliminated.

STEP 21. Check for harness damage between fusible link (36) and MFI relay connector A-34X (terminal No. 3, No. 4).

Q: Is the harness wire in good condition?

YES : Repair harness wire between MFI relay connector A-34X (terminal No. 1) and ECM connector (terminal No. 73) because of harness damage. Then confirm that the malfunction symptom is eliminated.

NO : Repair it. Then confirm that the malfunction symptom is eliminated.

STEP 22. Check for harness damage between MFI relay connector A-34X (terminal No. 2) and ECM connector B-10 (terminal No. 82).

Q: Is the harness wire in good condition?

YES : Replace the ECM. When the ECM is replaced, register the ID code. Refer to GROUP 42B, Diagnosis –ID Code Registration Judgment Table <Vehicles with KOS> [P.42B-12](#) or GROUP 42C, Diagnosis –ID Codes Registration Judgment Table <Vehicles with WCM> [P.42C-9](#). Then confirm that the malfunction symptom is eliminated.

NO : Repair it. Then confirm that the malfunction symptom is eliminated.

Inspection procedure 23: Fuel pump system

FUEL PUMP CIRCUIT

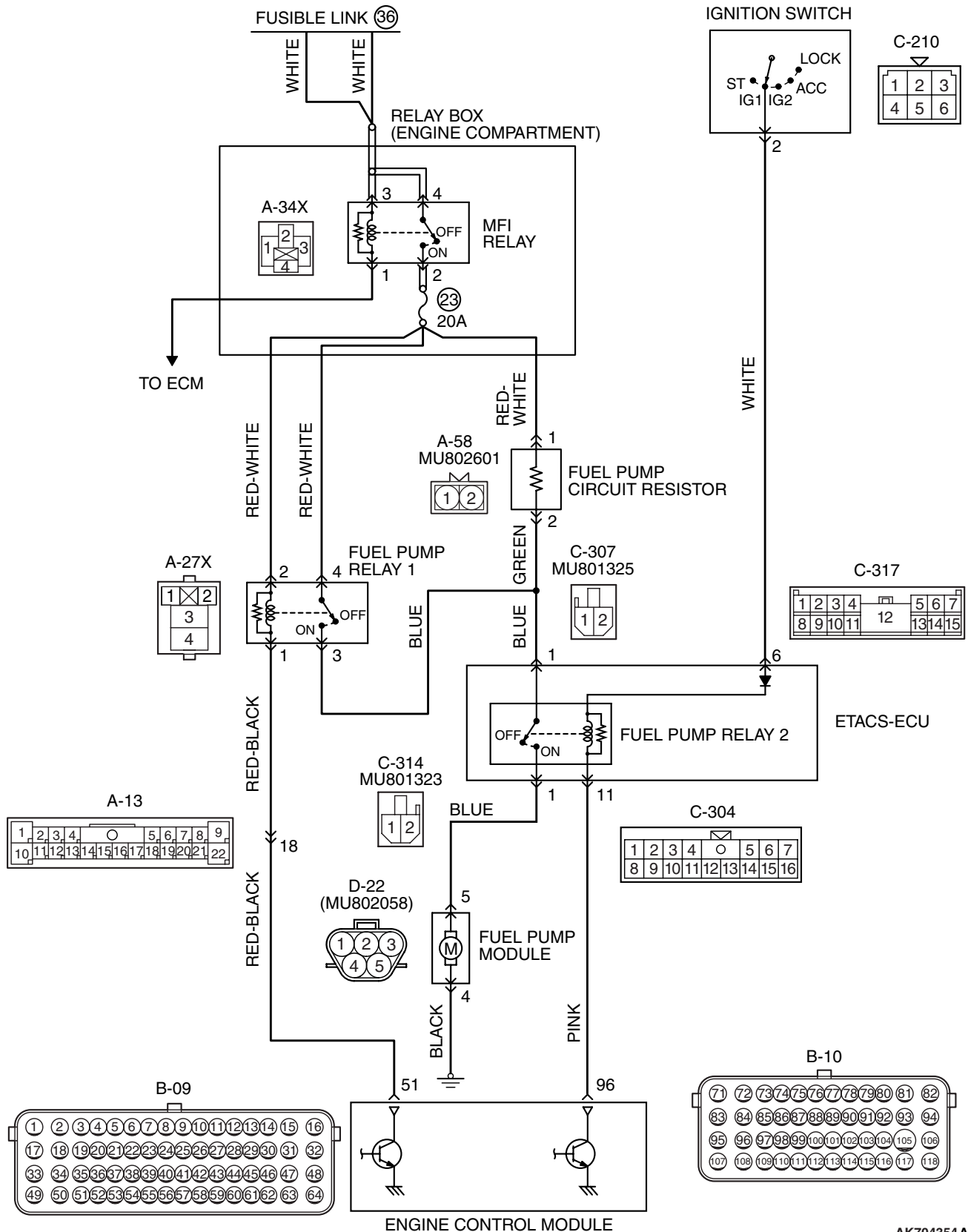

AK704354 AB

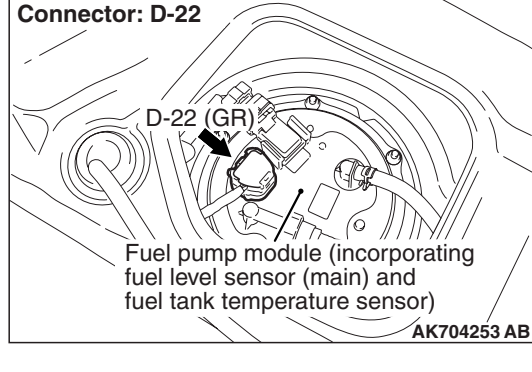
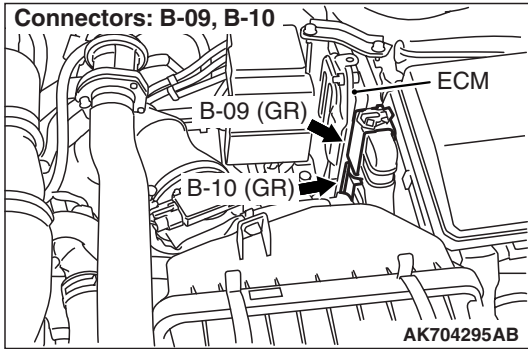
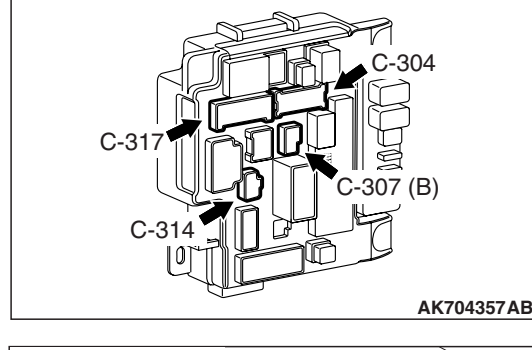
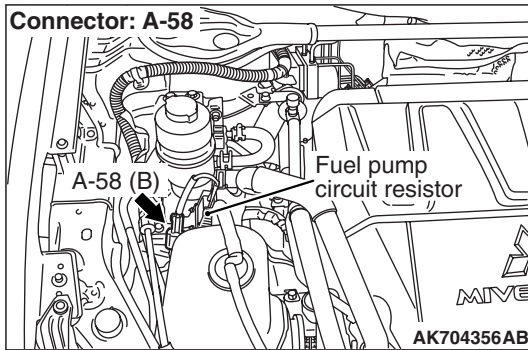
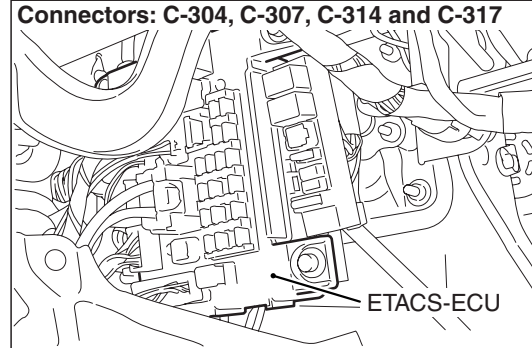
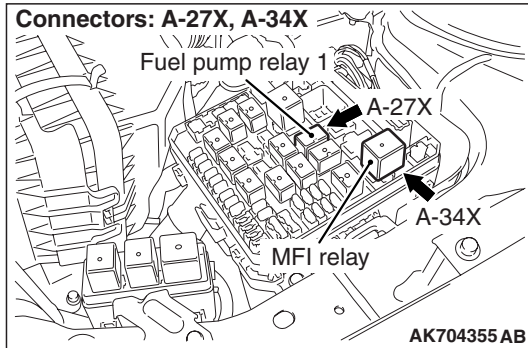
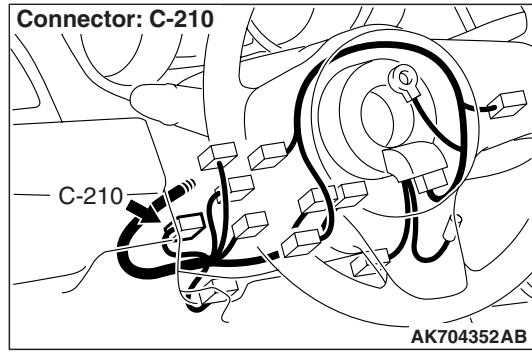
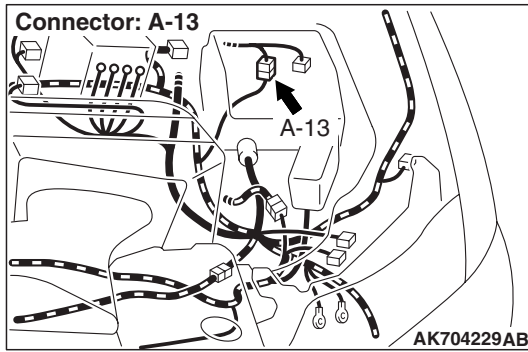

CIRCUIT OPERATION

- The power supply is supplied from the MFI relay (terminal No. 2) to the fuel pump relay 1 (terminal No. 4) and the fuel pump circuit resistor (terminal No. 1).
- The battery positive voltage is applied to the fuel pump relay 1 (terminal No. 2) from the MFI relay (terminal No. 2).

- The battery positive voltage is applied from the ignition switch to the fuel pump relay 2 (C-317 ETACS-ECU connector terminal No. 6).
- The ECM (terminal No. 96) turns ON the power transistor of the unit during the engine cranking and running. The current is going through the fuel pump relay 2 (C-304 ETACS-ECU connector terminal No. 11), and then the relay is turned ON.

- When the fuel pump relay 2 is turned ON, the fuel pump drive power is supplied from the fuel pump relay 2 (C-314 ETACS-ECU connector terminal No. 1) to the fuel pump (terminal No. 5).
- When the vehicle is driven at low engine loads, the ECM (terminal No. 51) turns OFF the power transistor of the unit. The current is not going through the fuel pump relay 1, and then the relay is turned OFF.
- When the vehicle is driven at high engine loads, the ECM (terminal No. 51) turns ON the power transistor of the unit. The current is going through the fuel pump relay 1 (terminal No. 1), and then the relay is turned ON. Thus the fuel pump drive power is supplied from the fuel pump relay 1 (terminal No. 3) to the fuel pump relay 2 (C-307 ETACS-ECU connector terminal No. 1).

COMMENT

- The ECM turns ON the fuel pump relay 2 during the engine cranking and running, and then supplies the drive power to the fuel pump.
- The ECM supplies the drive power to the fuel pump via the resistor during the engine running at low engine loads. The ECM supplies the drive power directly to the fuel pump during the engine running at high engine loads to increase the fuel discharge rate of fuel pump.

TROUBLESHOOTING HINTS (The most likely causes for this case:)

- Malfunction of the fuel pump relay 1.
- Malfunction of fuel pump relay 2 of ETACS-ECU.
- Malfunction of the fuel pump.
- Malfunction of the fuel pump circuit resistor.
- Improper connector contact, open or short-circu-
lated harness wire.
- Malfunction of the ECM.

DIAGNOSIS

Required Special Tools:

- MB991958: Scan Tool (M.U.T.-III Sub Assembly)
 - MB991824: V.C.I.
 - MB991827: USB Cable
 - MB991910: Main Harness A

STEP 1. Check harness connector C-304, C-307, C314 and C-317 at ETACS-ECU for damage.

Q: Is the connector in good condition?

YES : Go to Step 2.

NO : Repair or replace it. Refer to GROUP 00E, Harness Connector Inspection [P.00E-2](#). Then confirm that the malfunction symptom is eliminated.

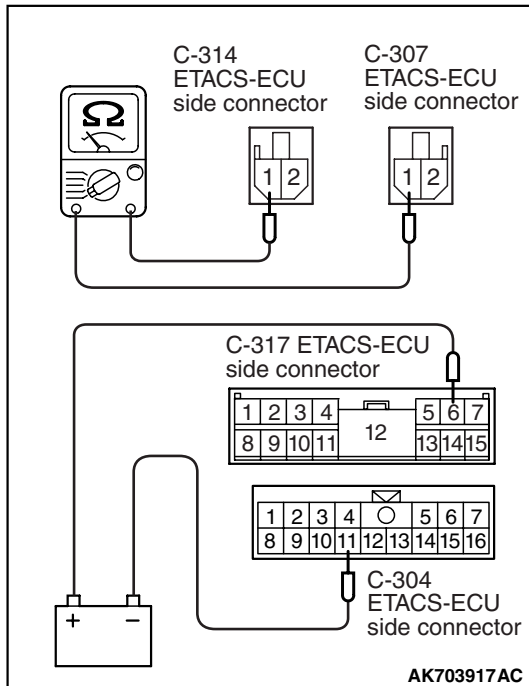
**STEP 2. Check the fuel pump relay 2.**

- (1) Remove the ETACS-ECU.
- (2) Use jumper wires to connect C-317 ETACS-ECU terminal No. 6 to the positive battery terminal and C-304 ETACS-ECU terminal No. 11 to the negative battery terminal.
- (3) Check for continuity between the C-307 ETACS-ECU terminal No. 1 and C-314 ETACS-ECU terminal No. 1 while connecting and disconnecting the jumper wire at the negative battery terminal.
 - Continuity ($2\ \Omega$ or less) <Negative battery terminal connected>
 - Should be open loop. <Negative battery terminal disconnected>
- (4) Install the ETACS-ECU.

Q: Is the measured resistance normal?**YES** : Go to Step 3.**NO** : Replace the ETACS-ECU. Then confirm that the malfunction symptom is eliminated.**STEP 3. Check harness connector A-27X at fuel pump relay 1 for damage.****Q: Is the connector in good condition?****YES** : Go to Step 4.**NO** : Repair or replace it. Refer to GROUP 00E, Harness Connector Inspection [P.00E-2](#). Then confirm that the malfunction symptom is eliminated.

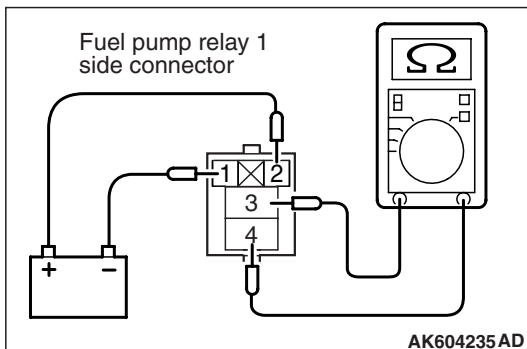
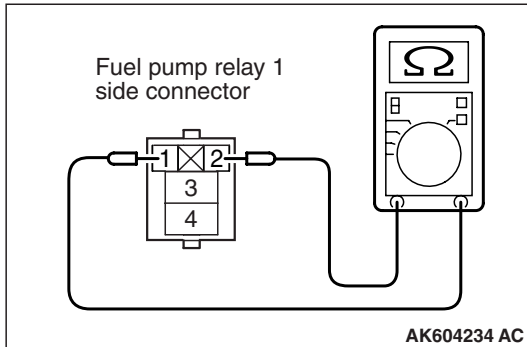

STEP 4. Check the fuel pump relay 1.

- (1) Remove the fuel pump relay 1.
- (2) Check for continuity between the throttle actuator control motor relay terminal No. 1 and No. 2.
 - There should be continuity.

- (3) Use jumper wires to connect fuel pump relay 1 terminal No. 2 to the positive battery terminal and terminal No. 1 to the negative battery terminal.

- (4) Check the continuity between the fuel pump relay 1 terminal No. 3 and No. 4 while connecting and disconnecting the jumper wire at the negative battery terminal.
 - Continuity (2 Ω or less) <Negative battery terminal connected.>
 - Should be open loop. <Negative battery terminal disconnected.>

- Continuity (2 Ω or less) <Negative battery terminal connected.>
- Should be open loop. <Negative battery terminal disconnected.>

- (5) Install the throttle actuator control motor relay.

Q: Is the measured resistance normal?

YES : Go to Step 5.

NO : Replace the fuel pump relay 1. Then confirm that the malfunction symptom eliminated.

STEP 5. Check harness connector A-58 fuel pump circuit resistor.

Q: Is the connector in good condition?

YES : Go to Step 6.

NO : Repair or replace it. Refer to GROUP 00E, Harness Connector Inspection [P.00E-2](#). Then confirm that the malfunction symptom is eliminated.

STEP 6. Check the fuel pump circuit resistor.

- (1) Disconnect the fuel pump circuit resistor connector.
- (2) Measure the resistance between terminals.

Standard value: 0.45 – 0.65 Ω [at 20° C (68° F)]

Q: Is the measured resistance normal?

YES : Go to Step 7.

NO : Replace the fuel pump circuit resistor. Then confirm that the malfunction symptom eliminated.

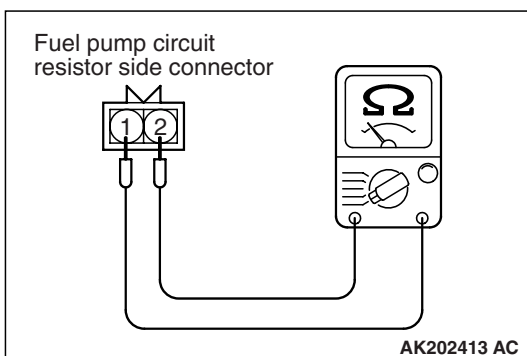

STEP 7. Check harness connector B-10 at ECM for damage.

Q: Is the connector in good condition?

YES : Go to Step 8.

NO : Repair or replace it. Refer to GROUP 00E, Harness Connector Inspection [P.00E-2](#). Then confirm that the malfunction symptom is eliminated.

STEP 8. Measure the power supply voltage at ECM connector B-10.

- (1) Disconnect the connector B-10 and measure at the harness side.
- (2) Turn the ignition switch to the "ON" position.
- (3) Measure the voltage between terminal No. 96 and ground.
 - Voltage should be battery positive voltage.
- (4) Turn the ignition switch to the "LOCK" (OFF) position.

Q: Is battery positive voltage (approximately 12 volts) present?

YES : Go to Step 9.

NO : Repair harness wire between ETACS-ECU connector C-304 (terminal No. 11) and ECM connector B-10 (terminal No. 96) because of open circuit. Then confirm that the malfunction symptom is eliminated.

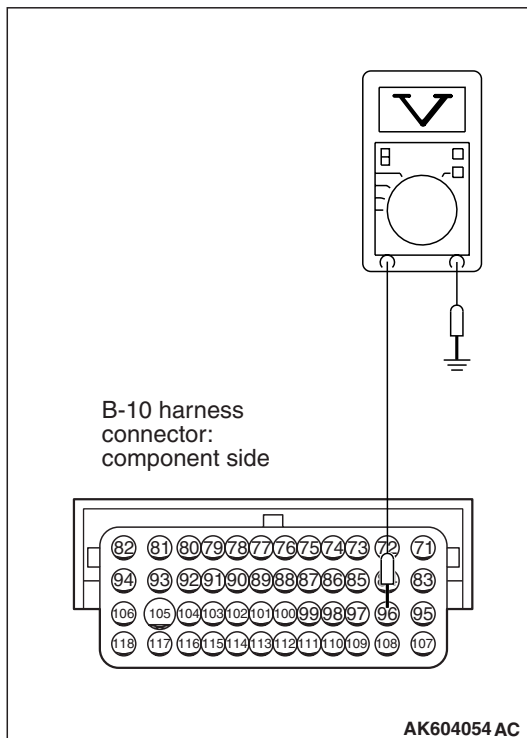

STEP 9. Check harness connector B-09 at ECM for damage.

Q: Is the connector in good condition?

YES : Go to Step 10.

NO : Repair or replace it. Refer to GROUP 00E, Harness Connector Inspection [P.00E-2](#). Then confirm that the malfunction symptom is eliminated.

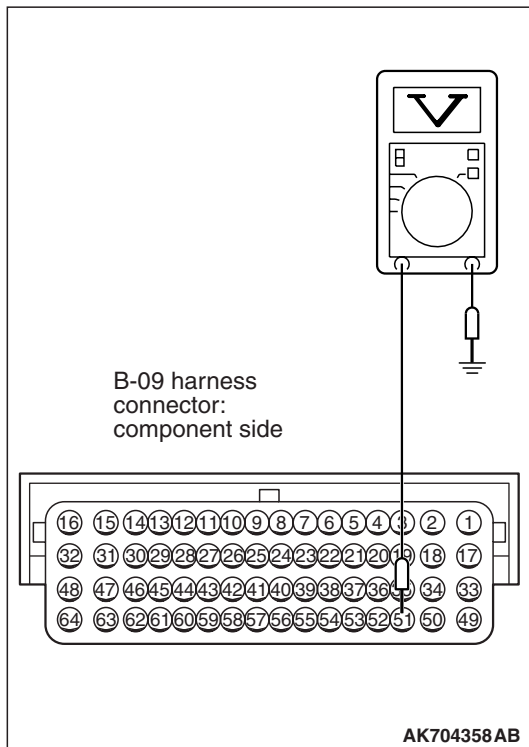

STEP 10. Measure the power supply voltage at ECM connector B-09.

- (1) Disconnect the connector B-09 and measure at the harness side.
- (2) Turn the ignition switch to the "ON" position.
- (3) Measure the voltage between terminal No. 51 and ground.
 - Voltage should be battery positive voltage.
- (4) Turn the ignition switch to the "LOCK" (OFF) position.

Q: Is battery positive voltage (approximately 12 volts) present?

YES : Go to Step 13.

NO : Go to Step 11.

STEP 11. Check for open circuit and short circuit to ground between fuel pump relay 1 connector A-27X (terminal No. 1) and ECM connector B-09 (terminal No. 51).

NOTE: Check harness after checking intermediate connector A-13. If intermediate connector is damaged, repair or replace it. Refer to GROUP 00E, Harness Connector Inspection P.00E-2. Then check that the malfunction is eliminated.

Q: Is the harness wire in good condition?

YES : Go to Step 12.

NO : Repair or replace it. Then confirm that the malfunction symptom is eliminated.

STEP 12. Check harness connector A-34X at MFI relay for damage.

Q: Is the connector in good condition?

YES : Repair harness wire between fuel pump relay 1 connector (terminal No. 2) and MFI relay connector (terminal No. 2) because of open circuit. Then confirm that the malfunction symptom is eliminated.

NO : Repair or replace it. Refer to GROUP 00E, Harness Connector Inspection P.00E-2. Then confirm that the malfunction symptom is eliminated.

STEP 13. Check harness connector D-22 at fuel pump for damage.

Q: Is the connector in good condition?

YES : Go to Step 14.

NO : Repair or replace it. Refer to GROUP 00E, Harness Connector Inspection [P.00E-2](#). Then confirm that the malfunction symptom is eliminated.

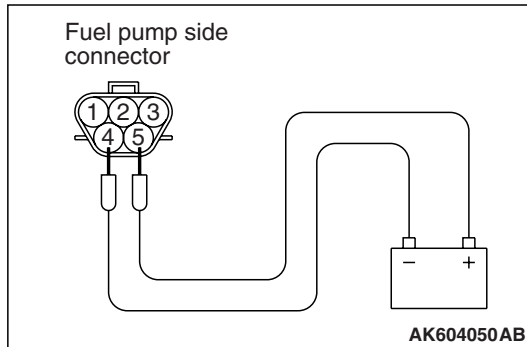

STEP 14. Check the fuel pump operation.

- (1) Disconnect fuel pump connector D-22.
- (2) Use jumper wire to connect fuel pump terminal No. 5 to the positive battery terminal and terminal No. 4 the negative battery terminal.
 - An operating sound of the fuel pump should be heard.

Q: Is the fuel pump operating properly?

YES : Go to Step 15.

NO : Replace the fuel pump. Then confirm that the malfunction symptom is eliminated.

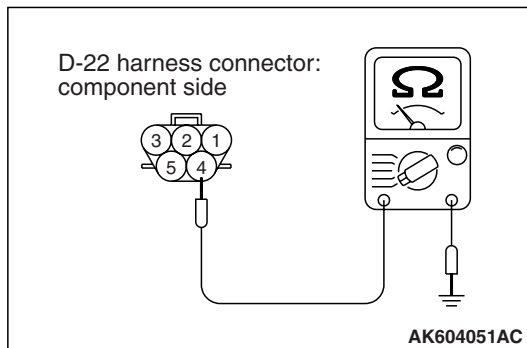

STEP 15. Check for continuity at fuel pump harness side connector D-22.

- (1) Disconnect the connector D-22 and measure at the harness side.
- (2) Check for the continuity between terminal No. 4 and ground.
 - Should be less than 2 ohms.

Q: Does continuity exist?

YES : Go to Step 16.

NO : Repair harness wire between fuel pump connector D-22 (terminal No. 4) and ground because of open circuit and harness damage. Then confirm that the malfunction symptom is eliminated.

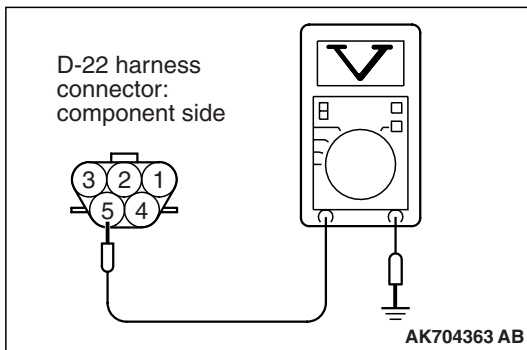
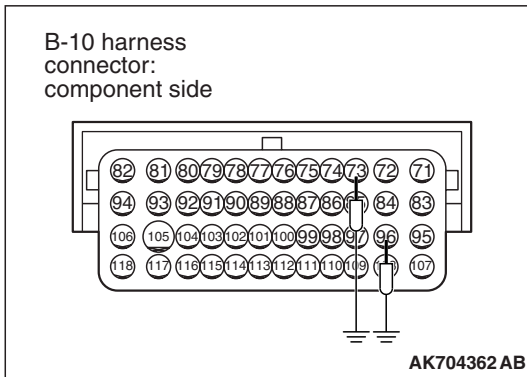

STEP 16. Measurement power supply voltage at fuel pump relay harness side connector D-22.

- (1) Disconnect the connector D-22 and measure at the harness side.
- (2) Disconnect the ECM connector B-10, and connect terminal No. 73 and No. 96 to ground using a jumper wire.
- (3) Turn the ignition switch to the "ON" position.
- (4) Measure the voltage between terminal No. 5 and ground.
 - Voltage should be battery positive voltage.
- (5) Turn the ignition switch to the "LOCK" (OFF) position.

Q: Is battery positive voltage (approximately 12 volts) present?

YES : Go to Step 22.

NO : Go to Step 17.

STEP 17. Check for open circuit and short circuit to ground between fuel pump connector D-22 (terminal No. 5) and ETACS-ECU connector C-314 (terminal No. 1).

Q: Is the harness wire in good condition?

YES : Go to Step 18.

NO : Repair or replace it. Then confirm that the malfunction symptom is eliminated.

STEP 18. Check for open circuit and short circuit to ground between fuel pump circuit resistor connector A-58 (terminal No. 2) and ETACS-ECU connector C-307 (terminal No. 1).

Q: Is the harness wire in good condition?

YES : Go to Step 19.

NO : Repair or replace it. Then confirm that the malfunction symptom is eliminated.

STEP 19. Check harness connector A-34X at MFI relay for damage.

Q: Is the connector in good condition?

YES : Go to Step 20.

NO : Repair or replace it. Refer to GROUP 00E, Harness Connector Inspection [P.00E-2](#). Then confirm that the malfunction symptom is eliminated.

STEP 20. Check for open circuit and short circuit to ground between MFI relay connector A-34X (terminal No. 2) and fuel pump circuit resistor connector A-58 (terminal No. 1).

Q: Is the harness wire in good condition?

YES : Go to Step 21.

NO : Repair or replace it. Then confirm that the malfunction symptom is eliminated.

STEP 21. Check for short circuit to ground between fuel pump relay 1 connector A-27X (terminal No. 3) and ETACS-ECU connector C-307 (terminal No. 1).

Q: Is the harness wire in good condition?

YES : Go to Step 22.

NO : Repair or replace it. Then confirm that the malfunction symptom is eliminated.

STEP 22. Measurement power supply voltage at ETACS-ECU harness side connector C-307.

- (1) Disconnect the connector C-307 and measure at the harness side.
- (2) Disconnect the ECM connector B-09, and connect terminal No. 51 to ground using a jumper wire.
- (3) Disconnect the ECM connector B-10, and connect terminal No. 73 to ground using a jumper wire.
- (4) Turn the ignition switch to the "ON" position.
- (5) Measure the voltage between terminal No. 1 and ground.
 - Voltage should be battery positive voltage.
- (6) Turn the ignition switch to the "LOCK" (OFF) position.

Q: Is battery positive voltage (approximately 12 volts) present?

YES : Go to Step 27.

NO : Go to Step 23.

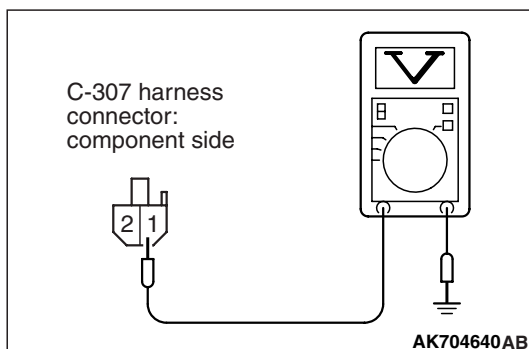
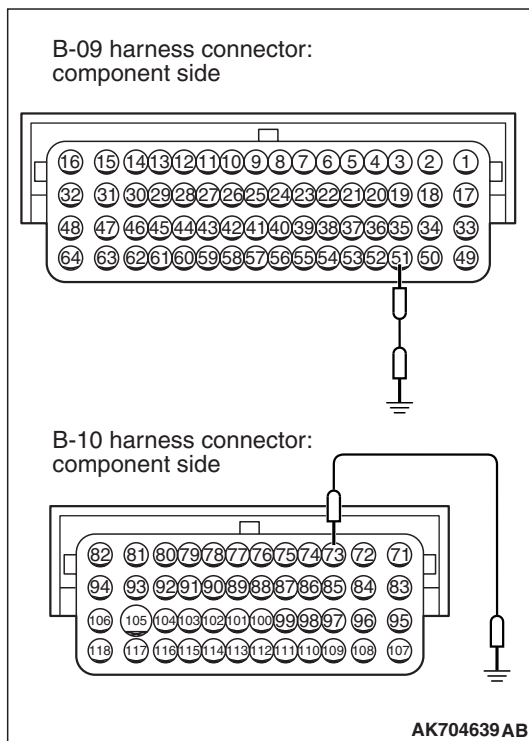

STEP 23. Check for open circuit between fuel pump relay 1 connector A-28X (terminal No. 3) and ETACS-ECU connector C-307 (terminal No. 1).

Q: Is the harness wire in good condition?

YES : Go to Step 24.

NO : Repair or replace it. Then confirm that the malfunction symptom is eliminated.

STEP 24. Check harness connector A-34X at MFI relay for damage.

Q: Is the connector in good condition?

YES : Go to Step 25.

NO : Repair or replace it. Refer to GROUP 00E, Harness Connector Inspection [P.00E-2](#). Then confirm that the malfunction symptom is eliminated.

STEP 25. Check for open circuit and short circuit to ground between fuel pump relay 1 connector A-27X (terminal No. 4) and MFI relay connector A-34X (terminal No. 2).

Q: Is the harness wire in good condition?

YES : Go to Step 26.

NO : Repair or replace it. Then confirm that the malfunction symptom is eliminated.

STEP 26. Check for harness damage between fuel pump relay 1 connector A-27X (terminal No. 1) and ECM connector B-09 (terminal No. 51).

NOTE: Check harness after checking intermediate connector A-13. If intermediate connector is damaged, repair or replace it. Refer to GROUP 00E, Harness Connector Inspection [P.00E-2](#). Then check that the malfunction is eliminated.

Q: Is the harness wire in good condition?

YES : Repair harness wire between fuel pump relay 1 connector A-27X (terminal No. 2) and MFI relay connector A-34X (terminal No. 2) because of harness damage. Then confirm that the malfunction symptom is eliminated.

NO : Repair or replace it. Then confirm that the malfunction symptom is eliminated.

STEP 27. Check for harness damage between fuel pump connector D-22 (terminal No. 5) and ETACS-ECU connector C-314 (terminal No. 1).

Q: Is the harness wire in good condition?

YES : Go to Step 28.

NO : Repair or replace it. Then confirm that the malfunction symptom is eliminated.

STEP 28. Check for harness damage between fuel pump circuit resistor connector A-58 (terminal No. 2) and ETACS-ECU connector C-307 (terminal No. 1).

Q: Is the harness wire in good condition?

YES : Go to Step 29.

NO : Repair or replace it. Then confirm that the malfunction symptom is eliminated.

STEP 29. Check harness connector A-34X at MFI relay for damage.

Q: Is the connector in good condition?

YES : Go to Step 30.

NO : Repair or replace it. Refer to GROUP 00E, Harness Connector Inspection [P.00E-2](#). Then confirm that the malfunction symptom is eliminated.

STEP 30. Check for harness damage between MFI relay connector A-34X (terminal No. 2) and fuel pump resistor connector A-58 (terminal No. 1).

Q: Is the harness wire in good condition?

YES : Go to Step 31.

NO : Repair or replace it. Then confirm that the malfunction symptom is eliminated.

STEP 31. Check for harness damage between fuel pump relay 1 connector A-27X (terminal No. 3) and ETACS-ECU connector C-307 (terminal No. 1).

Q: Is the harness wire in good condition?

YES : Go to Step 32.

NO : Repair or replace it. Then confirm that the malfunction symptom is eliminated.

STEP 32. Check for harness damage between fuel pump relay 1 connector A-27X (terminal No. 4) and MFI relay connector A-34X (terminal No. 2).

Q: Is the harness wire in good condition?

YES : Go to Step 33.

NO : Repair or replace it. Then confirm that the malfunction symptom is eliminated.

STEP 33. Using scan tool MB991958, check actuator test item 9: Fuel Pump.

⚠ CAUTION

To prevent damage to scan tool MB991958, always turn the ignition switch to the "LOCK" (OFF) position before connecting or disconnecting scan tool MB991958.

- (1) Connect scan tool MB991958 to the data link connector.
- (2) Turn the ignition switch to the "ON" position.
- (3) Set scan tool MB991958 to the actuator test mode for item 9, Fuel Pump.
- (4) Turn the ignition switch to the "LOCK" (OFF) position.

Q: Is the fuel pump operating properly?

YES : It can be assumed that this malfunction is intermittent, Refer to GROUP 00, How to Use Troubleshooting – Inspection Service Points –How to Cope with Intermittent Malfunctions [P.00-15](#).

NO : Replace the ECM. When the ECM is replaced, register the ID code. Refer to GROUP 42B, ID Code Registration Necessity Judgment Table <Vehicles with KOS> [P.42B-12](#) or GROUP 42C, ID Codes Registration Judgment Table <Vehicles with WCM> [P.42C-9](#).

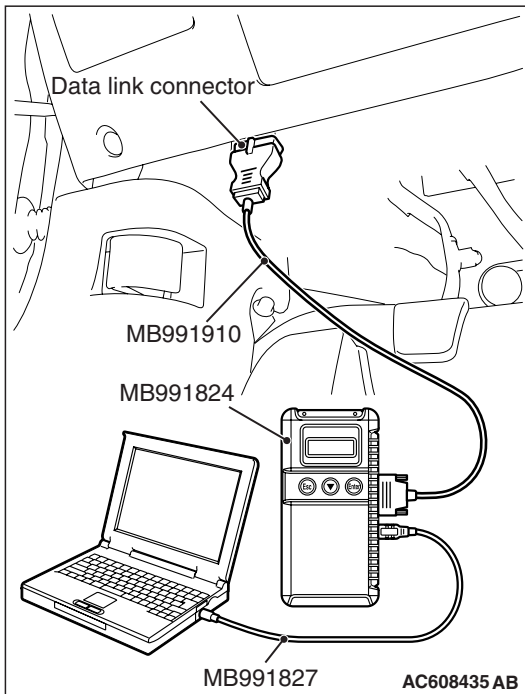

Inspection procedure 24: Ignition switch-ST system and starter relay system <M/T>

STARTING SYSTEM CIRCUIT <M/T>

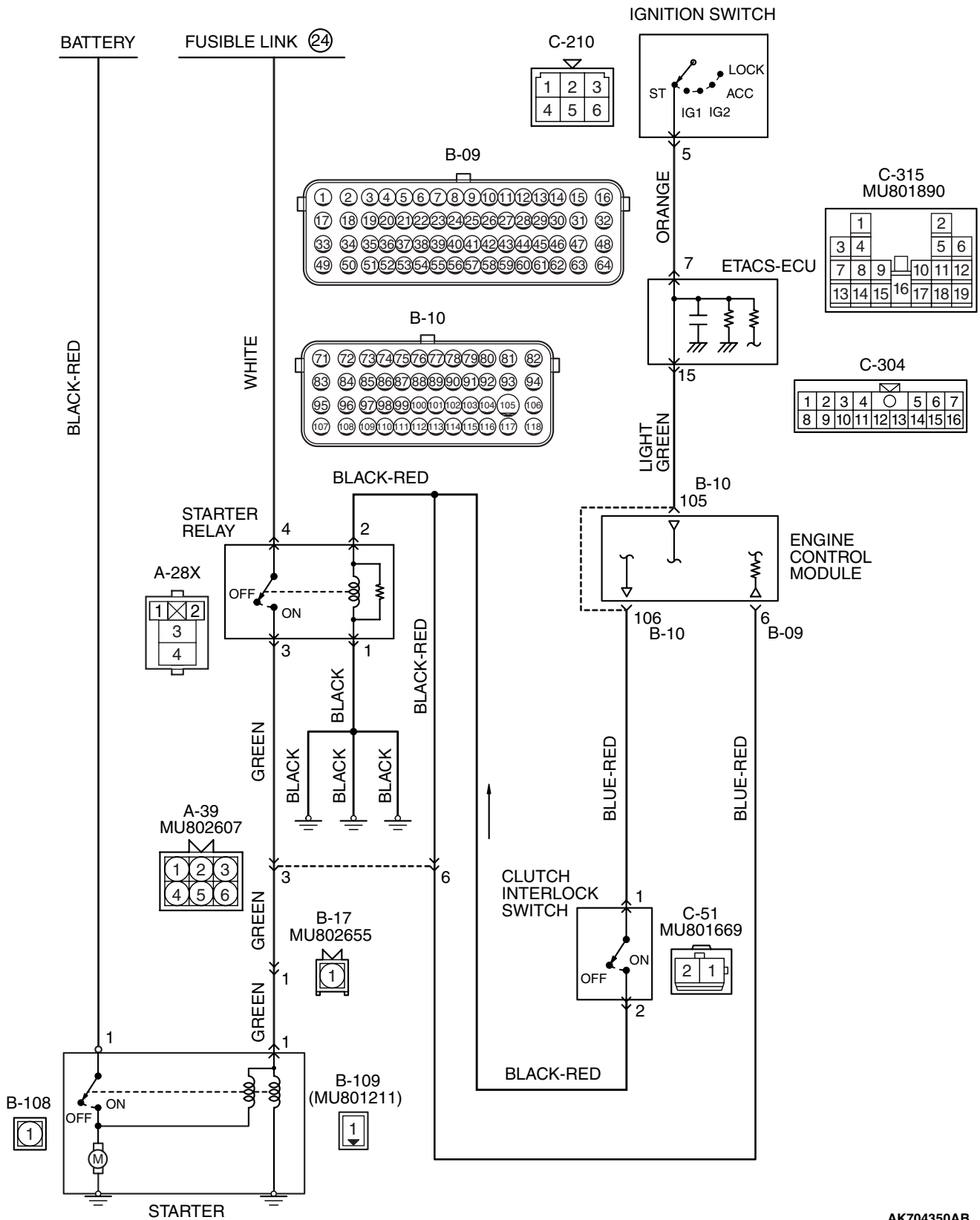

AK704350AB

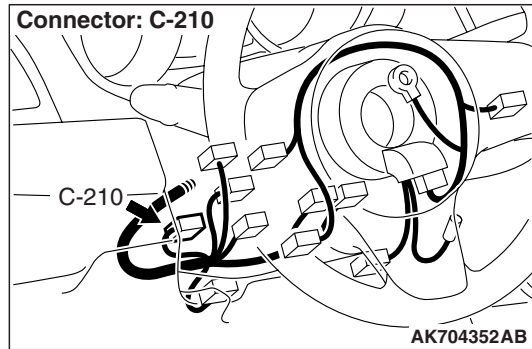
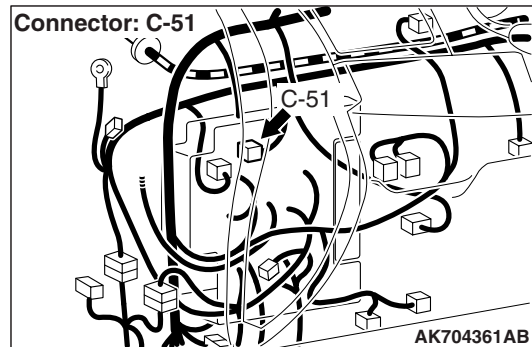
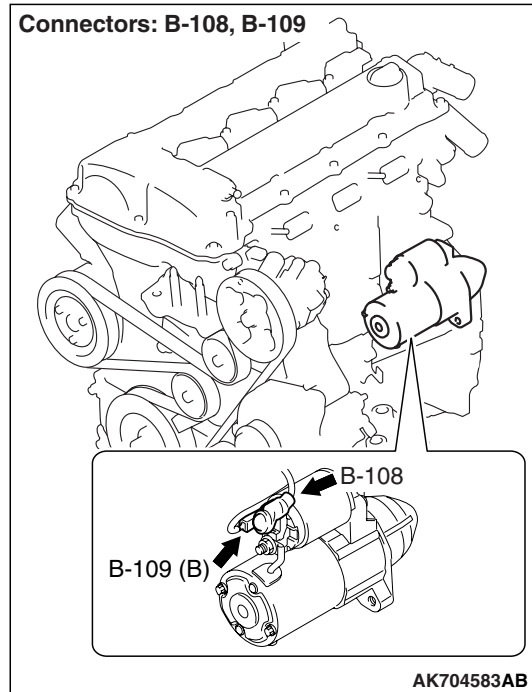
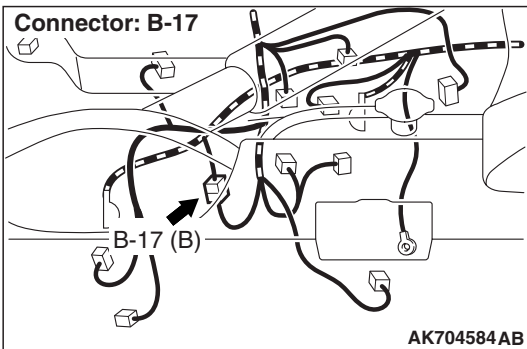
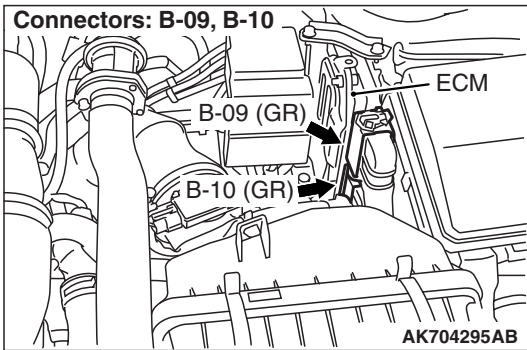
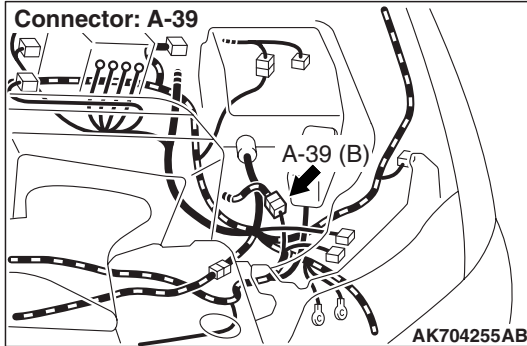
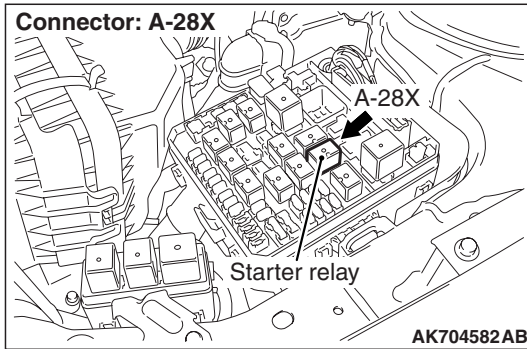

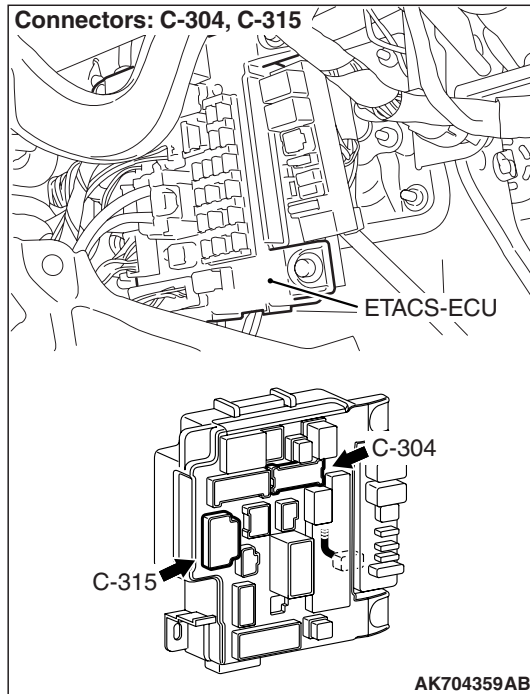

CIRCUIT OPERATION

- If the clutch interlock switch is ON (when the clutch pedal is depressed.) and the ignition switch is turned to "START" position, battery positive voltage is supplied to starter relay coil. With this, the starter relay turns "ON" the battery positive voltage is supplied to the starter motor (terminal No. 1) from the battery.

COMMENT

- Faulty starting system and the related circuit are suspected to be the causes.

TROUBLESHOOTING HINTS (The most likely causes for this case:)

- Battery failed
- Malfunction of the starter motor relay.
- Malfunction of the starter motor.
- Open circuit or short circuit in the starting system or the related circuit or poor contact in the connectors
- Malfunction of the clutch interlock switch.
- Malfunction of the ECM

DIAGNOSIS

Required Special Tools:

- MB991958: Scan Tool (M.U.T.-III Sub Assembly)
 - MB991824: V.C.I.
 - MB991827: USB Cable
 - MB991910: Main Harness A

STEP 1. Using scan tool MB991958, check data list item 79: Cranking signal.

⚠ CAUTION

To prevent damage to scan tool MB991958, always turn the ignition switch to the "LOCK" (OFF) position before connecting or disconnecting scan tool MB991958.

- (1) Connect scan tool MB991958 to the data link connector.
- (2) Turn the ignition switch to the "ON" position.
- (3) Set scan tool MB991958 to the data reading mode for item 79, Cranking Signal.
 - When the engine is stopped, "OFF" will be displayed.
 - When the engine is cranked, "ON" will be displayed.
- (4) Turn the ignition switch to the "LOCK" (OFF) position.

Q: Is the operating properly?

YES : Go to Step 9.

NO : Go to Step 2.

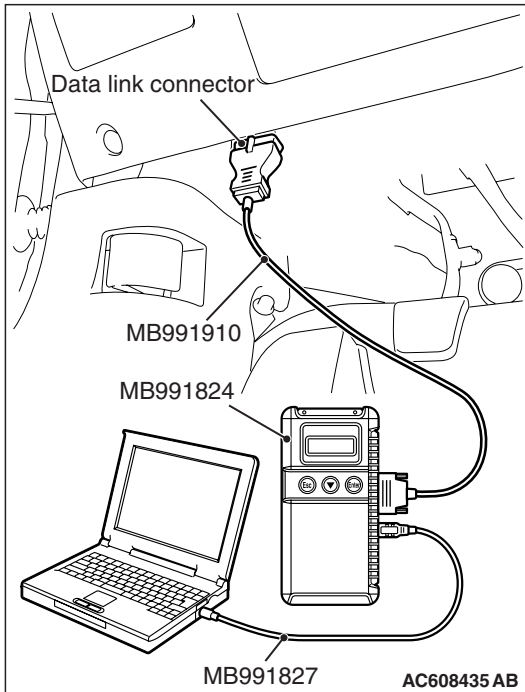

STEP 2. Check harness connector C-304, C-315 at ETACS-ECU connector for damage.

Q: Is the connector in good condition?

YES : Go to Step 3.

NO : Repair or replace it. Refer to GROUP 00E, Harness Connector Inspection [P.00E-2](#). Then confirm that the malfunction symptom is eliminated.

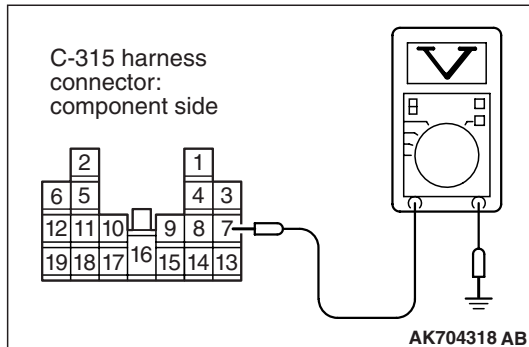

STEP 3. Measure the ignition switch-ST signal voltage at ETACS-ECU harness side connector C-315.

- (1) Disconnect the connector C-315 and measure at the harness side.
- (2) Turn the ignition switch to the "START" position.
- (3) Measure the voltage between terminal No. 7 and ground.
 - Voltage should be battery positive voltage
- (4) Turn the ignition switch to the "LOCK" (OFF) position.

Q: Is battery positive voltage (approximately 12 volts) present?

YES : Go to Step 6.

NO : Go to Step 4.

STEP 4. Check harness connector C-210 ignition switch connector for damage.

Q: Is the connector in good condition?

YES : Go to Step 5.

NO : Repair or replace it. Refer to GROUP 00E, Harness Connector Inspection [P.00E-2](#). Then confirm that the malfunction symptom is eliminated.

STEP 5. Check the ignition switch

Refer to GROUP 54A, Ignition Switch –Inspection –Ignition Switch Continuity Check [P.54A-22](#).

Q: Are there any abnormalities?

YES : Replace the Ignition Switch. Then confirm that the malfunction symptom is eliminated.

NO : Repair harness wire between Ignition Switch connector C-210 (terminal No. 5) and ETACS-ECU connector C-315 (terminal No. 7) because of open circuit or short circuit to ground. Then confirm that the malfunction symptom is eliminated

STEP 6. Check for harness damage between ignition switch connector C-210 (terminal No. 5) and ETACS-ECU connector C-315 (terminal No. 7).

Q: Is the harness wire in good condition?

YES : Go to Step 7.

NO : Repair it. Then confirm that the malfunction symptom is eliminated.

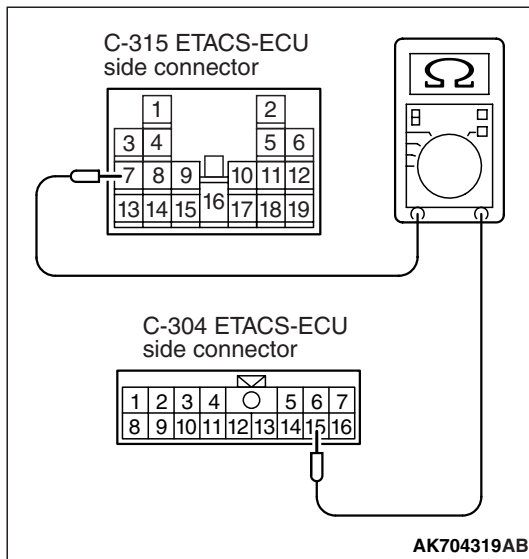

STEP 7. Check for continuity at ETACS-ECU side connector C-304 and C-315.

- (1) Disconnect the connector C-304, C-315 and measure at the ETACS-ECU side.
- (2) Measure the resistance between connector C-304 (terminal No. 15) and connector C-315 (terminal No. 7).
 - Should be less than 2 ohms

Q: Is the harness wire in good condition?

YES : Go to Step 8.

NO : Replace the ETACS-ECU. Then confirm that the malfunction symptom is eliminated.

STEP 8. Check harness connector B-10 ECM connector for damage.

Q: Is the connector in good condition?

YES : Repair harness wire between ETACS-ECU connector C-304 (terminal No. 15) and ECM connector B-10 (terminal No. 105) because of open circuit or short circuit to ground or harness damage. Then confirm that the malfunction symptom is eliminated.

NO : Repair or replace it. Refer to GROUP 00E, Harness Connector Inspection [P.00E-2](#). Then confirm that the malfunction symptom is eliminated.

STEP 9. Check harness connector A-28X at starter relay connector for damage.

Q: Is the connector in good condition?

YES : Go to Step 10.

NO : Repair or replace it. Refer to GROUP 00E, Harness Connector Inspection [P.00E-2](#). Then confirm that the malfunction symptom is eliminated.

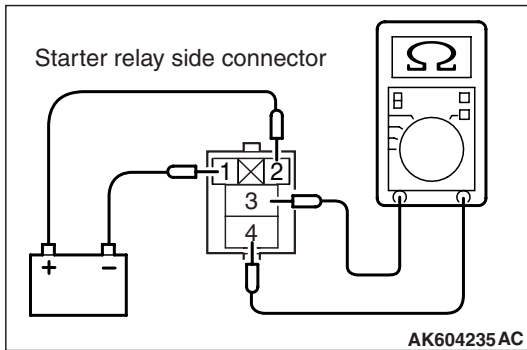
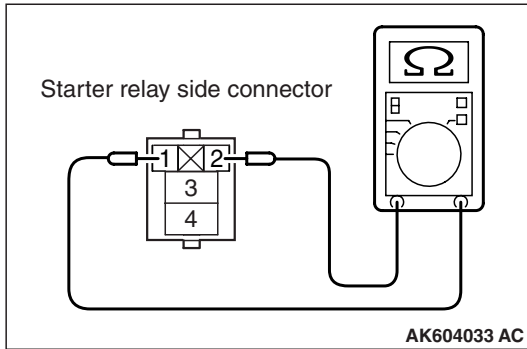
**STEP 10. Check the starter relay.**

- (1) Remove the starter relay.
- (2) Check for continuity between the starter relay terminals No. 1 and No. 2.
 - There should be continuity.

- (3) Use jumper wires to connect starter relay terminal No. 2 to the positive battery terminal and terminal No. 1 to the negative battery terminal.
- (4) Check for continuity between the starter relay terminals No. 3 and No. 4 while connecting and disconnecting the jumper wire at the negative battery terminal.
 - Should be less than 2 ohms. (Negative battery terminal connected)
 - Should be open loop. (Negative battery terminal disconnected)
- (5) Install the starter relay.

Q: Is the measured resistance within the specified range?**YES** : Go to Step 11.**NO** : Replace the starter relay. Then confirm that the malfunction symptom is eliminated.**STEP 11. Check for continuity at starter relay harness side connector A-28X.**

- (1) Disconnect the connector A-28X and measure at the harness side.
- (2) Check for the continuity between terminal No. 1 and ground.
 - Should be less than 2 ohms.

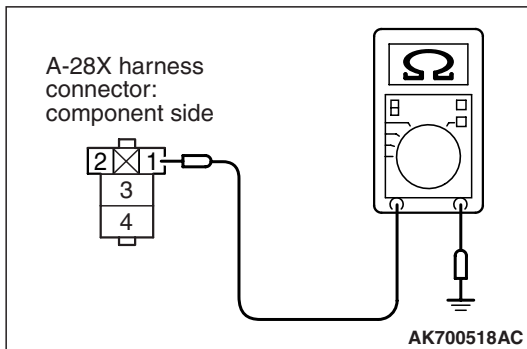
Q: Does continuity exist?**YES** : Go to Step 12.**NO** : Repair harness wire between starter relay connector A-28X (terminal No. 1) and ground because of open circuit or harness damage. Then confirm that the malfunction symptom is eliminated.

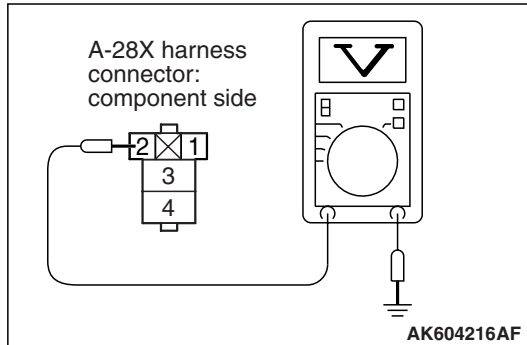

STEP 12. Measure the power supply voltage at starter relay harness side connector A-28X.

- (1) Disconnect the connector A-28X and measure at the harness side.
- (2) Turn the ignition switch to the "START" position.
- (3) Measure the voltage between terminal No. 2 and ground.
 - Voltage should be battery positive voltage
- (4) Turn the ignition switch to the "LOCK" (OFF) position.

Q: Is battery positive voltage (approximately 12 volts) present?

YES : Go to Step 20.

NO : Go to Step 13.

STEP 13. Check harness connector C-51 at clutch interlock switch connector for damage.

Q: Is the connector in good condition?

YES : Go to Step 14.

NO : Repair or replace it. Refer to GROUP 00E, Harness Connector Inspection [P.00E-2](#). Then confirm that the malfunction symptom is eliminated.

STEP 14. Check the clutch interlock switch.

Refer to GROUP 21A, Clutch Pedal Check and Master Cylinder –Inspection –Interlock Switch Operating Check [P.21A-7](#).

Q: Are there any abnormalities?

YES : Repair or replace it. Then confirm that the malfunction symptom is eliminated.

NO : Go to Step 15.

STEP 15. Measure the power supply voltage at clutch interlock switch harness side connector C-51.

- (1) Disconnect the connector C-51 and measure at the harness side.
- (2) Turn the ignition switch to the "START" position.
- (3) Measure the voltage between terminal No. 1 and ground.
 - Voltage should be battery positive voltage
- (4) Turn the ignition switch to the "LOCK" (OFF) position.

Q: Is battery positive voltage (approximately 12 volts) present?

YES : Go to Step 18.

NO : Go to Step 16.

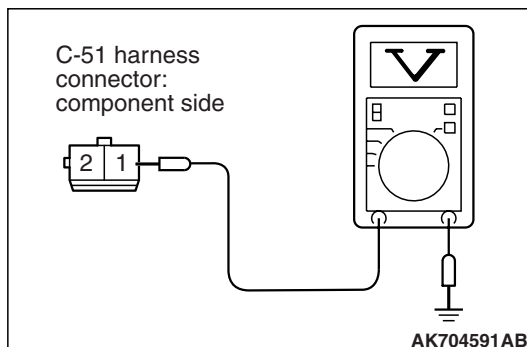

STEP 16. Check harness connector B-10 at ECM connector for damage.

Q: Is the connector in good condition?

YES : Go to Step 17.

NO : Repair or replace it. Refer to GROUP 00E, Harness Connector Inspection [P.00E-2](#). Then confirm that the malfunction symptom is eliminated.

STEP 17. Check for open circuit and short circuit to ground between ECM connector B-10 (terminal No. 106) and clutch interlock switch connector C-51 (terminal No. 1).

Q: Is the harness wire in good condition?

YES : Replace the ECM. When the ECM is replaced, register the ID code. Refer to GROUP 42B, Diagnosis –ID Code Registration Judgment Table <Vehicles with KOS> [P.42B-12](#) or GROUP 42C, Diagnosis –ID Codes Registration Judgment Table <Vehicles with WCM> [P.42C-9](#). Then confirm that the malfunction symptom is eliminated.

NO : Repair it. Then confirm that the malfunction symptom is eliminated.

STEP 18. Check for open circuit and short circuit to ground between clutch interlock switch connector C-51 (terminal No. 2) and starter relay A-28X (terminal No. 2).

Q: Is the harness wire in good condition?

YES : Go to Step 19.

NO : Repair it. Then confirm that the malfunction symptom is eliminated.

STEP 19. Check harness connector B-09 at ECM connector for damage.

Q: Is the connector in good condition?

YES : Check harness connector A-39 at intermediate connector for damage, and repair or replace as required. Refer to, GROUP 00E, Harness Connector Inspection [P.00E-2](#). If intermediate connector is in good condition, repair harness wire between ECM connector B-09 (terminal No. 6) and starter relay connector A-28X (terminal No. 2) because of short circuit to ground. Then confirm that the malfunction symptom is eliminated.

NO : Repair or replace it. Refer to GROUP 00E, Harness Connector Inspection [P.00E-2](#). Then confirm that the malfunction symptom is eliminated.

STEP 20. Check harness connector B-109 at starter connector for damage.

Q: Is the connector in good condition?

YES : Go to Step 21.

NO : Repair or replace it. Refer to GROUP 00E, Harness Connector Inspection [P.00E-2](#). Then confirm that the malfunction symptom is eliminated.

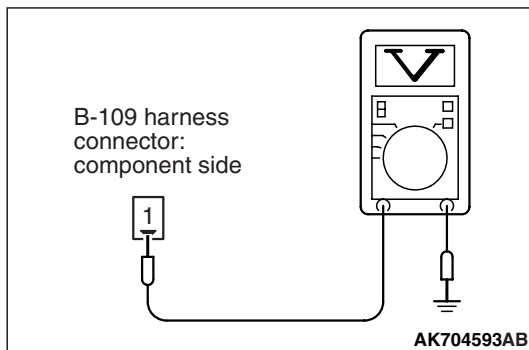

STEP 21. Measure the power supply voltage at starter harness side connector B-109.

- (1) Disconnect the connector B-109 and measure at the harness side.
- (2) Turn the ignition switch to the "START" position.
- (3) Measure the voltage between terminal No. 1 and ground.
 - Voltage should be battery positive voltage
- (4) Turn the ignition switch to the "LOCK" (OFF) position.

Q: Is battery positive voltage (approximately 12 volts) present?

YES : Go to Step 26.

NO : Go to Step 22.

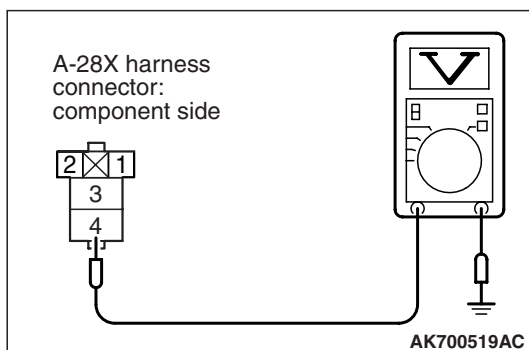

STEP 22. Measure the power supply voltage at starter relay harness side connector A-28X.

- (1) Disconnect the connector A-28X and measure at the harness side.
- (2) Measure the voltage between terminal No. 4 and ground.
 - Voltage should be battery positive voltage

Q: Is battery positive voltage (approximately 12 volts) present?

YES : Go to Step 23.

NO : Repair harness wire between fusible link (24) and starter relay connector A-28X (terminal No. 4) because of open circuit or short circuit to ground. Then confirm that the malfunction symptom is eliminated.

STEP 23. Check for open circuit and short circuit to ground between starter relay connector A-28X (terminal No. 3) and starter connector B-109 (terminal No. 1)

NOTE: Check harness after checking intermediate connector A-39, B-17. If intermediate connector is damaged, repair or replace it. After to GROUP 00E, Harness Connector Inspection [P.00E-2](#). Then check that the malfunction is eliminated.

Q: Is the harness wire in good condition?

YES : Go to Step 24.

NO : Repair it. Then confirm that the malfunction symptom is eliminated.

STEP 24. Check harness connector B-10 at ECM connector and harness connector C-51 at clutch interlock switch connector for damage.

Q: Is the connector in good condition?

YES : Go to Step 25.

NO : Repair or replace it. Refer to GROUP 00E, Harness Connector Inspection [P.00E-2](#). Then confirm that the malfunction symptom is eliminated.

STEP 25. Check for harness damage between ECM connector B-10 (terminal No. 106) and clutch interlock switch connector C-51 (terminal No. 2).

Q: Is the harness wire in good condition?

YES : Repair harness wire between clutch interlock switch connector C-51 (terminal No. 2) and starter relay connector A-28X (terminal No. 2) because of harness damage. Then confirm that the malfunction symptom is eliminated.

NO : Repair it. Then confirm that the malfunction symptom is eliminated.

STEP 26. Check for harness damage between starter relay connector A-28X (terminal No. 3) and starter connector B-109 (terminal No. 1)

NOTE: Check harness after checking intermediate connector A-39, B-17. If intermediate connector is damaged, repair or replace it. After to GROUP 00E, Harness Connector Inspection [P.00E-2](#). Then check that the malfunction is eliminated.

Q: Is the harness wire in good condition?

YES : Go to Step 27.

NO : Repair it. Then confirm that the malfunction symptom is eliminated.

STEP 27. Check for harness damage between fusible link (24) and starter relay connector A-28X (terminal No. 4)

Q: Is the harness wire in good condition?

YES : Go to Step 28.

NO : Repair it. Then confirm that the malfunction symptom is eliminated.

STEP 28. Check harness connector B-108 at starter connector for damage.

Q: Is the connector in good condition?

YES : Go to Step 29.

NO : Repair or replace it. Refer to GROUP 00E, Harness Connector Inspection [P.00E-2](#). Then confirm that the malfunction symptom is eliminated.

STEP 29. Check for open circuit and short circuit to ground and harness damage between battery and starter connector B-108 (terminal No. 1)

Q: Is the harness wire in good condition?

YES : Replace the starter.

NO : Repair it. Then confirm that the malfunction symptom is eliminated.

Inspection procedure 25: Ignition switch-ST system and starter relay system <TC-SST>

STARTING SYSTEM CIRCUIT <TC-SST>

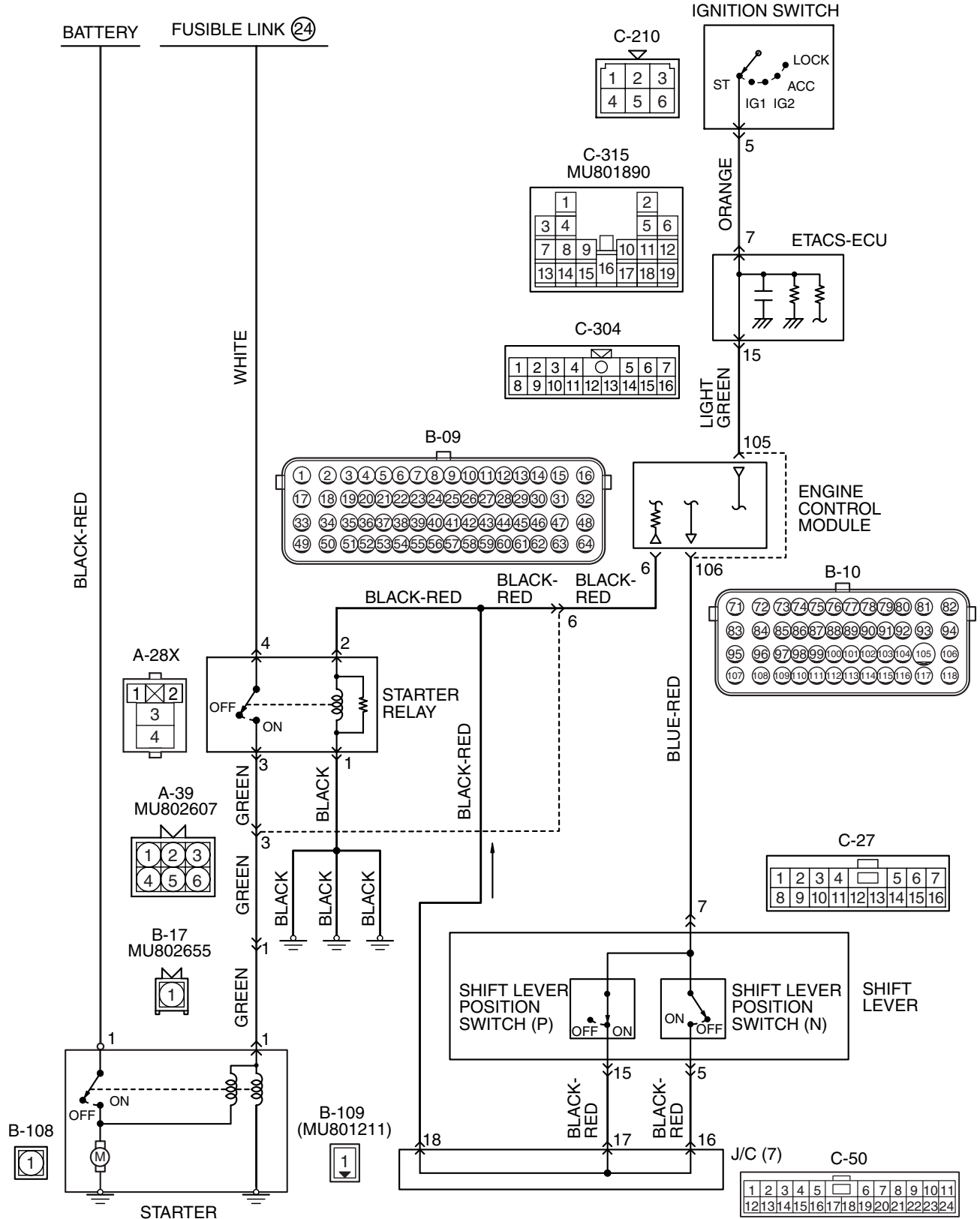

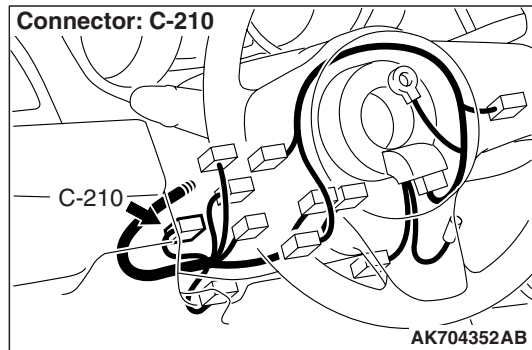
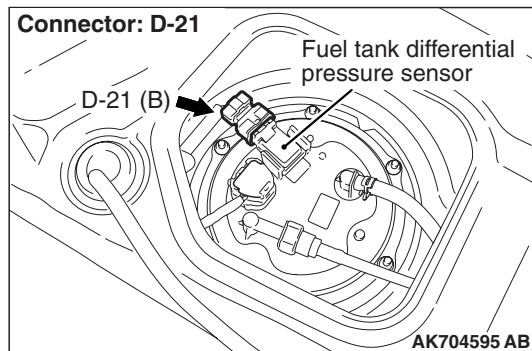
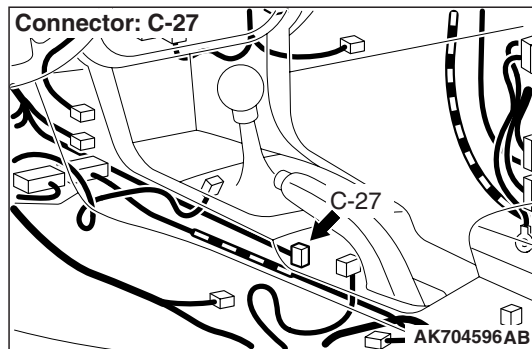
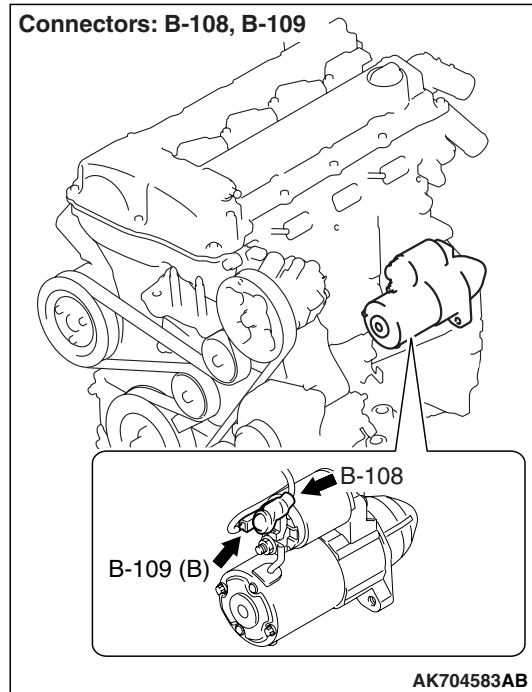
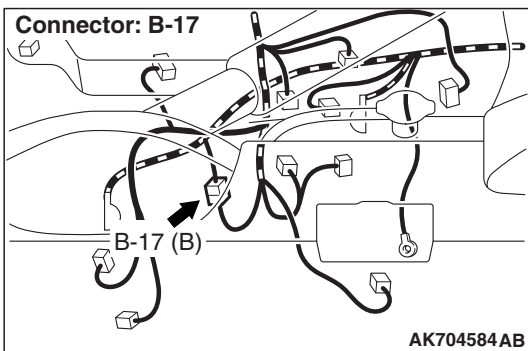
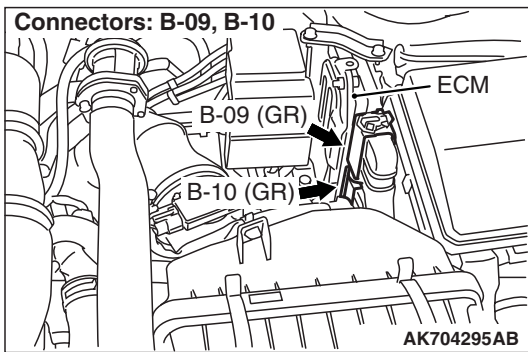
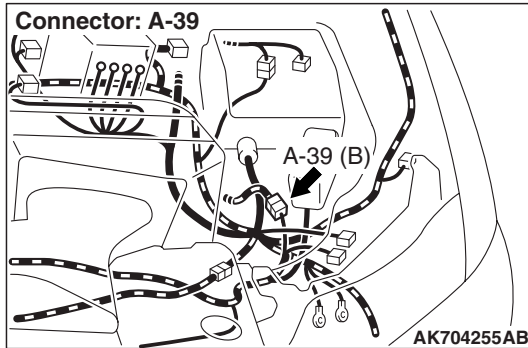
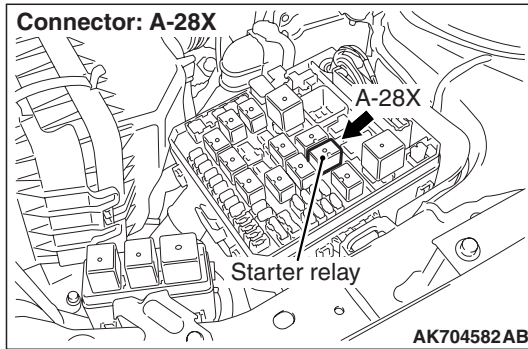

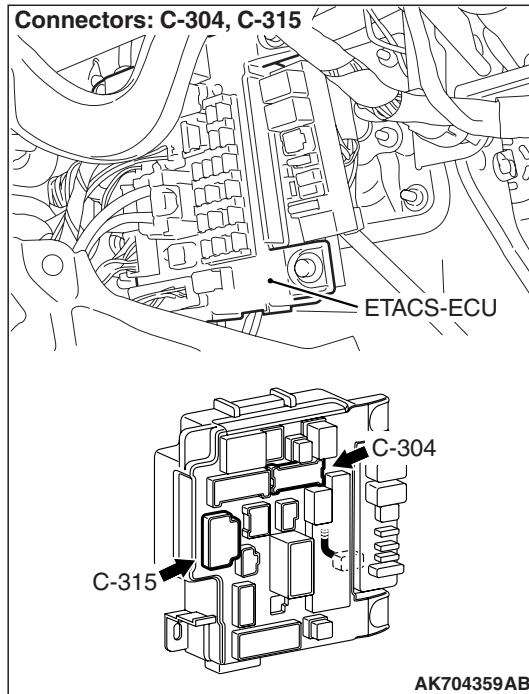

CIRCUIT OPERATION

- If the shift lever is moved to "P" or "N" position and the ignition switch is turned to "START" position, battery positive voltage is supplied to starter relay coil. With this, the starter relay turns "ON" the battery positive voltage is supplied to the starter motor (terminal No. 1) from the battery.

COMMENT

- Faulty starting system and the related circuit are suspected to be the causes.

TROUBLESHOOTING HINTS (The most likely causes for this case:)

- Battery failed
- Malfunction of the starter motor relay.
- Malfunction of the starter motor.
- Open or shorted starting system circuit, harness damage, or connector damage.
- Malfunction of the shift lever.
- Malfunction of the ECM

DIAGNOSIS

Required Special Tools:

- MB991958: Scan Tool (M.U.T.-III Sub Assembly)
 - MB991824: V.C.I.
 - MB991827: USB Cable
 - MB991910: Main Harness A

STEP 1. Using scan tool MB991958, check data list item 79: Cranking signal.

⚠ CAUTION

To prevent damage to scan tool MB991958, always turn the ignition switch to the "LOCK" (OFF) position before connecting or disconnecting scan tool MB991958.

- (1) Connect scan tool MB991958 to the data link connector.
- (2) Turn the ignition switch to the "ON" position.
- (3) Set scan tool MB991958 to the data reading mode for item 79, Cranking Signal.
 - When the engine is stopped, "OFF" will be displayed.
 - When the engine is cranked, "ON" will be displayed.
- (4) Turn the ignition switch to the "LOCK" (OFF) position.

Q: Is the operating properly?

YES : Go to Step 9.

NO : Go to Step 2.

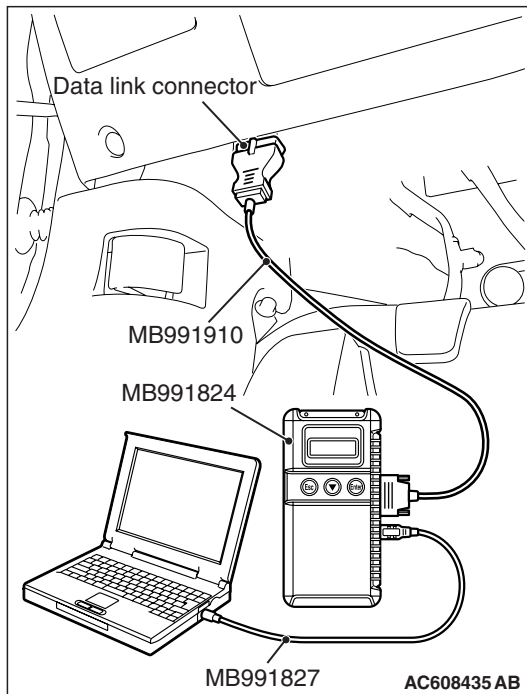

STEP 2. Check harness connector C-304, C-315 at ETACS-ECU connector for damage.

Q: Is the connector in good condition?

YES : Go to Step 3.

NO : Repair or replace it. Refer to GROUP 00E, Harness Connector Inspection [P.00E-2](#). Then confirm that the malfunction symptom is eliminated.

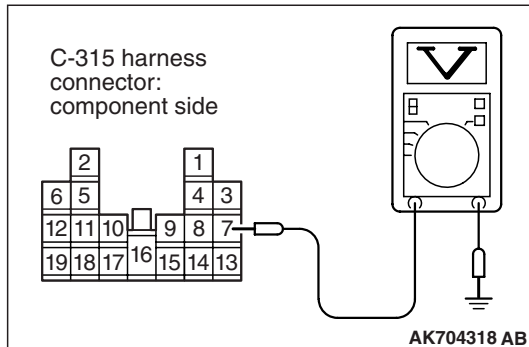

STEP 3. Measure the ignition switch-ST signal voltage at ETACS-ECU harness side connector C-315.

- (1) Disconnect the connector C-315 and measure at the harness side.
- (2) Turn the ignition switch to the "START" position.
- (3) Measure the voltage between terminal No. 7 and ground.
 - Voltage should be battery positive voltage
- (4) Turn the ignition switch to the "LOCK" (OFF) position.

Q: Is battery positive voltage (approximately 12 volts) present?

YES : Go to Step 6.

NO : Go to Step 4.

STEP 4. Check harness connector C-210 ignition switch connector for damage.

Q: Is the connector in good condition?

YES : Go to Step 5.

NO : Repair or replace it. Refer to GROUP 00E, Harness Connector Inspection [P.00E-2](#). Then confirm that the malfunction symptom is eliminated.

STEP 5. Check the ignition switch

Refer to GROUP 54A, Ignition Switch –Inspection –Ignition Switch Continuity Check [P.54A-22](#).

Q: Are there any abnormalities?

YES : Replace the Ignition Switch. Then confirm that the malfunction symptom is eliminated.

NO : Repair harness wire between Ignition Switch connector C-210 (terminal No. 5) and ETACS-ECU connector C-315 (terminal No. 7) because of open circuit or short circuit to ground. Then confirm that the malfunction symptom is eliminated

STEP 6. Check for harness damage between ignition switch connector C-210 (terminal No. 5) and ETACS-ECU connector C-315 (terminal No. 7).

Q: Is the harness wire in good condition?

YES : Go to Step 7.

NO : Repair it. Then confirm that the malfunction symptom is eliminated.

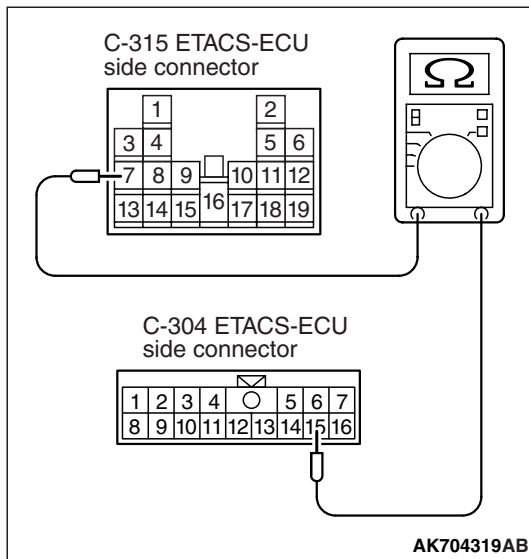

STEP 7. Check for continuity at ETACS-ECU side connector C-304 and C-315.

- (1) Disconnect the connector C-304, C-315 and measure at the ETACS-ECU side.
- (2) Measure the resistance between connector C-304 (terminal No. 15) and connector C-315 (terminal No. 7).
 - Should be less than 2 ohms

Q: Is the harness wire in good condition?

YES : Go to Step 8.

NO : Replace the ETACS-ECU. Then confirm that the malfunction symptom is eliminated.

STEP 8. Check harness connector B-10 ECM connector for damage.

Q: Is the connector in good condition?

YES : Repair harness wire between ETACS-ECU connector C-304 (terminal No. 15) and ECM connector B-10 (terminal No. 105) because of open circuit or short circuit to ground or harness damage. Then confirm that the malfunction symptom is eliminated.

NO : Repair or replace it. Refer to GROUP 00E, Harness Connector Inspection [P.00E-2](#). Then confirm that the malfunction symptom is eliminated.

STEP 9. Check harness connector A-28X at starter relay connector for damage.

Q: Is the connector in good condition?

YES : Go to Step 10.

NO : Repair or replace it. Refer to GROUP 00E, Harness Connector Inspection [P.00E-2](#). Then confirm that the malfunction symptom is eliminated.

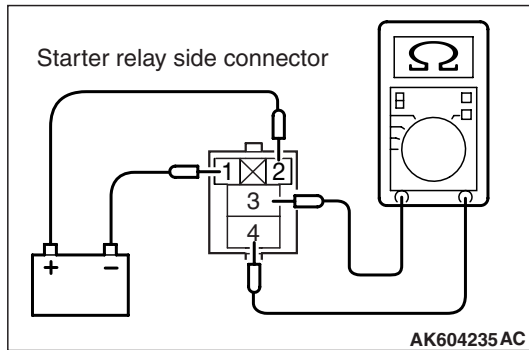
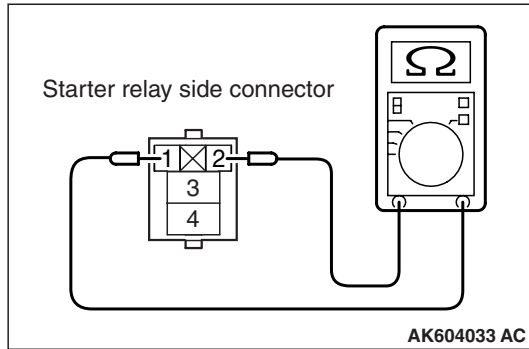
**STEP 10. Check the starter relay.**

- (1) Remove the starter relay.
- (2) Check for continuity between the starter relay terminals No. 1 and No. 2.
 - There should be continuity.

- (3) Use jumper wires to connect starter relay terminal No. 2 to the positive battery terminal and terminal No. 1 to the negative battery terminal.
- (4) Check for continuity between the starter relay terminals No. 3 and No. 4 while connecting and disconnecting the jumper wire at the negative battery terminal.
 - Should be less than 2 ohms. (Negative battery terminal connected)
 - Should be open loop. (Negative battery terminal disconnected)
- (5) Install the starter relay.

Q: Is the measured resistance within the specified range?**YES :** Go to Step 11.**NO :** Replace the starter relay. Then confirm that the malfunction symptom is eliminated.**STEP 11. Check for continuity at starter relay harness side connector A-28X.**

- (1) Disconnect the connector A-28X and measure at the harness side.
- (2) Check for the continuity between terminal No. 1 and ground.
 - Should be less than 2 ohms.

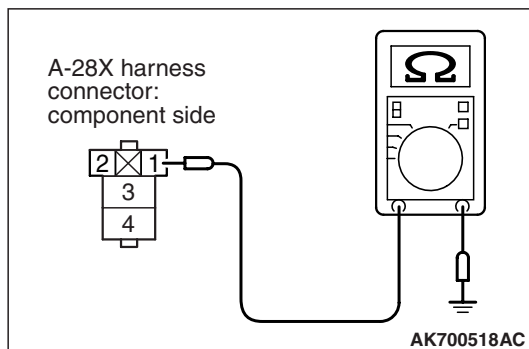
Q: Does continuity exist?**YES :** Go to Step 12.**NO :** Repair harness wire between starter relay connector A-28X (terminal No. 1) and ground because of open circuit or harness damage. Then confirm that the malfunction symptom is eliminated.

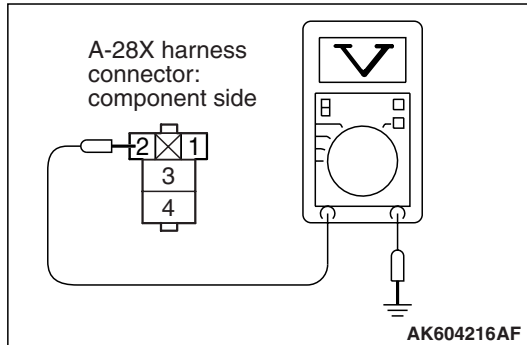

STEP 12. Measure the power supply voltage at starter relay harness side connector A-28X.

- (1) Disconnect the connector A-28X and measure at the harness side.
- (2) Turn the ignition switch to the "START" position.
- (3) Measure the voltage between terminal No. 2 and ground.
 - Voltage should be battery positive voltage
- (4) Turn the ignition switch to the "LOCK" (OFF) position.

Q: Is battery positive voltage (approximately 12 volts) present?

YES : Go to Step 20.

NO : Go to Step 13.

STEP 13. Check harness connector C-27 at shift lever connector for damage.

Q: Is the connector in good condition?

YES : Go to Step 14.

NO : Repair or replace it. Refer to GROUP 00E, Harness Connector Inspection [P.00E-2](#). Then confirm that the malfunction symptom is eliminated.

STEP 14. Check the shift lever.

Refer to GROUP 22C, On-vehicle Service –Shift Lever Operation Check [P.22C-330](#).

Q: Are there any abnormalities?

YES : Repair or replace it. Then confirm that the malfunction symptom is eliminated.

NO : Go to Step 15.

STEP 15. Measure the power supply voltage at shift lever harness side connector C-27.

- (1) Disconnect the connector C-27 and measure at the harness side.
- (2) Turn the ignition switch to the "START" position.
- (3) Measure the voltage between terminal No. 7 and ground.
 - Voltage should be battery positive voltage
- (4) Turn the ignition switch to the "LOCK" (OFF) position.

Q: Is battery positive voltage (approximately 12 volts) present?

YES : Go to Step 18.

NO : Go to Step 16.

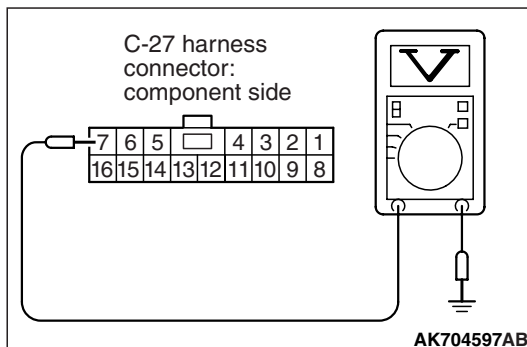

STEP 16. Check harness connector B-10 at ECM connector for damage.

Q: Is the connector in good condition?

YES : Go to Step 17.

NO : Repair or replace it. Refer to GROUP 00E, Harness Connector Inspection [P.00E-2](#). Then confirm that the malfunction symptom is eliminated.

STEP 17. Check for open circuit and short circuit to ground between ECM connector B-10 (terminal No. 106) and shift lever connector C-27 (terminal No. 7).

Q: Is the harness wire in good condition?

YES : Replace the ECM. When the ECM is replaced, register the ID code. Refer to GROUP 42B, Diagnosis –ID Code Registration Judgment Table <Vehicles with KOS> [P.42B-12](#) or GROUP 42C, Diagnosis –ID Codes Registration Judgment Table <Vehicles with WCM> [P.42C-9](#). Then confirm that the malfunction symptom is eliminated.

NO : Repair it. Then confirm that the malfunction symptom is eliminated.

STEP 18. Check for open circuit and short circuit to ground between shift lever connector C-27 (terminal No. 5, No. 15) and starter relay A-28X (terminal No. 2).

NOTE: Check harness after checking intermediate connector C-50. If intermediate connector is damaged, repair or replace it. After to GROUP 00E, Harness Connector Inspection [P.00E-2](#). Then check that the malfunction is eliminated.

Q: Is the harness wire in good condition?

YES : Go to Step 19.

NO : Repair it. Then confirm that the malfunction symptom is eliminated.

STEP 19. Check harness connector B-09 at ECM connector for damage.

Q: Is the connector in good condition?

YES : Check harness connector A-39 at intermediate connector for damage, and repair or replace as required. Refer to, GROUP 00E, Harness Connector Inspection [P.00E-2](#). If intermediate connector is in good condition, repair harness wire between ECM connector B-09 (terminal No. 6) and starter relay connector A-28X (terminal No. 2) because of short circuit to ground. Then confirm that the malfunction symptom is eliminated.

NO : Repair or replace it. Refer to GROUP 00E, Harness Connector Inspection [P.00E-2](#). Then confirm that the malfunction symptom is eliminated.

STEP 20. Check harness connector B-109 at starter connector for damage.

Q: Is the connector in good condition?

YES : Go to Step 21.

NO : Repair or replace it. Refer to GROUP 00E, Harness Connector Inspection [P.00E-2](#). Then confirm that the malfunction symptom is eliminated.

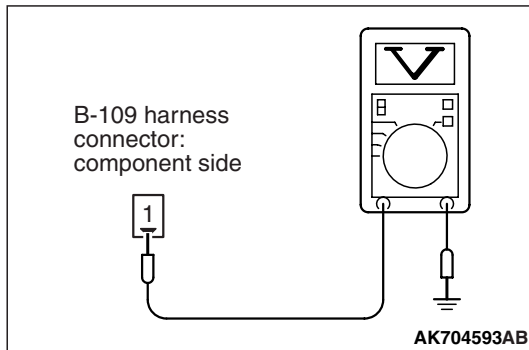

STEP 21. Measure the power supply voltage at starter harness side connector B-109.

- (1) Disconnect the connector B-109 and measure at the harness side.
- (2) Turn the ignition switch to the "START" position.
- (3) Measure the voltage between terminal No. 1 and ground.
 - Voltage should be battery positive voltage
- (4) Turn the ignition switch to the "LOCK" (OFF) position.

Q: Is battery positive voltage (approximately 12 volts) present?

YES : Go to Step 26.

NO : Go to Step 22.

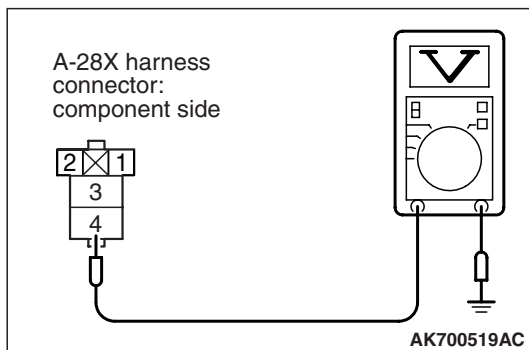

STEP 22. Measure the power supply voltage at starter relay harness side connector A-28X.

- (1) Disconnect the connector A-28X and measure at the harness side.
- (2) Measure the voltage between terminal No. 4 and ground.
 - Voltage should be battery positive voltage

Q: Is battery positive voltage (approximately 12 volts) present?

YES : Go to Step 23.

NO : Repair harness wire between fusible link (24) and starter relay connector A-28X (terminal No. 4) because of open circuit or short circuit to ground. Then confirm that the malfunction symptom is eliminated.

STEP 23. Check for open circuit and short circuit to ground between starter relay connector A-28X (terminal No. 3) and starter connector B-109 (terminal No. 1)

NOTE: Check harness after checking intermediate connector A-39, B-17. If intermediate connector is damaged, repair or replace it. After to GROUP 00E, Harness Connector Inspection [P.00E-2](#). Then check that the malfunction is eliminated.

Q: Is the harness wire in good condition?

YES : Go to Step 24.

NO : Repair it. Then confirm that the malfunction symptom is eliminated.

STEP 24. Check harness connector B-10 at ECM connector and harness connector C-27 at shift lever connector for damage.

Q: Is the connector in good condition?

YES : Go to Step 25.

NO : Repair or replace it. Refer to GROUP 00E, Harness Connector Inspection [P.00E-2](#). Then confirm that the malfunction symptom is eliminated.

STEP 25. Check for harness damage between ECM connector B-10 (terminal No. 106) and shift lever connector C-27 (terminal No. 7).

Q: Is the harness wire in good condition?

YES : Check harness connector C-50 at intermediate connector for damage, and repair or replace as required. Refer to, GROUP 00E, Harness Connector Inspection [P.00E-2](#). If intermediate connector is in good condition, repair harness wire between shift lever connector C-27 (terminal No. 5, No. 15) and starter relay connector A-28X (terminal No. 2) because of harness damage. Then confirm that the malfunction symptom is eliminated.

NO : Repair it. Then confirm that the malfunction symptom is eliminated.

STEP 26. Check for harness damage between starter relay connector A-28X (terminal No. 3) and starter connector B-109 (terminal No. 1)

NOTE: Check harness after checking intermediate connector A-39, B-17. If intermediate connector is damaged, repair or replace it. After to GROUP 00E, Harness Connector Inspection [P.00E-2](#). Then check that the malfunction is eliminated.

Q: Is the harness wire in good condition?

YES : Go to Step 27.

NO : Repair it. Then confirm that the malfunction symptom is eliminated.

STEP 27. Check for harness damage between fusible link (24) and starter relay connector A-28X (terminal No. 4)

Q: Is the harness wire in good condition?

YES : Go to Step 28.

NO : Repair it. Then confirm that the malfunction symptom is eliminated.

STEP 28. Check harness connector B-108 at starter connector for damage.

Q: Is the connector in good condition?

YES : Go to Step 29.

NO : Repair or replace it. Refer to GROUP 00E, Harness Connector Inspection [P.00E-2](#). Then confirm that the malfunction symptom is eliminated.

STEP 29. Check for open circuit and short circuit to ground and harness damage between battery and starter connector B-108 (terminal No. 1)

Q: Is the harness wire in good condition?

YES : Replace the starter.

NO : Repair it. Then confirm that the malfunction symptom is eliminated.

Inspection procedure 26: Ignition circuit system

IGNITION CIRCUIT

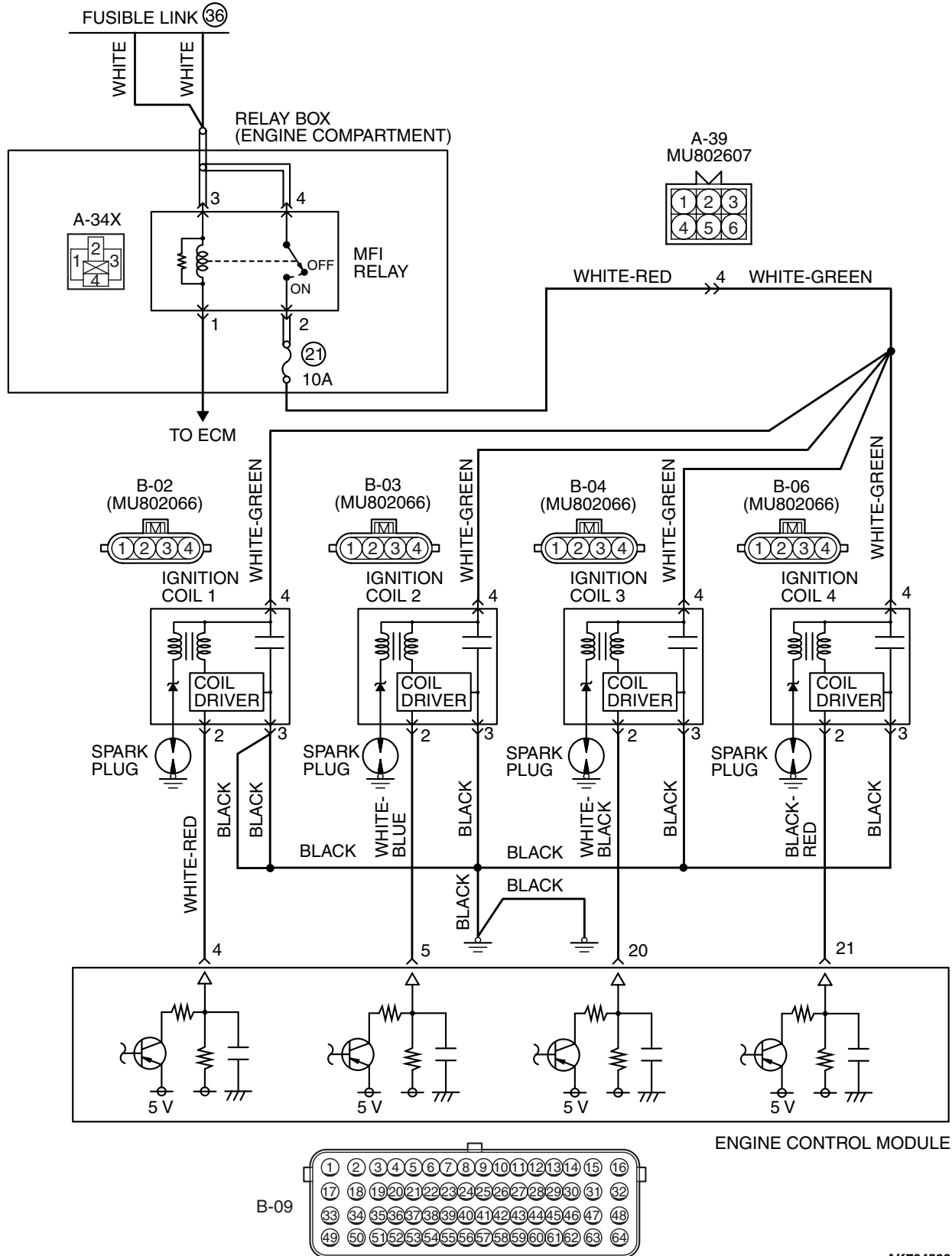

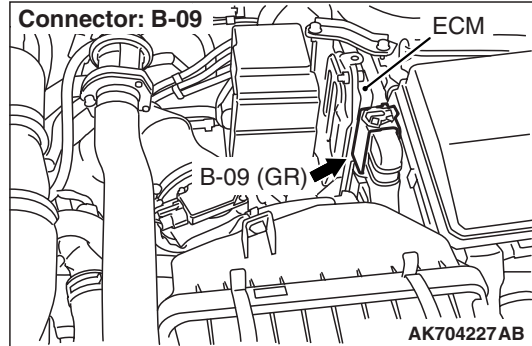
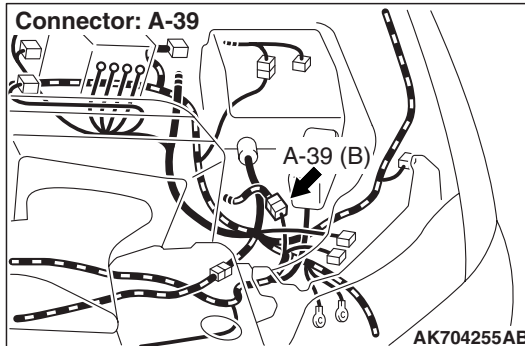
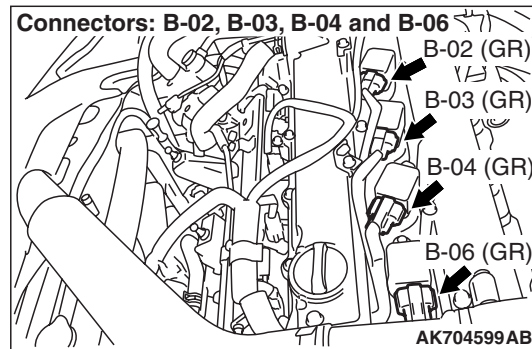
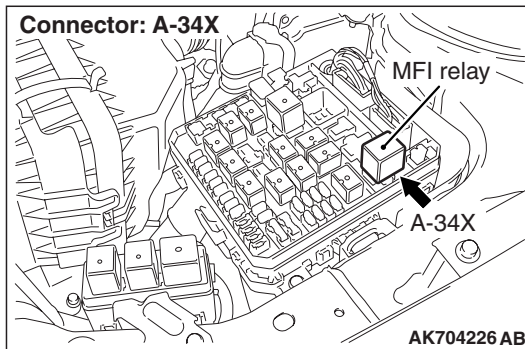

CIRCUIT OPERATION

- The battery positive voltage is applied from the MFI relay (terminal No. 2) to the ignition coil (terminal No. 4) and is grounded to the vehicle body via the ignition coil (terminal No. 5).
- A power voltage of 5 V is applied to the ignition coil (terminal No. 2) from the ECM (terminal No. 4, No. 5, No. 20 and No. 21).

COMMENT

- When the ECM turn the power transistor in the unit to OFF, the battery positive voltage is applied to the power transistor in the ignition coil, resulting that the power transistor is ON. And, when the ECM turns the power transistor in the unit to ON, the power transistor in the ignition coil will be turned OFF.

- When the power transistor in the ignition coil is turned to ON with any signal from the ECM, the primary voltage will be applied through the ignition coil. When the power transistor in the ignition coil is turned OFF, the primary current is blocked and high voltage is generated in the secondary coil.

TROUBLESHOOTING HINTS (The most likely causes for this case:)

- Malfunction of the ignition coil.
- Open or shorted ignition circuit, harness damage, or connector damage.
- Malfunction of the ECM.

DIAGNOSIS

STEP 1. Check the ignition coil.

Refer to GROUP 16, Ignition System –On-vehicle Service – Ignition Coil Check [P.16-36](#).

Q: Are there any abnormalities?

YES : Replace the ignition coil. Then confirm that the malfunction symptom is eliminated.

NO : Go to Step 2.

STEP 2. Check harness connector B-02, B-03, B-04 and B-06 at ignition coil for damage.

Q: Is the harness connector in good condition?

YES : Go to Step 3.

NO : Repair or replace it. Refer to GROUP 00E, Harness Connector Inspection [P.00E-2](#). Then confirm that the malfunction symptom is eliminated.

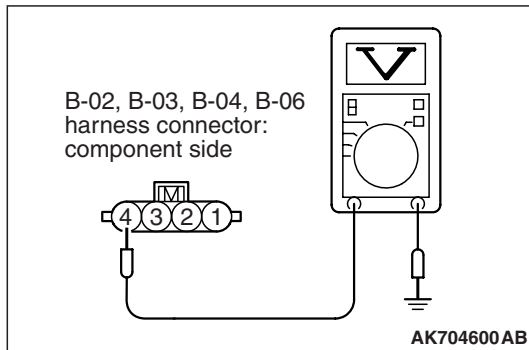

STEP 3. Measure the power supply voltage at ignition coil connectors B-02, B-03, B-04 and B-06.

- (1) Disconnect the connector B-02, B-03, B-04 and B-06 and measure at the harness side.
- (2) Turn the ignition switch to the "ON" position.
- (3) Measure the voltage between terminal No. 4 and ground.
 - Voltage should be battery positive voltage.
- (4) Turn the ignition switch to the "LOCK" (OFF) position.

Q: Is battery positive voltage (approximately 12 volts) present?

YES : Go to Step 4.

NO : Check harness connector A-39 at intermediate connector for damage, and repair or replace as required. Refer to, GROUP 00E, Harness Connector Inspection [P.00E-2](#). If intermediate connector is in good condition, repair harness wire between MFI relay connector A-34X (terminal No. 2) and ignition coil connectors B-02, B-03, B-04 and B-06 (terminal No. 4) because of open circuit or short circuit to ground. Then confirm that the malfunction symptom is eliminated.

STEP 4. Check the circuit at ignition coil harness side connector B-02, B-03, B-04 and B-06.

- (1) Disconnect the connectors B-02, B-03, B-04 and B-06 and measure at the harness side.
- (2) Engine: 3,000 r/min
- (3) Measure the voltage between terminal No. 2 and ground.
 - Voltage should be 0.3 and 3.0 volts.
- (4) Turn the ignition switch to the "LOCK" (OFF) position.

Q: Is the measured voltage between 0.3 and 3.0 volts?

YES : Go to Step 7.

NO : Go to Step 5.

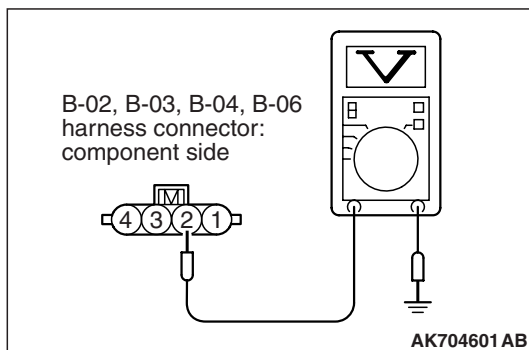

STEP 5. Check harness connector B-09 at ECM for damage.

Q: Is the harness connector in good condition?

YES : Go to Step 6.

NO : Repair or replace it. Refer to GROUP 00E, Harness Connector Inspection [P.00E-2](#). Then confirm that the malfunction symptom is eliminated.

STEP 6. Check for open circuit and short circuit to ground between ignition coil connector and ECM connector.

- a. Check the harness wire between ignition coil connector B-02 (terminal No. 2) and ECM connector B-09 (terminal No. 4) at ignition coil 1.
- b. Check the harness wire between ignition coil connector B-03 (terminal No. 2) and ECM connector B-09 (terminal No. 5) at ignition coil 2.
- c. Check the harness wire between ignition coil connector B-04 (terminal No. 2) and ECM connector B-09 (terminal No. 20) at ignition coil 3.
- d. Check the harness wire between ignition coil connector B-06 (terminal No. 2) and ECM connector B-09 (terminal No. 21) at ignition coil 4.

Q: Is the harness wire in good condition?

YES : Replace the ECM. When the ECM is replaced, register the ID code. Refer to GROUP 42B, Diagnosis –ID Code Registration Judgment Table <Vehicles with KOS> [P.42B-12](#) or GROUP 42C, Diagnosis –ID Codes Registration Judgment Table <Vehicles with WCM> [P.42C-9](#). Then confirm that the malfunction symptom is eliminated.

NO : Repair it. Then confirm that the malfunction symptom is eliminated.

STEP 7. Check for continuity at ignition coil harness side connector B-02, B-03, B-04 and B-06.

- (1) Disconnect the connectors B-02, B-03, B-04 and B-06 and measure at the harness side.
- (2) Check for the continuity between terminal No. 3 and ground.
 - Should be less than 2 ohms.

Q: Does continuity exist?

YES : Go to Step 8.

NO : Repair harness wire between ignition coil connectors B-02, B-03, B-04 and B-06 (terminal No. 3) and ground because of open circuit or harness damage. Then confirm that the malfunction symptom is eliminated.

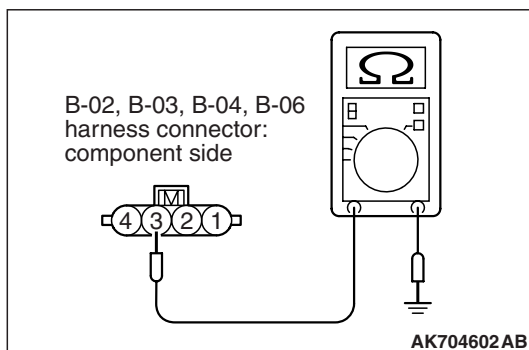

STEP 8. Check for harness damage between MFI relay connector A-34X (terminal No. 2) and ignition coil connector B-02, B-03, B-04 and B-06 (terminal No. 4)

NOTE: Check harness after checking intermediate connector A-39. If intermediate connector is damaged, repair or replace it. After to GROUP 00E, Harness Connector Inspection P.00E-2. Then check that the malfunction is eliminated.

Q: Is the harness wire in good condition?

YES : Go to Step 9.

NO : Repair it. Then confirm that the malfunction symptom is eliminated.

STEP 9. Check for harness damage between ignition coil connector and ECM connector.

- a. Check the harness wire between ignition coil connector B-02 (terminal No. 2) and ECM connector B-09 (terminal No. 151) at ignition coil 1.
- b. Check the harness wire between ignition coil connector B-03 (terminal No. 2) and ECM connector B-09 (terminal No. 143) at ignition coil 2.
- c. Check the harness wire between ignition coil connector B-04 (terminal No. 2) and ECM connector B-09 (terminal No. 150) at ignition coil 3.
- d. Check the harness wire between ignition coil connector B-06 (terminal No. 2) and ECM connector B-09 (terminal No. 148) at ignition coil 4.

Q: Is the harness wire in good condition?

YES : Replace the ECM. When the ECM is replaced, register the ID code. Refer to GROUP 42B, Diagnosis –ID Code Registration Judgment Table <Vehicles with KOS> P.42B-12 or GROUP 42C, Diagnosis –ID Codes Registration Judgment Table <Vehicles with WCM> P.42C-9. Then confirm that the malfunction symptom is eliminated.

NO : Repair it. Then confirm that the malfunction symptom is eliminated.

Inspection procedure 27: A/C system

A/C COMPRESSOR CLUTCH RELAY CIRCUIT

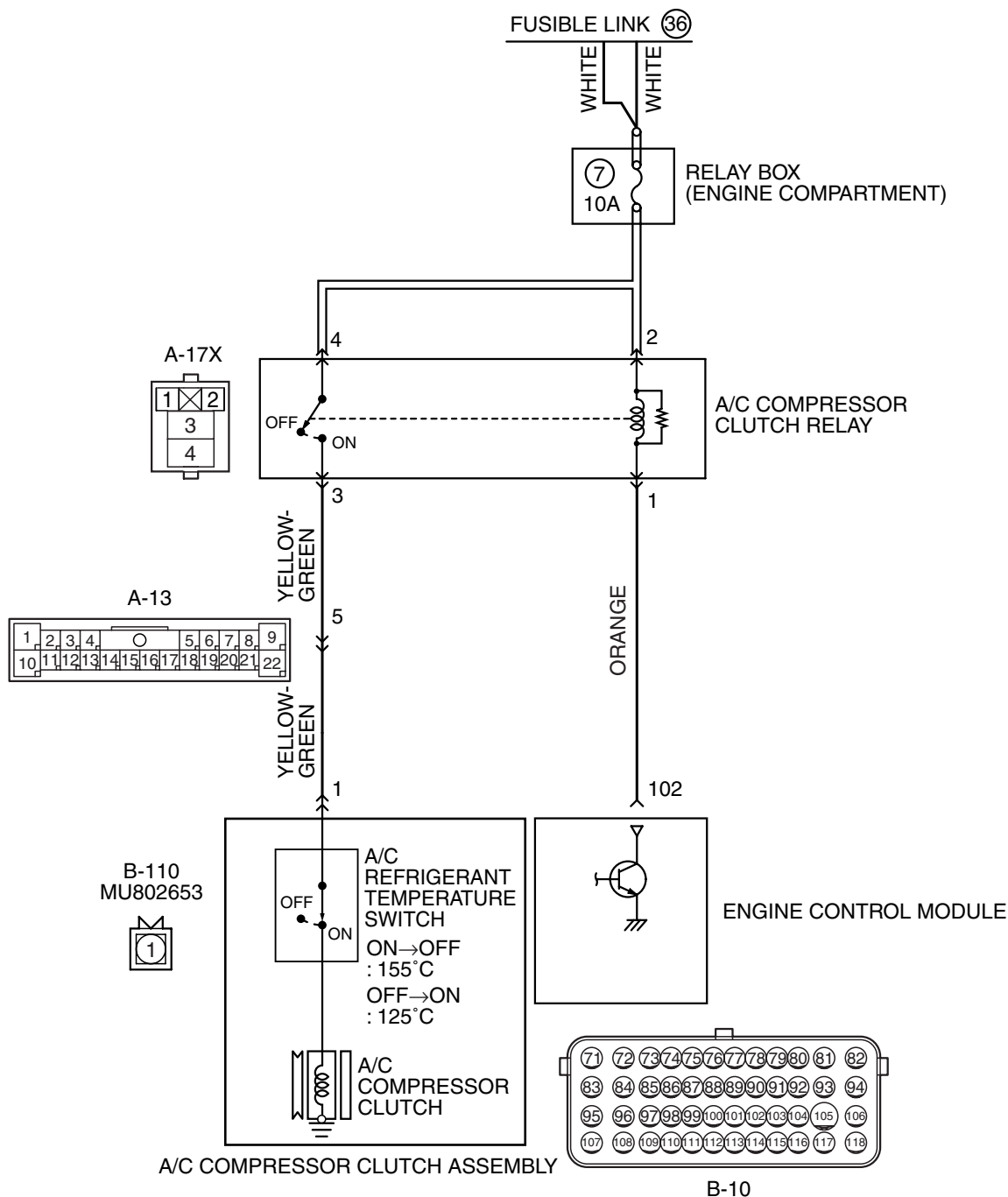

AK704603AB

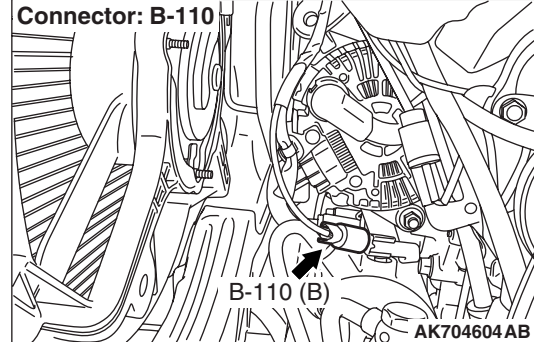
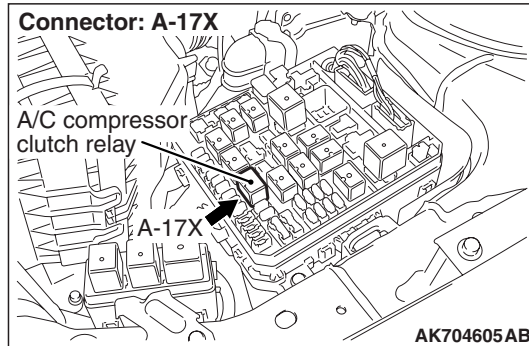
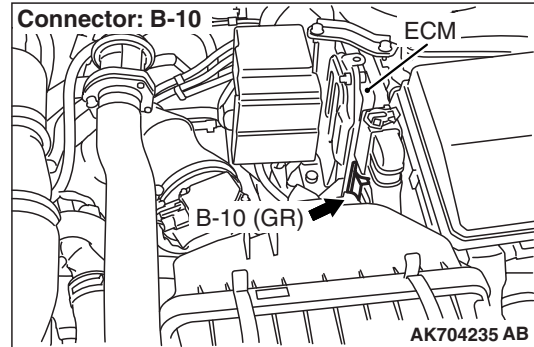
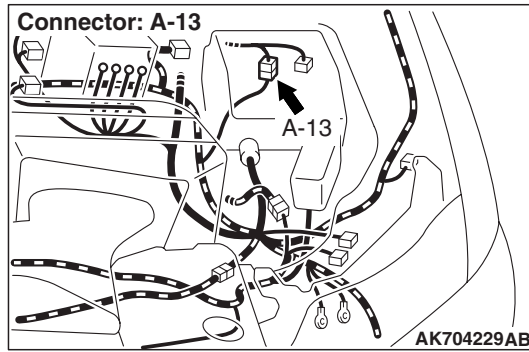

CIRCUIT OPERATION

- When the A/C switch ON signal is input into the ECM, the ECM turns ON the A/C compressor relay. This causes battery positive voltage to be supplied to the A/C compressor and the magnet clutch actuates.

COMMENT

- When the A/C is "ON" the ECM turns "ON" the power transistor in the ECM. The ECM delays A/C engagement momentarily while it increases idle speed. Then the A/C compressor clutch relay coil will be energized.

With this, the A/C compressor clutch relay turns "ON", and the A/C compressor clutch operates.

TROUBLESHOOTING HINTS (The most likely causes for this case:)

- Malfunction of the A/C control system.
- Open or shorted A/C compressor relay circuit, harness damage, or connector damage.
- Malfunction of the ECM.

DIAGNOSIS

STEP 1. Check harness connector B-10 at ECM for damage.

Q: Is the harness connector in good condition?

YES : Go to Step 2.

NO : Repair or replace it. Refer to GROUP 00E, Harness Connector Inspection [P.00E-2](#). Then confirm that the malfunction symptom is eliminated.

STEP 2. Check the circuit at ECM connector B-10.

- (1) Disconnect the connectors B-10 and measure at the harness side.
- (2) Turn the ignition switch to the "ON" position.
- (3) Measure the voltage between terminal No. 102 and ground.
 - Voltage should be battery positive voltage.
- (4) Using a jumper wire, connect terminal No. 102 to ground.
 - A/C compressor clutch relay should turn "ON".
- (5) Turn the ignition switch to the "LOCK" (OFF) position.

Q: Is the voltage and A/C compressor relay condition normal?

YES : Replace the ECM. When the ECM is replaced, register the ID code. Refer to GROUP 42B, Diagnosis –ID Code Registration Judgment Table <Vehicles with KOS> P.42B-12 or GROUP 42C, Diagnosis –ID Codes Registration Judgment Table <Vehicles with WCM> P.42C-9. Then confirm that the malfunction symptom is eliminated.

NO : Refer to GROUP 55, Automatic A/C Diagnosis – Diagnostic Trouble Code Chart P.55-9. Then confirm that the malfunction symptom is eliminated.

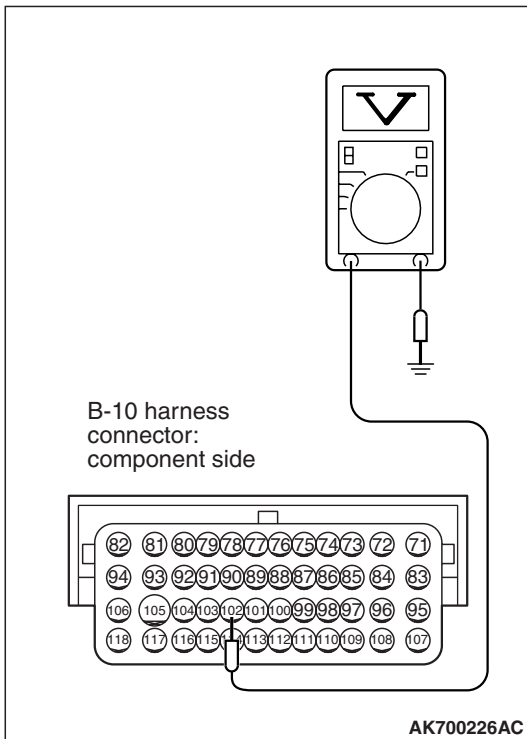

Inspection procedure 28: Engine oil pressure switch system

ENGINE OIL PRESSURE SWITCH CIRCUIT

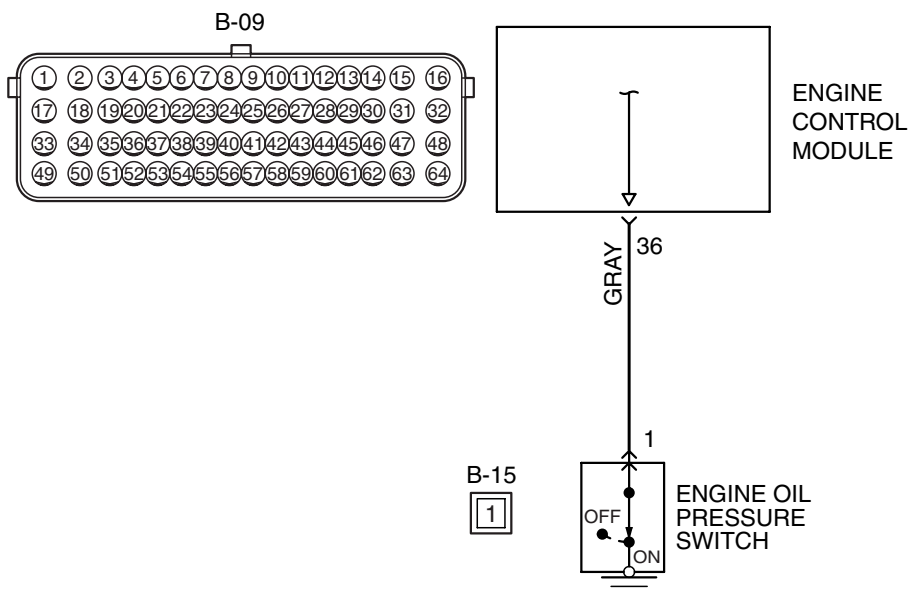

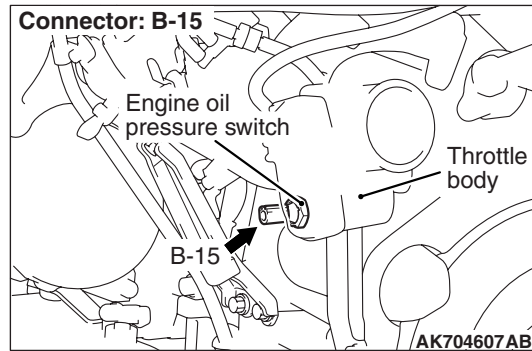
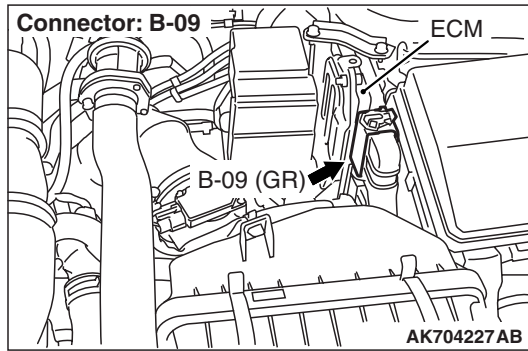

CIRCUIT OPERATION

- Battery voltage is applied to the oil pressure switch (terminal No. 1) from the engine-ECU (terminal No. 36).

COMMENT

- Detect the engine oil pressure conditions and enter the result into the ECM. After starting the engine if the oil pressure rises to higher than the given pressure, the engine oil pressure switch turns OFF. Under this condition the ECM sends the command of turning off the oil warning lamp to the combination meter via CAN.

TROUBLESHOOTING HINTS (The most likely causes for this code to be set are:)

- Engine oil pressure switch failed.
- Open or shorted engine oil pressure switch circuit, harness damage, or connector damage.
- ECM failed.

DIAGNOSIS

Required Special Tools:

- MB991958: Scan Tool (M.U.T.-III Sub Assembly)
 - MB991824: V.C.I.
 - MB991827: USB Cable
 - MB991910: Main Harness A

STEP 1. Check harness connector B-15 at engine oil pressure switch for damage.

Q: Is the harness connector in good condition?

YES : Go to Step 2.

NO : Repair or replace it. Refer to GROUP 00E, Harness Connector Inspection [P.00E-2](#). Then go to Step 5 .

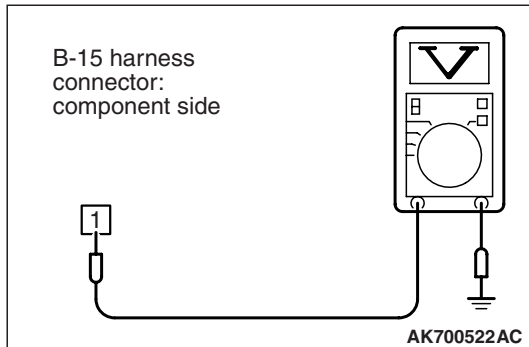

STEP 2. Measure the power supply voltage at engine oil pressure switch connector B-15.

- (1) Disconnect the connector B-15 measure at the harness side.
- (2) Turn the ignition switch to the "ON" position.
- (3) Measure the voltage between terminal No. 1 and ground.
 - The voltage should equal battery positive voltage.
- (4) Turn the ignition switch to the "LOCK" (OFF) position.

Q: Is battery positive voltage (approximately 12 volts) present?

YES : Go to Step 5.

NO : Go to Step 3.

STEP 3. Check harness connector B-09 ECM connector for damage.

Q: Is the connector in good condition?

YES : Go to Step 4.

NO : Repair or replace it. Refer to GROUP 00E, Harness Connector Inspection [P.00E-2](#). Then confirm that the malfunction symptom is eliminated.

STEP 4. Check for open circuit and short circuit to ground between ECM connector B-09 (terminal No. 36) and engine oil pressure switch connector B-15 (terminal No. 1)

Q: Is the harness wire in good condition?

YES : Replace the ECM. When the ECM is replaced, register the ID code. Refer to GROUP 42B, Diagnosis –ID Code Registration Judgment Table <Vehicles with KOS> [P.42B-12](#) or GROUP 42C, Diagnosis –ID Codes Registration Judgment Table <Vehicles with WCM> [P.42C-9](#). Then confirm that the malfunction symptom is eliminated.

NO : Repair it. Then confirm that the malfunction symptom is eliminated.

STEP 5. Check harness connector B-09 ECM connector for damage.

Q: Is the connector in good condition?

YES : Go to Step 6.

NO : Repair or replace it. Refer to GROUP 00E, Harness Connector Inspection [P.00E-2](#). Then confirm that the malfunction symptom is eliminated.

STEP 6. Check for harness damage between ECM connector B-09 (terminal No. 36) and engine oil pressure switch connector B-15 (terminal No. 1)

Q: Is the harness wire in good condition?

YES : Replace the engine oil pressure switch. Then confirm that the malfunction symptom is eliminated.

NO : Repair it. Then confirm that the malfunction symptom is eliminated.

DATA LIST REFERENCE TABLE

M1131152003433

CAUTION

- When shifting the shift lever to D range, the brakes should be applied so that the vehicle does not move forward.
- Driving tests always need two persons: one driver and one observer.

*NOTE: *1: In a new vehicle [driven approximately 500 km (311 mile) or less], the mass airflow sensor output value is sometimes 10% higher than the standard value.*

*NOTE: *2: The injector drive time represents the time when the cranking speed is at 250 r/min or below when the power supply voltage is 11 volts.*

*NOTE: *3: In a new vehicle [driven approximately 500 km (311 mile) or less], the injector drive time is sometimes 10% longer than the standard time.*

*NOTE: *4: Vehicles for Canada, the headlight, taillight, etc. remain lit even when the lighting switch is in "OFF" position but this is no problem for checks.*

*NOTE: *5: Data items are displayed on M.U.T.-III display, but the in-line 4 engine is not applicable and its data is displayed as "N/A".*

M.U.T.-III SCAN TOOL DISPLAY	ITEM NO.	INSPECTION ITEM	INSPECTION REQUIREMENT	NORMAL CONDITION	INSPECTION PROCEDURE NO.	REFERENCE PAGE	
A/C compressor or relay	93	A/C compressor relay	<ul style="list-style-type: none"> • Engine: warming up, idling • A/C switch: "OFF" 	OFF	Procedure No. 27	P.13A-847	
			<ul style="list-style-type: none"> • Engine: warming up, idling • A/C switch: "ON" 	A/C compressor clutch is not operating			OFF
				A/C compressor clutch is operating			ON
A/C SW	76	A/C switch	<ul style="list-style-type: none"> • Engine: warming up, idling • A/C switch: "OFF" 	OFF	Procedure No. 27	P.13A-847	
			<ul style="list-style-type: none"> • Engine: warming up, idling • A/C switch: "ON" 	A/C compressor clutch is not operating			OFF
				A/C compressor clutch is operating			ON
Absolute load value	72	Absolute load value	Engine: warming up	Engine is idling	16 –28 %	–	–
				2,500 r/min	12 –23 %		
				Revvng engine	Load value increases according to amount of revving.		

**MULTIPOINT FUEL INJECTION (MFI)
MULTIPOINT FUEL INJECTION (MFI) DIAGNOSIS**

13A-853

M.U.T.-III SCAN TOOL DISPLAY	ITEM NO.	INSPECTION ITEM	INSPECTION REQUIREMENT		NORMAL CONDITION	INSPECTION PROCEDURE NO.	REFERENCE PAGE
Airflow sensor	10	Mass airflow sensor*1	<ul style="list-style-type: none"> • Engine coolant temperature: 80 – 95° C (176 – 203° F) • Lights, electric cooling fan and all accessories: "OFF"*4 • Transaxle: Neutral (TC-SST: "P" range) 	Engine is idling	1,300 – 1,650 mV	–	–
				2,500 r/min	1,620 – 2,100 mV		
				Engine is revved	Increase in response to revving		
Airflow sensor	AA	Mass airflow sensor*1	<ul style="list-style-type: none"> • Engine coolant temperature: 80 – 95° C (176 – 203° F) • Lights, electric cooling fan and all accessories: "OFF"*4 • Transaxle: Neutral (TC-SST: "P" range) 	Engine is idling	1.8 – 4.4 g/s	–	–
				2,500 r/min	8.0 – 12.0 g/s		
				Engine is revved	Increases in response to revving		
APP sensor (main)	11	Accelerator pedal position sensor (main)	Ignition switch: "ON"	Release the accelerator pedal	900 – 1,100 mV	Code No. P2122, P2123	P.13A-672 , P.13A-677
				Depress the accelerator pedal gradually	Increases in response to the pedal depression stroke		
				Depress the accelerator pedal fully	4,000 mV or more		

M.U.T.-III SCAN TOOL DISPLAY	ITEM NO.	INSPECTION ITEM	INSPECTION REQUIREMENT		NORMAL CONDITION	INSPECTION PROCEDURE NO.	REFERENCE PAGE
APP sensor (main)	BE	Accelerator pedal position sensor (main)	Ignition switch: "ON"	Release the accelerator pedal	18 –22 %	Code No. P2122, P2123	P.13A-672 , P.13A-677
				Depress the accelerator pedal gradually	Increases in response to the pedal depression stroke		
				Depress the accelerator pedal fully	80 % or more		
APP sensor (sub)	12	Accelerator pedal position sensor (sub)	Ignition switch: "ON"	Release the accelerator pedal	400 –600 mV	Code No. P2127, P2128	P.13A-707 , P.13A-709
				Depress the accelerator pedal gradually	Increases in response to the pedal depression stroke		
				Depress the accelerator pedal fully	2,000 mV or more		
APP sensor (sub)	BF	Accelerator pedal position sensor (sub)	Ignition switch: "ON"	Release the accelerator pedal	8 –12 %	Code No. P2127, P2128	P.13A-682 , P.13A-687
				Depress the accelerator pedal gradually	Increases in response to the pedal depression stroke		
				Depress the accelerator pedal fully	40 % or more		
Barometri c pressure sensor	BB	Barometric pressure sensor	Ignition switch: "ON"	Engine stopped [At altitude of 0 m (0 ft.)]	101 kPa (29.8 in.Hg)	Code No. P2228, P2229	P.13A-707 , P.13A-709
				Engine stopped [At altitude of 600 m (1,969 ft.)]	95 kPa (28.1 in.Hg)		
				Engine stopped [At altitude of 1,200 m (3,937 ft.)]	88 kPa (26.0 in.Hg)		
				Engine stopped [At altitude of 1,800 m (5,906 ft.)]	81 kPa (23.9 in.Hg)		

**MULTIPOINT FUEL INJECTION (MFI)
MULTIPOINT FUEL INJECTION (MFI) DIAGNOSIS**

13A-855

M.U.T.-III SCAN TOOL DISPLAY	ITEM NO.	INSPECTION ITEM	INSPECTION REQUIREMENT		NORMAL CONDITION	INSPECTION PROCEDURE NO.	REFERENCE PAGE
Brake light switch	74	Brake light switch	Ignition switch: "ON"	Depress the brake pedal fully	ON	-	-
				Release the brake pedal	OFF		
Calculate d load value	73	Calculated load value	Engine: warming up	Engine is idling	20 –34 %	-	-
				2,500 r/min	6 –13 %		
Closed throttle position switch	84	Closed throttle position signal	Ignition switch: "ON"	Release the accelerator pedal	ON	-	-
				Depress the accelerator pedal fully	OFF		
Cranking signal	79	Cranking signal (ignition switch-ST)	Ignition switch: "ON"	Engine: stopped	OFF	Procedure No. 24 <M/T>, 25 <TC-SST>	P.13A-818 <M/T>, P.13A-830 <TC-SST>
				Engine: cranking	ON		
Crankshaf t position sensor	2	Crankshaft position sensor	<ul style="list-style-type: none"> Engine: cranking Tachometer: connected 		Engine speeds displayed on the scan tool and tachometer are identical.	Code No.P0335	P.13A-367
			Engine: idling	Engine coolant temperature is -20° C (-4° F)	1,300 – 1,500 r/min		
				Engine coolant temperature is 0° C (32° F)	1,300 – 1,500 r/min		
				Engine coolant temperature is 20° C (68° F)	1,300 – 1,500 r/min		
				Engine coolant temperature is 40° C (104° F)	1,200 – 1,400 r/min		
				Engine coolant temperature is 80° C (176° F)	600 –800 r/min		

M.U.T.-III SCAN TOOL DISPLAY	ITEM NO.	INSPECTION ITEM	INSPECTION REQUIREMENT	NORMAL CONDITION	INSPECTION PROCEDURE NO.	REFERENCE PAGE	
ECT sensor	6	Engine coolant temperature sensor	Ignition switch: "ON" or with engine running	Engine coolant temperature is -20° C (-4° F)	-20° C (-4° F)	Code No. P0116, P0117, P0118	P.13A-163 , P.13A-169 , P.13A-174
				Engine coolant temperature is 0° C (32° F)	0° C (32° F)		
				Engine coolant temperature is 20° C (68° F)	20° C (68° F)		
				Engine coolant temperature is 40° C (104° F)	40° C (104° F)		
				Engine coolant temperature is 80° C (176° F)	80° C (176° F)		
Engine control relay	95	MFI relay	Ignition switch: "ON"	ON	-	-	
Engine oil pressure switch	90	Engine oil pressure switch	Ignition switch: "ON"	ON	Procedure No. 28	P.13A-849	
			Engine: idling	OFF			
ETV relay	96	Throttle actuator control motor relay	Ignition switch: "ON"	ON	-	-	
EVAP. emission purge SOL. duty	49	Evaporative emission purge solenoid duty	Engine: warming up with Open loop drive condition, without EVAP leak monitor	1 % or more	-	-	
Exhaust VVT angle (bank 1)	39	Exhaust MIVEC phase angle	Engine: warming up, idle	-3 to 3° CA	Code No. P0014	P.13A-55	
			Engine: warming up, sudden revving	Increase			
Fan duty	47	Fan motor duty	Engine: warming up • The duty ratio of the fan motor driving is shown.	0 -100 % (Display range)	-	-	
Fuel level gauge	51	Fuel level gauge	Ignition switch: "ON" • The residual fuel amount in the tank is shown. • "0 %" means "Empty" and "100 %" means "Full".	0 -100 % (Display range)	-	-	
Fuel pump relay	97	Fuel pump relay	Ignition switch: "ON"	OFF	-	-	
			Engine: cranking	ON			

**MULTIPOINT FUEL INJECTION (MFI)
MULTIPOINT FUEL INJECTION (MFI) DIAGNOSIS**

13A-857

M.U.T.-III SCAN TOOL DISPLAY	ITEM NO.	INSPECTION ITEM	INSPECTION REQUIREMENT		NORMAL CONDITION	INSPECTION PROCEDURE NO.	REFERENCE PAGE
Fuel system status (bank 1)	105	Fuel control system status	Engine: warming up	2,500 r/min	CL: Using O2S	-	-
				When engine is suddenly revved	OL: DRV condition		
Fuel system status (bank 2) ^{*5}	106	Fuel control system status (bank 2)	-		-	-	-
Fuel tank differential PRS. SNSR	52	Fuel tank differential pressure sensor	<ul style="list-style-type: none"> Ignition switch: "ON" Fuel cap removal 		1,500 – 3,500 mV	-	-
Fuel tank temperatu re sensor	53	Fuel tank temperature sensor	<ul style="list-style-type: none"> In cooled state Ignition switch: "ON" 		Approximate ly the same as the outdoor temperature	Code No. P0181, P0182, P0183	P.13A-258 , P.13A-265 , P.13A-270
Ignition switch	85	Ignition switch (IG1)	Ignition switch: "ON"		ON	-	-
Injectors	17	Injectors ^{*2}	Engine: cranking	When engine coolant temperature is 0° C (32° F)	16 –36 ms	-	-
				When engine coolant temperature is 20° C (68° F)	8 –20 ms		
				When engine coolant temperature is 80° C (176° F)	2 –6 ms		
		Injectors ^{*3}	<ul style="list-style-type: none"> Engine coolant temperatur e: 80 – 95° C (176 – 203° F) Lights, electric cooling fan and all accessorie s: "OFF" Transaxle: Neutral (TC-SST: "P" range) 	Engine is idling	1.3 –3.3 ms		
				2,500 r/min	1.0 –3.2 ms		
				When engine is suddenly revved	Increases		

M.U.T.-III SCAN TOOL DISPLAY	ITEM NO.	INSPECTION ITEM	INSPECTION REQUIREMENT	NORMAL CONDITION	INSPECTION PROCEDURE NO.	REFERENCE PAGE	
Intake air temperatu re sensor	5	Intake air temperature sensor	Ignition switch: "ON" or with engine running	Intake air temperature is -20° C (-4° F)	-20° C (-4° F)	Code No. P0111, P0112, P0113	P.13A-147 , P.13A-153 , P.13A-157
				Intake air temperature is 0° C (32° F)	0° C (32° F)		
				Intake air temperature is 20° C (68° F)	20° C (68° F)		
				Intake air temperature is 40° C (104° F)	40° C (104° F)		
				Intake air temperature is 80° C (176° F)	80° C (176° F)		
Intake VVT angle (bank 1)	36	Intake MIVEC phase angle	Engine: warming up, idle	-13 to 7° CA	Code No. P0011	P.13A-51	
			Engine: warming up, sudden revving	Decreased			
ISC learned value (A/C OFF)	68	Idle speed control learned value (A/C OFF)	Ignition switch: "ON" <ul style="list-style-type: none"> Indicates the leaning value to compensate for the opening angle of idling speed control (opening angle of throttle valve). The negative side shows "close" side, while the positive side shows "open" side. 	-1 to 2.0 L/s (Display range)	-	-	
ISC learned value (A/C ON)	69	Idle speed control learned value (A/C ON)	Ignition switch: "ON" <ul style="list-style-type: none"> Indicates the leaning value to compensate for the opening angle of idling speed control (opening angle of throttle valve) with the air conditioner turned ON. The negative side shows "close" side, while the positive side shows "open" side. 	-1 to 2.0 L/s (Display range)	-	-	
Knock retard	32	Knock retard	Engine: warming up, sudden racing	According to acceleration, knock retard is increased.	-	-	

**MULTIPOINT FUEL INJECTION (MFI)
MULTIPOINT FUEL INJECTION (MFI) DIAGNOSIS**

13A-859

M.U.T.-III SCAN TOOL DISPLAY	ITEM NO.	INSPECTION ITEM	INSPECTION REQUIREMENT		NORMAL CONDITION	INSPECTION PROCEDURE NO.	REFERENCE PAGE
Learned knock retard	33	Knock control learned value	Ignition switch: "ON" <ul style="list-style-type: none"> The learning value is shown, which compensates the ignition time based on the knock sensor. "0 %" means "retard angle" and "100 %" means "advance angle". 		0 –100 % (Display range)	–	–
Long term fuel trim (bank 1)	26	Long-term fuel trim	Engine: warming up, 2,500 r/min without any load (during closed loop)		–12.5 to 12.5 %	Code No. P0171, P0172	P.13A-246 , P.13A-252
MAP sensor	8	Manifold absolute pressure sensor	Ignition switch: "ON"	Engine stopped [At altitude of 0 m (0 ft.)]	101 kPa (29.8 in.Hg)	Code No. P0106, P0107, P0108	P.13A-125 , P.13A-134 , P.13A-142
				Engine stopped [At altitude of 600 m (1,969 ft.)]	95 kPa (28.1 in.Hg)		
				Engine stopped [At altitude of 1,200 m (3,937 ft.)]	88 kPa (26.0 in.Hg)		
				Engine stopped [At altitude of 1,800 m (5,906 ft.)]	81 kPa (23.9 in.Hg)		
			Engine: warming up, idling		31 –45 kPa (9.1 –13.3 in.Hg)		
			When engine is suddenly revved		Manifold pressure varies		
Neutral switch	87	Neutral switch <TC-SST>	Ignition switch: "ON"	Engine stopped	ON	–	–
				<ul style="list-style-type: none"> Except engine stopped Shift lever: "P" or "N" range 	ON		
				<ul style="list-style-type: none"> Except engine stopped Shift lever: "R" or "D" range 	OFF		
Normally closed brake switch	89	Normally closed brake switch	Ignition switch: "ON"	Depress the brake pedal	ON	–	–
				Release the brake pedal	OFF		

M.U.T.-III SCAN TOOL DISPLAY	ITEM NO.	INSPECTION ITEM	INSPECTION REQUIREMENT		NORMAL CONDITION	INSPECTION PROCEDURE NO.	REFERENCE PAGE
Oxygen sensor (bank 1 sensor 1)	AC	Heated oxygen sensor (front)	Engine: warming up (Air/fuel mixture is made leaner when decelerating and is made richer when revving)	When the engine is running at 4,000 r/min, decelerate suddenly.	0.2 V or less →0.6 –1.0 V (After several seconds have elapsed)	Code No. P0131, P0132, P0133, P0134, P2195	P.13A-203 , P.13A-211 , P.13A-215 , P.13A-220 , P.13A-704
				When engine is suddenly raced	0.6 –1.0 V		
			Engine: warming up (the heated oxygen sensor signal is used to check the air/fuel mixture ratio, and control condition is also checked by the ECM.)	Engine is idling 2,500 r/min	Voltage changes repeatedly between 0.4 V or less and 0.6 –1.0 V.		
Oxygen sensor (bank 1 sensor 2)	AD	Heated oxygen sensor (rear)	<ul style="list-style-type: none"> • Transaxle: 2 nd • Drive with wide open throttle • Engine: 3,500 r/min or more 		0.6 –1.0 V	Code No. P0137, P0138, P0139, P0140	P.13A-226 , P.13A-234 , P.13A-238 , P.13A-242
Power steering switch	83	Power steering pressure switch	Engine: idling	Steering wheel stationary	OFF	Code No.P0551	P.13A-553
				Steering wheel turning	ON		
Power supply voltage	1	Power supply voltage	Ignition switch: "ON"		Battery positive voltage	Procedure No. 22	P.13A-794

**MULTIPOINT FUEL INJECTION (MFI)
MULTIPOINT FUEL INJECTION (MFI) DIAGNOSIS**

13A-861

M.U.T.-III SCAN TOOL DISPLAY	ITEM NO.	INSPECTION ITEM	INSPECTION REQUIREMENT		NORMAL CONDITION	INSPECTION PROCEDURE NO.	REFERENCE PAGE
Relative TP sensor	BC	Relative throttle position sensor	<ul style="list-style-type: none"> Remove the intake air hose at the throttle body Disconnect the throttle position sensor connector, and then connect terminal numbers No. 3, No. 4, No. 5 and No. 6 with the use of the special tool: MB991658. Ignition switch: "ON" 	Fully close the throttle valve with your finger	0 -5 %	-	-
				Fully open the throttle valve with your finger	88 % or more		
Short term fuel trim (bank 1)	28	Short-term fuel trim	Engine: warming up, 2,500 r/min without any load (during closed loop)		-25 to 25 %	Code No. P0171, P0172	P.13A-246 , P.13A-252
Spark advance	16	Ignition timing advance	<ul style="list-style-type: none"> Engine: warming up Timing light is set (to check actual ignition timing) Transaxle: neutral (TC-SST: "P" range) 	Engine is idling	2 -18° CA (BTDC)	-	-
				2,500 r/min	34 -46° CA (BTDC)		
Starter relay	102	Starter relay	Ignition switch: "ON"		OFF	Procedure No. 24 <M/T>, 25 <TC-SST>	P.13A-818 <M/T>, P.13A-830 <TC-SST>
			Engine: Cranking		ON		

M.U.T.-III SCAN TOOL DISPLAY	ITEM NO.	INSPECTION ITEM	INSPECTION REQUIREMENT	NORMAL CONDITION	INSPECTION PROCEDURE NO.	REFERENCE PAGE										
Target ETV value	59	Throttle actuator control motor target value	Engine: warming up <ul style="list-style-type: none"> The target opening degree of the throttle valve is shown. "0 V" means "fully closed throttle valve" and "5 V" means "fully opened throttle valve". 	0 –5 V (Display range)	–	–										
Target idle speed	3	Target idle speed	Engine: idling	<table border="1"> <tr> <td>Engine coolant temperature is -20° C (-4° F)</td> <td>1,300 – 1,500 r/min</td> </tr> <tr> <td>Engine coolant temperature is 0° C (32° F)</td> <td>1,300 – 1,500 r/min</td> </tr> <tr> <td>Engine coolant temperature is 20° C (68° F)</td> <td>1,300 – 1,500 r/min</td> </tr> <tr> <td>Engine coolant temperature is 40° C (104° F)</td> <td>1,200 – 1,400 r/min</td> </tr> <tr> <td>Engine coolant temperature is 80° C (176° F)</td> <td>600 –800 r/min</td> </tr> </table>	Engine coolant temperature is -20° C (-4° F)	1,300 – 1,500 r/min	Engine coolant temperature is 0° C (32° F)	1,300 – 1,500 r/min	Engine coolant temperature is 20° C (68° F)	1,300 – 1,500 r/min	Engine coolant temperature is 40° C (104° F)	1,200 – 1,400 r/min	Engine coolant temperature is 80° C (176° F)	600 –800 r/min	–	–
Engine coolant temperature is -20° C (-4° F)	1,300 – 1,500 r/min															
Engine coolant temperature is 0° C (32° F)	1,300 – 1,500 r/min															
Engine coolant temperature is 20° C (68° F)	1,300 – 1,500 r/min															
Engine coolant temperature is 40° C (104° F)	1,200 – 1,400 r/min															
Engine coolant temperature is 80° C (176° F)	600 –800 r/min															
Throttle actuator	58	Throttle actuator control motor	Engine: warming up <ul style="list-style-type: none"> The target opening degree of the throttle valve is shown. "0 %" means "fully closed throttle valve" and "100 %" means "fully opened throttle valve". 	0 –100 % (Display range)	–	–										

**MULTIPOINT FUEL INJECTION (MFI)
MULTIPOINT FUEL INJECTION (MFI) DIAGNOSIS**

13A-863

M.U.T.-III SCAN TOOL DISPLAY	ITEM NO.	INSPECTION ITEM	INSPECTION REQUIREMENT	NORMAL CONDITION	INSPECTION PROCEDURE NO.	REFERENCE PAGE				
TP sensor (main)	AB	Throttle position sensor (main)	<ul style="list-style-type: none"> • Remove the intake air hose at the throttle body • Disconnect the throttle position sensor connector, and then connect terminal numbers No. 3, No. 4, No. 5 and No. 6 with the use of the special tool: MB991658. • Ignition switch: "ON" 	<table border="1" style="width: 100%; border-collapse: collapse;"> <tr> <td style="width: 50%; padding: 2px;">Fully close the throttle valve with your finger</td> <td style="width: 50%; padding: 2px;">6 –14 %</td> </tr> <tr> <td style="width: 50%; padding: 2px;">Fully open the throttle valve with your finger</td> <td style="width: 50%; padding: 2px;">80 % or more</td> </tr> </table>	Fully close the throttle valve with your finger	6 –14 %	Fully open the throttle valve with your finger	80 % or more	Code No. P0122, P0123	P.13A-181 , P.13A-185
Fully close the throttle valve with your finger	6 –14 %									
Fully open the throttle valve with your finger	80 % or more									

M.U.T.-III SCAN TOOL DISPLAY	ITEM NO.	INSPECTION ITEM	INSPECTION REQUIREMENT	NORMAL CONDITION	INSPECTION PROCEDURE NO.	REFERENCE PAGE		
TP sensor (main)	13	Throttle position sensor (main)	<ul style="list-style-type: none"> • Remove the intake air hose at the throttle body • Disconnect the throttle position sensor connector, and then connect terminal numbers No. 3, No. 4, No. 5 and No. 6 with the use of the special tool: MB991658. • Ignition switch: "ON" 	Fully close the throttle valve with your finger	300 –700 mV	Code No. P0122, P0123	P.13A-181, P.13A-185	
				Fully open the throttle valve with your finger	4,000 mV or more			
				Engine: warming up, idling	No load			500 –660 mV
					A/C switch: "OFF" → "ON"			Voltage varies
	Shift lever: "N" → "D" range <TC-SST>							
TP sensor (main) learned value	14	Throttle position sensor (main) mid opening learning value	This item shows the throttle valve opening learning value when the vehicle enters into the limp home mode.		–	–		

**MULTIPOINT FUEL INJECTION (MFI)
MULTIPOINT FUEL INJECTION (MFI) DIAGNOSIS**

13A-865

M.U.T.-III SCAN TOOL DISPLAY	ITEM NO.	INSPECTION ITEM	INSPECTION REQUIREMENT	NORMAL CONDITION	INSPECTION PROCEDURE NO.	REFERENCE PAGE	
TP sensor (sub)	BD	Throttle position sensor (sub)	<ul style="list-style-type: none"> • Remove the intake air hose at the throttle body • Disconnect the throttle position sensor connector, and then connect terminal numbers No. 3, No. 4, No. 5 and No. 6 with the use of the special tool: MB991658. • Ignition switch: "ON" 	Fully close the throttle valve with your finger	6 –14 %	Code No. P0222, P0223	P.13A-317 , P.13A-323
				Fully open the throttle valve with your finger	80 % or more		
TP sensor (sub)	15	Throttle position sensor (sub)	<ul style="list-style-type: none"> • Remove the intake air hose at the throttle body • Disconnect the throttle position sensor connector, and then connect terminal numbers No. 3, No. 4, No. 5 and No. 6 with the use of the special tool: MB991658. • Ignition switch: "ON" 	Fully close the throttle valve with your finger	4,000 mV or more	Code No. P0222, P0223	P.13A-317 , P.13A-323
				Fully open the throttle valve with your finger	1,000 mV or less		

M.U.T.-III SCAN TOOL DISPLAY	ITEM NO.	INSPECTION ITEM	INSPECTION REQUIREMENT	NORMAL CONDITION	INSPECTION PROCEDURE NO.	REFERENCE PAGE
Vehicle speed	4	Vehicle speed	Drive at 40 km/h (25 mph).	Approximately 40 km/h (25 mph)	—	—
Wastegate duty	48	Turbocharger wastegate solenoid 1 duty	Engine: warming up	0 –100 % (Display range)	Code No. P0243	P.13A-330
Wastegate duty (bank 2)	116	Turbocharger wastegate solenoid 2 duty	Engine: warming up	0 –100 % (Display range)	Code No. P0247	P.13A-337

GENERAL SCAN TOOL (GST) MODE 01 REFERENCE TABLE

M1131156000191

The purpose of this service of to allow access to current emission-related data values, including analogue inputs and outputs, digital inputs and outputs, and system status information.

The request for information includes a parameter identification (PID) value that indicates to the on-board system the specific information requested.

The ECM will respond to this message by transmitting the requested data value last determined by the system. All data values returned for sensor readings will be actual readings, not default or substitute values used by the system because of a fault with that sensor.

NOTE: GST MODE 01 can be accessed through the use of a general scan tool.

PARAMETER IDENTIFICATION (PID)	DESCRIPTION	COMMON EXAMPLE OF GENERAL SCAN TOOL DISPLAY	INSPECTION CONDITION	NORMAL CONDITION
01	Number of emission-related DTCs and MIL status	DTC and MIL status:	—	
	Number of DTCs stored in this ECU	DTC_CNT: xxxd		
	Malfunction Indicator Lamp (MIL) status	MIL: OFF or ON		
	Supported tests which are continuous	Support status of continuous monitors:		
	Misfire monitoring	MIS_SUP: YES		
	Fuel system monitoring	FUEL_SUP: YES		
	Comprehensive component monitoring	CCM_SUP: YES		
	Status of continuous monitoring tests since DTC cleared	Completion status of continuous monitors since DTC cleared:		
	Misfire monitoring	MIS_RDY: YES or NO		
	Fuel system monitoring	FUEL_RDY: YES or NO		

**MULTIPOINT FUEL INJECTION (MFI)
MULTIPOINT FUEL INJECTION (MFI) DIAGNOSIS**

13A-867

PARAMETER IDENTIFICATION (PID)	DESCRIPTION	COMMON EXAMPLE OF GENERAL SCAN TOOL DISPLAY	INSPECTION CONDITION	NORMAL CONDITION
01	Comprehensive component monitoring	CCM_RDY: YES or NO	-	
	Supported tests run at least once per trip	Support status of non-continuous monitors:		
	Catalyst monitoring	CAT_SUP: YES		
	Heated catalyst monitoring	HCAT_SUP: NO		
	Evaporative system monitoring	EVAP_SUP: YES		
	Secondary air system monitoring	AIR_SUP: NO		
	A/C system refrigerant monitoring	ACRF_SUP: NO		
	Oxygen sensor monitoring	O2S_SUP: YES		
	Oxygen sensor heater monitoring	HTR_SUP: YES		
	EGR system monitoring	EGR_SUP: YES		
	Status of tests run at least once per trip	Completion status of non-continuous monitors since DTC cleared:		
	Catalyst monitoring	CAT_RDY: YES or NO		
	Heated catalyst monitoring	HCAT_RDY: YES		
	Evaporative system monitoring	EVAP_RDY: YES or NO		
	Secondary air system monitoring	AIR_RDY: YES		
	A/C system refrigerant monitoring	ACRF_RDY: YES		
	Oxygen sensor monitoring	O2S_RDY: YES or NO		
	Oxygen sensor heater monitoring	HTR_RDY: YES or NO		
	EGR system monitoring	EGR_RDY: YES or NO		
	03	Fuel system 1 status		
04	Calculated LOAD Value	LOAD_PCT: xxx.x%	See M.U.T.-III item No. 73.	
05	Engine Coolant Temperature	ECT: xxx° C (xxx° F)	See M.U.T.-III item No. 6.	
06	Short Term Fuel Trim-Bank 1	SHRTFT1: xxx.x%	See M.U.T.-III item No. 28.	
07	Long Term Fuel Trim-Bank 1	LONGFT1: xxx.x%	See M.U.T.-III item No. 26.	
0B	Intake Manifold Absolute Pressure	MAP: xxx kPa (xx.x inHg)	See M.U.T.-III item No. 8.	
0C	Engine RPM	RPM: xxxxx min ⁻¹	See M.U.T.-III item No. 2.	
0D	Vehicle Speed Sensor	VSS: xxx km/h (xxx mph)	See M.U.T.-III item No. 4.	

PARAMETER IDENTIFICATION (PID)	DESCRIPTION	COMMON EXAMPLE OF GENERAL SCAN TOOL DISPLAY	INSPECTION CONDITION	NORMAL CONDITION
0E	Ignition Timing Advance for #1 Cylinder	SPARKADV: xx°	See M.U.T.-III item No. 16.	
0F	Intake Air Temperature	IAT: xxx° C (xxx° F)	See M.U.T.-III item No. 5.	
10	Air Flow Rate from Mass Air Flow Sensor	MAF: xxx.xx g/s (xxxx.x lb/min)	See M.U.T.-III item No. AA.	
11	Absolute Throttle Position	TP: xxx.x%	See M.U.T.-III item No. AB.	
13	Location of Oxygen Sensor	O2SLOC: OxSxx	<ul style="list-style-type: none"> Ignition switch: "ON" 	O2S11/O2S12/O2S13/O2S21/O2S22
14	Bank 1 –Sensor 1	O2S11: x.xxx V	See M.U.T.-III item No. AC.	
		SHRTFT11: xxx.x%	Engine: warming up, 2,500 r/min without any load (during closed loop)	-25 to 25%
15	Bank 1 –Sensor 2	O2S12: x.xxx V	See M.U.T.-III item No. AD.	
1C	OBD requirements to which vehicle is designed	OBDSUP: OBD II	Ignition switch: "ON"	OBD II
1F	Time Since Engine Start	RUNTM: xxxxx sec.	–	
21	Distance Travelled While MIL is Active	MIL DIST: xxxxx km (xxxxx miles)	–	
2E	Commanded Evaporative Purge	EVAP_PCT: xxx.x%	See M.U.T.-III item No. 49.	
2F	Fuel Level Input	FLI: xxx.x%	See M.U.T.-III item No. 51.	
30	Number of warm-ups since diagnostic trouble codes cleared	WARM_UPS: xxx	–	
31	Distance since diagnostic trouble codes cleared	CLR_DIST: xxxxx km (xxxxx miles)	–	
32	Evap System Vapor Pressure	EVAP_VP: xxxx.xx Pa (xx.xxx in H2O)	<ul style="list-style-type: none"> Ignition switch: "ON" Fuel cap removal 	-3.3 to 3.3 kPa (-13.4 to 13.4 in.H2O)
33	Barometric Pressure	BARO: xxx kPa (xx.x inHg)	See M.U.T.-III item No. BB.	
41	Monitor status this driving cycle	–		

**MULTIPOINT FUEL INJECTION (MFI)
MULTIPOINT FUEL INJECTION (MFI) DIAGNOSIS**

13A-869

PARAMETER IDENTIFICATION (PID)	DESCRIPTION	COMMON EXAMPLE OF GENERAL SCAN TOOL DISPLAY	INSPECTION CONDITION	NORMAL CONDITION
	Enable status of continuous monitors this monitoring cycle:	Enable status of continuous monitors this monitoring cycle: NO means disable for rest of this monitoring cycle or not supported in PID 01, YES means enable for this monitoring cycle.		
	Misfire monitoring	MIS_ENA: NO or YES		
	Fuel system monitoring	FUEL_ENA: NO or YES		
	Comprehensive component monitoring	CCM_ENA: YES		
	Completion status of continuous monitors this monitoring cycle:	Completion status of continuous monitors this monitoring cycle:		
	Misfire monitoring	MIS_CMPL: YES or NO		
	Fuel system monitoring	FUEL_CMPL: YES or NO		
	Comprehensive component monitoring	CCM_CMPL: YES or NO		
	Enable status of non-continuous monitors this monitoring cycle:	Enable status of non-continuous monitors this monitoring cycle:		
	Catalyst monitoring	CAT_ENA: YES or NO		
	Heated catalyst monitoring	HCAT_ENA: NO		
	Evaporative system monitoring	EVAP_ENA: YES or NO		
	Secondary air system monitoring	AIR_ENA: YES or NO		
	A/C system refrigerant monitoring	ACRF_ENA: YES or NO		
	Oxygen sensor monitoring	O2S_ENA: YES or NO		
	Oxygen sensor heater monitoring	HTR_ENA: YES or NO		
	EGR system monitoring	EGR_ENA: YES or NO		
	Completion status of non-continuous monitors this monitoring cycle:	Completion status of non-continuous monitors this monitoring cycle:		
	Catalyst monitoring	CAT_CMPL: YES or NO		
	Evaporative system monitoring	EVAP_CMPL: YES or NO		
	Oxygen sensor monitoring	O2S_CMPL: YES or NO		
41	Oxygen sensor heater monitoring	HTR_CMPL: YES or NO	-	

PARAMETER IDENTIFICATION (PID)	DESCRIPTION	COMMON EXAMPLE OF GENERAL SCAN TOOL DISPLAY	INSPECTION CONDITION	NORMAL CONDITION
	EGR system monitoring	EGR_CMPL: YES or NO		
42	Control module voltage	VPWR: xx.xxx V	See M.U.T.-III item No. 1.	
43	Absolute Load Value	LOAD_ABS: xxx.x%	See M.U.T.-III item No. 72.	
44	Commanded Equivalence Ratio	EQ_RAT: x.xxx	Engine: running <ul style="list-style-type: none"> • "1" means "stoichiometric air fuel ratio". The smaller air fuel ratio, the rich return. The more air fuel ratio, the lean return. 	0 –1.999 (Display range)
45	Relative Throttle Position	TP_R: xxx.x%	See M.U.T.-III item No. BC.	
46	Ambient air temperature	AAT: xxx° C (xxx° F)	<ul style="list-style-type: none"> • Ignition switch: "ON" • Engine is cold state 	The value displayed approximately matches the ambient temperature
47	Absolute Throttle Position B	TP_B: xxx.x%	See M.U.T.-III item No. BD.	
49	Accelerator Pedal Position D	APP_D: xxx.x%	See M.U.T.-III item No. BE.	
4A	Accelerator Pedal Position E	APP_E: xxx.x%	See M.U.T.-III item No. BF.	
4C	Commanded Throttle Actuator Control	TAC_PCT: xxx.x%	See M.U.T.-III item No. 58.	
68	Intake Air Temperature	IAT: xxx° C (xxx° F) IAT2: xxx° C (xxx° F)	<ul style="list-style-type: none"> • Ignition switch: "ON" • Engine is cold state 	The value displayed approximately matches the ambient temperature

ACTUATOR TEST REFERENCE TABLE

M1131152502275

*NOTE: *: Continues for 27 minutes. Can be released by pressing the CLEAR key.*

M.U.T.-III SCAN TOOL DISPLAY	ITEM NO.	INSPECTION ITEM	DRIVE CONTENTS	INSPECTION REQUIREMENT		NORMAL CONDITION	INSPECTION PROCEDURE NO.	REFERENCE PAGE
A/C relay	16	A/C compressor clutch relay	A/C compressor clutch relay turns from OFF to ON.	Ignition switch: "ON"		Clicks when A/C compressor clutch is driven.	Procedure No. 27	P.13A-847
Cooling fan	14	Radiator fan, A/C condenser fan	Drive the fan motor	Ignition switch: "ON"		Radiator fan and A/C condenser fan rotate.	—	—
EVAP. emission purge SOL. valve	10	Evaporative emission purge solenoid	Solenoid valve turns from OFF to ON.	Ignition switch: "ON"		Clicks when solenoid valve is driven.	Code No. P0443	P.13A-412
EVAP. emission ventilation SOL.	15	Evaporative emission ventilation solenoid	Solenoid valve turns from OFF to ON.	Ignition switch: "ON"		Clicks when solenoid valve is driven.	Code No. P0446	P.13A-419
Fuel pump	9	Fuel pump	Fuel pump operates and fuel is recirculated	Ignition switch: "ON"	Listen near the fuel tank for the sound of fuel pump operation	Sound of operation is heard	Procedure No. 23	P.13A-805
Ignition timing 5 BTDC	11*	Basic ignition timing	Set to ignition timing adjustment mode	<ul style="list-style-type: none"> • Engine: idling • Connect timing light 		5° BTDC	—	—

M.U.T.-III SCAN TOOL DISPLAY	ITEM NO.	INSPECTION ITEM	DRIVE CONTENTS	INSPECTION REQUIREMENT	NORMAL CONDITION	INSPECTION PROCEDURE NO.	REFERENCE PAGE
Injector stop	1	Injectors	Specified injector is stopped	Engine: warm up, idle (cut the fuel supply to each injector in turn and check cylinders which don't affect idling.)	Idle condition is changed by stopping selected cylinder: this can cause an unstable condition and the engine may stall.	Code No. P0201, Code No. P0202, Code No. P0203, Code No. P0204	P.13A-277 , P.13A-287 , P.13A-297 , P.13A-307
Oil control valve	17	Intake engine oil control valve, exhaust engine oil control valve	Switch the intake engine oil control valve and exhaust engine control valve from OFF to ON	Ignition switch: "ON"	When the valve is actuated, operating noise is audible.	Code No. P1021, P1025	P.13A-594 , P.13A-601
Wastegate solenoid valve	20	Turbocharger wastegate solenoid 1, turbocharger wastegate solenoid 2	Solenoid valve turns from OFF to ON.	Ignition switch: "ON"	Clicks when solenoid valve is driven.	Code No. P0243, P0247	P.13A-330 , P.13A-337

CHECK AT THE ENGINE CONTROL MODULE (ECM)

M1131153501435

1. Disconnect the ECM connectors B-09 and B-10, and connect check harness special tool MB992110 between the ECM connectors.
2. Measure the voltage between each check harness connector terminal and check harness connector ground terminal (No. 81 or No. 93).

TERMINAL VOLTAGE CHECK CHART

*NOTE: *1: The average voltage through an analog voltmeter is described in this service manual (because the average voltage would be not constantly shown on a digital voltmeter).*

*NOTE: *2: Vehicles for Canada, the headlight, taillight, etc. remain lit even when the lighting switch is in "OFF" position but is no problem for checks.*

Check harness special tool MB992110 connector terminal arrangement

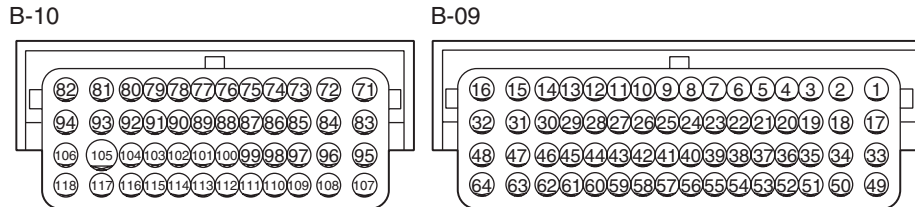

AK604559 AD

TERMINAL NO.	INSPECTION ITEM	INSPECTION CONDITION (ENGINE CONDITION)	NORMAL CONDITION
1	Intake engine oil control valve	Ignition switch: "ON"	B+
		Engine: Warming up, under the high load operation.	4 –10 V*1
2	No. 1 injector	Engine: While engine is idling after having warmed up, suddenly depress the accelerator pedal.	From 9 –15 V*1, it is slightly reduced temporarily.
3	No. 2 injector		
18	No. 3 injector		
19	No. 4 injector		
4	Ignition coil No. 1 (ignition power transistor)	Engine: 3,000 r/min	0.1 –2.0 V*1
5	Ignition coil No. 2 (ignition power transistor)		
20	Ignition coil No. 3 (ignition power transistor)		
21	Ignition coil No. 4 (ignition power transistor)		
6	Starter active signal	Engine: cranking	B+
		Engine: idling	1 V or less
7	Exhaust camshaft position sensor	Engine: cranking	2.0 –4.8 V*1
		Engine: idling	2.0 –3.0 V*1
8	Crankshaft position sensor	Engine: cranking	0.4 –4.0 V*1
		Engine: idling	2.0 –3.0 V*1
9	Sensor supplied voltage	Ignition switch: "ON"	4.9 –5.1 V

TERMINAL NO.	INSPECTION ITEM	INSPECTION CONDITION (ENGINE CONDITION)	NORMAL CONDITION	
10	Throttle position sensor (main)	<ul style="list-style-type: none"> • Remove the intake air hose at the throttle body • Disconnect the throttle position sensor connector, and then connect terminal numbers No. 3, No. 4, No. 5 and No. 6 with the use of the special tool: MB991658. • Ignition switch: "ON" 	Fully close the throttle valve with your finger	0.3 –0.7 V
			Fully open the throttle valve with your finger	4.0 V or more
11	Throttle position sensor (sub)	<ul style="list-style-type: none"> • Remove the intake air hose at the throttle body • Disconnect the throttle position sensor connector, and then connect terminal numbers No. 3, No. 4, No. 5 and No. 6 with the use of the special tool: MB991658. • Ignition switch: "ON" 	Fully close the throttle valve with your finger	4.0 V or more
			Fully open the throttle valve with your finger	1.0 V or less
12	Power supply voltage applied to throttle position sensor	Ignition switch: "ON"	4.9 –5.1 V	
14	Intake camshaft position sensor	Engine: cranking	2.0 –4.8 V*1	
		Engine: idling	2.0 –3.0 V*1	
15	Throttle actuator control motor (+)	<ul style="list-style-type: none"> • Ignition switch: "ON" • Accelerator pedal: fully opened →fully closed 	Decreases slightly (Approximately 2 V) from battery voltage.	

TERMINAL NO.	INSPECTION ITEM	INSPECTION CONDITION (ENGINE CONDITION)	NORMAL CONDITION	
16	Throttle actuator control motor (-)	<ul style="list-style-type: none"> Ignition switch: "ON" Accelerator pedal: fully closed →fully opened 	Decreases slightly (Approximately 2 V) from battery voltage.	
17	Exhaust engine oil control valve	Ignition switch: "ON"	B+	
		Engine: Warming up, under the high load operation.	4.0 –10 V* ¹	
26	Engine coolant temperature sensor	Ignition switch: "ON"	When engine coolant temperature is -20° C (-4° F)	3.9 –4.5 V
			When engine coolant temperature is 0° C (32° F)	3.2 –3.8 V
			When engine coolant temperature is 20° C (68° F)	2.3 –2.9 V
			When engine coolant temperature is 40° C (104° F)	1.3 –1.9 V
			When engine coolant temperature is 60° C (140° F)	0.7 –1.3 V
			When engine coolant temperature is 80° C (176° F)	0.3 –0.9 V
34	Heated oxygen sensor (front) heater	Engine: warming up, idling (20 seconds after starting engine)	9 –11 V* ¹	
		Engine: revving	9 –11 V* ¹ →B+ (momentarily)	
35	Heated oxygen sensor (rear) heater	Engine warming up, idling (20 seconds after starting engine)	9 –11 V* ¹	
		Engine: revving	9 –11 V* ¹ →B+ (momentarily)	
36	Engine oil pressure switch	Ignition switch: "ON"	1 V or less	
		Engine: idling	B+	
37	Evaporative emission purge solenoid	Ignition switch: "ON"	B+	
		Engine: warming up, 3,000 r/min (with 3 minutes after the engine starting sequence is completed)	Voltage drops	
38	Heated oxygen sensor (front)	Engine: warming up, 2,500 r/min	0.5 ⇔ 1.4 V (changes repeatedly)	
39	Heated oxygen sensor (front) offset voltage	Ignition switch: "ON"	0.4 –0.6 V	
40	Heated oxygen sensor (rear)	<ul style="list-style-type: none"> Transaxle: 2nd Drive with wide open throttle Engine: 3,500 r/min or more 	1.0 –1.5 V	
41	Heated oxygen sensor (rear) offset voltage	Ignition switch: "ON"	0.4 –0.6 V	

TERMINAL NO.	INSPECTION ITEM	INSPECTION CONDITION (ENGINE CONDITION)		NORMAL CONDITION
44	Power supply voltage applied to manifold absolute pressure sensor	Ignition switch: "ON"		4.9 –5.1 V
45	Manifold absolute pressure sensor	Ignition switch: "ON"	At altitude of 0 m (0 ft.)	1.2 –1.8 V
			At altitude of 600 m (1,969 ft.)	1.1 –1.7 V
			At altitude of 1,200 m (3,937 ft.)	1.0 –1.6 V
			At altitude of 1,800 m (5,906 ft.)	0.9 –1.5 V
		Engine: warming up, idling		0.46 –0.66 V
When engine is suddenly revved		Voltage varies		
51	Fuel pump relay 1	Engine: While engine is idling after having warmed up, suddenly depress the accelerator pedal.		From battery voltage, it is slightly reduced temporarily.
52	Turbocharger wastegate solenoid 1	Engine: Warming up	Engine is idling	B+
			When engine is suddenly revved	Voltage drops
53	Turbocharger wastegate solenoid 2	Engine: Warming up	Engine is idling	B+
			4,000 r/min	Voltage drops
58	Power steering pressure switch	Engine: warming up, idling	When steering wheel is not turned	B+
			When steering wheel is turned	1 V or less
60	Generator G terminal	<ul style="list-style-type: none"> • Engine: warming up, idling • Radiator fan: stopped • Headlight: OFF to ON*2 • Stop light: OFF to ON • Rear defogger switch: OFF to ON 		Voltage increases
61	Generator FR terminal	<ul style="list-style-type: none"> • Engine: warming up, idling • Radiator fan: stopped • Headlight: OFF to ON*2 • Stop light: OFF to ON • Rear defogger switch: OFF to ON 		Voltage drops
62	Generator L terminal	Ignition switch: "ON"		0.5 –2.0 V
		Engine: idling		B+
72	Power supply voltage applied to throttle actuator control motor	Ignition switch: "ON"		B+
73	MFI relay (power supply)	Ignition switch: "LOCK" (OFF)		B+
		Ignition switch: "ON"		1 V or less

TERMINAL NO.	INSPECTION ITEM	INSPECTION CONDITION (ENGINE CONDITION)		NORMAL CONDITION
74	Accelerator pedal position sensor (main)	Ignition switch: "ON"	Release the accelerator pedal	0.9 –1.1 V
			Depress the accelerator pedal fully	4 V or more
75	Power supply voltage applied to accelerator pedal position sensor (main)	Ignition switch: "ON"		4.9 –5.1 V
77	Accelerator pedal position sensor (sub)	Ignition switch: "ON"	Release the accelerator pedal	0.4 –0.6 V
			Depress the accelerator pedal fully	2 V or more
78	Power supply voltage applied to accelerator pedal position sensor (sub)	Ignition switch: "ON"		4.9 –5.1 V
82	Power supply	Ignition switch: "ON"		B+
84	Throttle actuator control motor relay	Ignition switch: "ON" →"LOCK" (OFF)		1 V or less →B+ → 1 V or less
85	Clutch pedal position switch <M/T>	Ignition switch: "ON"	Release the clutch pedal	10 V or more
			Depress the clutch pedal fully	1 V or less
87	Mass airflow sensor	Engine is revved		Voltage increases in response to revving
89	Intake air temperature sensor 1	Ignition switch: "ON"	When intake air temperature is -20° C (-4° F)	3.8 –4.4 V
			When intake air temperature is 0° C (32° F)	3.2 –3.8 V
			When intake air temperature is 20° C (68° F)	2.3 –2.9 V
			When intake air temperature is 40° C (104° F)	1.5 –2.1 V
			When intake air temperature is 60° C (140° F)	0.8 –1.4 V
			When intake air temperature is 80° C (176° F)	0.4 –1.0 V
92	Ignition switch-IG	Ignition switch: "ON"		B+
96	Fuel pump relay 2	Ignition switch: "ON"		B+
		Engine: idling		1.0 V or less

TERMINAL NO.	INSPECTION ITEM	INSPECTION CONDITION (ENGINE CONDITION)	NORMAL CONDITION	
98	Intake air temperature sensor 2	Ignition switch: "ON"	When intake air temperature is -20° C (-4° F)	3.8 –4.4 V
			When intake air temperature is 0° C (32° F)	3.2 –3.8 V
			When intake air temperature is 20° C (68° F)	2.3 –2.9 V
			When intake air temperature is 40° C (104° F)	1.5 –2.1 V
			When intake air temperature is 60° C (140° F)	0.8 –1.4 V
			When intake air temperature is 80° C (176° F)	0.4 –1.0 V
102	A/C compressor clutch relay	<ul style="list-style-type: none"> • Engine: idling • A/C switch: OFF →ON (A/C compressor is operating) 	B+ →1 V or less as A/C clutch cycles	
104	Backup power supply	Ignition switch: "LOCK" (OFF)	B+	
105	Ignition switch-ST	Ignition switch: cranking	8 V or more	
106	Starter relay	Engine: cranking	B+	
		Engine: idling	1 V or less	
112	Fuel tank differential pressure sensor	<ul style="list-style-type: none"> • Ignition switch: "ON" • Fuel cap removal 	1.5 –3.5 V	
114	Power supply voltage applied to fuel tank differential pressure sensor	Ignition switch: "ON"	4.9 –5.1 V	
115	Fuel tank temperature sensor	Ignition switch: "ON"	When fuel tank temperature is 0° C (32° F)	2.7 –3.1 V
			When fuel tank temperature is 20° C (68° F)	2.1 –2.5 V
			When fuel tank temperature is 40° C (104° F)	1.6 –2.0 V
			When fuel tank temperature is 80° C (176° F)	0.8 –1.2 V
117	Evaporative emission ventilation solenoid	Ignition switch: "ON"	B+	
		Carry out the actuator test to drive the solenoid valve.	1 V or less (Approximately 6 seconds)	

TERMINAL RESISTANCE AND CONTINUITY CHECK

Engine-ECU harness side connector

B-10

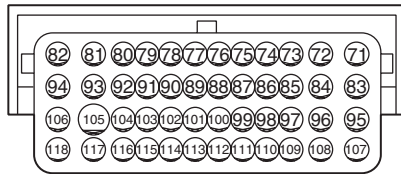

B-09

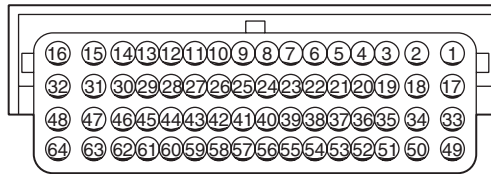

AK502911AT

TERMINAL NO.	INSPECTION ITEM	NORMAL CONDITION (INSPECTION CONDITION)
1 –82	Intake engine oil control valve	6.9 –7.9 Ω [at 20° C (68° F)]
15 –16	Throttle actuator control motor	0.3 –80 Ω [at 20° C (68° F)]
17 –82	Exhaust engine oil control valve	6.9 –7.9 Ω [at 20° C (68° F)]
26 –27	Engine coolant temperature sensor	14 –17 kΩ [when engine coolant temperature is –20° C (–4° F)]
		5.1 –6.5 kΩ [when engine coolant temperature is 0° C (32° F)]
		2.1 –2.7 kΩ [when engine coolant temperature is 20° C (68° F)]
		0.9 –1.3 kΩ [when engine coolant temperature is 40° C (104° F)]
		0.48 –0.68 kΩ [when engine coolant temperature is 60° C (140° F)]
		0.26 –0.36 kΩ [when engine coolant temperature is 80° C (176° F)]
34 –82	Heated oxygen sensor (front) heater	4.5 –8.0 Ω [at 20° C (68° F)]
35 –82	Heated oxygen sensor (rear) heater	4.5 –8.0 Ω [at 20° C (68° F)]
37 –82	Evaporative emission purge solenoid	22 –26 Ω [at 20° C (68° F)]
52 –82	Turbocharger wastegate solenoid 1	29 –35 Ω [at 20° C (68° F)]
53 –82	Turbocharger wastegate solenoid 2	29 –35 Ω [at 20° C (68° F)]
71 –Body ground	ECM ground	Continuity (2 Ω or less)
81 –Body ground		
83 –Body ground		
93 –Body ground		
82 –117	Evaporative emission ventilation solenoid	17 –21 Ω [at 20° C (68° F)]

TERMINAL NO.	INSPECTION ITEM	NORMAL CONDITION (INSPECTION CONDITION)
88 –89	Intake air temperature sensor 1	13 –17 kΩ [when intake air temperature is -20° C (-4° F)]
		5.4 –6.6 kΩ [when intake air temperature is 0° C (32° F)]
		2.3 –3.0 kΩ [when intake air temperature is 20° C (68° F)]
		1.0 –1.5 kΩ [when intake air temperature is 40° C (104° F)]
		0.56 –0.76 kΩ [when intake air temperature is 60° C (140° F)]
		0.31 –0.43 kΩ [when intake air temperature is 80° C (176° F)]
97 –98	Intake air temperature sensor 2	13 –18 kΩ [when intake air temperature is -20° C (-4° F)]
		5.1 –6.9 kΩ [when intake air temperature is 0° C (32° F)]
		2.0 –3.0 kΩ [when intake air temperature is 20° C (68° F)]
		0.9 –1.5 kΩ [when intake air temperature is 40° C (104° F)]
		0.40 –0.78 kΩ [when intake air temperature is 60° C (140° F)]
		0.23 –0.42 kΩ [when intake air temperature is 80° C (176° F)]

INSPECTION PROCEDURE USING AN OSCILLOSCOPE

M1131154502301

**INTAKE CAMSHAFT POSITION SENSOR AND
CRANKSHAFT POSITION SENSOR**

Required Special Tools:

- MB991709: Test Harness
- MB992110: Power Plant ECU Check Harness

Measurement Method

1. Disconnect the intake camshaft position sensor connector, and connect the test harness special tool (MB991709) between the separated connector (All terminals should be connected).
2. Connect the oscilloscope probe to intake camshaft position sensor connector terminal No. 3.
3. Disconnect the crankshaft position sensor connector, and connect the test harness special tool (MB991709) between the separated connector.
4. Connect the oscilloscope probe to crankshaft position sensor connector terminal No. 3.

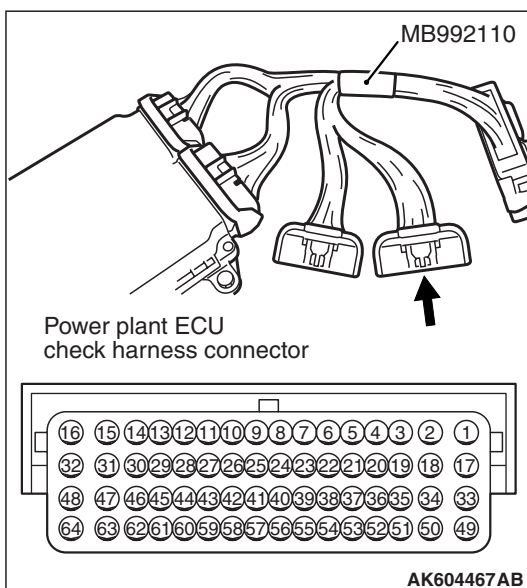
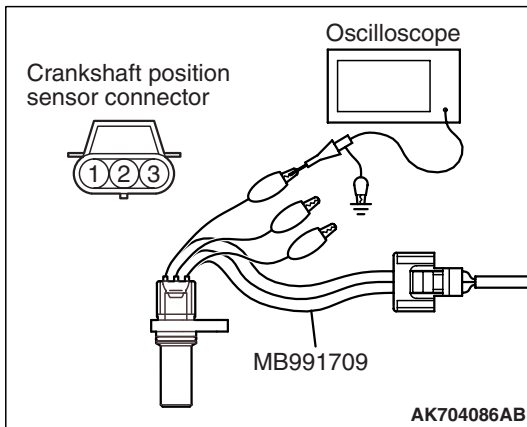
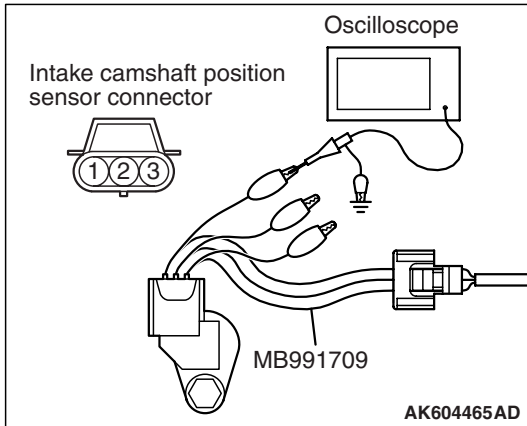

Alternate method

1. Disconnect all ECM connectors. Connect the check harness special tool (MB992110) between the separated connectors.

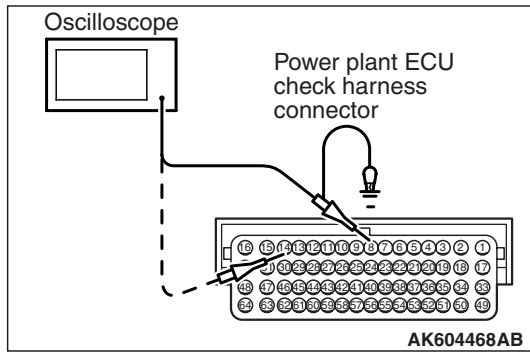

2. Connect the oscilloscope to check harness terminal No. 14. (Check the intake camshaft position sensor signal wave pattern.)
3. Connect the oscilloscope to check harness terminal No. 8. (Check the crankshaft position sensor signal wave pattern.)

Standard Wave Pattern

Observation condition	
Function	Special pattern
Pattern height	Low
Pattern selector	Display
Engine r/min	Idle speed

Standard wave pattern

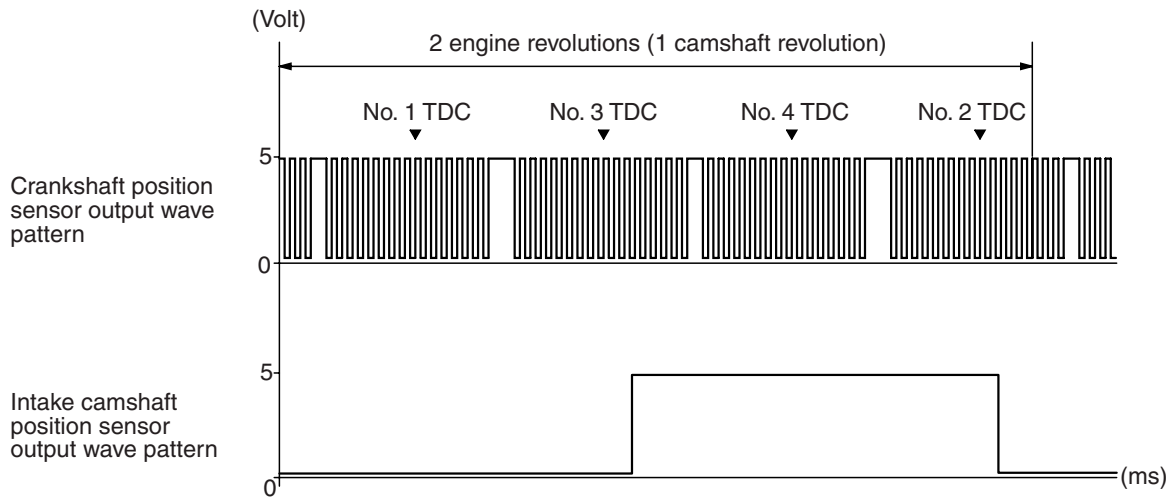

AK703687AD

Wave Pattern Observation Points

1. Check that cycle time becomes shorter when the engine speed increased.

Examples of Abnormal Wave Patterns

Example 1

Cause of problem

- Sensor interface malfunction.

Wave pattern characteristics

- Rectangular wave pattern is output even when the engine is not started.

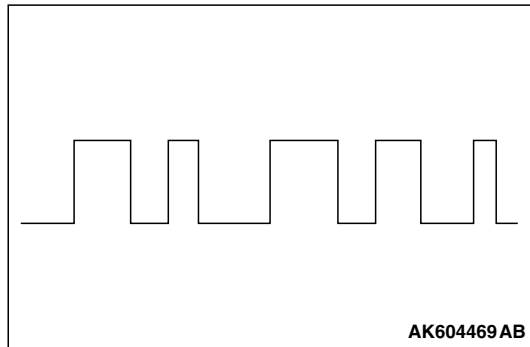

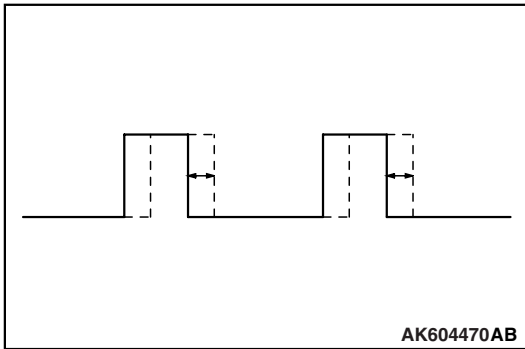

Example 2

Cause of problem

- Loose timing belt.
- Abnormality in sensor disc.

Wave pattern characteristics

- Wave pattern is displaced to the left or right.

**EXHAUST CAMSHAFT POSITION SENSOR AND
CRANKSHAFT POSITION SENSOR**

Required Special Tools:

- MB991709: Test Harness
- MB992110: Power Plant ECU Check Harness

Measurement Method

1. Disconnect the exhaust camshaft position sensor connector, and connect the test harness special tool (MB991709) between the separated connector (All terminals should be connected).
2. Connect the oscilloscope probe to exhaust camshaft position sensor connector terminal No. 3.
3. Disconnect the crankshaft position sensor connector, and connect the test harness special tool (MB991709) between the separated connector.
4. Connect the oscilloscope probe to crankshaft position sensor connector terminal No. 3.

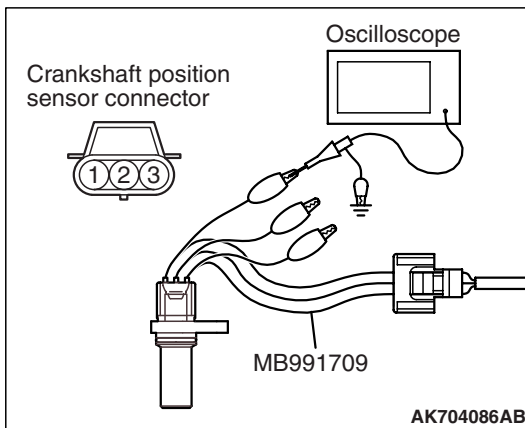
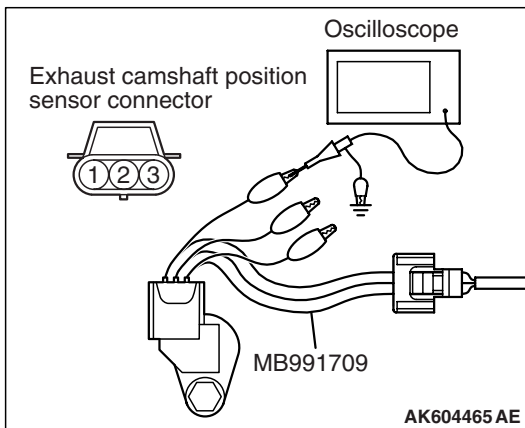

Alternate method

1. Disconnect all ECM connectors. Connect the check harness special tool (MB992110) between the separated connectors.

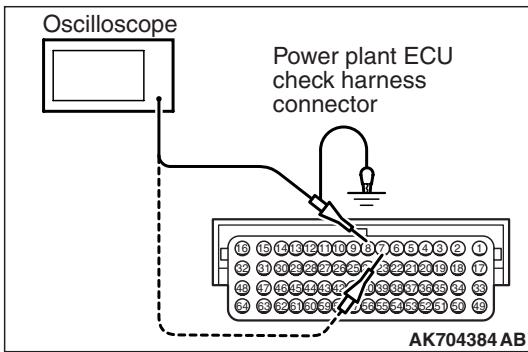
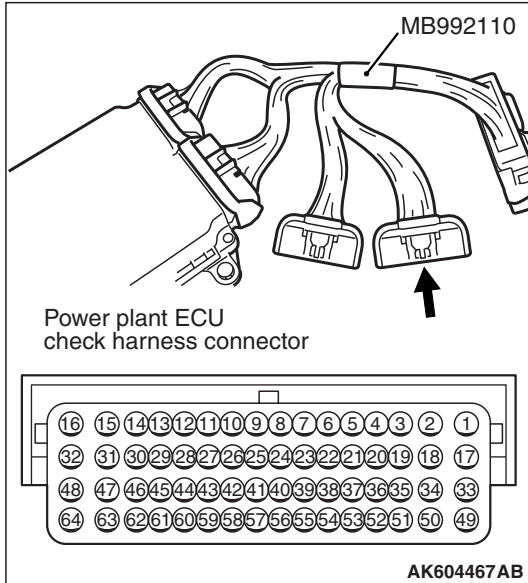

2. Connect the oscilloscope to check harness terminal No. 7. (Check the exhaust camshaft position sensor signal wave pattern.)
3. Connect the oscilloscope to check harness terminal No. 8. (Check the crankshaft position sensor signal wave pattern.)

Standard Wave Pattern

Observation condition	
Function	Special pattern
Pattern height	Low
Pattern selector	Display
Engine r/min	Idle speed

Standard wave pattern

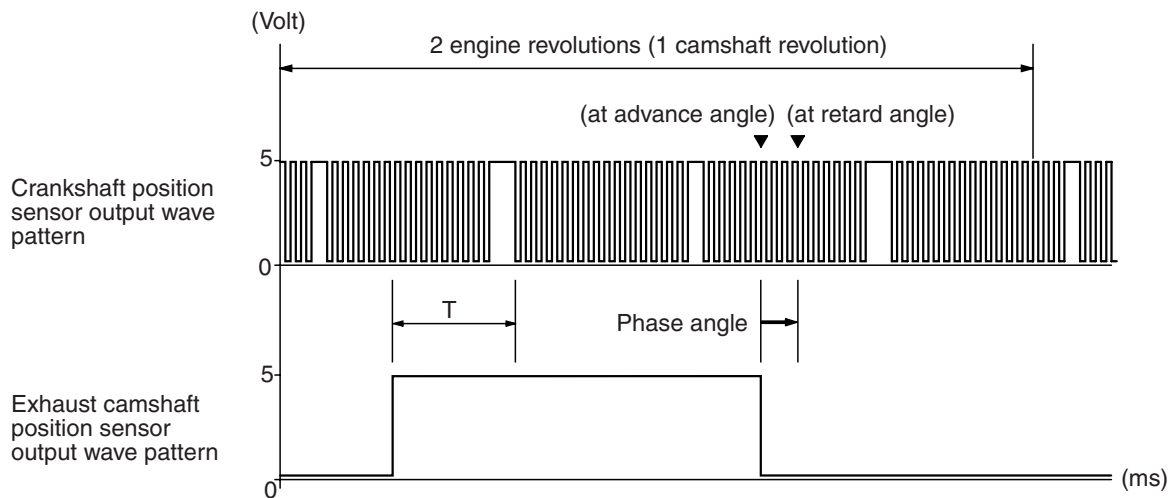

AK703482AE

Wave Pattern Observation Points

- Verify that, toward the engine speed of 2,500 r/min, time difference T from when the crankshaft position sensor output wave falls to when the exhaust camshaft position sensor output wave falls becomes less.

Examples of Abnormal Wave Patterns

Example 1

Cause of problem

- Sensor interface malfunction.

Wave pattern characteristics

- Rectangular wave pattern is output even when the engine is not started.

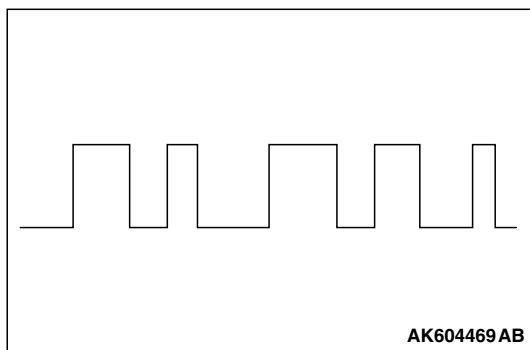

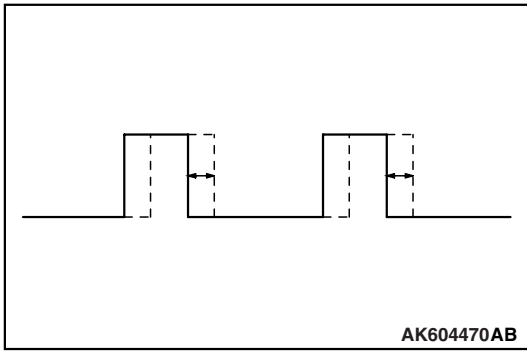

Example 2

Cause of problem

- Loose timing belt.
- Abnormality in sensor disc.

Wave pattern characteristics

- Wave pattern is displaced to the left or right.

INJECTOR

Required Special Tools:

- MB991658: Test Harness
- MB992110: Power Plant ECU Check Harness

Measurement Method

1. Disconnect the injector connector, and connect the test harness special tool (MB991658) between the separated connector. (All terminals should be connected.)
2. Connect the oscilloscope probe to injector connector terminal No. 2.

Alternate method

1. Disconnect all ECM connectors. Connect the check harness special tool (MB992110) between the separated connectors.

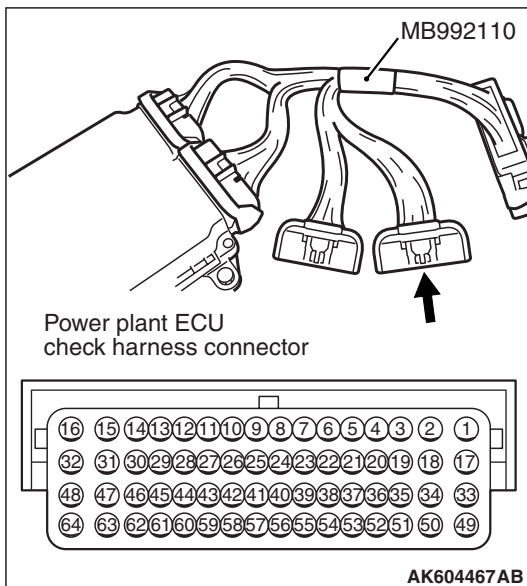
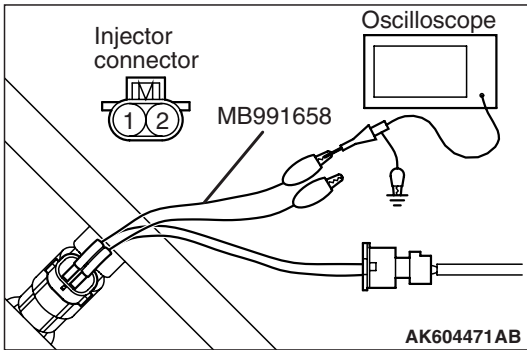

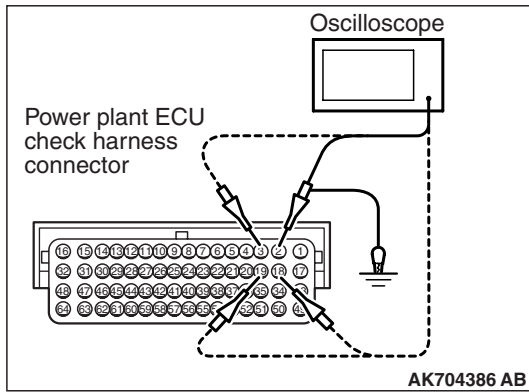

2. Connect the oscilloscope probe to each check harness connector terminal to analyze each cylinder:

- Terminal No. 2 for the number 1 cylinder.
- Terminal No. 3 for the number 2 cylinder.
- Terminal No. 18 for the number 3 cylinder.
- Terminal No. 19 for the number 4 cylinder.

Standard Wave Pattern

Observation conditions	
Function	Special pattern
Pattern height	Variable
Variable knob	Adjust while viewing the wave pattern
Pattern selector	Display
Engine r/min	Idle speed

Standard wave pattern

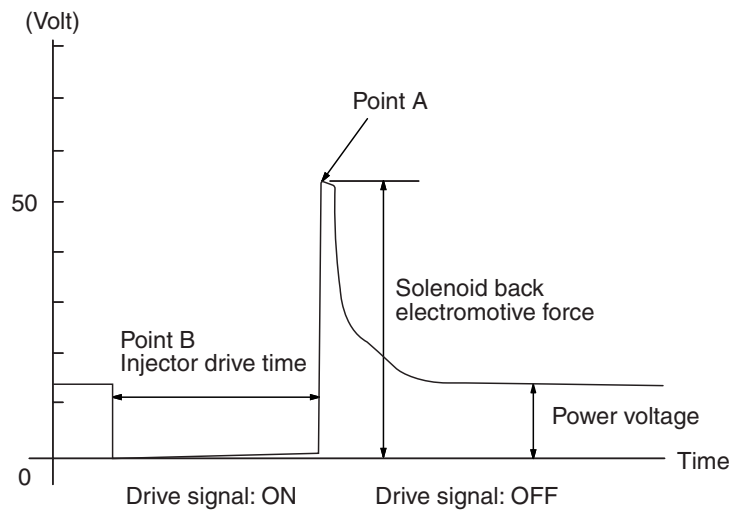

AK703483AD

Wave Pattern Observation Points

Point A: Height of injector coil induced voltage.

CONTRAST WITH STANDARD WAVE PATTERN	PROBABLE CAUSE
Injector coil induced voltage is low or doesn't appear at all	Short in the injector solenoid

Point B: Injector drive time

1. The injector drive time should be synchronized with the scan tool tester display.
2. When the engine is suddenly revved, the drive time will be greatly extended at first, but the drive time will soon return to original length.

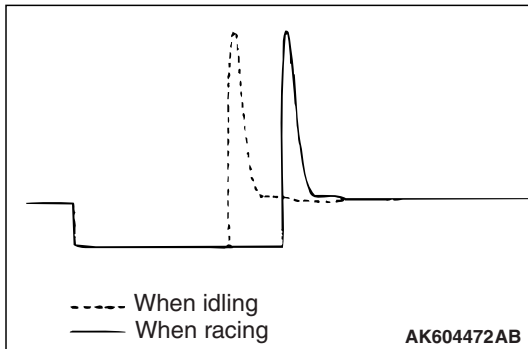

IGNITION COIL AND IGNITION POWER TRANSISTOR

Required Special Tools:

- MB991658: Test Harness
- MB992110: Power Plant ECU Check Harness

Measurement Method

1. Disconnect the ignition coil connector, and connect test harness special tool (MB991658) between the separated connector. (All terminals should be connected.)
2. Connect the oscilloscope probe to ignition coil connector terminal No. 2.

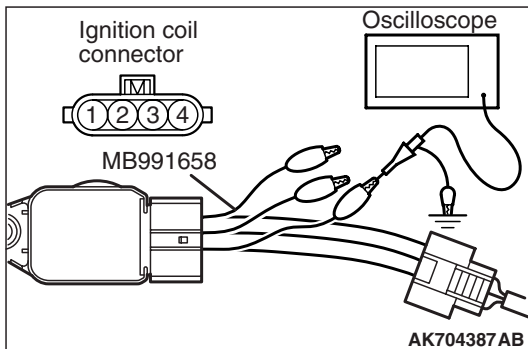

Alternate method

1. Disconnect all ECM connectors. Connect the check harness special tool (MB992110) between the separated connectors.

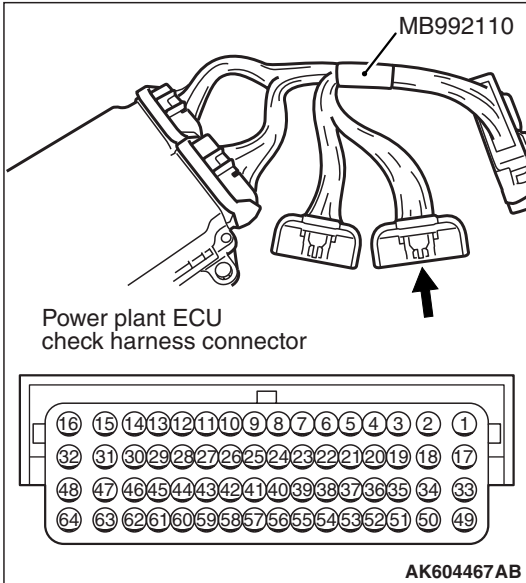

2. Connect the oscilloscope probe to each check harness connector terminal to analyze each cylinder:
 - Terminal No. 4 for the number 1 cylinder.
 - Terminal No. 5 for the number 2 cylinder.
 - Terminal No. 20 for the number 3 cylinder.
 - Terminal No. 21 for the number 4 cylinder.

Standard Wave Pattern

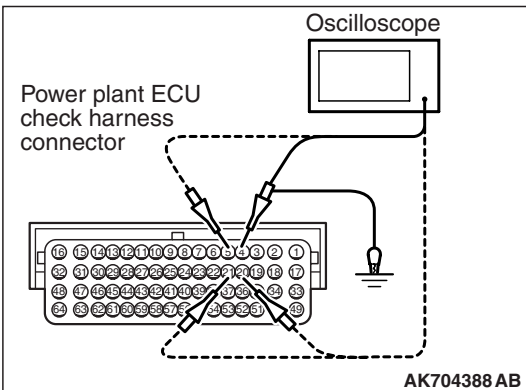

Observation condition	
Function	Special pattern
Pattern height	Low
Pattern selector	Display
Engine r/min	Idle speed

Standard wave pattern

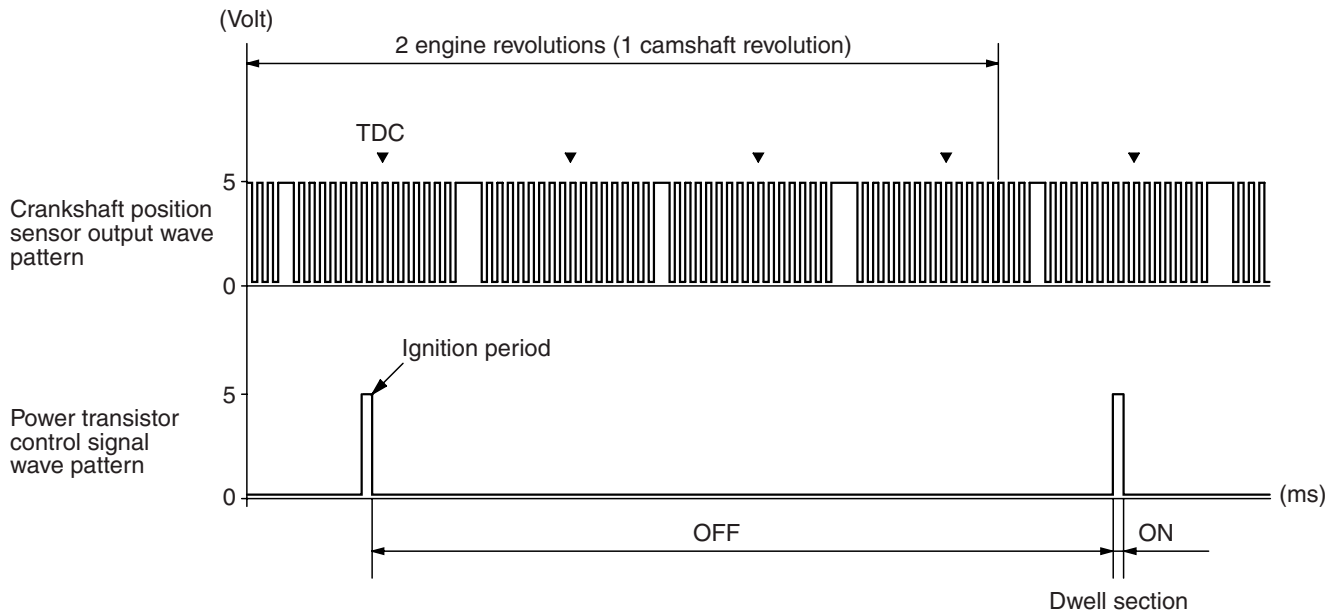

AK604736AB

Wave Pattern Observation Points

Point: The power transistor control signal (ignition timing) is advanced when the engine speed is increased.

CONDITION OF WAVE PATTERN BUILD-UP SECTION AND MAXIMUM VOLTAGE	PROBABLE CAUSE
Voltage value is too low	Open-circuit in ignition primary circuit

Examples of Abnormal Wave Patterns

Example 1 (Wave pattern during engine cranking)

- Cause of problem
Open-circuit in ignition primary circuit
- Wave pattern characteristics
Voltage value is too low.

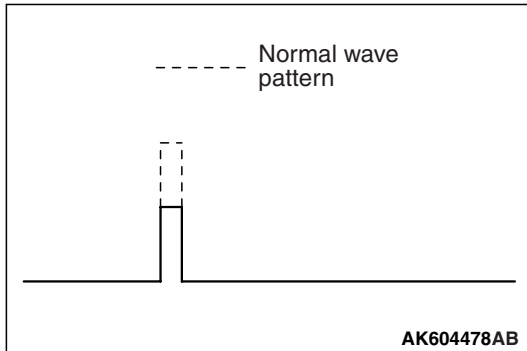

AK604478AB

ON-VEHICLE SERVICE

COMPONENT LOCATION

M1131002102424

NAME	SYMBOL	NAME	SYMBOL
Accelerator pedal position sensor	V	Heated oxygen sensor (rear)	X
A/C compressor clutch relay	Q	Ignition coil	D
Clutch pedal position switch <M/T>	T	Injector	C
Crankshaft position sensor	O	Injector relay	Q
Data link connector	U	Intake air temperature sensor 2	L
Engine control module	P	Intake camshaft position sensor	L
Engine coolant temperature sensor	F	Intake engine oil control valve	A
ETACS-ECU (incorporating fuel pump relay 2)	S	Knock sensor	M
Evaporative emission purge solenoid	N	Malfunction Indicator Lamp (SERVICE ENGINE SOON or Check Engine Lamp)	R
Evaporative emission ventilation solenoid	Z	Manifold absolute pressure sensor	K
Exhaust camshaft position sensor	E	Mass airflow sensor (incorporating intake air temperature sensor 1)	H
Exhaust engine oil control valve	B	MFI relay	Q
Fuel level sensor (sub)	W	Power steering pressure switch	J
Fuel pump circuit resistor	I	Starter relay	Q
Fuel pump module (incorporating fuel level sensor (main) and fuel tank temperature sensor)	Y	Throttle actuator control motor relay	Q
Fuel pump relay 1	Q	Throttle body assembly (incorporating throttle actuator control motor and throttle position sensor)	L
Fuel tank differential pressure sensor	Y	Turbocharger wastegate solenoid 1	G
Heated oxygen sensor (front)	X	Turbocharger wastegate solenoid 2	G

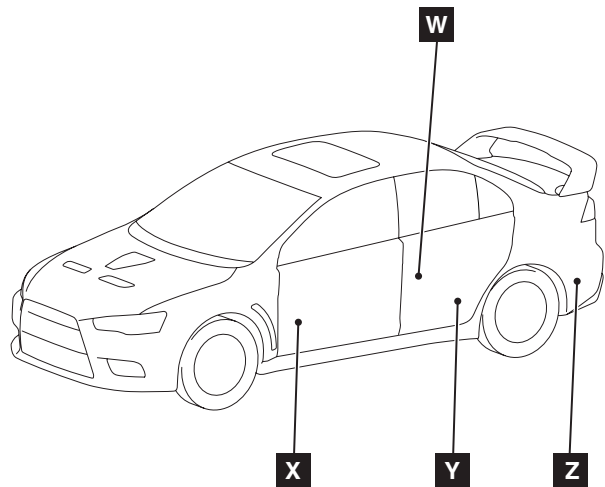
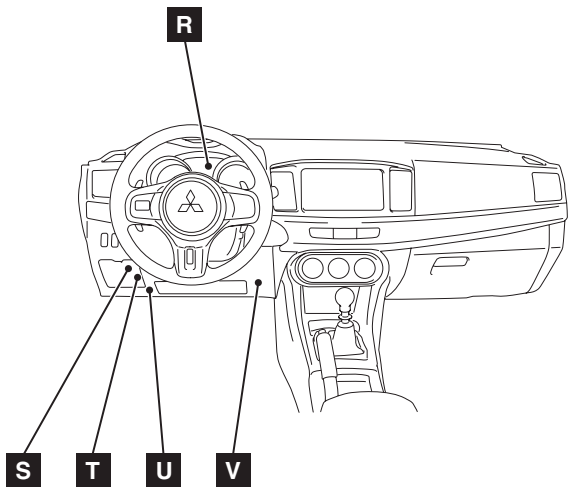
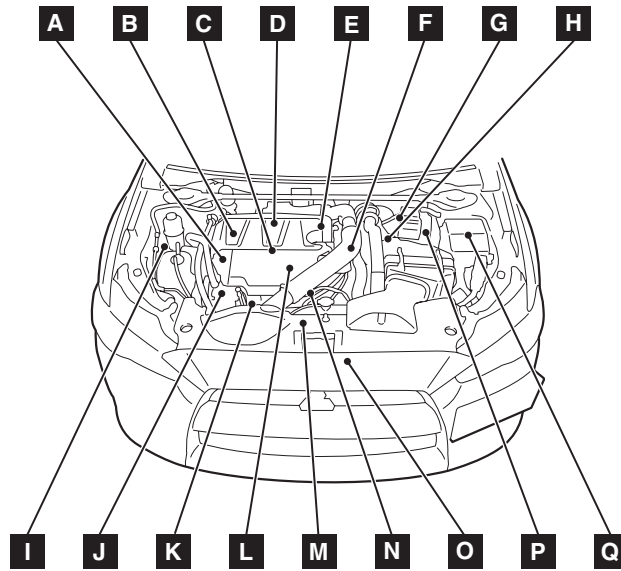

AK704051AB

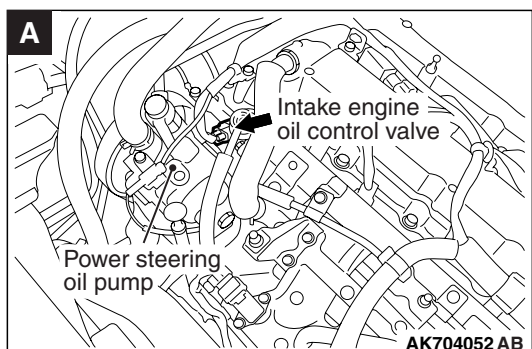

AK704052 AB

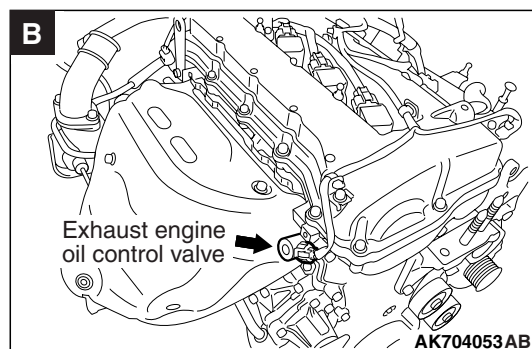

AK704053AB

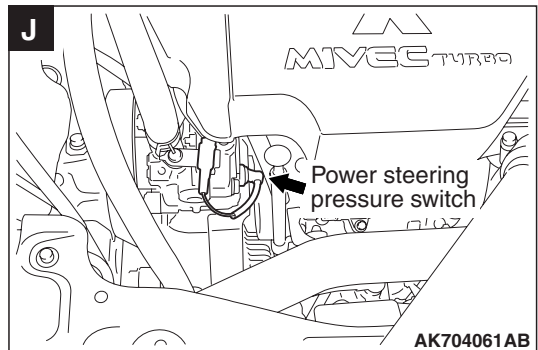
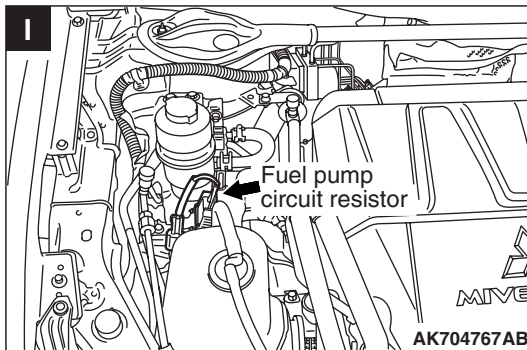
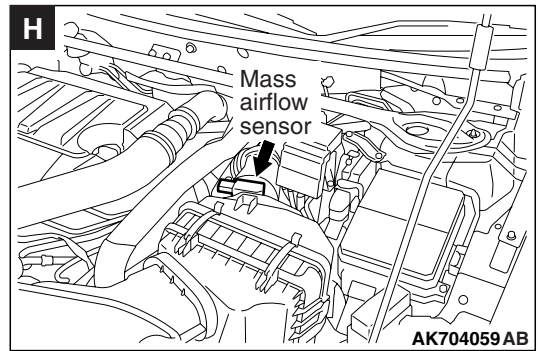
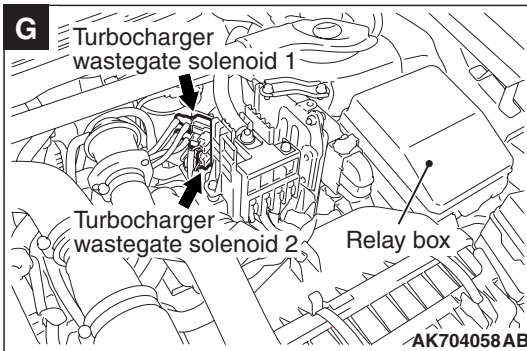
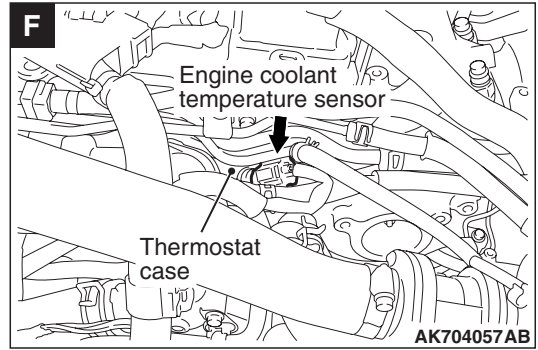
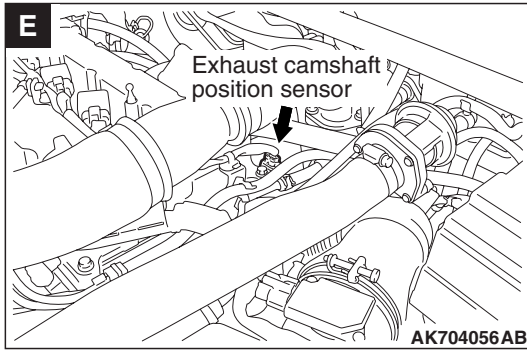
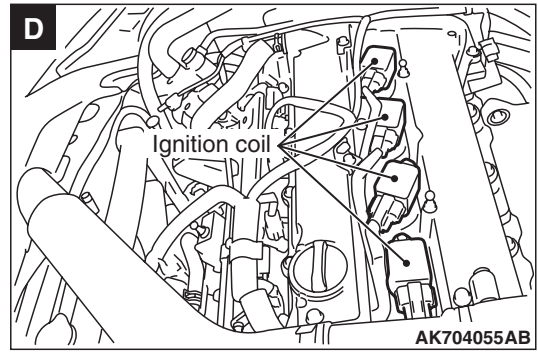
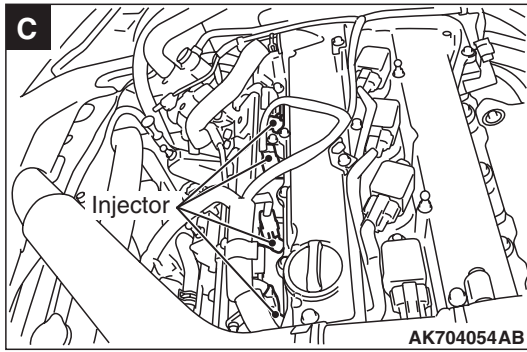

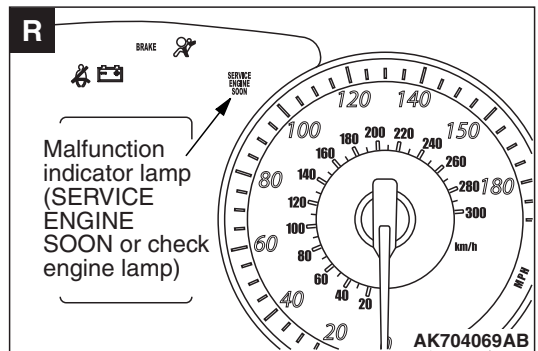
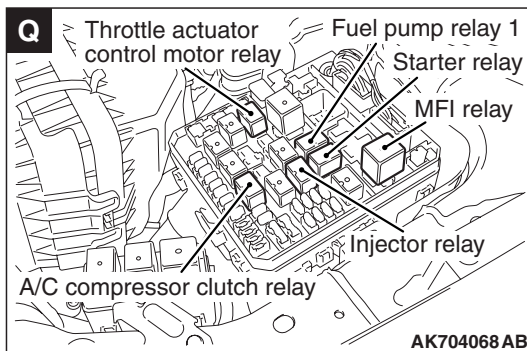
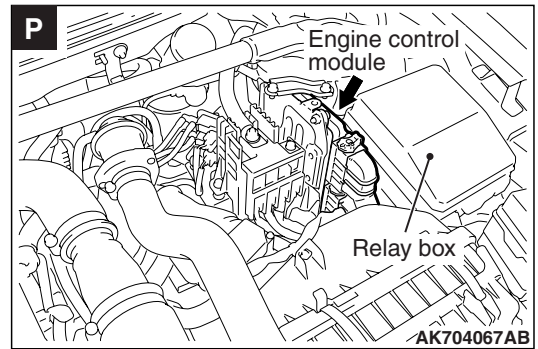
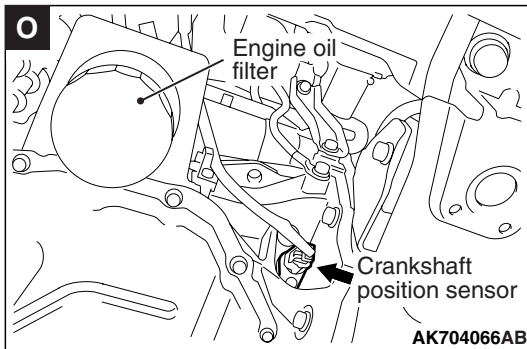
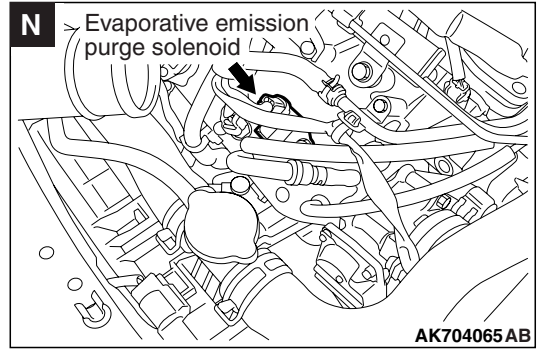
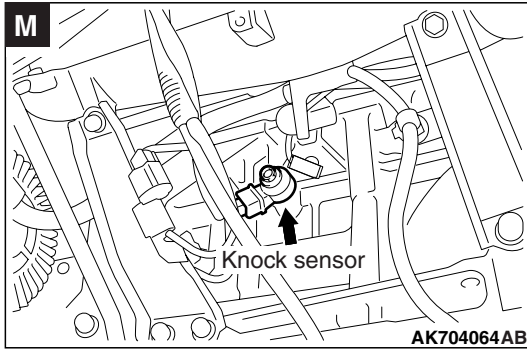
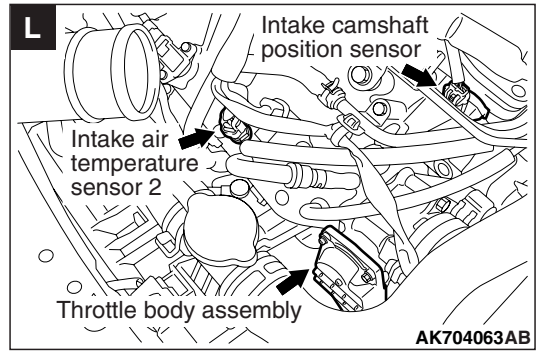
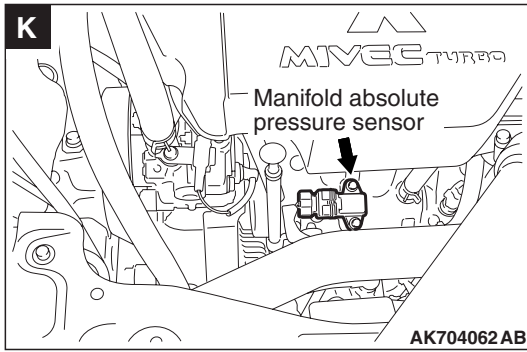

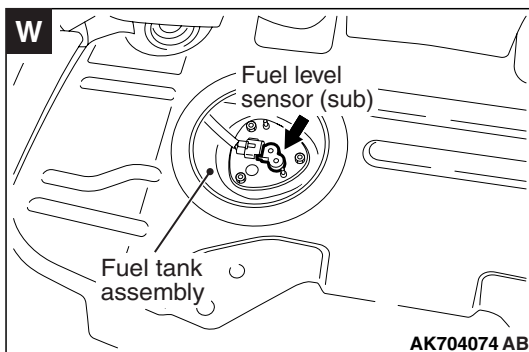
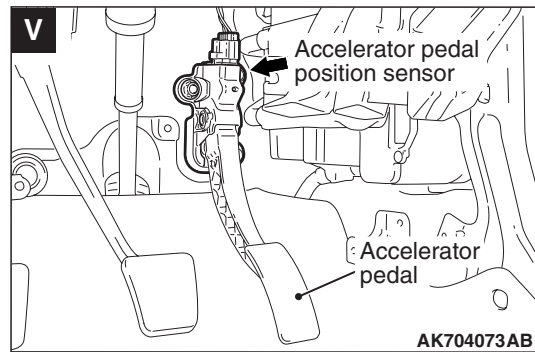
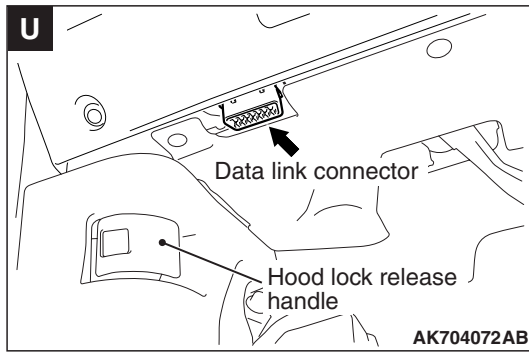
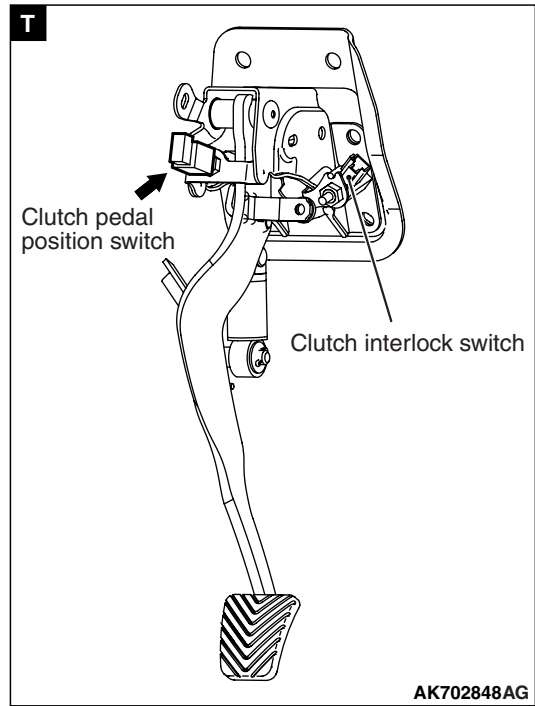
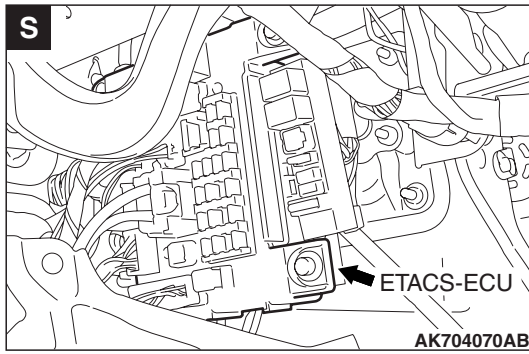

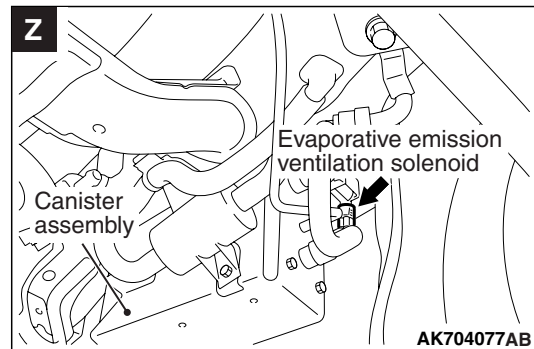
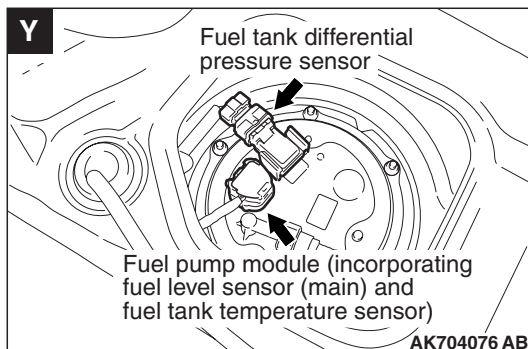
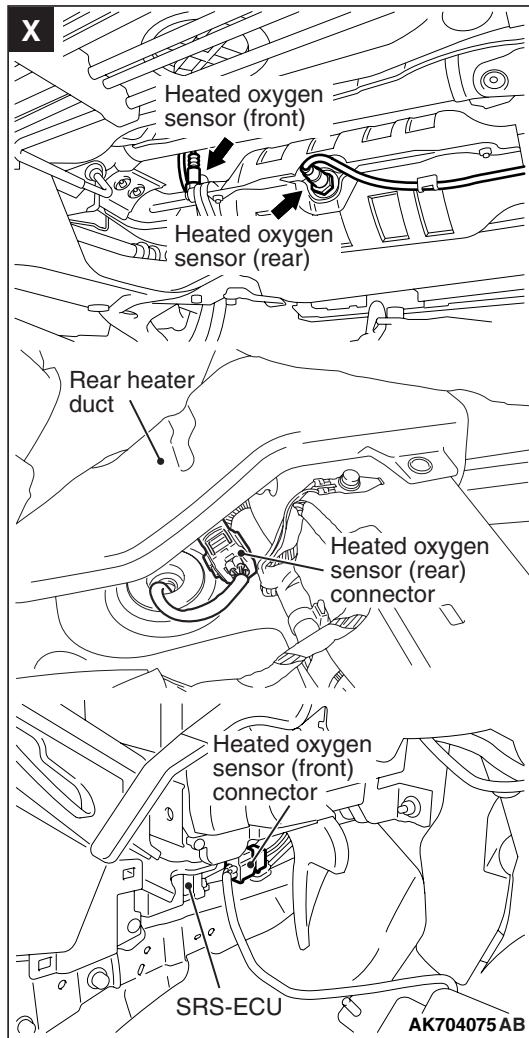

THROTTLE BODY (THROTTLE VALVE AREA) CLEANING

M1131001001625

WARNING

When touching the throttle valve, surely shut off the driving circuits of the throttle valve. In the event that the throttle valve is operated, a finger might be injured as the result of being caught by the throttle valve.

CAUTION

When the throttle body cleaning is performed, use scan tool MB991958 to initialize the learning value (Refer to GROUP 00, Precautions Before Service –Initialization Procedure for Learning Value in MFI Engine P.00-31).

1. Disconnect the electronic-controlled throttle valve connector.
2. Remove the air intake hose from the throttle body.
3. Remove the throttle body.

CAUTION

Do not spray the cleaning solvent directly to the throttle valve.

4. Spray cleaning solvent on a clean cloth.

CAUTION

Make sure the cleaning solvent does not enter the motor and the sensor through the shaft.

5. Wipe off the dirt around the throttle valve with the cloth sprayed with cleaning solvent.
6. Install the throttle body.
7. Install the air intake hose.
8. Connect the electronic-controlled throttle valve connector.

FUEL PRESSURE TEST

M1131001902007

Required Special Tools:

- MB991958: Scan tool (M.U.T.-III Sub Assembly)
 - MB991824: V.C.I.
 - MB991827: USB Cable
 - MB991910: Main Harness A
- MB991981: Fuel Pressure Gauge Set
- MB992001: Hose Adapter
- MB992049: Quick Connector
- MB992076: Injector Test Set

1. Release residual pressure from the fuel line to prevent fuel spray. (Refer to P.13A-901.)

⚠ WARNING

To prevent a fire, cover the hose connection with shop towels to prevent splashing of fuel that could be caused by some residual pressure in the fuel pipe line.

2. Disconnect the fuel high-pressure hose at the fuel rail side.

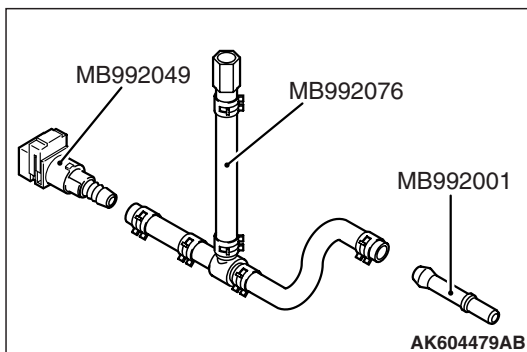
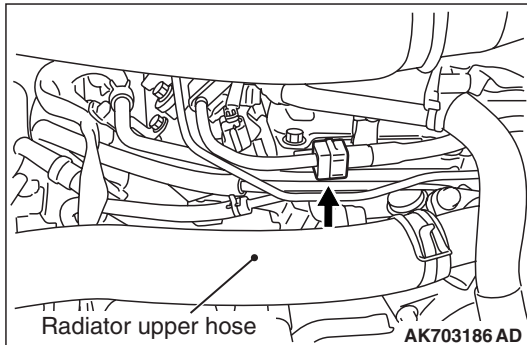

3. Assemble the special tool MB992076 (injector test set) as shown in figure according to the following procedure.

(1) Remove either the installation adapter for the injector or another adapter.

(2) Install the special tool MB992049 (quick connector) and the special tool MB992001 (hose adapter) to the hose without the adapter.

4. Install the special tool assembled in Step 3 between the fuel rail and the fuel high-pressure hose.

<When using the fuel pressure gauge>

a. Via a suitable O-ring or gasket, install the fuel pressure gauge to the special tool that has already assembled as described.

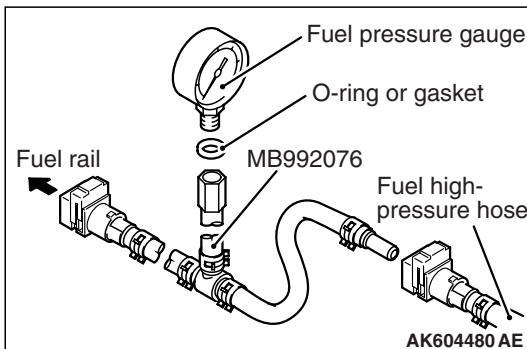
**<When using the special tool MB991981 (fuel pressure gauge set)>**

a. Via a gasket, install the special tool MB991981 (fuel pressure gauge set) into the special tool that has already assembled as described.

b. Connect the leads from the fuel pressure gauge set to the power supply (cigarette lighter socket) and special tool MB991824 (V.C.I).

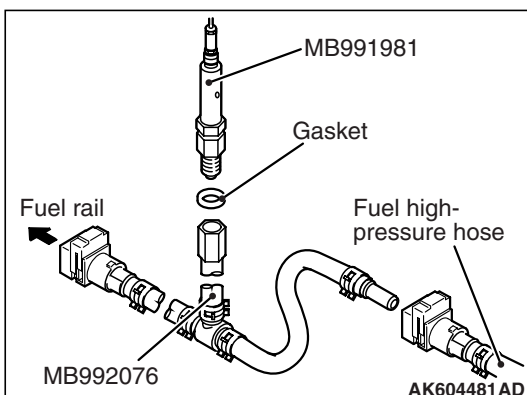

⚠ CAUTION

To prevent damage to scan tool MB991958, always turn the ignition switch to the "LOCK" (OFF) position before connecting or disconnecting scan tool MB991958.

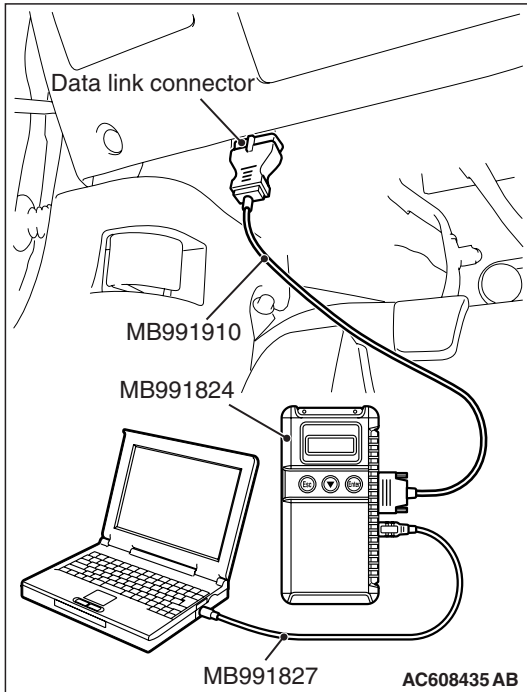

5. Connect scan tool MB991958 to the data link connector.
6. Turn the ignition switch to the ON position (But do not start the engine).
7. Use Actuator test "item number 9" to drive the fuel pump. Check that there is no fuel leaking from any section when the fuel pump is operating.
8. Finish the actuator test or turn the ignition switch to the LOCK (OFF) position.
9. Start the engine and run at idle.
10. Measure fuel pressure while the engine is running at idle.

Standard value: Approximately 260 kPa (38 psi) at curb idle

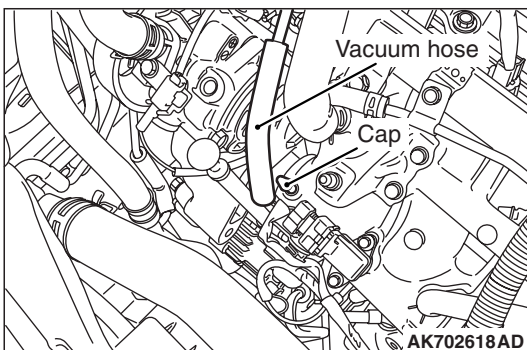

11. Remove the vacuum hose from the intake manifold and measure fuel pressure after the nipple closed with a cap.
Standard value: 310 –345 kPa (45 –50 psi) at curb idle
12. Check to see that fuel pressure at idle does not drop even after the engine has been revved several times.
13. Revving the engine repeatedly, hold the fuel return hose lightly with your fingers to feel that fuel pressure is present in the return hose.

NOTE: If the fuel flow rate is low, there will be no fuel pressure in the return hose.

14. If any of fuel pressure measured in Step 10 to 13 is out of specification, troubleshoot and repair according to the table below.

SYMPTOM	PROBABLE CAUSE	REMEDY
<ul style="list-style-type: none"> • Fuel pressure too low • Fuel pressure drops after revving • No fuel pressure in fuel return hose 	Clogged fuel filter	Replace fuel filter
	Fuel leaking to return side due to poor fuel regulator valve seating or settled spring	Replace fuel pressure regulator
	Low fuel pump delivery pressure	Replace fuel pump

SYMPTOM	PROBABLE CAUSE	REMEDY
Fuel pressure too high	Binding valve in fuel pressure regulator	Replace fuel pressure regulator
	Clogged fuel return hose or pipe	Clean or replace hose or pipe
Same fuel pressure when vacuum hose is connected and when disconnected	Damaged vacuum hose or clogged nipple	Replace vacuum hose or clean nipple
	Defective fuel pressure regulator	Replace fuel pressure regulator

15. Stop the engine and observe fuel pressure gauge reading. It is normal if the reading does not drop within 2 minutes. If it does, observe the rate of drop and troubleshoot and repair according to the table below. Start, then stop the engine.

(1) Squeeze the fuel return line closed to confirm leak-down occurs from defective fuel pressure regulator.

(2) If pressure continues to drop with fuel return line squeezed closed, injector(s) or fuel pump are leaking.

SYMPTOM	PROBABLE CAUSE	REMEDY
Fuel pressure drops gradually after engine is stopped	Leaky injector	Replace injector
	Leaky fuel regulator valve seat	Replace fuel pressure regulator
Fuel pressure drops sharply immediately after engine is stopped	Check valve in fuel pump is held open	Replace fuel pump

16. Release residual pressure from the fuel pipe line. (Refer to [P.13A-901.](#))

⚠ WARNING

Cover the hose connection with shop towels to prevent splash of fuel that could be caused by some residual pressure in the fuel pipe line.

17. Remove the fuel pressure gauge and special tool from the fuel rail.

18. Fit the fuel high-pressure hose to the fuel rail.

19. Check for fuel leaks.

(1) Use scan tool MB991958 to operate the fuel pump.

(2) Check the fuel line for leaks and repair as needed.

20. Disconnect scan tool MB991958.

FUEL PUMP CONNECTOR DISCONNECTION (HOW TO REDUCE PRESSURIZED FUEL PRESSURE)

M1131000901852

When removing the fuel pipes and fuel hoses, follow the procedure below to release fuel pressure in the line and prevent fuel from running out, because fuel pressure in the fuel line is high.

1. Remove the rear seat cushion assembly. (Refer to GROUP 52A, Rear Seat Assembly [P.52A-25](#)).
2. Remove the floor inspection lid (LH).

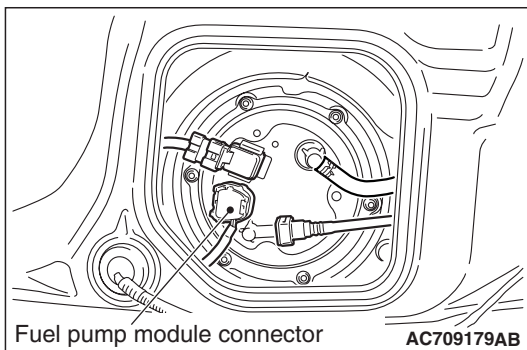
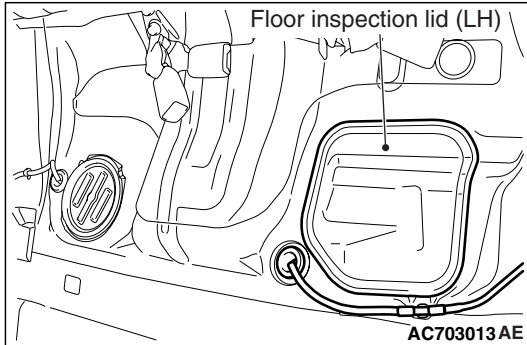

3. Disconnect the fuel pump module connector.
4. Crank the engine for two seconds or more, and turn the ignition switch to the "LOCK" (OFF) position.
NOTE: If the engine starts, wait until the engine stops by itself, then turn the ignition switch to the "LOCK" (OFF) position.
5. Connect the fuel pump module.
6. Install the floor inspection lid (LH).
7. Install the rear seat cushion assembly. (Refer to GROUP 52A, Rear Seat Assembly [P.52A-25](#)).

FUEL PUMP OPERATION CHECK

M1131002002171

1. Remove the fuel tank cap.
NOTE: The operating sound of the fuel tank pump is difficult to be heard because the pump is in-tank type. Therefore, remove the fuel filler cap to check the sound from the fuel filler port.
2. Using scan tool, forcibly drive the fuel tank pump (integrated in the fuel pump module) to check the fuel tank pump operation.
3. Install the fuel tank cap.
4. If the fuel tank pump does not operate, follow the procedure below to check the pump for operation. If it is normal, check the driving circuit.
 - (1) Turn the ignition switch to the "LOCK" (OFF) position.
 - (2) Remove the rear seat cushion assembly. (Refer to GROUP 52A, Rear Seat Assembly [P.52A-25](#)).

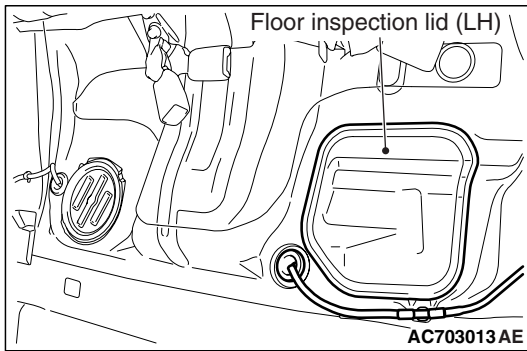

(3) Remove the floor inspection lid (LH).

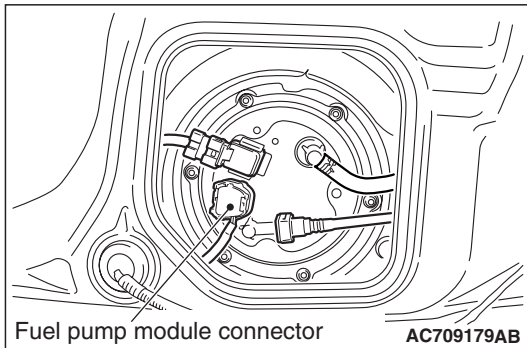

(4) Disconnect the fuel pump module connector.

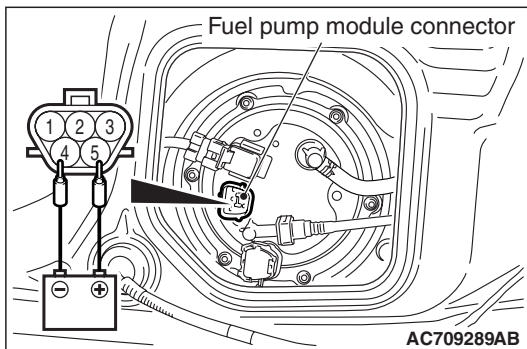

(5) When the battery is connected to the fuel pump module connector (fuel pump module side), check that the pump operating sound can be heard. When the pump operating sound cannot be heard, replace the fuel tank pump. (Refer to GROUP 13B, On-Vehicle Service –Fuel Pump Module Replacement [P.13B-6](#)).

NOTE: The operating sound of the fuel tank pump is difficult to be heard because the pump is in-tank type. Therefore, remove the fuel filler cap to check the sound from the fuel filler port.

(6) Connect the fuel pump module connector.

(7) Install the floor inspection lid (LH).

(8) Install the rear seat cushion assembly. (Refer to GROUP 52A, Rear Seat Assembly [P.52A-25](#)).

MULTIPOINT FUEL INJECTION (MFI) RELAY CONTINUITY CHECK

M1131050001434

Inspect the MFI relay for continuity in accordance with the chart shown below.

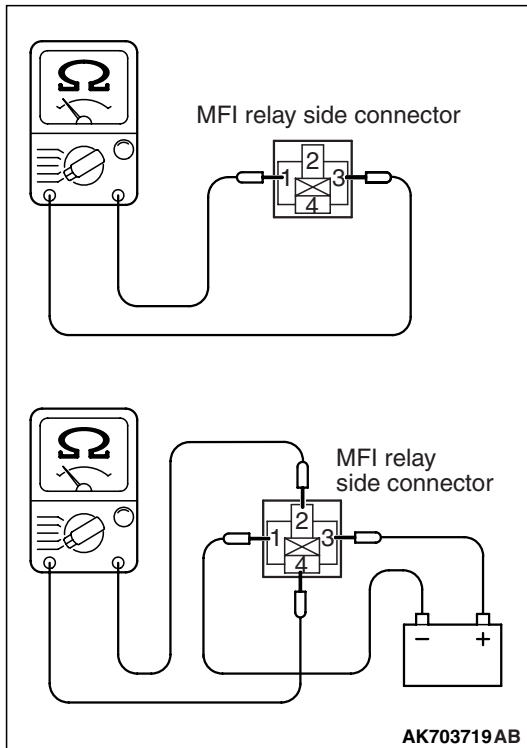

BATTERY VOLTAGE	TERMINAL NO. TO BE CONNECTED TO BATTERY	TERMINAL NO. TO BE CONDUCTED
Not supplied	–	1 –3
Supplied	1 –3	2 –4

FUEL PUMP RELAY CONTINUITY CHECK

M1131033001486

Fuel pump relay 1

Inspect the fuel pump relay 1 for continuity in accordance with the chart shown below.

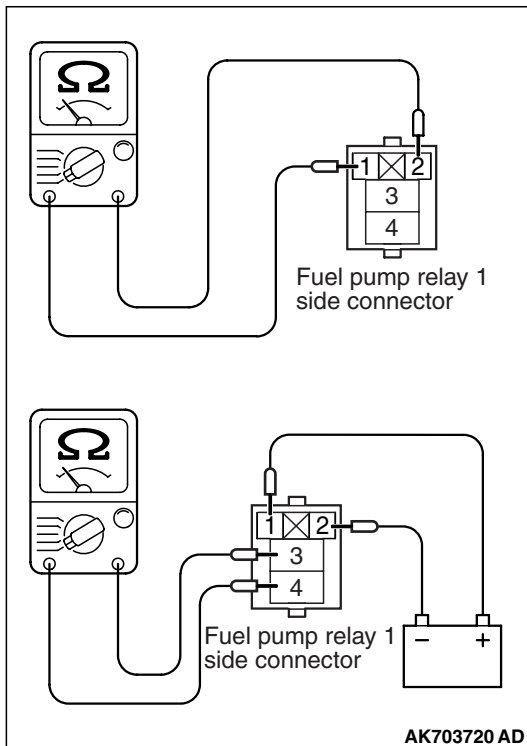

BATTERY VOLTAGE	TERMINAL NO. TO BE CONNECTED TO BATTERY	TERMINAL NO. TO BE CONDUCTED
Not supplied	–	1 –2
Supplied	1 –2	3 –4

Fuel pump relay 2

Inspect the fuel pump relay 2 for continuity in accordance with the chart shown below.

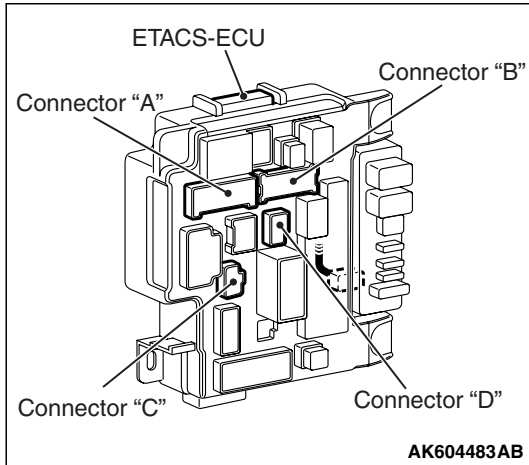

BATTERY VOLTAGE	TERMINAL NO. TO BE CONNECTED TO BATTERY	TERMINAL NO. TO BE CONDUCTED
Supplied	6 (Connector "A") -11 (Connector "B")	1 (Connector "C") - 1 (Connector "D")

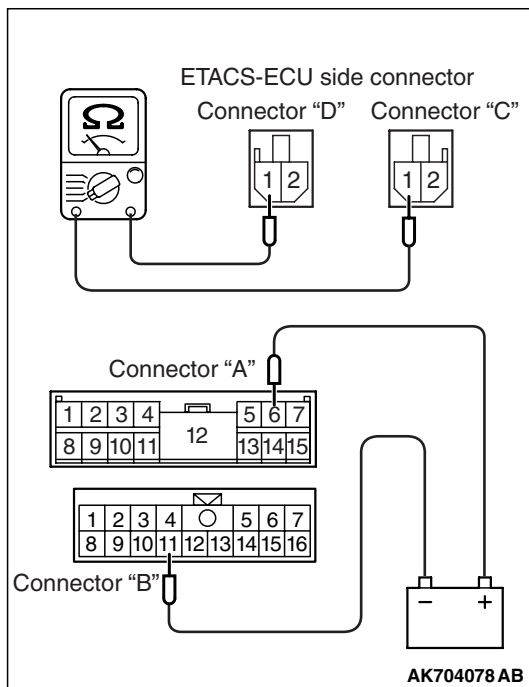

INJECTOR RELAY CONTINUITY CHECK

M1131054600264

Inspect the injector relay for continuity in accordance with the chart shown below.

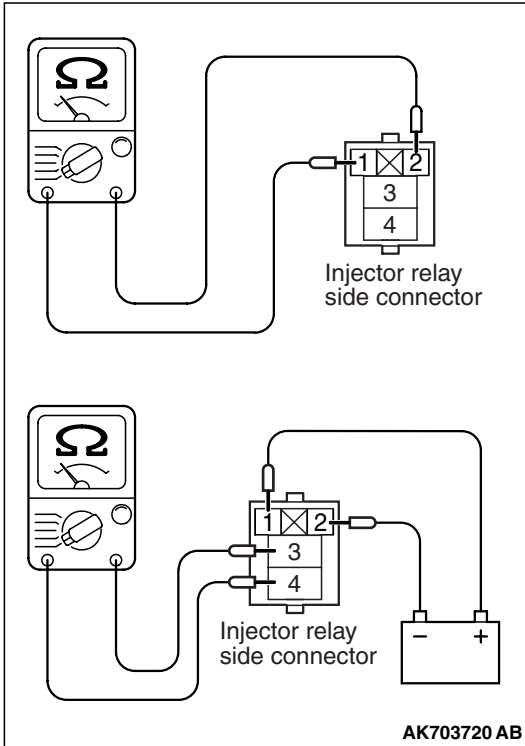

BATTERY VOLTAGE	TERMINAL NO. TO BE CONNECTED TO BATTERY	TERMINAL NO. TO BE CONDUCTED
Not supplied	–	1 –2
Supplied	1 –2	3 –4

THROTTLE ACTUATOR CONTROL MOTOR RELAY CONTINUITY CHECK

M1131054900027

Inspect the throttle actuator control motor relay for continuity in accordance with the chart shown below.

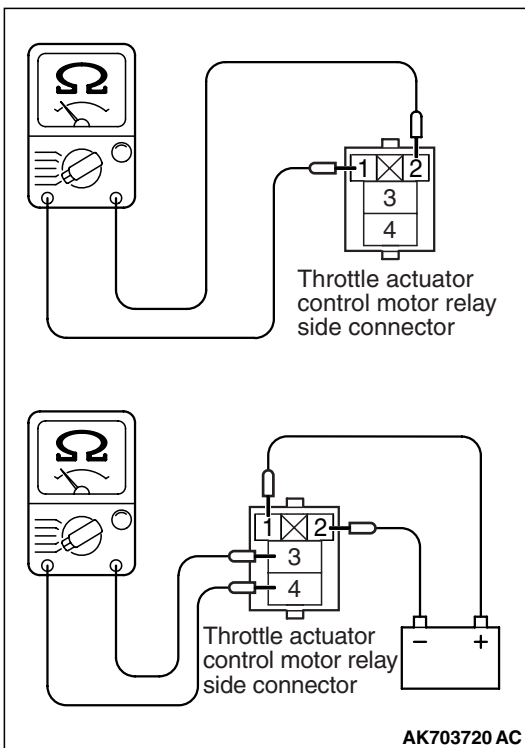

BATTERY VOLTAGE	TERMINAL NO. TO BE CONNECTED TO BATTERY	TERMINAL NO. TO BE CONDUCTED
Not supplied	–	1 –2
Supplied	1 –2	3 –4

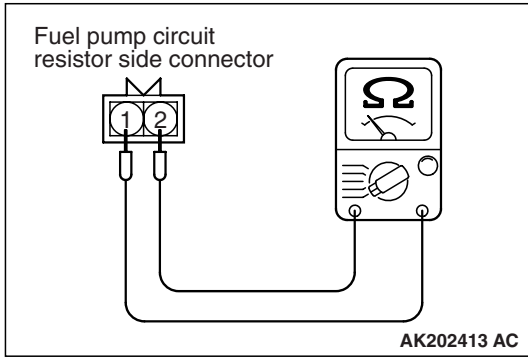

FUEL PUMP CIRCUIT RESISTOR CHECK

M1131055100013

1. Disconnect the fuel pump circuit resistor connector.
2. Measure the resistance between terminals.
Standard value: 0.45 –0.65 Ω [at 20° C (68° F)]
3. If the resistance is out of specification, replace the fuel pump circuit resistor.

INTAKE AIR TEMPERATURE SENSOR CHECK

M1131002801668

Intake air temperature sensor 1

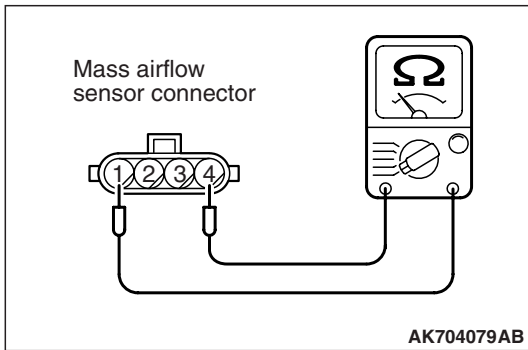

1. Disconnect the mass airflow sensor connector.
2. Measure the resistance between terminal No. 1 and terminal No. 4.

Standard value:

- 13 –17 kΩ [at -20° C (-4° F)]
- 5.4 –6.6 kΩ [at 0° C (32° F)]
- 2.3 –3.0 kΩ [at 20° C (68° F)]
- 1.0 –1.5 kΩ [at 40° C (104° F)]
- 0.56 –0.76 kΩ [at 60° C (140° F)]
- 0.31 –0.43 kΩ [at 80° C (176° F)]

3. If not within specifications, replace the mass airflow sensor.
4. Measure resistance while heating the sensor using a hair dryer.

Normal condition:

TEMPERATURE	RESISTANCE (kΩ)
Higher	Smaller

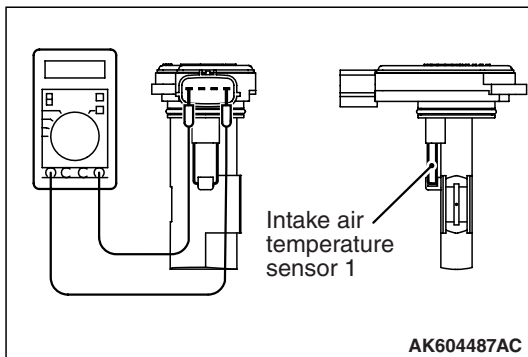

5. If the resistance does not decrease as heat increases, replace the mass airflow sensor.

Intake air temperature sensor 2

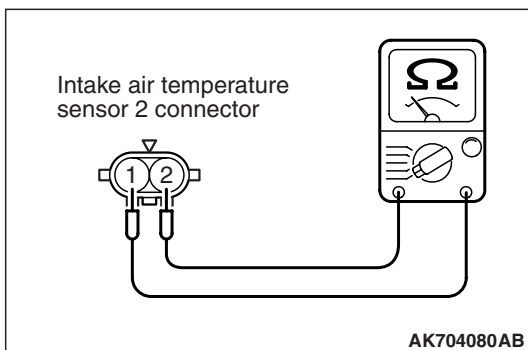

1. Disconnect the intake air temperature sensor 2 connector.
2. Measure the resistance between terminal No. 1 and terminal No. 2.

Standard value:

- 13 –18 kΩ [at -20° C (-4° F)]
- 5.1 –6.9 kΩ [at 0° C (32° F)]
- 2.0 –3.0 kΩ [at 20° C (68° F)]
- 0.9 –1.5 kΩ [at 40° C (104° F)]
- 0.40 –0.78 kΩ [at 60° C (140° F)]
- 0.23 –0.42 kΩ [at 80° C (176° F)]

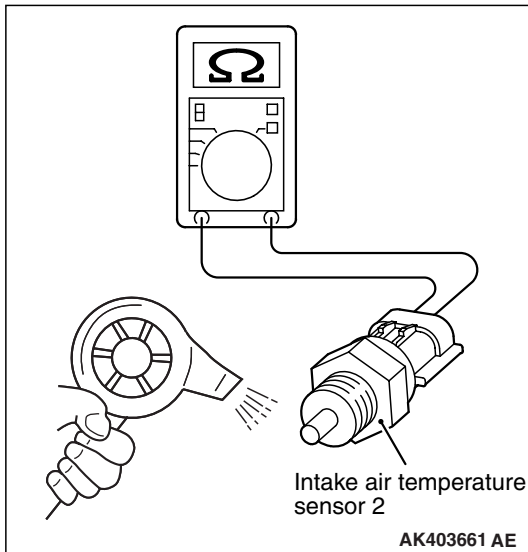

3. If not within specifications, replace the intake air temperature sensor 2.
4. Measure resistance while heating the sensor using a hair dryer.

Normal condition:

TEMPERATURE	RESISTANCE (kΩ)
Higher	Smaller

5. If the resistance does not decrease as heat increases, replace the intake air temperature sensor 2.

ENGINE COOLANT TEMPERATURE SENSOR CHECK

M1131003101673

Required Special Tools:

- MB992042: Engine coolant temperature sensor wrench

⚠ CAUTION

Be careful not to touch the connector (resin section) with the tool when removing and installing.

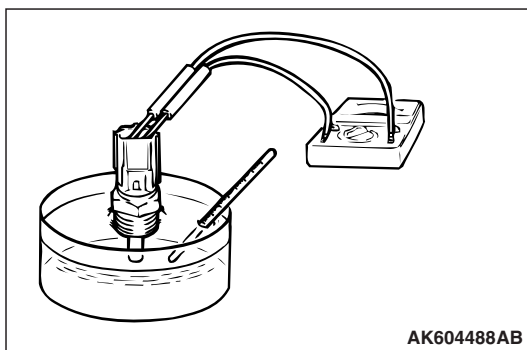
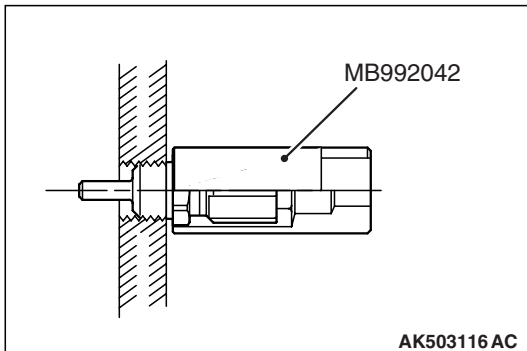

1. Drain engine coolant, then remove the engine coolant temperature sensor using the special tool MB992042 (engine coolant temperature sensor wrench).

2. With the temperature sensing portion of engine coolant temperature sensor immersed in hot water, check the resistance.

Standard value:

- 14 –17 kΩ [at -20° C (-4° F)]
- 5.1 –6.5 kΩ [at 0° C (32° F)]
- 2.1 –2.7 kΩ [at 20° C (68° F)]
- 0.9 –1.3 kΩ [at 40° C (104° F)]
- 0.48 –0.68 kΩ [at 60° C (140° F)]
- 0.26 –0.36 kΩ [at 80° C (176° F)]

3. If the resistance deviates from the standard value greatly, replace the sensor.

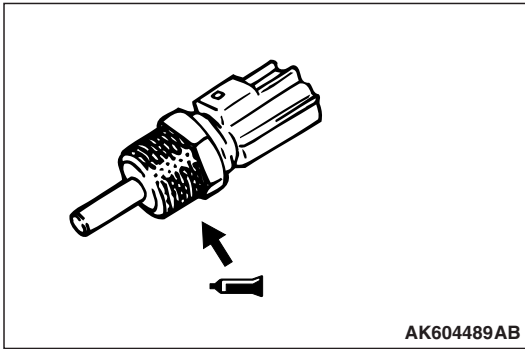

4. Apply LOCTITE 262, Three bond 1324N or equivalent to threaded portion.
5. With the special tool MB992042 (engine coolant temperature sensor wrench) tighten the engine coolant temperature sensor to the specified torque.

Tightening torque: 30 ± 9 N·m (22 ± 6 ft-lb)

HEATED OXYGEN SENSOR CHECK

M1131005002374

Required Special Tools:

- MB991958: Scan tool (M.U.T.-III Sub Assembly)
 - MB991824: V.C.I.
 - MB991827: USB Cable
 - MB991910: Main Harness A
- MB991658: Test Harness

Heated oxygen sensor (front)

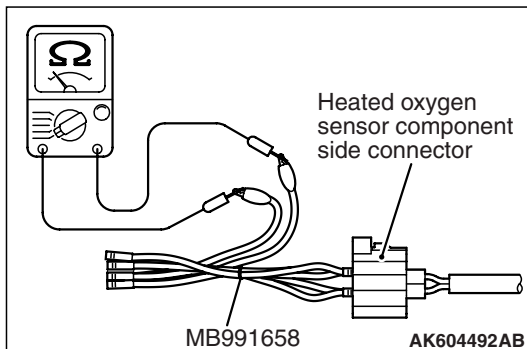

1. Disconnect the heated oxygen sensor connector and connect special tool MB991658 to the connector on the heated oxygen sensor side.
2. Measure the resistance between terminal No. 1 and terminal No. 2 on the heated oxygen sensor connector.

Standard value: 4.5 – 8.0 Ω [at 20 °C (68° F)]

3. If the resistance deviates from standard value, replace the heated oxygen sensor.
4. Warm up the engine until engine coolant is 80° C (176° F) or higher.
5. Rev the engine for 5 minutes or more with the engine speed of 2,000 r/min.
6. Connect a digital voltage meter between terminal No. 3 and terminal No. 4.

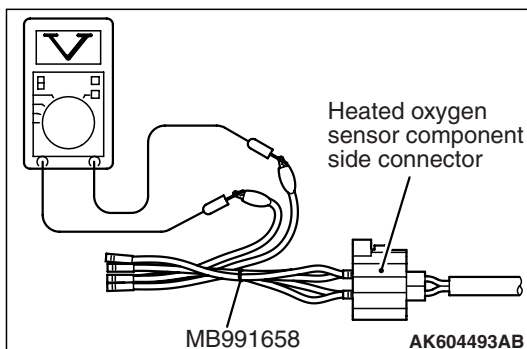

7. While repeatedly revving the engine, measure the heated oxygen sensor output voltage.

Standard value:

ENGINE	HEATED OXYGEN SENSOR OUTPUT VOLTAGE	REMARKS
When revving engine	0.6 –1.0 V	If you make the air/fuel ratio rich by revving the engine repeatedly, a normal heated oxygen sensor will output a voltage of 0.6 –1.0 V.

⚠ CAUTION

- Be very careful when connecting the jumper wire; incorrect connection can damage the oxygen sensor.
- Be careful the heater is broken when voltage of beyond 8V is applied to the oxygen sensor heater.

NOTE: If the temperature of sensing area does not reach the high temperature [of approximately 400 °C (752 °F) or more] even though the oxygen sensor is normal, the output voltage would be possibly low in spite of the rich air-fuel ratio. Therefore, if the output voltage is low, use a jumper wire to connect terminal No. 1 and terminal No. 2 of the oxygen sensor with a (+) terminal and (-) terminal of 8 V power supply respectively, then check again.

8. If the output voltage is not within the standard value, replace the heated oxygen sensor.

NOTE: For removal and installation of the heated oxygen sensor, refer to GROUP 15, Exhaust Pipe and Main Muffler – Removal and installation P.15-24.

Heated oxygen sensor (rear)

1. Disconnect the heated oxygen sensor connector and connect special tool MB991658 to the connector on the heated oxygen sensor side.
2. Measure the resistance between terminal No. 1 and terminal No. 2 on the heated oxygen sensor connector.

Standard value: 4.5 –8.0 Ω [at 20 °C (68 °F)]

3. If the resistance deviates from standard value, replace the heated oxygen sensor.
4. Warm up the engine until engine coolant is 80° C (176° F) or higher.
5. Drive at 50 km/h (31 mph) or more for 10 minutes.

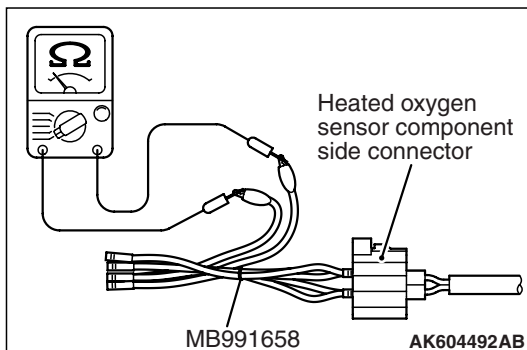

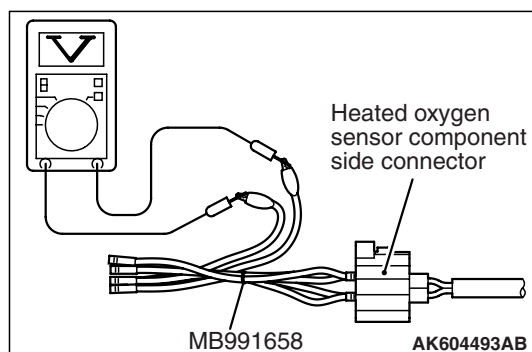

6. Connect a digital voltage meter between terminal No. 3 and terminal No. 4.
7. Measure the output voltage of the heated oxygen sensor under the following driving.
 - Transaxle: 2nd
 - Drive with wide open throttle
 - Engine: 3,500 r/min or more

Standard value:

HEATED OXYGEN SENSOR OUTPUT VOLTAGE	REMARKS
0.6 –1.0 V	High load operation makes air/fuel ratio richer and normal heated oxygen sensor also can output voltage of 0.6 –1.0 V.

NOTE: If the temperature of sensing area does not reach the high temperature [of approximately 400°C (752°F) or more] even though the oxygen sensor is normal, the output voltage would be possibly low in spite of the rich air-fuel ratio.

NOTE: When the vehicle is driven with high loads, the temperature of the sensing area of the oxygen sensor is sufficiently high. Thus, it is not necessary to apply the voltage to the heater.

8. If the output voltage is not within the standard value, replace the heated oxygen sensor.

NOTE: For removal and installation of the heated oxygen sensor, refer to GROUP 15, Exhaust Pipe and Main Muffler – Removal and installation P.15-24.

INJECTOR CHECK

M1131005202022

<Checking the Operation Sound>

Using a stethoscope or long blade screwdriver, check the operation sound ("tick-tick-tick") of injectors during idling or during cranking. Check that as the engine speed increases, the frequency of the operating sound also increases.

1. If the injector you are checking is not operating, you may hear the operating sound of the other injectors.
2. If no operating sound is heard from the injector that is being checked, check the injector drive circuit. If there is nothing wrong with the circuit, a defective injector or engine control module (ECM) is suspected.

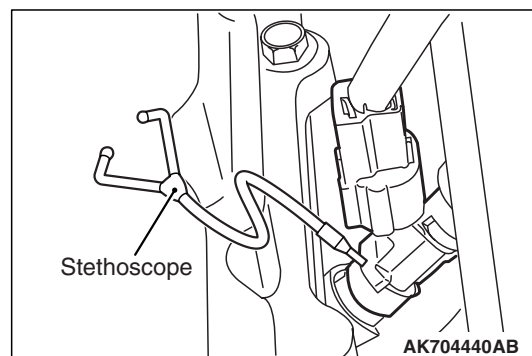

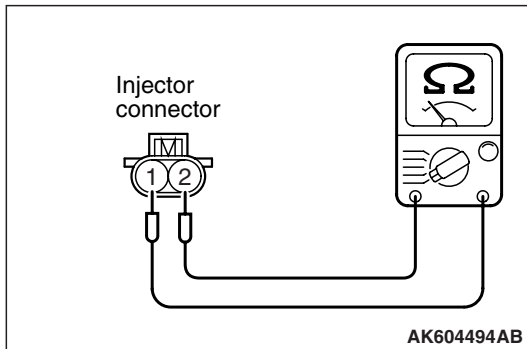

<Checking the Coil Resistance>

1. Disconnect the injector connector.
2. Measure the resistance between terminal No. 1 and terminal No. 2.

Standard value: 10.5 –13.5 Ω [at 20° C (68° F)]

3. If not within specification, replace the injector.
4. Connect the injector connector.

THROTTLE ACTUATOR CONTROL MOTOR CHECK

M1131051000876

<Operation Inspection>

⚠ WARNING

When checking the throttle valve operation, never insert fingers into the throttle valve. The extremely strong power of the throttle valve motor might trap and injure fingers.

1. Remove the air intake hose from the throttle body.
2. Set the ignition switch to the "ON" position.
3. Operate the accelerator pedal and confirm that the throttle valve is opening and closing accordingly.

<Checking the Terminal Resistance>

⚠ WARNING

If the throttle valve is operated in service, a finger might be injured as the result of being caught by the throttle valve. Make sure that the ignition switch is surely in "LOCK" (OFF) position before the service in order that the throttle valve cannot be operated.

1. Disconnect the electronic-controlled throttle valve connector.
2. Measure the resistance between terminal No. 1 and terminal No. 2.

Standard value: 0.3 –80 Ω [at 20° C (68° F)]

NOTE: *If the measured resistance deviates from the standard value, fully open the throttle valve with your finger more than five times, then check the result again. If the throttle valve control servo is not used for an extended period of time, the resistance may be increased as a result of internal forming of oxide film. Therefore, it means that the oxide film can be removed through a self cleaning capability of the throttle valve control servo, if forcibly moved.*

3. If the resistance is outside the standard value, replace the throttle body assembly.

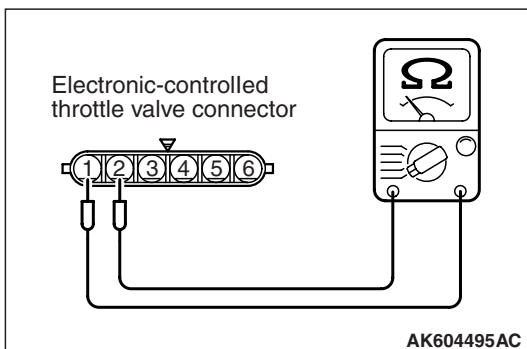

ENGINE OIL CONTROL VALVE CHECK**Required Special Tools:**

- MB991658: Test Harness

Intake engine oil control valve**<Checking the Operation Sound>**

1. Disconnect the intake engine oil control valve connector.

⚠ CAUTION

To prevent the coil from burning, keep the duration of the voltage application as short as possible.

2. Check that the operation sound of the intake engine oil control valve can be heard when the positive battery voltage is supplied to the intake engine oil control valve. (Use the special tool MB991658 to connect terminal No. 2 of the intake engine oil control valve connector to the positive battery terminal and terminal No. 1 to the negative battery terminal.)
3. If the operation sound cannot be heard, replace the intake engine oil control valve.

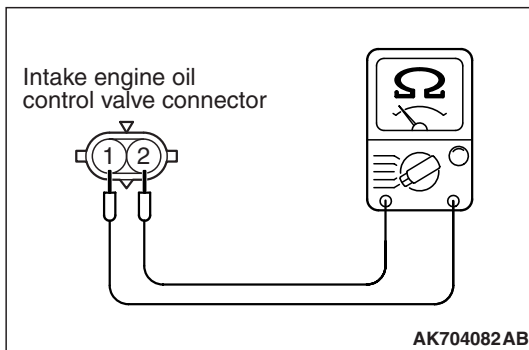
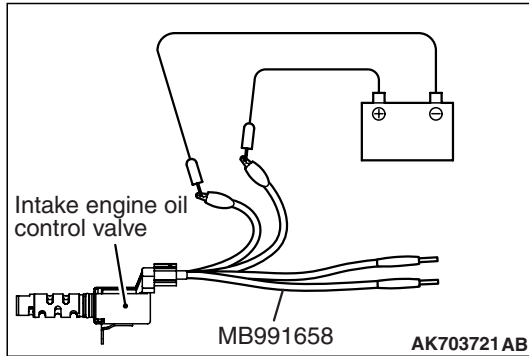
**<Checking the Coil Resistance>**

1. Disconnect the intake engine oil control valve connector.
2. Measure resistance between terminal No. 1 and terminal No. 2 of the connector at the intake engine oil control valve side.

Standard value: 6.9 –7.9 Ω [at 20° C (68° F)]

3. If resistance is not within the standard value, replace the intake engine oil control valve.

Exhaust engine oil control valve

<Checking the Operation Sound>

1. Disconnect the exhaust engine oil control valve connector.

⚠ CAUTION

To prevent the coil from burning, keep the duration of the voltage application as short as possible.

2. Check that the operation sound of the exhaust engine oil control valve can be heard when the positive battery voltage is supplied to the exhaust engine oil control valve. (Use the special tool MB991658 to connect terminal No. 2 of the exhaust engine oil control valve connector to the positive battery terminal and terminal No. 1 to the negative battery terminal.)
3. If the operation sound cannot be heard, replace the exhaust engine oil control valve.

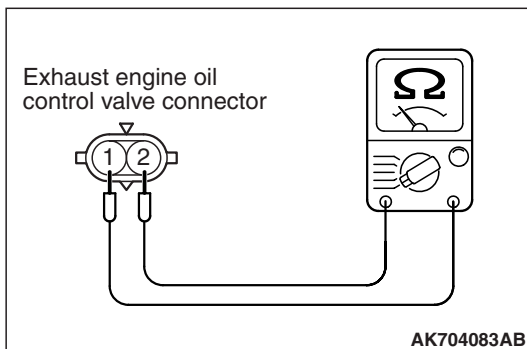
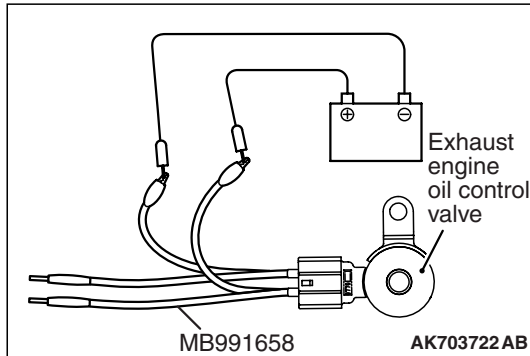

<Checking the Coil Resistance>

1. Disconnect the exhaust engine oil control valve connector.
2. Measure resistance between terminal No. 1 and terminal No. 2 of the connector at the exhaust engine oil control valve side.

Standard value: 6.9 –7.9 Ω [at 20° C (68° F)]

3. If resistance is not within the standard value, replace the exhaust engine oil control valve.

EVAPORATIVE EMISSION VENTILATION SOLENOID CHECK

M1131012800439

Refer to GROUP 17, Emission Control –Evaporative Emission Canister and Fuel Tank Pressure Relief Valve –Inspection [P.17-80](#).

EVAPORATIVE EMISSION PURGE SOLENOID CHECK

M1131005600507

Refer to GROUP 17, Emission Control –Evaporative Emission System –Evaporative Emission Purge Solenoid Check [P.17-77](#).

INJECTOR

REMOVAL AND INSTALLATION

M1131007102560

CAUTION

When the fuel injector is replaced, initialize the learned value using scan tool (Refer to GROUP 00, Precautions before Service –and Initialization Procedure of MFI Engine Learned Value P.00-31).

Pre-removal operation

- Fuel Pump Connector Disconnection (How to Reduce Pressurized Fuel Lines) (Refer to P.13A-901).
- Engine Upper Cover Removal (Refer to GROUP 16, Ignition System –Ignition Coil P.16-39).
- Charge Air Cooler Intake Hose A, B and Charge Air Cooler Intake Pipe A Removal (Refer to GROUP 15, Charge Air Cooler P.15-15).
- Air Cleaner Assembly Removal (Refer to GROUP 15, Air Cleaner P.15-10).

Post-installation operation

- Air Cleaner Assembly Installation (Refer to GROUP 15, Air Cleaner P.15-10).
- Charge Air Cooler Intake Hose A, B and Charge Air Cooler Intake Pipe A Installation (Refer to GROUP 15, Charge Air Cooler P.15-15).
- Fuel Leak Check
- Engine Upper Cover Installation (Refer to GROUP 16, Ignition System –Ignition Coil P.16-39).

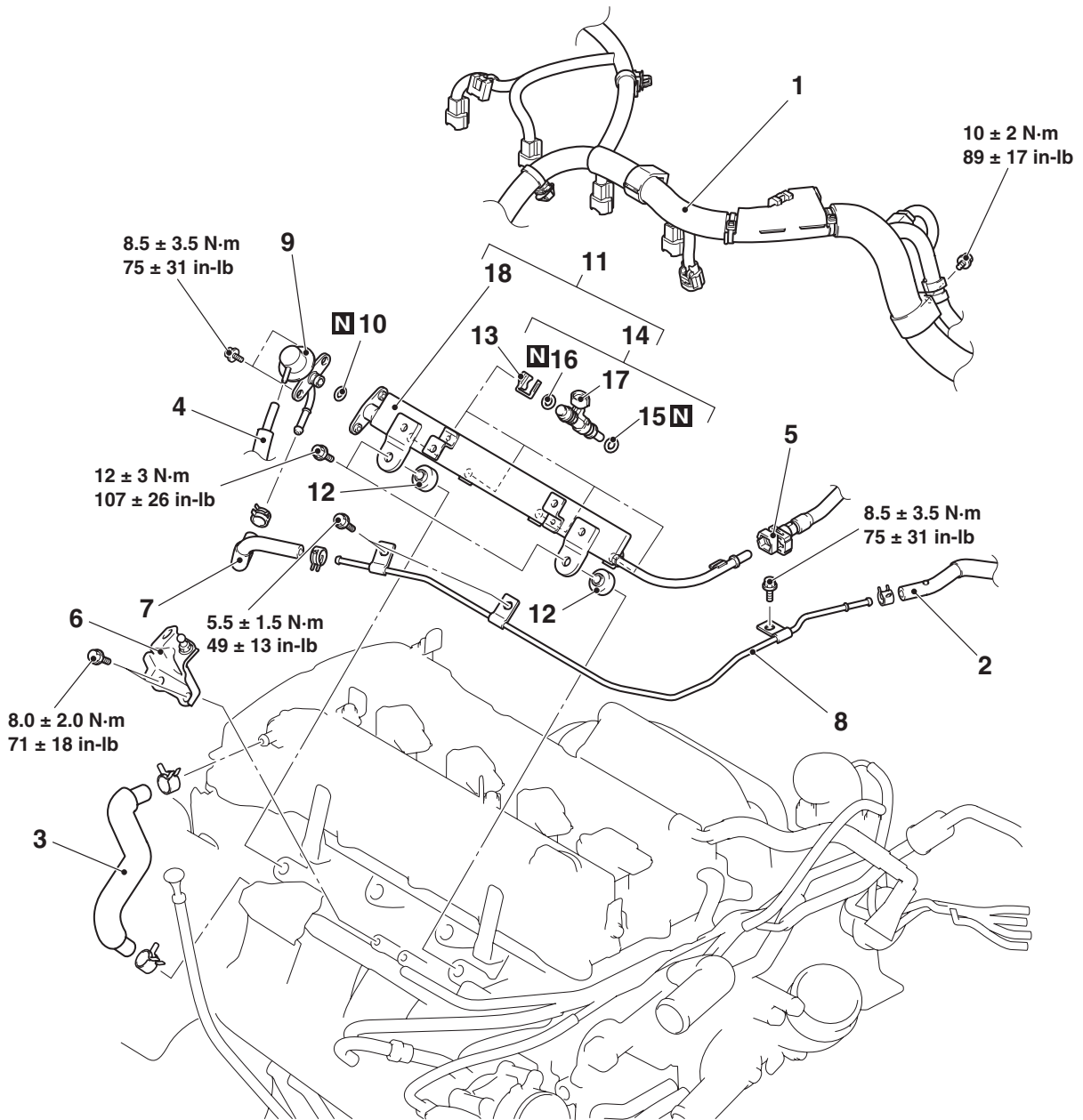

AC704329AC

Removal steps

1. Control wiring harness connection
2. Fuel return hose connection
3. PCV hose
4. Emission control equipment hose connection
5. Fuel high-pressure hose connection
6. Engine upper cover bracket rear
7. Fuel injector hose
8. Fuel injector return pipe

Removal steps (Continued)

9. MFI fuel rail pressure regulator
10. O-ring
11. Fuel rail and fuel injector assembly
12. Fuel rail insulator
13. Fuel injector support
14. Fuel injector assembly
15. O-ring
16. O-ring
17. Fuel injector
18. Fuel rail

<<A>> >>E<<

>>D<<

>>C<<

>>B<<

>>A<<

Required Special Tool:

- MB992106: O-ring Installer

REMOVAL SERVICE POINT

<<A>> FUEL HIGH-PRESSURE HOSE DISCONNECTION

1. Follow the steps below to unlock the fuel high-pressure hose connector.

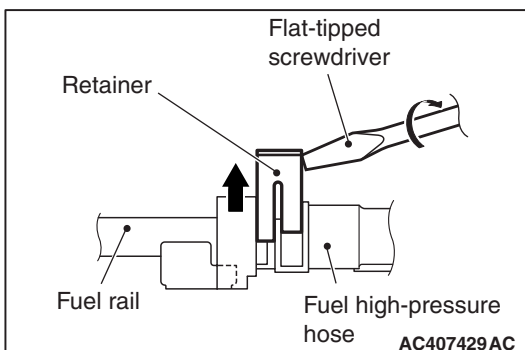
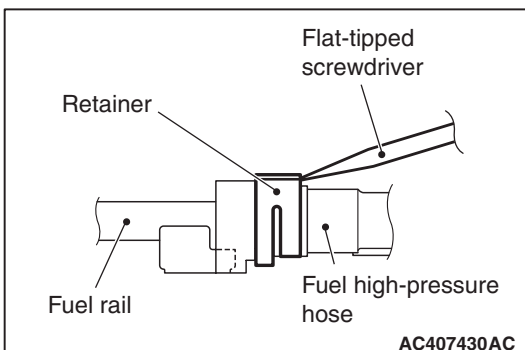
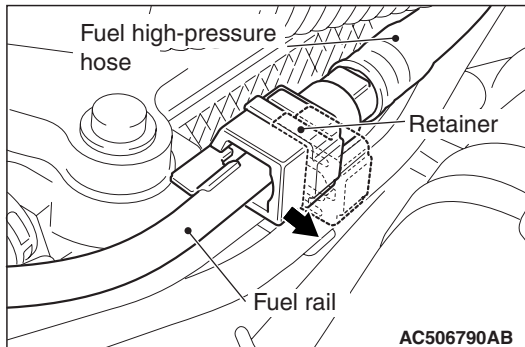

- (1) Insert a flat-tipped screwdriver [6 mm (0.24 inch) wide and 1 mm (0.04inch) thick] into the retainer of the fuel high-pressure hose connector.

⚠ CAUTION

When pushing up the retainer of the fuel high-pressure hose connector, pay attention to avoid damage to the retainer.

- (2) Turn the flat-tipped screwdriver inserted into the retainer by 90 degrees to push up the retainer and unlock the fuel high-pressure hose connector.
2. Remove the fuel high-pressure hose.

INSTALLATION SERVICE POINTS

>>A<< O-RING INSTALLATION

1. Apply a small amount of new engine oil to the O-ring.
2. While turning the fuel injector to right and left, install the O-ring to the fuel injector with care to avoid damage to the O-ring.

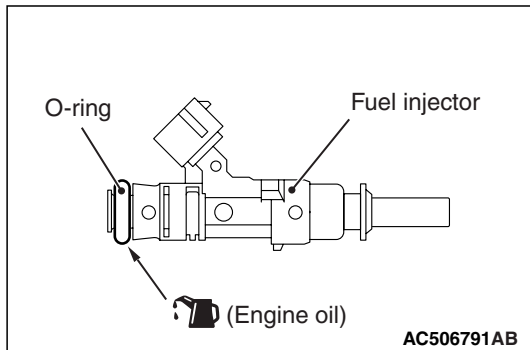

>>B<< O-RING INSTALLATION

1. Apply a small amount of new engine oil to the O-ring.
2. Using special tool MB992106, install the o-ring onto the fuel injector paying attention to avoid damage to the O-ring.

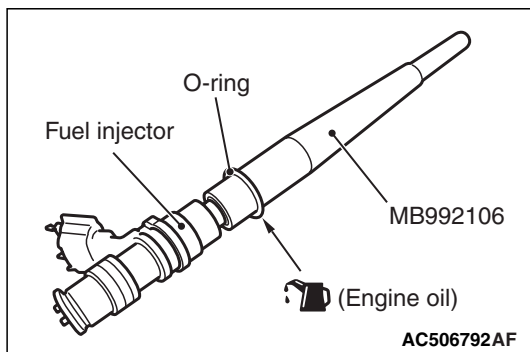
>>C<< FUEL INJECTOR ASSEMBLY
INSTALLATION**⚠ CAUTION**

When applying the engine oil, make sure not to allow the engine oil to enter the fuel rail inside.

1. Apply a small amount of new engine oil to the O-ring.
2. Turning the fuel injector assembly to right and left, install it to the fuel rail with care not to damage the O-ring. After the installation, check for its smooth rotation. At this time, check that the projection of the fuel injector assembly is in the center.
3. If the rotation is not smooth, the O-ring may be caught. Remove the fuel injector assembly and check the O-ring for damage. After this, re-insert it to the fuel rail and check for its smooth rotation.

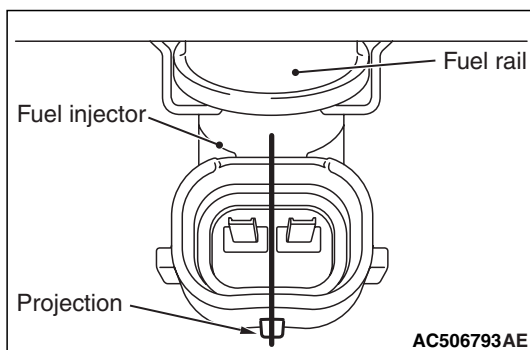

>>D<< FUEL INJECTOR SUPPORT INSTALLATION

Install the fuel injector support to the fuel injector groove and fuel rail brim, and fix the fuel injector assembly and fuel rail.

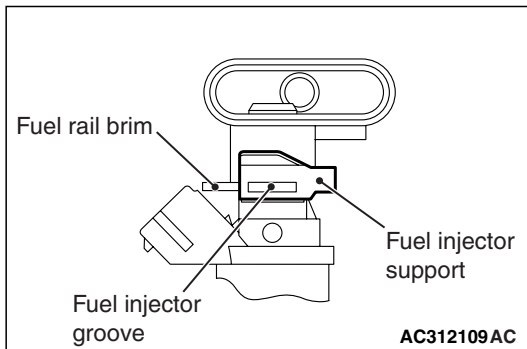

>>E<< FUEL HIGH-PRESSURE HOSE CONNECTION

⚠ CAUTION

- When pushing in the retainer of the fuel high-pressure hose connector, pay attention to avoid damage to the retainer.
- After the installation of the fuel high-pressure hose, slightly pull the fuel high-pressure hose to check that it is connected securely. At this time, also check that there is approximately 1 mm (0.04inch) play.

1. Securely insert the fuel rail stopper into the fuel high-pressure hose connector groove to install the fuel high-pressure hose to the fuel rail.
2. Push in the retainer of the fuel high-pressure hose connector to lock the fuel high-pressure hose and fuel rail.

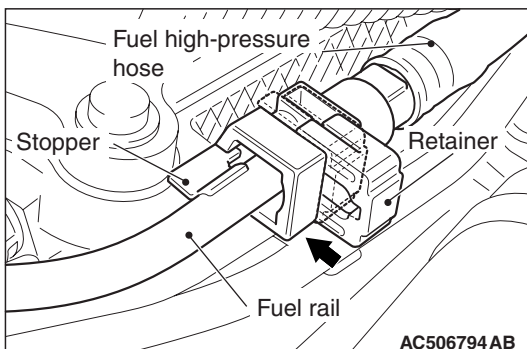

THROTTLE BODY ASSEMBLY

REMOVAL AND INSTALLATION

M1131007702227

CAUTION

- When the throttle body assembly is replaced, initialize the learned value using scan tool (Refer to GROUP 00, Precautions before Service –and Initialization Procedure of MFI Engine Learned Value P.00-31).
- Never loosen the screw fixing the throttle body assembly resin cover. If the screw is loosened, the sensor incorporated in the resin cover is misaligned and the throttle body assembly does not work normally.

<p>Pre-removal operation</p> <ul style="list-style-type: none"> • Engine Coolant Draining (Refer to GROUP 14, On-vehicle Service –Engine Coolant Replacement P.14-17). • Air Cleaner Body Removal (Refer to GROUP 15, Air Cleaner P.15-10). • Charge Air Cooler Outlet Hose E Removal (Refer to GROUP 15, Charge Air Cooler P.15-10). 	<p>Post-installation operation</p> <ul style="list-style-type: none"> • Charge Air Cooler Outlet Hose E Installation (Refer to GROUP 15, Charge Air Cooler P.15-10). • Air Cleaner Body Installation (Refer to GROUP 15, Air Cleaner P.15-10). • Engine Coolant Refilling (Refer to GROUP 14, On-vehicle Service –Engine Coolant Replacement P.14-17).
---	--

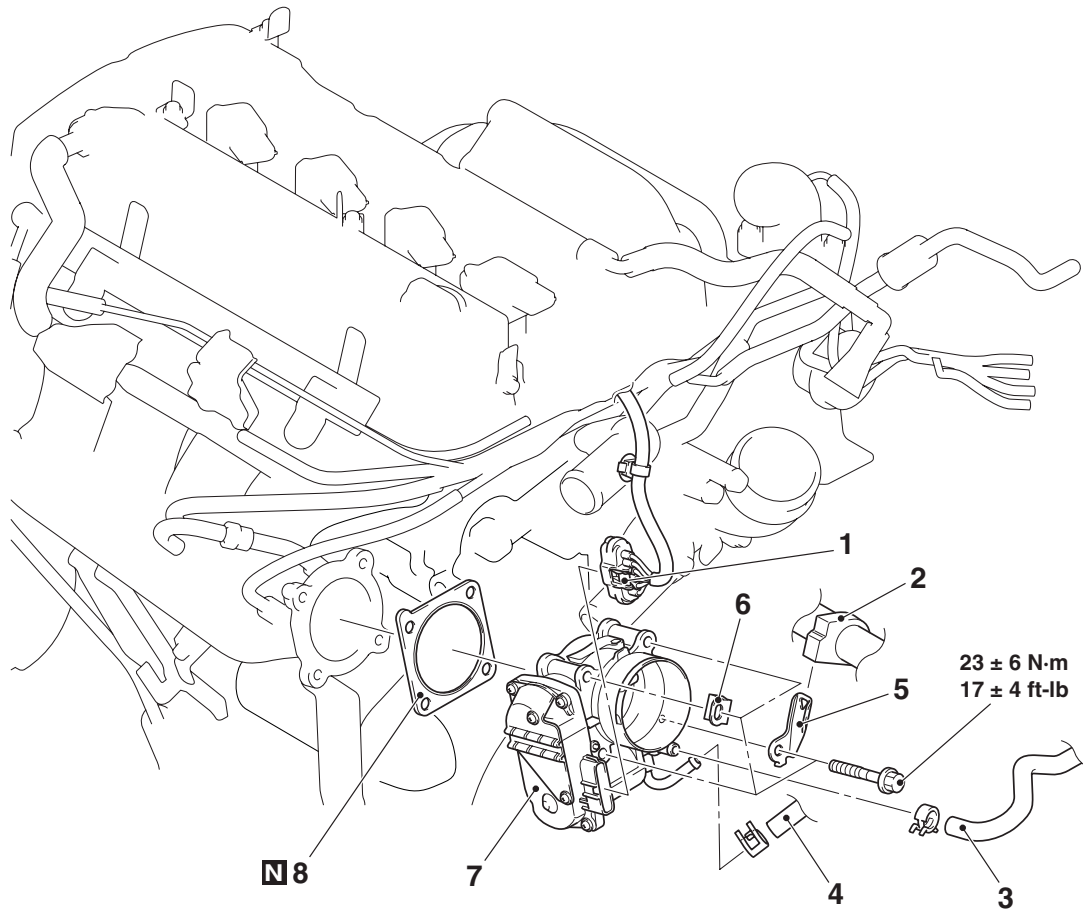

AC704284 AC

- | | | |
|---|---------------------------------|---|
| <p>>>B<<</p> <p>Removal steps</p> <ul style="list-style-type: none"> • Initialization operation (only at installation) 1. Electronic-controlled throttle valve connector connection 2. Battery wiring harness clamp 3. Cooling water line hose connection | <p>>>A<<</p> | <p>Removal steps (Continued)</p> <ul style="list-style-type: none"> 4. Cooling water line hose connection 5. Harness bracket 6. Harness bracket 7. Throttle body assembly 8. Throttle body gasket |
|---|---------------------------------|---|

INSTALLATION SERVICE POINTS

>>A<< THROTTLE BODY GASKET INSTALLATION

Install the throttle body gasket as its projection is in the direction shown.

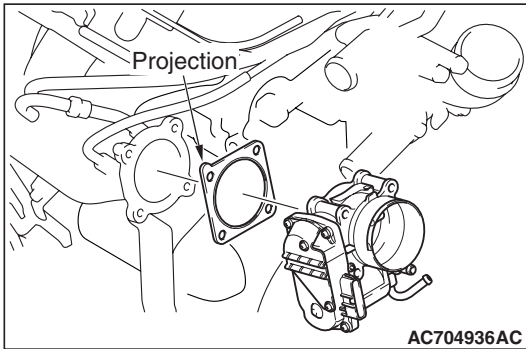

>>B<< INITIALIZATION OPERATION

Turn the ignition switch to the "ON" and then to "LOCK" (OFF) position and hold it for at least 10 seconds.

ENGINE CONTROL RESISTOR

REMOVAL AND INSTALLATION

M1131026000027

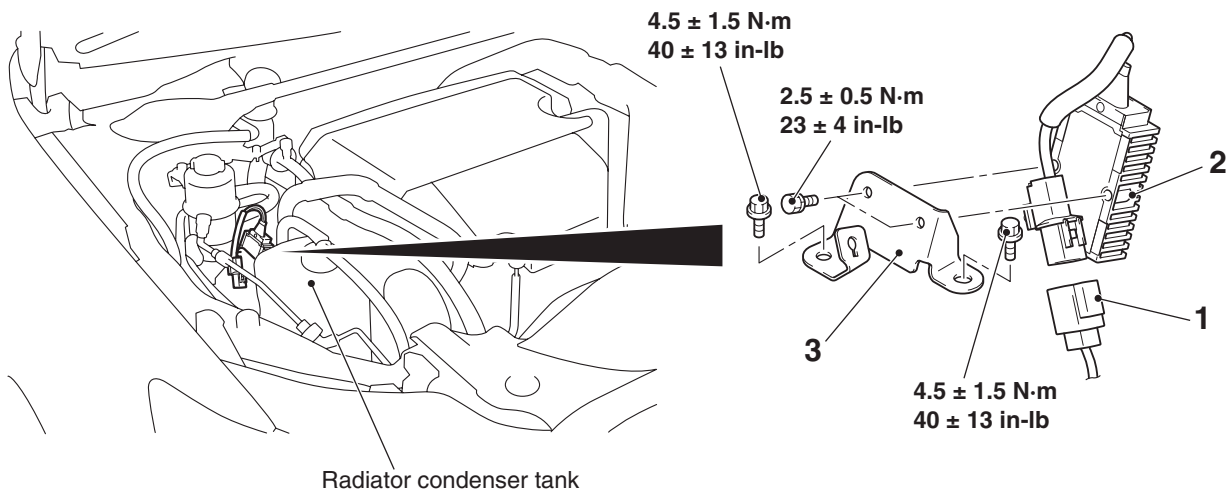

Radiator condenser tank

AC704791AC

Removal steps

1. Fuel pump resistor connector connection

Removal steps (Continued)

2. Fuel pump resistor
3. Relay bracket

ENGINE CONTROL MODULE (ECM)

REMOVAL AND INSTALLATION

M1131033800810

⚠ CAUTION

- When replacing the engine control module (ECM), do not replace the immobilizer-ECU (WCM) or KOS-ECU at the same time with ECM. When replacing multiple ECUs, always replace only one ECU at a time and complete necessary ID registration using the scan tool. (Refer to GROUP 42B – Diagnosis, ID Code Registration Judgment Table P.42B-12.) <Vehicles with KOS> (Refer to GROUP 42C –Diagnosis, ID Code Registration Judgment Table P.42C-9.) <Vehicles with WCM>
- After the engine control module (ECM) replacement, idling speed may be unstable because the MFI engine learning is not completed. To make it stable, let the system learn the idling. (Refer to GROUP 00, Precautions Before Service –Learning Procedure for Idling in MFI Engine P.00-32.)
- After the engine control module (ECM) replacement, register a key code using the scan tool (Refer to GROUP 00 –Precautions Before Service, How to Perform Vehicle Identification Number (VIN) Writing P.00-27).
- When replacing the engine control module (ECM), be sure to use an engine control module (ECM) with which the vehicle identification number writing and coding are completed. If diagnostic trouble code No. P0630 vehicle identification number-related or No. P1676 variant coding-related is set in the engine control module (ECM), replace it with an engine control module (ECM) to which the same vehicle identification number has been entered and the same coding has been made.
- When the engine control module (ECM) is replaced, the initial learning value of timing chain elongation amount must be stored and written by using the scan tool (Refer to GROUP 00 –Precautions Before Service, Timing Chain Maintenance P.00-33).

Pre-removal and post-installation operation

- Air Cleaner Assembly Removal and Installation (Refer to GROUP 15, Air Cleaner P.15-10).

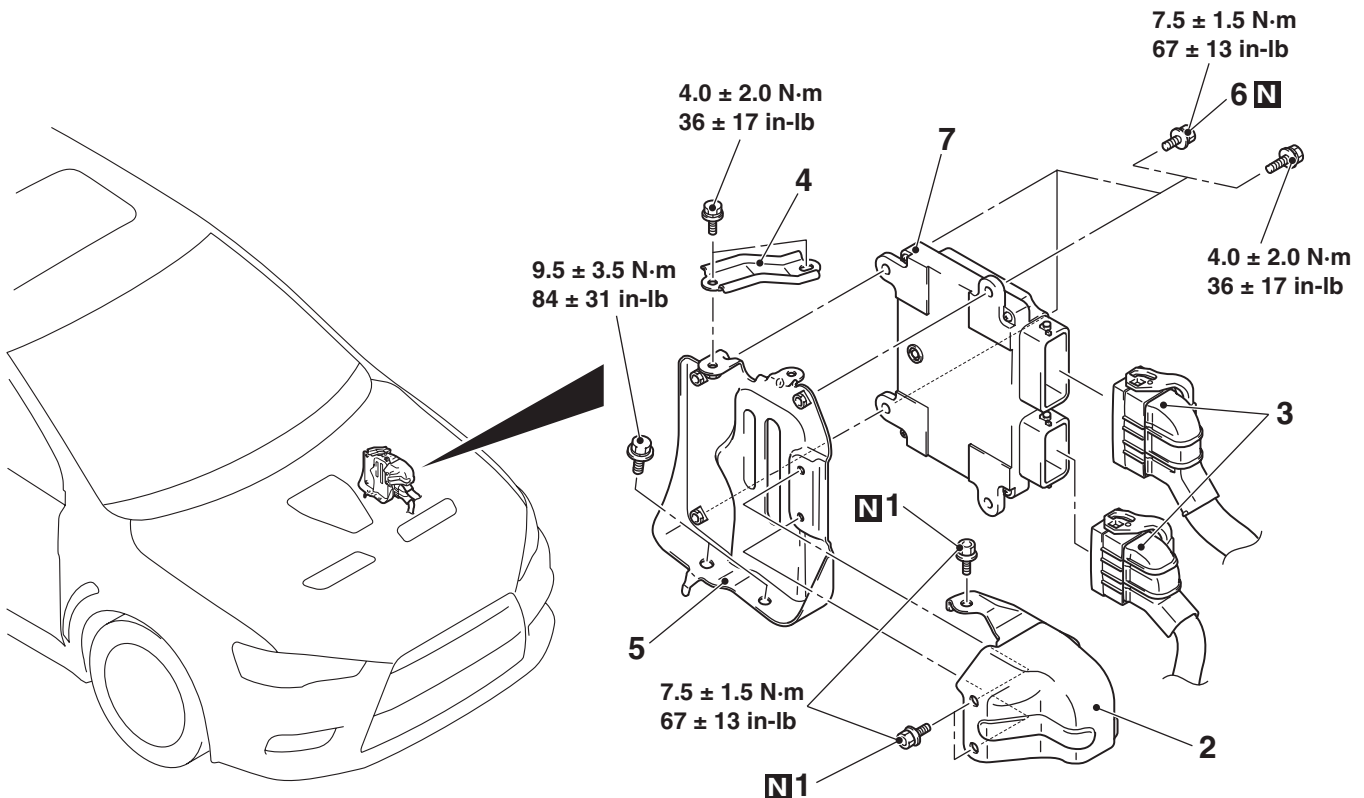

AC709020AB

- | | | | |
|-------|---|---|---|
| | Removal steps | | Removal steps (Continued) |
| >>B<< | • Initialization operation (only at installation) | | 3. Engine control module connector connection |
| <<A>> | >>A<< | 1. Break-off bolts <vehicles for Canada> | 4. Engine control modulator stay |
| | | 2. Control unit cover <vehicles for Canada> | 5. Engine control modulator bracket |
| | <<A>> | >>A<< | 6. Break-off bolts <vehicles for Canada> |
| | | | 7. Engine control module |

REMOVAL SERVICE POINT

<<A>> BREAK-OFF BOLTS REMOVAL <VEHICLES FOR CANADA>

1. Drill in the break-off bolt a hole deep enough for the tap to stand.
2. Remove the break-off bolt with a left-hand tap.

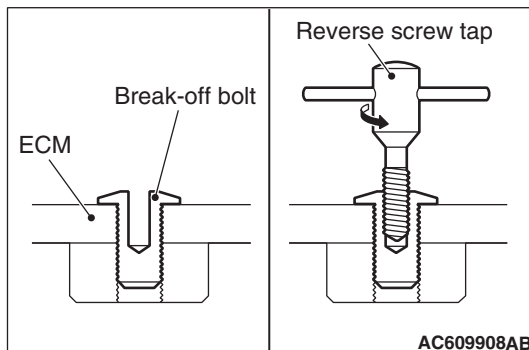

INSTALLATION SERVICE POINTS

>>A<< BREAK-OFF BOLTS INSTALLATION <VEHICLES FOR CANADA>

Tighten until the head of break-off bolt is broken off.

>>B<< INITIALIZATION OPERATION

Turn the ignition switch to the "ON" and then to "LOCK" (OFF) position and hold it for at least 10 seconds.

NOTES