

## GROUP 16

# ENGINE ELECTRICAL

## CONTENTS

<b>CHARGING SYSTEM</b> .....	<b>16-2</b>	<b>STARTER MOTOR ASSEMBLY</b> ..	16-27
<b>GENERAL INFORMATION</b> .....	16-2	REMOVAL AND INSTALLATION.....	16-27
GENERAL SPECIFICATIONS.....	16-3	INSPECTION .....	16-28
<b>SERVICE SPECIFICATIONS</b> .....	16-3	DISASSEMBLY AND ASSEMBLY.....	16-30
<b>CHARGING SYSTEM DIAGNOSIS</b>	16-3	INSPECTION .....	16-32
<b>SPECIAL TOOL</b> .....	16-6	<b>IGNITION SYSTEM</b> .....	<b>16-34</b>
<b>ON-VEHICLE SERVICE</b> .....	16-7	<b>GENERAL INFORMATION</b> .....	16-34
GENERATOR OUTPUT LINE VOLTAGE		GENERAL SPECIFICATIONS .....	16-35
DROP TEST .....	16-7	<b>SERVICE SPECIFICATIONS</b> .....	16-35
OUTPUT CURRENT TEST .....	16-8	<b>ON-VEHICLE SERVICE</b> .....	16-36
REGULATED VOLTAGE TEST.....	16-10	KNOCK CONTROL SYSTEM CHECK..	16-36
WAVE PATTERN CHECK USING AN		IGNITION COIL CHECK.....	16-36
OSCILLOSCOPE.....	16-11	SPARK PLUG TEST .....	16-37
<b>GENERATOR ASSEMBLY</b> .....	16-14	SPARK PLUG CHECK AND CLEANING	16-37
REMOVAL AND INSTALLATION .....	16-14	CAMSHAFT POSITION SENSOR CHECK	16-38
DISASSEMBLY AND ASSEMBLY.....	16-16	CRANKSHAFT POSITION SENSOR	
INSPECTION.....	16-20	CHECK.....	16-38
<b>STARTING SYSTEM</b> .....	<b>16-23</b>	<b>IGNITION COIL</b> .....	16-39
<b>GENERAL INFORMATION</b> .....	16-23	REMOVAL AND INSTALLATION.....	16-39
GENERAL SPECIFICATIONS.....	16-24	<b>CAMSHAFT POSITION SENSOR</b> .	16-40
<b>SERVICE SPECIFICATIONS</b> .....	16-24	REMOVAL AND INSTALLATION.....	16-40
<b>STARTING SYSTEM DIAGNOSIS</b>	16-24	<b>CRANKSHAFT POSITION SENSOR</b>	16-41
<b>ON-VEHICLE SERVICE</b> .....	16-26	REMOVAL AND INSTALLATION.....	16-41
STARTER RELAY CHECK .....	16-26	<b>KNOCK SENSOR</b> .....	16-42
		REMOVAL AND INSTALLATION.....	16-42

# CHARGING SYSTEM

## GENERAL INFORMATION

M1161000101291

The charging system charges the battery with the generator output to keep the battery charged at a constant level during varying electrical load.

## OPERATION

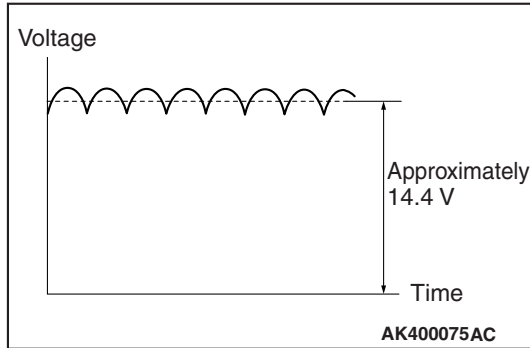

Rotation of the excited field coil generates AC voltage in the stator. This alternating current is rectified through diodes to DC voltage having a waveform shown in the illustration above. The average output voltage fluctuates slightly with the generator load condition.

When the ignition switch is turned on, current flows in the field coil and initial excitation of the field coil occurs.

When the stator coil begins to generate power after the engine is started, the field coil is excited by the output current of the stator coil.

The generator output voltage rises as the field current increases and it falls as the field current decreases. When the battery positive voltage (generator S terminal voltage) reaches a regulated voltage of approximately 14.4 V, the field current is cut off. When the battery positive voltage drops below the regulated voltage, the voltage regulator regulates the output voltage to a constant level by controlling the field current.

In addition, when the field current is constant, the generator output voltage rises as the engine speed increases.

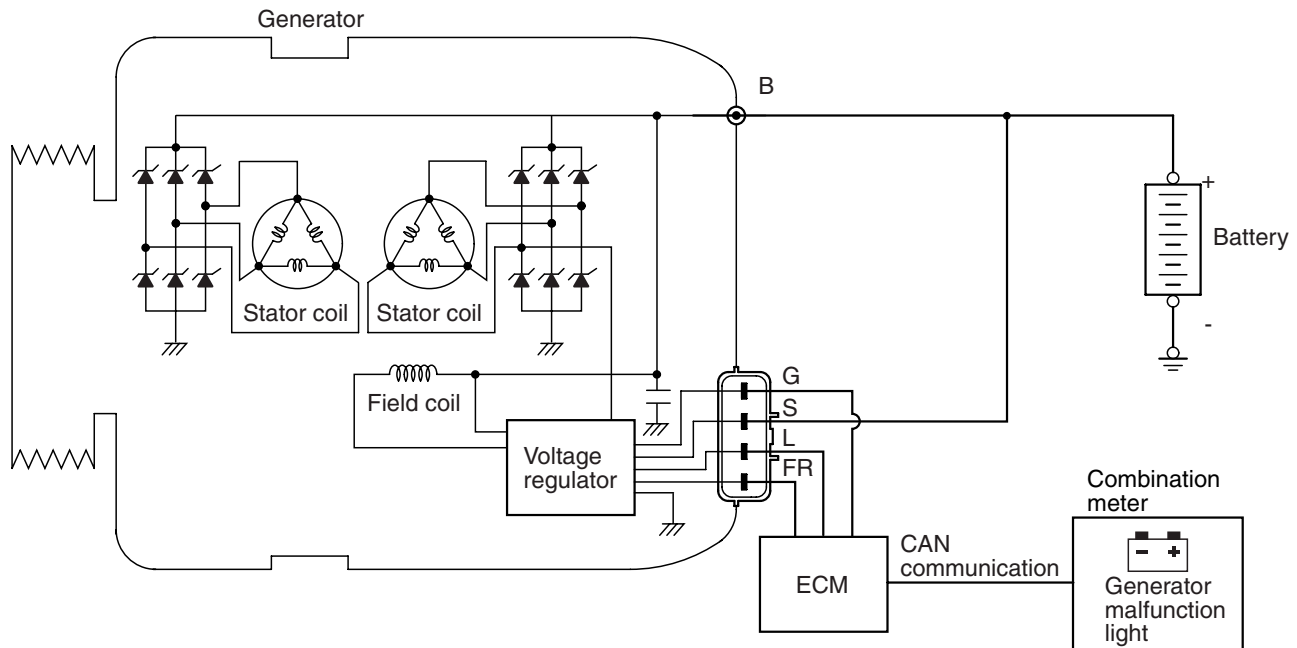

AK704219AB

**GENERAL SPECIFICATIONS**

M1161000200518

Item	Specification
Type	Positive battery positive voltage sensing
Identification number	A3TL0081
Part No.	1800A155
Rated output V/A	12/120
Voltage regulator	Electronic built-in type

**SERVICE SPECIFICATIONS**

M1161000301024

Item	Standard value	Limit
Regulated voltage (Ambient temperature at voltage regulator)	-20° C (-4° F)	14.2 –15.4
	20° C (68° F)	13.9 –14.9
	60° C (140° F)	13.4 –14.6
	80° C (176° F)	13.1 –14.5
Generator output line voltage drop (at 30 A) V	–	Maximum 0.3
Output current	–	70 % of normal output current
Field coil resistance Ω	Approximately 2 –5	–
Brush protrusion length mm (in)	–	Minimum 2 (0.08)

**CHARGING SYSTEM DIAGNOSIS**

M1161000700535

**TROUBLESHOOTING HINTS**

Generator malfunction light does not go on when the ignition switch is turned to ON, before the engine starts.

- Check the generator malfunction light.

Generator malfunction light does not switch off after the engine starts.

- Check the IC voltage regulator inside the generator.

Discharged or overcharged battery.

- Check the IC voltage regulator inside the generator.

**TROUBLESHOOTING GUIDE**

The charging system troubleshooting guide is shown in the following steps.

**STEP 1.**

**Q: Is the battery in good condition? (Refer to GROUP 54A, Chassis Electrical –Battery –On-vehicle Service – Battery Test P.54A-9.)**

**YES :** Go to Step 2.

**NO :** Charge or replace the battery.

---

**STEP 2.**

**Q: Is the generator drive belt in good condition? (Refer to GROUP 00, General –Maintenance Service –Drive Belts (For Generator, Power Steering Pump and Air Conditioning) (Check) P.00-66.)**

**YES :** Go to Step 3.

**NO :** Adjust the belt tension or replace the belt.

---

**STEP 3.**

**Q: Does the generator malfunction light come on when the ignition switch is turned on?**

**YES :** Go to Step 4.

**NO :** Check the ignition switch. (Refer to GROUP 54A, Chassis Electrical –Ignition Switch –Ignition Switch –Inspection P.54A-22).

Check the generator malfunction light and its related circuits.

Check the generator. (Refer to Charging System – Generator Assembly –Inspection P.16-20).

---

**STEP 4.**

**Q: Does the generator malfunction light go out after starting the engine?**

**YES :** Go to Step 5.

**NO :** Check the generator (Refer to Charging System – Generator Assembly –Inspection P.16-20.)

---

**STEP 5.**

**Q: Is an oscilloscope available?**

**YES :** Go to Step 6.

**NO :** Go to Step 7.

---

**STEP 6.**

**Q: Does the oscilloscope show a normal wave pattern? (Refer to Charging System –On-vehicle Service –Wave Pattern Check Using an Oscilloscope P.16-11.)**

**YES :** Go to Step 7.

**NO :** Check the generator. (Refer to Charging System – Generator Assembly –Inspection P.16-20.)

---

---

**STEP 7.**

- Engine: 2,500 r/min
- Headlight: ON (high beam)
- Voltage between generator terminal B and the positive battery terminal  
OK: 0.5 V or less
- Voltage between the negative battery terminal and generator body  
OK: 0.5 V or less

**Q: Are the generator output line and ground line in good condition?**

**YES :** Go to Step 8.

**NO :** Check the generator output line and ground line.

---

**STEP 8.**

**Q: Is the output current normal? (Refer to Charging System –On-vehicle Service –Output Current Test P.16-8.)**

**YES :** Go to Step 9.

**NO :** Check the generator (Refer to Charging System – Generator Assembly –Inspection P.16-20.)

---

**STEP 9.**

**Q: Is the regulated voltage normal? (Refer to Charging System –On-vehicle Service –Regulated Voltage Test P.16-10.)**

**YES :** Go to Step 10.

**NO :** Check the generator (Refer to Charging System – Generator Assembly –Inspection P.16-20.)

---

**STEP 10.**



**Q: Is the voltage drop in the generator output line normal?**

**YES :** Generator is normal. Check other systems.

**NO :** Check the output line.

SPECIAL TOOL

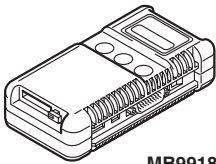
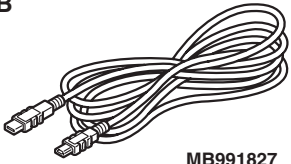
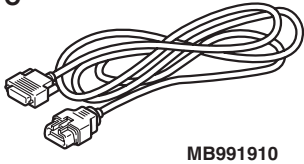
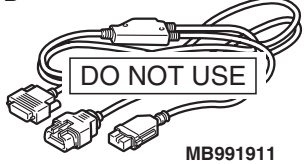
M116100600903

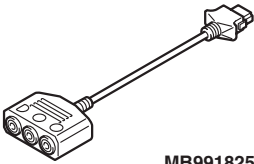
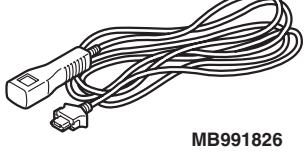
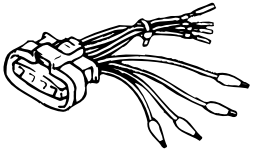
TOOL	TOOL NUMBER AND NAME	SUPERSESSION	APPLICATION
<p>A</p>  <p>MB991824</p> <p>B</p>  <p>MB991827</p> <p>C</p>  <p>MB991910</p> <p>D</p>  <p>MB991911</p> <p>E</p>  <p>MB991914</p> <p>F</p>  <p>MB991825</p> <p>G</p>  <p>MB991826 MB991958</p>	<p>MB991958 Scan tool (M.U.T.-III sub assembly) A: MB991824 Vehicle communication interface (V.C.I.)</p> <p>B: MB991827 M.U.T.-III USB cable</p> <p>C: MB991910 M.U.T.-III main harness A (Vehicles with CAN communication system)</p> <p>D: MB991911 M.U.T.-III main harness B (Vehicles without CAN communication system)</p> <p>E: MB991914 M.U.T.-III main harness C (for Daimler Chrysler models only)</p> <p>F: MB991825 M.U.T.-III measurement adapter</p> <p>G: MB991826 M.U.T.-III trigger harness</p>	<p>MB991824-KIT</p> <p><i>NOTE: G: MB991826 M.U.T.-III Trigger Harness is not necessary when pushing V.C.I. ENTER key.</i></p>	<p>Checking of engine speed</p> <p><b>CAUTION</b></p> <p><b>For vehicles with CAN communication, use M.U.T.-III main harness A to send simulated vehicle speed. If you connect M.U.T.-III main harness B instead, the CAN communication does not function correctly.</b></p>
	<p>MB991519 Generator harness connector</p>	<p>MIT530 Micrd 530 charging system tester.</p>	<p>Checking of generator ("S" terminal voltage)</p>

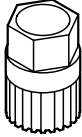
TOOL	TOOL NUMBER AND NAME	SUPERSESION	APPLICATION
 MB992226	MB992226 Serration socket	–	Removal and installation of alternator's one way clutch

## ON-VEHICLE SERVICE

### GENERATOR OUTPUT LINE VOLTAGE DROP TEST

M1161000901480

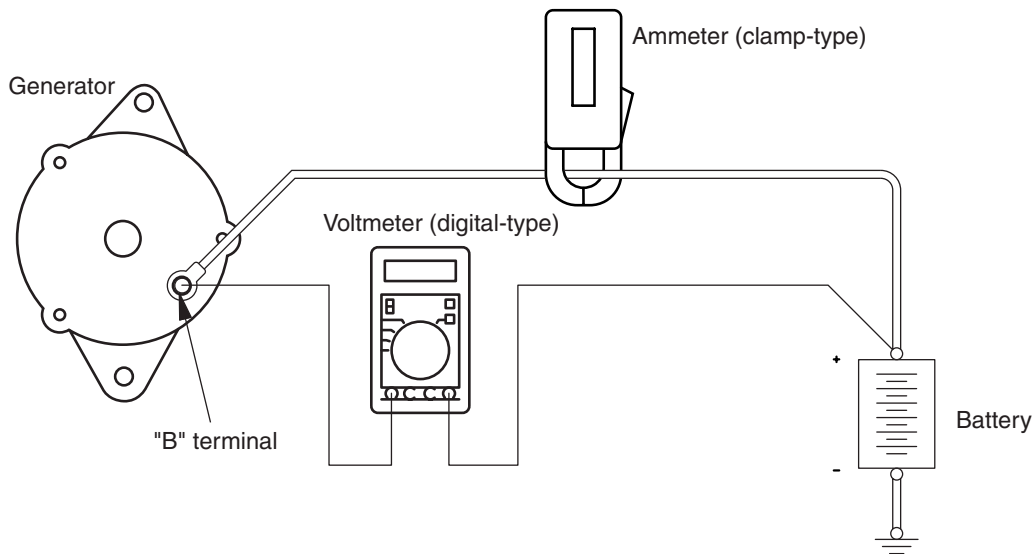

AK203361AG

#### Required Special Tool:

MB991958: Scan Tool (M.U.T.-III Sub Assembly)

- MB991824: V.C.I.
- MB991827: M.U.T.-III USB Cable
- MB991910: M.U.T.-III Main Harness A

This test determines whether the wiring from the generator "B" terminal to the positive battery terminal (including the fusible link) is in good condition or not:

#### **⚠ WARNING**

**Battery posts, terminals and related accessories contain lead and lead compounds. WASH HANDS AFTER HANDLING.**

1. Always be sure to check the following before the test.
  - Generator installation
  - Generator drive belt tension (Refer to GROUP 00, General –Maintenance Service –Drive Belts (For Generator, and Air Conditioning) (Check P.00-66.)
  - Fusible link

- Abnormal noise from the generator while the engine is running.

2. Turn the ignition switch to the "LOCK" (OFF) position.

3. Disconnect the negative battery cable.

4. Set a clamp-type DC test ammeter to the generator "B" terminal output wire.

*NOTE: Disconnecting the generator output wire and connecting the ammeter may not thoroughly diagnosis an output current drop problem because of an insufficient connection between terminal "B" and the output wire.*

5. Connect a digital-type voltmeter between the generator "B" terminal and the positive battery terminal. (Connect the positive lead of the voltmeter to the "B" terminal, and then connect the negative lead of the voltmeter to the positive battery cable.)

6. Reconnect the negative battery cable.

7. Connect an engine tachometer or scan tool MB991958.
8. Leave the hood open.
9. Start the engine.
10. With the engine running at 2,500 r/min, turn the headlamps and other lamps on and off to adjust the generator load so that the value displayed on the ammeter is slightly above 30 A.

Adjust the engine speed by gradually decreasing it until the value displayed on the ammeter is 30 A. Take a reading of the value displayed on the voltmeter at this time.

**Limit: maximum 0.3 V**

*NOTE: When the generator output is high and the value displayed on the ammeter does not decrease until 30 A, set the value to 40 A. Read the value displayed on the voltmeter at this time. When the value range is 40 A, the limit is maximum 0.4 V.*

11. If the value displayed on the voltmeter is above the limit value, there is probably a malfunction in the generator output wire. Check the wiring between the generator "B" terminal and the positive battery terminal (including fusible link).

If a terminal is not sufficiently tight or if the harness has become discolored due to overheating, repair and then test again.

12. After the test, run the engine at idle.
13. Turn off all lights and turn the ignition switch to the "LOCK" (OFF) position.

*NOTE: Vehicles for Canada, the headlight, tail-light, etc. remain lit even when the lighting switch is in "OFF" position.*

14. Disconnect the engine tachometer or scan tool MB991958.
15. Disconnect the negative battery cable.
16. Remove the ammeter and voltmeter.
17. Connect the negative battery cable.

## OUTPUT CURRENT TEST

M1161001001587

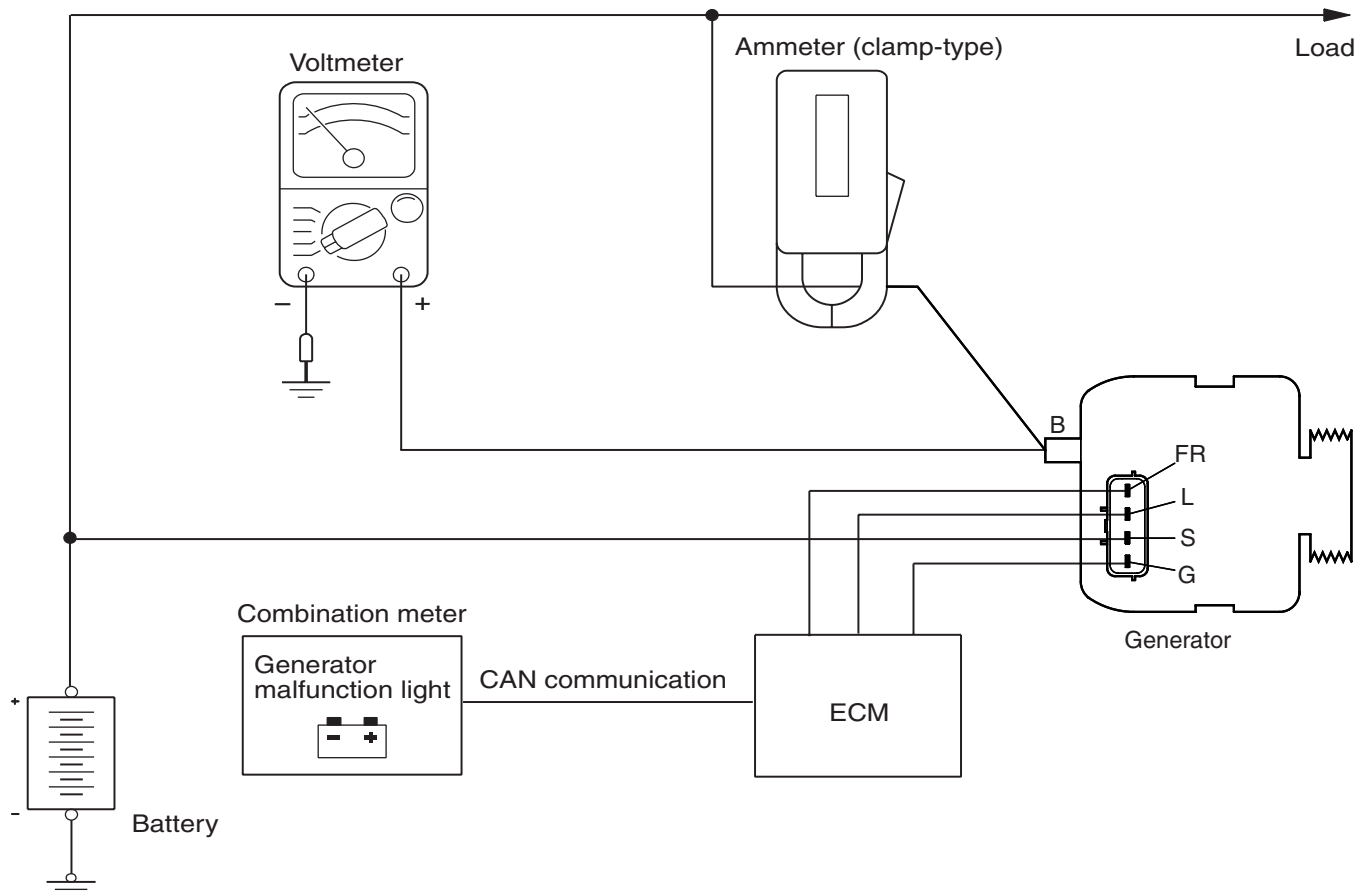

AK604149 AB

**Required Special Tool:**

MB991958: Scan Tool (M.U.T.-III Sub Assembly)

- MB991824: V.C.I.
- MB991827: M.U.T.-III USB Cable



- MB991910: M.U.T.-III Main Harness A

This test determines whether the generator outputs normal current. For best results, use a charging system tester. If not available, follow the steps below.

**⚠ WARNING**

**Battery posts, terminals and related accessories contain lead and lead compounds.**

**WASH HANDS AFTER HANDLING.**

1. Before the test, always be sure to check the following.
  - Generator installation
  - Battery (Refer to GROUP 54A, Chassis Electrical –Battery –On-vehicle Service –Battery Test P.54A-9.)
 

*NOTE: The battery to be used should be slightly discharged. The load in a fully-charged battery will be insufficient and the test may not be able to be carried out correctly.*
  - Generator drive belt tension (Refer to GROUP 00, General –Maintenance Service –Drive Belts (For Generator, Power Steering Pump and Air Conditioning) (Check) P.00-66.)
  - Fusible link
  - Abnormal noise from the generator while the engine is running.
2. Turn the ignition switch to the "LOCK" (OFF) position.
3. Disconnect the negative battery cable.
4. Set a clamp-type DC test ammeter to the generator "B" terminal output wire.
 

*NOTE: Disconnecting the generator output wire and connecting the ammeter may not thoroughly diagnosis an output current drop problem because of an insufficient connection between terminal "B" and the output wire.*
5. Connect a voltmeter with a range of 0 –20 V between the generator "B" terminal and ground. (Connect the positive lead of the voltmeter to the "B" terminal, and then connect the negative lead of the voltmeter to ground.)
6. Connect the negative battery cable.
7. Connect an engine tachometer or scan tool MB991958.
8. Leave the hood open.
9. Check to be sure that the reading on the voltmeter is equal to the battery positive voltage.

*NOTE: If the voltage is 0 V, the cause is probably an open circuit in the wire or fusible link between the generator "B" terminal and the battery positive terminal or malfunctioning voltmeter.*

10. After turning on the headlights, start the engine.
 

*NOTE: Because the current from the battery will soon drop after the engine is started, step 11 should be carried out as quickly as possible in order to obtain the maximum current output value.*
11. Immediately after setting the headlights to high beam, turning on the air conditioner switch and turning the heater blower switch to the highest position, increase the engine speed to 2,500 r/min and read the maximum current output value displayed on the ammeter.
 

**Limit value: 70 % of nominal current output**

*NOTE: For the nominal current output, refer to the Generator Specifications.*

*NOTE: The current output value will depend on the electrical load and the temperature of the generator body.*

*NOTE: If the electrical load is small while testing, the specified level of current may not be output even though the generator is normal. In such cases, increase the electrical load by leaving the headlights turned on for some time to discharge the battery or by using the lighting system in another vehicle, and then test again.*

*NOTE: The specified level of current also may not be output if the temperature of the generator body or the ambient temperature is too high. In such cases, cool the generator and then test again.*
12. The reading on the ammeter should be above the limit value. If the reading is below the limit value and the generator output wire is normal, remove the generator from the engine and check the generator.
13. Run the engine at idle speed after the test.
14. Turn the ignition switch to the "LOCK" (OFF) position.
15. Disconnect the engine tachometer or scan tool MB991958.
16. Disconnect the negative battery cable.
17. Disconnect the ammeter and voltmeter.
18. Connect the negative battery cable.

## REGULATED VOLTAGE TEST

M1161001101625

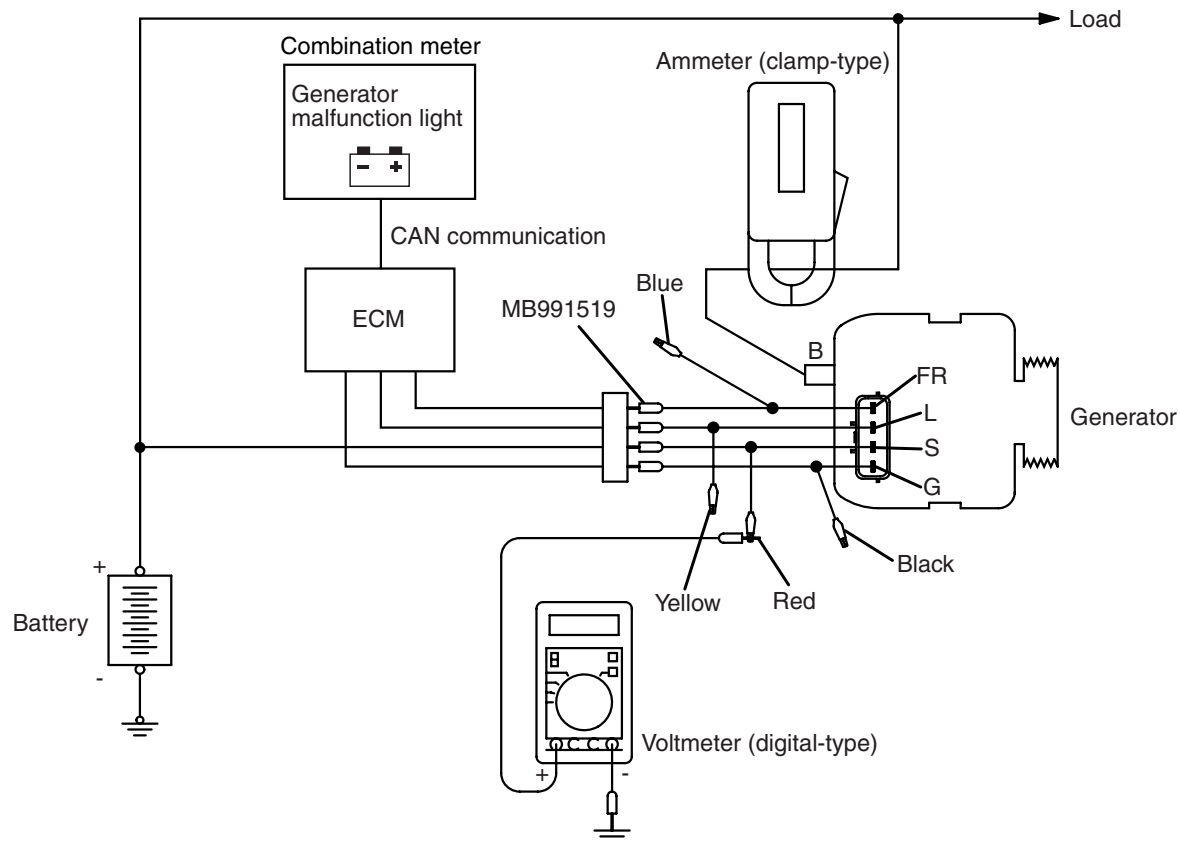

AK503329 AB

**Required Special Tools:**

- MB991958: Scan Tool (M.U.T.-III Sub Assembly)
  - MB991824: V.C.I.
  - MB991827: M.U.T.-III USB Cable
  - MB991910: M.U.T.-III Main Harness A
- MB991519: Generator Harness Connector

This test determines whether the voltage regulator is correctly controlling the generator output voltage.

**⚠ WARNING**

**Battery posts, terminals and related accessories contain lead and lead compounds. WASH HANDS AFTER HANDLING.**

1. Always be sure to check the following before the test:
  - Generator installation
  - Check to be sure that the battery installed in the vehicle is fully charged. (Refer to GROUP 54A, Chassis Electrical –Battery –On-vehicle Service – Battery Test P.54A-9.)
  - Generator drive belt tension (Refer to GROUP 00, General –Maintenance Service –Drive Belts (For Generator, and Air Conditioning) (Check) P.00-66.)
  - Fusible link

- Abnormal noise from the generator while the engine is running.
2. Turn the ignition switch to the "LOCK" (OFF) position.
  3. Disconnect the negative battery cable.
  4. Use the special tool (Generator harness connector: MB991519) to connect a digital-type voltmeter between the generator "S" terminal and ground. (Connect the positive lead of the voltmeter to the "S" terminal, and then connect the negative lead of the voltmeter to a secure ground or to the negative battery terminal.)
  5. Set a clamp-type DC test ammeter to the generator "B" terminal output wire.
  6. Reconnect the negative battery cable.
  7. Connect an engine tachometer, or scan tool MB991958.
  8. Turn the ignition switch to the "ON" position and check that the reading on the voltmeter is equal to the battery positive voltage.

**NOTE:** If the voltage is 0 V, the cause is probably an open circuit in the wire or fusible link between the generator "S" terminal and the battery positive terminal or malfunctioning voltmeter.

9. Check to be sure that all lights and accessories are off.
10. Start the engine.
11. Increase the engine speed to 2,500 r/min.
12. Read the value displayed on the voltmeter when the current output by the generator becomes 15 A or less.
13. If the voltage reading conforms to the value in the voltage regulation table, then the voltage regulator is operating normally.

If the voltage is outside the standard value, there is a malfunction of the voltage regulator or the generator (Refer to the following table).

*NOTE: When the voltage is approximately 12.8 V, the G-terminal is supposed to have a short circuit to the earth. Check the circuits relating to the G-terminal on the generator. (Refer to GROUP 13A –Troubleshooting –Inspection chart for trouble symptoms)*

14. After the test, lower the engine speed to idle.
15. Turn the ignition switch to the "LOCK" (OFF) position.
16. Disconnect the engine tachometer or scan tool MB991958.
17. Disconnect the negative battery cable.
18. Disconnect the ammeter and voltmeter.
19. Remove the special tool (Generator harness connector: MB991519), and return the connector to the original condition.
20. Connect the negative battery cable.

**VOLTAGE REGULATION TABLE**

INSPECTION TERMINAL	VOLTAGE REGULATOR AMBIENT TEMPERATURE [° C (° F)]	STANDARD VALUE (V)
Terminal "S"	-20 (-4)	14.2 –15.4
	20 (68)	13.9 –14.9
	60 (140)	13.4 –14.6
	80 (176)	13.1 –14.5

**WAVE PATTERN CHECK USING AN OSCILLOSCOPE**

M1161001200663

**MEASUREMENT METHOD**

Connect the oscilloscope special patterns pick-up to the generator "B" terminal.

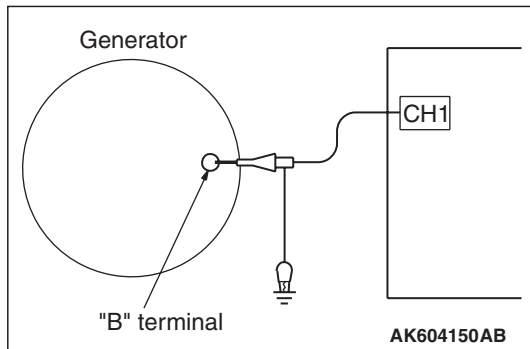

STANDARD WAVEFORM

Observation Conditions	
FUNCTION	SPECIAL PATTERNS
Pattern height	Variable
Variable knob	Adjust while viewing the wave pattern
Pattern selector	Raster
Engine revolutions	Curb idle speed

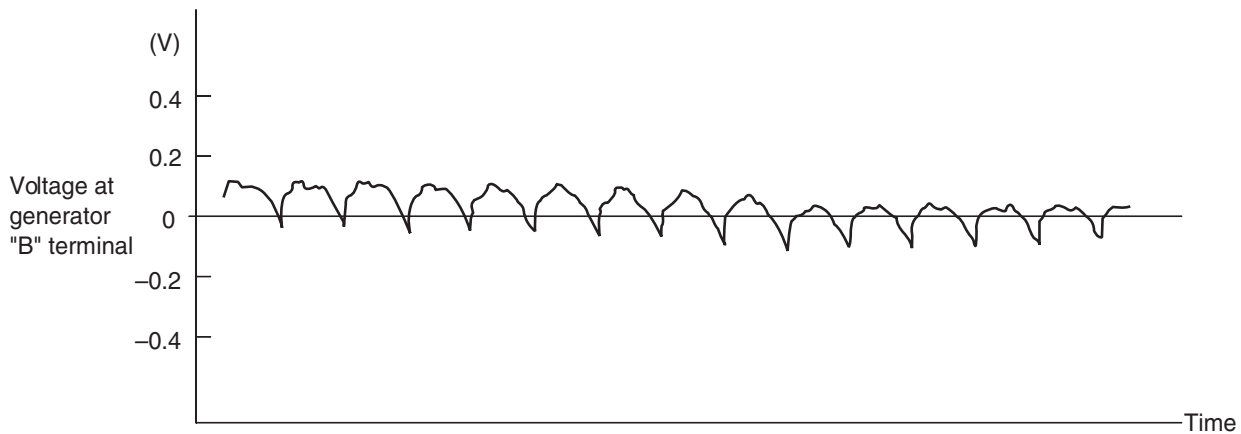

AK604151AB

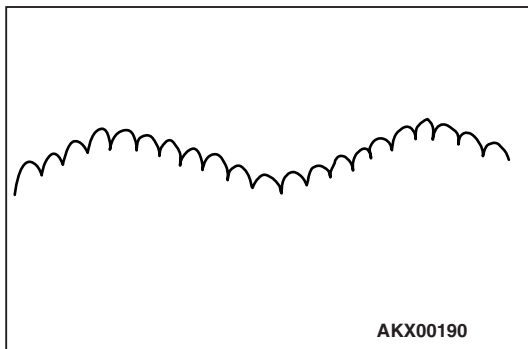

AKX00190

*NOTE: The voltage waveform of the generator "B" terminal can undulate as shown at left. This waveform is produced when the regulator operates according to fluctuations in the generator load (current), and is normal for the generator. If the ripple height is abnormally high (approximately 2 V or more during idling), the wires between the generator "B" terminal and the battery have broken due to fuse blowing, etc. The generator is usually operating properly.*

### ABNORMAL WAVEFORMS EXAMPLES

*NOTE: The size of the waveform patterns can differ greatly, depending on the adjustment of the variable knob on the oscilloscope.*

*NOTE: Identification of abnormal waveforms is easier when there is a large output current (regulator is not operating). (Waveforms can be observed when the headlights are illuminated.)*

*NOTE: Check the conditions of the generator malfunction light (illuminated/not illuminated) also, and carry out a total check.*

#### ABNORMAL WAVEFORMS

- Example 1  
PROBABLE CAUSE: Open circuit or short circuit in diode



AK703778

- Example 2  
PROBABLE CAUSE: Open circuit in stator coil (In stator coil)



AK703780

- Example 3  
PROBABLE CAUSE: Open circuit in stator coil (Open circuit between stator coil and diode)



AK703781

- Example 4  
PROBABLE CAUSE: Short circuit in stator coil



AK703782

**GENERATOR ASSEMBLY  
REMOVAL AND INSTALLATION**

M1161001402414

<p><b>Pre-removal operation</b></p> <ul style="list-style-type: none"> <li>• Engine Room Under Cover Front A, B, Engine Room Under Cover Center and Engine Room Side Cover (RH) Removal (Refer to GROUP 51, Under Cover P.51-16).</li> <li>• Drive Belt Removal (Refer to GROUP 11A, Crankshaft Pulley P.11A-21).</li> <li>• Fan, Fan Motor and Fan Shroud Assembly Removal (Refer to GROUP 14, Radiator P.14-31).</li> </ul>	<p><b>Post-installation operation</b></p> <ul style="list-style-type: none"> <li>• Fan, Fan Motor and Fan Shroud Assembly Installation (Refer to GROUP 14, Radiator P.14-31).</li> <li>• Drive Belt Installation (Refer to GROUP 11A, Crankshaft Pulley P.11A-21).</li> <li>• Drive Belt Tension Check (Refer to GROUP 11A, On-vehicle Service –Drive Belt Tension Check P.11A-8).</li> <li>• Engine Room Under Cover Front A, B, Engine Room Under Cover Center and Engine Room Side Cover (RH) Installation (Refer to GROUP 51, Under Cover P.51-16).</li> </ul>
---	--

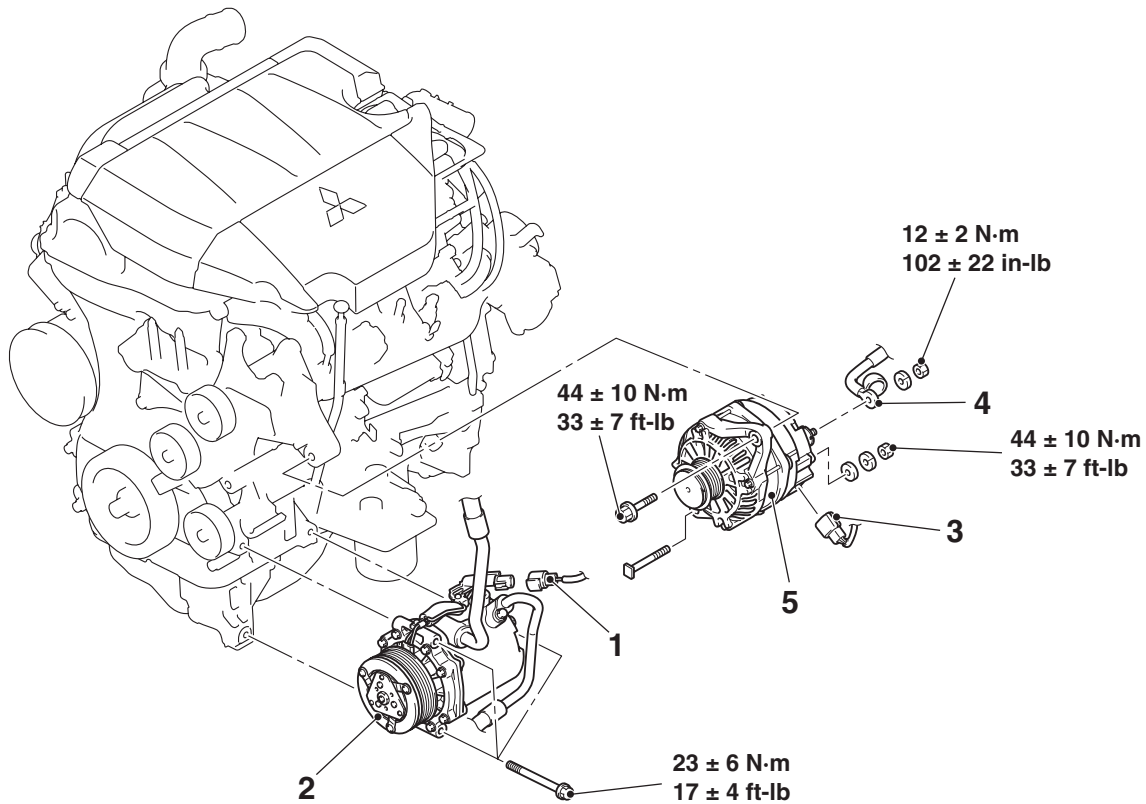

AC709276AB

		Removal steps		Removal steps (Continued)
<<A>>	>>A<<	1. A/C compressor and clutch assembly connector connection	<<B>>	3. Generator connector connection
		2. A/C compressor and clutch assembly		4. Generator terminal connection
				5. Generator assembly

## REMOVAL SERVICE POINTS

### <<A>> A/C COMPRESSOR AND CLUTCH ASSEMBLY REMOVAL

1. With the hose installed, remove the A/C compressor and clutch assembly from the bracket.
2. Tie the removed A/C compressor and clutch assembly with a string at a position where it will not interfere with the removal and installation of the generator assembly.

### <<B>> GENERATOR ASSEMBLY REMOVAL

Pull out the generator assembly upward.

## INSTALLATION SERVICE POINT

### >>A<< A/C COMPRESSOR AND CLUTCH ASSEMBLY INSTALLATION

Tighten A/C compressor and clutch assembly mounting bolts to the specified torque in the order of number shown in the illustration.

**Tightening torque: 23 ± 6 N·m (17 ± 4 ft-lb)**

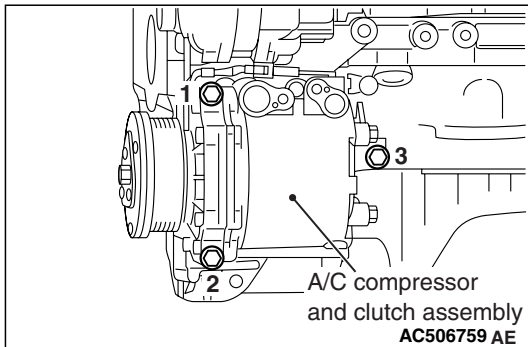

DISASSEMBLY AND ASSEMBLY

M1161001600519

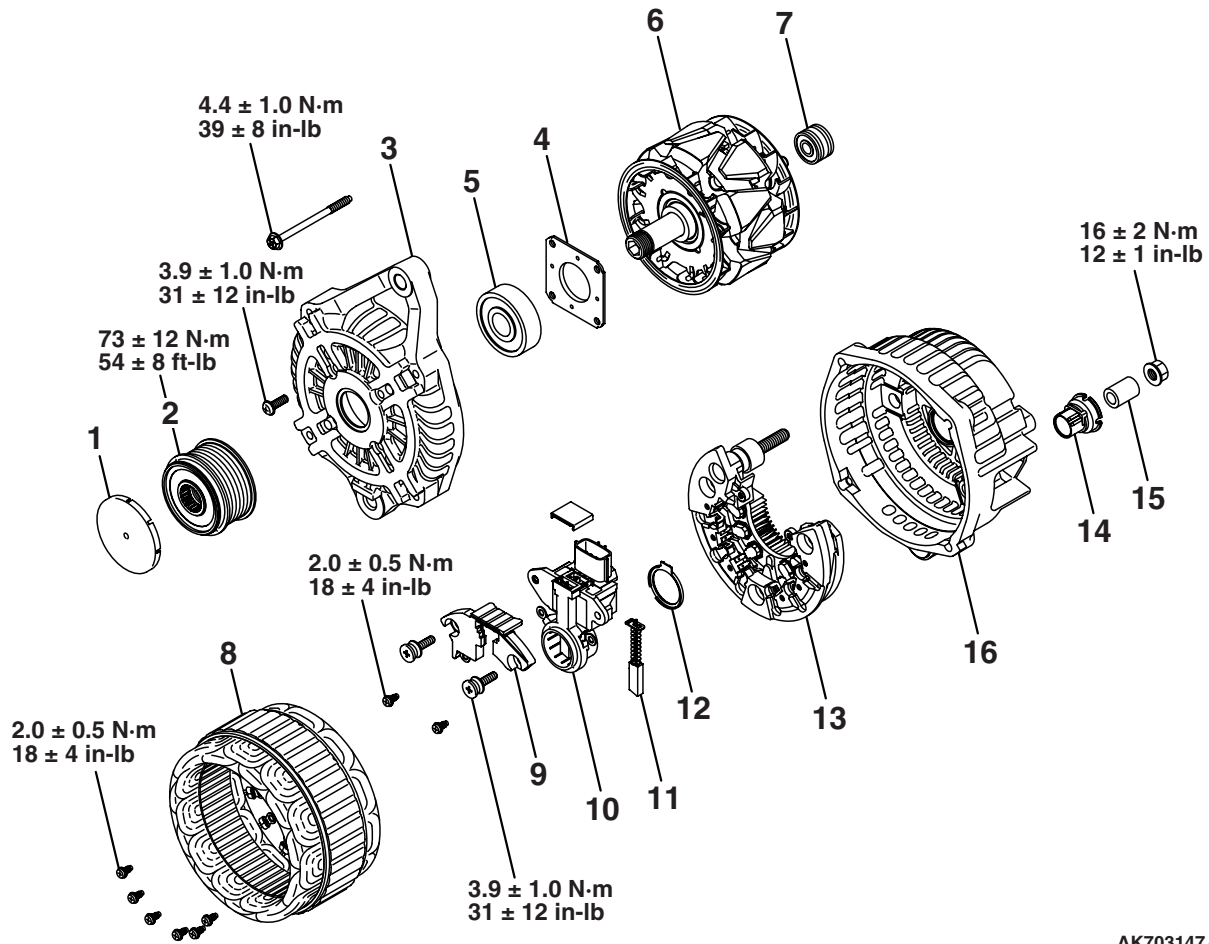

AK703147AC

**disassembly steps**

- <<A>> >>C<< 1. Cap
- <<B>> >>B<< 2. Pulley
- <<B>> >>B<< 3. Front bracket
- 4. Plate
- 5. Front bearing
- 6. Rotor
- 7. Rear bearing
- <<C>> 8. Stator

**disassembly steps (Continued)**

- <<C>> >>A<< 9. Condenser assembly
- <<C>> >>A<< 10. Regulator assembly
- 11. Brush
- 12. Rubber packing
- 13. Rectifier
- 14. Insulator
- 15. Bushing
- 16. Rear bracket

**Required Special Tool:**

- MB992226: Serration Socket



## DISASSEMBLY SERVICE POINTS

### <<A>> PULLEY REMOVAL

1. Set the special tool MB992226 to the pulley.

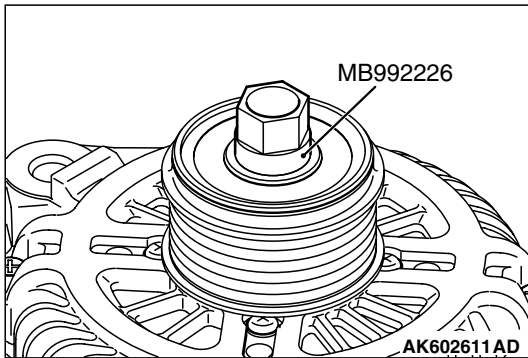

2. Set the closed wrench to the hexagonal area of the special tool MB992226.

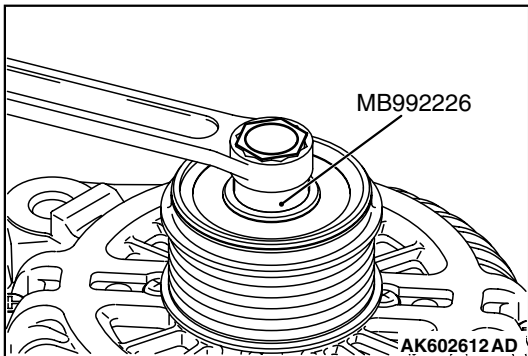

3. Insert the hexagonal bit socket having width across flats of 10 mm into the hexagonal area of the rotor shaft.

4. Hold the pulley with the closed wrench. Rotate the rotor shaft clockwise to remove the pulley.

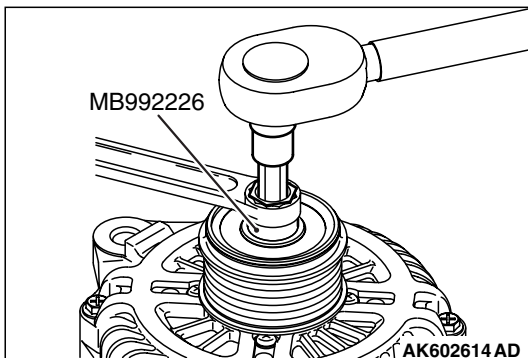

### <<B>> FRONT BRACKET REMOVAL

#### **⚠ CAUTION**

**Do not insert the screwdriver blades too deep. Doing so could damage the stator coil.**

Insert the blades of screwdrivers between the front bracket and stator core, and pry and separate them with the screwdrivers.

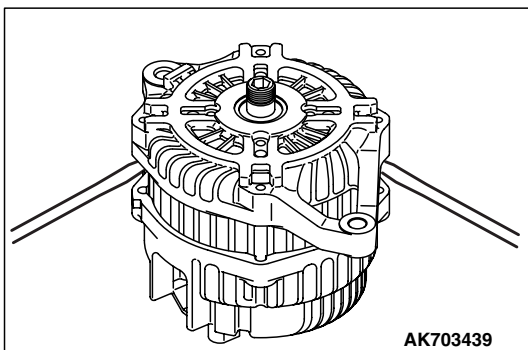

**<<C>> STATOR / REGULATOR ASSEMBLY  
REMOVAL**

1. Remove 6 installation screws of the stator lead wire, and then remove the stator.
2. Remove 4 installation screws of the regulator to remove the regulator assembly.

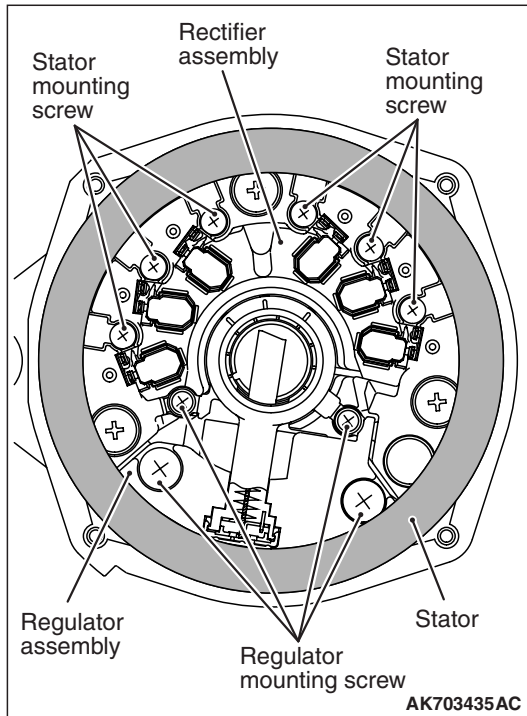
**REASSEMBLY SERVICE POINTS****>>A<< REGULATOR ASSEMBLY INSTALLATION**

After installing the regulator assembly, insert a piece of wire through the hole in the rear bracket while pressing the brush to keep the brush against movement.

*NOTE: Unless inserting the wire to fix the brush, the rotor installation is difficult.*

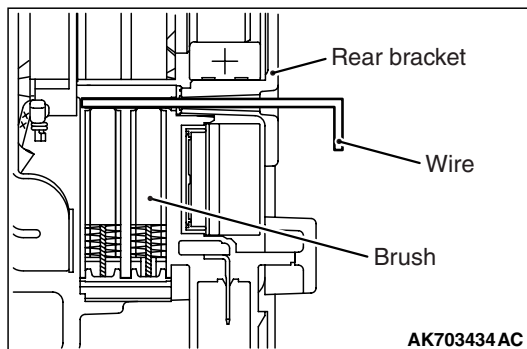
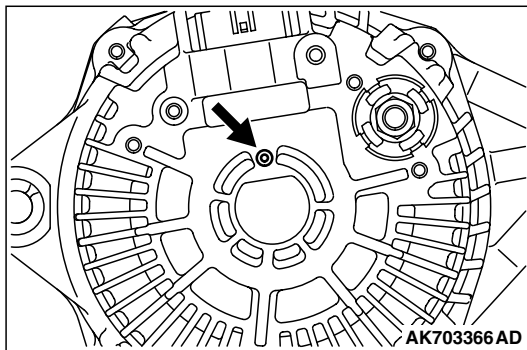

**>>B<< ROTOR INSTALLATION**

Remove the brush holding wire after the rotor has been installed.

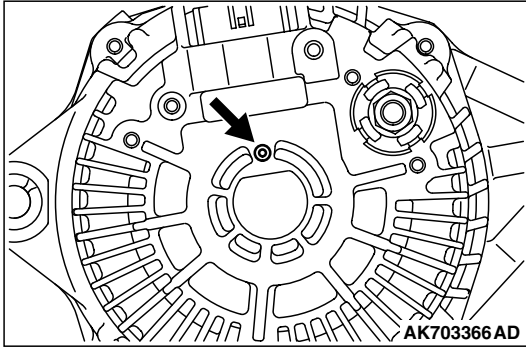

**>>C<< PULLEY INSTALLATION**

1. Clean the inner race of the front bearing and that of the pulley.
2. Screws the inner race of the pulley until it touches the inner race of the front bearing.

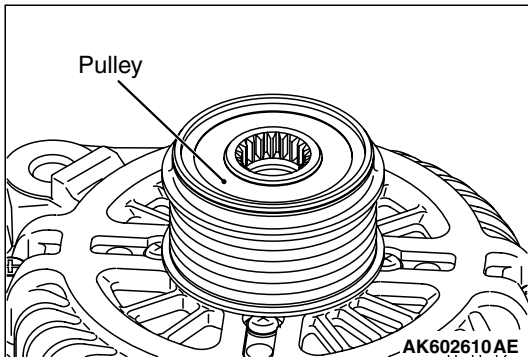
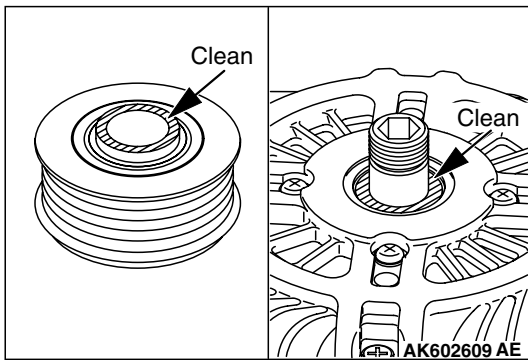

3. Set the special tool MB992226 to the pulley.

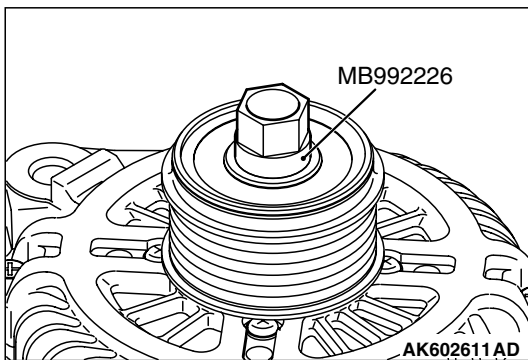

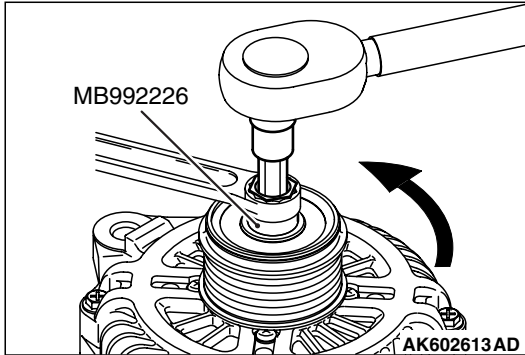
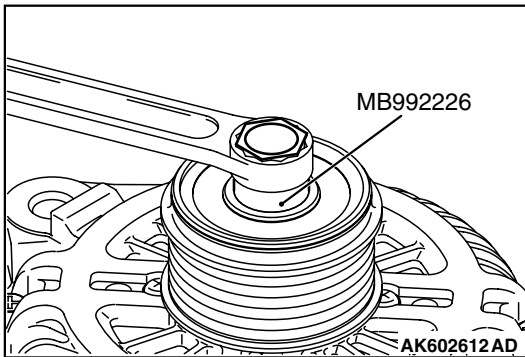

- Set the closed wrench to the hexagonal area of the special tool MB992226.

- Insert the hexagonal bit socket having width across flats of 10 mm (0.4 inch) into the hexagonal area of the rotor shaft.
- Hold the pulley with the closed wrench. Rotate the hexagonal bit socket counterclockwise to tighten it to the specified torque.

**Specified torque: 73 ± 12 N·m (54 ± 8 ft-lb)**

## INSPECTION

M1161001700431

### PULLEY

- Set the special tool MB992226 to the pulley.
- Fix the special tool MB992226, with the glasses wrench to prevent the rotor shaft from rotating.
- Lock the pulley when rotating it clockwise. Check that the pulley rotates smoothly when rotating it counterclockwise.

#### **CAUTION**

**Locking the one-way clutch might cause the damaged drive belt and an abnormal noise.**

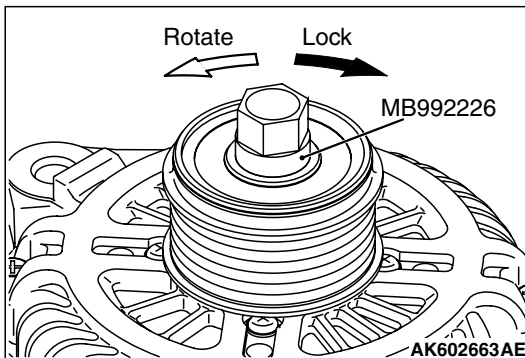

### ROTOR

- Measure the resistance between the two slip rings of the rotor coil to check the continuity between them. Replace the rotor if the resistance is not within the standard value range.

**Standard value: 2.0 – 2.3 Ω**

- Check the continuity between the slip rings and core.

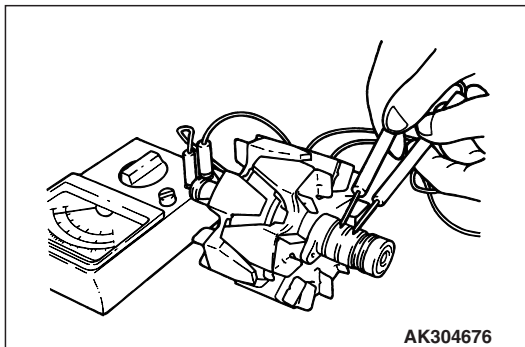

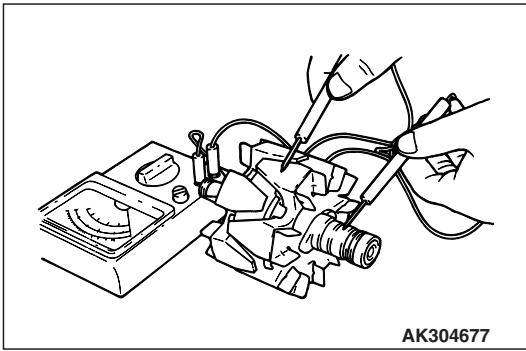

3. If continuity is present, replace the rotor.

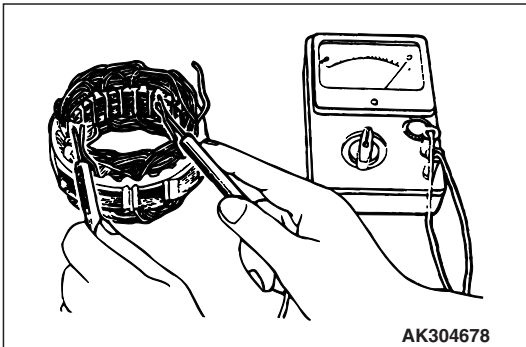

**STATOR**

1. Check the continuity between coil leads.  
If there is no continuity, replace the stator.

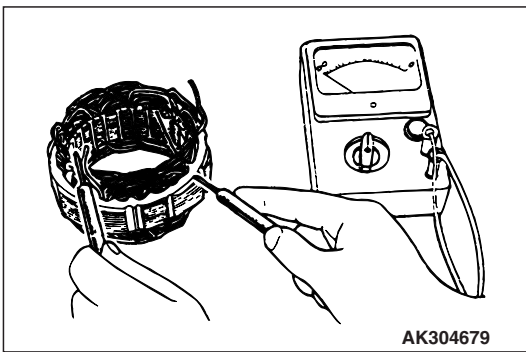

2. Check the continuity between coil and core.  
If there is continuity, replace the stator.

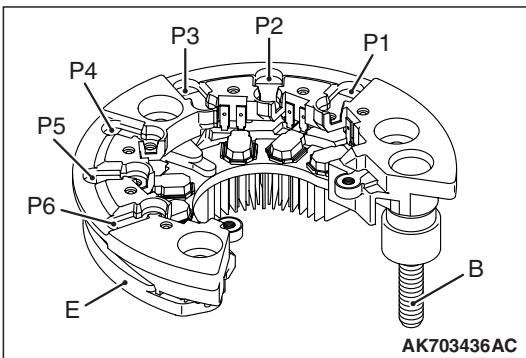

**RECTIFIER ASSEMBLY**

Use the analog type tester to make sure the electrical continuity of each diode meets the table.

Unless the electrical continuity of each diode meets the table, replace the rectifier.

(-) side	(+) side	Electrical continuity
E	P1, P2, P3, P4, P5, P6	Yes
B		No
P1, P2, P3, P4, P5, P6	E	No
	B	Yes

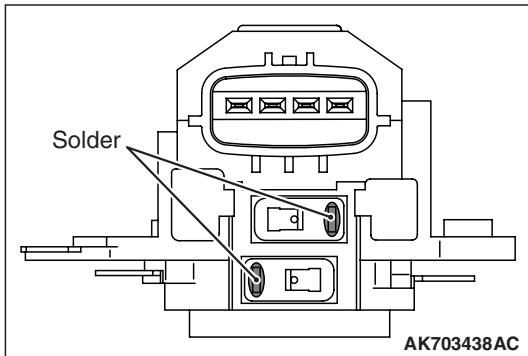
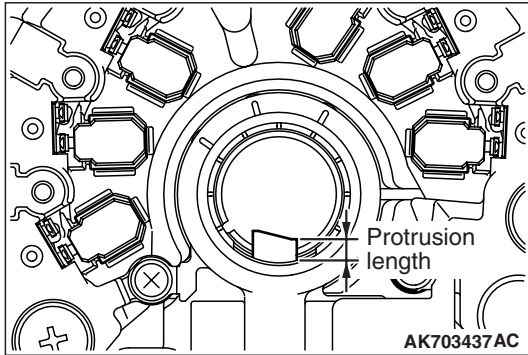

## BRUSH

1. Measure the length of the protrusion of the brush. Replace the brush if the protrusion length is shorter than the limit.

**Limit: 2 mm (0.1 inch) minimum**

2. Unsolder the lead of the brush. The brush will come out, becoming ready for removal.
3. Install a new brush by pushing it into the holder as shown in the drawing and soldering the lead.

# STARTING SYSTEM

## GENERAL INFORMATION

If the ignition switch is turned to the "START" position, current flows in the coil provided inside magnetic switch, attracting the plunger. When the plunger is attracted, the lever connected to the plunger is actuated to engage the starter clutch.

On the other hand, attracting the plunger will turn on the magnetic switch, allowing the "B" terminal and "M" terminal to conduct. Thus, current flows to engage the starter motor.

M1161000101309

When the ignition switch is returned to the "ON" position after starting the engine, the starter clutch is disengaged from the ring gear.

An overrunning clutch is provided between the pinion and the armature shaft, to prevent damage to the starter.

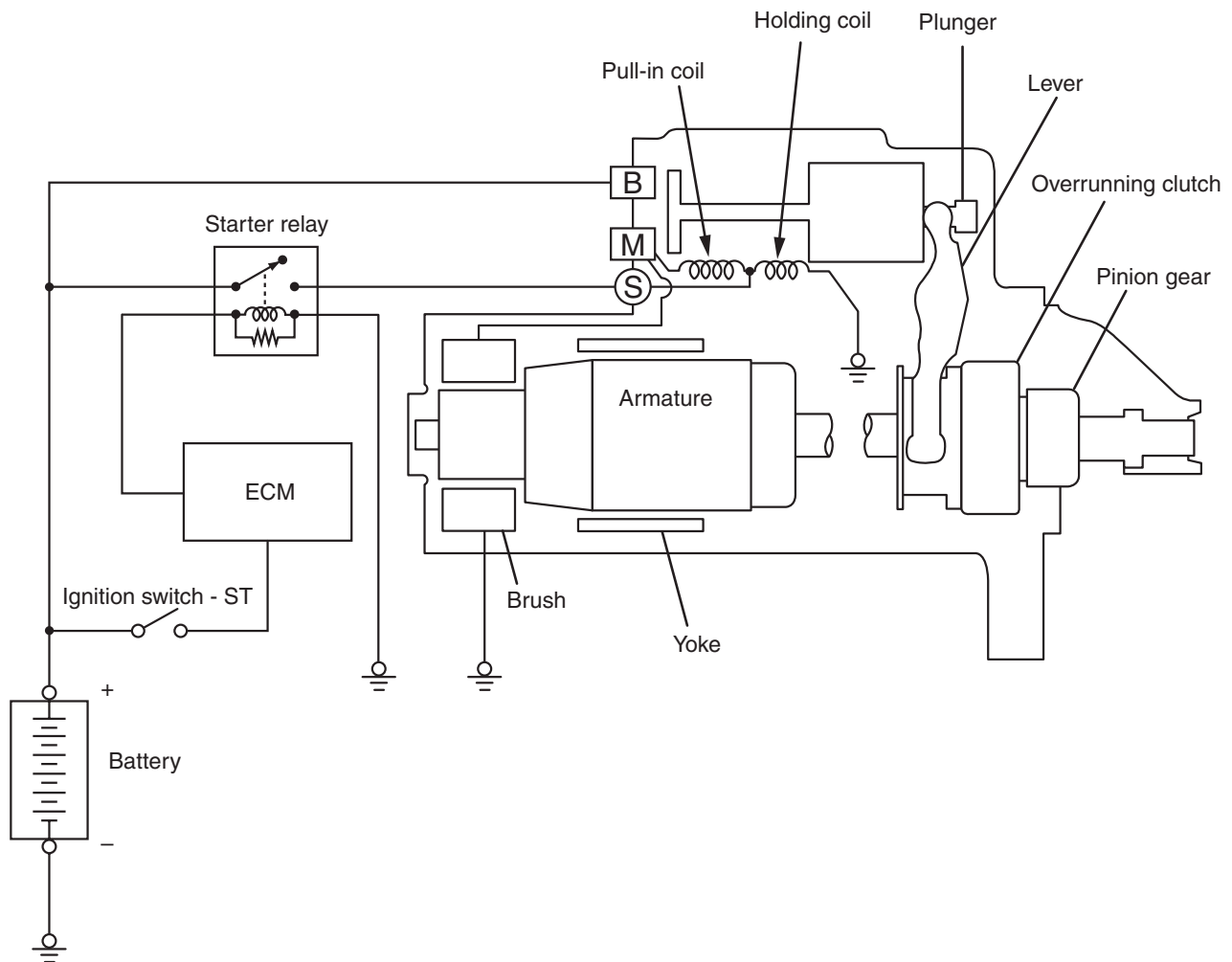

AK604152AB

## OPERATION

For models equipped with TC-SST, when the ignition switch is turned to the "ST" position while the selector lever is at the "P" or "N" position, the contact (magnetic switch) of the starter is switched ON and the starter motor is activated.

## GENERAL SPECIFICATIONS

M1162000200083

ITEMS	M/T	TC-SST
Type	Reduction drive with planetary gear	
Identification number	M000T21571	M000T22871
Part No.	1810A011	1810A123
Rated output kW/V	1.4/12	
Number of pinion teeth	8	9

## SERVICE SPECIFICATIONS

M1162000300466

ITEMS		STANDARD VALUE	LIMIT
Free running characteristics	Terminal voltage V	11	—
	Current A	90	—
	Speed r/min	2,000 or more <M/T> 2,400 or more <TC-SST>	—
Pinion gap mm (in)		0.5 –2.0 (0.02 –0.07)	—
Commutator run-out mm (in)		0.05 (0.002)	Minimum 0.1 (0.004)
Commutator diameter mm (in)		29.4 (1.16)	Minimum 28.8 (1.13)
Undercut depth mm (in)		0.5 (0.02)	Minimum 0.2 (0.008)

## STARTING SYSTEM DIAGNOSIS

M1162000700497

## TROUBLESHOOTING HINTS

The starter motor does not operate at all.

 **WARNING**

**Battery posts, terminals and related accessories contain lead and lead compounds. WASH HANDS AFTER HANDLING.**

- Check the starter (coil).
- Check for poor contact at the battery terminals and starter.
- Check the transmission range switch.

The starter motor doesn't stop

- Check the starter (magnetic switch).



---

**TROUBLESHOOTING GUIDE**

The starting system troubleshooting guide is shown in the following steps.

**⚠ WARNING**

***Battery posts, terminals and related accessories contain lead and lead compounds. WASH HANDS AFTER HANDLING.***

---

**STEP 1.**

**Q: Is the battery in good condition? (Refer to GROUP 54A, Chassis Electrical –Battery –On-vehicle Service – Battery Test [P.54A-9](#).)**

**YES :** Go to Step 2.

**NO :** Charge or replace the battery.

---

**STEP 2.**

- Disconnect the starter motor S (solenoid) terminal connector.
- Using a jumper wire, apply battery positive voltage to the starter motor S (solenoid) terminal.
- Check the engine condition.  
OK: Turns normally

**Q: Does the starter motor operate normally?**

- YES :**
- Check the ignition switch (Refer to GROUP 54A, Chassis Electrical –Ignition Switch –Ignition Switch –Inspection [P.54A-271](#).)
  - Check the starter relay system (Refer to GROUP 13A, Multiport Fuel Injection (MFI) –Multiport Fuel Injection (MFI) Diagnosis –Symptom Procedures – Ignition Switch –ST System and Starter Relay System [P.13A-818](#) <M/T>, [P.13A-830](#) <TC-SST>).
  - Check the shift lever position. (Refer to GROUP 22C, Twin Clutch-sportronic Shift Transmission (TC-SST) –On-vehicle Service –Shift Lever Operation Check [P.22C-330](#).)
  - Check the line between the battery and starter motor S (solenoid) terminal.

**NO :** Go to Step 3.

---

**STEP 3.**

- Check the cable between starter B (battery) terminal and battery positive terminal for connection and continuity.

**Q: Is the starter cable in good condition?**

**YES :** Go to Step 4.

**NO :** Repair or replace the cable.

**STEP 4.**

- Check the connection and the continuity of the cable between the starter motor body and the negative battery terminal.

**Q: Is the ground line in good condition?**

**YES :** Go to Step 5.

**NO :** Repair or replace the cable.

**STEP 5.**

**Q: Is the starter motor in good condition? (Refer to Starting System –Starter Motor Assembly –Inspection P.16-20.)**

**YES :** Excessive rotational resistance of the engine.

**NO :** Replace the starter motor.

**ON-VEHICLE SERVICE**

**STARTER RELAY CHECK**

M1162001400831

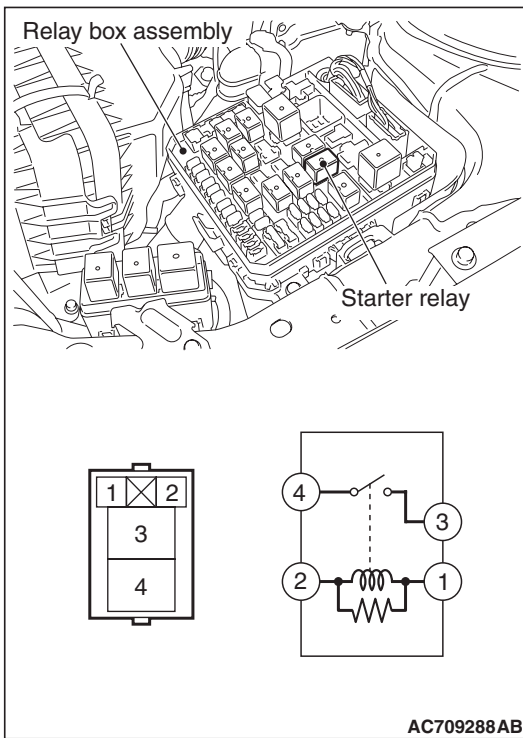

Battery voltage	Terminal No. to be connected to tester	Continuity test result
Not applied	4 –3	Open circuit
Connect terminal No.2 and battery (+) terminal. Connect terminal No.1 and battery (-) terminal.		Continuity (Less than 2 ohms)

**STARTER MOTOR ASSEMBLY  
REMOVAL AND INSTALLATION**

M1162001002260

**Pre-removal operation**

- Engine Room Under Cover Front A, B and Engine Room Under Cover Center Removal (Refer to GROUP 51, Under Cover P.51-16).
- Air Cleaner Body Removal (Refer to GROUP 15, Air Cleaner P.15-10).
- Charge Air Cooler Outlet Hose E Removal (Refer to GROUP 15, Charge Air Cooler P.15-10).

**Post-installation operation**

- Charge Air Cooler Outlet Hose E Installation (Refer to GROUP 15, Charge Air Cooler P.15-10).
- Air Cleaner Body Installation (Refer to GROUP 15, Air Cleaner P.15-10).
- Engine Room Under Cover Front A, B and Engine Room Under Cover Center and Engine Room Side Cover (RH) Installation (Refer to GROUP 51, Under Cover P.51-16).

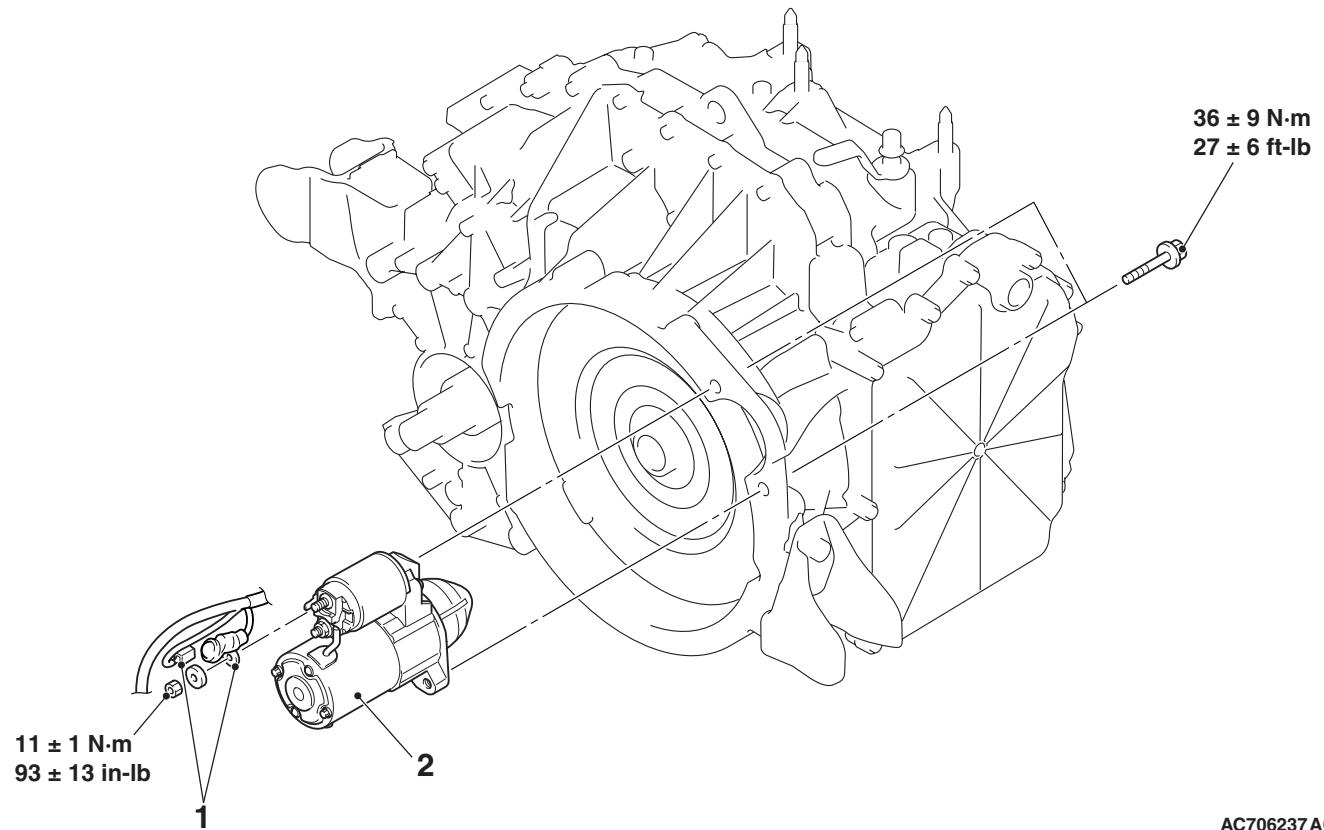

**Removal steps**

1. Starter connector and terminal connection
2. Starter assembly

<<A>>

**REMOVAL SERVICE POINT**

**<<A>> STARTER ASSEMBLY REMOVAL**

Remove the starter assembly from the lower front of the engine.

## INSPECTION

## PINION GAP ADJUSTMENT

1. Disconnect the lead wire from the M-terminal of the magnetic switch.
2. Connect a 12-volt battery between the S-terminal and M-terminal.

**⚠ CAUTION**

**This test must be performed quickly (in less than 10 seconds) to prevent the coil from burning.**

3. Set the switch to "ON", and the pinion will move out.

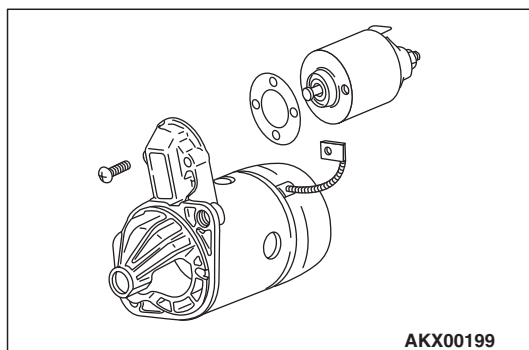
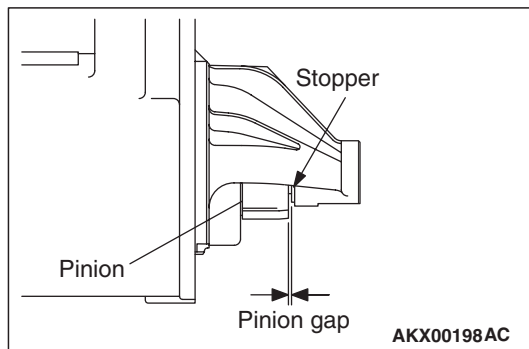
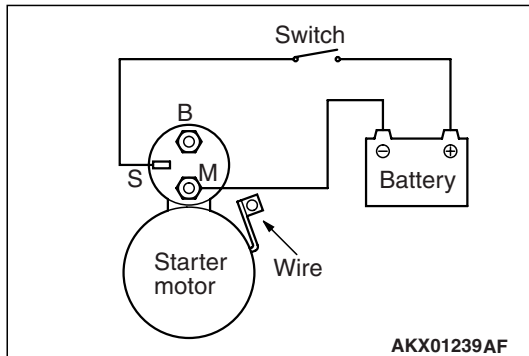

4. Check the pinion-to-stopper clearance (pinion gap) with a feeler gauge.

**Standard value: 0.5 –2.0 mm (0.02 –0.07 inch)**

5. If the pinion gap is out of specification, adjust by adding or removing gasket(s) between the magnetic switch and front bracket.

## MAGNETIC SWITCH PULL-IN TEST

1. Disconnect the field coil wire from the M-terminal of the magnetic switch.

**⚠ CAUTION**

**This test must be performed quickly (in less than 10 seconds) to prevent the coil from burning.**

2. Connect a 12-volt battery between the S-terminal and M-terminal.
3. If the pinion moves out, the pull-in coil is good. If it doesn't, replace the magnetic switch.

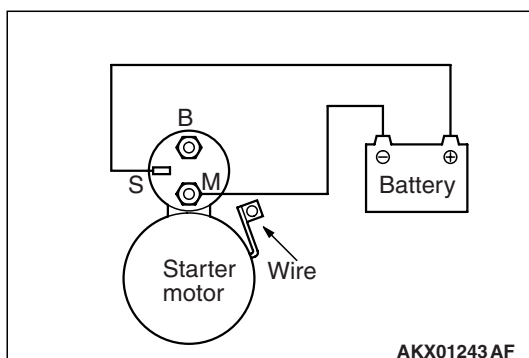

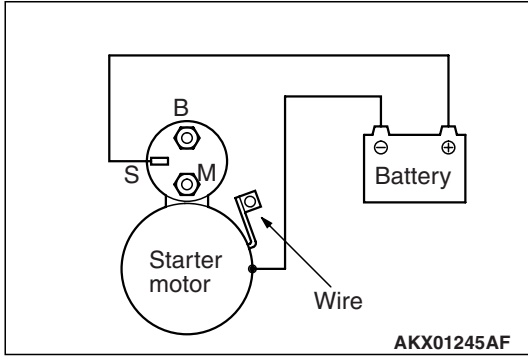

### MAGNETIC SWITCH HOLD-IN TEST

1. Disconnect the field coil wire from the M-terminal of the magnetic switch.

**⚠ CAUTION**

**This test must be performed quickly (in less than 10 seconds) to prevent the coil from burning.**

2. Connect a 12-volt battery between the S-terminal and body.
3. Manually pull out the pinion as far as the pinion stopper position.
4. If the pinion remains out, everything is operating properly. If the pinion moves in, the hold-in circuit is open. Replace the magnetic switch.

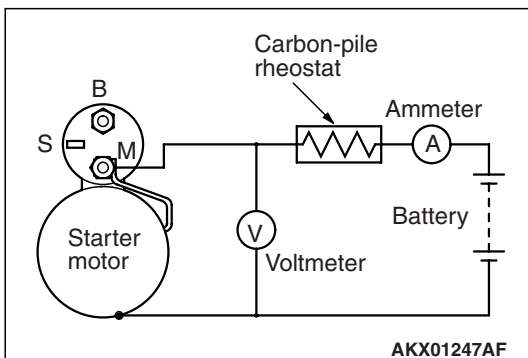

### FREE RUNNING TEST

1. Place the starter motor in a vise equipped with soft jaws and connect a fully-charged 12-volt battery to the starter motor as follows:
2. Connect a test ammeter (100-ampere scale) and carbon pile rheostat in series between the positive battery terminal and starter motor terminal.
3. Connect a voltmeter (15-volt scale) across the starter motor.
4. Rotate carbon pile to full-resistance position.
5. Connect the battery cable from the negative battery terminal to the starter motor body.
6. Adjust the rheostat until the battery positive voltage shown by the voltmeter is 11 V.
7. Confirm that the maximum amperage is within the specifications and that the starter motor turns smoothly and freely.

**Current: maximum 90 Amps**

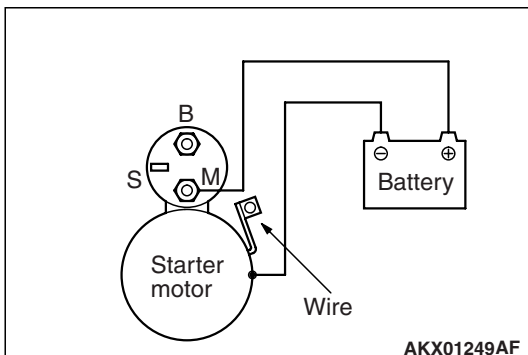

### MAGNETIC SWITCH RETURN TEST

1. Disconnect the field coil wire from the M-terminal of the magnetic switch.

**⚠ CAUTION**

**This test must be performed quickly (in less than 10 seconds) to prevent the coil from burning.**

2. Connect a 12-volt battery between the M-terminal and body.

**⚠ WARNING**

**Be careful not to get your fingers caught when pulling out the pinion.**

3. Pull the pinion out and release. If the pinion quickly returns to its original position, everything is operating properly. If it doesn't, replace the magnetic switch.

DISASSEMBLY AND ASSEMBLY

M1162001200611

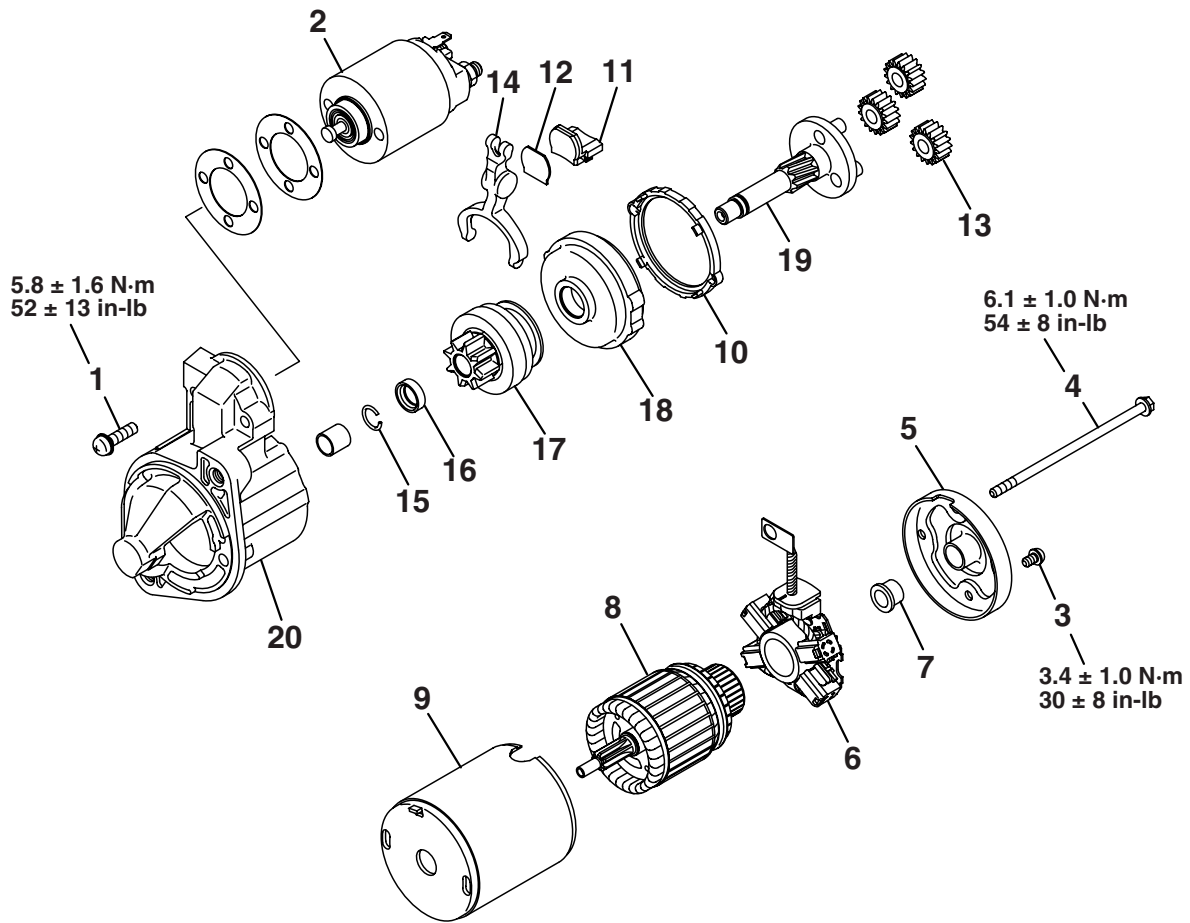

AK704430 AB

<<A>>

DISASSEMBLY STEPS

1. Screw
2. Magnetic switch
3. Screw
4. Bolt
5. Rear bracket
6. Brush holder
7. Rear bearing
8. Armature
9. Yoke assembly
10. Packing A

<<B>> >>A<<  
<<B>> >>A<<

DISASSEMBLY STEPS

11. Packing B
12. Plate
13. Planetary gear
14. Lever
15. Snap ring
16. Stop ring
17. Overrunning clutch
18. Internal gear
19. Planetary gear shaft
20. Front bracket

## DISASSEMBLY SERVICE POINTS

### <<A>> MAGNETIC SWITCH REMOVAL

**⚠ CAUTION**

**Do not clamp the yoke assembly with a vise.**

Disconnect the lead from the M terminal of the magnetic switch.

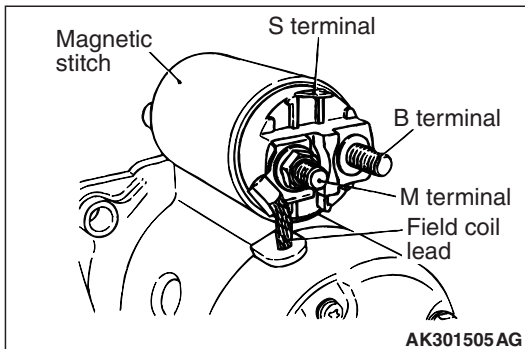

### <<B>> SNAP RING / STOP RING REMOVAL

1. Apply a long socket wrench of an appropriate size to the stop ring and strike the wrench to drive out the stop ring toward the pinion gear side.

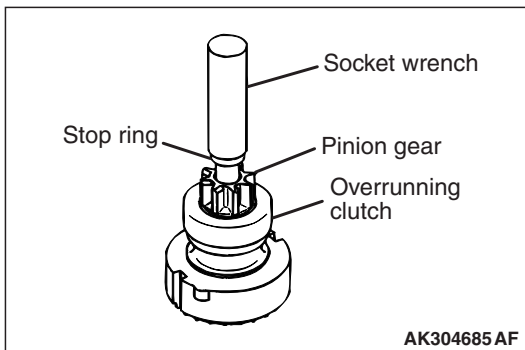

2. Remove the snap ring with snap ring pliers, then remove the stop ring and overrunning clutch.

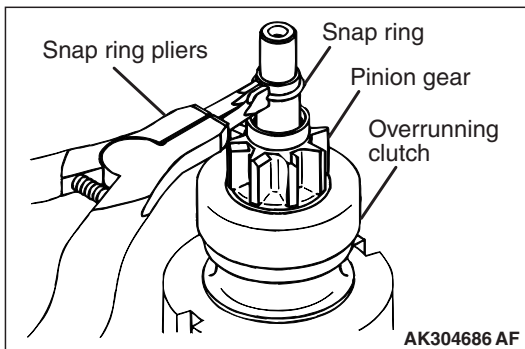

## STARTER MOTOR PARTS CLEANING

1. Never clean in a solvent such starter motor parts as the magnetic switch, brush holder, and armature. If they are soaked in a solvent, their insulation could be impaired. When these parts require cleaning, wipe off contamination with cloth.
2. Never soak the drive unit in a solvent. If it is washed in a solvent, the grease having been packed in the overrunning clutch at the factory will be washed out. Wipe the drive unit with cloth if it requires cleaning.

## REASSEMBLY SERVICE POINTS

## &gt;&gt;A&lt;&lt; STOP RING / SNAP RING INSTALLATION

Use a suitable puller to pull the stop ring until it gets over the snap ring.

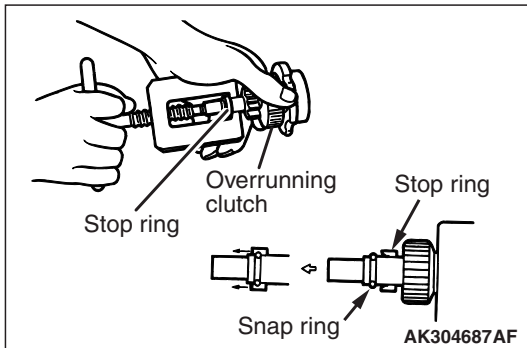

## INSPECTION

M1162001300470

## COMMUTATOR CHECK

1. Place the armature on a pair of V-blocks, and check the deflection by using a dial gauge.

**Standard value: 0.05 mm (0.002 inch)**

**Limit: 0.10 mm (0.004 inch)**

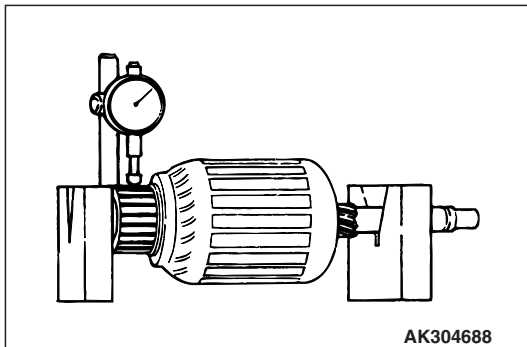

2. Check the outer diameter of the commutator.

**Standard value: 29.4 mm (1.16 inch)**

**Minimum limit: 28.8 mm (1.13 inch)**

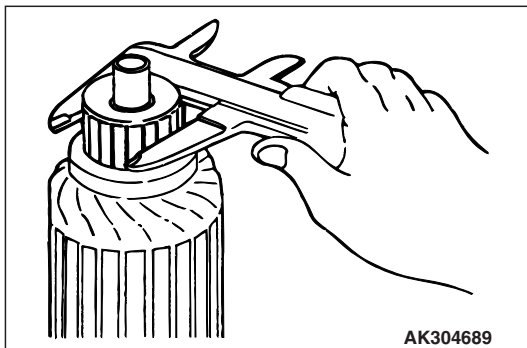

3. Check the depth of the undercut between segments.

**Standard value: 0.5 mm (0.02 inch)**

**Minimum limit: 0.2 mm (0.01 inch)**

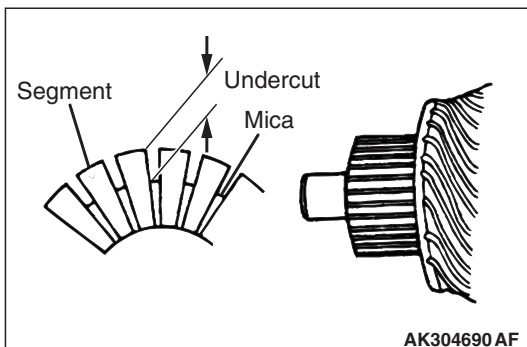



### BRUSH HOLDER

Push the brush into the brush holder to make sure that the spring is working on the brush.  
If the spring is not working, replace the brush holder.

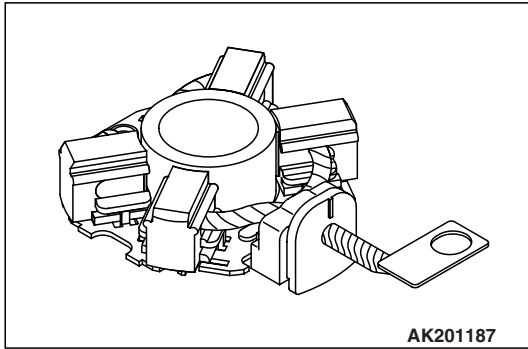

### OVERRUNNING CLUTCH

1. Make sure that the pinion cannot be turned counterclockwise, and can be turned clockwise freely.
2. Check the pinion for abnormal wear and damage.

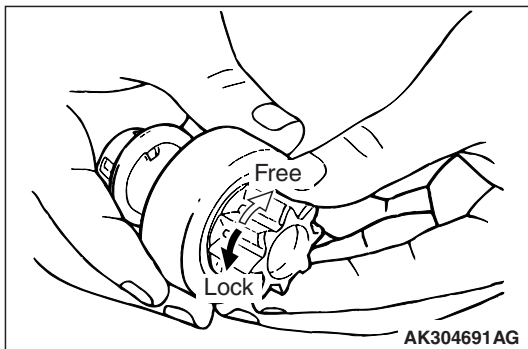

### BRUSHES

1. Check the commutator contacting surface of each brush for abnormal roughness. Also check the height of the brush. Replace the brush holder if the height is lower than the limit.

**Limit: 7.0 mm (0.27 in)**

2. When the contact surface of the brush is rectified or the brush holder is replaced, recondition the contact surface with sandpaper wrapped around the commutator.

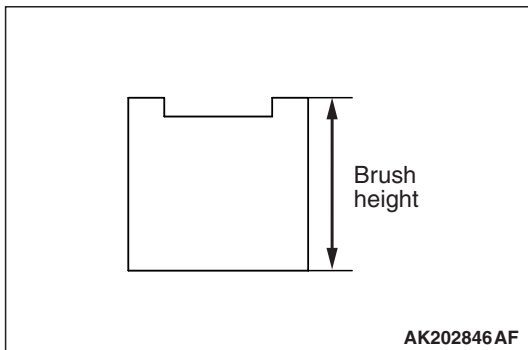

### ARMATURE CHECK

1. Check that the armature coil is not grounded.
2. Place the armature in a growler.
3. Hold a thin steel blade parallel and just above the armature while slowly rotating in the growler. A shorted armature will cause a blade to vibrate and be attracted to the core. Replace the shorted armature.

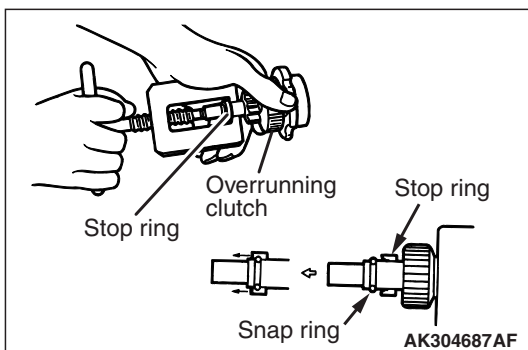

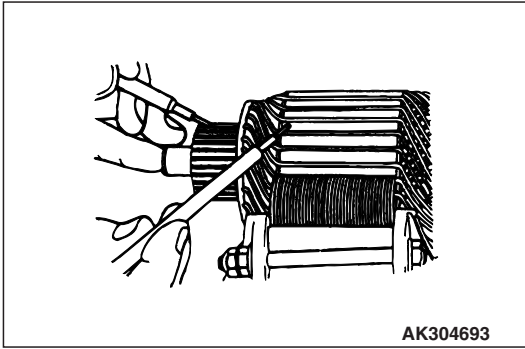

4. Check the insulation between the armature coil cores and the commutator segments. They are normal if there is no continuity.

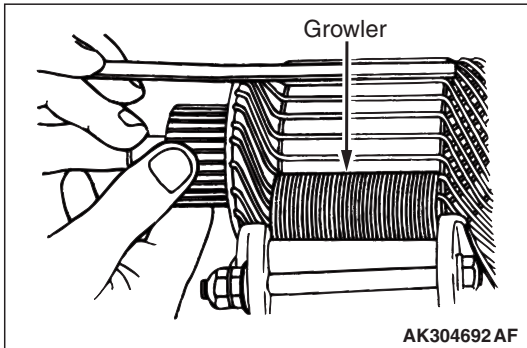

5. Check for continuity between the segments. The condition is normal if there is continuity.

## IGNITION SYSTEM

### GENERAL INFORMATION

This system is equipped with four ignition coils with built-in power transistors for each of the cylinders. Interruption of the primary current flowing in the primary side of an ignition coil generates a high voltage in the secondary side of ignition coil. The high voltage thus generated is applied to the spark plugs to generate sparks. The engine control module (ECM) turns the power transistors inside the ignition coils alternately on and off. This causes the primary currents in the ignition coils to be alternately interrupted and allowed to flow to fire the cylinders in the order 1-3-4-2.

M1163000101015

The ECM determines which ignition coil should be controlled by means of the signals from the camshaft position sensor and the crank angle sensor. It also detects the crankshaft position, in order to provide ignition at the most appropriate timing in response to the engine operation conditions.

When the engine is cold or running at high altitudes, the ignition timing is slightly advanced to provide optimum performance. Furthermore, if knocking occurs, the ignition timing is gradually retarded until knocking ceases.

SYSTEM DIAGRAM

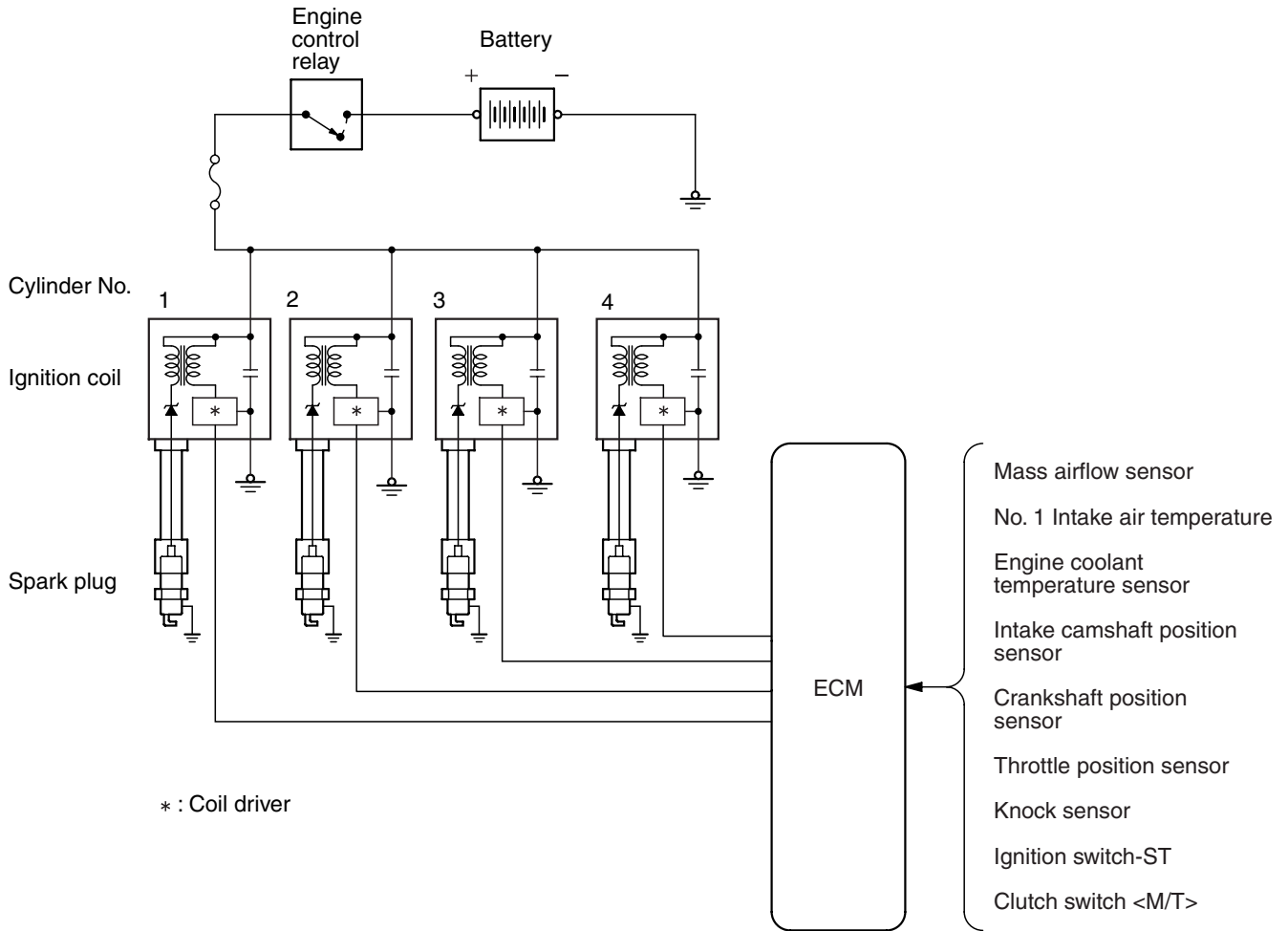

AK703692AD

GENERAL SPECIFICATIONS

M1163000200097

Item	Specification
Ignition Coil	
Type	Molded 4 coil
Spark Plugs	
NGK	ILKR8E6

SERVICE SPECIFICATIONS

M1163000300793

Item	Standard value	Limit
Spark plug gap mm (in)	0.5 -0.6 (0.020 -0.023)	0.75 (0.029)

## ON-VEHICLE SERVICE

## KNOCK CONTROL SYSTEM CHECK

M1163001800315

Check the knock sensor circuit if diagnostic trouble code, No. P0326, P0327 or P0328 is shown.

Refer to GROUP 13A, Multiport Fuel Injection (MFI) –Multiport Fuel Injection (MFI) Diagnosis –Diagnostic Trouble Code Chart [P.13A-44](#).

## IGNITION COIL CHECK

M1163001201059

## Required Special Tool:

MB991958: Scan Tool (M.U.T.-III Sub Assembly)

- MB991824: V.C.I.
- MB991827: M.U.T.-III USB Cable
- MB991910: M.U.T.-III Main Harness A

**⚠ CAUTION**

**To prevent damage to scan tool MB991958, always turn the ignition switch to the "LOCK" (OFF) position before connecting or disconnecting scan tool MB991958.**

*NOTE: It is impossible to carry out an easy check using a circuit tester because a diode and so on are integrated into the inside circuit of this ignition coil. Accordingly, check the ignition coil in the following procedure.*

1. Make sure the diagnosis codes are not stored using scan tool MB991958. If stored, record the code No. Carry out the troubleshooting for the stored codes and solve the problems even if not related to the ignition.
2. Disconnect the injector connectors on all of the cylinders.
3. Disconnect the ignition coil connector.
4. Remove the ignition coil and install a good spark plug to the ignition coil.
5. Connect the ignition coil connector.
6. Ground the side electrode of the spark plug and crank the engine.
7. Check that spark is produced between the electrodes of the spark plug.
8. If the spark plug has weak spark or no spark, carry out the same check using a good ignition coil. If there is strong spark on this check with a good ignition coil, it becomes clear there is a problem with the ignition coil. Replace the ignition coil with a new one. If there is no spark on this check with a good ignition coil, there is probably a problem with the ignition circuit. Check the ignition circuit.
9. Using scan tool MB991958, make sure whether the diagnosis codes are stored due to the check, or not. Except the codes stored in Step 1, clear the codes all together if they are present. And then, carry out the troubleshooting about the codes recorded.

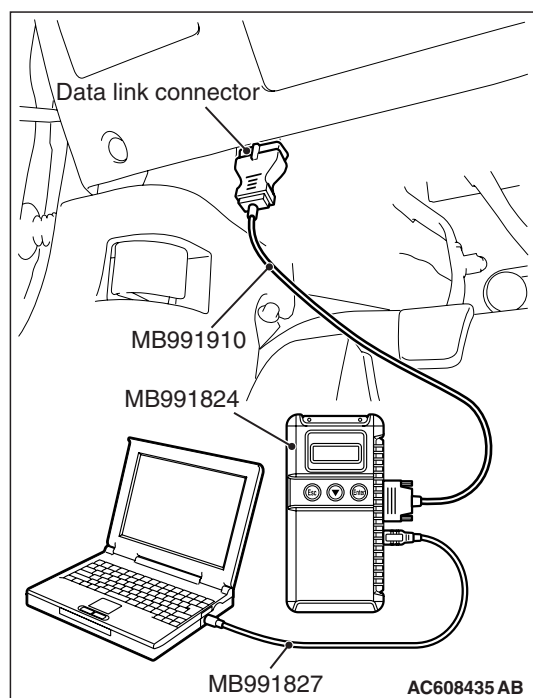

**⚠ CAUTION**

To prevent damage to scan tool MB991958, always turn the ignition switch to the "LOCK" (OFF) position before connecting or disconnecting scan tool MB991958.

10. Disconnect scan tool MB991958 to the data link connector.

**SPARK PLUG TEST**

M1163001500206

1. Remove the spark plug and connect to the ignition coil.

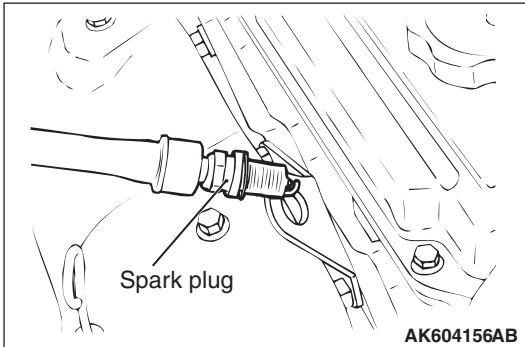

2. Ground the spark plug outer electrode (body), and crank the engine.

Check that there is an electrical discharge between the electrodes at this time.

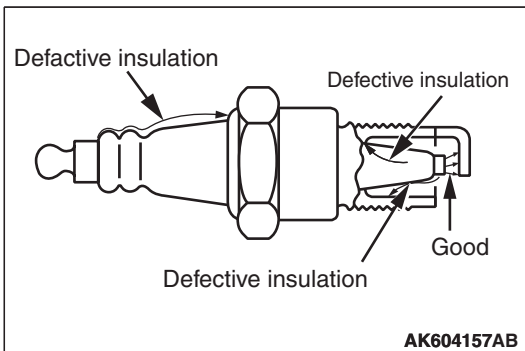

**SPARK PLUG CHECK AND CLEANING**

M1163004301646

**⚠ CAUTION**

- Never attempt to adjust the gap of the iridium plug.
- Do not attempt to clean the spark plug because it may result in damage to the electrode. However, if carbon deposits must be removed, using a sand blast type plug cleaner, complete the cleaning within 20 seconds to protect the electrode. Do not use a wire brush.

*NOTE: Obey the maintenance interval of the relevant vehicle for the spark plug replacement. If the plug gap and insulation resistance are normal, check the plug state and clean it if necessary.*

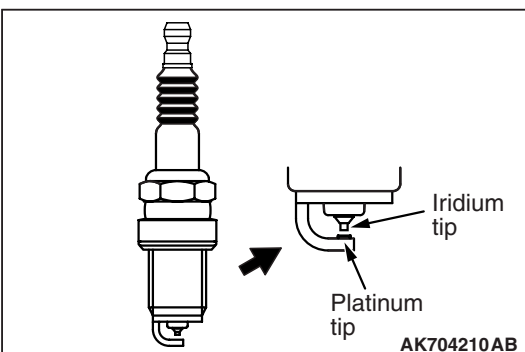

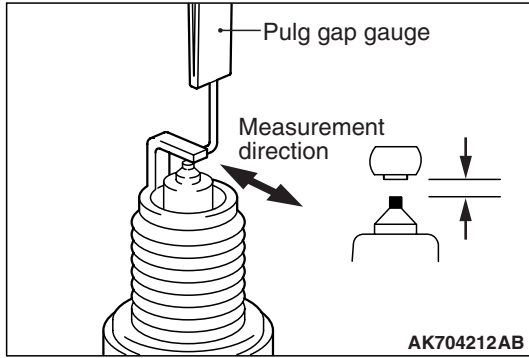

### SPARK PLUG GAP CHECK

Check the plug gap with the wire type plug gauge. Replace it if the limit is exceeded.

**Standard value: 0.5 –0.6 mm (0.020 –0.023 inch)**

**Limit: 0.75mm (0.029 inch)**

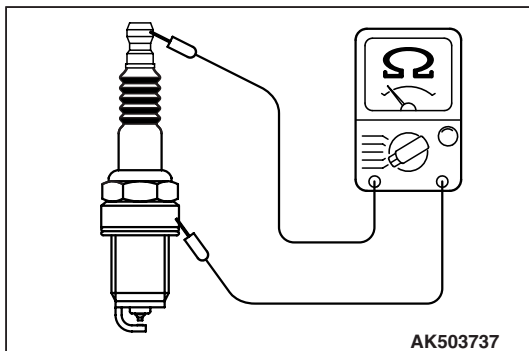

### SPARK PLUG INSULATION RESISTANCE CHECK

1. Measure the insulation resistance. If the insulation resistance of the spark plug is under the limited value, clean the plug within 20 seconds using a plug cleaner.
2. After cleaning, measure the insulation resistance again. Replace the plug unless it is within the limited value.

**Limit: Minimum 10 M $\Omega$**

### CAMSHAFT POSITION SENSOR CHECK

M1163004400792

Refer to GROUP 13A, Multiport Fuel Injection (MFI) –Multiport Fuel Injection (MFI) Diagnosis –Diagnostic Trouble Code Procedures –DTC P0340: Intake Camshaft Position Sensor Circuit [P.13A-377](#).

### CRANKSHAFT POSITION SENSOR CHECK

M1163004500841

Refer to GROUP 13A, Multiport Fuel Injection (MFI) –Multiport Fuel Injection (MFI) Diagnosis –Diagnostic Trouble Code Procedures –DTC P0335: Crankshaft Position Sensor Circuit [P.13A-367](#).

**IGNITION COIL  
REMOVAL AND INSTALLATION**

M1163004001441

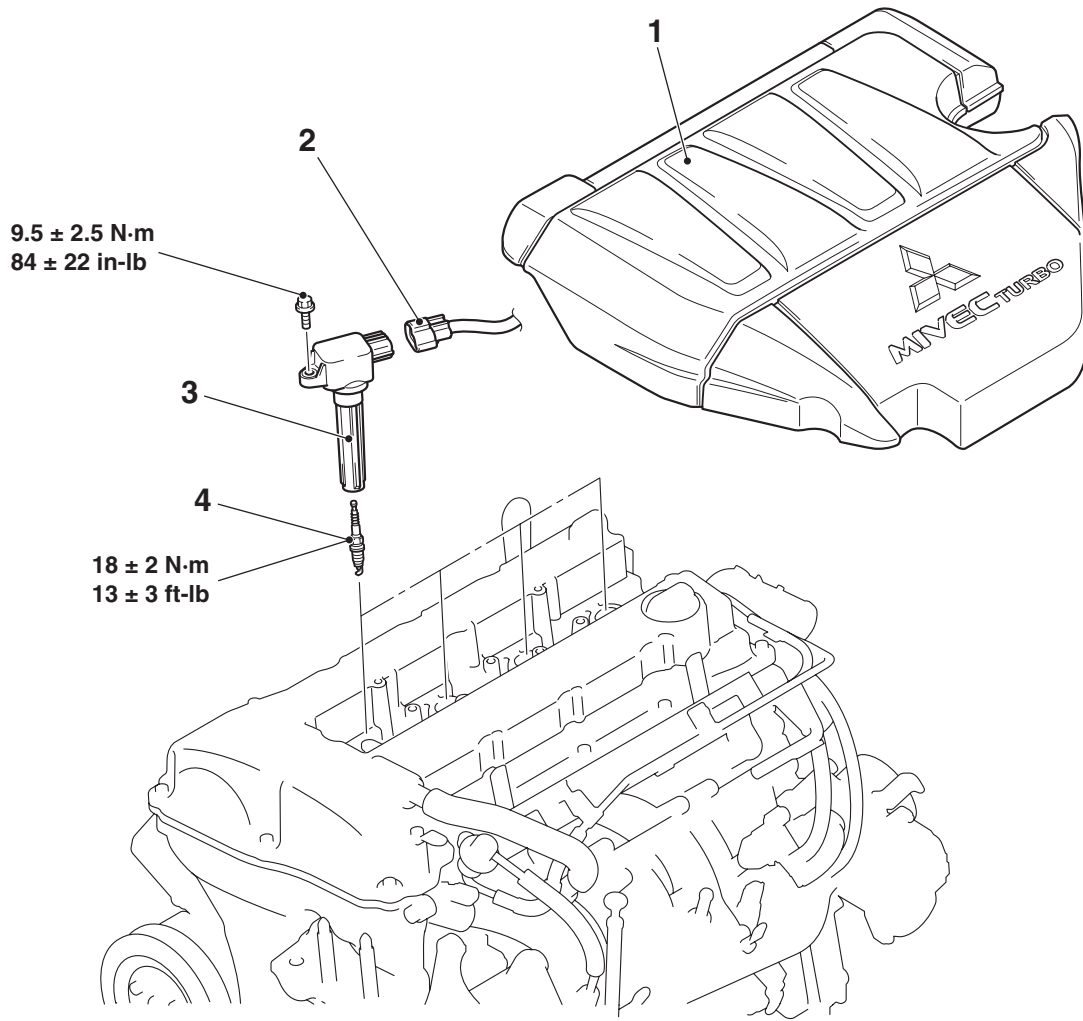

AC706231AC

**Removal steps**

1. Engine upper cover
2. Ignition coil connector connection

**Removal steps (Continued)**

3. Ignition coil
4. Spark plug

CAMSHAFT POSITION SENSOR  
REMOVAL AND INSTALLATION

M1163003401349

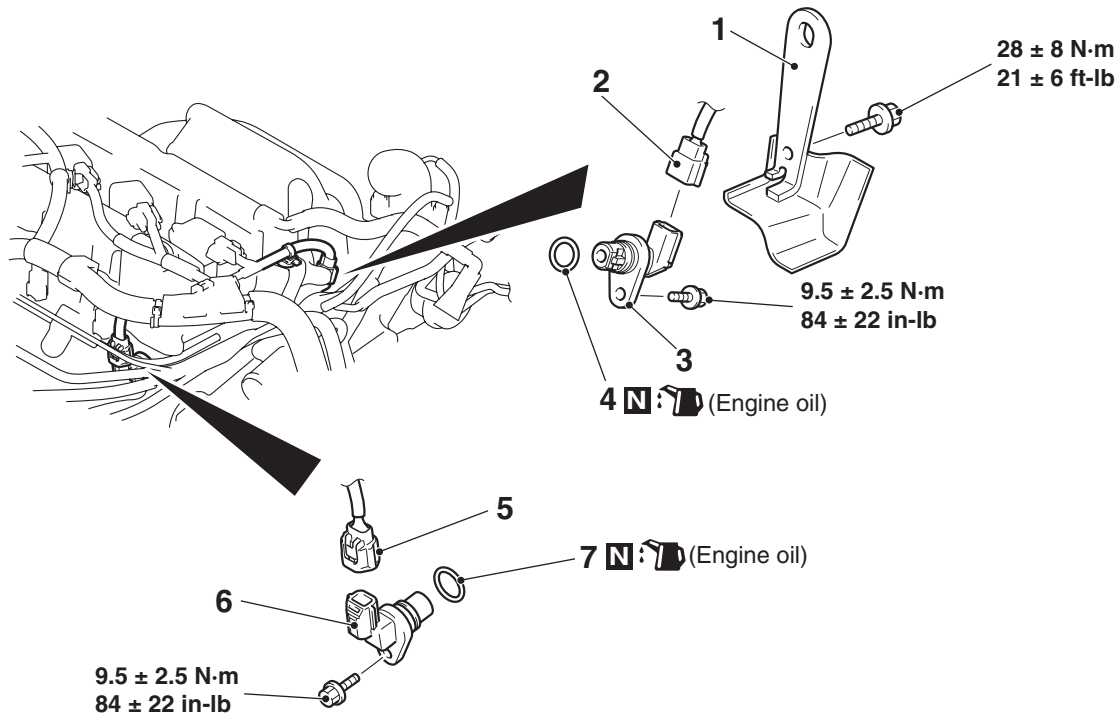

AC709301AB

**Exhaust camshaft position  
sensor removal steps**

1. Engine hanger
2. Exhaust camshaft position sensor connector connection
3. Camshaft position sensor
4. O-ring

**Intake camshaft position  
sensor removal steps**

5. Intake camshaft position sensor connector connection
6. Camshaft position sensor
7. O-ring



## CRANKSHAFT POSITION SENSOR

### REMOVAL AND INSTALLATION

M1163003500860

#### Pre-removal and post-installation operation

- Engine Room Under Cover Front A, B and Engine Room Under Cover Center Removal (Refer to GROUP 51, Under Cover [P.51-16](#)).

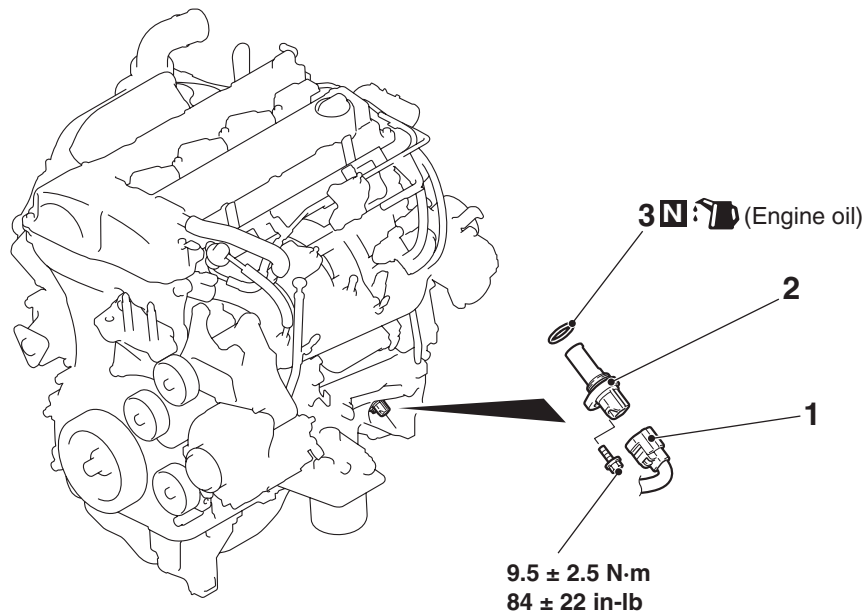

AC706620AC

#### Removal steps

1. Crankshaft position sensor connector connection

#### Removal steps (Continued)

2. Crankshaft position sensor
3. O-ring

## KNOCK SENSOR

## REMOVAL AND INSTALLATION

M1163002801838

**CAUTION**

When the knock sensor is replaced, initialize the learned value using scan tool (Refer to GROUP 00, Precautions before Service –and Initialization Procedure of MFI Engine Learned Value P.00-31).

**Pre-removal and post-installation operation**

- Engine Room Under Cover Front A, B and Engine Room Under Cover Center Removal (Refer to GROUP 51, Under Cover P.51-16).

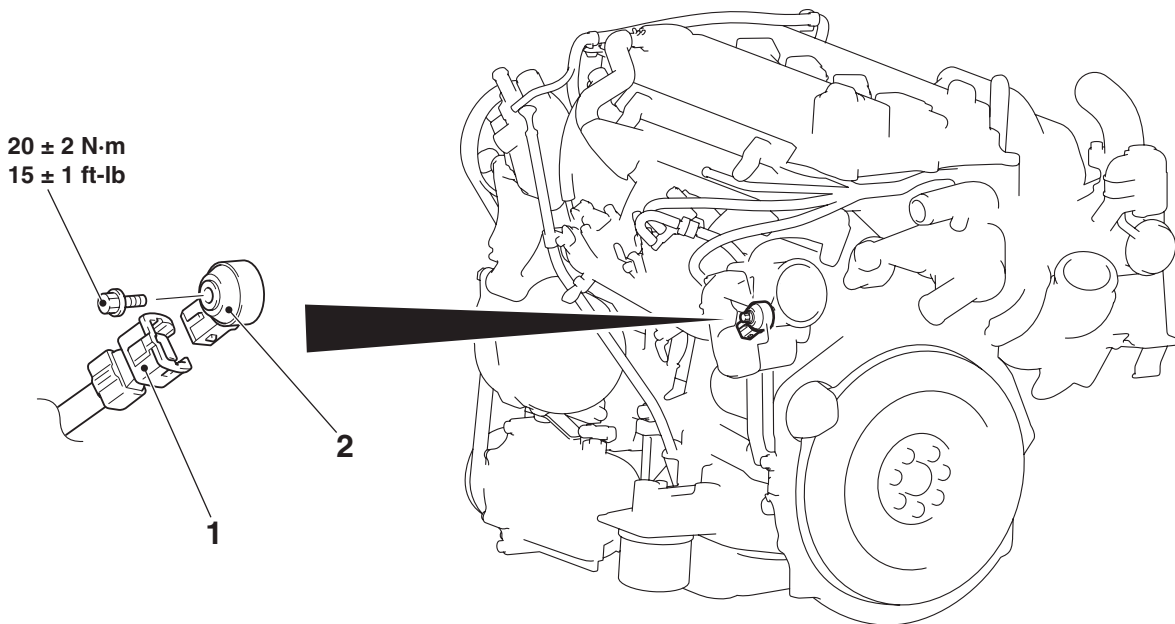

AC706621 AC

**Removal steps**

1. Knock sensor connector connection
- >>A<< 2. Knock sensor

**INSTALLATION SERVICE POINT****>>A<< KNOCK SENSOR INSTALLATION**

Set the connector of the knock sensor to the position shown in the figure, and tighten it to the specified torque.

**Tightening torque: 20 ± 2 N· m (15 ± 1 ft-lb)**

