GROUP 42B

KEYLESS OPERATION SYSTEM (KOS)

CONTENTS

GENERAL INFORMATION	42B-2	ENGINE STARTING FUNCTION (IMMOBILIZER FUNCTION)	42B-17
SYSTEM OPERATION	42B-8	TIRE PRESSURE MONITORING SYSTEM (TPMS) FUNCTION	42B-21
DOOR ENTRY FUNCTION	42B-8	WARNINGS/ALARMS	42B-23
KEYLESS ENTRY FUNCTION	42B-13		
		CUSTOMIZATION FUNCTION	42B-28

GENERAL INFORMATION

M2421000100276

NOTE: In this manual, F.A.S.T.-key (Free-hand Advanced Security Transmitter) is described as Keyless Operation System (KOS). (KOS is indicated as F.A.S.T. in the scan tool display.)

The keyless operation system (KOS) enables the driver to unlock all the doors and the trunk lid by just pulling the front door outside handle or operating the trunk lid open switch, without taking the key out from his/her pocket or bag when he/she is carrying a keyless operation key that is registered to the vehicle's KOS-ECU. (When the driver's front door outside handle is operated, only the driver's door is unlocked.) KOS also allows the driver to lock all the doors by pressing the lock switch on the front door outside handle (door entry function), and start the engine without using the conventional mechanical key (engine start function). Moreover, KOS incorporates the keyless entry function with which, like the conventional keyless entry system, a driver can perform the remote operation (opening/closing of all the doors, opening of the trunk lid, warning function to warn a person who intends to damage the vehicle^{*}) by operating the lock/unlock button, trunk lid button, and panic button on the keyless operation key. The system also incorporates the immobilizer function that prohibits the starting of engine by using an unauthorized key as well as the tire pressure monitoring system (TPMS) that issues a warning to a driver by illuminating or flashing the warning light if an abnormality to the tire pressure or the system error is detected. KOS has the following features:

- Each vehicle is provided with two keyless operation keys, and up to four keyless operation keys can be equipped.
- The keyless operation key also incorporates an indicator light that enables the driver to check if the signal is transmitted correctly or if the battery in the key is discharged. (Refer to [P.42B-13](#).)
- The keyless operation key incorporates an emergency key to lock/unlock the front doors when the battery in the keyless operation key is discharged or the keyless operation system is not working normally. Also by using it simultaneously with the keyless operation key (insert the emergency key into the keyless operation key in the inverted direction), the engine can be started. (Refer to [P.42B-17](#).)

NOTE: If the immobilizer related system failure occurs, the engine may not start.

- The driver can customize KOS; enabling the door entry/engine start function, disabling the door entry/engine start function, enabling the door locking/unlocking function only, or enabling the engine starting function only. (Refer to [P.42B-28](#).)

NOTE: ^{}: Horn sounds, and headlights and taillights flash.*

CONSTRUCTION DIAGRAM

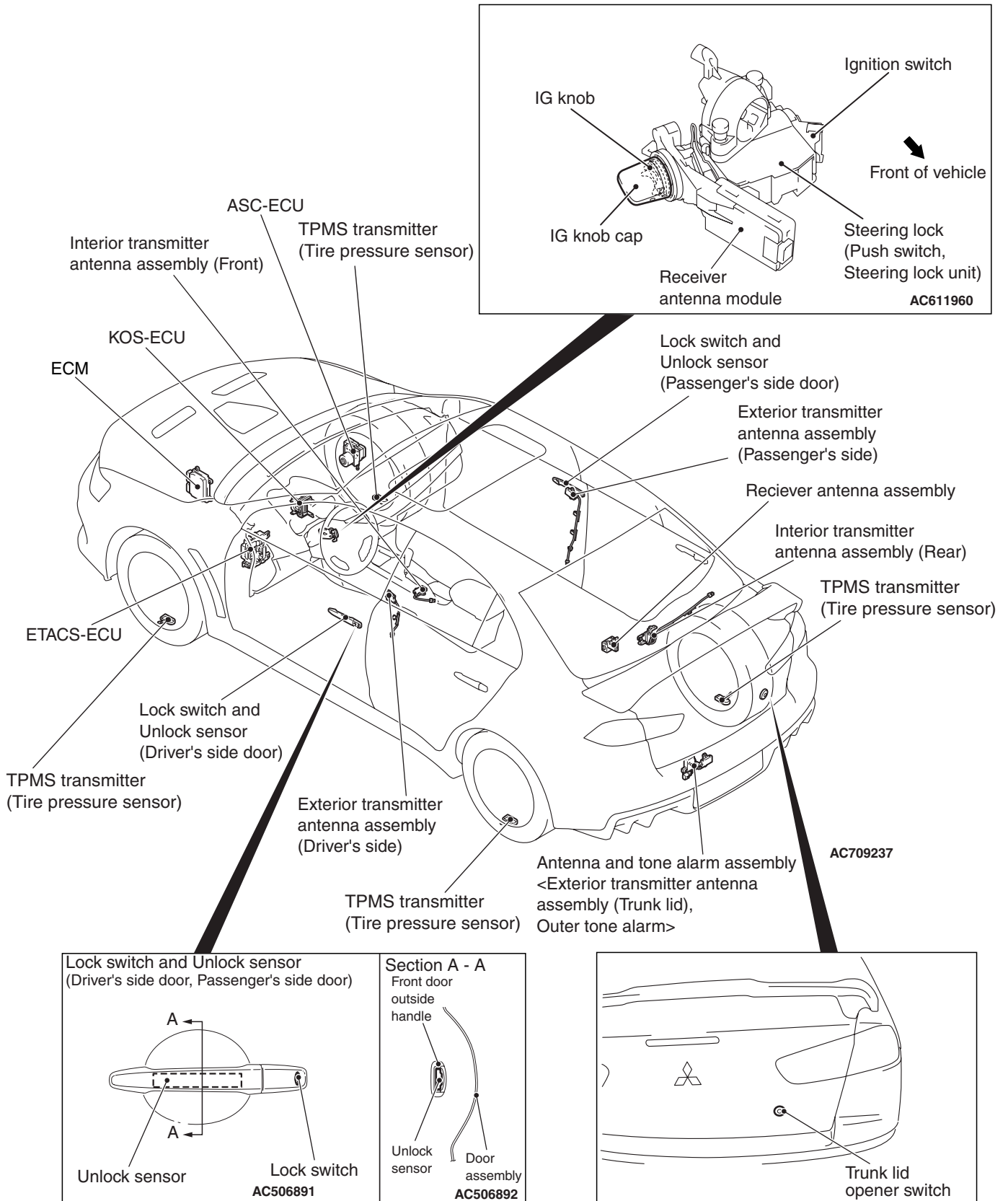

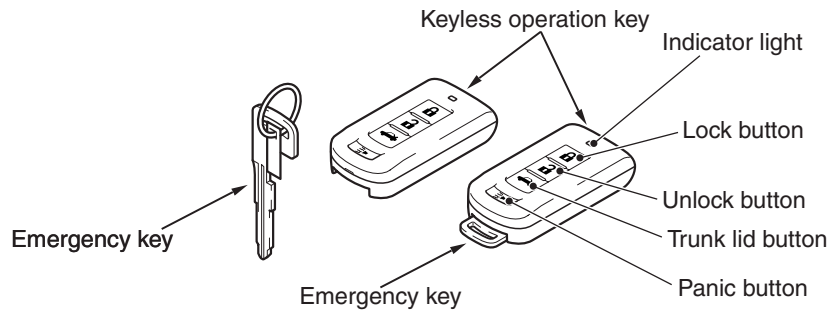
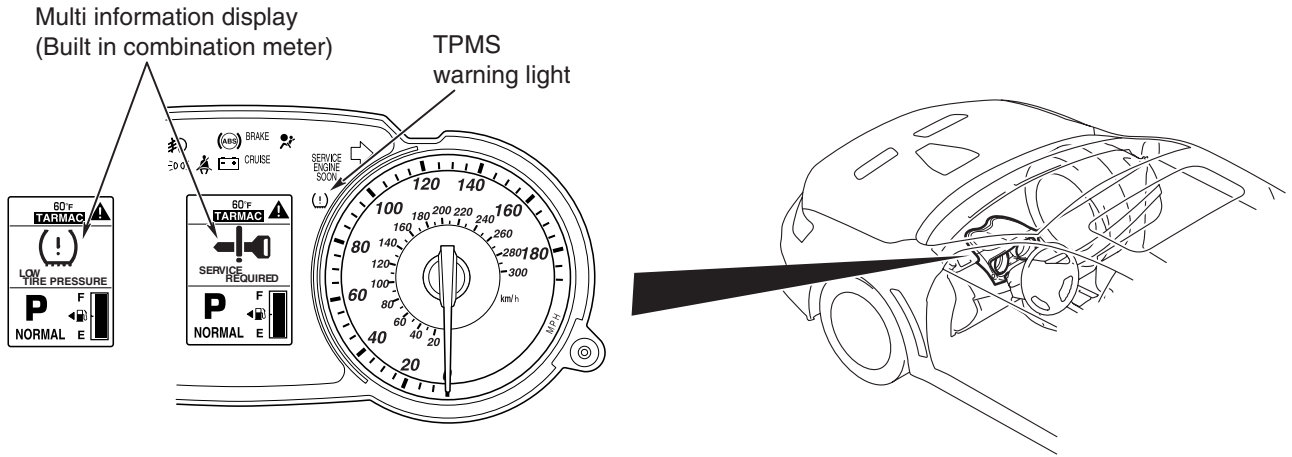

Main components and functions

Parts name		Functional description
KOS-ECU		<p>Controls KOS by using the following inputs/outputs and communications.</p> <ul style="list-style-type: none"> • Input from the unlock sensor and lock switch on each door, input from the push switch on the IG knob • Communications with ETACS-ECU, ECM or ASC-ECU and combination meter via CAN • Wire communication with the steering lock unit • Wireless communication with the keyless operation key via the receiver antenna module, receiver antenna assembly and interior/exterior transmitter antennas • Output to the outer tone alarm
Steering lock (incorporates push switch and steering lock unit)		The steering lock has two unlocking mechanisms; a mechanical mechanism that uses an emergency key and an electrical mechanism. In the electrical unlocking mechanism, the steering lock communicates with KOS-ECU via wire, and when requested by KOS-ECU, the steering lock unlocks for two seconds.
Keyless operation key (incorporates emergency key)		<ul style="list-style-type: none"> • The keyless operation key receives signals sent from each interior/exterior transmitter antenna, certifies the keyless operation key ID code, calculates the key ID, and sends the reply data signal to KOS-ECU via the receiver antenna assembly. The lock button, unlock button, and trunk lid button operations of keyless operation key transmit signals to KOS-ECU via the receiver antenna assembly. • If two or more keyless operation keys registered in KOS-ECU respond at the same time, their signals would interfere. To avoid this interference, each signal from KOS-ECU is given the priority^{*1} data, and the keyless operation keys respond in accordance with this priority.
Lock switch	Driver's door	Locks all the doors when a driver carrying the keyless operation key presses the lock switch on the front door outside handle.
	Front passenger's door	
Unlock sensor	Driver's door	The unlock sensors incorporated in the driver's front door outside handles unlock driver's the door when a driver carrying the keyless operation key pulls the driver's door outside handle.
	Front passenger's door	The unlock sensors incorporated in the passenger's front door outside handles unlock all the doors when a driver carrying the keyless operation key pulls the front door outside handle.
Trunk lid opener switch		<p>By pressing the trunk lid opener switch on the trunk lid while he/she is carrying the keyless operation key, the trunk lid is unlocked.</p> <p><i>NOTE: With the locking of trunk lid, the locking is performed mechanically when the trunk lid is closed.</i></p>
Exterior transmitter antenna assembly	Driver's side	Converts the data output from KOS-ECU via wire into a signal, and sends it to the keyless operation key. (For the transmission area, refer to Operation Manual – Door Entry Function P.42B-8.)
	Front passenger's side	

Parts name		Functional description
Interior transmitter antenna assembly	Front	Converts the data output from KOS-ECU via wire into a signal, and sends it to the keyless operation key. (For the transmission area, refer to Operation Manual – Engine Start Function P.42B-17.)
	Rear	
Antenna & tone alarm assembly	Exterior transmitter antenna assembly (trunk lid)	Converts the data output from KOS-ECU via wire into a signal, and sends it to the keyless operation key. (For the transmission area, refer to Operation Manual – Door Entry Function P.42B-8.)
	Outer tone alarm	The outer tone alarm sounds when: <ul style="list-style-type: none"> • The doors are locked or unlocked by the door entry function. • The lock switch on the keyless operation switch is pressed when the IG knob is in the "LOCK" (OFF) position and the push switch is in other than the "ON" position. • The lock switch is pressed on the keyless operation key from inside the car. • The lock switch on the keyless operation key is pressed when the door is ajar.
Receiver antenna module		Receives the keyless operation key ID data which is necessary for the engine start using the emergency key, and then sends the data to KOS-ECU.
Receiver antenna assembly		Receives the operation signals from the lock/unlock buttons, trunk lid button, and panic button on the keyless operation key as well as the keyless operation key ID data which is necessary for engine start and the tire pressure signal from the TPMS transmitter. Then, sends the data to KOS-ECU.
TPMS transmitter		Measure tire pressure directly, then send radio frequency signal to receiver antenna assembly.
Combination meter (Multi information display, TPMS warning light)		Communicates with KOS-ECU via CAN. Receives the warning request or warning information from KOS-ECU, activates* ² the warning light. Warning symbol and message is additionally displayed on the multi information display
ETACS-ECU		Communicates with KOS-ECU via CAN. By the door lock/unlock request, trunk open request, or panic alarm request from KOS-ECU, ETACS-ECU outputs the lock/unlock signal, trunk open signal, or panic alarm signal. When the door lock/unlock signal is output, ETACS-ECU flashes or illuminates the turn signal light and dome light to notify that the lock/unlock operation is performed.
ECM		Communicates with KOS-ECU via CAN. Permits/inhibits the engine starting and controls the engine operation. Send atmospheric pressure data.
ASC-ECU		Communicates with KOS-ECU via CAN. Sends the vehicle speed data.

NOTE: *¹: When registering the keyless operation keys, KOS-ECU numbers each key (1 to 4) in the order they are registered (initial priority). This priority is renewed each time the doors are locked/unlocked and the IG knob is pressed. For example, when only keys 1 and 3 have responded to the signal sent from

KOS-ECU, the new priority of the keys would be 1-3-2-4. When keys 3 and 4 have responded, then the priority of the keys becomes 3-4-1-2.

NOTE: *²: Illuminates for tire pressure warning. Flashes for about 1 minute and then continuously illuminated for TPMS malfunction warning.

System configuration

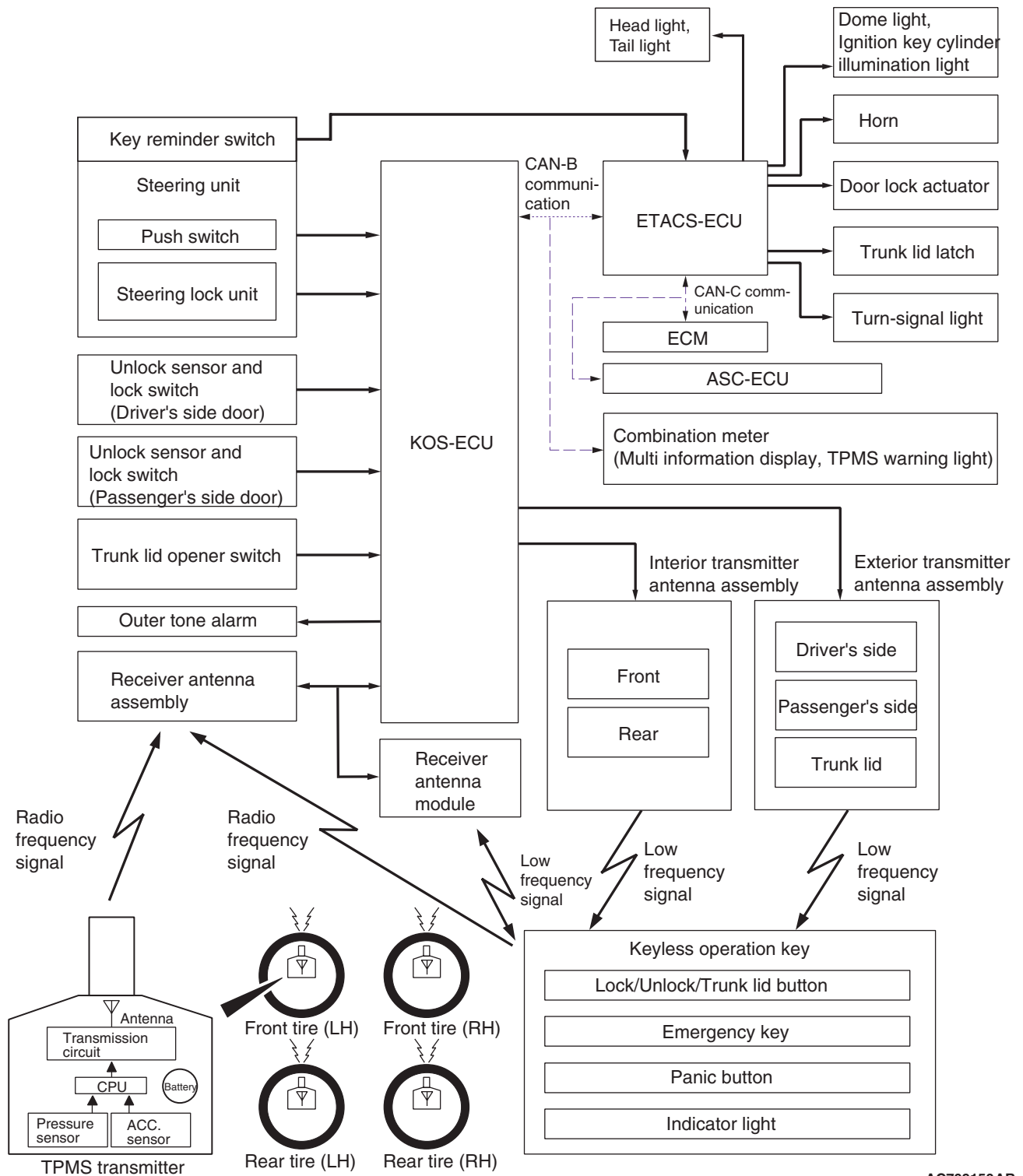

AC709150AB

SYSTEM OPERATION

DOOR ENTRY FUNCTION

M2421009100228

DESCRIPTION OF CONSTRUCTION AND OPERATION

<Vehicles outside area>

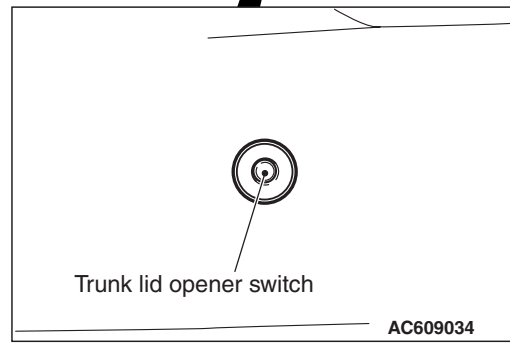
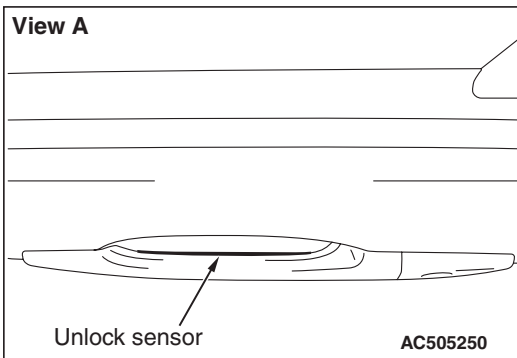
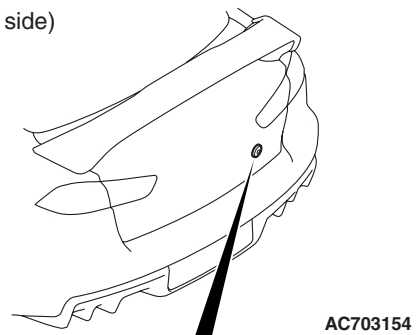
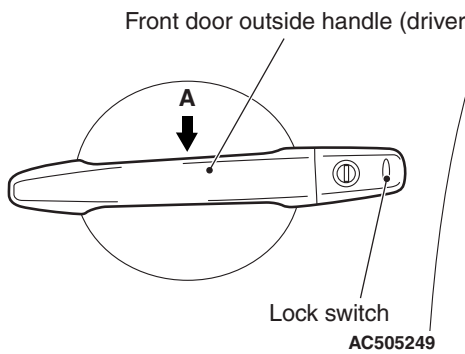
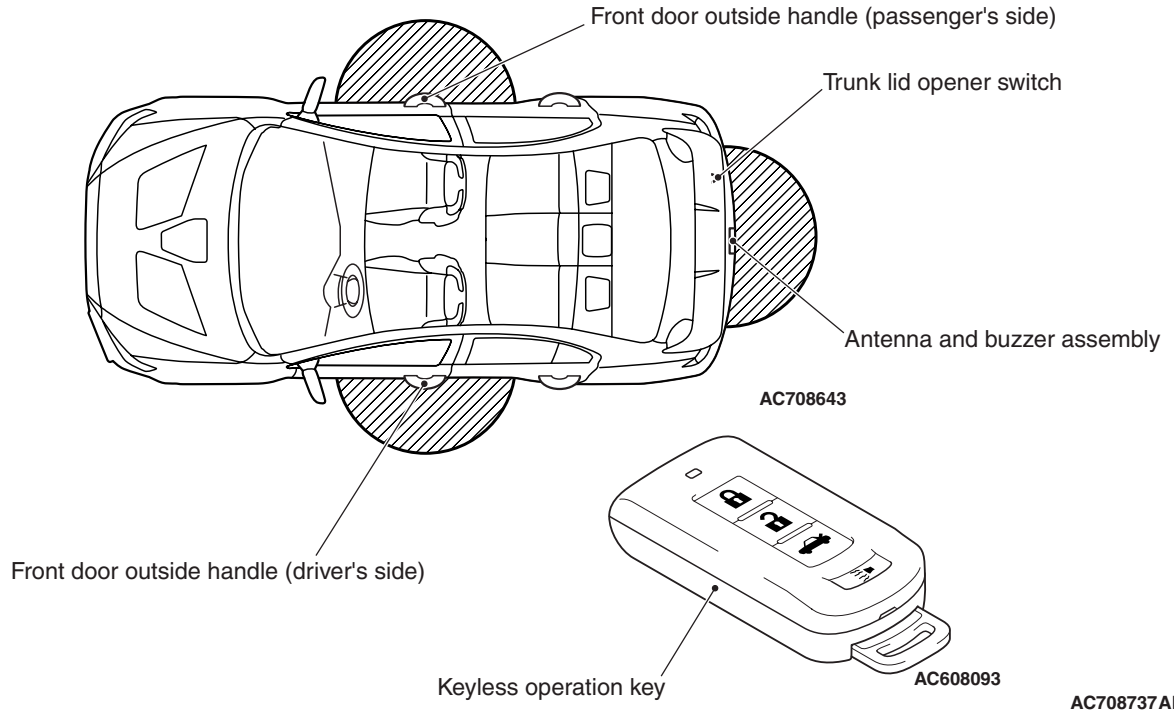

AC705753AC

When a driver carrying a keyless operation key presses the lock switch and the unlock sensor (door outside handle) on the driver's/passenger's door outside handle or the trunk lid opener switch, the keyless operation key and KOS-ECU communicate to certify* the keyless operation key. When KOS-ECU certifies the registered keyless operation key within 70 cm (28 inches) in radius from the outer side of the vehicle, it requests ETACS-ECU to lock/unlock the doors (Even within this range, the key may not be certified when it is positioned too high or too low).

NOTE: *: In the communication for certification of the keyless operation key, KOS-ECU judges if the keyless operation key ID (specified to keyless operation key) contained in the response data from the keyless operation key coincides with the ID that has been stored in ECU by registration operation. The keyless operation key sends the response to KOS-ECU only when the KOS ID (specific to KOS-ECU) contained in the received data coincided with the stored ID. In the beginning of the communication for certification,

KOS-ECU creates an encrypted code calculation factor in random number, and sends it to the keyless operation key together with the transmit data. The keyless operation key calculates the code by using the received factor, and sends the result to KOS-ECU together with the response data. KOS-ECU determines that the communication is established only when the code calculation results of both parties coincided.

UNLOCKING OPERATION OF DOOR ENTRY FUNCTION

The keyless operation key and KOS-ECU communicate to certify the keyless operation key when the unlock sensor on the driver-side/front passenger-side door outside handle or the trunk lid opener switch is turned ON. When KOS-ECU certifies the registered keyless operation key on the outer side of the vehicle, it requests ETACS-ECU to unlock the doors.

CONTROL OF UNLOCKING OPERATION

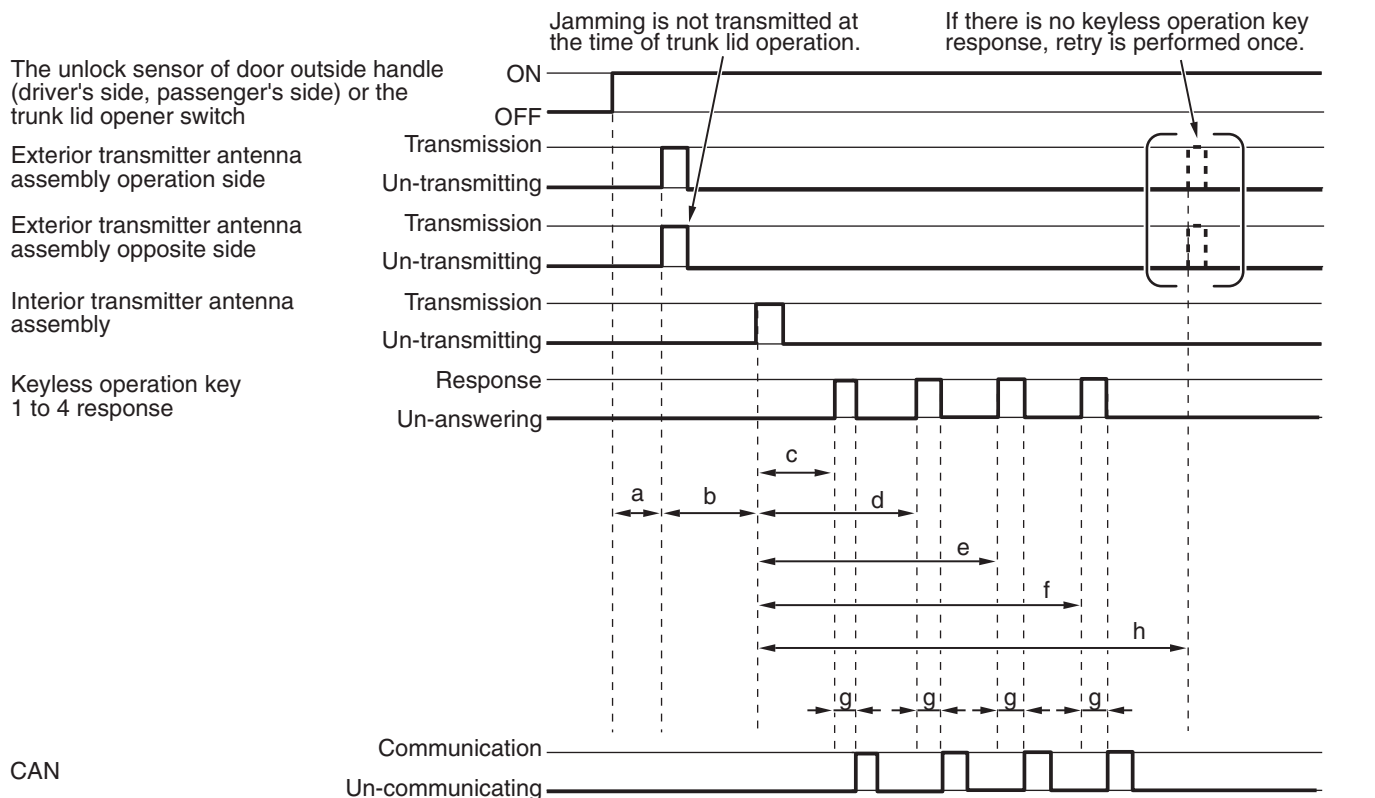

- a: Exterior data transmitting start: 0.015 to 0.04 sec
- b: Interior data transmitting start: 0.03 to 0.05 sec
- c: Keyless operation key 1 response time of onset 0.035 to 0.06 sec
- d: Keyless operation key 2 response time of onset 0.08 to 0.115 sec

- e: Keyless operation key 3 response time of onset 0.135 to 0.18 sec
- d: Keyless operation key 2 response time of onset 0.205 to 0.26 sec
- g: CAN communication time of onset: to 0.3 sec
- h: Retry time: It is variable by the registration number (at the time of 4 pieces registration 3.1 sec).

AC500829AD

1. When KOS-ECU detects that the unlock sensor on the driver-side/front passenger-side door outside handle or the trunk lid opener switch is turned ON, it transmits the exterior data from the exterior transmitter antenna assembly on the operation side. At the same time, KOS-ECU transmits the interfering radio wave* (reversal code) from the exterior transmitter antenna assembly on the other side (The interfering radio wave will be transmitted from the front passenger-side antenna assembly when the driver-side door outside handle is operated, and vice versa. It will not be transmitted when the trunk lid opener switch is operated).
*NOTE: *: The interfering radio wave is transmitted to disable the door lock operation by a person without the keyless operation key while a user with the keyless operation key is operating the door lock from the opposite side of the vehicle.*
2. After the exterior data is transmitted from the exterior transmitter antenna assembly, the interior data is transmitted from the interior transmitter antenna assembly (front, rear).
3. For the specified time period (varies with the number of the keyless operation keys registered in KOS-ECU), KOS-ECU monitors the response from the keyless operation key that meets the unlock conditions.
 - When the keyless operation key receives the exterior data only, KOS-ECU transmits the unlock request (request to unlock the applicable position) to ETACS-ECU.
 - When KOS-ECU received no response that enables the unlocking after the specified time period has passed, it performs the retry cycle once (When no response after the retry, KOS-ECU terminates the unlocking operation).

UNLOCKING OPERATION INHIBITION TIME

Considering the customer pulls the door outer handle to make sure the doors are locked, unlocking operation is inhibited for three seconds after the doors are locked by the lock switches on the driver-side/front passenger-side door outside handle or on the trunk lid opener switch. This duration can be selected from zero, three seconds, and five seconds, and can be switched using a customization function (Refer to P.42B-28). The initial setting at factory is 3 seconds.

UNLOCKING OPERATION INHIBITION CONDITIONS

The door unlocking operation is inhibited when:

- The emergency key is in the ignition switch.
- The push switch in the steering lock is ON.
- The IG knob is in other than LOCK (OFF) position.
- During the unlocking operation inhibition time

LOCKING OPERATION OF DOOR ENTRY FUNCTION

The keyless operation key and KOS-ECU communicate to certify the keyless operation key when the lock switch on the driver-side/front passenger-side door outside handle is turned ON. When KOS-ECU certifies the registered keyless operation key only on the outer side of the vehicle, it requests ETACS-ECU to lock all the doors.

CONTROL OF LOCKING OPERATION

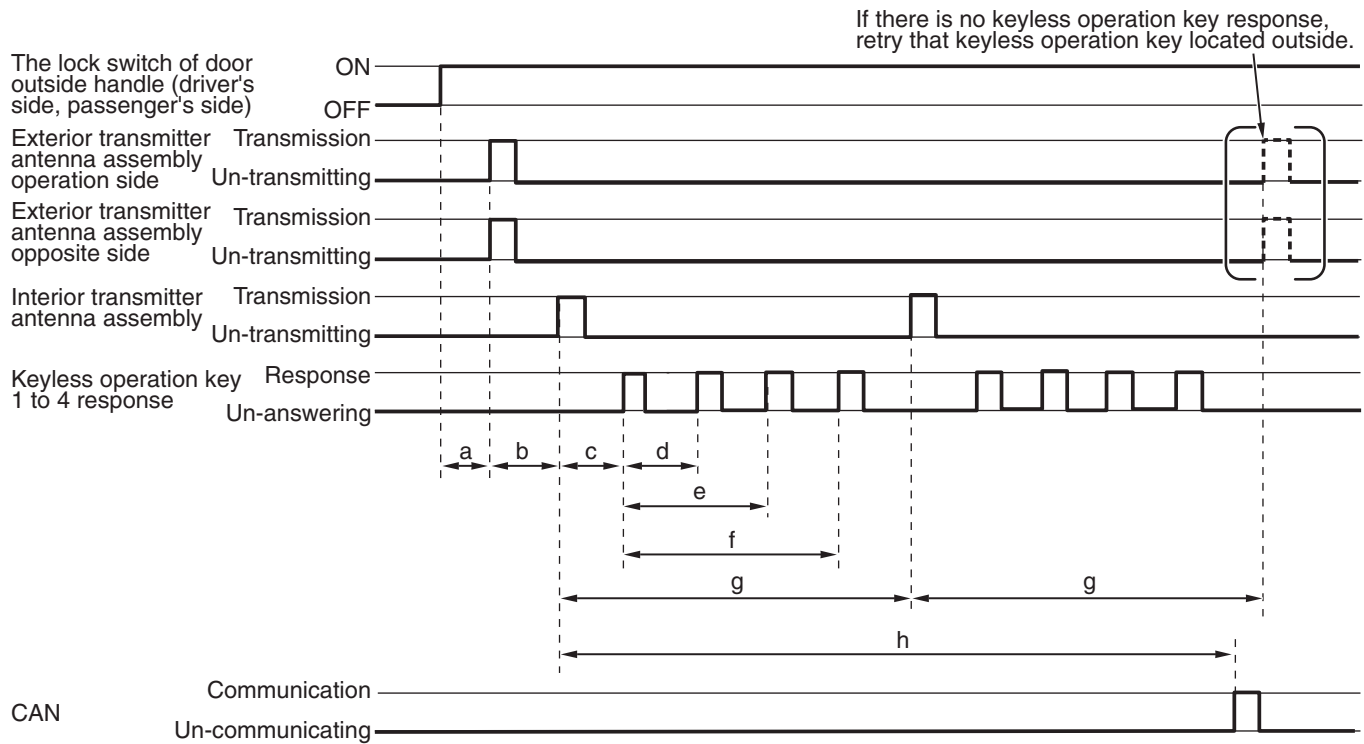

AC607100AB

1. When KOS-ECU detects that the lock switch on the driver-side/front passenger-side door outside handle is turned ON, it transmits the exterior data from the exterior transmitter antenna assembly on the operation side. At the same time, KOS-ECU transmits the interfering radio wave (reversal code) from the exterior transmitter antenna assembly on the other side. (The interfering radio wave will be transmitted from the front passenger-side antenna assembly when the driver-side door outside handle is operated, and vice versa.)
2. After the exterior data is transmitted from the exterior transmitter antenna assembly, the interior data is transmitted from the interior transmitter antenna assembly (front, rear).
3. After the specified time period (varies with the number of the keyless operation keys registered in KOS-ECU) has passed, confirm that there is no keyless operation key in the interior.
 - When KOS-ECU receives the response from the keyless operation keys that received the interior data, KOS-ECU cancels the locking operation.
4. KOS-ECU transmits the interior data from the interior transmitter antenna assembly (Front).
5. After the specified time period (varies with the number of the keyless operation keys registered in KOS-ECU) has passed, confirm that the lock conditions are met.
 - When KOS-ECU receives the response from the keyless operation keys that received the interior data, KOS-ECU cancels the locking operation.
 - When all the responding keyless operation keys receive the exterior data only, KOS-ECU transmits the lock request to ETACS-ECU.
 - If there is no response from the keyless operation keys, perform step 6 once.

6. KOS-ECU transmits the exterior data from the exterior transmitter antenna assembly on the operation side. At the same time, KOS-ECU transmits the interfering radio wave (reversal code) from the exterior transmitter antenna assembly on the other side. (The interfering radio wave will be transmitted from the front passenger-side antenna assembly when the driver-side door outside handle is operated, and vice versa.)
7. After the specified time period (varies with the number of the keyless operation keys registered in KOS-ECU) has passed, confirm that the lock conditions are met.
 - When the responded keyless operation keys after the retry receives the exterior data only, KOS-ECU transmits the lock request (request to lock the actuated position) to ETACS-ECU.

LOCKING OPERATION INHIBITION CONDITIONS

In the following cases, the door locking operation is inhibited.

- Any door is open/ajar (door switch is ON). (including door ajar)
- The emergency key is in the ignition switch.
- The push switch in the steering lock is ON.
- The IG knob is in other than LOCK (OFF) position.

ANSWERBACK FUNCTIONS

When KOS-ECU sends a signal to ETACS-ECU, ETACS-ECU outputs the lock/unlock signal and activates the hazard warning light and the outer tone alarm to notify the driver the doors are locked/unlocked.

Item	Lock signal received	Unlock signal received
ETACS-ECU	Lock signal output	Unlock signal output
Hazard warning light	Flashes once	Flashes twice
Outer tone alarm	Sounds once (initial setting) or none	Sounds twice (initial setting) or none

KOS TIMER LOCK FUNCTION

When none of the doors are opened within 30 seconds after the doors are unlocked by KOS, ETACS-ECU automatically outputs the door lock signal to lock the doors. This function prevents the doors from being unlocked accidentally.

KEYLESS ENTRY FUNCTION

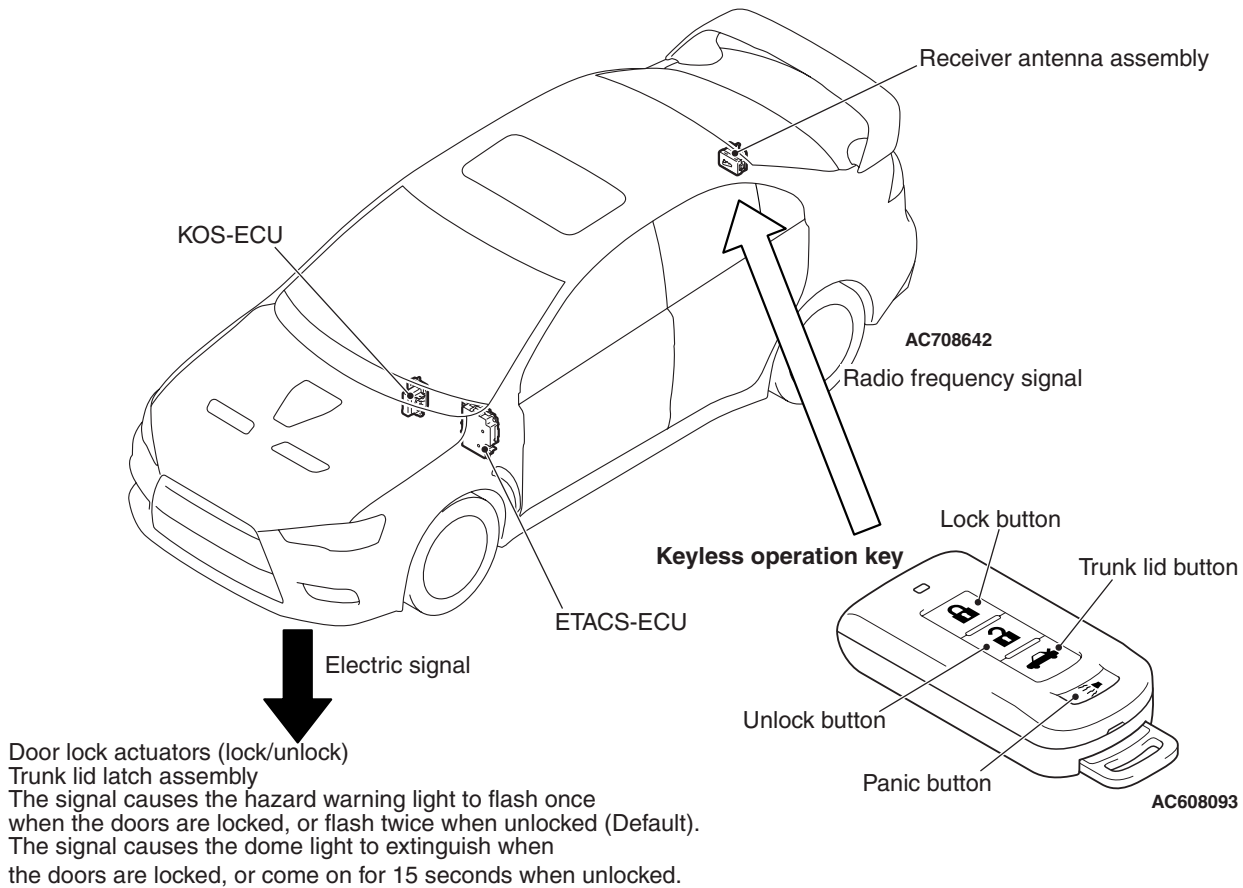

AC708674AB

This keyless entry function has the following features: A keyless entry system enables locking and unlocking of all doors, the trunk lid from 12m (39.4 feet) away from the vehicle. The following features are also available.

- A four-knob type keyless operation key with lock, unlock, trunk lid and panic buttons.
- The receiver antenna assembly incorporates a receiver and a receiving antenna.

- Up to four key ID can be registered using scan tool MB991958 (M.U.T.-III sub-assembly).
- Answerback functions
NOTE: The answerback function can be changed using a customization function (Refer to P.42B-28).
- Keyless entry timer lock
NOTE: Timer of the keyless entry timer lock can be changed using a customization function (Refer to P.42B-28).

DESCRIPTION OF CONSTRUCTION AND OPERATION

KEYLESS OPERATION KEY

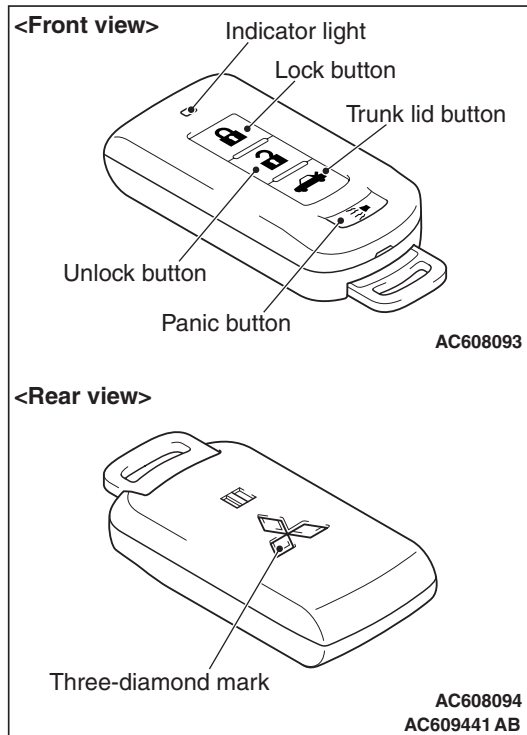

- The keyless operation key is integrated into the master key. The four-knob button is adopted, and the specific encrypted code is transmitted as radio wave signal.
- A brilliant silver three-diamond mark is stamped on the back side of the key grip to improve appearance.
- An indicator light, which illuminates when signals are sent, is added on the key grip. This indicator light informs you of the signal transmission status and warns you of flat battery.
- A signal transmission circuit (printed circuit) and a battery are housed in one case. The case is housed in the key grip, thus improving resistance to water ingress.
- A coin type battery, CR2032 is used in the keyless operation key.
- Using a customization feature, the keyless operation key operation can be changed (Refer to P.42B-28).
- The keyless operation key button operation allows the system to operate as follows:

KEYLESS OPERATION SYSTEM OPERATION TABLE (DEFAULT)

Operation of keyless operation key		System operation
Lock button	Press once	Lock all doors
Unlock button	Press once	Unlock the driver's door
	Press twice	Unlock all doors
Trunk lid button	Press twice (press once, and then press again within 5 seconds)	Open the trunk lid
Panic alarm system	Panic button	Press once (press and hold for 1 second).
	Lock button, unlock button, trunk lid button or panic button	Press again
		Starts the panic alarm (headlights flash and horn honks for three minutes)
		Stops the panic alarm in progress

ENCRYPTED CODE

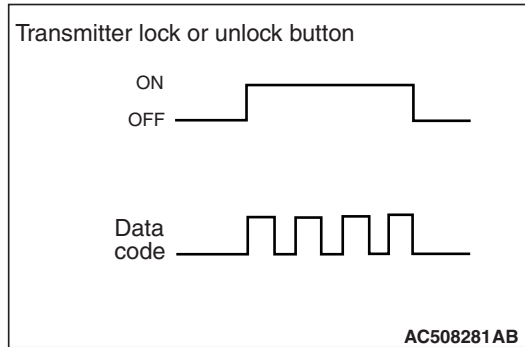

Four data codes are transmitted when a switch is operated once. The encrypted code for user identification is a combination of 0 and 1, and more than 1 million different combinations are available. To prevent theft by copying signal codes, the data code includes a rolling code with the encrypted code. The rolling code changes each time a signal is sent.

RECEIVER

The receiver is incorporated into the receiver antenna assembly together with the receiving antenna. It sends the signal the antenna received from the keyless operation key to KOS-ECU. KOS-ECU compares this signal with the ID code registered in it, and when they coincided, a signal is output from ETACS-ECU. By connecting scan tool MB991958 (M.U.T.-III sub-assembly) to the data link connector, up to four encrypted codes of keyless operation keys can be registered.

NOTE: 1A keyless operation key can be added without using the scan tool. <USA only>

FUNCTION FOR CONFIRMING RECEIVER ANTENNA ASSEMBLY OUTPUT AND OPERATION

When the KOS-ECU receives an electric wave signal of the identification code stored in the receiver antenna assembly, the KOS-ECU outputs LOCK/UNLOCK signal to the ETACS-ECU and informs the driver of the keyless entry system operation by flashing the light and blowing horn (Answerback). The initial setting at factory for the answerback function is as the following table. Using a customization feature, the answerback function can be changed (Refer to [P.42B-28](#)).

FUNCTION TABLE FOR CONFIRMING KEYLESS ENTRY OPERATION (DEFAULT)

Item	Operation	
	Doors locked	Doors unlocked
ETACS-ECU (receiver antenna assembly)	Sends lock signal	Sends unlock signal
Dome light	Flashes once	Illuminates for 15 seconds
Turn-signal lights (RH and LH)	Flashes once	Flashes twice
Horn	Sounds once if doors are already locked	–

KEYLESS ENTRY HAZARD LIGHT ANSWERBACK FUNCTION

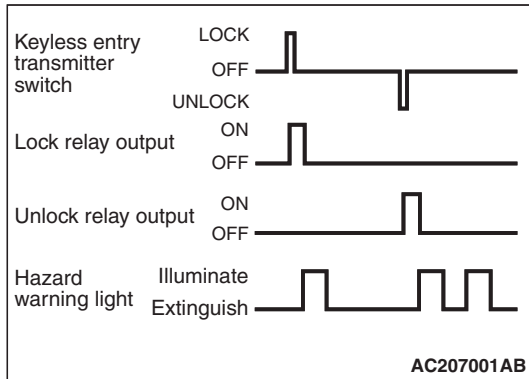

The hazard answerback function that allows checking the lock/unlock state of the door easily even in the daytime is installed. When the LOCK signal from the keyless operation key is input to ETACS-ECU, all doors are locked and the hazard warning light flashes once. When UNLOCK signal is input, all doors are unlocked and the hazard warning light flashes twice.

KEYLESS ENTRY DOME LIGHT ANSWERBACK FUNCTION

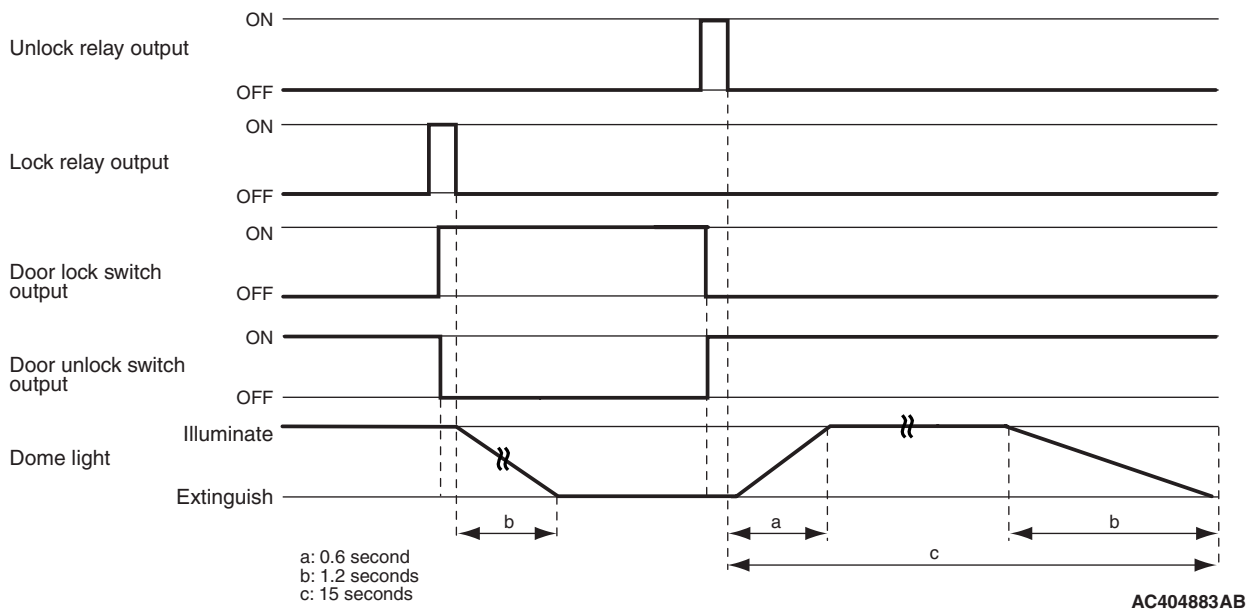

When LOCK signal from the keyless operation key is input to the ETACS-ECU via receiver antenna assembly, all doors are locked and the dome light will extinguish*. When UNLOCK signal is input, all doors are unlocked and the dome light illuminates for 15 seconds. The dome light fades in, keeps on, and fades out in 15 seconds after the door unlock relay is operated.

*NOTE: *: If doors are locked with the keyless operation key when the dome light is ON while doors are opened, the dome light is switched off in 1.2 seconds. In addition, if doors are locked with the keyless operation key when the dome light is OFF, the dome light does not work.*

KEYLESS ENTRY HORN ANSWERBACK FUNCTION

When the LOCK signal from the keyless operation key is received into ETACS-ECU via receiver antenna assembly, all doors are locked and the horn sounds. If the driver's door cannot be locked even when the keyless operation key is operated, the horn does not sound.

KEYLESS ENTRY TIMER LOCK TIME

When none of the doors are opened within 30 seconds after the doors are unlocked by the keyless entry system, ETACS-ECU automatically outputs the door lock signal to lock the doors. This function prevents the doors from being unlocked unexpectedly by operation errors. Using a customization function, the timer lock period can be changed (Refer to P.42B-28).

OPERATION INHIBITION CONDITIONS

- The operation of the system is inhibited when:
- The emergency key is in the ignition switch.
 - Any door is open (door switch is ON). (including door ajar)

THEFT-ALARM SYSTEM

Refer to GROUP 54A, Theft-alarm system P.54A-44.

PANIC ALARM SYSTEM

Refer to GROUP 54A, Panic alarm system P.54A-46.

ENGINE STARTING FUNCTION (IMMOBILIZER FUNCTION)

M2421009200225

When carrying the keyless operation key, a driver can start/stop the engine by operating only the IG knob. The immobilizer function prevents the engine from starting, and immobilizes the vehicle by prohibiting the engine fuel injection ignition if a method other than the keyless operation key registered for that vehicle is used in an attempt to start the engine after forced entry.

CONSTRUCTION DIAGRAM

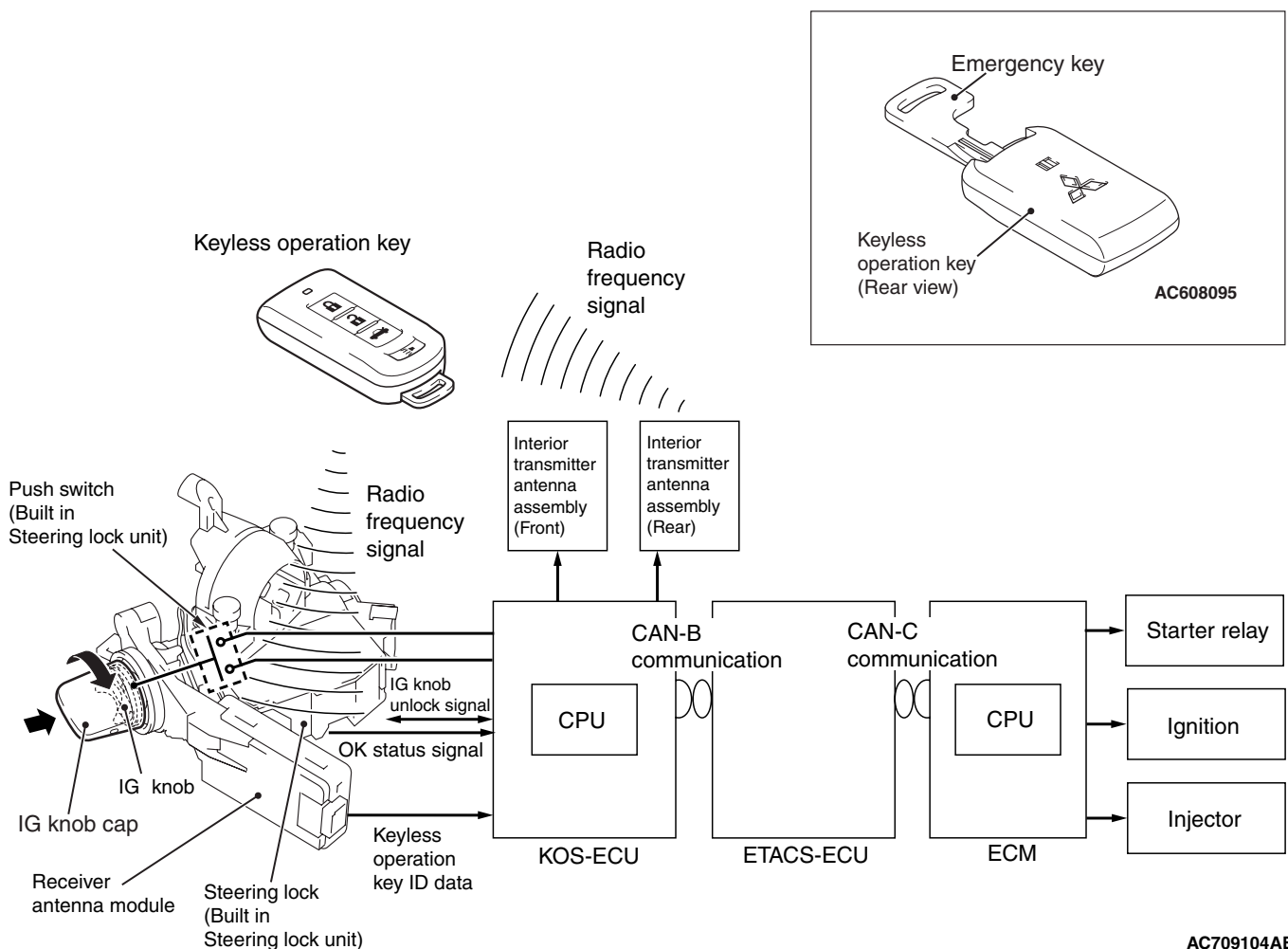

AC709104AB

OPERATION**WHEN THE USER IS CARRYING THE KEYLESS OPERATION KEY**

1. Press the IG knob on the steering lock, and the push switch inside the steering lock is turned ON.
2. When the push switch inside the steering lock is turned ON, KOS-ECU activates the interior transmitter antenna assembly to send the transmitter signal to the keyless operation key.
3. On receiving the transmitter signal from KOS-ECU, the keyless operation key performs the keyless operation key certification and the key ID calculation, and sends the keyless operation key ID data to KOS-ECU. (The keyless operation key cannot receive the transmitter signal from KOS-ECU when it is not located within the engine starting function valid area .)
4. The receiver antenna receives the signal from the keyless operation key, and then KOS-ECU compares the keyless operation key ID data sent from the key with the one registered in it.
5. When this data coincides, KOS-ECU sends the IG knob unlock signal to the steering lock unit inside the steering lock.
6. On receiving the IG knob unlock signal, the steering lock unit performs processing (verification of the KOS ID, etc.) based on the received data. When no problem is found during the processing, the unit sends the OK status signal to KOS-ECU, and at the same time, electrically disengages the steering lock mechanism to make the IG knob rotatable.

KEYLESS OPERATION KEY TAKE OUT MONITORING FUNCTION

KOS-ECU monitors whether the keyless operation key is brought out of the car by performing a certification communication with the keyless operation key inside the car when all the doors are closed. If the keyless operation key is brought out of the car while the IG knob is in the position other than the LOCK (OFF) position, KOS-ECU notifies that the key is brought out of the car.

When none of the registered keyless operation keys (up to four) respond during the communication, KOS-ECU determines that the key has been brought out of the car, and the keyless operation key certification agreement memory "does not exist," and does not permit starting of the engine.

7. When a keyless operation key certification agreement memory "exists" ^{*1} in KOS-ECU when it received the OK status signal from the steering lock unit, the engine start permission communication (CAN communication) is performed between KOS-ECU and the ECM by turning the IG knob from the "ACC" position to the "ON"/"START" position, and the engine starts. If the keyless operation key certification agreement memory "does not exist" ^{*2}, the engine does not start.

NOTE:

- ^{*1}: *The keyless operation key certification agreement memory "exists" means that a registered keyless operation key has been recognized during the keyless operation key certification communication.*
- ^{*2}: *When the keyless operation key certification agreement memory "does not exist," the "keyless operation key bringing-out monitoring function" and the "keyless operation key replacement monitoring function" (keyless operation key monitoring controls) have judged that the keyless operation key has been carried out of the vehicle with the IG knob in the LOCK "(OFF)" position while turning ON the push switch or in the ACC, ON, or START position.*

NOTE: *The monitoring function is inhibited when:*

- *The keyless operation key certification agreement memory "does not exist" from the start.*
- *The emergency key is in the IG knob.*
- *The IG knob is in LOCK "(OFF)" position and the push switch is OFF.*
- *The vehicle is judged running (shift lever is in the position other than "P" or "N" <TC-SST>, or vehicle speed is 6 km/h or higher).*

KEYLESS OPERATION KEY REPLACEMENT MONITORING FUNCTION

If the keyless operation key carrying-out monitoring function once detects that the key has been carried out of the vehicle with the IG knob in the LOCK "(OFF)" position and with the push switch in other than OFF, and then the key is brought into the vehicle, the engine must be started when the IG knob is turned to the ON or START position. For this purpose, KOS-ECU performs the certification communication with the keyless operation key inside the vehicle every 5 seconds to monitor the replacement of the keyless operation key. When any of the registered keyless operation keys sends a response, KOS-ECU determines that the key has been brought into the vehicle (replaced), and sets the keyless operation key certification agreement memory to "exist," and permits starting of the engine.

NOTE: The monitoring function is inhibited when:

- The keyless operation key certification agreement memory "exists" from the start.
- The emergency key is in the IG knob.
- The IG knob is in LOCK (OFF) position and the push switch is OFF.
- The vehicle is judged running (shift lever is in the position other than "P" or "N" <TC-SST>, or vehicle speed is 6 km/h or higher).

ENGINE STARTING FUNCTION VALID AREA

The engine can be started only when the keyless operation key is within the interior antenna receiving area.

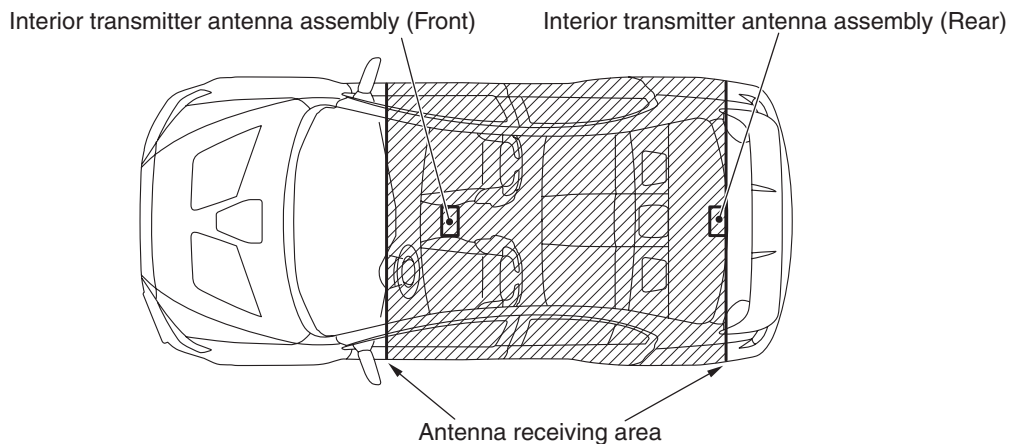

AC709160 AB

Emergency function

The emergency function is adopted, which starts the engine by a combination of emergency key and keyless operation key when the IG knob operation is unavailable in case such as discharged battery. Also, the engine can be started using the conventional ignition key (transponder).

CONSTRUCTION DIAGRAM

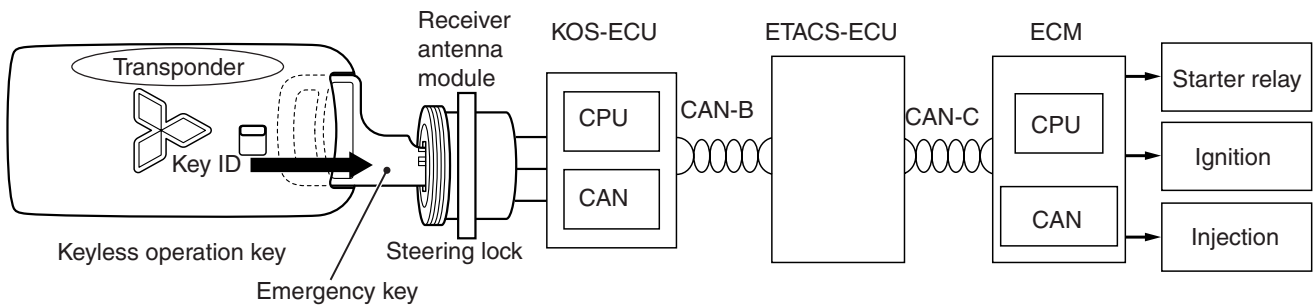

AC707540AC

OPERATION

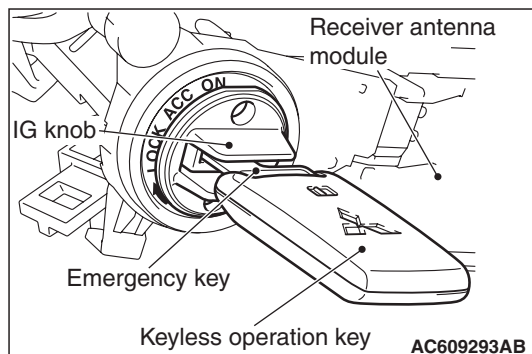

1. Remove the IG knob cap, and insert the emergency key into the keyless operation key in the inverted direction, then insert it into the KOS steering lock. Because the transponder (small transmitter) integrated in the keyless operation key only emits weak radio frequency signals, operate the emergency key with the keyless operation key inserted in the inverted direction. Using the keyless operation key, push in the emergency key, and then turn the key.

2. When the emergency key is turned to the ON position, the transponder integrated in the keyless operation key transmits an ID code unique to each key (key ID) to the receiver antenna module by radio.
3. KOS-ECU compares the sent key ID with the already-registered ID code, and only when they match, KOS-ECU permits the starting of engine. (More than one trillion of ID code combinations can be registered. This feature prevents code copying, resulting in higher security of the system.)

NOTE:

- The transponder integrated in the keyless operation key uses the power supplied from the receiver antenna module. Therefore, it can be used even when the battery in keyless operation key is discharged.
- One keyless operation key is provided, and up to four keys can be registered to one vehicle as needed. Also for the number of emergency keys, the same number of keys as that of keyless operation keys can be registered to one vehicle.
- When KOS-ECU is replaced or when the keyless operation key is lost or added, the ID codes for all the keyless operation keys must be registered again using the scan tool.

TIRE PRESSURE MONITORING SYSTEM (TPMS) FUNCTION

M2421000600022

When the tire pressure becomes under the specified value, the TPMS function warns the driver of that state by illuminating the TPMS warning light.

OPERATION

- The signals from the TPMS transmitter are received by the receiver antenna assembly and sent to KOS-ECU.
- KOS-ECU processes input signals from each TPMS transmitter as well as vehicle speed signals from the ABS-ECU. It receives the atmospheric pressure signal from ECM, and when the atmospheric pressure is low (such as at high altitude), it calibrates the tire pressure received from TPMS transmitter and makes a judgment of warning. When the road tire pressure is low, it sends a warning signal causing the TPMS warning light to be illuminated. When the TPMS has problems, it sends a warning signal causing the TPMS warning light to be flashed*.

*NOTE: *: Change to continuous illumination after flashing for about 1 minute.*

- For 3 seconds after the ignition switch is turned to the "ON" position, KOS-ECU illuminates the TPMS warning light to check any breaks in the TPMS warning light circuit.
- By connecting the scan tool to the data link connector, data stored in KOS-ECU (data of tire pressure and TPMS transmitter ID, the alarm status and warning history, etc.) can be displayed and TPMS transmitter ID can be registered.

NOTE: If the TPMS transmitter is replaced, register the ID codes of all the TPMS transmitters again using the scan tool.

TPMS WARNING LIGHT

The TPMS warning light on the combination meter illuminates or flashes* to alert the driver by request from KOS-ECU. When the tire pressure warning or the fault warning is activated, a warning symbol and a message are displayed on the multi information display.

WARNING DISPLAY PATTERN OF TPMS WARNING LIGHT AND MULTI INFORMATION DISPLAY

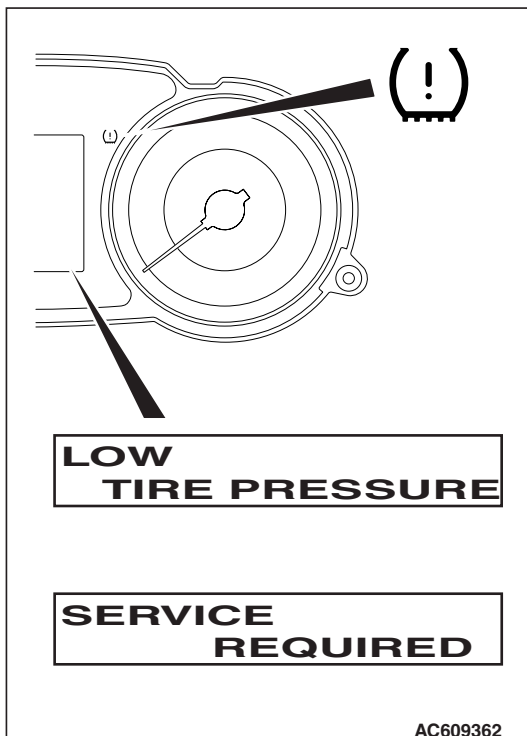

Circumstance	Warning light	Multi information display
For 3 seconds after the ignition switch is turned to the "ON" position (warning light circuit self-check)	Illuminates	No indication
TPMS problems	Flashes*	Symbol and "SERVICE REQUIRED" is displayed
Low tire pressure	Illuminates	Symbol and "LOW TIRE PRESSURE" is displayed

*NOTE: *:Change to continuous illumination after flashing about 1 minute.*

TIRE PRESSURE THRESHOLD VALUES

Item	Tire pressure kPa (psi)
Standard pressure at cold (reference)	220 (32)
Alarm ON pressure	174 (25.2) or less
Alarm OFF pressure	189 (27.4) or more

TPMS TRANSMITTER (TIRE PRESSURE SENSOR)

The TPMS transmitter combines the valve and tire pressure sensor in a single unit. The TPMS transmitters are mounted inside the tires. The TPMS transmitter measures tire pressure directly with its tire pressure sensor and sends radio frequency signals to KOS-ECU via receiver antenna assembly. The TPMS transmitter includes acceleration sensor that senses tire rotation, and change tire pressure sampling and data transmission timing when vehicle is running.

NOTE: Use only genuine wheels. The use of non-genuine wheels may cause the improper installation of the TPMS transmitters, possibly resulting in air leakage and damage to the TPMS transmitter.

TIRE PRESSURE SAMPLING TIMING

Vehicle status	Sampling timing
At vehicle moving	once every 5 seconds
At vehicle stationary	once every 1 minute

NOTE: Vehicle moving = vehicle speed: approximately 25 km/h (15 mph) or more

DATA TRANSMISSION TIMING



Vehicle status	Transmission timing
At vehicle moving	once every 1 minute*
At vehicle stationary	once every 13 hours



If a sampled pressure varies by ± 10 kPa (1.5psi) from the last transmitted pressure value, an additional transmission will occur.

*NOTE: *: Once every 15 seconds for first 30 transmission after vehicle starts moving.*

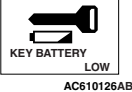

WARNINGS/ALARMS

If the KOS failed, operated improperly, KOS-ECU warns the driver of this by setting off the outer tone alarm and the keyless operation warning indicator, on the multi information display in the combination meter. If the TPMS fails or the tire pressure is low, KOS-ECU warns the driver of that state by the TPMS warning light and the multi information display in the combination meter.

Display contents	Item	State	Warning operations		Warning cancellation conditions (Cancels warning operations when one of the conditions met)
			TPMS warning light	Multi information display	
 <p>KEY BATTERY LOW AC610126AB</p>	Low keyless operation key battery voltage warning	The keyless operation key with low battery voltage is detected when the IG knob is pressed.	—	<ul style="list-style-type: none"> Warning indicator flashes for 30 seconds. The outer tone alarm will not sound. 	<ul style="list-style-type: none"> IG knob in "LOCK" (OFF) position and push switch OFF are detected. 30 seconds have passed after the warning output started.
 <p>KEY MISSING AC610127AB</p>	No keyless operation key detected inside the car	No keyless operation key is detected inside the car when the IG knob is pressed.	—	<ul style="list-style-type: none"> The warning indicator flashes for 5 minutes. The outer tone alarm will not sound. 	<ul style="list-style-type: none"> IG knob in "LOCK" (OFF) position and push switch OFF are detected. 5 minutes have passed after the warning output started.
 <p>STEERING WHEEL LOCK AC610124AB</p>	IG knob is not returned properly.	Opening of the driver's door is detected when the IG knob is in ACC or LOCK position and the push switch is ON.	—	<ul style="list-style-type: none"> The warning indicator flashes for 5 minutes. The outer tone alarm will not sound. Key reminder warning tone alarm sounds until closing of the driver's door is detected. 	<ul style="list-style-type: none"> The IG knob in the "RUN" or "START" position, or the IG knob in the "LOCK" (OFF) position, and the push switch OFF are detected. The driver's door is detected closed from the open position. 5 minutes have passed after the warning output started.

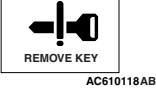
Display contents	Item	State	Warning operations		Warning cancellation conditions (Cancels warning operations when one of the conditions met)
			TPMS warning light	Multi information display	
 <p>CONFIRM KEY LOCATION AC610128AC</p>	Keyless operation key brought out of the car warning	The keyless operation key is carried out of the vehicle when the IG knob is in the position other than the LOCK position, and all the doors are closed.	—	<ul style="list-style-type: none"> The warning indicator flashes for 5 minutes. Outer tone alarm sounds for 5.69 seconds in pattern 2. 	<ul style="list-style-type: none"> IG knob in "LOCK" (OFF) position and push switch OFF are detected. KOS-ECU has detected a keyless operation key inside the vehicle. 5 minutes have passed after the warning output started.
 <p>CHECK DOORS AC610129AB</p>	Door lock does not operate.	Push switch is pressed ON when the IG knob is in other than LOCK position.	—	<ul style="list-style-type: none"> Warning indicator flashes for 5 seconds. Outer tone alarm sounds for 2.96 seconds in pattern 1. 	<ul style="list-style-type: none"> IG knob in "LOCK" (OFF) position and push switch OFF are detected. 5 seconds have passed after the warning output started.
Push switch is pressed ON when the keyless operation key is inside the car.		<ul style="list-style-type: none"> Lock switch on the keyless operation switch is pressed again. 5 seconds have passed after the warning output started. 			
Push switch is pressed ON when the door is ajar.		<ul style="list-style-type: none"> All doors are closed. 5 seconds have passed after the warning output started. 			

Display contents	Item	State	Warning operations		Warning cancellation conditions (Cancels warning operations when one of the conditions met)
			TPMS warning light	Multi information display	
	System error	Push switch is pressed ON from OFF when an error has been detected in EEPROM in KOS-ECU.	-	<ul style="list-style-type: none"> The warning indicator flashes for 5 minutes. The outer tone alarm will not sound. 	5 minutes have passed after the push switch was pressed ON and IG knob is in "LOCK" (OFF) position.
		Push switch is pressed ON from OFF while open circuit in the transmitter antennas are being detected.			
		The push switch is pressed ON from OFF while short circuit in the power supply output (steering lock, transmitter antennas, receiver antenna module, etc.) is detected.			
		Steering lock communication error has been detected when the push switch was pressed ON.			
		The IG knob is in other than the LOCK position while some error is being detected.			
Not displayed	TPMS warning light bulb open circuit check	The ignition switch is turned from "LOCK" (OFF) to "ON."	Illuminates for 3 seconds.	-	3 seconds have passed after the TPMS warning light is lit.

Display contents	Item	State	Warning operations		Warning cancellation conditions (Cancels warning operations when one of the conditions met)
			TPMS warning light	Multi information display	
a 	Tire pressure alarm	The received tire pressure value is under the alarm ON threshold value.	Illuminates.	Symbol and "LOW TIRE PRESSURE" is displayed.	The received tire pressure value is over the alarm OFF threshold value.
b 	TPMS failure warning	ID not stored	Flashes *	Symbol and "SERVICE REQUIRED" is displayed.	ID is registered normally.
Defective EEPROM		Abnormality of data in the EEPROM of the KOS-ECU is detected.			Data in the EEPROM of the KOS-ECU is checked to be normal.
Problem in signal reception		The signals from TPMS transmitters cannot be received while driving for about 20 minutes.			The signal from the TPMS transmitter that was warned is received.
Defective sensor		The sensor failure signal is received from the TPMS transmitter.			A normal signal is received from the TPMS transmitter that was warned.
The battery voltage of the TPMS transmitter is low.		The reception problem warning is activated because of the low battery voltage of the TPMS transmitter.			The signal of normal battery voltage is received from the TPMS transmitter that was warned.
Vehicle speed input problem		The vehicle speed is not input.			The vehicle speed is input.
Abnormal vehicle speed value		The vehicle speed value is abnormal.			The normal vehicle speed value is received.

NOTE:

*: Change to continuous illumination after flashing for about 1 minute.

<Sound pattern 1>

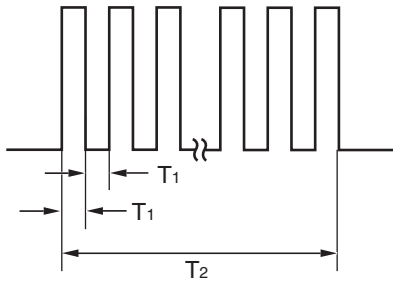

$T_1 : 0.08 \pm 0.01$ seconds
 $T_2 : 2.96$ seconds

<Sound pattern 2>

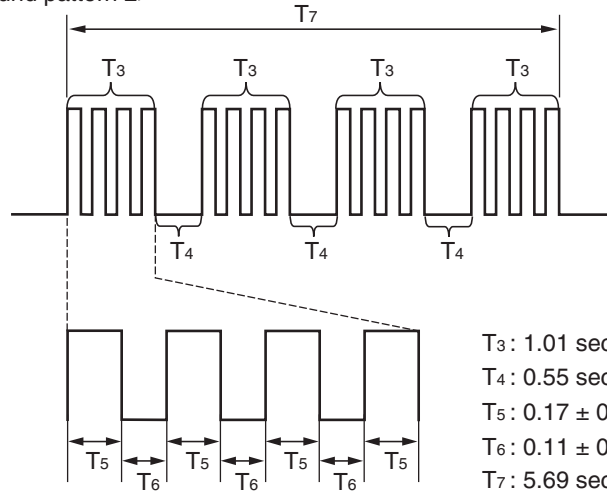

$T_3 : 1.01$ seconds
 $T_4 : 0.55$ seconds
 $T_5 : 0.17 \pm 0.01$ seconds
 $T_6 : 0.11 \pm 0.01$ seconds
 $T_7 : 5.69$ seconds

AC501053AC

CUSTOMIZATION FUNCTION

M2421000300203

By operating the ETACS system or MMCS of scan tool MB991958, the following functions can be programmed. The programmed information is held even when the battery is disconnected.

Adjustment item (scan tool MB991958 display)	Adjustment item	Adjusting contents (scan tool MB991958 display)	Adjusting content
Hazard answer back	Adjustment of the number of keyless hazard warning light answer back flashes	Lock:1, Unlock:2	LOCK: Flashes once, UNLOCK: Flashes twice (default)
		Lock:1, Unlock:0	LOCK: Flashes once, UNLOCK: No flash
		Lock:0, Unlock:2	LOCK: No flash, UNLOCK: Flash twice
		Lock:2, Unlock:1	LOCK: Flash twice, UNLOCK: Flash once
		Lock:2, Unlock:0	LOCK: Flash twice, UNLOCK: No flash
		Lock:0, Unlock:1	LOCK: No flash, UNLOCK: Flash once
		Lock:0, Unlock:0	No function
Dome light delay timer with door	Adjustment of interior light delay shutdown time	0 sec	0 second (no delay shutdown time)
		7.5 sec	7.5 seconds
		15 sec	15 seconds
		30 sec	30 seconds (default)
		60 sec	60 seconds
		120 sec	120 seconds
		180 sec	180 seconds
Door unlock mode	Door lock system	All doors unlock	All the doors are unlocked when the driver's side door is unlocked.
		Dr door unlock	Only the driver's side door is unlocked when the driver's side door is unlocked. (default)
Auto door unlock by P position	Auto door unlock by P position function <Vehicles with TC-SST>	Disable	No function (default)
		Always enabled	Always with function
Duration of horn chirp	Horn sounding time during horn answer back	Short	0.01 second (default)
		Long	0.02 second

Adjustment item (scan tool MB991958 display)	Adjustment item	Adjusting contents (scan tool MB991958 display)	Adjusting content
Horn chirp by keyless	Horn chirp by keyless entry system <vehicles without auto light>	Not sound horn	No horn answerback function
		Lock any time	The horn sounds when the lock button of keyless entry transmitter is pressed once.
		W lock any time	The horn sounds when the lock button of keyless entry transmitter is pressed twice. (default)
		Not sound horn	No horn answerback function
	Horn chirp by keyless entry system <vehicles with auto light>	Lock any time	The horn sounds when the lock button of keyless entry transmitter is pressed once.
		Lock/auto ON	During daytime, while the lighting switch is in the AUTO position, the horn sounds once when the lock is pressed once.
		W lock any time	The horn sounds when the lock button of keyless entry transmitter is pressed twice. (default)
		Not sound tone alarm	No function
Tone alarm answer back	Adjusts the tone alarm answer back function	At keyless	Sounds when the keyless entry system is activated.
		At F.A.S.T.	Sounds when KOS is activated (default).
		At Both	Sounds when the keyless entry system or KOS is activated.
		30 sec	30 seconds (default)
Timer lock timer	Timer lock period adjustment	60 sec	60 seconds
		120 sec	120 seconds
		180 sec	180 seconds
		Disable	No function
Panic alarm switch	With/without panic alarm function	Enable	With function (default)
		Enable	No function
F.A.S.T. key out of car	With/without KOS key exterior detection function	Disable	With function (default)
		Both enable	All KOS functions are enabled (default).
F.A.S.T. feature	KOS function adjustment	DoorEntry enable	Only door entry function is enabled.
		ENG strt enable	Only engine starting function is enabled.
		Both disabled	All KOS functions are disabled.
		0 sec	0 seconds
F.A.S.T. unlock disable time	Adjusts the door unlock inhibition period after door lock is activated	3 sec	3 seconds (default)
		5 sec	5 seconds

NOTES