

## GROUP 54C

# CONTROLLER AREA NETWORK (CAN)

## CONTENTS

GENERAL INFORMATION .....	54C-2	EXPLANATION ABOUT THE SCAN TOOL (M.U.T.-III) CAN BUS DIAGNOSTICS .....	54C-9
SPECIAL TOOLS.....	54C-5	DIAGNOSIS .....	54C-15
TEST EQUIPMENT .....	54C-6	CAN BUS DIAGNOSTICS TABLE .....	54C-15
SERVICE PRECAUTIONS.....	54C-7	CAN-RELATED CONNECTOR POSITION..	54C-26
PRECAUTIONS ON HOW TO REPAIR THE CAN BUS LINES .....	54C-8	CAN BUS DIAGNOSTICS.....	54C-28
		CAN COMMUNICATION-RELATED DTC (U-CODE) TABLE.....	54C-269

## GENERAL INFORMATION

M1548310000579

CAN, an abbreviation for Controller Area Network, is an ISO-certified international standard for a serial multiplex communication protocol\*. A communication circuit employing the CAN protocol connects each ECU, and sensor data can be shared among, which enables more reduction in wiring.

*NOTE: \*: The regulations have been decided in detail, from software matters such as the necessary transmission rate for communication, the system, data format, and communication timing control method to hardware matters such as the harness type and length and the resistance values.*

CAN offers the following advantages.

- Transmission rates are much faster than those in conventional communication (up to 1 Mbps), allowing much more data to be sent.
- It is exceptionally immune to noise, and the data obtained from each error detection device is more reliable.
- Each ECU connected via the CAN communicates independently, therefore if the ECU enters damaged mode, communications can be continued in some cases.

STRUCTURE

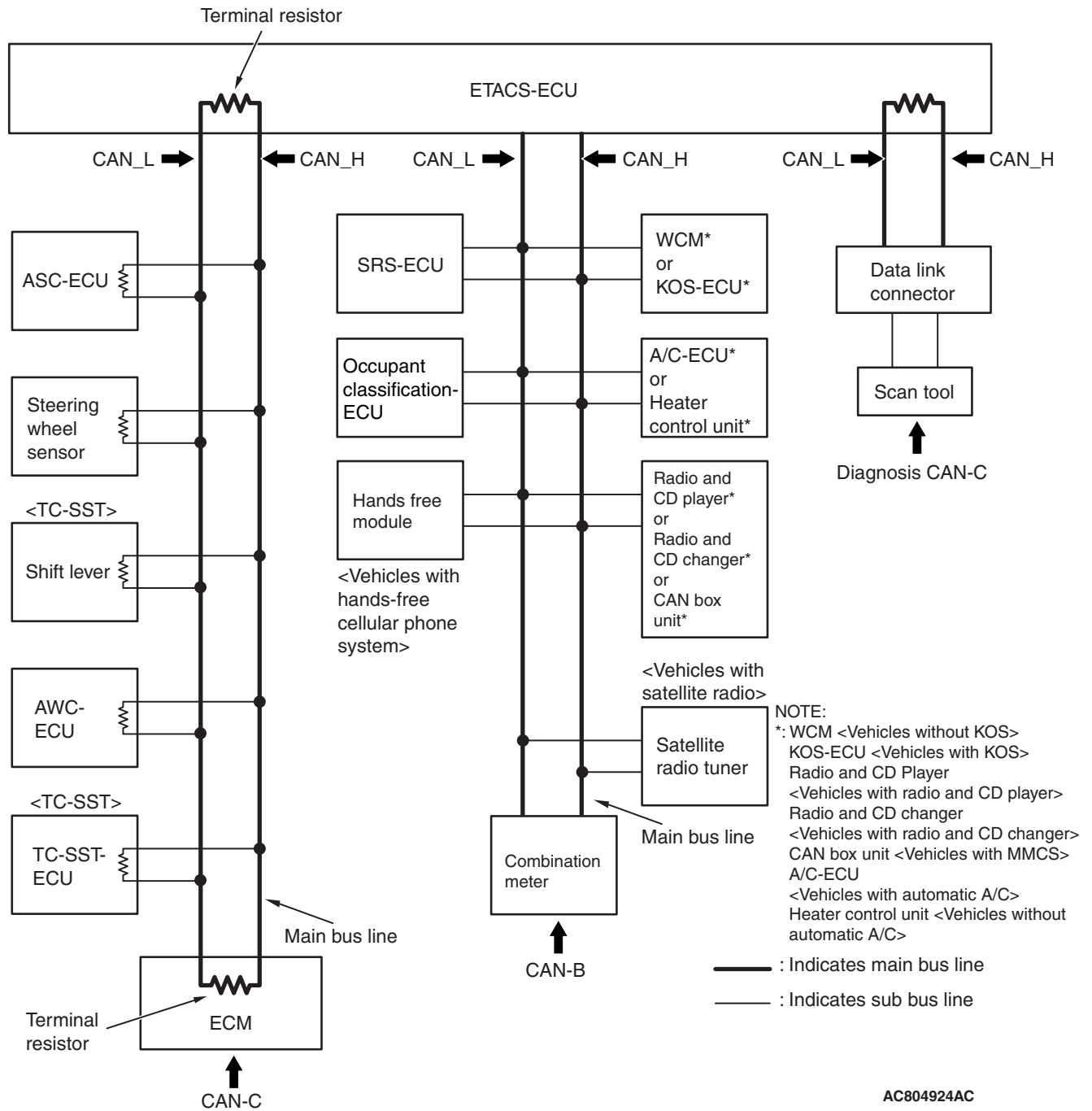

- A gateway function has been integrated to ETACS-ECU as the network central ECU.
- The CAN system consists of the following three networks: CAN-B (middle-speed body network), CAN-C (high-speed power train network), and the diagnosis CAN-C (diagnosis exclusive network). Each ECU is connected to one of the networks depending on its functions.
- The CAN bus line consists of two lines, CAN\_L and CAN\_H (CAN Low and CAN High, respectively), as well as two terminal resistors (A twisted-pair cable, highly resistant to noise, is used for the communications line).
- The CAN bus line connecting two dominant ECUs is the main bus line, and the CAN bus line connecting each ECU is the sub-bus line.

- With CAN-C, the terminal resistors are incorporated in ECU. Resistors with approximately 120 ohms is used for the dominant ECU, and that with 3.0 kilohms is used for the non-dominant ECU.

**NOTE:**

- *Dominant ECU: ETACS-ECU and engine ECU*
- *Non-dominant ECU: ECU and sensor on CAN-C network, excluding ETACS-ECU and engine ECU*
- To the CAN bus line, ECU, sensor, and data link connector are connected as follows for each network.

**CAN-B**

- Wireless control module (WCM) <vehicles without KOS>
- KOS-ECU <vehicles with KOS>
- SRS-ECU
- Occupant classification-ECU
- A/C-ECU <vehicles with automatic A/C>

- Heater control unit <vehicles without automatic A/C>
- Radio and CD player <vehicles with radio and CD player>
- Radio and CD changer <vehicles with radio and CD changer>
- CAN box unit <vehicles with MMCS>
- Hands free module <vehicles with hands-free cellular phone system>
- Satellite radio tuner <vehicles with satellite radio>
- Combination meter

**CAN-C**

- ASC-ECU
- TC-SST-ECU <TC-SST>
- Shift lever <TC-SST>
- AWC-ECU
- Steering wheel sensor
- Engine control module (ECM)

**Diagnosis CAN-C**





- Data link connector

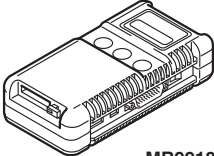
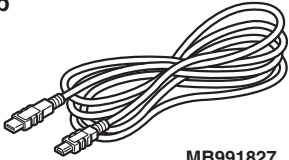
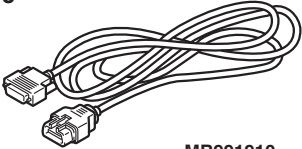
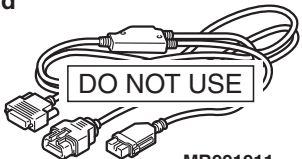
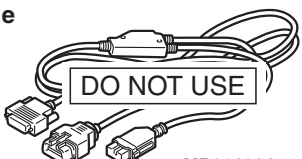
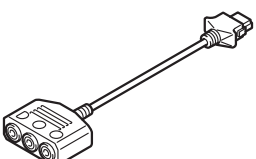
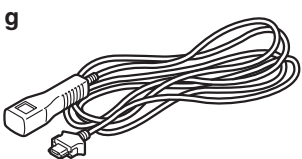

**SPECIAL TOOLS**

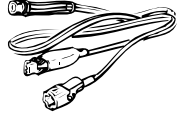
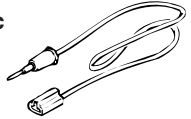
M1548304200477

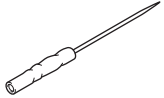
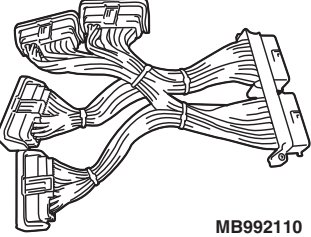
Tool	Tool number and name	Supersession	Application
<p>a</p>  <p>MB991824</p> <p>b</p>  <p>MB991827</p> <p>c</p>  <p>MB991910</p> <p>d</p>  <p>MB991911</p> <p>e</p>  <p>MB991914</p> <p>f</p>  <p>MB991825</p> <p>g</p>  <p>MB991826 MB991958</p>	<p>MB991958</p> <p>a. MB991824</p> <p>b. MB991827</p> <p>c. MB991910</p> <p>d. MB991911</p> <p>e. MB991914</p> <p>f. MB991825</p> <p>g. MB991826</p> <p>M.U.T.-III sub assembly</p> <p>a. Vehicle communication interface (V.C.I.)</p> <p>b. M.U.T.-III USB cable</p> <p>c. M.U.T.-III main harness A (Vehicles with CAN communication system)</p> <p>d. M.U.T.-III main harness B (Vehicles without CAN communication system)</p> <p>e. M.U.T.-III main harness C (for Chrysler models only)</p> <p>f. M.U.T.-III measurement adapter</p> <p>g. M.U.T.-III trigger harness</p>	<p>MB991824-KIT</p> <p><i>NOTE: G: MB991826 M.U.T.-III Trigger Harness is not necessary when pushing V.C.I. ENTER key.</i></p>	<p><b>⚠ CAUTION</b></p> <p><b>M.U.T.-III main harness A (MB991910) should be used. M.U.T.-III main harness B and C should not be used for this vehicle.</b></p> <p>CAN bus diagnostics</p>

Tool	Tool number and name	Supersession	Application
<p>a</p>  <p>b</p>  <p>c</p>  <p>d</p> 	<p>MB991223</p> <p>a. MB991219</p> <p>b. MB991220</p> <p>c. MB991221</p> <p>d. MB991222</p> <p>Harness set</p> <p>a. Test harness</p> <p>b. LED harness</p> <p>c. LED harness adaptor</p> <p>d. Probe</p>	General service tools	<p>Continuity check and voltage measurement at harness wire or connector for loose, corroded or damaged terminals, or terminals pushed back in the connector.</p> <p>a. Connector pin contact pressure inspection</p> <p>b. Power circuit inspection</p> <p>c. Power circuit inspection</p> <p>d. Commercial tester connection</p>
 <p>MB992006</p>	<p>MB992006</p> <p>Extra fine probe</p>	–	Continuity check and voltage measurement at harness wire or connector for loose, corroded or damaged terminals, or terminals pushed back in the connector.
 <p>MB992110</p>	<p>MB992110</p> <p>Power plant ECU check harness</p>	–	Measure the voltage and resistance at the engine control module (ECM)
 <p>MB991997</p>	<p>MB991997</p> <p>ASC check harness</p>	–	Measure the voltage and resistance at the ASC-ECU

**TEST EQUIPMENT**

M1548304300258

Test equipment	Name	Use
 <p>AC000019</p>	Digital multimeter	Checking CAN bus circuit (for resistance and voltage measurements)

## SERVICE PRECAUTIONS

M1548302100258

Warnings in diagnosis section	Details regarding warnings
<p><b>⚠ CAUTION</b> When servicing a CAN bus line, ground yourself by touching a metal object such as an unpainted water pipe. If you fail to do, a component connected to the CAN bus line may be broken.</p>	<p>–</p>
<p><b>⚠ CAUTION</b> A digital multimeter should be used.</p>	<p>When measuring resistance value or voltage in CAN bus lines, use a digital multimeter. If not using a digital multimeter, the equipments, which are connected through the CAN communication lines, may be damaged.</p>
<p><b>⚠ CAUTION</b> When measuring the resistance, disconnect the negative battery terminal.</p>	<p>Disconnect the negative battery terminal when measuring the resistance value in the CAN bus line. If you fail to do so, the equipments, which are connected through the CAN communication lines, may be damaged.</p>
<p><b>⚠ CAUTION</b> The test wiring harness should be used.</p>	<p>Always use the test harness when measuring the voltage or resistance value at the female connector. If you fail to do so, connectors may be damaged.</p>
<p><b>⚠ CAUTION</b> The strand end of the twist wire should be within 10 cm from the connector.</p>	<div data-bbox="816 999 1339 1339" data-label="Diagram"> <p>The diagram shows a cross-section of a twisted wire on the left, which transitions into a straight wire leading to a rectangular connector on the right. A horizontal dimension line with arrows at both ends spans the distance between the end of the twisted section and the connector. Above this line, the text reads 'Within 10 cm (4.0 inches) Connector'. An arrow points to the end of the straight wire section. The label 'AC203824AI' is located at the bottom right of the diagram.</p> </div> <p>If you repair the wire due to a defective connector or its terminal or harness wire, you should cut the wire so that the strand end of the twist wire should be within 10 cm (4 inches) from the connector as shown. If it exceeds 10 cm (4 inches), twist the wiring harness just like the original twisted wire. If the strand end exceeds 10 cm (4 inches), a communication error may be caused.</p>
<p><b>⚠ CAUTION</b> Strictly observe the specified wiring harness repair procedure.</p>	<p>When you repair a CAN bus line, observe the precautions on how to repair the CAN bus line strictly. Refer to <a href="#">P.54C-8</a>. If a new wire is added or a splice point is modified for the CAN_L or CAN_H line, an error in the CAN communication may be caused.</p>

# PRECAUTIONS ON HOW TO REPAIR THE CAN BUS LINES

M1548301900251

## PRECAUTIONS ON HOW TO REPAIR THE CAN BUS LINES

- If the CAN bus line(s) are repaired, renew all the twisted wires between the end connectors. If the wiring harness is partially repaired, or only CAN\_L or CAN\_H line is repaired, noise suppression is deteriorated, causing a communication error.
- If the connector or wire on the main bus line or the sub-bus wire is replaced, the frayed end of the twisted wire should be within 10 cm (4 inches) from the connector. If it exceeds 10 cm (4 inches), twist the wiring harness just like the original twisted wire. If the frayed end exceeds 10 cm (4 inches), noise suppression is deteriorated, causing a communication error.
- If a sub-bus line is repaired, splice a new wire directly into the main bus line. If a new wire is spliced into the sub-bus line, which is connected to another device, the CAN communication will be disabled.

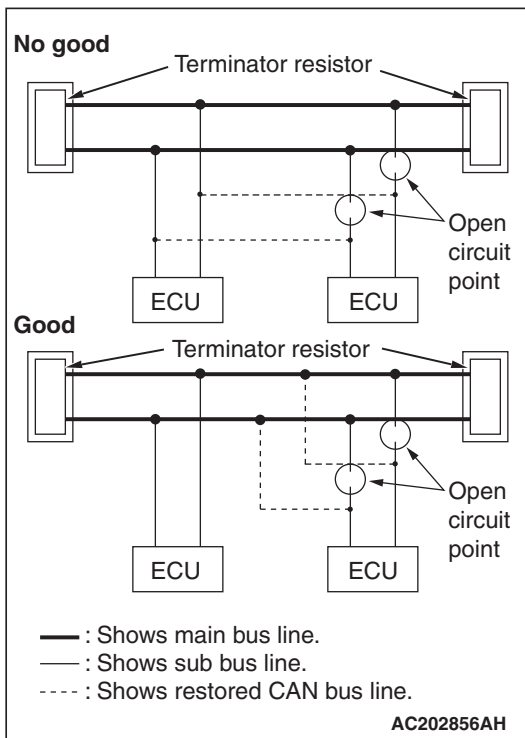
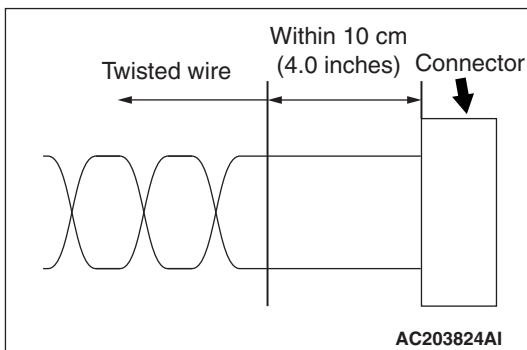
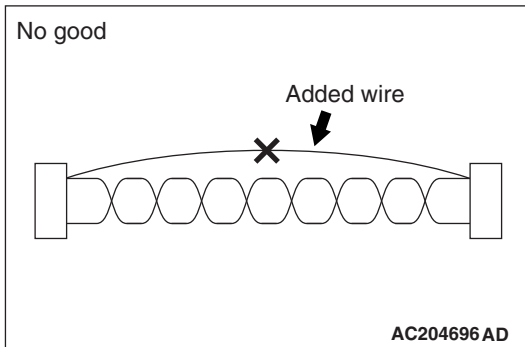

**PRECAUTIONS ON HOW TO REPAIR THE TERMINATOR RESISTOR**

If one-side terminator resistor is broken, the CAN communication will continue although noise suppression is deteriorated. No diagnostic trouble code may be set even if the terminator resistor was broken. If damage is found, replace the ECU which incorporates the defective terminator resistor.

**CAN BUS LINE REPAIR HARNESS (PART NAME AND NUMBER)**

Part name	Part number
Twist pair cable	MN151514

**EXPLANATION ABOUT THE SCAN TOOL (M.U.T.-III) CAN BUS DIAGNOSTICS**

M1548300100490

Scan tool MB991958 CAN bus diagnostics carries out the two checks below automatically, and then displays current condition of the CAN bus lines according to the check results.

**CAN BUS LINE DIAGNOSTIC FLOW**

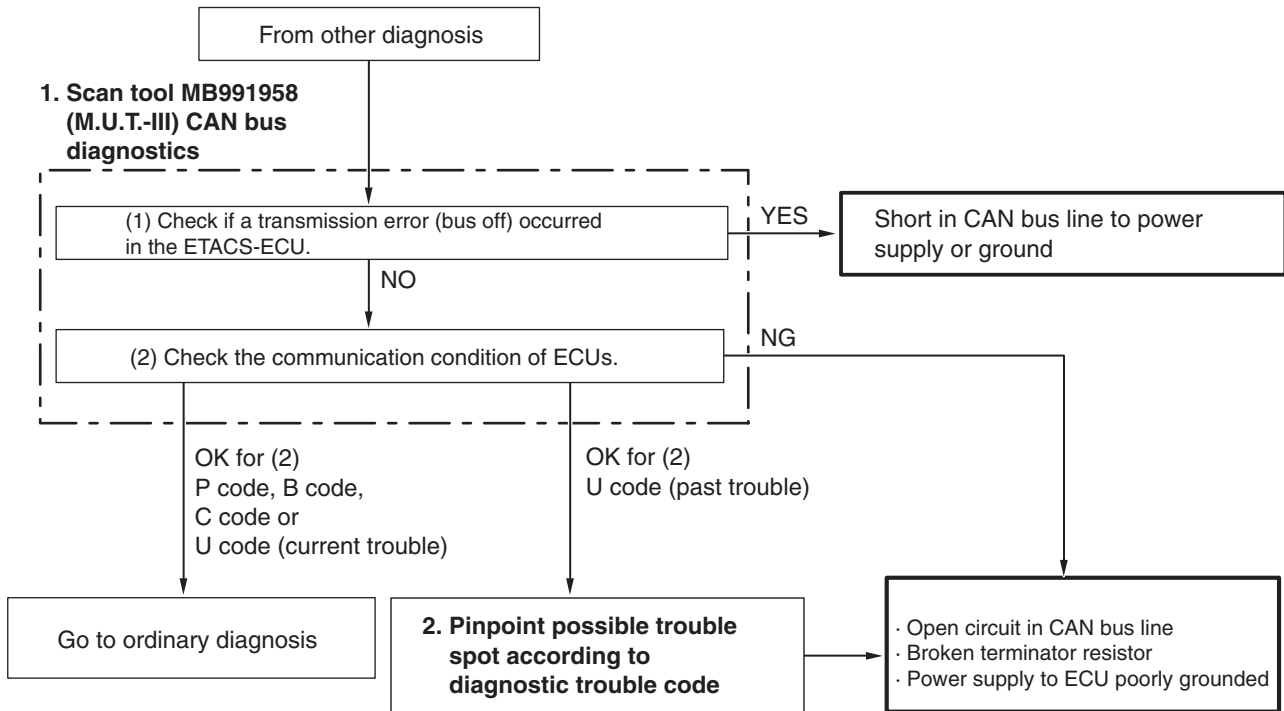

AC507612AE

**1. Scan tool CAN bus diagnostics**

Scan tool MB991958 diagnoses CAN bus lines in accordance with the following strategy.

*NOTE: After you determine whether the CAN-C lines are in good condition, then determine whether the CAN-B lines are in good condition. Then confirm each judgment result on the scan tool screen.*

**(1) Check that the ETACS-ECU sets a diagnostic trouble code.**

You can narrow down the points to be diagnosed by confirming an ETACS-ECU diagnostic trouble code.

**(2) Checking the communication condition of ECUs**

Scan tool MB991958 narrows down troubles in circuit by itself. Its strategies are as follows.

Reference circuit

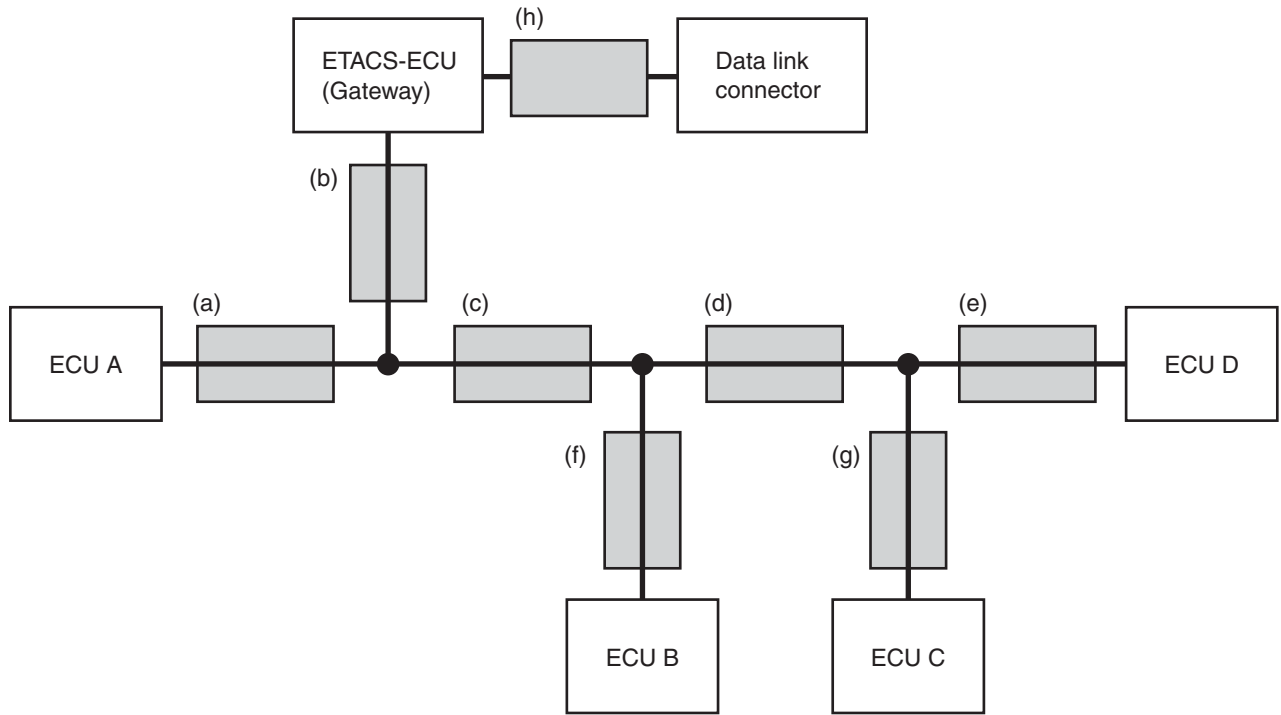

AC204741AD

ECU which cannot communicate with the scan tool	Possible trouble spot	Logic for narrowing down trouble spot
ETACS-ECU and all ECUs	CAN bus line (h) and power supply system to ETACS-ECU	<p>The ETACS-ECU and the other ECUs use the CAN bus line (h) when they communicate with scan tool MB991958. Since none of the ETACS-ECU and the other ECUs can communicate with scan tool MB991958, CAN bus line (h) or the power supply circuit to the ETACS-ECU may be faulty.</p> <p align="right"><b>AC204742BO</b></p>
ECU A	CAN bus line (a) and power supply system to ECU A	<p>ECU A communicates with the scan tool MB991958 via CAN bus lines (a) and (b). Scan tool MB991958 judges that CAN bus line (b) is normal, because it can communicate with other ECUs. Possible trouble may be present in CAN bus line (a) or the power supply system to ECU A.</p> <p align="right"><b>AC204742BH</b></p>
ECU C	CAN bus line (g) and power supply system to ECU C	<p>The ECU C communicates with scan tool MB991958 via CAN bus lines (b), (c), (d) and (g). Scan tool MB991958 judges that CAN bus lines (b), (c) and (d) are normal, because it can communicate with ECUs B and D. Possible trouble may be present in CAN bus line (g) or the power supply system to ECU C.</p> <p align="right"><b>AC204742BI</b></p>

ECU which cannot communicate with the scan tool	Possible trouble spot	Logic for narrowing down trouble spot	
ECU C and ECU D	Trouble in CAN bus line (d)	<p>ECUs C and D communicate with scan tool MB991958 via CAN bus lines (b), (c), (d), (e) and (g). Scan tool MB991958 judges that CAN bus lines (b) and (c) are normal, because it can communicate with ECU B. Possible trouble may be present in CAN bus line (d), (e) or (g) or the power supply system to ECU C and ECU D. CAN bus line (d) is shared by ECUs C and D when they communicate with scan tool MB991958, so CAN bus line (d) is suspected as ultimate cause. CAN bus line (g) or (e) and power supply systems to ECU C or D are also suspected as second cause.</p>	<p>AC204742BJ</p>
ECU B and ECU D	CAN bus line (e) or (f) or power supply system to ECU B or D	<p>ECUs B and D communicate with scan tool MB991958 via CAN bus lines (b), (c), (d), (e) and (f). Scan tool MB991958 judges that CAN bus lines (b), (c) and (d) are normal, because it can communicate with ECU C. Possible trouble may be present in CAN bus line (f) or (e) or the power supply system to ECU B or ECU D.</p>	<p>AC204742BK</p>
All ECU (except ETACS-ECU)	CAN bus line (b)	<p>The other ECUs except the ETACS-ECU use CAN bus lines (b) and (h) when they communicate with scan tool MB991958. It must be assumed that CAN bus line (b) is defective since the ETACS-ECU can communicate with scan tool MB991958.</p>	<p>AC204742BP</p>

2. Pinpoint possible trouble spot according to diagnostic trouble code

If diagnostic trouble code related to CAN communication is set as past trouble, isolate opens as described below.



*NOTE: If you pinpoint trouble spot according to diagnostic trouble code, you should use time-out diagnostic trouble code. Diagnostic trouble code related to failure information is set when the data to be set contains an error, so CAN bus line itself is probably normal.*

*NOTE: Time-out diagnostic trouble codes are stored in each ECU memory individually. Therefore, it is possible that these diagnostic trouble codes have not been set simultaneously. If the trouble spot cannot be found when you diagnose by judging from multiple diagnostic trouble codes, check the communication lines between each ECU.*

Diagnostic trouble code to be set	Possible trouble spot	Logic for narrowing down trouble spot
Time-out diagnostic trouble code associated with ECU D is stored in ECU A, ECU B and ECU C.	Trouble in CAN bus line (e) and power supply system to ECU D	When time-out diagnostic trouble code associated with ECU D is stored in ECU A, B and C, or time-out diagnostic trouble code associated with ECUs A, B and C is stored in ECU D, or "bus off" diagnostic trouble code is stored in ECU D, CAN bus line (e) is suspected. When diagnostic trouble code is not stored in ECU D, the power supply to ECU D is suspected.
Time-out diagnostic trouble code associated with ECUs A, B and C is stored in ECU D.		
"Bus off" diagnostic trouble code is stored in ECU D.		
Time-out diagnostic trouble code associated with ECU A is stored in ECUs B, C and D.	Trouble in CAN bus line (a) or (c) and power supply system to ECU A.	When time-out diagnostic trouble code associated with ECU A is stored in ECUs B, C and D, or time-out diagnostic trouble code associated with ECUs B, C and D is stored in ECU A, or "bus off" diagnostic trouble code is stored in ECU A, CAN bus line (a) or (c) is suspected. When diagnostic trouble code is not stored in ECU A, the power supply to ECU A is suspected.
Time-out diagnostic trouble code associated with ECUs B, C and D is stored in ECU A.		
"Bus off" diagnostic trouble code is stored in ECU A.		

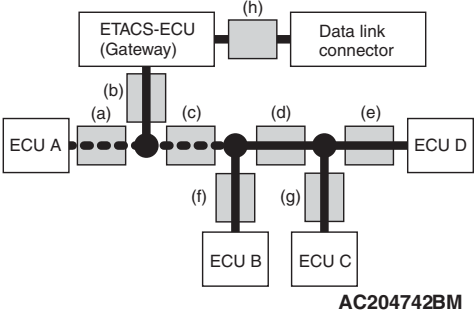
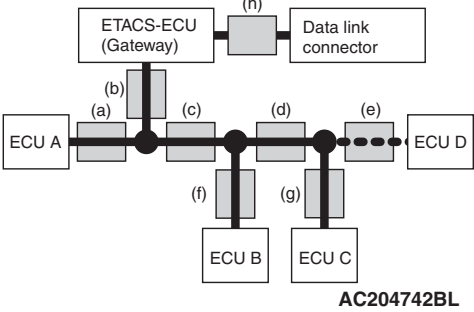

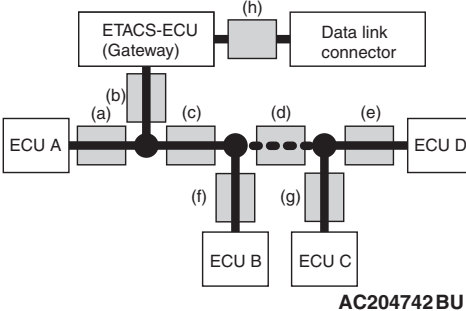
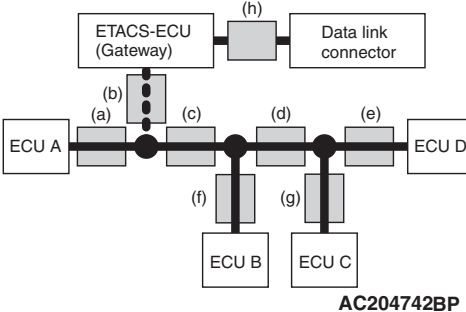
Diagnostic trouble code to be set	Possible trouble spot	Logic for narrowing down trouble spot	
Time-out diagnostic trouble codes associated with ECUs C and D are stored in ECU A and ECU B.	Trouble in CAN bus line (d)	If time-out diagnostic trouble codes associated with ECUs C and D are stored in ECUs A and B, or time-out codes associated with ECUs A and B are stored in ECUs C and D, CAN bus line (d) is suspected. CAN bus line (g) or (e) and power supply systems to ECU C or D are also suspected as second cause.	 <p style="text-align: right;">AC204742BU</p>
Time-out diagnostic trouble codes associated with ECUs A and B are stored in ECU C and ECU D.	Trouble in CAN bus line (d)		
Time-out diagnostic trouble codes associated with ECUs A, B, C and D are stored in ETACS-ECU.	Trouble in CAN bus line (b)	It must be assumed that a fault was present in CAN bus line (b) when the ETACS-ECU has set a time-out diagnostic trouble code for ECU A, B, C or D.	 <p style="text-align: right;">AC204742BP</p>
Time-out diagnostic trouble codes associated with ETACS-ECU is stored in ECU A, B, C and ECU D.	Trouble in CAN bus line (b)		

## DIAGNOSIS

### CAN BUS DIAGNOSTICS TABLE

M1548300200914

**⚠ CAUTION**

A diagnostic trouble code may not also be set in the CAN-B lines under the conditions below. If no diagnostic trouble code has been set due to electrical noise, confirm diagnosis item 27 [P.54C-210](#).

- Open circuit at the CAN\_H side of the CAN-B bus lines
- Open circuit at the CAN\_L side of the CAN-B bus line
- Short to ground at the CAN\_H side of the CAN-B bus line

**⚠ CAUTION**

During diagnosis, a diagnostic trouble code associated with another system may be set when the ignition switch is turned on with connector(s) disconnected. After completing the repair, confirm all systems for diagnostic trouble code(s). If diagnostic trouble code(s) are set, erase them all. This diagnosis applies only to the CAN bus lines. If a different system is defective, proceed to the applicable diagnosis section for each system. Observe the diagnosis procedure below only when the CAN bus line is defective.

Scan tool screen (The ECUs that are not adopted are not displayed.)	Comment	Diagnosis detail	Reference page
<p><b>&lt;M/T&gt;</b>    <b>AC709520AB</b></p> <p><b>&lt;TC-SST&gt;</b>    <b>AC709521AB</b></p>	<p>Short circuit to battery in red displayed area is estimated.</p>	<p>Diagnosis Item 1 Diagnose when the scan tool cannot receive the data sent by ETACS-ECU.</p>	<p><a href="#">P.54C-28</a></p>
<p><b>&lt;M/T&gt;</b>    <b>AC709520AC</b></p> <p><b>&lt;TC-SST&gt;</b>    <b>AC709521AC</b></p>	<p>Grounding in red displayed area is estimated.</p>	<p>Diagnosis Item 2 Malfunction of the ETACS-ECU.</p>	<p><a href="#">P.54C-33</a></p>

<b>Scan tool screen</b> <b>(The ECUs that are not adopted are not displayed.)</b>	<b>Comment</b>	<b>Diagnosis detail</b>	<b>Reference page</b>
<p align="right"><b>AC709520AD</b></p>	<p>CAN-C: A bus-off failure is present in the gateway ECU.</p>	<p>Diagnosis Item 3 Abnormal short between the CAN-C bus lines.</p>	<p><a href="#">P.54C-34</a></p>
<p align="right"><b>AC709521AD</b></p>	<p>CAN-C: Grounding in red displayed area is estimated</p>	<p>Diagnosis Item 4 Diagnose shorts in the ground to CAN-C bus line.</p>	<p><a href="#">P.54C-51</a></p>
<p align="right"><b>AC709520AE</b></p>	<p>CAN-C: Disconnection in red displayed area is estimated.</p>	<p>Diagnosis Item 6 Diagnose when the scan tool cannot receive the data sent by AWC-ECU.</p>	<p><a href="#">P.54C-97</a></p>
<p align="right"><b>AC709521AE</b></p>			

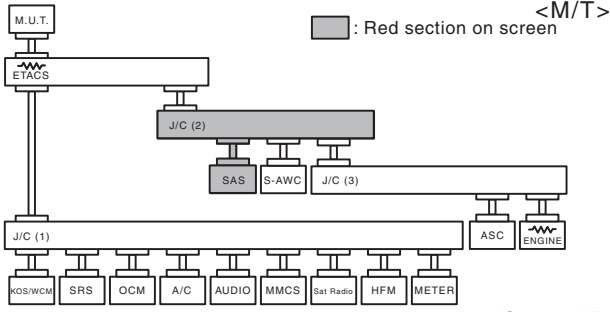
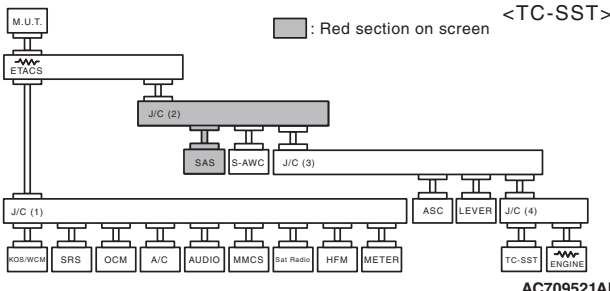
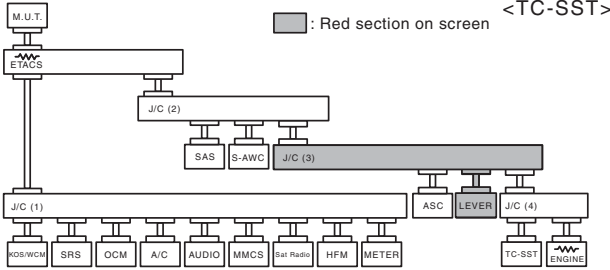
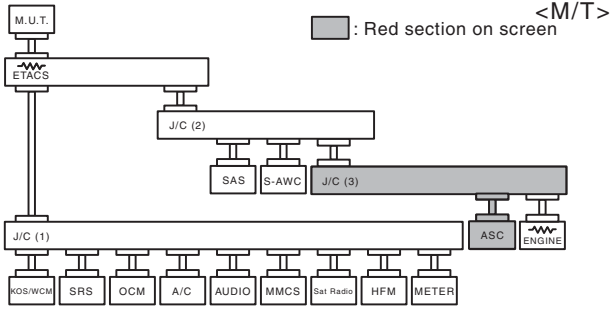
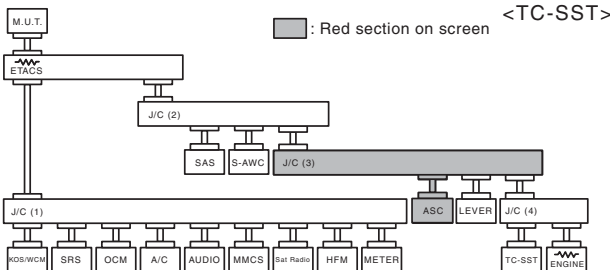
Scan tool screen (The ECUs that are not adopted are not displayed.)	Comment	Diagnosis detail	Reference page
<p>&lt;M/T&gt; ■ : Red section on screen</p>  <p>AC709520AF</p> <p>&lt;TC-SST&gt; ■ : Red section on screen</p>  <p>AC709521AF</p>	<p>CAN-C: Disconnection in red displayed area is estimated.</p>	<p>Diagnosis Item 7 Diagnose when the scan tool cannot receive the data sent by steering wheel sensor.</p>	<p><a href="#">P.54C-101</a></p>
<p>&lt;TC-SST&gt; ■ : Red section on screen</p>  <p>AC709521AG</p>	<p>CAN-C: Disconnection in red displayed area is estimated.</p>	<p>Diagnosis Item 8 Diagnose when the scan tool cannot receive the data sent by shift lever. &lt;TC-SST&gt;</p>	<p><a href="#">P.54C-105</a></p>
<p>&lt;M/T&gt; ■ : Red section on screen</p>  <p>AC709520AG</p> <p>&lt;TC-SST&gt; ■ : Red section on screen</p>  <p>AC709521AH</p>	<p>CAN-C: Disconnection in red displayed area is estimated.</p>	<p>Diagnosis Item 9 Diagnose when the scan tool cannot receive the data sent by ASC-ECU.</p>	<p><a href="#">P.54C-108</a></p>



Scan tool screen (The ECUs that are not adopted are not displayed.)	Comment	Diagnosis detail	Reference page
<p>&lt;M/T&gt; ■ : Red section on screen</p> <p>AC709520AH</p> <p>&lt;TC-SST&gt; ■ : Red section on screen</p> <p>AC709521AI</p>	<p>CAN-C: Disconnection in red displayed area is estimated.</p>	<p>Diagnosis Item 10 Diagnose when the scan tool cannot receive the data sent by ECM.</p>	<p><a href="#">P.54C-112</a></p>
<p>&lt;TC-SST&gt; ■ : Red section on screen</p> <p>AC709521AJ</p>	<p>CAN-C: Disconnection in red displayed area is estimated.</p>	<p>Diagnosis Item 11 Diagnose when the scan tool cannot receive the data sent by TC-SST-ECU. &lt;TC-SST&gt;</p>	<p><a href="#">P.54C-117</a></p>
<p>&lt;M/T&gt; ■ : Red section on screen</p> <p>AC709520AI</p> <p>&lt;TC-SST&gt; ■ : Red section on screen</p> <p>AC709521AK</p>	<p>CAN-C: Disconnection in red displayed area is estimated.</p>	<p>Diagnosis Item 12 Diagnose the lines between the ETACS-ECU and joint connector (CAN2).</p>	<p><a href="#">P.54C-120</a></p>

Scan tool screen (The ECUs that are not adopted are not displayed.)	Comment	Diagnosis detail	Reference page
<p>&lt;M/T&gt; : Red section on screen</p> <p>AC709520AJ</p>	<p>CAN-C: Disconnection in red displayed area is estimated.</p>	<p>Diagnosis Item 13 Diagnose the lines between joint connector (CAN2) and joint connector (CAN3).</p>	<p><a href="#">P.54C-125</a></p>
<p>&lt;TC-SST&gt; : Red section on screen</p> <p>AC709521AL</p>	<p>CAN-C: Disconnection in red displayed area is estimated.</p>	<p>Diagnosis Item 14 Diagnose the lines between joint connector (CAN3) and joint connector (CAN 4). &lt;TC-SST&gt;</p>	<p><a href="#">P.54C-129</a></p>
<p>&lt;M/T&gt; : Red section on screen</p> <p>AC709520AV</p> <p>&lt;TC-SST&gt; : Red section on screen</p> <p>AC709521AY</p>	<p>CAN-B: Disconnection in red displayed area is estimated.</p>	<p>Diagnosis Item 15 Diagnose when the scan tool cannot receive the data sent by KOS-ECU.</p> <p>Diagnosis Item 16 Diagnose when the scan tool cannot receive the data sent by WCM.</p>	<p><a href="#">P.54C-132</a></p> <p><a href="#">P.54C-135</a></p>

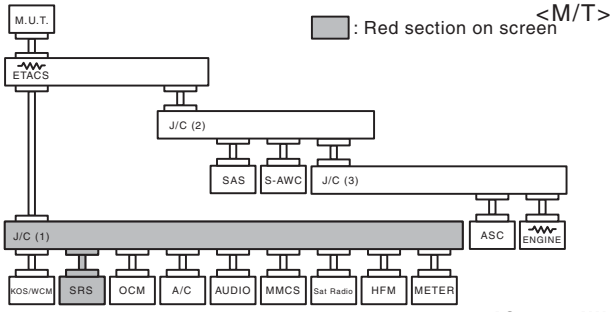
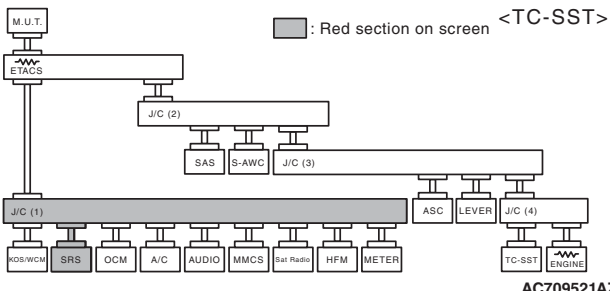
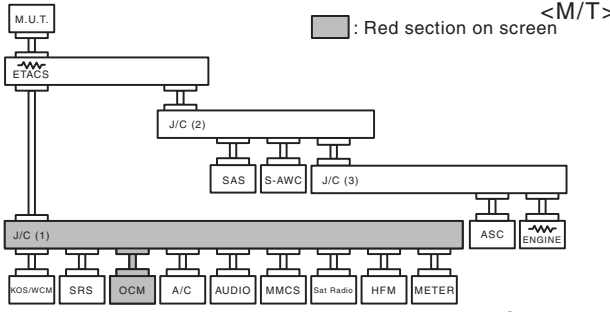
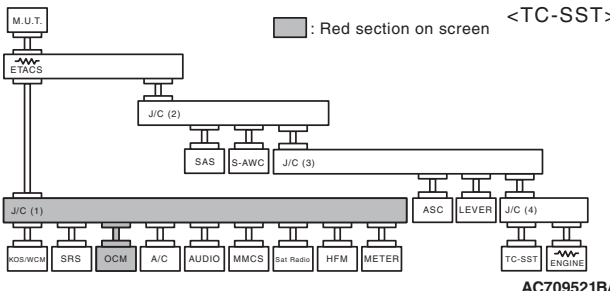

<b>Scan tool screen</b> <b>(The ECUs that are not adopted are not displayed.)</b>	<b>Comment</b>	<b>Diagnosis detail</b>	<b>Reference page</b>
 <p style="text-align: right;">&lt;M/T&gt; : Red section on screen</p> <p style="text-align: right;"><b>AC709520AW</b></p>  <p style="text-align: right;">&lt;TC-SST&gt; : Red section on screen</p> <p style="text-align: right;"><b>AC709521AZ</b></p>	<p>CAN-B: Disconnection in red displayed area is estimated.</p>	<p>Diagnosis Item 17 Diagnose when the scan tool cannot receive the data sent by SRS-ECU.</p>	<p><a href="#">P.54C-138</a></p>
 <p style="text-align: right;">&lt;M/T&gt; : Red section on screen</p> <p style="text-align: right;"><b>AC709520AX</b></p>  <p style="text-align: right;">&lt;TC-SST&gt; : Red section on screen</p> <p style="text-align: right;"><b>AC709521BA</b></p>	<p>CAN-B: Disconnection in red displayed area is estimated.</p>	<p>Diagnosis Item 18 Diagnose when the scan tool cannot receive the data sent by occupant classification-ECU.</p>	<p><a href="#">P.54C-141</a></p>

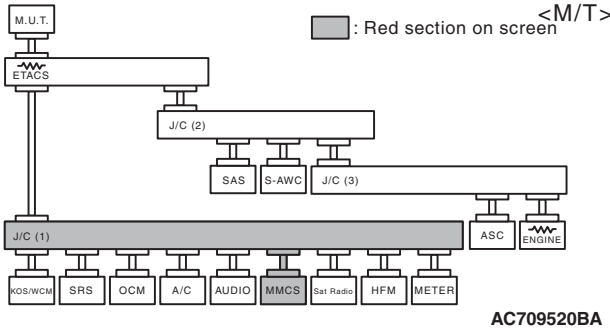
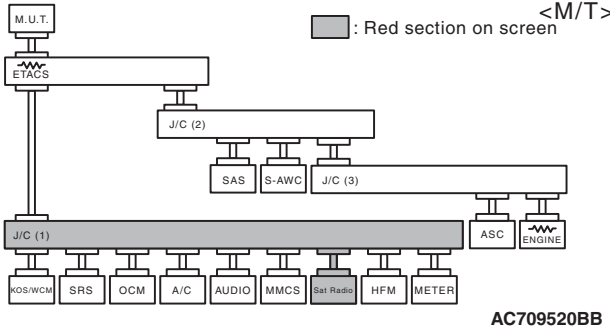
<b>Scan tool screen</b> (The ECUs that are not adopted are not displayed.)	<b>Comment</b>	<b>Diagnosis detail</b>	<b>Reference page</b>
<p style="text-align: right;">&lt;M/T&gt; : Red section on screen</p> <p style="text-align: right;">AC709520AY</p>	<p>CAN-B: Disconnection in red displayed area is estimated.</p>	<p>Diagnosis Item 19 Diagnose when the scan tool cannot receive the data sent by A/C-ECU &lt;vehicles with A/C&gt; or heater control unit &lt;vehicles without A/C&gt;.</p>	<p><a href="#">P.54C-144</a></p>
<p style="text-align: right;">&lt;TC-SST&gt; : Red section on screen</p> <p style="text-align: right;">AC709521BB</p>	<p>CAN-B: Disconnection in red displayed area is estimated.</p>	<p>Diagnosis Item 20 Diagnose when the scan tool cannot receive the data sent by radio and CD player or CD changer.</p>	<p><a href="#">P.54C-147</a></p>
<p style="text-align: right;">&lt;M/T&gt; : Red section on screen</p> <p style="text-align: right;">AC709520AZ</p>	<p>CAN-B: Disconnection in red displayed area is estimated.</p>	<p>Diagnosis Item 20 Diagnose when the scan tool cannot receive the data sent by radio and CD player or CD changer.</p>	<p><a href="#">P.54C-147</a></p>
<p style="text-align: right;">&lt;TC-SST&gt; : Red section on screen</p> <p style="text-align: right;">AC709521BC</p>	<p>CAN-B: Disconnection in red displayed area is estimated.</p>	<p>Diagnosis Item 20 Diagnose when the scan tool cannot receive the data sent by radio and CD player or CD changer.</p>	<p><a href="#">P.54C-147</a></p>

<b>Scan tool screen</b> (The ECUs that are not adopted are not displayed.)	<b>Comment</b>	<b>Diagnosis detail</b>	<b>Reference page</b>
 <p>M.U.T. <span style="float: right;">&lt;M/T&gt;</span>                      ■ : Red section on screen</p> <p>ETACS</p> <p>J/C (2)</p> <p>SAS S-AWC J/C (3)</p> <p>J/C (1)</p> <p>KOS/WCM SRS OCM A/C AUDIO MMCS Sat Radio HFM METER</p> <p>ASC ENGINE</p> <p>AC709520BA</p>	CAN-B: Disconnection in red displayed area is estimated.	Diagnosis Item 21 Diagnose when the scan tool cannot receive the data sent by CAN box unit.	<a href="#">P.54C-150</a>
 <p>M.U.T. <span style="float: right;">&lt;TC-SST&gt;</span>                      ■ : Red section on screen</p> <p>ETACS</p> <p>J/C (2)</p> <p>SAS S-AWC J/C (3)</p> <p>J/C (1)</p> <p>KOS/WCM SRS OCM A/C AUDIO MMCS Sat Radio HFM METER</p> <p>ASC LEVER J/C (4)</p> <p>TC-SST ENGINE</p> <p>AC709521BD</p>	CAN-B: Disconnection in red displayed area is estimated.	Diagnosis Item 22 Diagnose when the scan tool cannot receive the data sent by satellite radio tuner.	<a href="#">P.54C-153</a>
 <p>M.U.T. <span style="float: right;">&lt;M/T&gt;</span>                      ■ : Red section on screen</p> <p>ETACS</p> <p>J/C (2)</p> <p>SAS S-AWC J/C (3)</p> <p>J/C (1)</p> <p>KOS/WCM SRS OCM A/C AUDIO MMCS Sat Radio HFM METER</p> <p>ASC ENGINE</p> <p>AC709520BB</p>	CAN-B: Disconnection in red displayed area is estimated.	Diagnosis Item 22 Diagnose when the scan tool cannot receive the data sent by satellite radio tuner.	<a href="#">P.54C-153</a>
 <p>M.U.T. <span style="float: right;">&lt;TC-SST&gt;</span>                      ■ : Red section on screen</p> <p>ETACS</p> <p>J/C (2)</p> <p>SAS S-AWC J/C (3)</p> <p>J/C (1)</p> <p>KOS/WCM SRS OCM A/C AUDIO MMCS Sat Radio HFM METER</p> <p>ASC LEVER J/C (4)</p> <p>TC-SST ENGINE</p> <p>AC709521BE</p>			

Scan tool screen (The ECUs that are not adopted are not displayed.)	Comment	Diagnosis detail	Reference page
<p>&lt;M/T&gt; : Red section on screen</p> <p>AC709520BC</p> <p>&lt;TC-SST&gt; : Red section on screen</p> <p>AC709521BF</p>	<p>CAN-B: Disconnection in red displayed area is estimated.</p>	<p>Diagnosis Item 23 Diagnose when the scan tool cannot receive the data sent by hands-free module.</p>	<p><a href="#">P.54C-156</a></p>
<p>&lt;M/T&gt; : Red section on screen</p> <p>AC709520BD</p> <p>&lt;TC-SST&gt; : Red section on screen</p> <p>AC709521BG</p>	<p>CAN-B: Disconnection in red displayed area is estimated.</p>	<p>Diagnosis Item 24 Diagnose when the scan tool cannot receive the data sent by combination meter.</p>	<p><a href="#">P.54C-159</a></p>

<b>Scan tool screen</b> (The ECUs that are not adopted are not displayed.)	<b>Comment</b>	<b>Diagnosis detail</b>	<b>Reference page</b>
<p style="text-align: right;">&lt;M/T&gt; : Red section on screen</p> <p style="text-align: right;">&lt;TC-SST&gt; : Red section on screen</p> <p style="text-align: right;">AC709520BE</p> <p style="text-align: right;">AC709521BH</p>	<p>CAN-B: A failure in the red section, or a bus-off failure is present in the gateway ECU.</p>	<p>Diagnosis Item 25 Short to power supply or ground in both CAN_H and CAN_L lines of the CAN-B bus lines.</p>	<p><a href="#">P.54C-162</a></p>
<p style="text-align: right;">&lt;M/T&gt; : Red section on screen</p> <p style="text-align: right;">&lt;TC-SST&gt; : Red section on screen</p> <p style="text-align: right;">AC709520BF</p> <p style="text-align: right;">AC709521BI</p>	<p>CAN-B: Disconnection in red displayed area is estimated.</p>	<p>Diagnosis Item 26 Diagnose the ETACS-ECU, joint connector (CAN1) or lines between ETACS-ECU and joint connector (CAN1).</p>	<p><a href="#">P.54C-205</a></p>

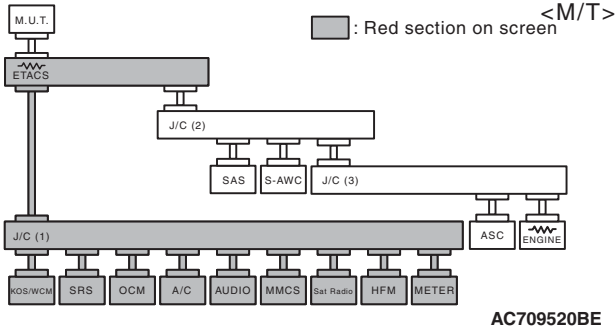
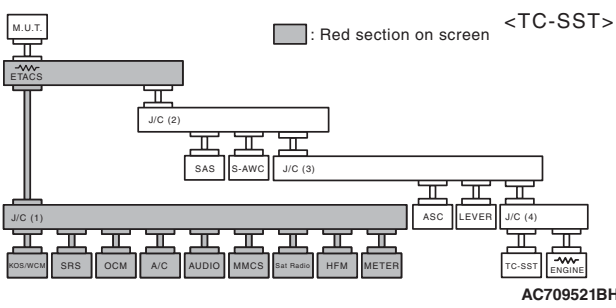
Scan tool screen (The ECUs that are not adopted are not displayed.)	Comment	Diagnosis detail	Reference page
<p><b>&lt;M/T&gt;</b></p>  <p><b>&lt;TC-SST&gt;</b></p> 	<p>CAN-B: Disconnection in red displayed area is estimated.</p>	<p>Diagnosis Item 27 Short to power supply or ground, open circuit or line-to-line short in the CAN-B bus lines.</p>	<p>P.54C-210</p>

**CAN-RELATED CONNECTOR POSITION**

M1548304100146

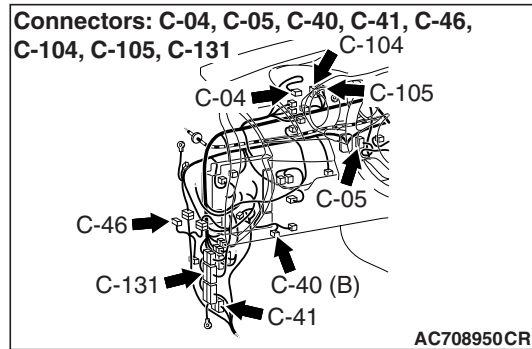
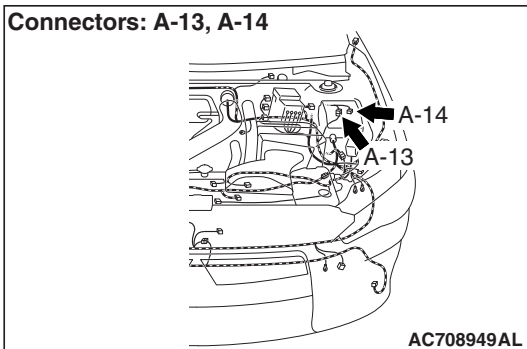
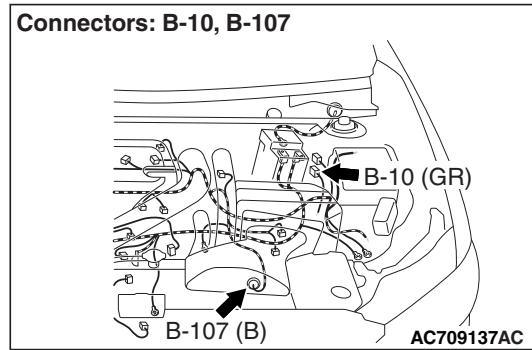
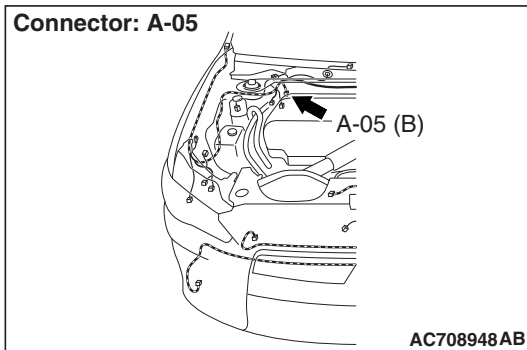

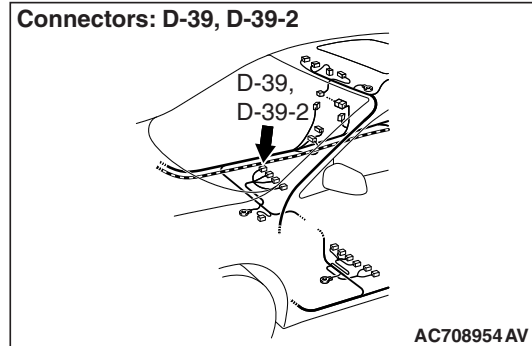
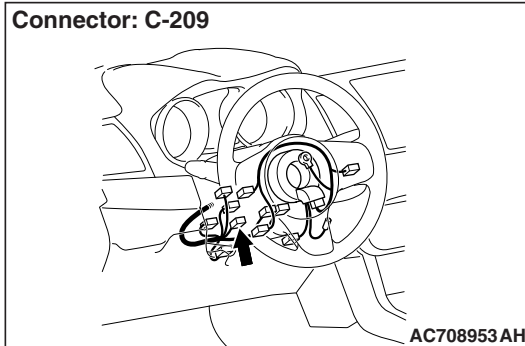
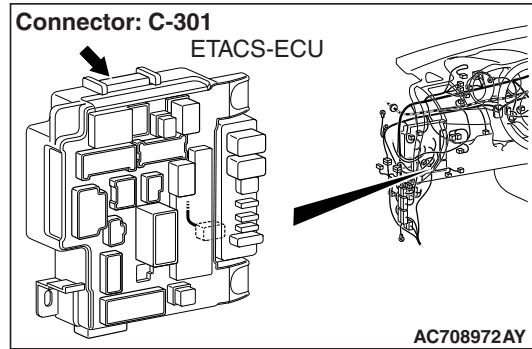
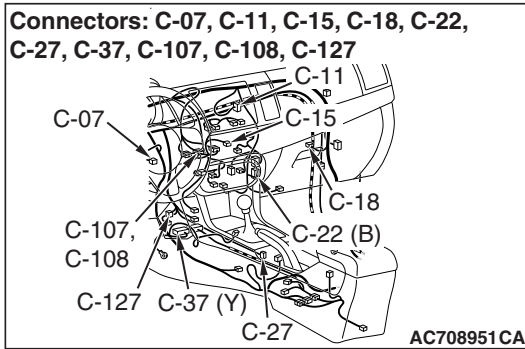

Connector No.	Connector name
A-05	ASC-ECU
A-13	Intermediate connector (Front wiring harness and control wiring harness combination) <TC-SST>
A-14	Joint connector (CAN4) <TC-SST>
B-10	ECM
B-107	Transaxle assembly <TC-SST>
C-04	Combination meter
C-05	KOS-ECU <Vehicles with KOS>
C-07	Wireless control module <Vehicles with WCM>
C-11	Hands free module
C-15	CAN box unit <Vehicles with MMCS>
C-18	Satellite radio tuner
C-22	A/C-ECU
C-27	Shift lever <TC-SST>
C-37	SRS-ECU
C-40	Data link connector
C-41	Intermediate connector (Instrument panel wiring harness and floor wiring harness combination)

Connector No.	Connector name
C-46	AWC-ECU
C-53	Heater control unit
C-104	Joint connector (CAN2)
C-105	Joint connector (CAN1)
C-107	Radio and CD player <Vehicles without MMCS>
C-108	Intermediate connector (Instrument panel wiring harness and multivision display wiring harness combination) <Vehicles with MMCS>
C-127	Joint connector (CAN3)
C-131	Intermediate connector (Instrument panel wiring harness and front wiring harness combination)
C-209	Steering wheel sensor
C-301	ETACS-ECU
D-39	Front seat assembly (LH)
D-39-2	Occupant classification-ECU

CAN BUS DIAGNOSTICS

DIAGNOSTIC ITEM 1: Diagnose when the scan tool cannot receive the data sent by ETACS-ECU.

**CAUTION**

When servicing a CAN bus line, ground yourself by touching a metal object such as an unpainted water pipe. If you fail to do so, a component connected to the CAN bus line may be damaged.

Diagnosis CAN Communication Circuit

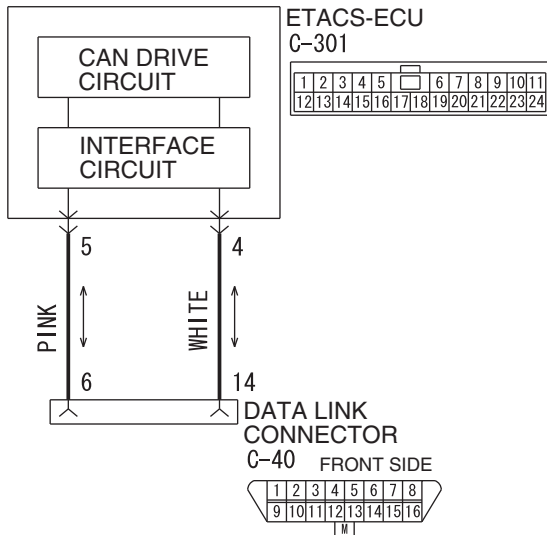

W8G54M187A

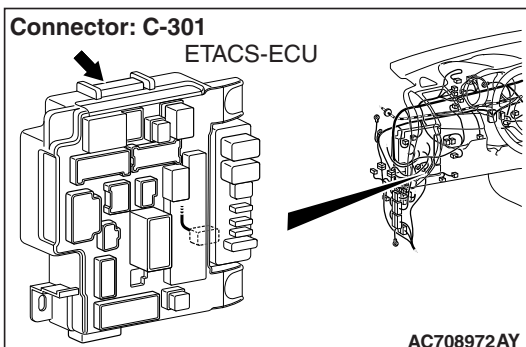
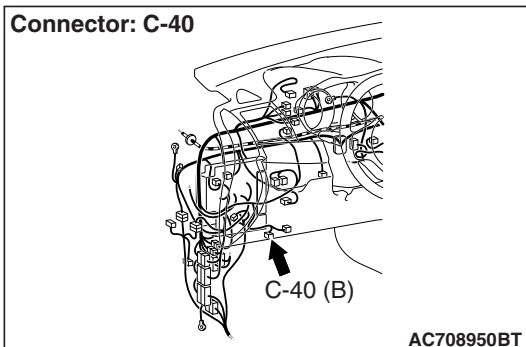

**FUNCTION**

When the CAN bus diagnosis is carried out, the scan tool communicates with the ETACS-ECU. If a communication flag is not set for the ETACS-ECU, the ETACS-ECU will be diagnosed as a communication error.

**TROUBLE JUDGMENT CONDITIONS**

If a communication flag is not set for the ETACS-ECU, the scan tool determines that there is a failure.

**TROUBLESHOOTING HINTS**

- Malfunction of the connector (data link connector or ETACS-ECU connector improperly connected)
- Malfunction of the wiring harness (open circuit, short to ground, short to power supply between the data link connector and the ETACS-ECU connector, line-to-line short, or power supply to the ETACS-ECU)
- Malfunction of ETACS-ECU



## DIAGNOSIS

### Required Special Tools:

- MB991223: Harness Set
- MB992006: Extra Fine Probe
- MB991958: Scan Tool (M.U.T.-III Sub Assembly)
  - MB991824: Vehicle Communication Interface (V.C.I.)
  - MB991827: M.U.T.-III USB Cable
  - MB991910: M.U.T.-III Main Harness A

**STEP 1. Check data link connector C-40 and ETACS-ECU connector C-301 for loose, corroded or damaged terminals, or terminals pushed back in the connector.**

#### **⚠ CAUTION**

The strand end of the twisted wire should be within 10 cm (4 inches) from the connector. For details refer to [P.54C-7](#).

**Q: Are data link connector C-40 and ETACS-ECU connector C-301 in good condition?**

**YES :** Go to Step 2.

**NO :** Repair the damaged parts.

**STEP 2. Check the wiring harness between data link connector C-40 and ETACS-ECU connector C-301 for open circuit.**

#### **⚠ CAUTION**

Strictly observe the specified wiring harness repair procedure. For details refer to [P.54C-7](#).

- (1) Disconnect the scan tool and ETACS-ECU connector C-301, and check the wiring harness.
- (2) Check the wiring harness between data link connector C-40 (terminal 6) and ETACS-ECU connector C-301 (terminal 5) <CAN\_H>

**OK: Continuity exists (2 Ω or less)**

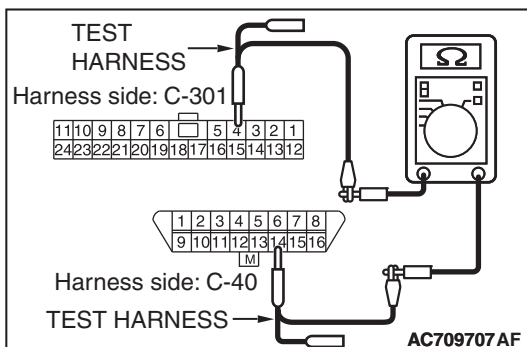
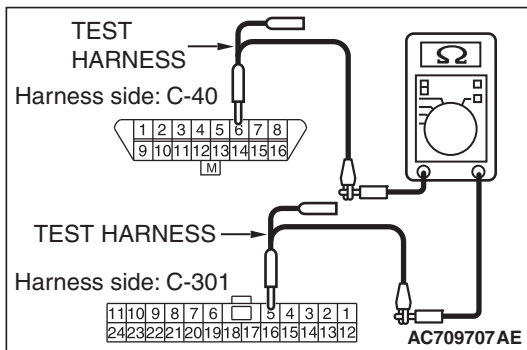

- (3) Check the wiring harness between data link connector C-40 (terminal 14) and ETACS-ECU connector C-301 (terminal 4) <CAN\_L>

**OK: Continuity exists (2 Ω or less)**

**Q: Is the wiring harness between data link connector C-40 and ETACS-ECU connector C-301 in good condition?**

**YES :** Go to Step 3.

**NO :** Repair the wiring harness between data link connector C-40 and ETACS-ECU connector C-301.

**STEP 3. Check the wiring harness between data link connector C-40 and ETACS-ECU connector C-301 for a short to ground. Measure the resistance at data link connector C-40.**

**⚠ CAUTION**

Disconnect the negative battery terminal. For details refer to P.54C-7.

**⚠ CAUTION**

A digital multimeter should be used. For details refer to P.54C-7.

**⚠ CAUTION**

The test wiring harness should be used. For details refer to P.54C-7.

- (1) Disconnect the scan tool and ETACS-ECU connector C-301, and measure the resistance at the wiring harness side of data link connector C-40.
- (2) Measure the resistance between data link connector terminal 6 and body ground. <CAN\_H>

**OK: 1 k $\Omega$  or more**

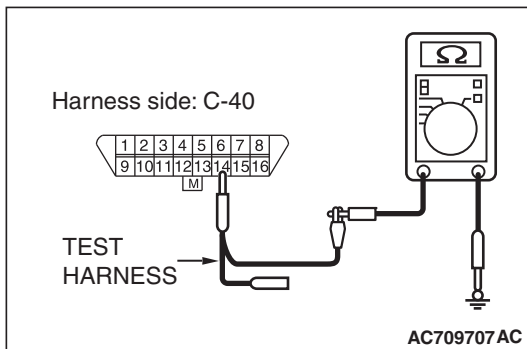
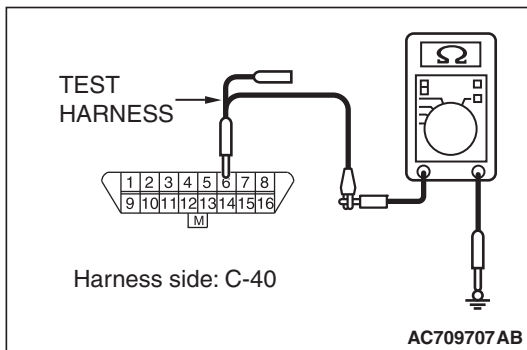

- (3) Measure the resistance between data link connector terminal 14 and body ground. <CAN\_L>

**OK: 1 k $\Omega$  or more**

**Q: Do all the resistances measure 1 k $\Omega$  or more?**

**YES :** Go to Step 4.

**NO :** Repair the wiring harness between data link connector C-40 and ETACS-ECU connector C-301.

**STEP 4. Check the wiring harness between data link connector C-40 and ETACS-ECU connector C-301 for a short to the power supply. Measure the voltage at data link connector C-40.**

- (1) Disconnect the scan tool and ETACS-ECU connector C-301, and measure the resistance at the wiring harness side of data link connector C-40.
- (2) Turn the ignition switch to the "ON" position.
- (3) Measure the voltage between data link connector terminal 6 and body ground. <CAN\_H>

**OK: 1 V or less**

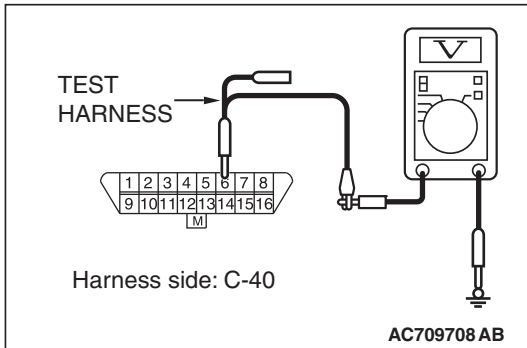

- (4) Measure the voltage between data link connector terminal 14 and body ground. <CAN\_L>

**OK: 1 V or less**

**Q: Do all the voltage measure 1 V or less?**

**YES :** Go to Step 5.

**NO :** Repair the wiring harness between data link connector C-40 and ETACS-ECU connector C-301.

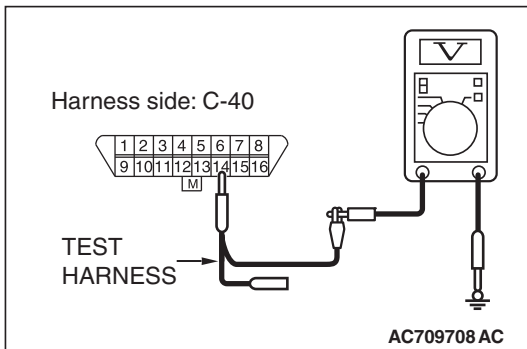

**STEP 5. Check the wiring harness between data link connector C-40 and ETACS-ECU connector C-301 for line-to-line short. Measure the resistance at data link connector C-40.**

- (1) Disconnect the scan tool and ETACS-ECU connector C-301, and measure the resistance at the wiring harness side of data link connector C-40.
- (2) Measure the resistance between data link connector terminal 6 and 14.

**OK: No continuity**

**Q: Is the check result normal?**

**YES :** Go to Step 6.

**NO :** Repair the wiring harness between data link connector C-40 and ETACS-ECU connector C-301.

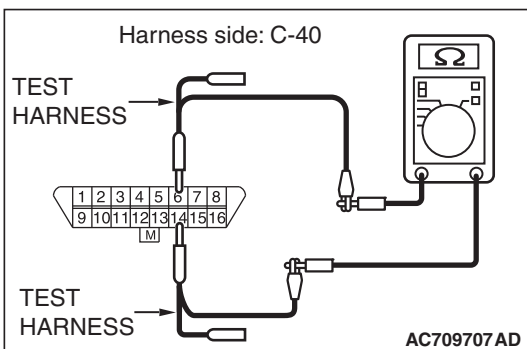

**STEP 6.** Using scan tool MB991958, diagnose the CAN bus line.

**⚠ CAUTION**

To prevent damage to scan tool MB991958, always turn the ignition switch to the "LOCK" (OFF) position before connecting or disconnecting scan tool MB991958.

- (1) Connect scan tool MB991958 to the data link connector.
- (2) Turn the ignition switch to the "ON" position.

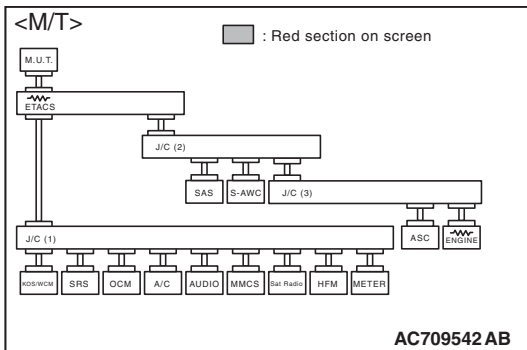
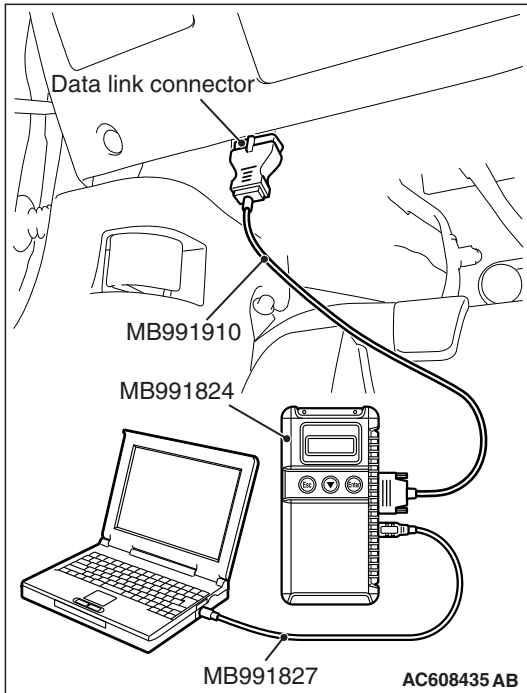

- (3) Diagnose CAN bus lines, and check if the scan tool screen is as shown in the illustration.

**Q: Does the scan tool screen correspond to the illustration?**

**YES :** The trouble can be an intermittent malfunction (Refer to GROUP 00, How to use Troubleshooting/inspection Service Points –How to Cope with Intermittent Malfunction P.00-15).

**NO :** Replace the ETACS-ECU.

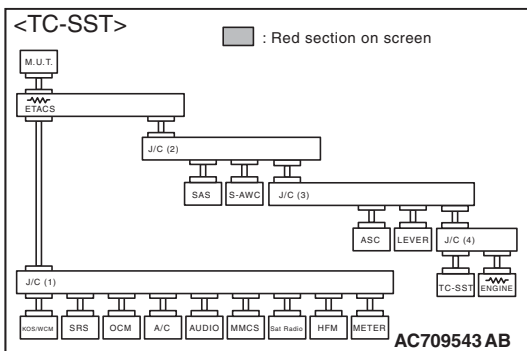

**DIAGNOSTIC ITEM 2: Malfunction of the ETACS-ECU.**

**CAUTION**

When servicing a CAN bus line, ground yourself by touching a metal object such as an unpainted water pipe. If you fail to do, a component connected to the CAN bus line may be broken.

**FUNCTION**

When the CAN bus diagnosis is carried out, the scan tool sets communication "OK" flags in the patch between the ETACS-ECU and active other ECUs. If a communication "OK" flag is not set for the ECUs other than the ETACS-ECU, this diagnosis result will be set.

**TROUBLE JUDGEMENT CONDITIONS**

If no communication flags are set for the ECUs (on the CAN-B or CAN-C lines) other than the ETACS-ECU, the ETACS-ECU determines that there is a failure.

**TROUBLESHOOTING HINT**

Malfunction of the ETACS-ECU

**DIAGNOSIS**

**Required Special Tools:**

- MB991958: Scan Tool (M.U.T.-III Sub Assembly)
  - MB991824: Vehicle Communication Interface (V.C.I.)
  - MB991827: M.U.T.-III USB Cable
  - MB991910: M.U.T.-III Main Harness A

**Recheck for other system diagnostic trouble code.**

**CAUTION**

To prevent damage to scan tool MB991958, always turn the ignition switch to the "LOCK" (OFF) position before connecting or disconnecting scan tool MB991958.

Check whether ETACS-ECU-related DTC is set.

- (1) Connect scan tool MB991958 to the data link connector.
- (2) Turn the ignition switch to the "ON" position.
- (3) Check if the DTC is set.
- (4) Turn the ignition switch to the "LOCK" (OFF) position.

**Q: Is the DTC set?**

**YES (The DTC other than the U code is set.) :**

Troubleshoot the ETACS-ECU. Refer to GROUP 54A, ETACS-ECU P.54A-646.

**YES (Only U-code DTC is set.) :** Check the power supply circuit of the ETACS-ECU. Refer to GROUP 54A, ETACS-ECU P.54A-699.

**NO (The DTC is not set.) :** Check the power supply circuit of the ETACS-ECU. Refer to GROUP 54A, ETACS-ECU P.54A-699.

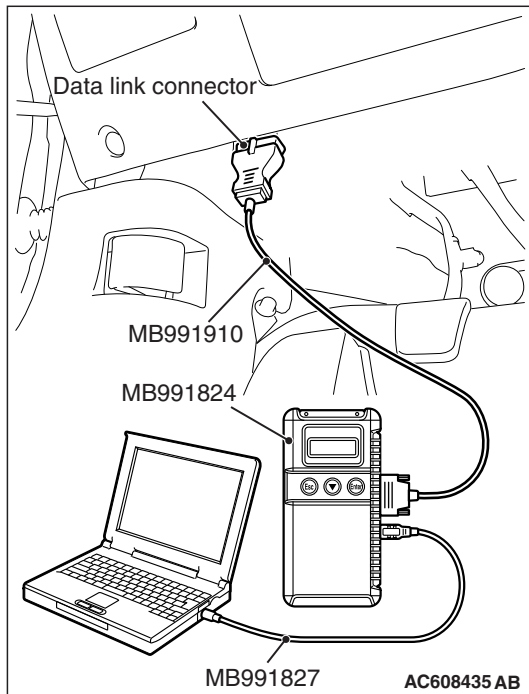

DIAGNOSTIC ITEM 3: Abnormal short between the CAN-C bus lines.

**CAUTION**

When servicing a CAN bus line, ground yourself by touching a metal object such as an unpainted water pipe. If you fail to do so, a component connected to the CAN bus line may be damaged.

CAN-C Communication Circuit <M/T>

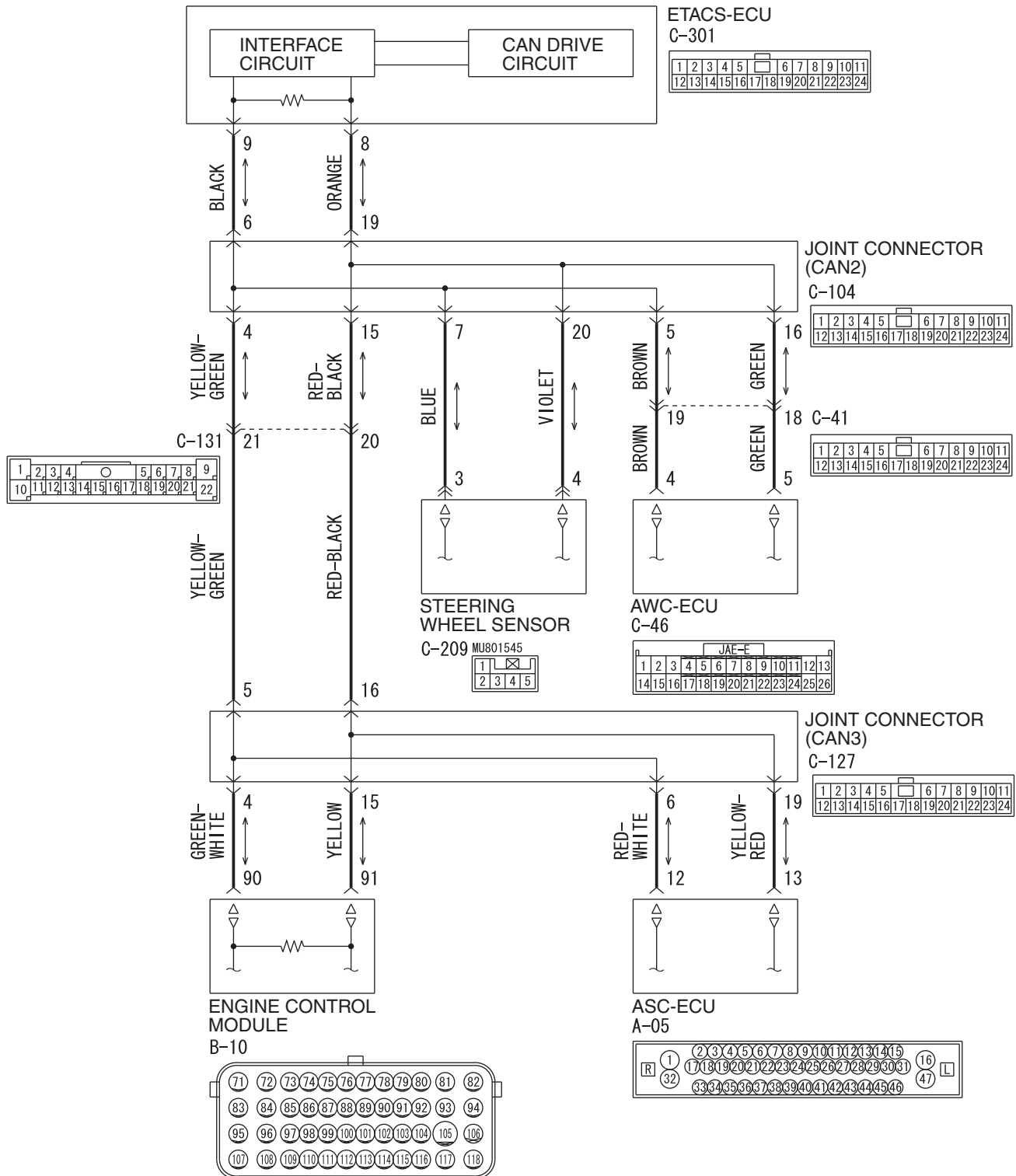

CAN-C Communication Circuit <TC-SST>

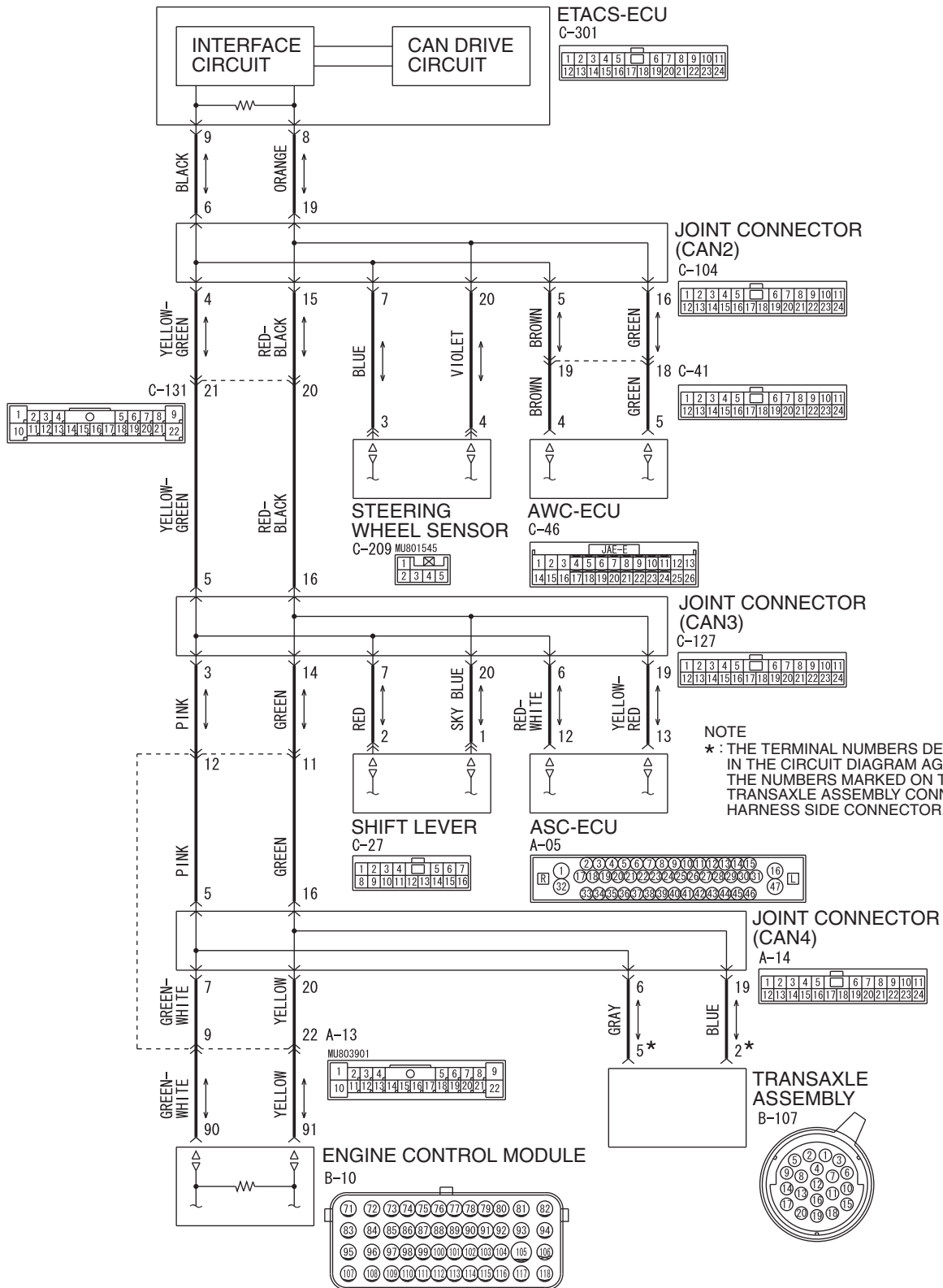

Connector: A-05

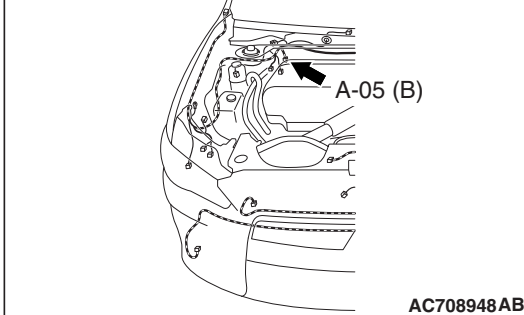

Connectors: C-46, C-104

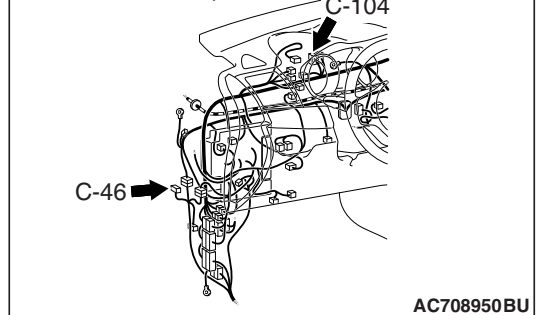

Connector: A-14

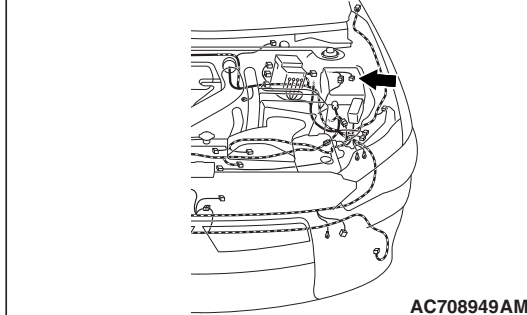

Connector: C-209

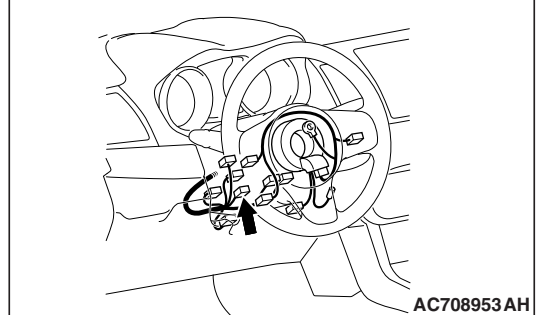

Connectors: B-10, B-107

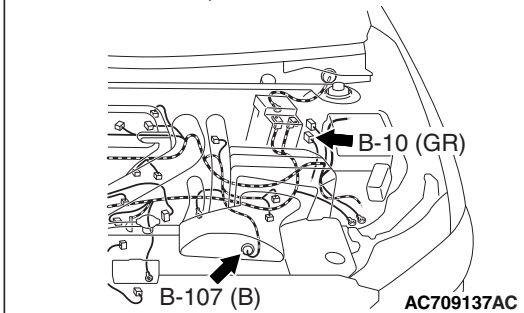

Connector: C-301

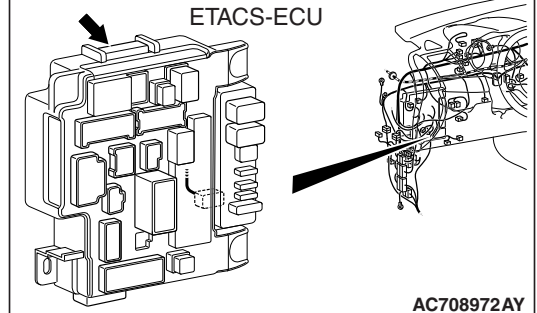

Connectors: C-27, C-127

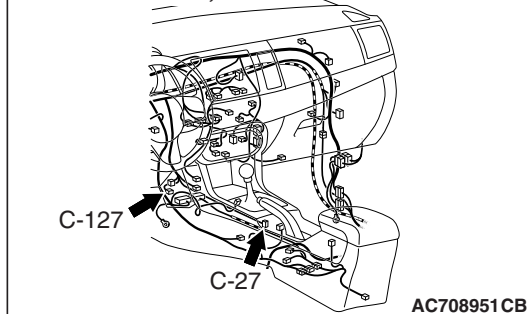
**FUNCTION**

If a line-to-line short is present in the CAN-C lines, this diagnosis result will be set.

**TROUBLE JUDGMENT CONDITIONS**

If only diagnostic trouble code U0001 is set, the ETACS-ECU determines that there is a failure.

**TROUBLESHOOTING HINTS**

- Malfunction of the connector (joint connectors or ECU connectors improperly connected)
- Malfunction of the wiring harness (line-to-line short in the CAN-C main or sub bus lines)
- Malfunction of the ECU (ECU on CAN-C lines failed)



## DIAGNOSIS

### Required Special Tools:

- MB991223: Harness Set
- MB992006: Extra Fine Probe
- MB991958: Scan Tool (M.U.T.-III Sub Assembly)
  - MB991824: Vehicle Communication Interface (V.C.I.)
  - MB991827: M.U.T.-III USB Cable
  - MB991910: M.U.T.-III Main Harness A
- MB992110: Power plant ECU check harness
- MB991997: ASC Check Harness

**STEP 1. Check joint connector (CAN2) C-104, joint connector (CAN3) C-127 and joint connector (CAN4) A-14 <TC-SST> for loose, corroded or damaged terminals, or terminals pushed back in the connector.**

#### **⚠ CAUTION**

The strand end of the twisted wire should be within 10 cm (4 inches) from the connector. For details refer to [P.54C-7](#).

**Q: Are joint connector (CAN2) C-104, joint connector (CAN3) C-127 and joint connector (CAN4) A-14 in good condition?**

**YES :** Go to Step 2.

**NO :** Repair the damaged parts.

**STEP 2. Check the wiring harness between joint connector (CAN2) C-104 and steering wheel sensor connector C-209 for line-to-line short. Measure the resistance at joint connector (CAN2) C-104.**

#### **⚠ CAUTION**

A digital multimeter should be used. For details refer to [P.54C-7](#).

#### **⚠ CAUTION**

The test wiring harness should be used. For details refer to [P.54C-7](#).

- (1) Disconnect joint connector (CAN2), and check that there is continuity at the harness side of joint connector (CAN2).
- (2) Check that there is continuity between joint connector (CAN2) terminals 7 and 20.

**OK: No continuity**

**Q: Is the check result normal?**

**YES :** Go to Step 3.

**NO :** Go to Step 11.

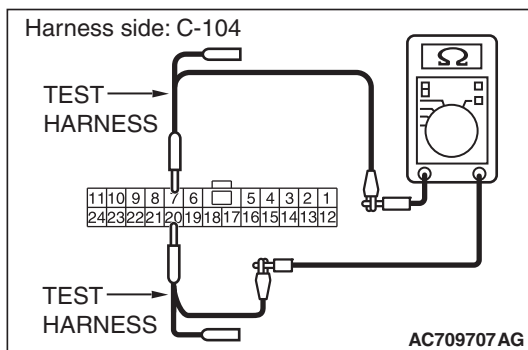

**STEP 3.** Check the wiring harness between joint connector (CAN2) C-104 and S-AWC-ECU connector C-46 for line-to-line short. Measure the resistance at joint connector (CAN2) C-104.

**⚠ CAUTION**

A digital multimeter should be used. For details refer to P.54C-7.

**⚠ CAUTION**

The test wiring harness should be used. For details refer to P.54C-7.

- (1) Disconnect joint connector (CAN2), and check that there is continuity at the harness side of joint connector (CAN2).
- (2) Check that there is continuity between joint connector (CAN2) terminals 5 and 16.

**OK: No continuity**

**Q: Is the check result normal?**

**YES :** Go to Step 4.

**NO :** Go to Step 12.

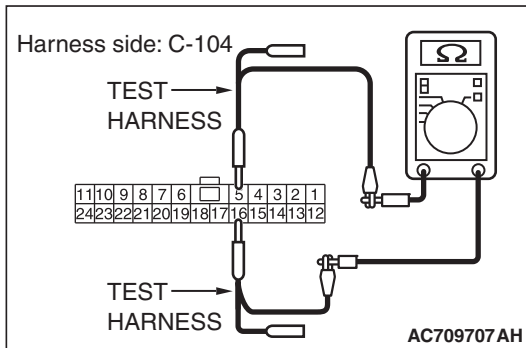

**STEP 4.** Check the wiring harness between joint connector (CAN2) C-104 and ETACS-ECU connector C-301 for line-to-line short. Measure the resistance at joint connector (CAN2) C-104.

**⚠ CAUTION**

A digital multimeter should be used. For details refer to P.54C-7.

**⚠ CAUTION**

The test wiring harness should be used. For details refer to P.54C-7.

- (1) Disconnect joint connector (CAN2), and check that there is continuity at the harness side of joint connector (CAN2).
- (2) Check that there is continuity between joint connector (CAN2) terminals 6 and 19.

**OK:  $120 \pm 20 \Omega$**

**Q: Is the check result normal?**

**YES :** Go to Step 5.

**NO :** Go to Step 13.

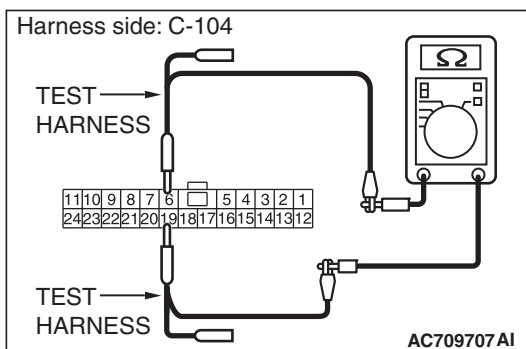

**STEP 5.** Check the wiring harness between joint connector (CAN3) C-127 and ASC-ECU connector A-05 for line-to-line short. Measure the resistance at joint connector (CAN3) C-127.

**CAUTION**

A digital multimeter should be used. For details refer to P.54C-7.

**CAUTION**

The test wiring harness should be used. For details refer to P.54C-7.

- (1) Disconnect joint connector (CAN3), and check that there is continuity at the harness side of joint connector (CAN3).
- (2) Check that there is continuity between joint connector (CAN3) terminals 6 and 19.

**OK: No continuity**

**Q: Is the check result normal?**

**YES <M/T> :** Go to Step 6.

**YES <TC-SST> :** Go to Step 7.

**NO :** Go to Step 14.

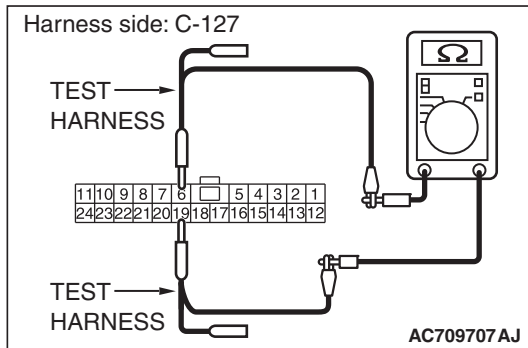

**STEP 6.** Check the wiring harness between joint connector (CAN3) C-127 and ECM connector B-10 <M/T> for line-to-line short. Measure the resistance at joint connector (CAN3) C-127.

**CAUTION**

A digital multimeter should be used. For details refer to P.54C-7.

**CAUTION**

The test wiring harness should be used. For details refer to P.54C-7.

- (1) Disconnect joint connector (CAN3), and check that there is continuity at the harness side of joint connector (CAN3).
- (2) Check that there is continuity between joint connector (CAN3) terminals 4 and 15.

**OK: 120 ± 20 Ω**

**Q: Is the check result normal?**

**YES :** Check intermediate connector C-131, and repair if necessary. If the intermediate connector is in good condition, repair the wiring harness between joint connector (CAN2) C-104 and joint connector (CAN3) C-127.

**NO :** Go to Step 15.

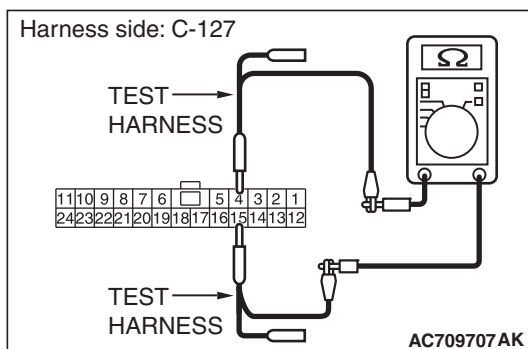

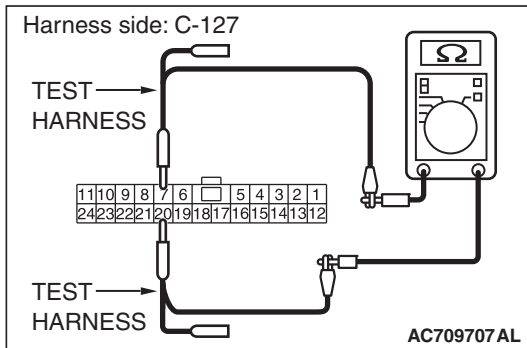

**STEP 7.** Check the wiring harness between joint connector (CAN3) C-127 and shift lever connector for line-to-line short. Measure the resistance at joint connector (CAN3) C-127.

**⚠ CAUTION**

A digital multimeter should be used. For details refer to P.54C-7.

**⚠ CAUTION**

The test wiring harness should be used. For details refer to P.54C-7.

- (1) Disconnect joint connector (CAN3), and check that there is continuity at the harness side of joint connector (CAN3).
- (2) Check that there is continuity between joint connector (CAN3) terminals 7 and 20.

**OK: No continuity**

**Q: Is the check result normal?**

**YES :** Go to Step 8.

**NO :** Go to Step 16.

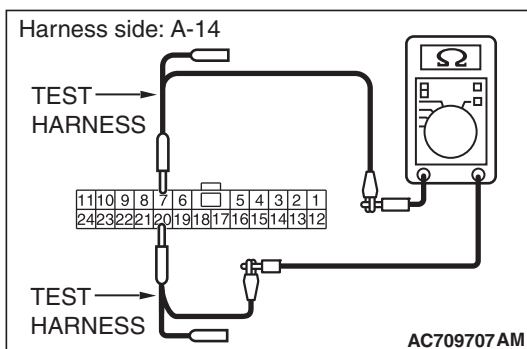

**STEP 8.** Check the wiring harness between joint connector (CAN4) A-14 and ECM connector B-10 <TC-SST> for line-to-line short. Measure the resistance at joint connector (CAN4) A-14.

**⚠ CAUTION**

A digital multimeter should be used. For details refer to P.54C-7.

**⚠ CAUTION**

The test wiring harness should be used. For details refer to P.54C-7.

- (1) Disconnect joint connector (CAN4), and check that there is continuity at the harness side of joint connector (CAN4).
- (2) Check that there is continuity between joint connector (CAN4) terminals 7 and 20.

**OK: No continuity**

**Q: Is the check result normal?**

**YES :** Go to Step 9.

**NO :** Go to Step 15.

**STEP 9.** Check the wiring harness between joint connector (CAN4) A-14 and transaxle assembly connector B-107 for line-to-line short. Measure the resistance at joint connector (CAN4) A-14.

**CAUTION**

A digital multimeter should be used. For details refer to P.54C-7.

**CAUTION**

The test wiring harness should be used. For details refer to P.54C-7.

- (1) Disconnect joint connector (CAN4), and check that there is continuity at the harness side of joint connector (CAN4).
- (2) Check that there is continuity between joint connector (CAN4) terminals 6 and 19.

**OK: No continuity**

**Q: Is the check result normal?**

**YES :** Go to Step 10.

**NO :** Go to Step 17.

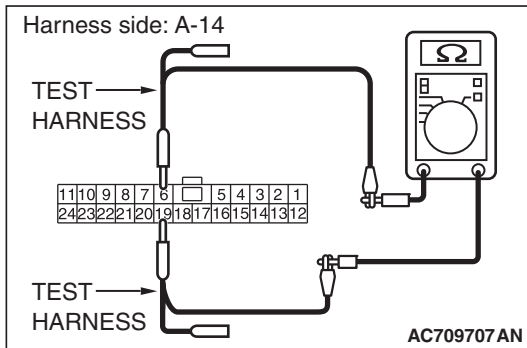

**STEP 10.** Check the wiring harness between joint connector (CAN3) C-127 and joint connector (CAN2) C-104 for line-to-line short. Measure the resistance at joint connector (CAN3) C-127.

**CAUTION**

A digital multimeter should be used. For details refer to P.54C-7.

**CAUTION**

The test wiring harness should be used. For details refer to P.54C-7.

Disconnect joint connector (CAN3) and Disconnect joint connector (CAN2), and check that there is continuity at the harness side of joint connector (CAN3).

- (1) Check that there is continuity between joint connector (CAN3) terminals 5 and 16.

**OK: No continuity**

**Q: Is the check result normal?**

**YES :** Check intermediate connector A-13, and repair if necessary. If the intermediate connector is in good condition, repair the wiring harness between joint connector (CAN3) C-127 and joint connector (CAN4) A-14.

**NO :** Check intermediate connector C-131, and repair if necessary. If the intermediate connector is in good condition, repair the wiring harness between joint connector (CAN2) C-104 and joint connector (CAN3) C-127.

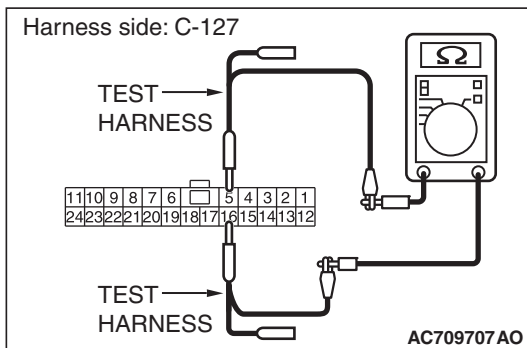

**STEP 11.** Using scan tool MB991958, diagnose the CAN bus line. (checking the steering wheel sensor for internal short)

**⚠ CAUTION**

Strictly observe the specified wiring harness repair procedure. For details refer to [P.54C-7](#).

**⚠ CAUTION**

To prevent damage to scan tool MB991958, always turn the ignition switch to the "LOCK" (OFF) position before connecting or disconnecting scan tool MB991958.

- (1) Disconnect steering wheel sensor connector C-209.
- (2) Connect scan tool MB991958 to the data link connector.
- (3) Turn the ignition switch to the "ON" position.

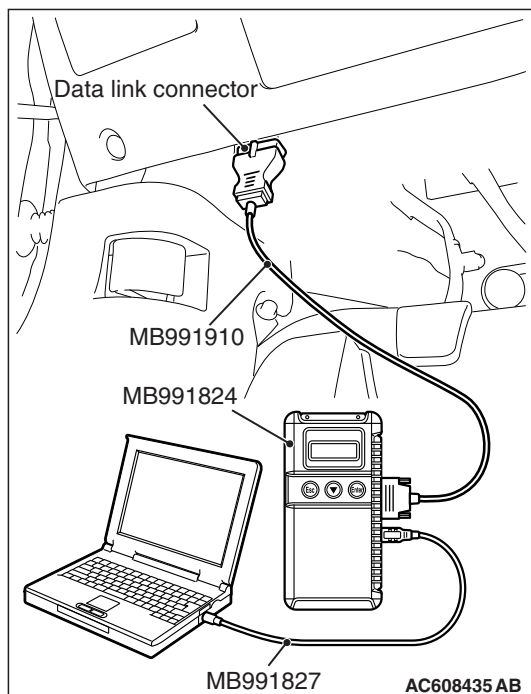

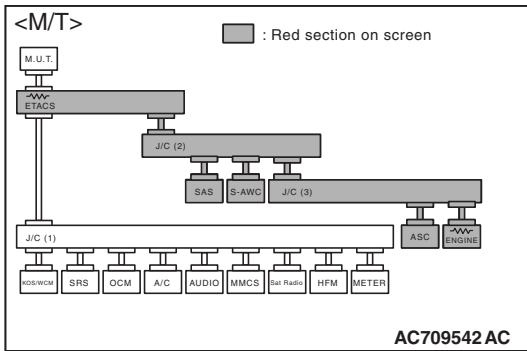

(4) Diagnose CAN bus lines, and check if the scan tool MB991958 screen is as shown in the figure.

**OK:** The display of the scan tool MB991958 is as shown in the figure.

**Q:** Does scan tool MB991958 screen correspond to the illustration?

**YES :** Repair the wiring harness between steering wheel sensor connector C-209 and joint connector (CAN2) C-104.

**NO :** Check steering wheel sensor connector C-209, and repair if necessary. If the steering wheel sensor connector is in good condition, replace the steering wheel sensor.

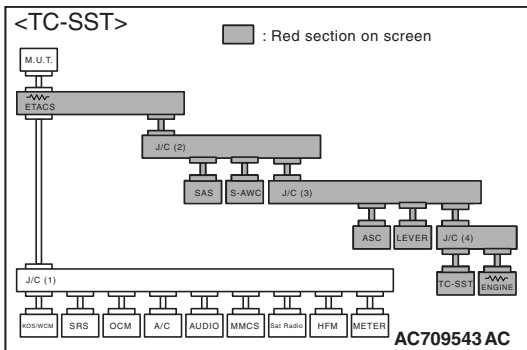

**STEP 12.** Using scan tool MB991958, diagnose the CAN bus line. (checking the S-AWC-ECU for internal short)

**CAUTION**

Strictly observe the specified wiring harness repair procedure. For details refer to P.54C-7.

**CAUTION**

To prevent damage to scan tool MB991958, always turn the ignition switch to the "LOCK" (OFF) position before connecting or disconnecting scan tool MB991958.

- (1) Disconnect S-AWC-ECU connector C-46.
- (2) Connect scan tool MB991958 to the data link connector.
- (3) Turn the ignition switch to the "ON" position.

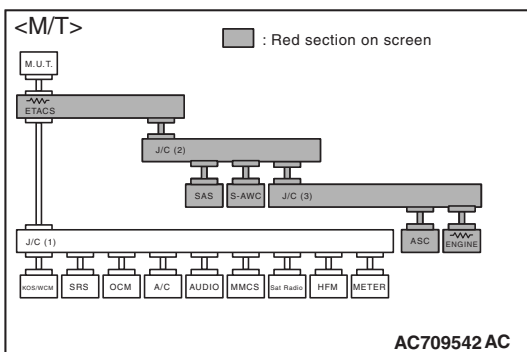
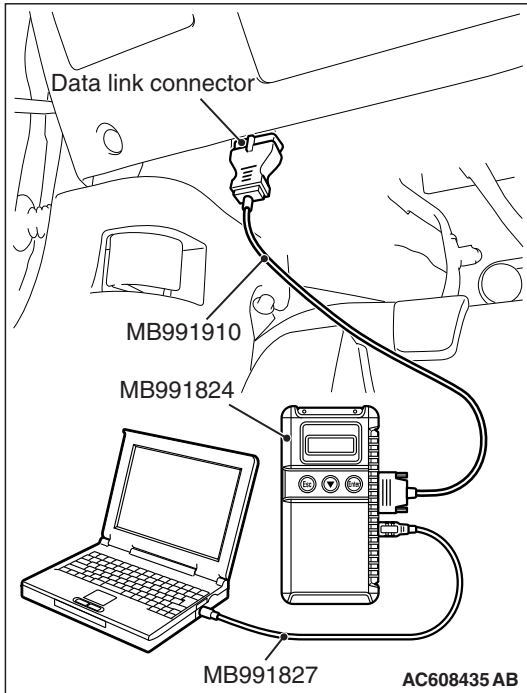

- (4) Diagnose CAN bus lines, and check if the scan tool MB991958 screen is as shown in the figure.

**OK:** The display of the scan tool MB991958 is as shown in the figure.

**Q:** Does scan tool MB991958 screen correspond to the illustration?

**YES :** Repair the wiring harness between S-AWC-ECU connector C-46 and joint connector (CAN2) C-104.

**NO :** Check S-AWC-ECU connector C-46, and repair if necessary. If the S-AWC-ECU connector is in good condition, replace the S-AWC-ECU.

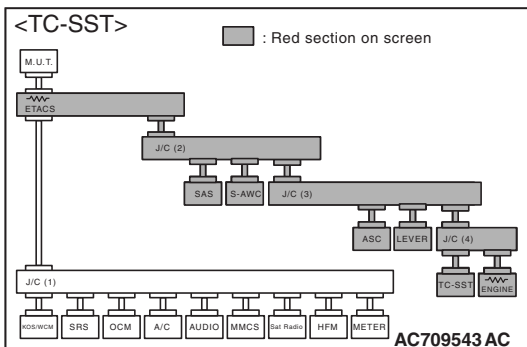



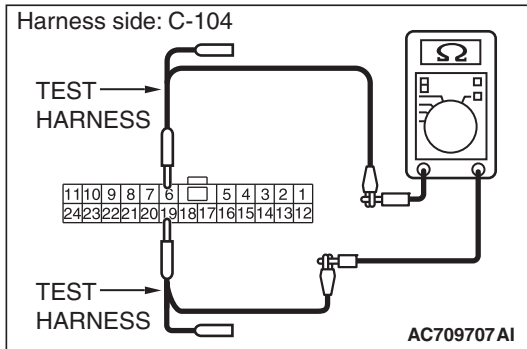

**STEP 13. Check the wiring harness between joint connector (CAN2) C-104 and ETACS-ECU connector C-301 for line-to-line short. Measure the resistance at joint connector (CAN2) C-104.**

- (1) Disconnect joint connector (CAN2) and ETACS-ECU connector, and check that there is continuity at the harness side of joint connector (CAN2).
- (2) Check that there is continuity between joint connector (CAN2) terminals 6 and 19.

**OK: No continuity**

**Q: Is the check result normal?**

**YES :** Go to Step 18.

**NO :** Repair the wiring harness between ETACS-ECU connector C-301 and joint connector (CAN2) C-104.

**STEP 14. Using scan tool MB991958, diagnose the CAN bus line. (checking the ASC-ECU for internal short)**

**CAUTION**

Strictly observe the specified wiring harness repair procedure. For details refer to [P.54C-7](#).

**CAUTION**

To prevent damage to scan tool MB991958, always turn the ignition switch to the "LOCK" (OFF) position before connecting or disconnecting scan tool MB991958.

- (1) Disconnect ASC-ECU connector A-05.
- (2) Connect scan tool MB991958 to the data link connector.
- (3) Turn the ignition switch to the "ON" position.

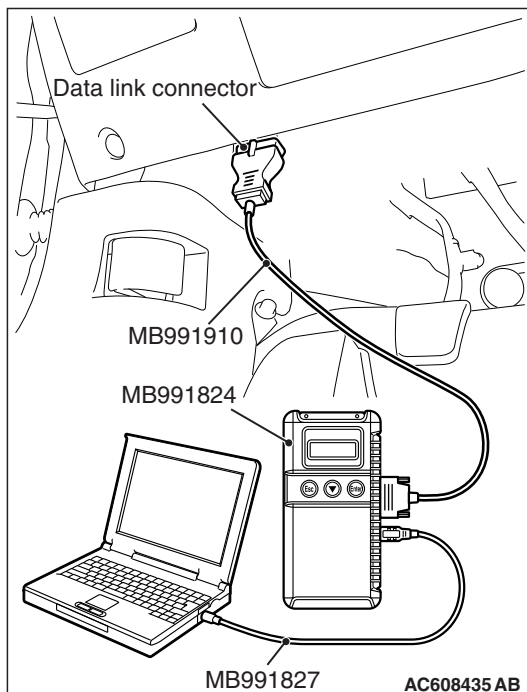

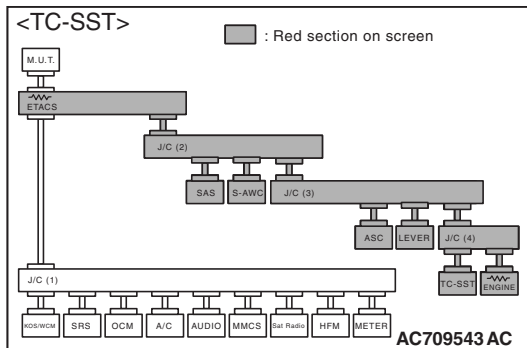
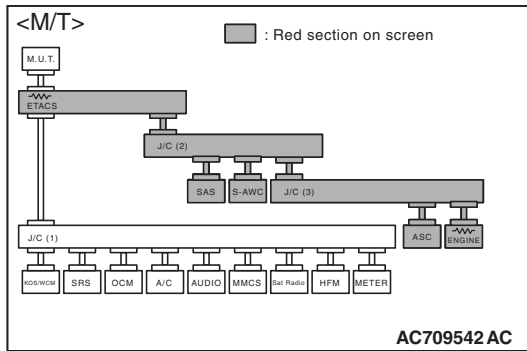

- (4) Diagnose CAN bus lines, and check if the scan tool MB991958 screen is as shown in the figure.

**OK:** The display of the scan tool MB991958 is as shown in the figure.

- Q:** Does scan tool MB991958 screen correspond to the illustration?

**YES :** Repair the wiring harness between ASC-ECU connector A-05 and joint connector (CAN3) C-127.

**NO :** Check ASC-ECU connector A-05, and repair if necessary. If the ASC-ECU connector is in good condition, replace the ASC-ECU.

**STEP 15. Using scan tool MB991958, diagnose the CAN bus line. (checking the ECM for internal short)**

**⚠ CAUTION**

Strictly observe the specified wiring harness repair procedure. For details refer to [P.54C-7](#).

**⚠ CAUTION**

To prevent damage to scan tool MB991958, always turn the ignition switch to the "LOCK" (OFF) position before connecting or disconnecting scan tool MB991958.

- (1) Disconnect ECM connector B-10.

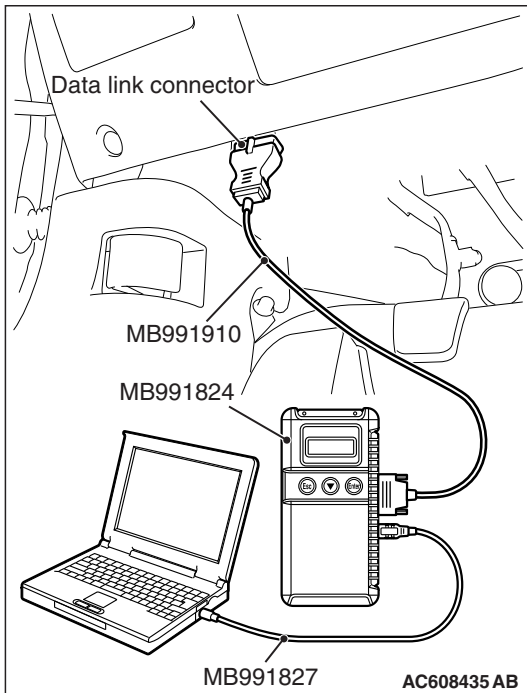

- (2) Connect scan tool MB991958 to the data link connector.
- (3) Turn the ignition switch to the "ON" position.

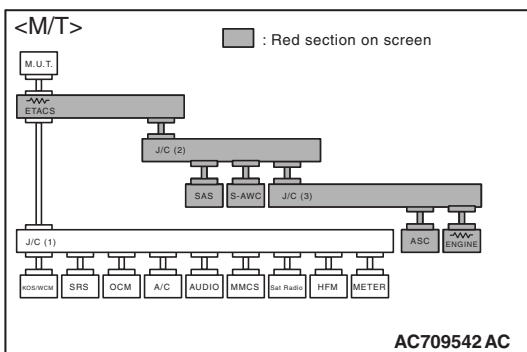

- (4) Diagnose CAN bus lines, and check if the scan tool MB991958 screen is as shown in the figure.

**OK:** The display of the scan tool MB991958 is as shown in the figure.

**Q:** Does scan tool MB991958 screen correspond to the illustration?

**YES :** Repair the wiring harness between ECM connector B-10 and joint connector (CAN3) C-127 <M/T>, or check intermediate connector A-13, and repair if necessary. If the intermediate connector is in good condition, repair the wiring harness between ECM connector B-10 and joint connector (CAN4) A-14 <TC-SST>.

**NO :** Check ECM connector B-10, and repair if necessary. If the ECM connector is in good condition, replace the ECM.

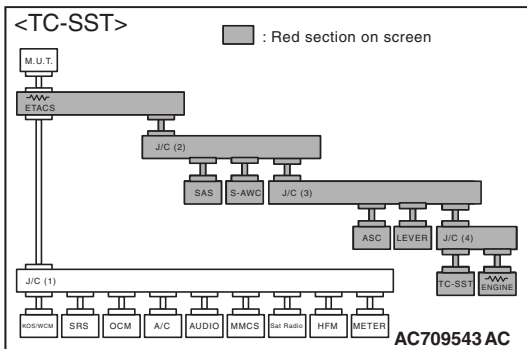

**STEP 16.** Using scan tool MB991958, diagnose the CAN bus line. (checking the shift lever for internal short)

**CAUTION**

Strictly observe the specified wiring harness repair procedure. For details refer to P.54C-7.

**CAUTION**

To prevent damage to scan tool MB991958, always turn the ignition switch to the "LOCK" (OFF) position before connecting or disconnecting scan tool MB991958.

- (1) Disconnect shift lever connector C-27.
- (2) Connect scan tool MB991958 to the data link connector.
- (3) Turn the ignition switch to the "ON" position.

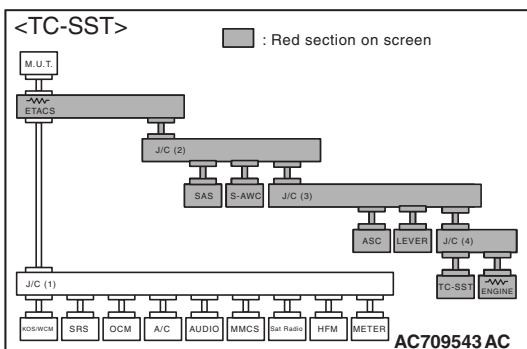
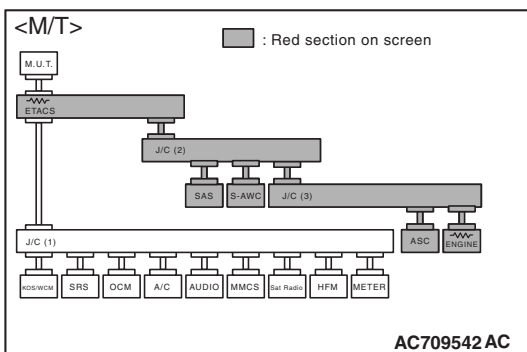
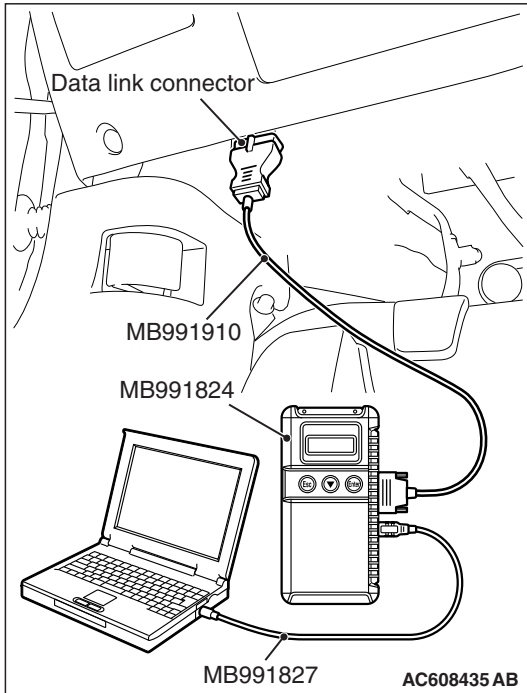

- (4) Diagnose CAN bus lines, and check if the scan tool MB991958 screen is as shown in the figure.

**OK:** The display of the scan tool MB991958 is as shown in the figure.

**Q:** Does scan tool MB991958 screen correspond to the illustration?

**YES :** Repair the wiring harness between shift lever connector C-27 and joint connector (CAN3) C-127.

**NO :** Check shift lever connector C-27, and repair if necessary. If the shift lever connector is in good condition, replace the shift lever.

**STEP 17. Using scan tool MB991958, diagnose the CAN bus line. (checking the TC-SST-ECU for internal short)**

**⚠ CAUTION**

Strictly observe the specified wiring harness repair procedure. For details refer to [P.54C-7](#).

**⚠ CAUTION**

To prevent damage to scan tool MB991958, always turn the ignition switch to the "LOCK" (OFF) position before connecting or disconnecting scan tool MB991958.

- (1) Disconnect transaxle assembly connector B-107.
- (2) Connect scan tool MB991958 to the data link connector.
- (3) Turn the ignition switch to the "ON" position.

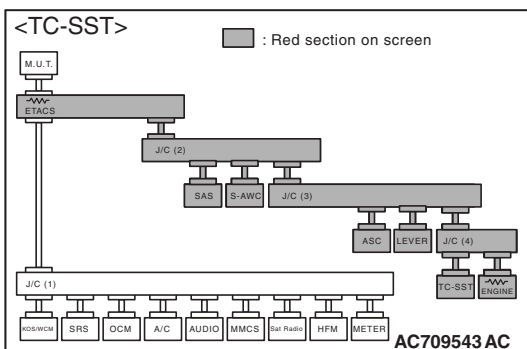
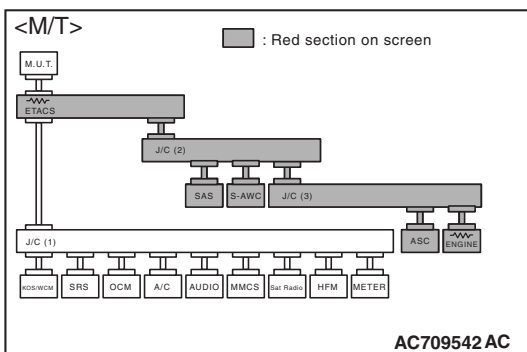
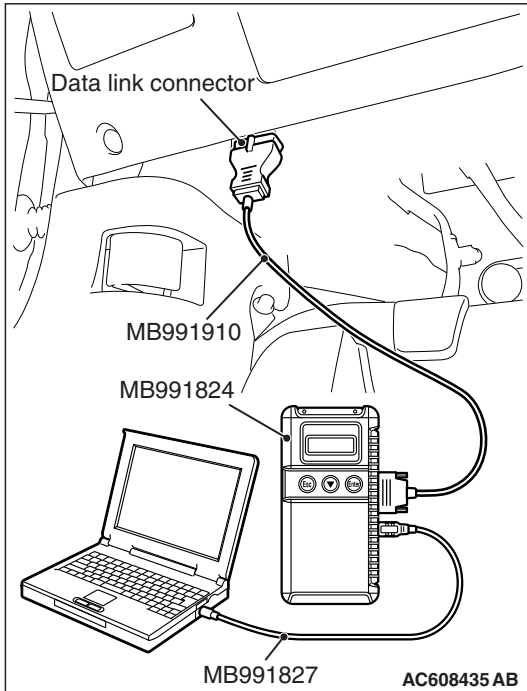

- (4) Diagnose CAN bus lines, and check if the scan tool MB991958 screen is as shown in the figure.

**OK:** The display of the scan tool MB991958 is as shown in the figure.

**Q:** Does scan tool MB991958 screen correspond to the illustration?

**YES :** Repair the wiring harness between transaxle assembly connector B-107 and joint connector (CAN4) A-14.

**NO :** Check transaxle assembly connector B-107, and repair if necessary. If the transaxle assembly connector is in good condition, replace the transaxle assembly

**STEP 18.** Using scan tool MB991958, diagnose the CAN bus line.

**⚠ CAUTION**

To prevent damage to scan tool MB991958, always turn the ignition switch to the "LOCK" (OFF) position before connecting or disconnecting scan tool MB991958.

- (1) Connect scan tool MB991958 to the data link connector.
- (2) Turn the ignition switch to the "ON" position.

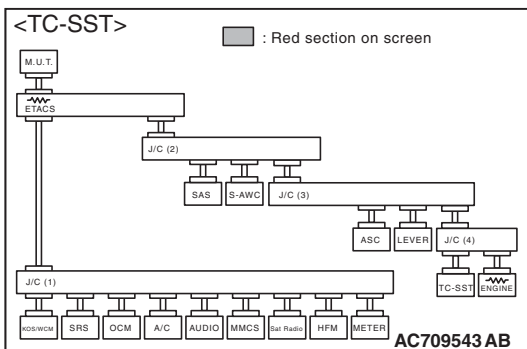
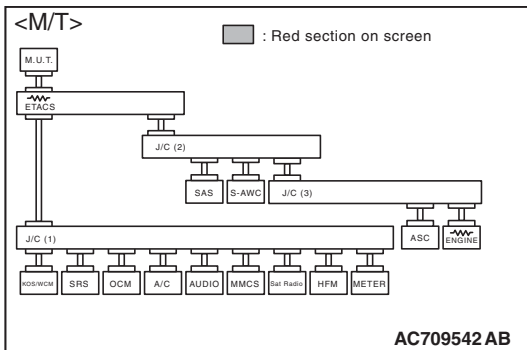
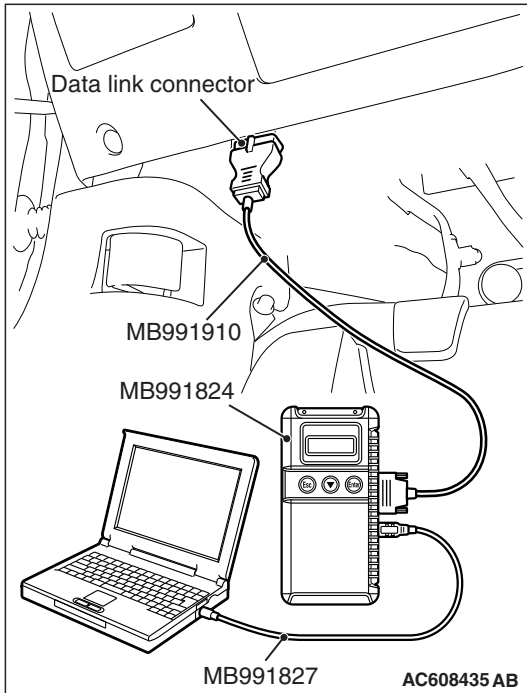

- (3) Diagnose CAN bus lines, and check if the scan tool screen is as shown in the illustration.

**Q: Does the scan tool screen correspond to the illustration?**

**YES :** The trouble can be an intermittent malfunction (Refer to GROUP 00, How to use

Troubleshooting/inspection Service Points –How to Cope with Intermittent Malfunction P.00-15).

**NO :** Check ETACS-ECU connector C-301, and repair if necessary. If the ETACS-ECU connector is in good condition, replace the ETACS-ECU.

DIAGNOSTIC ITEM 4: Diagnose shorts in the ground to CAN-C bus line.

CAN-C Communication Circuit <M/T>

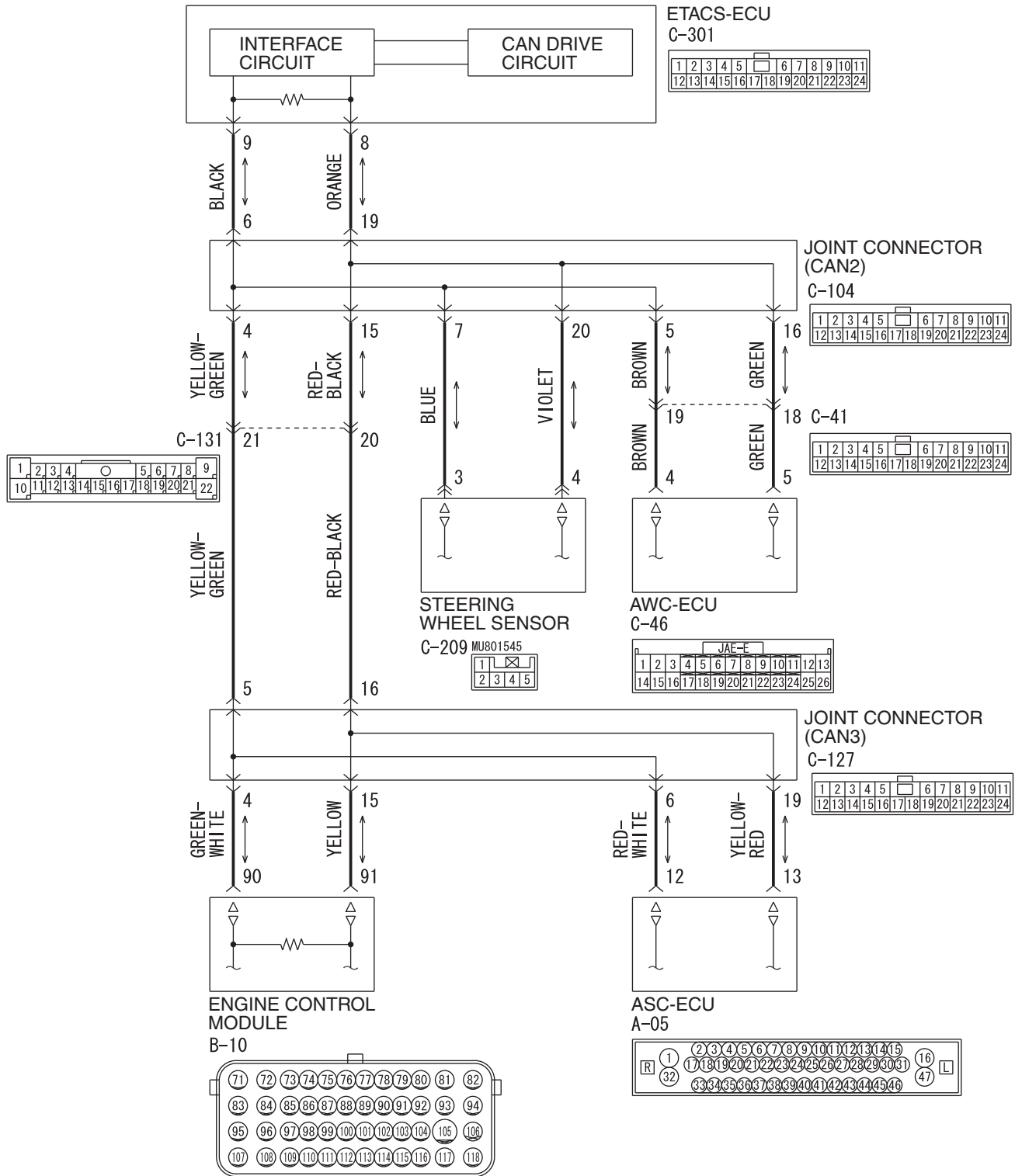

CAN-C Communication Circuit <TC-SST>

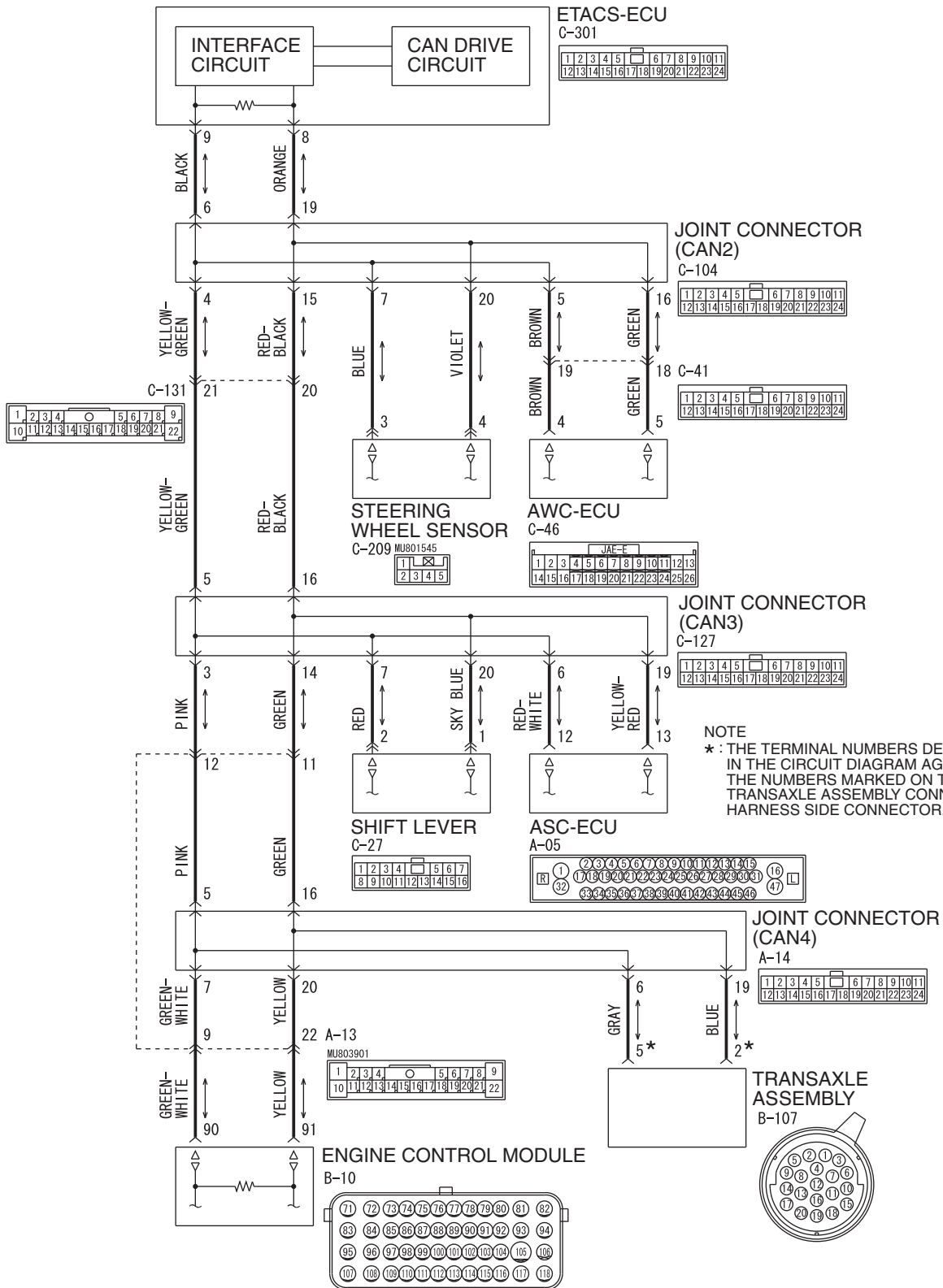

WAH54M052A



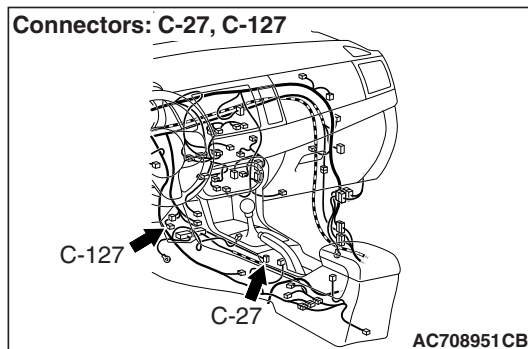
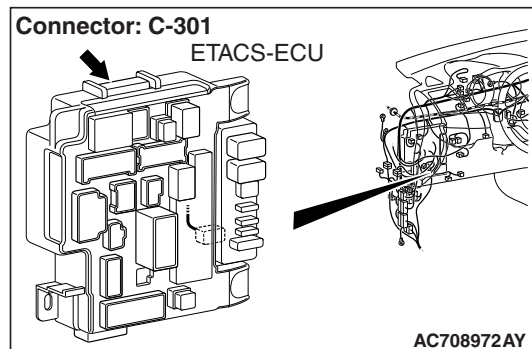
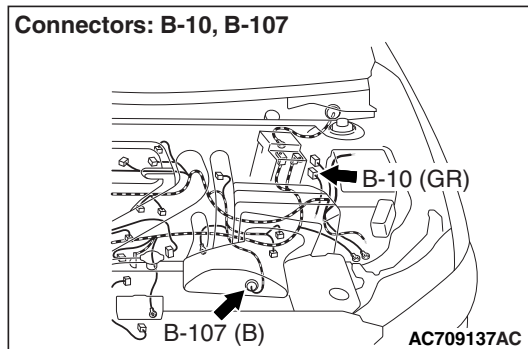
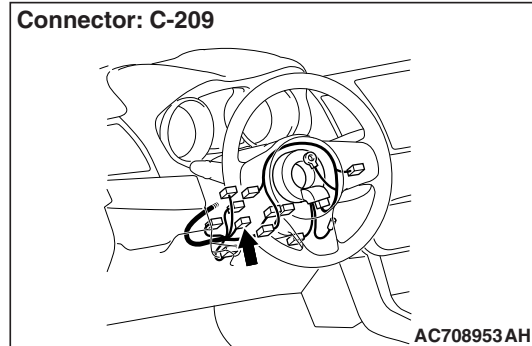
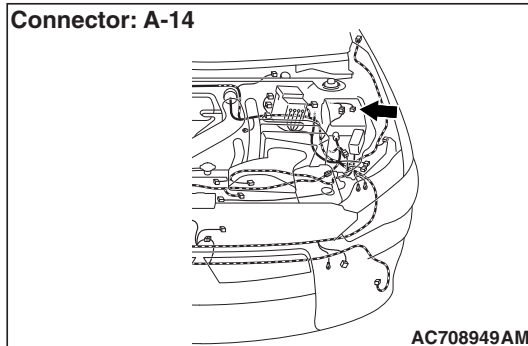
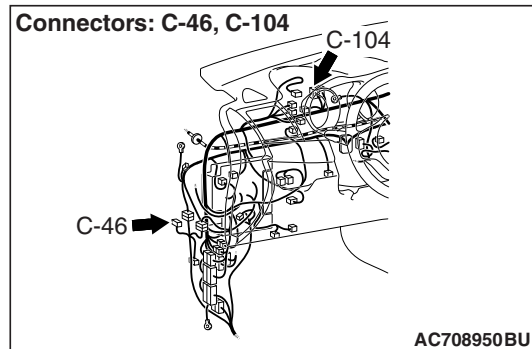
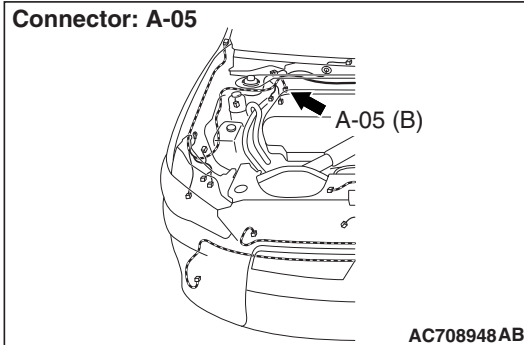

## FUNCTION

If a short to ground is present in the CAN-C lines, this diagnosis result will be set.

## TROUBLE JUDGMENT CONDITIONS

If DTC U1120 is set, the ETACS-ECU determines that there is a failure.

## TROUBLESHOOTING HINTS

- Malfunction of the connector (short to ground inside connector)
- Malfunction of the wiring harness (short to ground in the CAN-C main or sub bus lines)
- Malfunction of the ECU (ETACS-ECU, or ECUs on CAN-C lines failed)

## DIAGNOSIS

## Required Special Tools:

- MB991223: Harness Set
- MB992006: Extra Fine Probe
- MB991958: Scan Tool (M.U.T.-III Sub Assembly)
  - MB991824: Vehicle Communication Interface (V.C.I.)
  - MB991827: M.U.T.-III USB Cable
  - MB991910: M.U.T.-III Main Harness A
- MB992110: Power plant ECU check harness
- MB991997: ASC Check Harness

**STEP 1. Check the wiring harness between joint connector (CAN2) C-104 and steering wheel sensor connector C-209 for a short to ground. Measure the resistance at joint connector (CAN2) C-104.**

**⚠ CAUTION**

Disconnect the negative battery terminal. For details refer to [P.54C-7](#).

**⚠ CAUTION**

A digital multimeter should be used. For details refer to [P.54C-7](#).

**⚠ CAUTION**

The test wiring harness should be used. For details refer to [P.54C-7](#).

- (1) Disconnect joint connector (CAN2), and measure the resistance at the wiring harness side of joint connector (CAN2).
- (2) Measure the resistance between joint connector (CAN2) terminal 7 and body ground.

**OK: 1 k $\Omega$  or more**

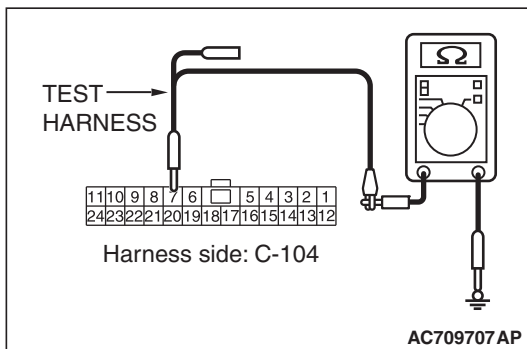

- (3) Measure the resistance between joint connector (CAN2) terminal 20 and body ground.

**OK: 1 k $\Omega$  or more**

**Q: Do all the resistances measure 1 k $\Omega$  or more?**

**YES :** Go to Step 2.

**NO :** Go to Step 10.

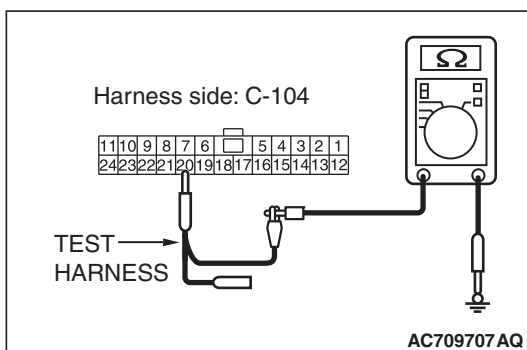

**STEP 2.** Check the wiring harness between joint connector (CAN2) C-104 and AWC-ECU connector C-46 for a short to ground. Measure the resistance at joint connector (CAN2) C-104.

**⚠ CAUTION**

Disconnect the negative battery terminal. For details refer to P.54C-7.

**⚠ CAUTION**

A digital multimeter should be used. For details refer to P.54C-7.

**⚠ CAUTION**

The test wiring harness should be used. For details refer to P.54C-7.

- (1) Disconnect joint connector (CAN2), and measure the resistance at the wiring harness side of joint connector (CAN2).
- (2) Measure the resistance between joint connector (CAN2) terminal 5 and body ground.

**OK: 1 k $\Omega$  or more**

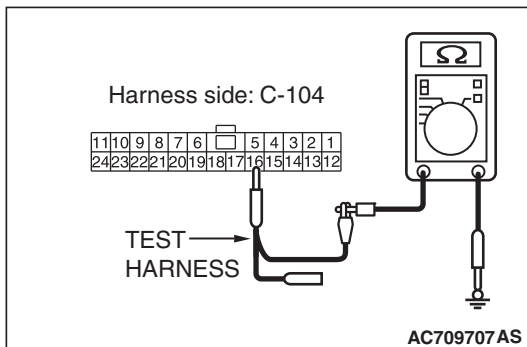
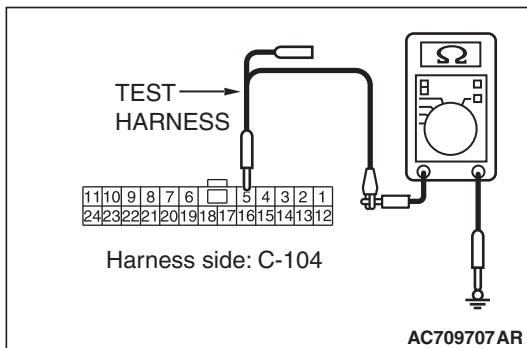

- (3) Measure the resistance between joint connector (CAN2) terminal 16 and body ground.

**OK: 1 k $\Omega$  or more**

**Q: Do all the resistances measure 1 k $\Omega$  or more?**

**YES :** Go to Step 3.

**NO :** Go to Step 11.

**STEP 3.** Check the wiring harness between joint connector (CAN2) C-104 and ETACS-ECU connector C-301 for a short to ground. Measure the resistance at joint connector (CAN2) C-104.

**⚠ CAUTION**

Disconnect the negative battery terminal. For details refer to P.54C-7.

**⚠ CAUTION**

A digital multimeter should be used. For details refer to P.54C-7.

**⚠ CAUTION**

The test wiring harness should be used. For details refer to P.54C-7.

- (1) Disconnect joint connector (CAN2), and measure the resistance at the wiring harness side of joint connector (CAN2).
- (2) Measure the resistance between joint connector (CAN2) terminal 6 and body ground.

**OK: 1 k $\Omega$  or more**

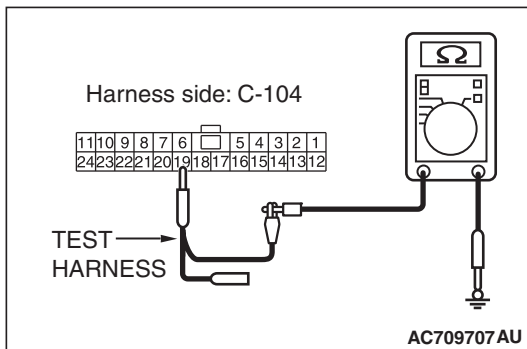
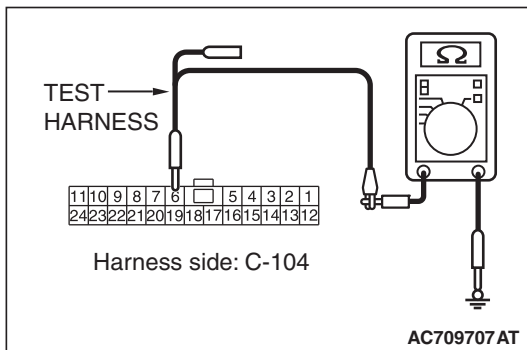

- (3) Measure the resistance between joint connector (CAN2) terminal 19 and body ground.

**OK: 1 k $\Omega$  or more**

**Q: Do all the resistances measure 1 k $\Omega$  or more?**

**YES :** Go to Step 4.

**NO :** Go to Step 12.

**STEP 4.** Check the wiring harness between joint connector (CAN3) C-127 and ASC-ECU connector A-05 for a short to ground. Measure the resistance at joint connector (CAN3) C-127.

**⚠ CAUTION**

Disconnect the negative battery terminal. For details refer to P.54C-7.

**⚠ CAUTION**

A digital multimeter should be used. For details refer to P.54C-7.

**⚠ CAUTION**

The test wiring harness should be used. For details refer to P.54C-7.

- (1) Disconnect joint connector (CAN3), and measure the resistance at the wiring harness side of joint connector (CAN3).
- (2) Measure the resistance between joint connector (CAN3) terminal 6 and body ground.

**OK: 1 kΩ or more**

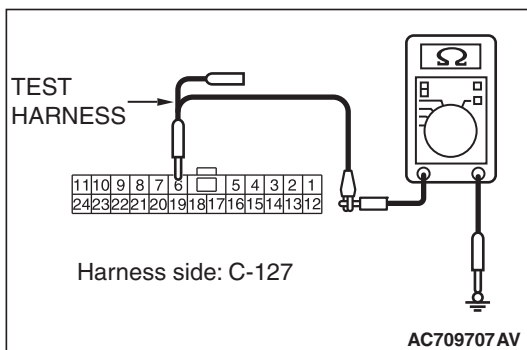

- (3) Measure the resistance between joint connector (CAN3) terminal 19 and body ground.

**OK: 1 kΩ or more**

**Q: Do all the resistances measure 1 kΩ or more?**

**YES <M/T>** : Go to Step 5.

**YES <TC-SST>** : Go to Step 6.

**NO** : Go to Step 13.

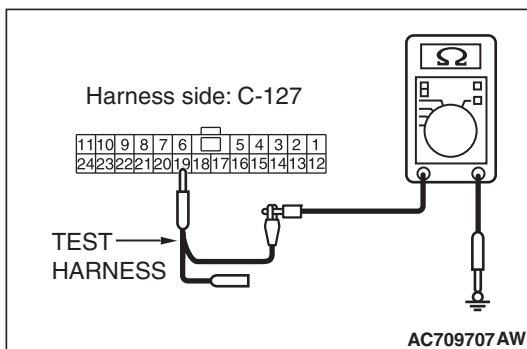

**STEP 5.** Check the wiring harness between joint connector (CAN3) C-127 and ECM connector B-10 <M/T> for a short to ground. Measure the resistance at joint connector (CAN3) C-127.

**⚠ CAUTION**

Disconnect the negative battery terminal. For details refer to P.54C-7.

**⚠ CAUTION**

A digital multimeter should be used. For details refer to P.54C-7.

**⚠ CAUTION**

The test wiring harness should be used. For details refer to P.54C-7.

- (1) Disconnect joint connector (CAN3), and measure the resistance at the wiring harness side of joint connector (CAN3).
- (2) Measure the resistance between joint connector (CAN3) terminal 4 and body ground.

**OK: 1 k $\Omega$  or more**

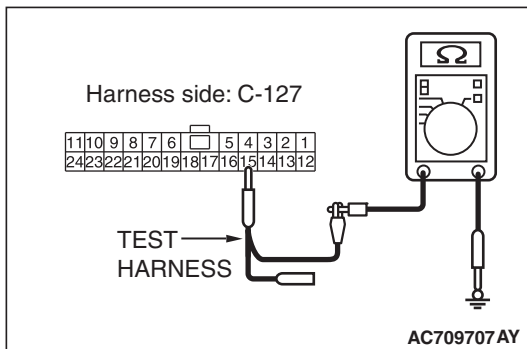
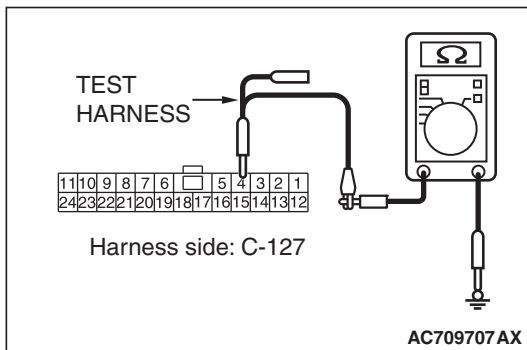

- (3) Measure the resistance between joint connector (CAN3) terminal 15 and body ground.

**OK: 1 k $\Omega$  or more**

**Q: Do all the resistances measure 1 k $\Omega$  or more?**

**YES :** Check intermediate connector C-131, and repair if necessary. If the intermediate connector is in good condition, repair the wiring harness between joint connector (CAN2) C-104 and joint connector (CAN3) C-127.

**NO :** Go to Step 14.

**STEP 6.** Check the wiring harness between joint connector (CAN3) C-127 and shift lever connector C-27 <TC-SST> for a short to ground. Measure the resistance at joint connector (CAN3) C-127.

**⚠ CAUTION**

Disconnect the negative battery terminal. For details refer to P.54C-7.

**⚠ CAUTION**

A digital multimeter should be used. For details refer to P.54C-7.

**⚠ CAUTION**

The test wiring harness should be used. For details refer to P.54C-7.

- (1) Disconnect joint connector (CAN3), and measure the resistance at the wiring harness side of joint connector (CAN3).
- (2) Measure the resistance between joint connector (CAN3) terminal 7 and body ground.

**OK: 1 kΩ or more**

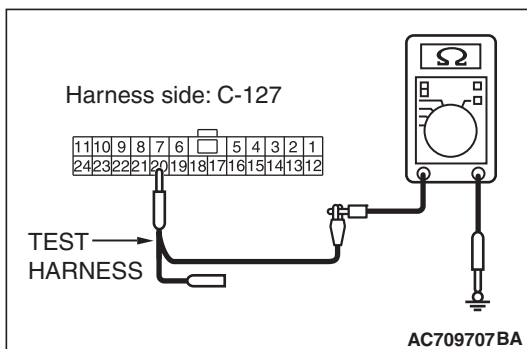
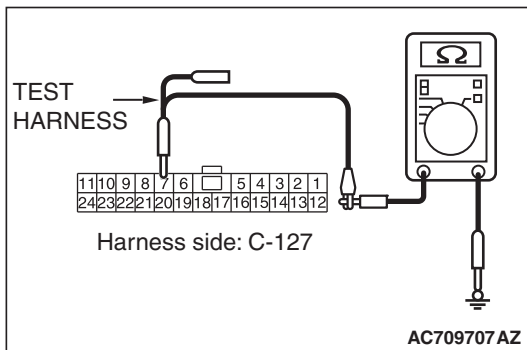

- (3) Measure the resistance between joint connector (CAN3) terminal 20 and body ground.

**OK: 1 kΩ or more**

**Q: Do all the resistances measure 1 kΩ or more?**

**YES :** Go to Step 7.

**NO :** Go to Step 15.

**STEP 7.** Check the wiring harness between joint connector (CAN4) A-14 and ECM connector B-10 <TC-SST> for a short to ground. Measure the resistance at joint connector (CAN4) A-14.

**CAUTION**

Disconnect the negative battery terminal. For details refer to P.54C-7.

**CAUTION**

A digital multimeter should be used. For details refer to P.54C-7.

**CAUTION**

The test wiring harness should be used. For details refer to P.54C-7.

- (1) Disconnect joint connector (CAN4), and measure the resistance at the wiring harness side of joint connector (CAN4).
- (2) Measure the resistance between joint connector (CAN4) terminal 7 and body ground.

**OK: 1 k $\Omega$  or more**

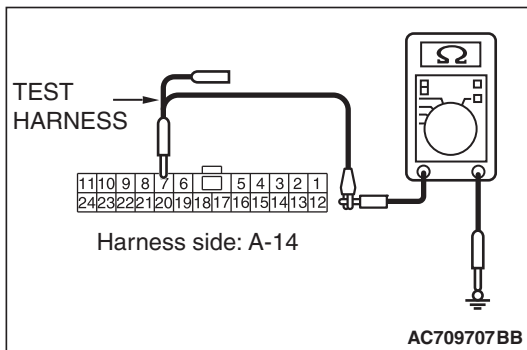

- (3) Measure the resistance between joint connector (CAN4) terminal 20 and body ground.

**OK: 1 k $\Omega$  or more**

**Q: Do all the resistances measure 1 k $\Omega$  or more?**

**YES :** Go to Step 8.

**NO :** Go to Step 14.

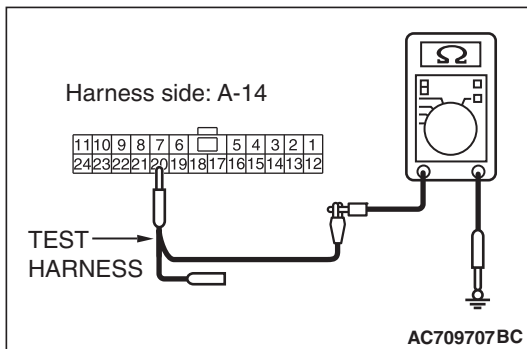



**STEP 8.** Check the wiring harness between joint connector (CAN4) A-14 and transaxle assembly connector B-107 <TC-SST> for a short to ground. Measure the resistance at joint connector (CAN4) A-14.

**⚠ CAUTION**

Disconnect the negative battery terminal. For details refer to P.54C-7.

**⚠ CAUTION**

A digital multimeter should be used. For details refer to P.54C-7.

**⚠ CAUTION**

The test wiring harness should be used. For details refer to P.54C-7.

- (1) Disconnect joint connector (CAN4), and measure the resistance at the wiring harness side of joint connector (CAN4).
- (2) Measure the resistance between joint connector (CAN4) terminal 6 and body ground.

**OK: 1 kΩ or more**

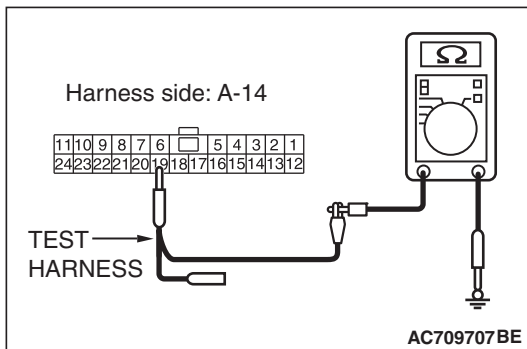
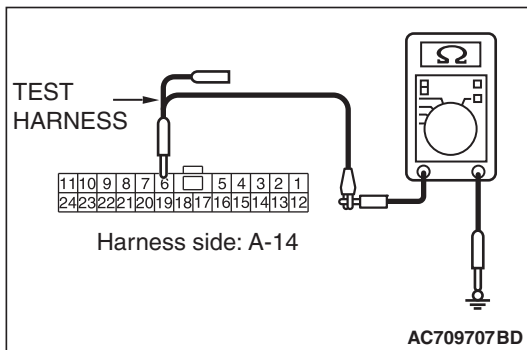

- (3) Measure the resistance between joint connector (CAN4) terminal 19 and body ground.

**OK: 1 kΩ or more**

**Q: Do all the resistances measure 1 kΩ or more?**

**YES :** Go to Step 9.

**NO :** Go to Step 16.

**STEP 9.** Check the wiring harness between joint connector (CAN3) C-127 and joint connector (CAN2) C-104 for a short to ground. Measure the resistance at joint connector (CAN3) C-127.

**⚠ CAUTION**

Disconnect the negative battery terminal. For details refer to P.54C-7.

**⚠ CAUTION**

A digital multimeter should be used. For details refer to P.54C-7.

**⚠ CAUTION**

The test wiring harness should be used. For details refer to P.54C-7.

- (1) Disconnect joint connector (CAN3), and measure the resistance at the wiring harness side of joint connector (CAN3).
- (2) Measure the resistance between joint connector (CAN3) terminal 5 and body ground.

**OK: 1 kΩ or more**

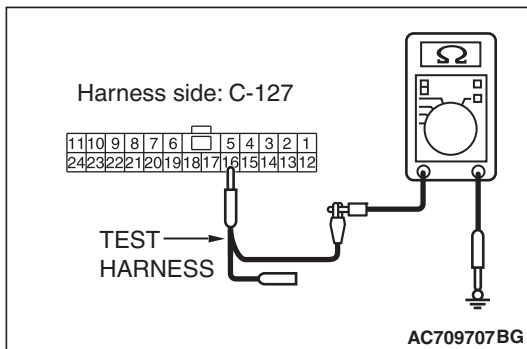
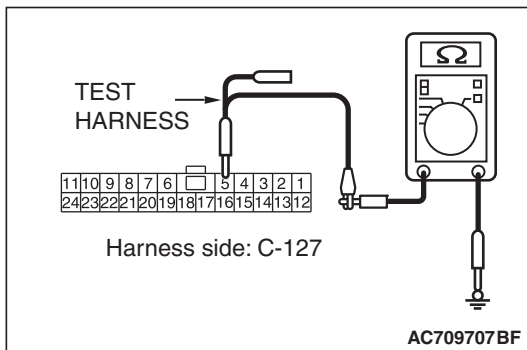

- (3) Measure the resistance between joint connector (CAN3) terminal 16 and body ground.

**OK: 1 kΩ or more**

**Q: Do all the resistances measure 1 kΩ or more?**

**YES :** Check intermediate connector A-13, and repair if necessary. If the intermediate connector is in good condition, repair the wiring harness between joint connector (CAN3) C-127 and joint connector (CAN4) A-14.

**NO :** Check intermediate connector C-131, and repair if necessary. If the intermediate connector is in good condition, repair the wiring harness between joint connector (CAN3) C-127 and joint connector (CAN2) C-104.

**STEP 10.** Using scan tool MB991958, diagnose the CAN bus line. (checking the steering wheel sensor for internal short to ground)

**⚠ CAUTION**

Strictly observe the specified wiring harness repair procedure. For details refer to [P.54C-7](#).

**⚠ CAUTION**

To prevent damage to scan tool MB991958, always turn the ignition switch to the "LOCK" (OFF) position before connecting or disconnecting scan tool MB991958.

- (1) Disconnect steering wheel sensor connector C-209.
- (2) Connect scan tool MB991958 to the data link connector.
- (3) Turn the ignition switch to the "ON" position.

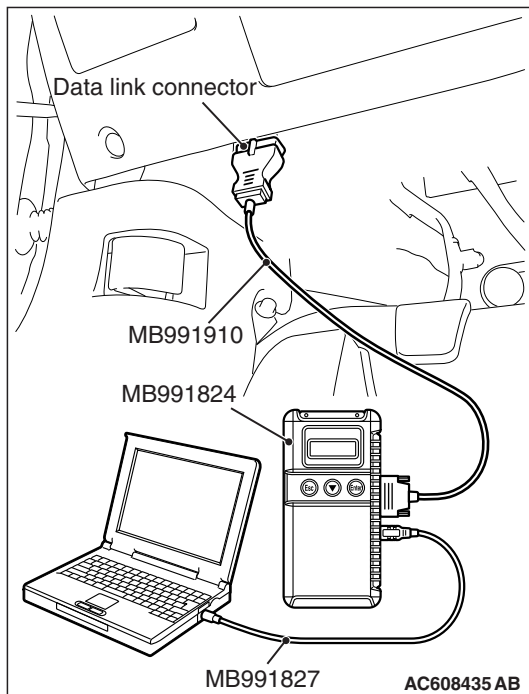

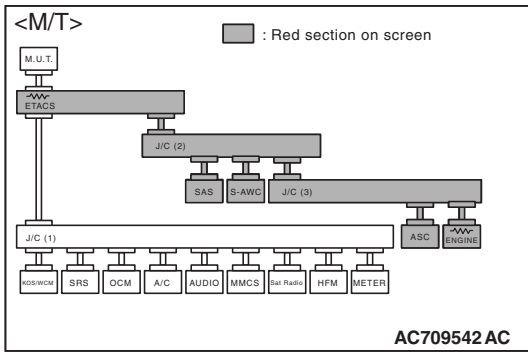

(4) Diagnose CAN bus lines, and check if the scan tool MB991958 screen is as shown in the figure.

**OK:** The display of the scan tool MB991958 is as shown in the figure.

**Q:** Does scan tool MB991958 screen correspond to the illustration?

**YES :** Repair the wiring harness between steering wheel sensor connector C-209 and joint connector (CAN2) C-104.

**NO :** Check steering wheel sensor connector C-209, and repair if necessary. If the steering wheel sensor connector is in good condition, replace the steering wheel sensor.

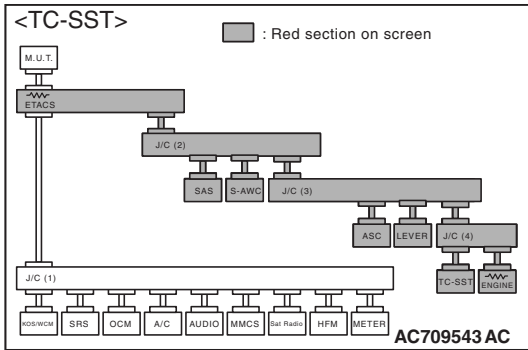

**STEP 11. Using scan tool MB991958, diagnose the CAN bus line. (checking the AWC-ECU for internal short to ground)**

**⚠ CAUTION**

Strictly observe the specified wiring harness repair procedure. For details refer to [P.54C-7](#).

**⚠ CAUTION**

To prevent damage to scan tool MB991958, always turn the ignition switch to the "LOCK" (OFF) position before connecting or disconnecting scan tool MB991958.

- (1) Disconnect AWC-ECU connector C-46.
- (2) Connect scan tool MB991958 to the data link connector.
- (3) Turn the ignition switch to the "ON" position.

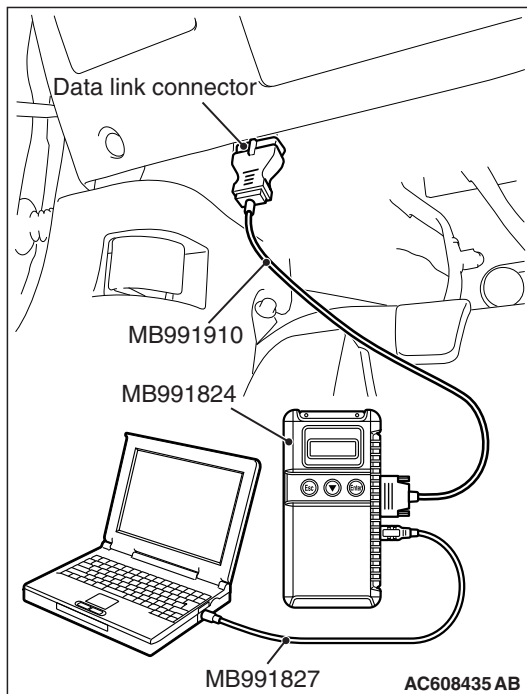

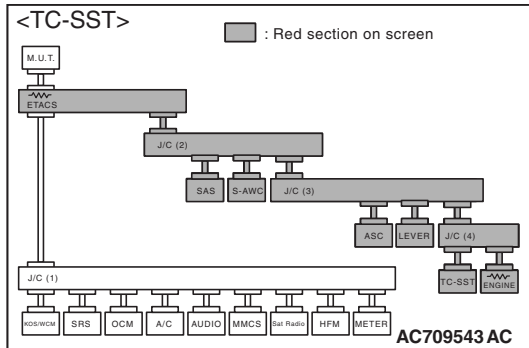
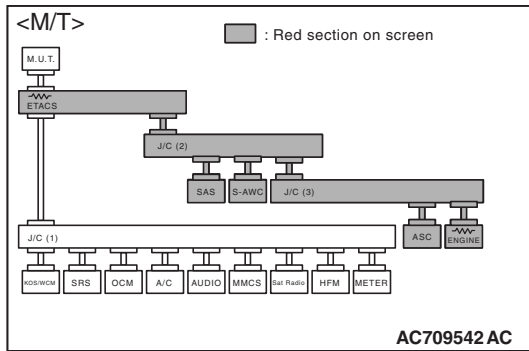

(4) Diagnose CAN bus lines, and check if the scan tool MB991958 screen is as shown in the figure.

**OK:** The display of the scan tool MB991958 is as shown in the figure.

**Q:** Does scan tool MB991958 screen correspond to the illustration?

**YES :** Repair the wiring harness between AWC-ECU connector C-46 and joint connector (CAN2) C-104.

**NO :** Check AWC-ECU connector C-46, and repair if necessary. If the AWC-ECU connector is in good condition, replace the AWC-ECU.

**STEP 12.** Check the wiring harness between joint connector (CAN2) C-104 and ETACS-ECU connector C-301 for a short to ground.

**CAUTION**

Disconnect the negative battery terminal. For details refer to P.54C-7.

**CAUTION**

A digital multimeter should be used. For details refer to P.54C-7.

**CAUTION**

The test wiring harness should be used. For details refer to P.54C-7.

**CAUTION**

Strictly observe the specified wiring harness repair procedure. For details refer to P.54C-7.

- (1) Disconnect ETACS-ECU connector and joint connector (CAN2), and measure at the wiring harness side.
- (2) Measure the resistance between joint connector (CAN2) terminal 6 and body ground.

**OK:** 1 kΩ or more

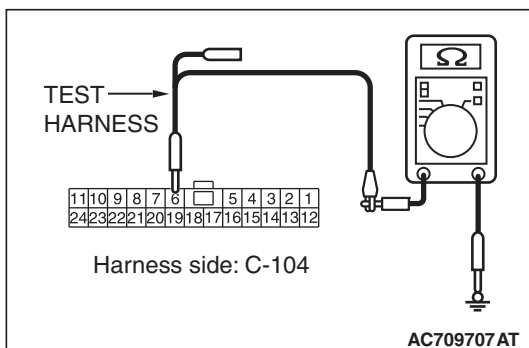

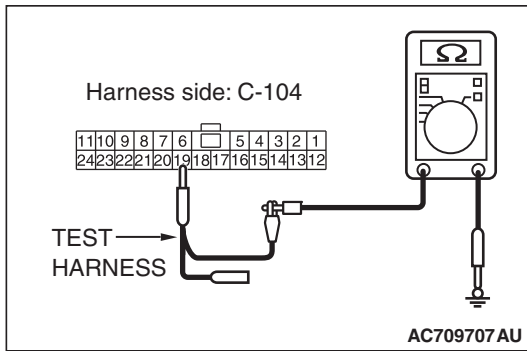

(3) Measure the resistance between joint connector (CAN2) terminal 19 and body ground.

**OK: 1 kΩ or more**

**Q: Do all the resistances measure 1 kΩ or more?**

**YES :** Check ETACS-ECU connector C-301, and repair if necessary. If the ETACS-ECU connector is in good condition, replace the ETACS-ECU.

**NO :** Repair the wiring harness between ETACS-ECU connector C-301 and joint connector (CAN2) C-104.

**STEP 13. Using scan tool MB991958, diagnose the CAN bus line. (checking the ASC-ECU for internal short to ground)**

**CAUTION**

Strictly observe the specified wiring harness repair procedure. For details refer to [P.54C-7](#).

**CAUTION**

To prevent damage to scan tool MB991958, always turn the ignition switch to the "LOCK" (OFF) position before connecting or disconnecting scan tool MB991958.

- (1) Disconnect ASC-ECU connector A-05.
- (2) Connect scan tool MB991958 to the data link connector.
- (3) Turn the ignition switch to the "ON" position.

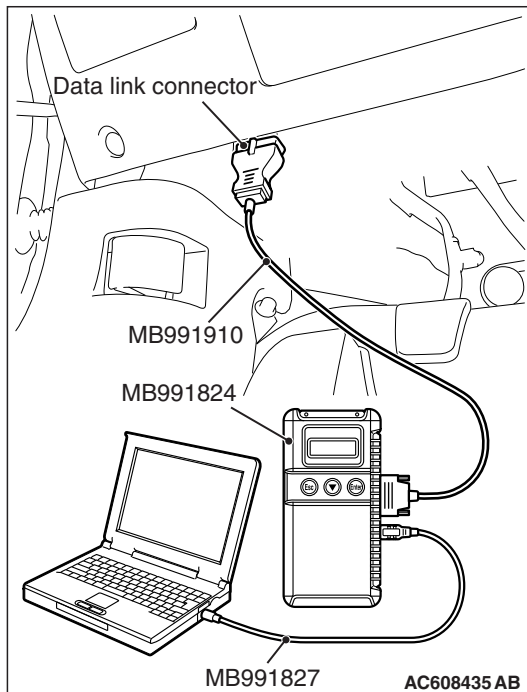

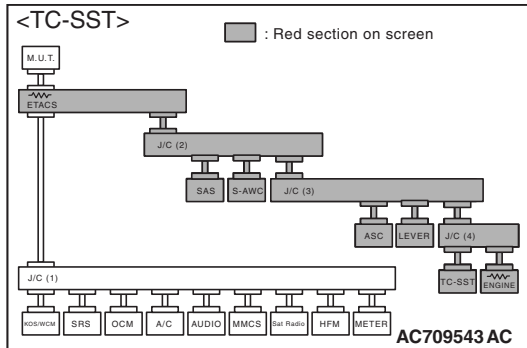
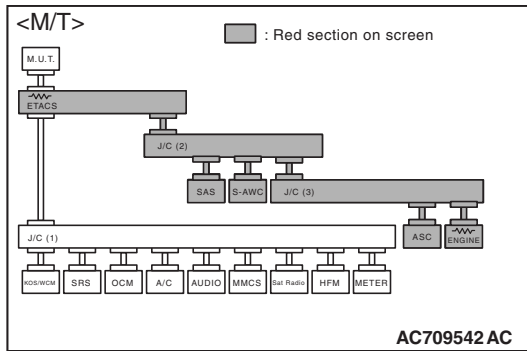

- (4) Diagnose CAN bus lines, and check if the scan tool MB991958 screen is as shown in the figure.

**OK:** The display of the scan tool MB991958 is as shown in the figure.

- Q:** Does scan tool MB991958 screen correspond to the illustration?

**YES :** Repair the wiring harness between ASC-ECU connector A-05 and joint connector (CAN3) C-127.

**NO :** Check ASC-ECU connector A-05, and repair if necessary. If the ASC-ECU connector is in good condition, replace the ASC-ECU.

**STEP 14.** Using scan tool MB991958, diagnose the CAN bus line. (checking the ECM for internal short to ground)

**⚠ CAUTION**

Strictly observe the specified wiring harness repair procedure. For details refer to [P.54C-7](#).

**⚠ CAUTION**

To prevent damage to scan tool MB991958, always turn the ignition switch to the "LOCK" (OFF) position before connecting or disconnecting scan tool MB991958.

- (1) Disconnect ECM connector B-10.



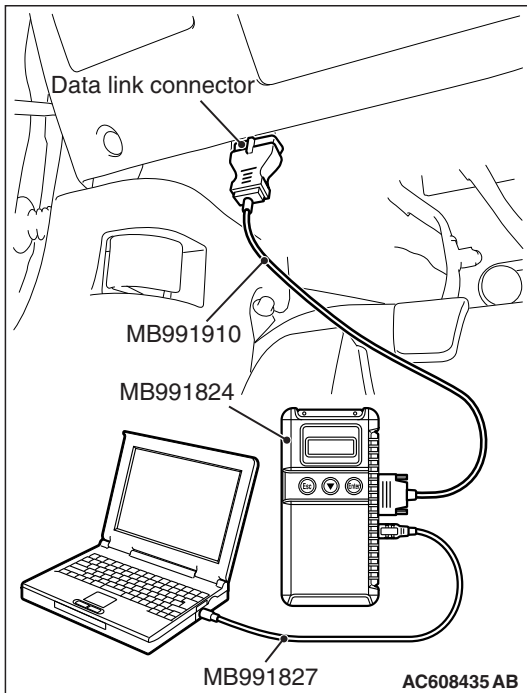

- (2) Connect scan tool MB991958 to the data link connector.
- (3) Turn the ignition switch to the "ON" position.

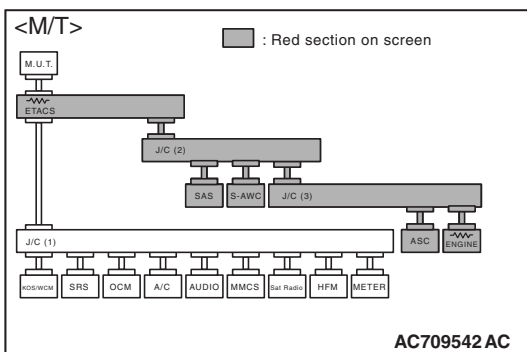

- (4) Diagnose CAN bus lines, and check if the scan tool MB991958 screen is as shown in the figure.

**OK:** The display of the scan tool MB991958 is as shown in the figure.

**Q:** Does scan tool MB991958 screen correspond to the illustration?

**YES :** Repair the wiring harness between ECM connector B-10 and joint connector (CAN3) C-127 <M/T>, or check intermediate connector A-13, and repair if necessary. If the intermediate connector is in good condition, repair the wiring harness between ECM connector B-10 and joint connector (CAN4) A-14 <TC-SST>.

**NO :** Check ECM connector B-10, and repair if necessary. If the ECM connector is in good condition, replace the ECM.

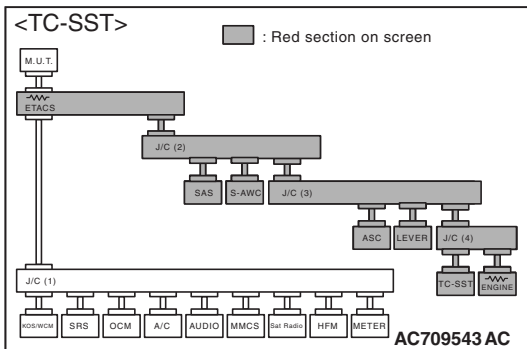

**STEP 15.** Using scan tool MB991958, diagnose the CAN bus line. (checking the shift lever for internal short to ground)

**⚠ CAUTION**

Strictly observe the specified wiring harness repair procedure. For details refer to [P.54C-7](#).

**⚠ CAUTION**

To prevent damage to scan tool MB991958, always turn the ignition switch to the "LOCK" (OFF) position before connecting or disconnecting scan tool MB991958.

- (1) Disconnect shift lever connector C-27.
- (2) Connect scan tool MB991958 to the data link connector.
- (3) Turn the ignition switch to the "ON" position.

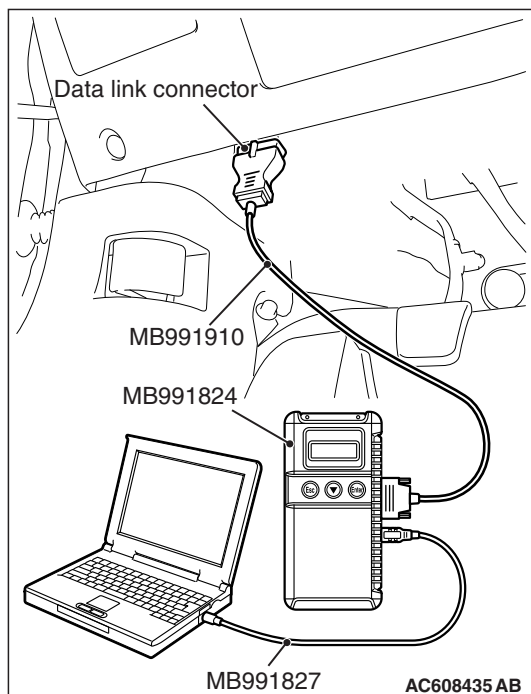

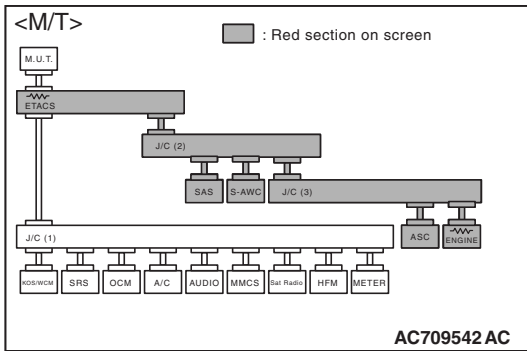

(4) Diagnose CAN bus lines, and check if the scan tool MB991958 screen is as shown in the figure.

**OK:** The display of the scan tool MB991958 is as shown in the figure.

**Q:** Does scan tool MB991958 screen correspond to the illustration?

**YES :** Repair the wiring harness between shift lever connector C-27 and joint connector (CAN3) C-127.

**NO :** Check shift lever connector C-27, and repair if necessary. If the shift lever connector is in good condition, replace the shift lever.

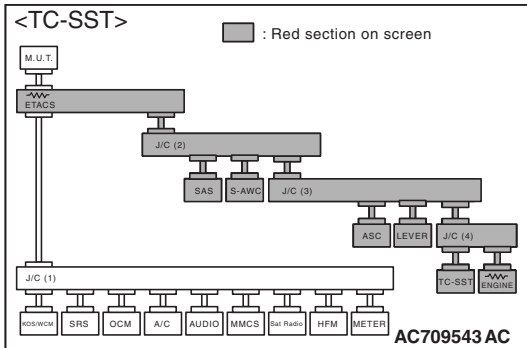

**STEP 16.** Using scan tool MB991958, diagnose the CAN bus line. (checking the TC-SST-ECU for internal short to ground)

**CAUTION**

Strictly observe the specified wiring harness repair procedure. For details refer to [P.54C-7](#).

**CAUTION**

To prevent damage to scan tool MB991958, always turn the ignition switch to the "LOCK" (OFF) position before connecting or disconnecting scan tool MB991958.

(1) Disconnect transaxle assembly connector B-107.

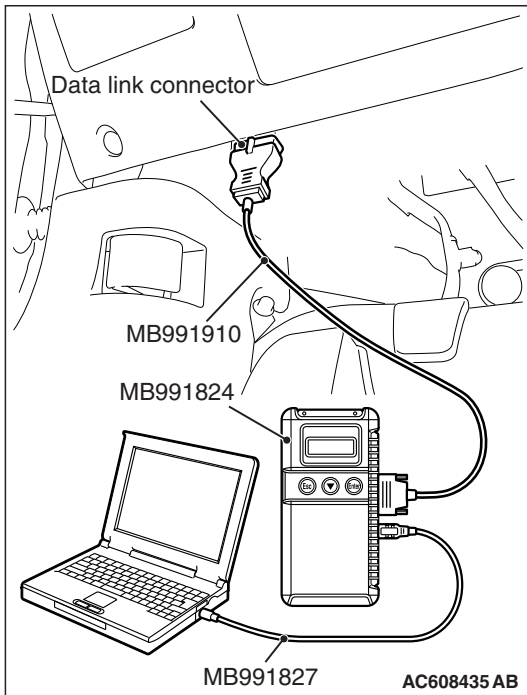

- (2) Connect scan tool MB991958 to the data link connector.
- (3) Turn the ignition switch to the "ON" position.

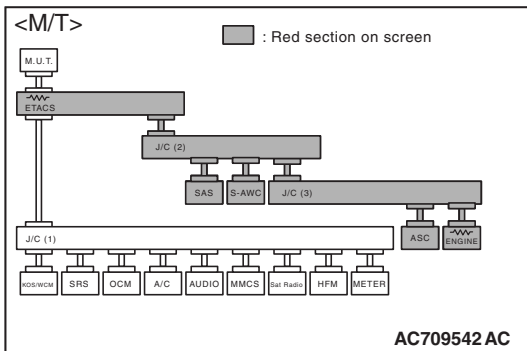

- (4) Diagnose CAN bus lines, and check if the scan tool MB991958 screen is as shown in the figure.

**OK:** The display of the scan tool MB991958 is as shown in the figure.

**Q:** Does scan tool MB991958 screen correspond to the illustration?

**YES :** Repair the wiring harness between transaxle assembly connector B-107 and joint connector (CAN4) A-14.

**NO :** Check transaxle assembly connector B-107, and repair if necessary. If the transaxle assembly connector is in good condition, replace the transaxle assembly.

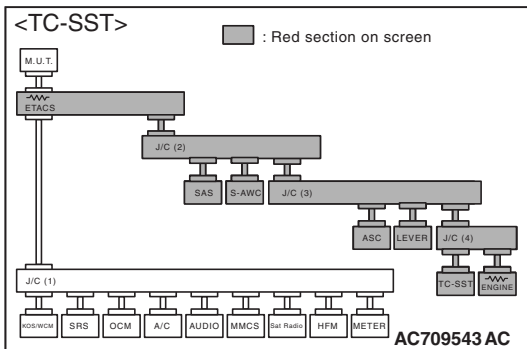

DIAGNOSTIC ITEM 5: Diagnose shorts in the power supply to CAN-C bus line.

CAN-C Communication Circuit <M/T>

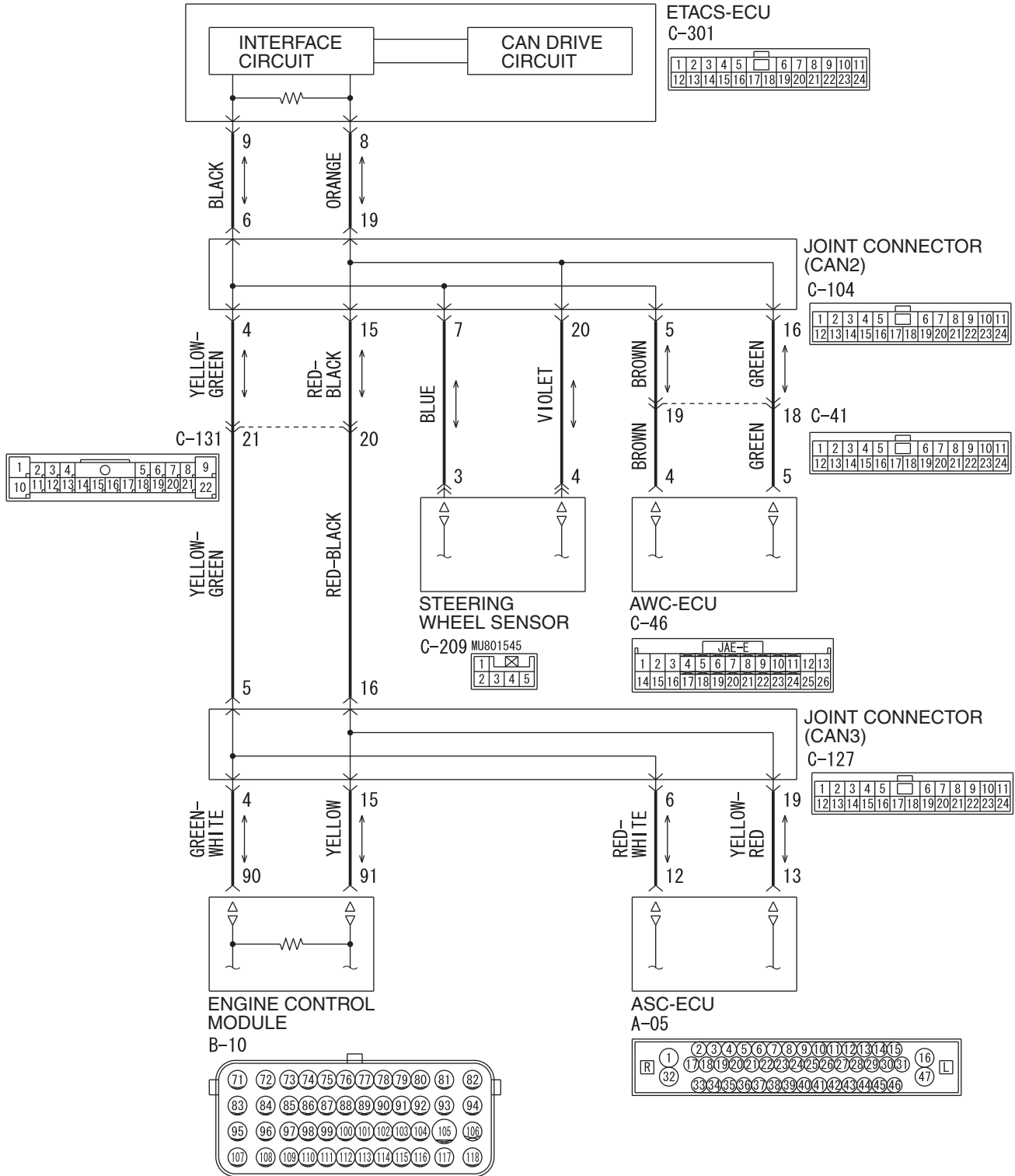

CAN-C Communication Circuit <TC-SST>

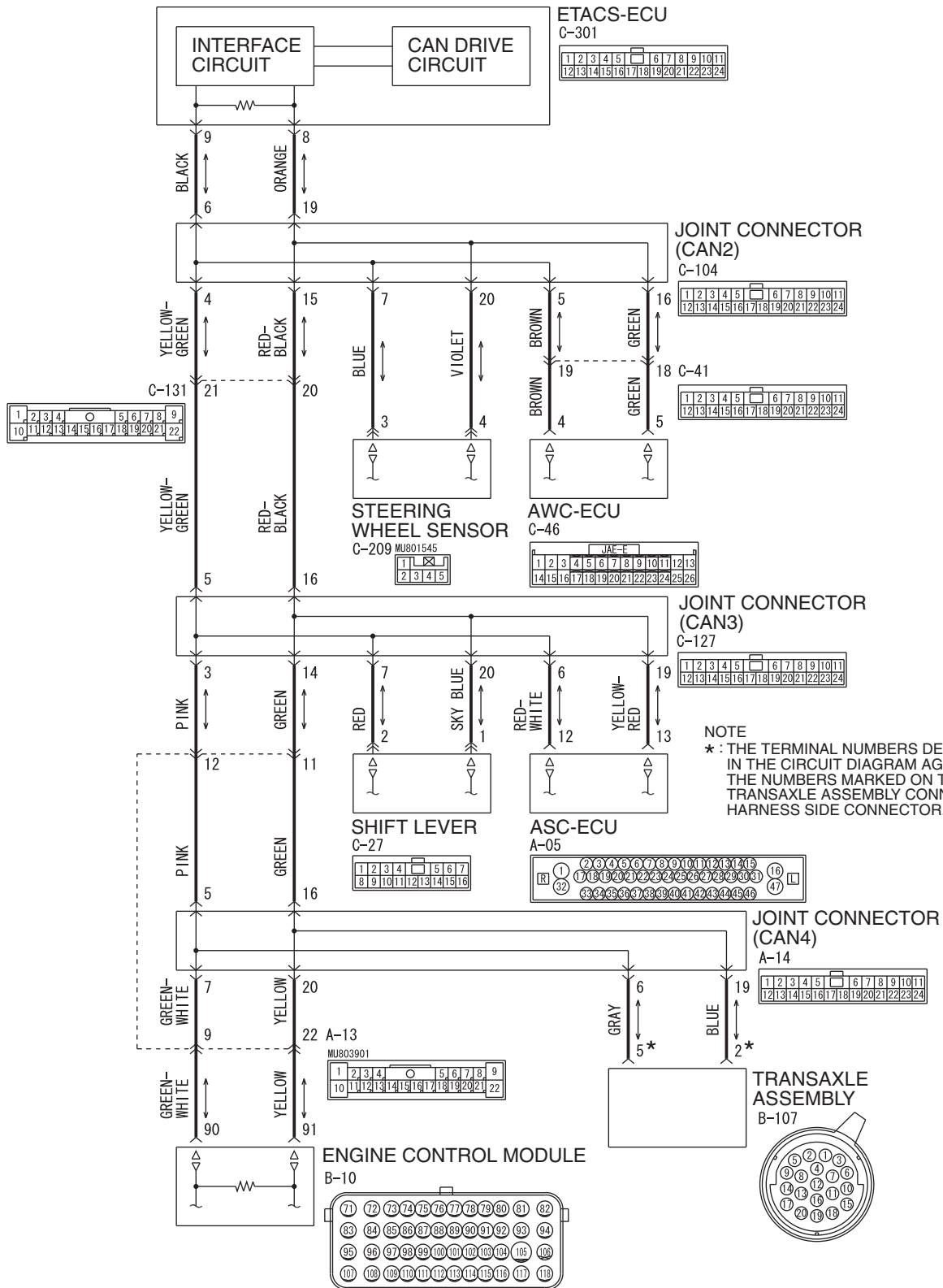

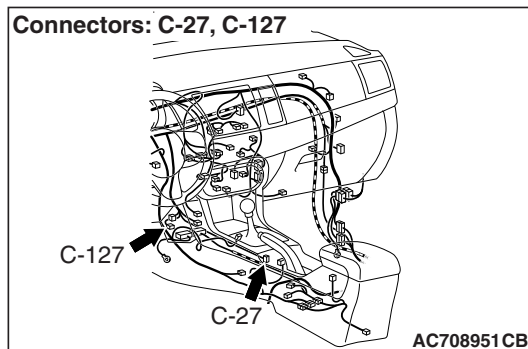
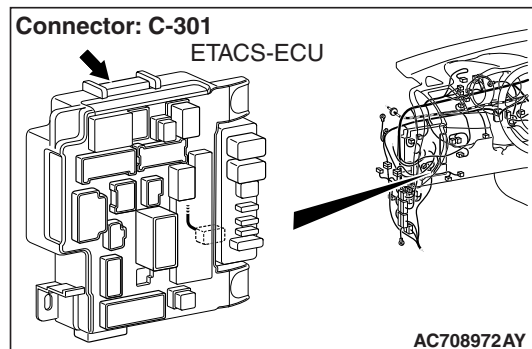
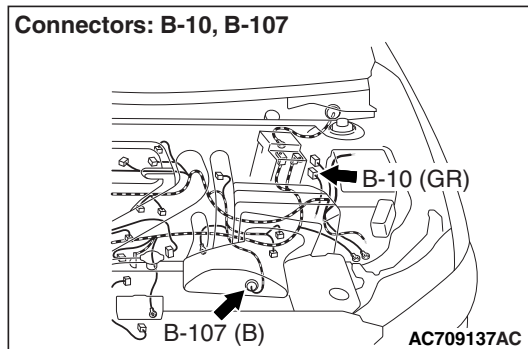
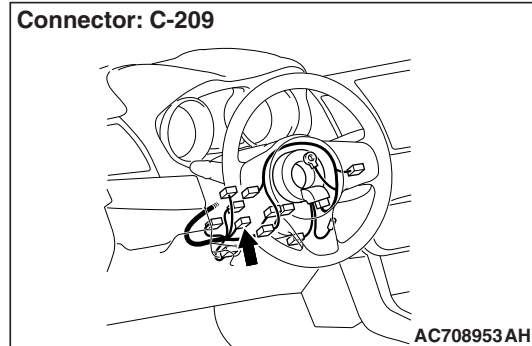
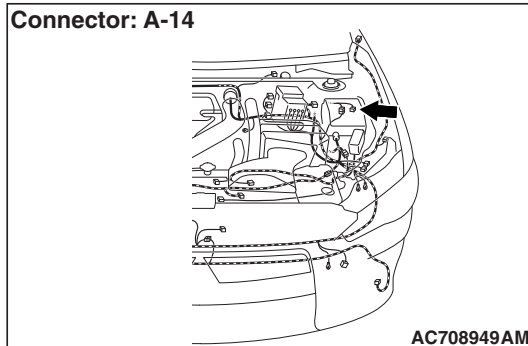
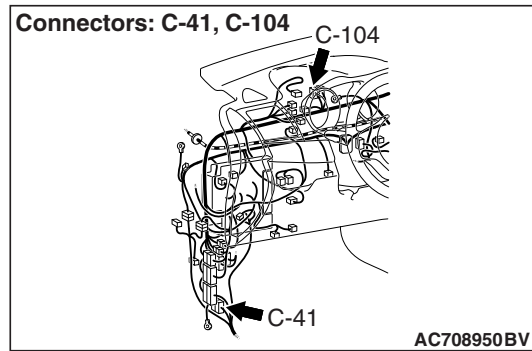
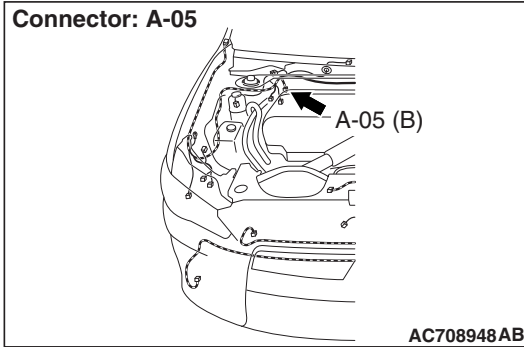

## FUNCTION

If a short to power supply is present in the CAN-C lines, this diagnosis result will be set.

## TROUBLE JUDGMENT CONDITIONS

The wiring harness wire or connectors may have loose, corroded, or damaged terminals, or terminals pushed back in the connector, or an ECU may be defective.

## TROUBLESHOOTING HINTS

- Malfunction of the connector (short to power supply in connector)
- Malfunction of the wiring harness (short to power supply in the CAN-C main or sub bus lines)
- Malfunction of the ECU (ETACS-ECU, or ECUs on CAN-C lines failed)

**DIAGNOSIS****Required Special Tools:**

- MB991223: Harness Set
- MB992006: Extra Fine Probe
- MB991958: Scan Tool (M.U.T.-III Sub Assembly)
  - MB991824: Vehicle Communication Interface (V.C.I.)
  - MB991827: M.U.T.-III USB Cable
  - MB991910: M.U.T.-III Main Harness A
- MB992110: Power plant ECU check harness
- MB991997: ASC Check Harness

**STEP 1. Check the wiring harness between joint connector (CAN2) C-104 and steering wheel sensor connector C-209 for a short to power supply. Measure the voltage at joint connector (CAN2) C-104.**

- (1) Disconnect joint connector (CAN2), and measure the voltage at the wiring harness side of joint connector (CAN2).
- (2) Turn the ignition switch to the ON position.
- (3) Measure the voltage between joint connector (CAN2) terminal 7 and body ground.

**OK: 4.7 V or less**

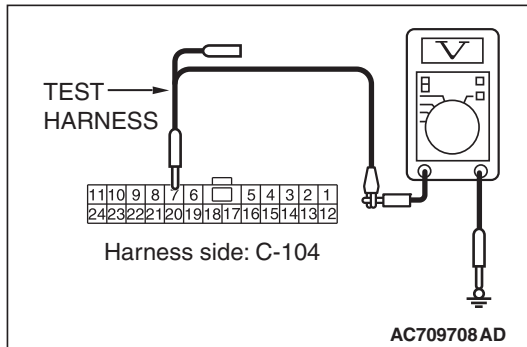

- (4) Measure the voltage between joint connector (CAN2) terminal 20 and body ground.

**OK: 4.7 V or less**

**Q: Do all the voltages measure 4.7 V or less?**

**YES :** Go to Step 2.

**NO :** Go to Step 10.

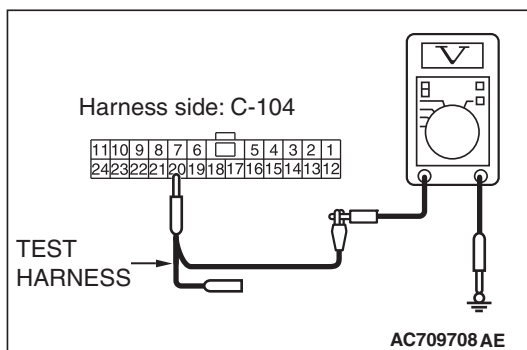



**STEP 2. Check the wiring harness between joint connector (CAN2) C-104 and AWC-ECU connector C-46 for a short to power supply. Measure the voltage at joint connector (CAN2) C-104.**

- (1) Disconnect joint connector (CAN2), and measure the voltage at the wiring harness side of joint connector (CAN2).
- (2) Turn the ignition switch to the ON position.
- (3) Measure the voltage between joint connector (CAN2) terminal 5 and body ground.

**OK: 4.7 V or less**

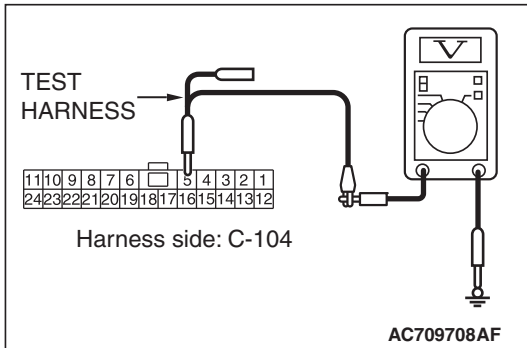

- (4) Measure the voltage between joint connector (CAN2) terminal 16 and body ground.

**OK: 4.7 V or less**

**Q: Do all the voltages measure 4.7 V or less?**

- YES :** Go to Step 3.  
**NO :** Go to Step 11.

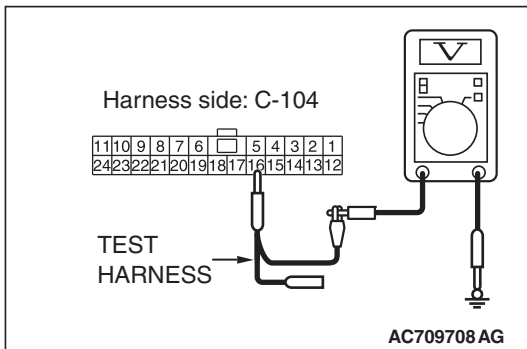

**STEP 3. Check the wiring harness between joint connector (CAN2) C-104 and ETACS-ECU connector C-301 for a short to power supply. Measure the voltage at joint connector (CAN2) C-104.**

- (1) Disconnect joint connector (CAN2), and measure the voltage at the wiring harness side of joint connector (CAN2).
- (2) Turn the ignition switch to the ON position.
- (3) Measure the voltage between joint connector (CAN2) terminal 6 and body ground.

**OK: 4.7 V or less**

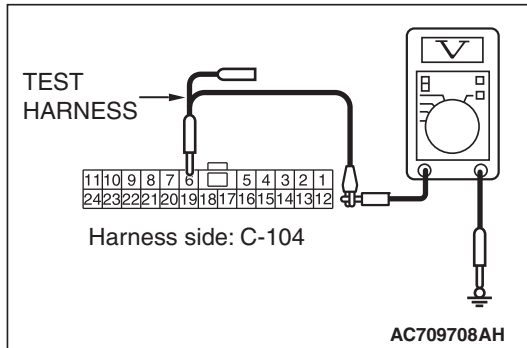

- (4) Measure the voltage between joint connector (CAN2) terminal 19 and body ground.

**OK: 4.7 V or less**

**Q: Do all the voltages measure 4.7 V or less?**

**YES :** Go to Step 4.

**NO :** Go to Step 12.

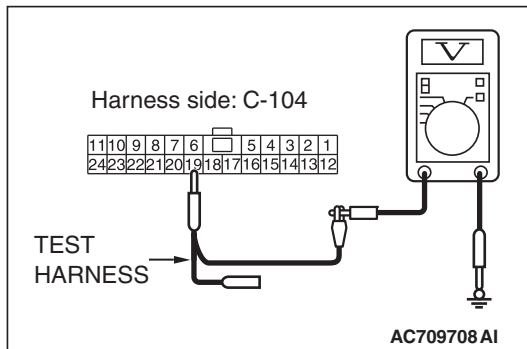

**STEP 4. Check the wiring harness between joint connector (CAN3) C-127 and ASC-ECU connector A-05 for a short to power supply. Measure the voltage at joint connector (CAN3) C-127.**

- (1) Disconnect joint connector (CAN3), and measure the voltage at the wiring harness side of joint connector (CAN3).
- (2) Turn the ignition switch to the ON position.
- (3) Measure the voltage between joint connector (CAN3) terminal 6 and body ground.

**OK: 4.7 V or less**

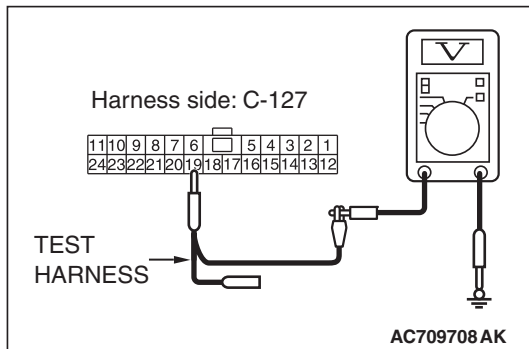
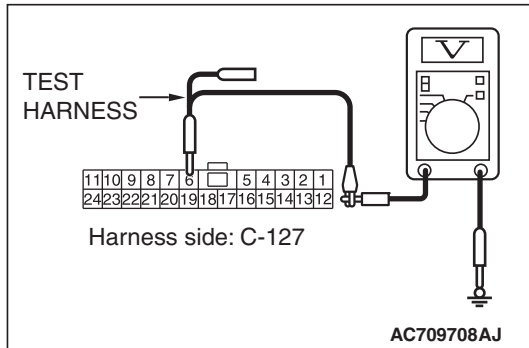

- (4) Measure the voltage between joint connector (CAN3) terminal 19 and body ground.

**OK: 4.7 V or less**

**Q: Do all the voltages measure 4.7 V or less?**

**YES <M/T> :** Go to Step 5.

**YES <TC-SST> :** Go to Step 6.

**NO :** Go to Step 13.

**STEP 5. Check the wiring harness between joint connector (CAN3) C-127 and ECM connector B-10 <M/T> for a short to power supply. Measure the voltage at joint connector (CAN3) C-127.**

- (1) Disconnect joint connector (CAN3), and measure the voltage at the wiring harness side of joint connector (CAN3).
- (2) Turn the ignition switch to the ON position.
- (3) Measure the voltage between joint connector (CAN3) terminal 4 and body ground.

**OK: 4.7 V or less**

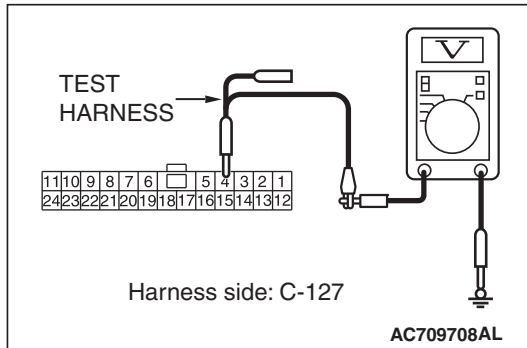

- (4) Measure the voltage between joint connector (CAN3) terminal 15 and body ground.

**OK: 4.7 V or less**

**Q: Do all the voltages measure 4.7 V or less?**

**YES :** Check intermediate connector C-131, and repair if necessary. If the intermediate connector is in good condition, repair the wiring harness between joint connector (CAN2) C-104 and joint connector (CAN3) C-127.

**NO :** Go to Step 14.

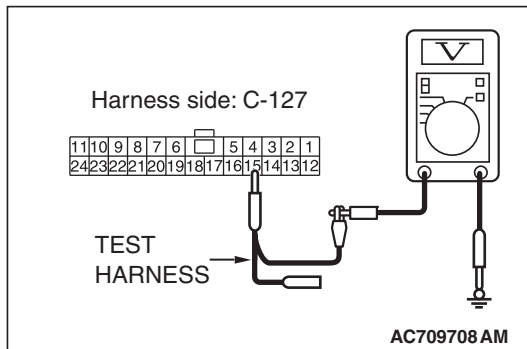

**STEP 6. Check the wiring harness between joint connector (CAN3) C-127 and shift lever connector C-27 for a short to power supply. Measure the voltage at joint connector (CAN3) C-127.**

- (1) Disconnect joint connector (CAN3), and measure the voltage at the wiring harness side of joint connector (CAN3).
- (2) Turn the ignition switch to the ON position.
- (3) Measure the voltage between joint connector (CAN3) terminal 7 and body ground.

**OK: 4.7 V or less**

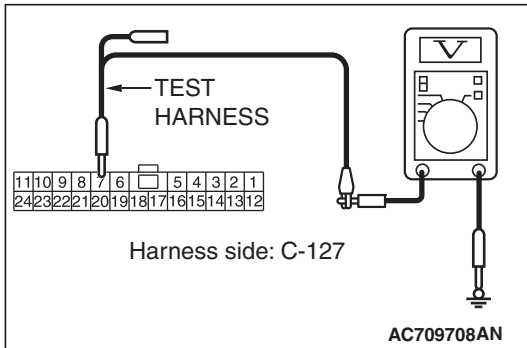

- (4) Measure the voltage between joint connector (CAN3) terminal 20 and body ground.

**OK: 4.7 V or less**

**Q: Do all the voltages measure 4.7 V or less?**

**YES :** Go to Step 7.

**NO :** Go to Step 15.

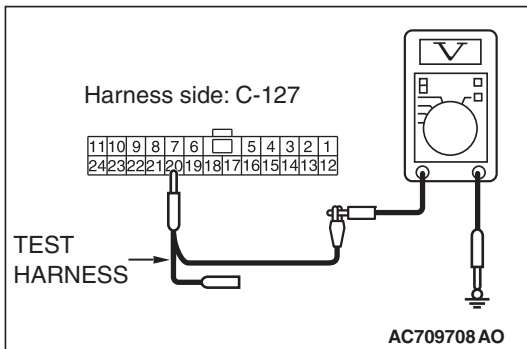

**STEP 7. Check the wiring harness between joint connector (CAN4) A-14 and ECM connector B-10 <TC-SST> for a short to power supply. Measure the voltage at joint connector (CAN4) A-14.**

- (1) Disconnect joint connector (CAN4), and measure the voltage at the wiring harness side of joint connector (CAN4).
- (2) Turn the ignition switch to the ON position.
- (3) Measure the voltage between joint connector (CAN4) terminal 7 and body ground.

**OK: 4.7 V or less**

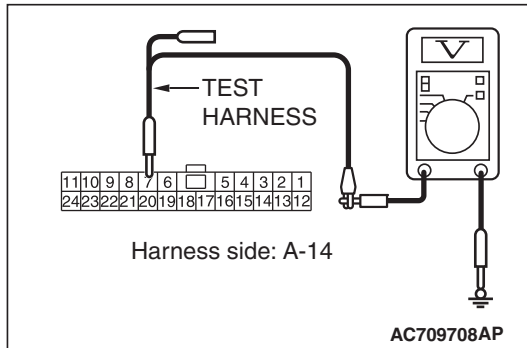

- (4) Measure the voltage between joint connector (CAN4) terminal 20 and body ground.

**OK: 4.7 V or less**

**Q: Do all the voltages measure 4.7 V or less?**

**YES :** Go to Step 8.

**NO :** Go to Step 14.

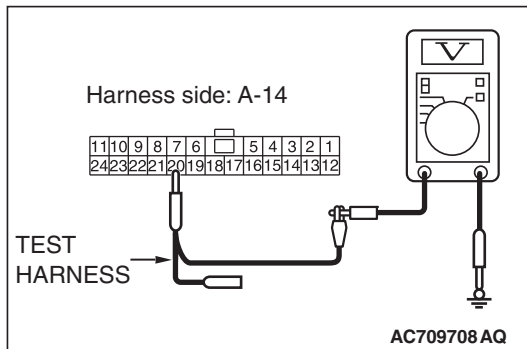

**STEP 8. Check the wiring harness between joint connector (CAN4) A-14 and transaxle assembly connector B-107 for a short to power supply. Measure the voltage at joint connector (CAN4) A-14.**

- (1) Disconnect joint connector (CAN4), and measure the voltage at the wiring harness side of joint connector (CAN4).
- (2) Turn the ignition switch to the ON position.
- (3) Measure the voltage between joint connector (CAN4) terminal 6 and body ground.

**OK: 4.7 V or less**

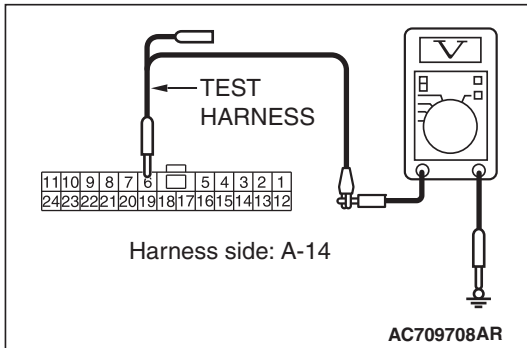

- (4) Measure the voltage between joint connector (CAN4) terminal 19 and body ground.

**OK: 4.7 V or less**

**Q: Do all the voltages measure 4.7 V or less?**

**YES :** Go to Step 9.

**NO :** Go to Step 16.

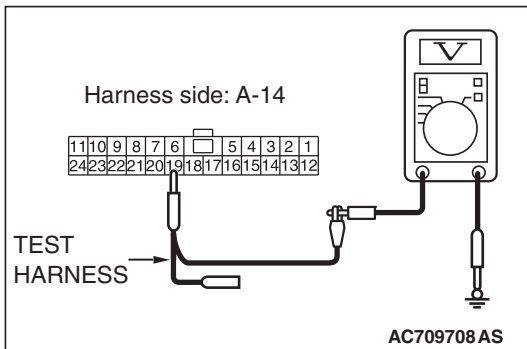

**STEP 9.** Check the wiring harness between joint connector (CAN3) C-127 and joint connector (CAN2) C-104 for a short to ground. Measure the resistance at joint connector (CAN3) C-127.

**⚠ CAUTION**

Disconnect the negative battery terminal. For details refer to P.54C-7.

**⚠ CAUTION**

A digital multimeter should be used. For details refer to P.54C-7.

**⚠ CAUTION**

The test wiring harness should be used. For details refer to P.54C-7.

- (1) Disconnect joint connector (CAN3), and measure the resistance at the wiring harness side of joint connector (CAN3).
- (2) Turn the ignition switch to the ON position.
- (3) Measure the voltage between joint connector (CAN3) terminal 5 and body ground.

**OK: 4.7 V or less**

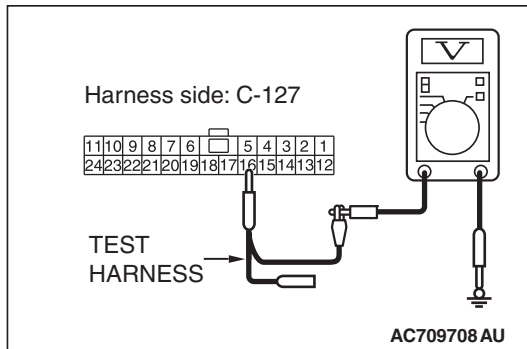
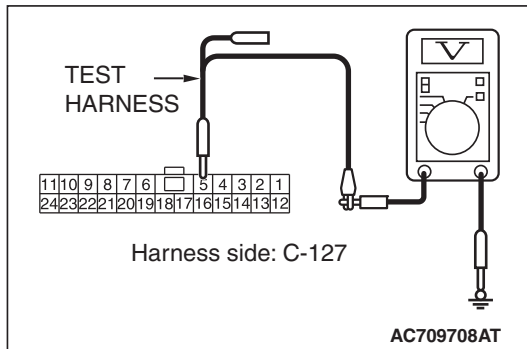

- (4) Measure the voltage between joint connector (CAN3) terminal 16 and body ground.

**OK: 4.7 V or less**

**Q: Do all the voltages measure 4.7 V or less?**

**YES :** Check intermediate connector A-13, and repair if necessary. If the intermediate connector is in good condition, repair the wiring harness between joint connector (CAN3) C-127 and joint connector (CAN4) A-14.

**NO :** Check intermediate connector C-131, and repair if necessary. If the intermediate connector is in good condition, repair the wiring harness between joint connector (CAN3) C-127 and joint connector (CAN2) C-104.



**STEP 10.** Using scan tool MB991958, diagnose the CAN bus line. (checking the steering wheel sensor for internal short to ground)

**⚠ CAUTION**

Strictly observe the specified wiring harness repair procedure. For details refer to [P.54C-7](#).

**⚠ CAUTION**

To prevent damage to scan tool MB991958, always turn the ignition switch to the "LOCK" (OFF) position before connecting or disconnecting scan tool MB991958.

- (1) Disconnect ETACS-ECU connector C-301.
- (2) Connect scan tool MB991958 to the data link connector.
- (3) Turn the ignition switch to the "ON" position.

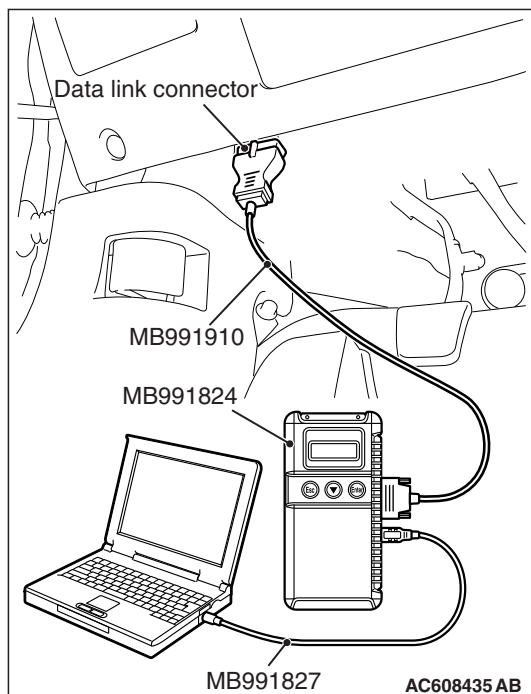

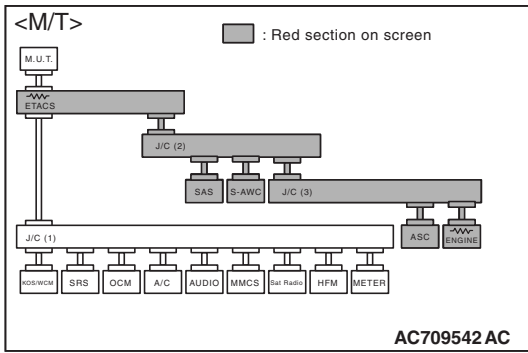

(4) Diagnose CAN bus lines, and check if the scan tool MB991958 screen is as shown in the figure.

**OK:** The display of the scan tool MB991958 is as shown in the figure.

**Q:** Does scan tool MB991958 screen correspond to the illustration?

**YES :** Repair the wiring harness between steering wheel sensor connector C-209 and joint connector (CAN2) C-104.

**NO :** Check steering wheel sensor connector C-209, and repair if necessary. If the steering wheel sensor connector is in good condition, replace the steering wheel sensor.

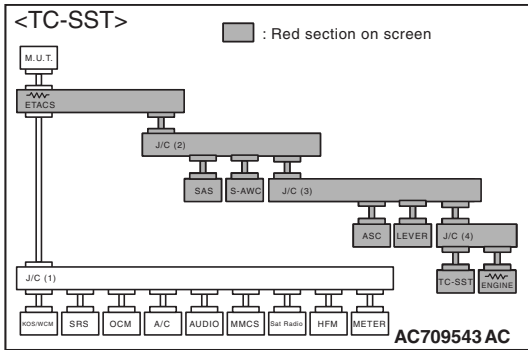

**STEP 11.** Using scan tool MB991958, diagnose the CAN bus line. (checking the AWC-ECU for internal short to ground)

**⚠ CAUTION**

Strictly observe the specified wiring harness repair procedure. For details refer to [P.54C-7](#).

**⚠ CAUTION**

To prevent damage to scan tool MB991958, always turn the ignition switch to the "LOCK" (OFF) position before connecting or disconnecting scan tool MB991958.

- (1) Disconnect AWC-ECU connector C-46.
- (2) Connect scan tool MB991958 to the data link connector.
- (3) Turn the ignition switch to the "ON" position.

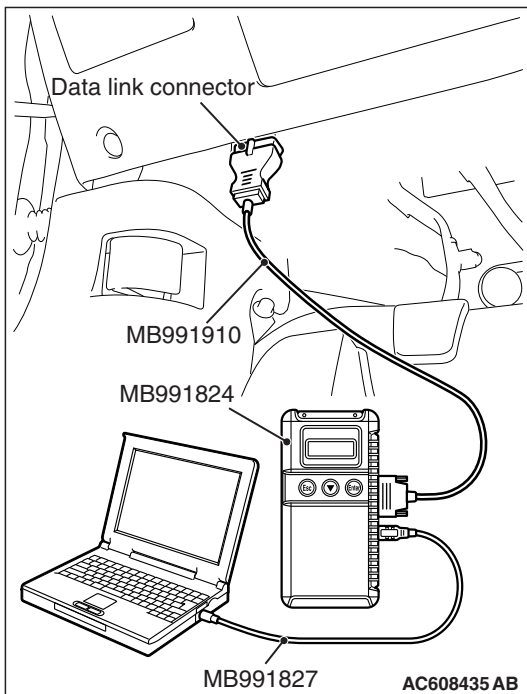

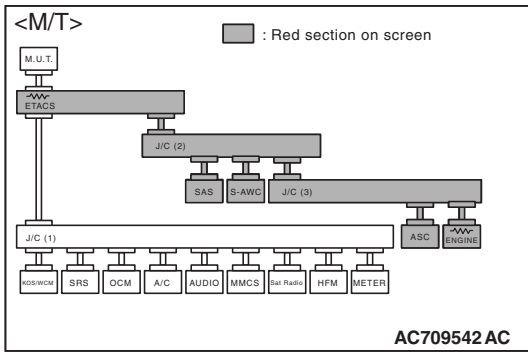

(4) Diagnose CAN bus lines, and check if the scan tool MB991958 screen is as shown in the figure.

**OK:** The display of the scan tool MB991958 is as shown in the figure.

**Q:** Does scan tool MB991958 screen correspond to the illustration?

**YES :** Repair the wiring harness between AWC-ECU connector C-46 and joint connector (CAN2) C-104.

**NO :** Check AWC-ECU connector C-46, and repair if necessary. If the AWC-ECU connector is in good condition, replace the AWC-ECU.

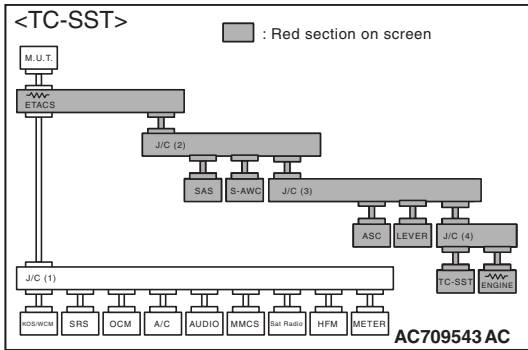

**STEP 12.** Check the wiring harness between joint connector (CAN2) C-104 and ETACS-ECU connector C-301 for short to power supply (voltage measurement).

**⚠ CAUTION**

A digital multimeter should be used. For details refer to [P.54C-7](#).

**⚠ CAUTION**

The test wiring harness should be used. For details refer to [P.54C-7](#).

**⚠ CAUTION**

Strictly observe the specified wiring harness repair procedure. For details refer to [P.54C-7](#).

- (1) Disconnect ETACS-ECU connector and joint connector (CAN2), and measure at the wiring harness side.
- (2) Turn the ignition switch to the ON position.
- (3) Measure the voltage between joint connector (CAN2) terminal 6 and body ground.

**OK: 1 V or less**

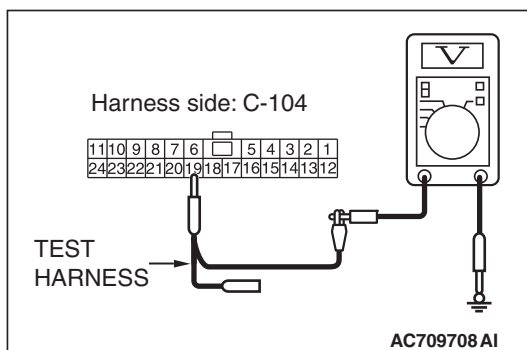
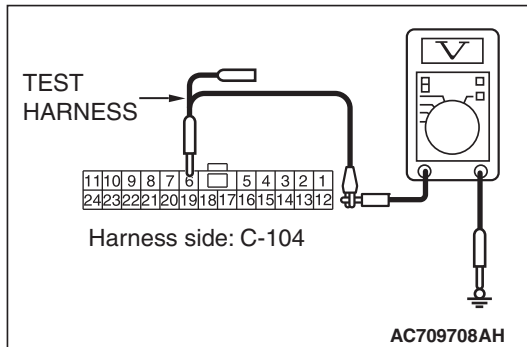

- (4) Measure the voltage between joint connector (CAN2) terminal 19 and body ground.

**OK: 1 V or less**

**Q: Do all the voltages measure 1 V or less?**

**YES :** Check ETACS-ECU connector C-301, and repair if necessary. If the ETACS-ECU connector is in good condition, replace the ETACS-ECU.

**NO :** Repair the wiring harness between ETACS-ECU connector C-301 and joint connector (CAN2) C-104.

**STEP 13.** Using scan tool MB991958, diagnose the CAN bus line. (checking the ASC-ECU for internal short to ground)

**⚠ CAUTION**

Strictly observe the specified wiring harness repair procedure. For details refer to [P.54C-7](#).

**⚠ CAUTION**

To prevent damage to scan tool MB991958, always turn the ignition switch to the "LOCK" (OFF) position before connecting or disconnecting scan tool MB991958.

- (1) Disconnect ASC-ECU connector A-05.
- (2) Connect scan tool MB991958 to the data link connector.
- (3) Turn the ignition switch to the "ON" position.

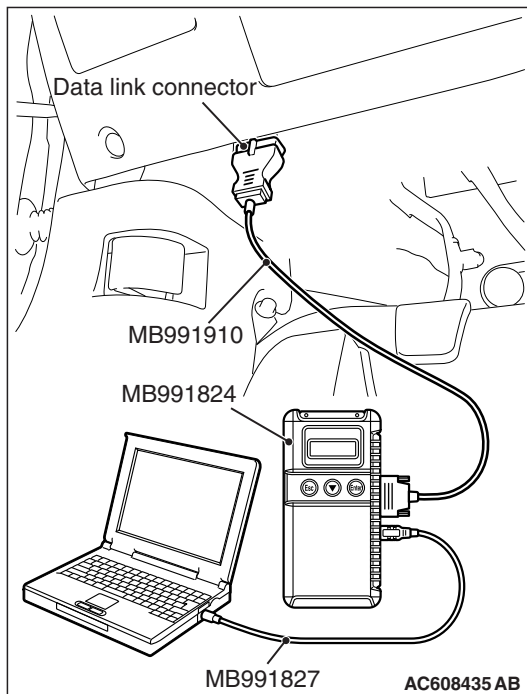

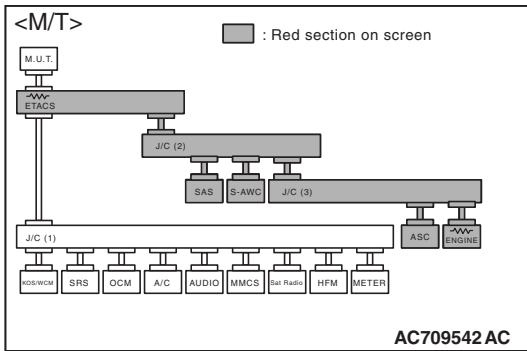

(4) Diagnose CAN bus lines, and check if the scan tool MB991958 screen is as shown in the figure.

**OK:** The display of the scan tool MB991958 is as shown in the figure.

**Q:** Does scan tool MB991958 screen correspond to the illustration?

**YES :** Repair the wiring harness between ASC-ECU connector A-05 and joint connector (CAN3) C-127.

**NO :** Check ASC-ECU connector A-05, and repair if necessary. If the ASC-ECU connector is in good condition, replace the ASC-ECU.

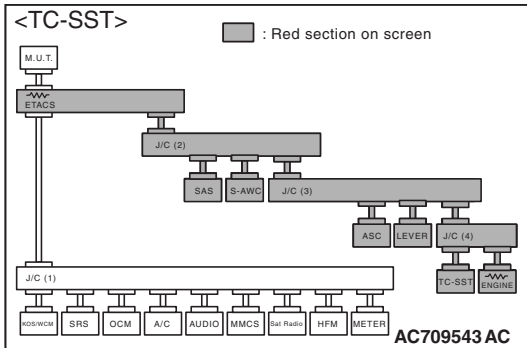

**STEP 14.** Using scan tool MB991958, diagnose the CAN bus line. (checking the ECM for internal short to ground)

**⚠ CAUTION**

Strictly observe the specified wiring harness repair procedure. For details refer to [P.54C-7](#).

**⚠ CAUTION**

To prevent damage to scan tool MB991958, always turn the ignition switch to the "LOCK" (OFF) position before connecting or disconnecting scan tool MB991958.

- (1) Disconnect ECM connector B-10.
- (2) Connect scan tool MB991958 to the data link connector.
- (3) Turn the ignition switch to the "ON" position.

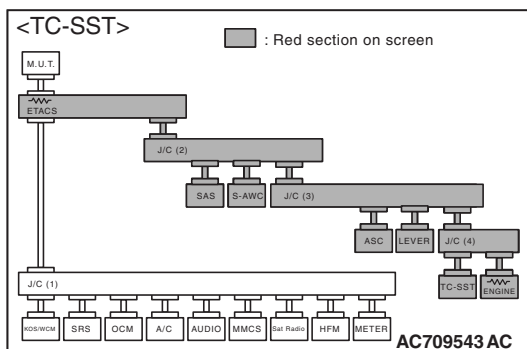
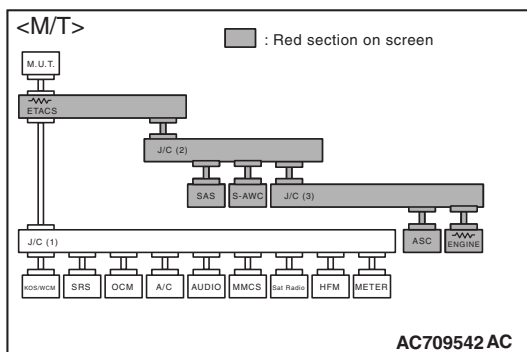
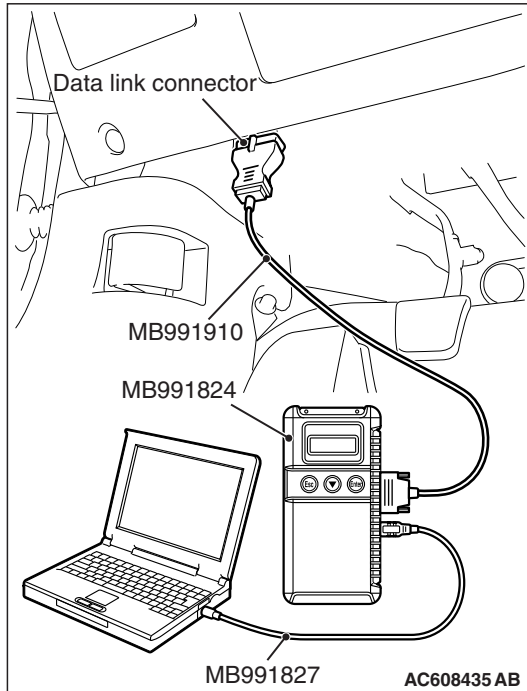

- (4) Diagnose CAN bus lines, and check if the scan tool MB991958 screen is as shown in the figure.

**OK:** The display of the scan tool MB991958 is as shown in the figure.

**Q:** Does scan tool MB991958 screen correspond to the illustration?

**YES :** Repair the wiring harness between ECM connector B-10 and joint connector (CAN3) C-127 <M/T>, or check intermediate connector A-13, and repair if necessary. If the intermediate connector is in good condition, repair the wiring harness between ECM connector B-10 and joint connector (CAN4) A-14 <TC-SST>.

**NO :** Check ECM connector B-10, and repair if necessary. If the ECM connector is in good condition, replace the ECM.



**STEP 15.** Using scan tool MB991958, diagnose the CAN bus line. (checking the shift lever for internal short to ground)

**⚠ CAUTION**

Strictly observe the specified wiring harness repair procedure. For details refer to [P.54C-7](#).

**⚠ CAUTION**

To prevent damage to scan tool MB991958, always turn the ignition switch to the "LOCK" (OFF) position before connecting or disconnecting scan tool MB991958.

- (1) Disconnect shift lever connector C-27.
- (2) Connect scan tool MB991958 to the data link connector.
- (3) Turn the ignition switch to the "ON" position.

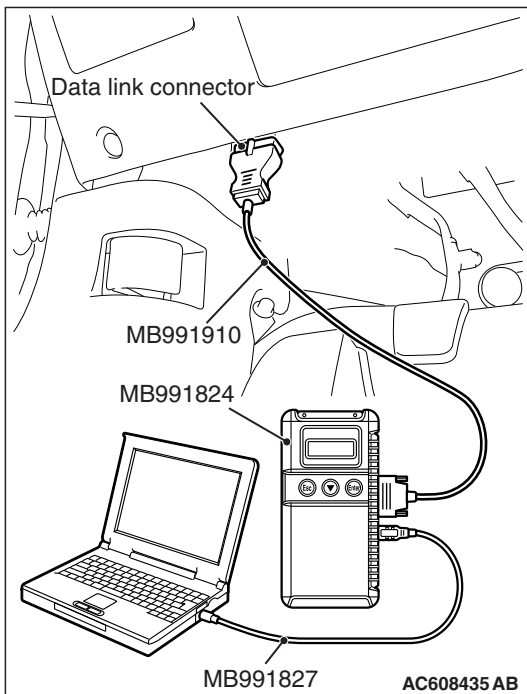

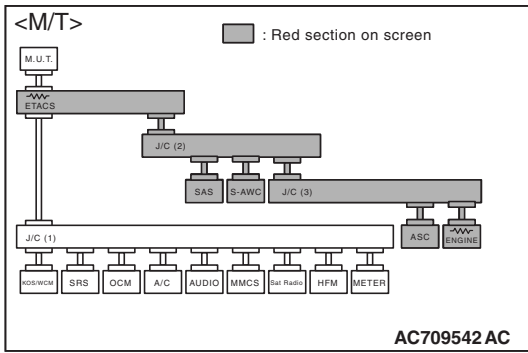

(4) Diagnose CAN bus lines, and check if the scan tool MB991958 screen is as shown in the figure.

**OK:** The display of the scan tool MB991958 is as shown in the figure.

**Q:** Does scan tool MB991958 screen correspond to the illustration?

**YES :** Repair the wiring harness between shift lever connector C-27 and joint connector (CAN3) C-127.

**NO :** Check shift lever connector C-27, and repair if necessary. If the shift lever connector is in good condition, replace the shift lever.

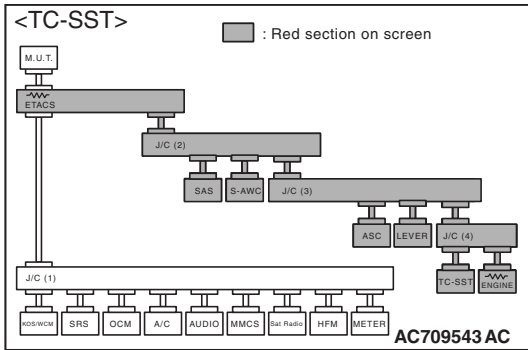

**STEP 16.** Using scan tool MB991958, diagnose the CAN bus line. (checking the TC-SST-ECU for internal short to ground)

**⚠ CAUTION**

Strictly observe the specified wiring harness repair procedure. For details refer to [P.54C-7](#).

**⚠ CAUTION**

To prevent damage to scan tool MB991958, always turn the ignition switch to the "LOCK" (OFF) position before connecting or disconnecting scan tool MB991958.

- (1) Disconnect transaxle assembly connector B-107.
- (2) Connect scan tool MB991958 to the data link connector.
- (3) Turn the ignition switch to the "ON" position.

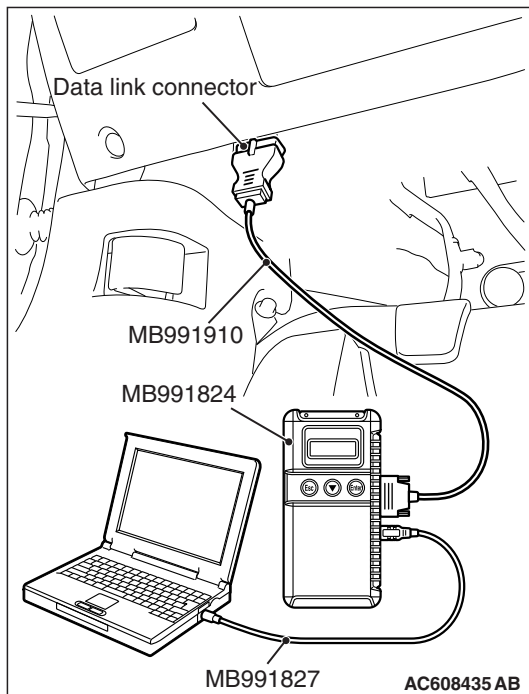

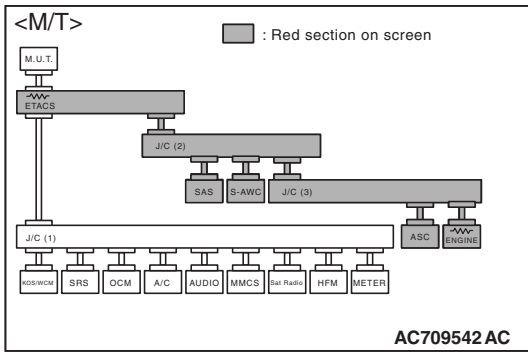

(4) Diagnose CAN bus lines, and check if the scan tool MB991958 screen is as shown in the figure.

**OK:** The display of the scan tool MB991958 is as shown in the figure.

**Q:** Does scan tool MB991958 screen correspond to the illustration?

**YES :** Repair the wiring harness between transaxle assembly connector B-107 and joint connector (CAN4) A-14.

**NO :** Check transaxle assembly connector B-107, and repair if necessary. If the transaxle assembly connector is in good condition, replace the transaxle assembly.

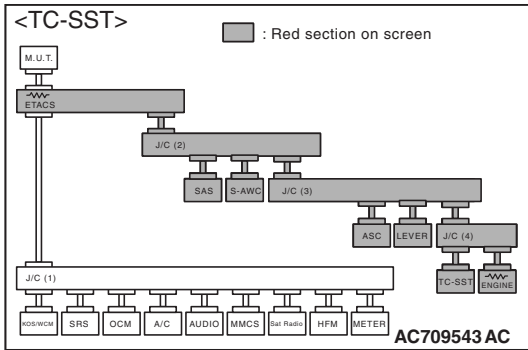

**DIAGNOSTIC ITEM 6: Diagnose when the scan tool cannot receive the data sent by AWC-ECU.**

**⚠ CAUTION**

When servicing a CAN bus line, ground yourself by touching a metal object such as an unpainted water pipe. If you fail to do so, a component connected to the CAN bus line may be damaged.

CAN-C Communication Circuit <M/T>

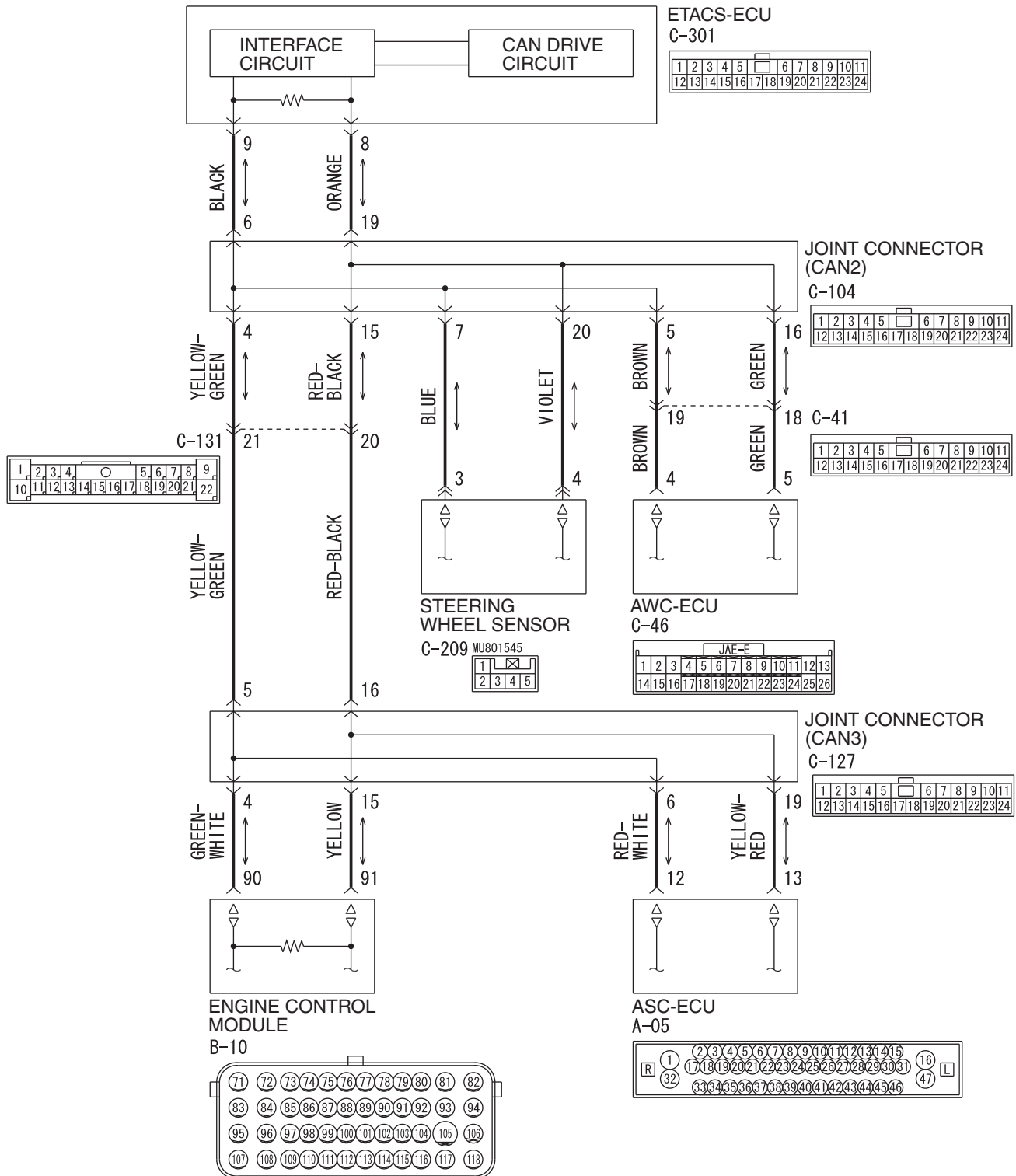

CAN-C Communication Circuit <TC-SST>

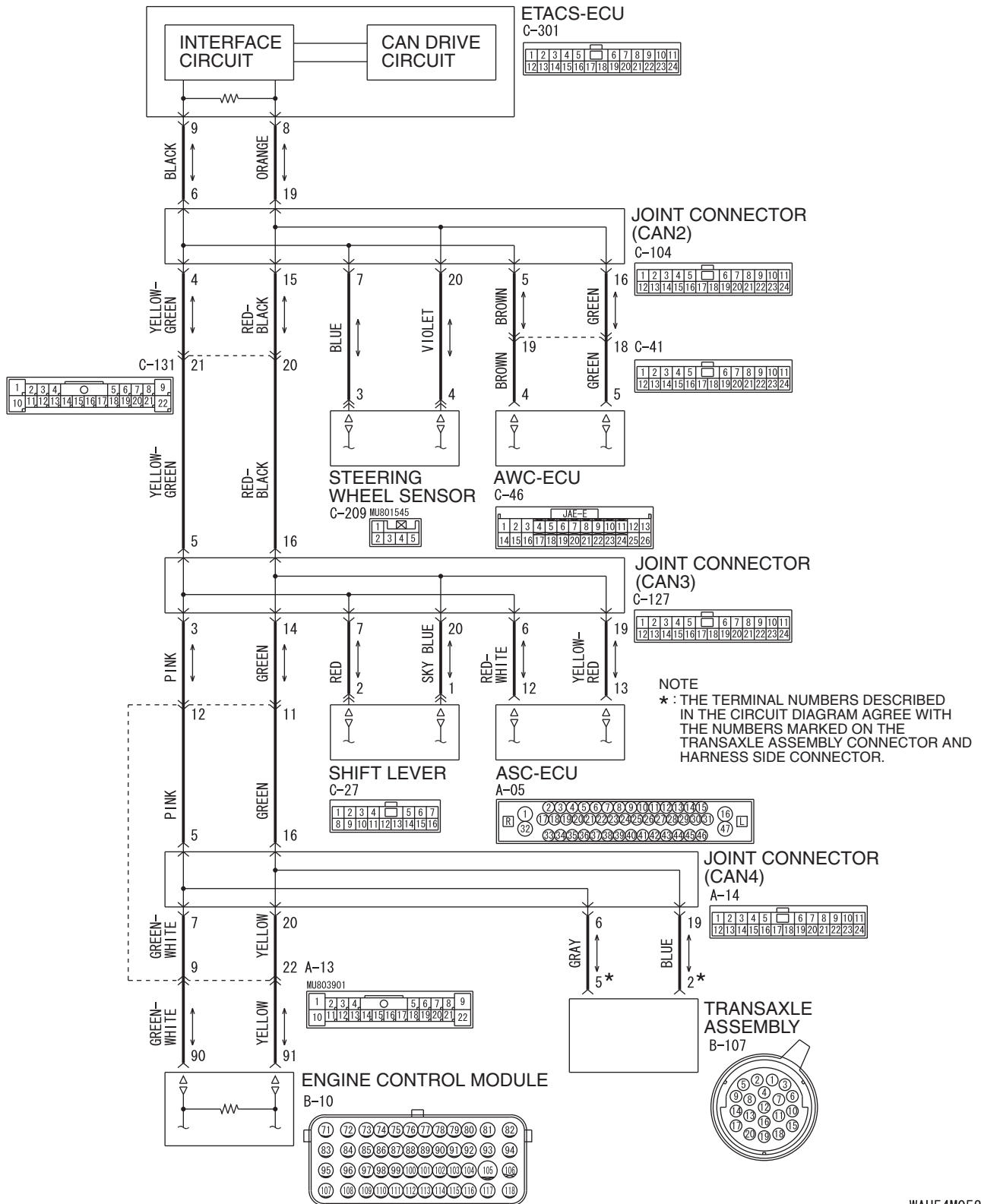

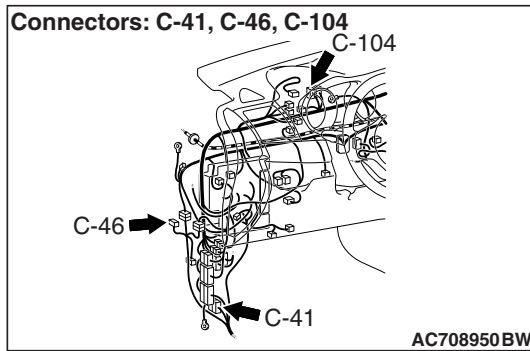

## FUNCTION

If the scan tool MB991958 cannot communicate with the AWC-ECU, this diagnosis result will be set.

## TROUBLE JUDGMENT CONDITIONS

If a communication flag is not set for the AWC-ECU, the ETACS-ECU determines that there is a failure.

## TROUBLESHOOTING HINTS

- Malfunction of the connector [joint connector (CAN2), AWC-ECU connector or intermediate connector failed improperly connected]
- Malfunction of the wiring harness [open circuit between the AWC-ECU and the joint connector (CAN2), power supply circuit to the AWC-ECU]
- Malfunction of the AWC-ECU

## DIAGNOSIS

### Required Special Tools:

- MB991223: Harness Set
- MB992006: Extra Fine Probe

**STEP 1. Check joint connector (CAN2) C-104 and AWC-ECU connector C-46 and intermediate connector C-41 for loose, corroded or damaged terminals, or terminals pushed back in the connector.**

### **⚠ CAUTION**

The strand end of the twisted wire should be within 10 cm (4 inches) from the connector. For details refer to [P.54C-7](#).

**Q: Are joint connector (CAN2) C-104 and AWC-ECU connector C-46 and intermediate connector C-41 in good condition?**

**YES :** Go to Step 2.

**NO :** Repair the damaged parts.

**STEP 2. Check the wiring harness between joint connector (CAN2) C-104 and AWC-ECU connector C-46 for open circuit.**

**⚠ CAUTION**

**Strictly observe the specified wiring harness repair procedure. For details refer to P.54C-7.**

- (1) Disconnect joint connector (CAN2) C-104 and AWC-ECU connector C-46, and check the wiring harness.
- (2) Check the wiring harness between joint connector (CAN2) C-104 (terminal 5) and AWC-ECU connector C-46 (terminal 4)

**OK: Continuity exists (2 Ω or less)**

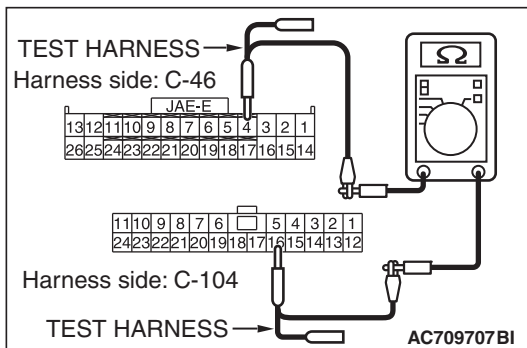
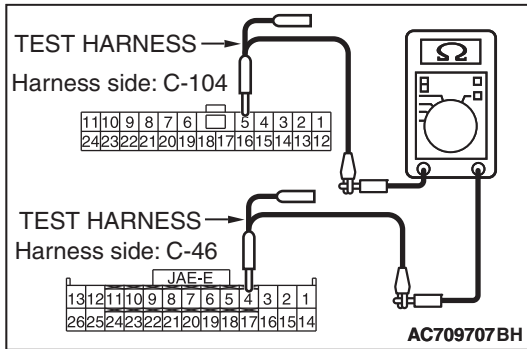

- (3) Check the wiring harness between joint connector (CAN2) C-104 (terminal 16) and AWC-ECU connector C-46 (terminal 5)

**OK: Continuity exists (2 Ω or less)**

**Q: Is the wiring harness between joint connector (CAN2) C-104 and AWC-ECU connector C-46 in good condition?**

**YES :** Check the power supply circuit of the AWC-ECU. Refer to GROUP 22A, Troubleshooting P.22A-12 <S-AWC>.

**NO :** Repair the wiring harness between joint connector (CAN2) C-104 and AWC-ECU connector C-46.



**DIAGNOSTIC ITEM 7: Diagnose when the scan tool cannot receive the data sent by steering wheel sensor.**

**CAUTION**

When servicing a CAN bus line, ground yourself by touching a metal object such as an unpainted water pipe. If you fail to do so, a component connected to the CAN bus line may be damaged.

CAN-C Communication Circuit <M/T>

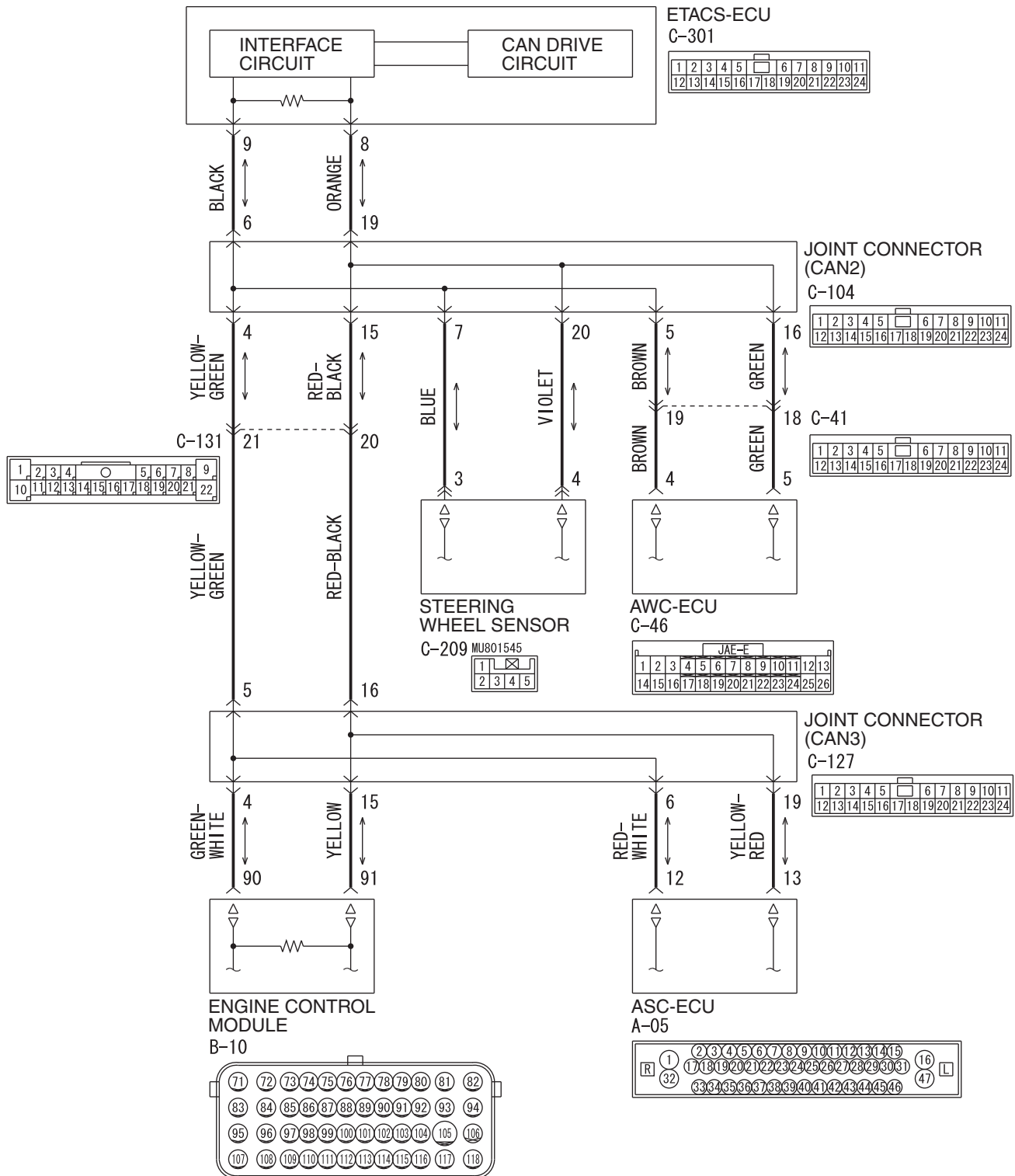

CAN-C Communication Circuit <TC-SST>

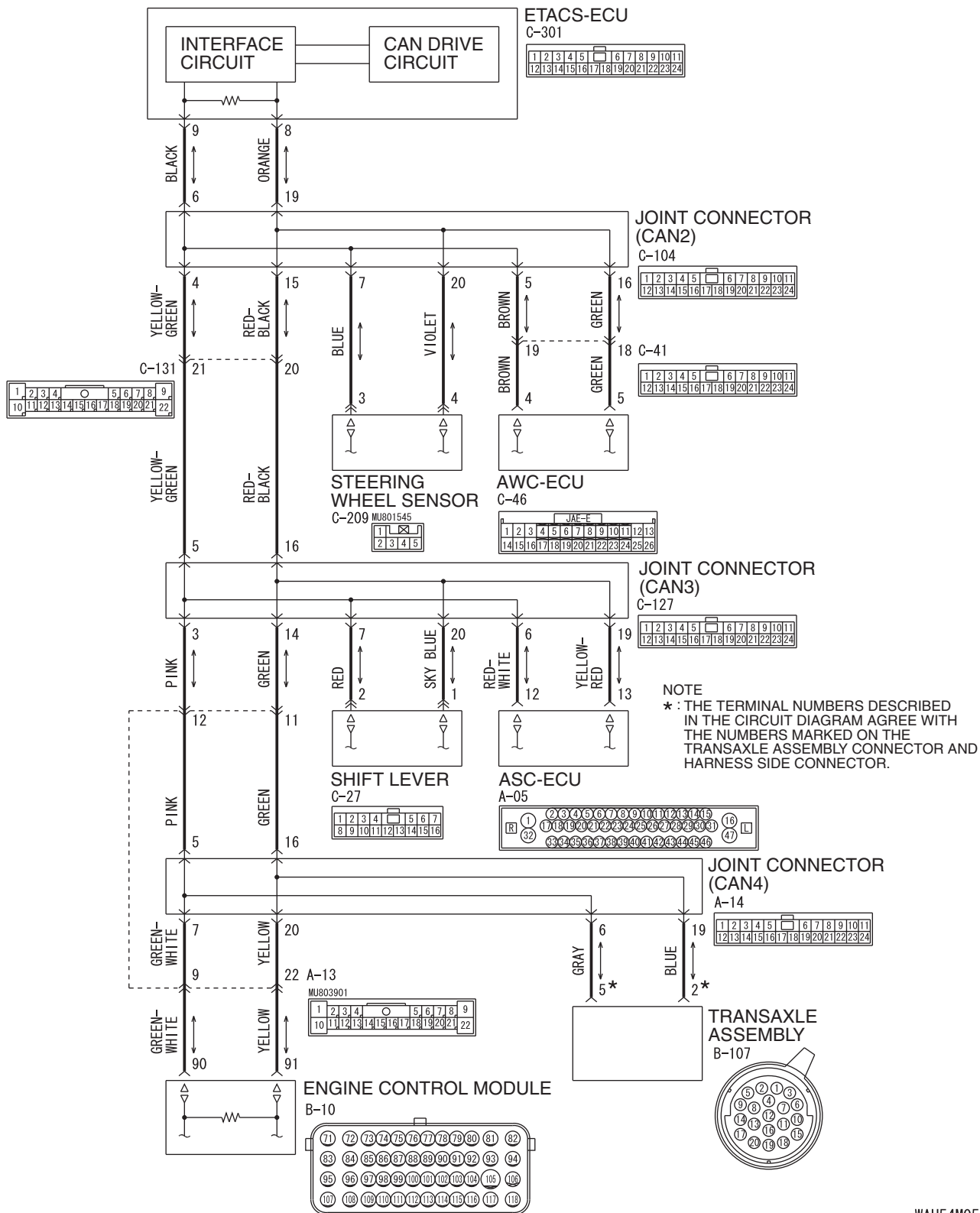

WAH54M052A

Connector: C-104

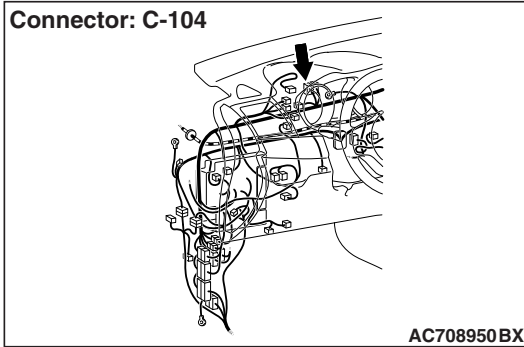

## FUNCTION

If the scan tool MB991958 cannot communicate with the steering wheel sensor, this diagnosis result will be set.

## TROUBLE JUDGMENT CONDITIONS

If a communication flag is not set for the steering wheel sensor, the ETACS-ECU determines that there is a failure.

Connector: C-209

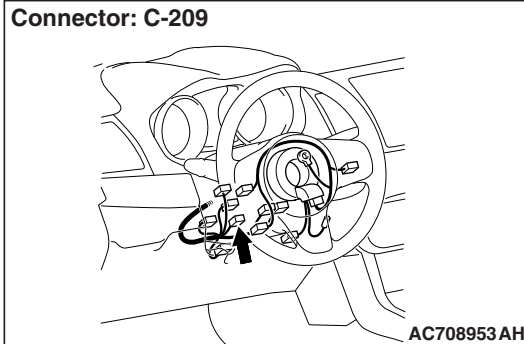

## TROUBLESHOOTING HINTS

- Malfunction of the connector [joint connector (CAN2) or steering wheel sensor connector improperly connected]
- Malfunction of the wiring harness [open circuit between the steering wheel sensor and the joint connector (CAN2), power supply circuit to the steering wheel sensor]
- Malfunction of the steering wheel sensor

## DIAGNOSIS

### Required Special Tools:

- MB991223: Harness Set
- MB992006: Extra Fine Probe

**STEP 1. Check joint connector (CAN2) C-104 and steering wheel sensor connector C-209 for loose, corroded or damaged terminals, or terminals pushed back in the connector.**

### **⚠ CAUTION**

The strand end of the twisted wire should be within 10 cm (4 inches) from the connector. For details refer to [P.54C-7](#).

**Q: Are joint connector (CAN2) C-104 and steering wheel sensor connector C-209 in good condition?**

**YES :** Go to Step 2.

**NO :** Repair the damaged parts.

**STEP 2. Check the wiring harness between joint connector (CAN2) C-104 and steering wheel sensor connector C-209 for open circuit.**

**⚠ CAUTION**

**Strictly observe the specified wiring harness repair procedure. For details refer to P.54C-7.**

- (1) Disconnect joint connector (CAN2) C-104 and steering wheel sensor connector C-209, and check the wiring harness.
- (2) Check the wiring harness between joint connector (CAN2) C-104 (terminal 7) and steering wheel sensor connector C-209 (terminal 3)

**OK: Continuity exists ( $2 \Omega$  or less)**

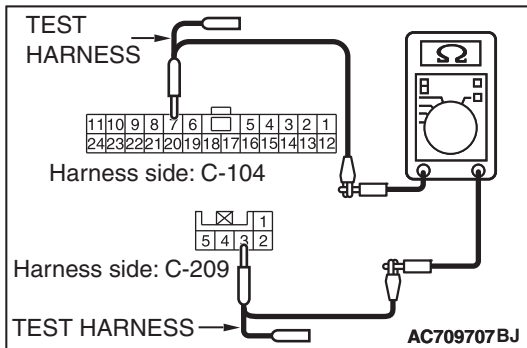

- (3) Check the wiring harness between joint connector (CAN2) C-104 (terminal 20) and steering wheel sensor connector C-209 (terminal 4)

**OK: Continuity exists ( $2 \Omega$  or less)**

**Q: Is the wiring harness between joint connector (CAN2) C-104 and steering wheel sensor connector C-209 in good condition?**

**YES :** Check the power supply circuit of the steering wheel sensor. Refer to GROUP 35C, Troubleshooting

**P.35C-196.**

**NO :** Repair the wiring harness between joint connector (CAN2) C-104 and steering wheel sensor connector C-209.

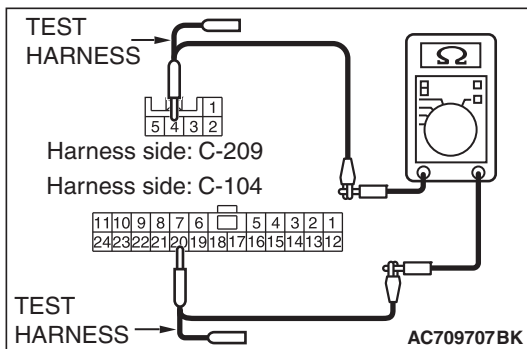

**DIAGNOSTIC ITEM 8: Diagnose when the scan tool cannot receive the data sent by shift lever.**  
<TC-SST>

**CAUTION**

When servicing a CAN bus line, ground yourself by touching a metal object such as an unpainted water pipe. If you fail to do so, a component connected to the CAN bus line may be damaged.

CAN-C Communication Circuit <TC-SST>

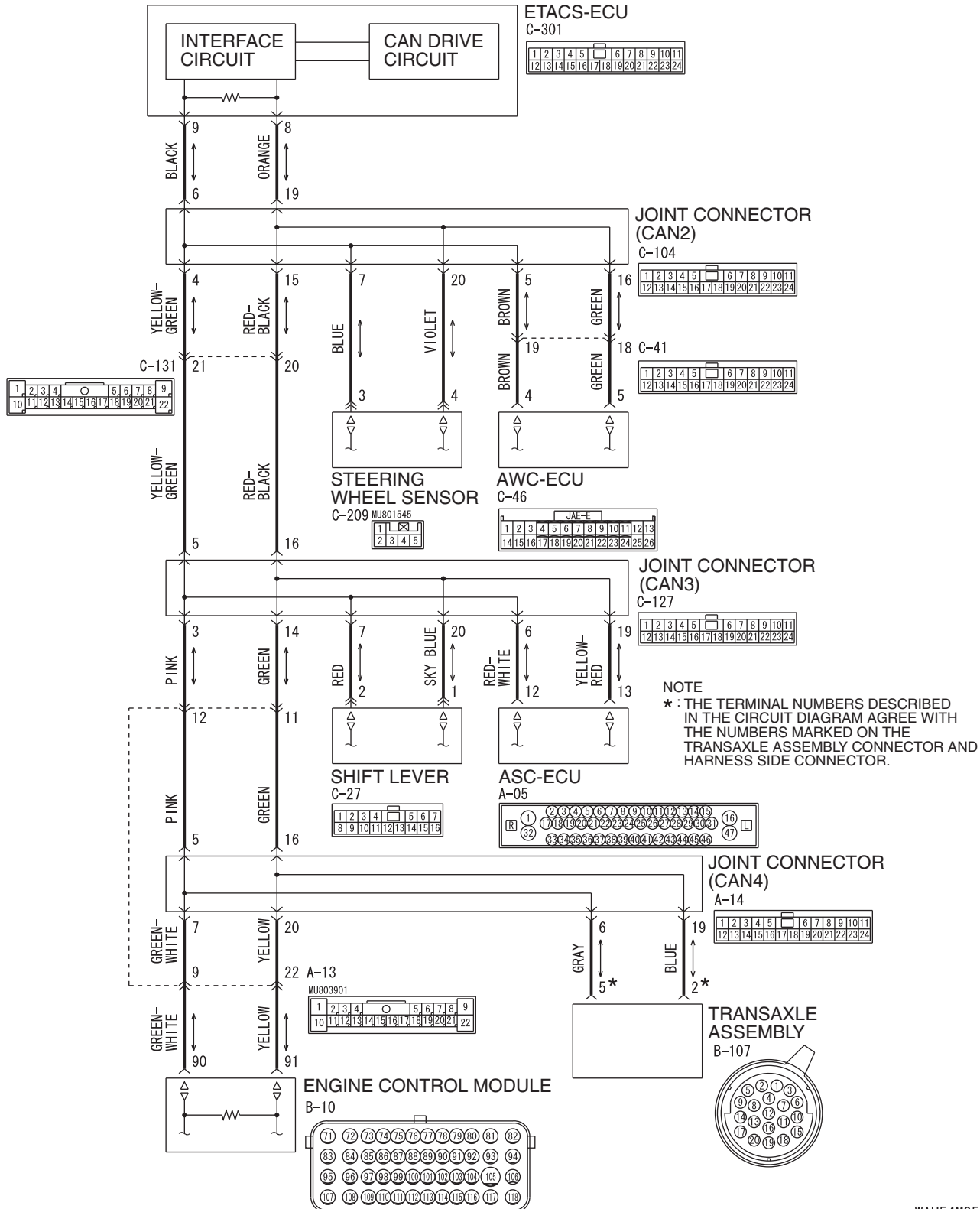

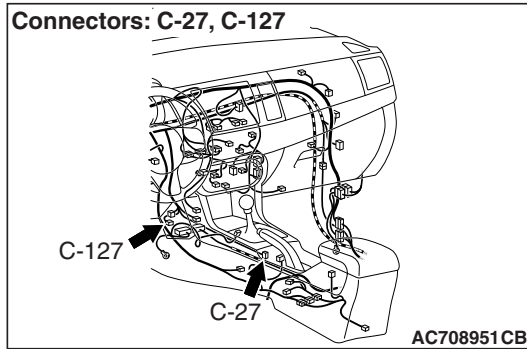

## FUNCTION

If the scan tool MB991958 cannot communicate with the shift lever, this diagnosis result will be set.

## TROUBLE JUDGMENT CONDITIONS

If a communication flag is not set for the shift lever, the ETACS-ECU determines that there is a failure.

## TROUBLESHOOTING HINTS

- Malfunction of the connector [joint connector (CAN3) or shift lever connector improperly connected]
- Malfunction of the wiring harness [open circuit between the shift lever and the joint connector (CAN3), power supply circuit to the shift lever]
- Malfunction of the shift lever

## DIAGNOSIS

### Required Special Tools:

- MB991223: Harness Set
- MB992006: Extra Fine Probe

**STEP 1. Check joint connector (CAN3) C-127 and shift lever connector C-27 for loose, corroded or damaged terminals, or terminals pushed back in the connector.**

### **⚠ CAUTION**

The strand end of the twisted wire should be within 10 cm (4 inches) from the connector. For details refer to [P.54C-7](#).

**Q: Are joint connector (CAN3) C-127 and shift lever connector C-27 in good condition?**

**YES :** Go to Step 2.

**NO :** Repair the damaged parts.

**STEP 2. Check the wiring harness between joint connector (CAN3) C-127 and shift lever connector C-27.**

**⚠ CAUTION**

**Strictly observe the specified wiring harness repair procedure. For details refer to P.54C-7.**

- (1) Disconnect joint connector (CAN3) C-127 and shift lever connector C-27, and check the wiring harness.
- (2) Check the wiring harness between joint connector (CAN3) C-127 (terminal 7) and shift lever connector C-27 (terminal 2)

**OK: Continuity exists (2 Ω or less)**

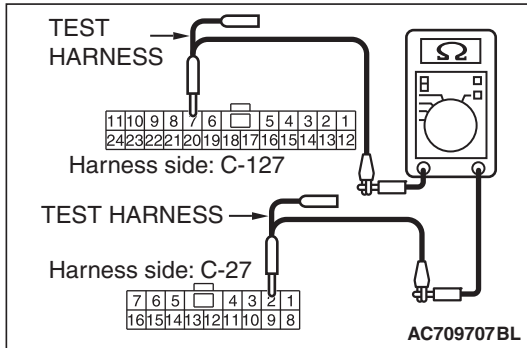

- (3) Check the wiring harness between joint connector (CAN3) C-127 (terminal 20) and shift lever connector C-27 (terminal 1)

**OK: Continuity exists (2 Ω or less)**

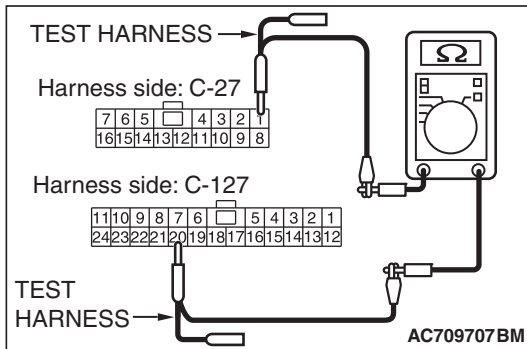

**Q: Is the wiring harness between joint connector (CAN3) C-127 and shift lever connector C-27 in good condition?**

**YES :** Check the power supply circuit of the shift lever. Refer to GROUP 22C, Troubleshooting P.22C-370 <shift lever>.

**NO :** Repair the wiring harness between joint connector (CAN3) C-127 and shift lever connector C-27.

**DIAGNOSTIC ITEM 9: Diagnose when the scan tool cannot receive the data sent by ASC-ECU.**

**CAUTION**

When servicing a CAN bus line, ground yourself by touching a metal object such as an unpainted water pipe. If you fail to do so, a component connected to the CAN bus line may be damaged.

CAN-C Communication Circuit <M/T>

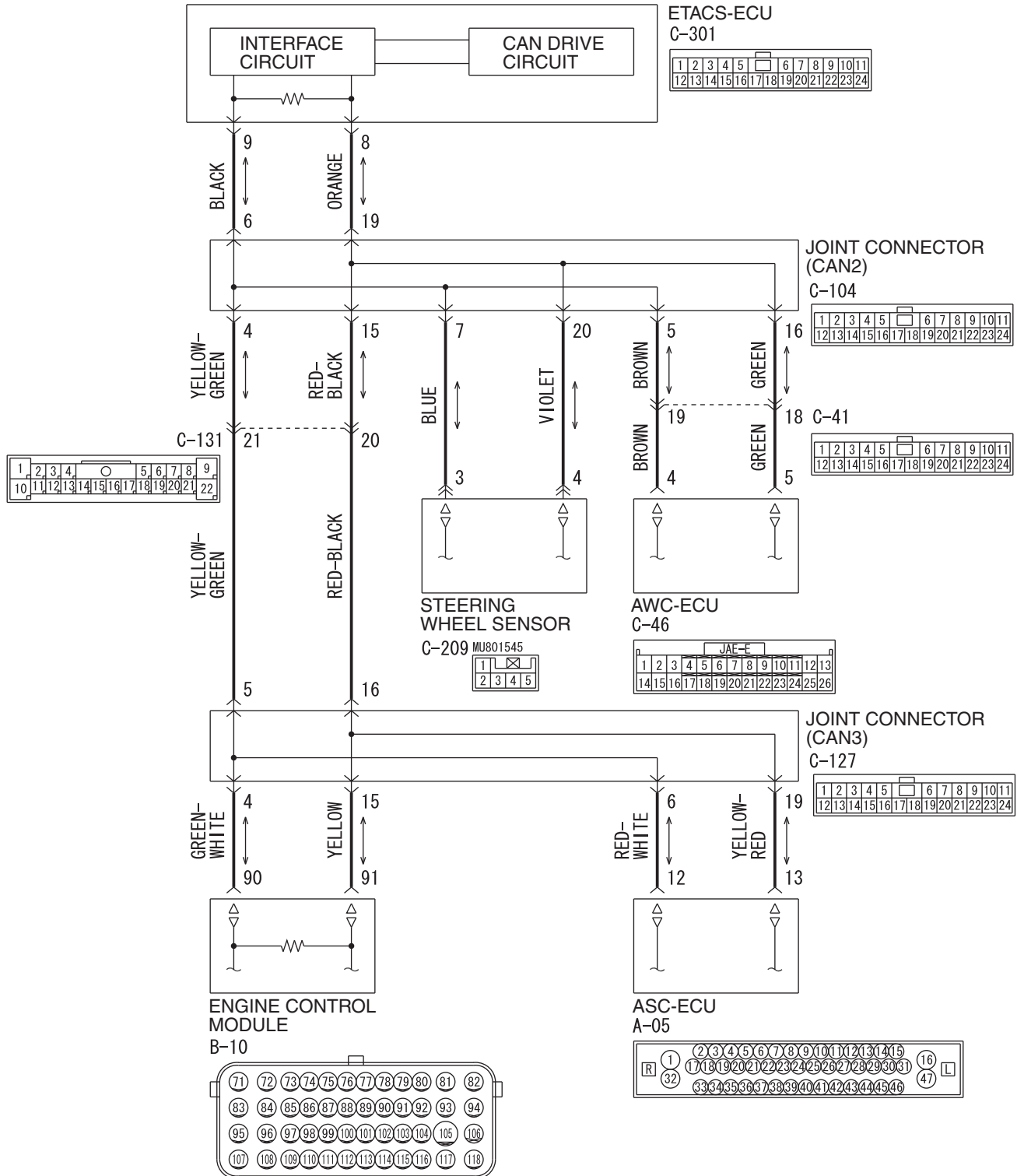



CAN-C Communication Circuit <TC-SST>

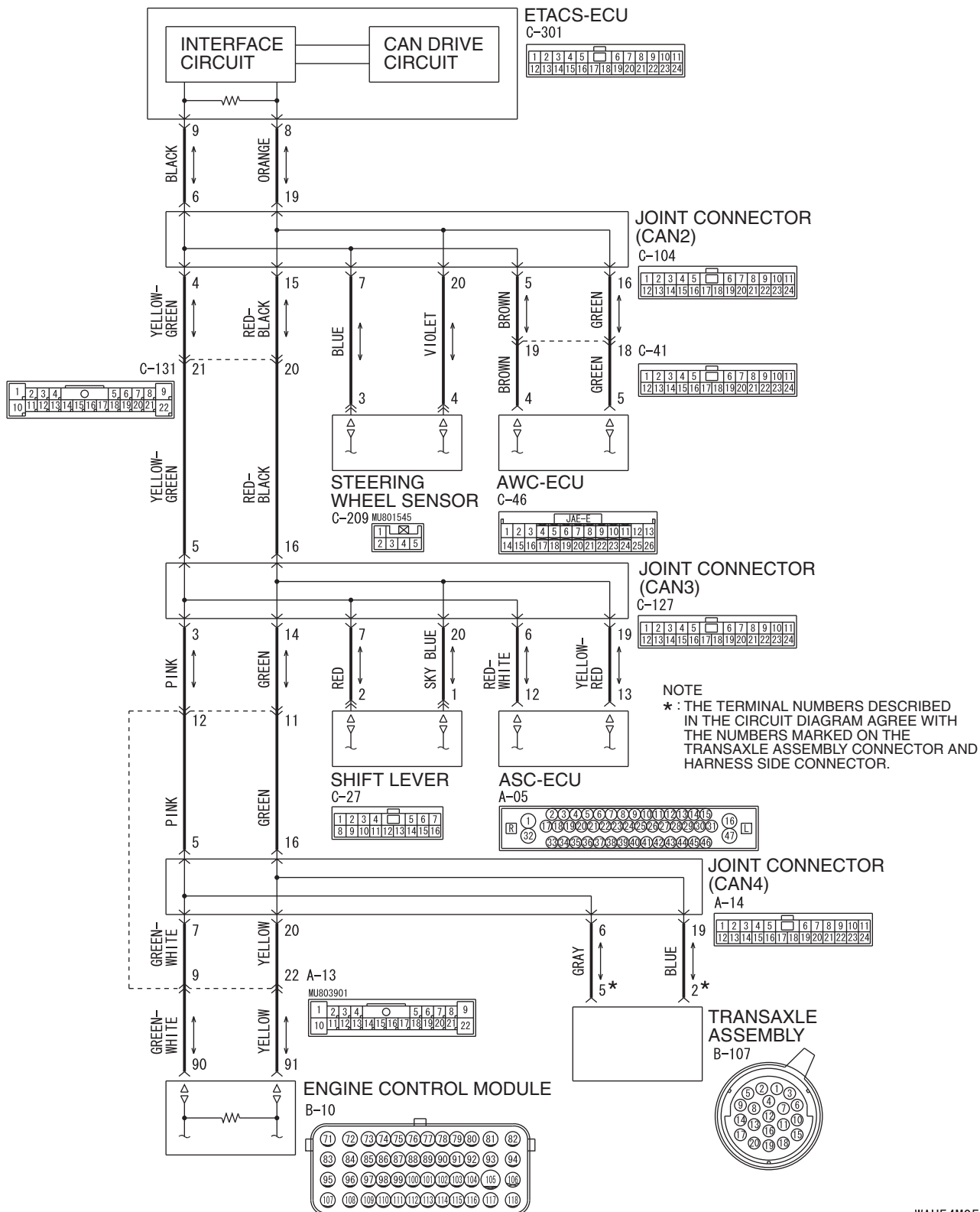

Connector: A-05

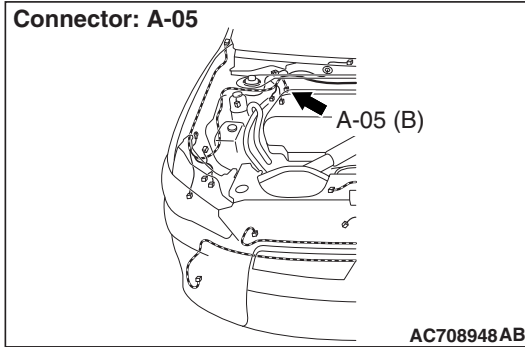

Connector: C-127

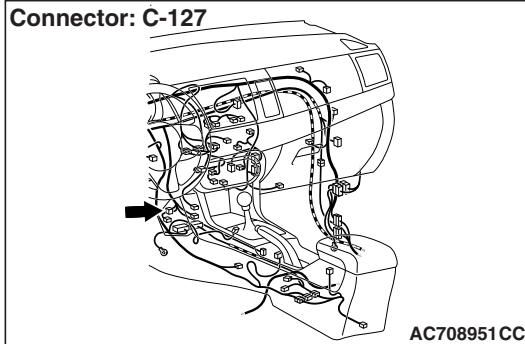
**FUNCTION**

If the scan tool MB991958 cannot communicate with the ASC-ECU, this diagnosis result will be set.

**TROUBLE JUDGMENT CONDITIONS**

If a communication flag is not set for the ASC-ECU, the ETACS-ECU determines that there is a failure.

**TROUBLESHOOTING HINTS**

- Malfunction of the connector [joint connector (CAN3) or ASC-ECU connector improperly connected]
- Malfunction of the wiring harness [open circuit between the ASC-ECU and the joint connector (CAN3), power supply circuit to the ASC-ECU]
- Malfunction of the ASC-ECU

**DIAGNOSIS****Required Special Tools:**

- MB991223: Harness Set
- MB992006: Extra Fine Probe
- MB991997: ASC Check Harness

**STEP 1. Check joint connector (CAN3) C-127 and ASC-ECU connector A-05 for loose, corroded or damaged terminals, or terminals pushed back in the connector.**

**⚠ CAUTION**

The strand end of the twisted wire should be within 10 cm (4 inches) from the connector. For details refer to [P.54C-7](#).

**Q: Are joint connector (CAN3) C-127 and ASC-ECU connector A-05 in good condition?**

**YES :** Go to Step 2.

**NO :** Repair the damaged parts.

**STEP 2. Check the wiring harness between joint connector (CAN3) C-127 and ASC-ECU connector A-05 for open circuit.**

**⚠ CAUTION**

**Strictly observe the specified wiring harness repair procedure. For details refer to P.54C-7.**

- (1) Disconnect joint connector (CAN3) C-127 and ASC-ECU connector A-05, and check the wiring harness.
- (2) Check the wiring harness between joint connector (CAN3) C-127 (terminal 6) and ASC-ECU connector A-05 (terminal 12)

**OK: Continuity exists (2 Ω or less)**

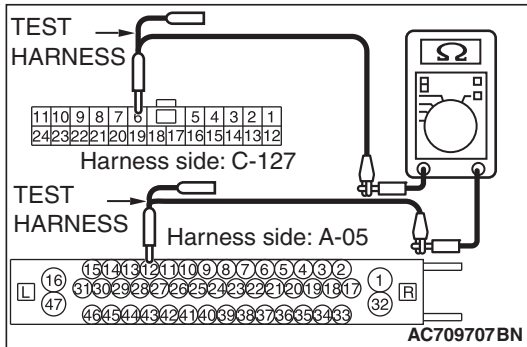

- (3) Check the wiring harness between joint connector (CAN3) C-127 (terminal 19) and ASC-ECU connector A-05 (terminal 13)

**OK: Continuity exists (2 Ω or less)**

**Q: Is the wiring harness between joint connector (CAN3) C-127 and ASC-ECU connector A-05 in good condition?**

- YES :** Check the power supply circuit of the ASC-ECU. Refer to GROUP 35C, Troubleshooting P.35C-258.
- NO :** Repair the wiring harness between joint connector (CAN3) C-127 and ASC-ECU connector A-05.

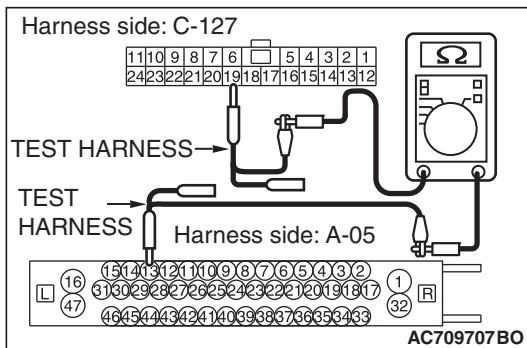

DIAGNOSTIC ITEM 10: Diagnose when the scan tool cannot receive the data sent by ECM.

**CAUTION**

When servicing a CAN bus line, ground yourself by touching a metal object such as an unpainted water pipe. If you fail to do so, a component connected to the CAN bus line may be damaged.

CAN-C Communication Circuit <M/T>

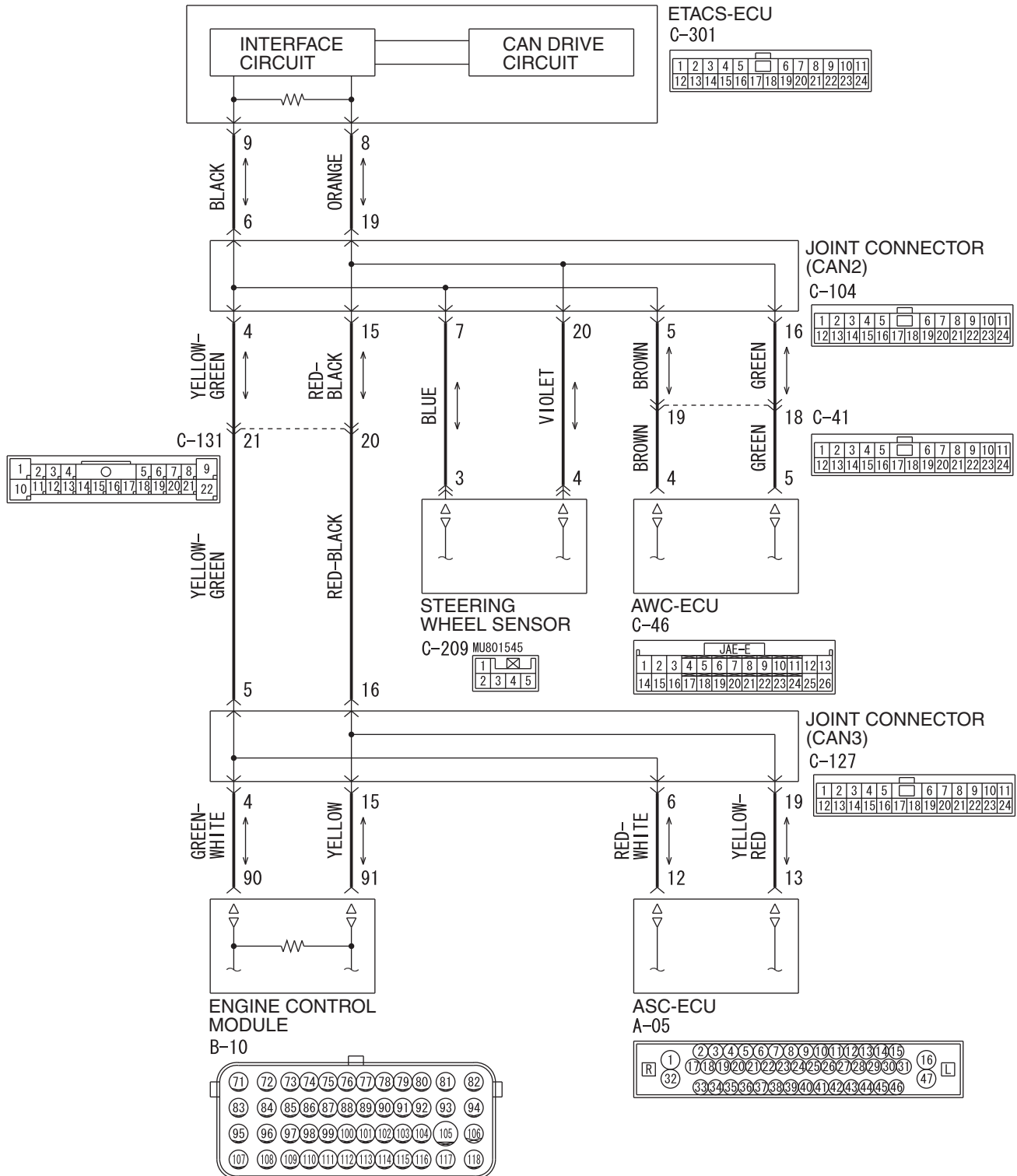

CAN-C Communication Circuit <TC-SST>

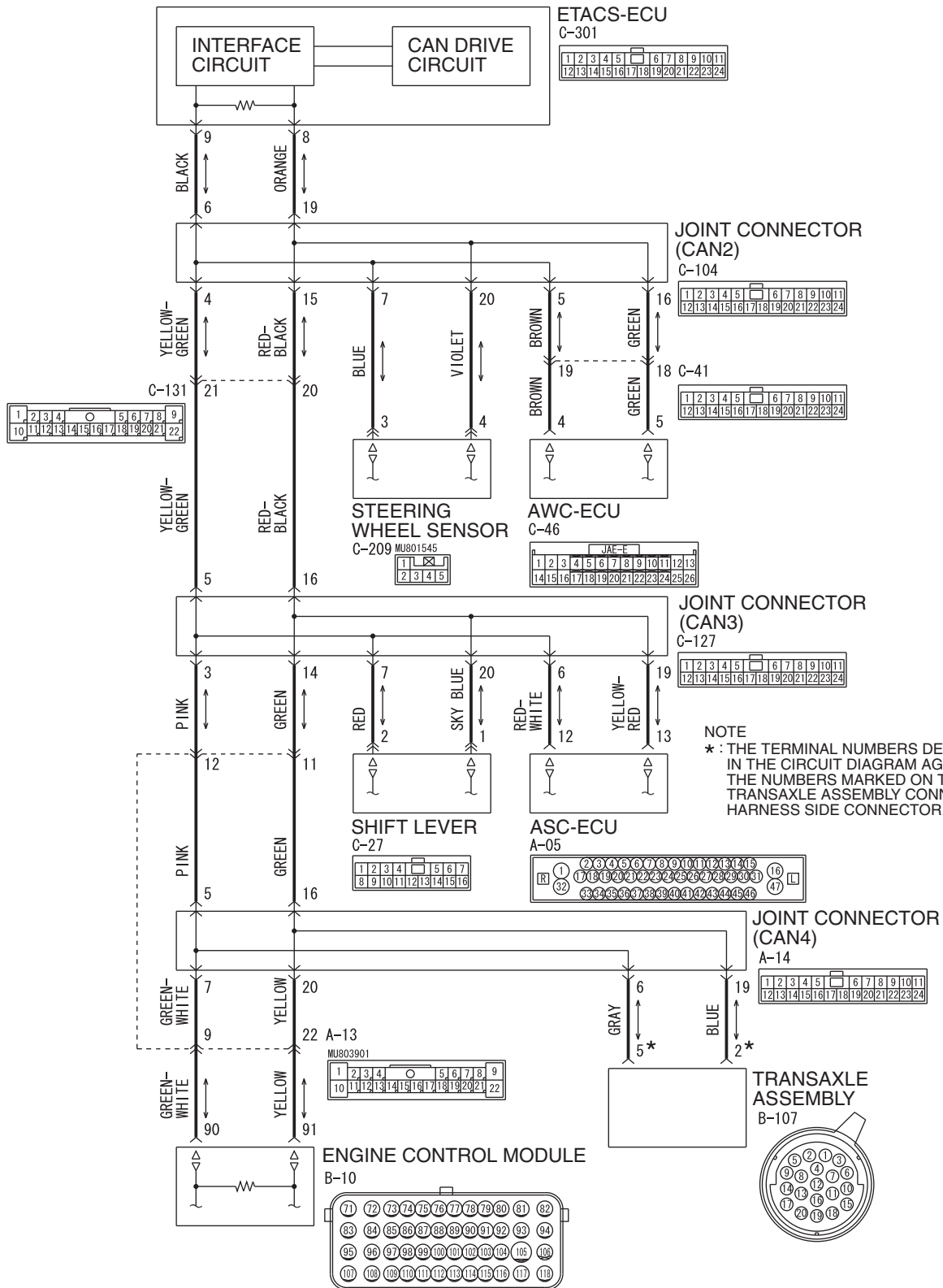

NOTE  
\* : THE TERMINAL NUMBERS DESCRIBED IN THE CIRCUIT DIAGRAM AGREE WITH THE NUMBERS MARKED ON THE TRANSAXLE ASSEMBLY CONNECTOR AND HARNESS SIDE CONNECTOR.

Connectors: A-13, A-14

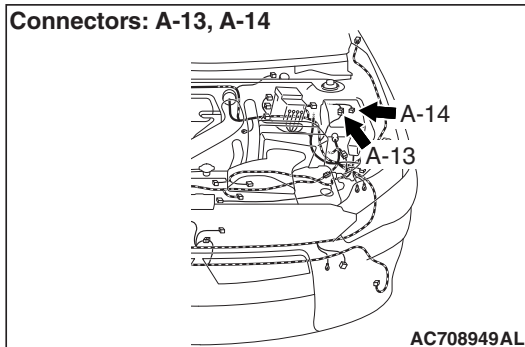

Connector: C-127

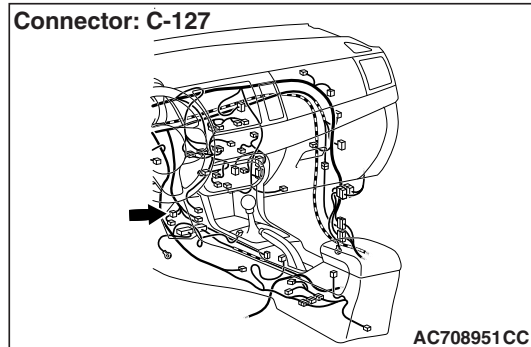

Connector: B-10

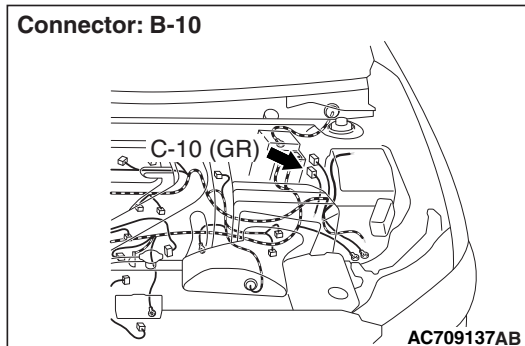
**FUNCTION**

If the scan tool MB991958 cannot communicate with the ECM, this diagnosis result will be set.

**TROUBLE JUDGMENT CONDITIONS**

If a communication flag is not set for the ECM, the ETACS-ECU determines that there is a failure.

**TROUBLESHOOTING HINTS**

- Malfunction of the connector [joint connector (CAN3) <M/T>, joint connector (CAN4) <TC-SST>, ECM connector or intermediate connector <TC-SST> improperly connected]
- Malfunction of the wiring harness [open circuit between the ECM connector and the joint connector (CAN3) <M/T> or the joint connector (CAN4) <TC-SST>, power supply circuit to the ECM]
- Malfunction of the ECM

**DIAGNOSIS****Required Special Tools:**

- MB991223: Harness Set
- MB992006: Extra Fine Probe
- MB992110: Power plant ECU check harness

**STEP 1.** Check joint connector (CAN3) C-127 <M/T>, joint connector (CAN4) A-14 <TC-SST>, ECM connector B-10 and intermediate connector A-13 <TC-SST> for loose, corroded or damaged terminals, or terminals pushed back in the connector.

**CAUTION**

The strand end of the twisted wire should be within 10 cm (4 inches) from the connector. For details refer to [P.54C-7](#).

**Q:** Are joint connector (CAN3) C-127 <M/T>, joint connector (CAN4) A-14 <M/T>, ECM connector B-10 and intermediate connector A-13 <TC-SST> in good condition?

**YES :** Go to Step 2.

**NO :** Repair the damaged parts.

**STEP 2. Check the wiring harness between joint connector (CAN3) C-127 <M/T> or joint connector (CAN4) A-14 <TC-SST> and ECM connector B-10.**

**⚠ CAUTION**

**Strictly observe the specified wiring harness repair procedure. For details refer to P.54C-7.**

- (1) Disconnect joint connector (CAN3) C-127 and ECM connector B-10, and check the wiring harness.
- (2) Check the wiring harness between joint connector (CAN3) C-127 (terminal 4) and ECM connector B-10 (terminal 90) <M/T>

**OK: Continuity exists (2 Ω or less)**

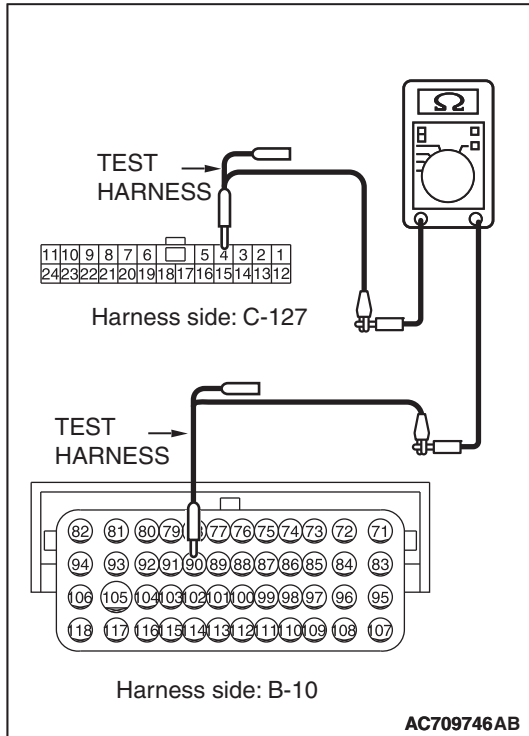

- (3) Check the wiring harness between joint connector (CAN3) C-127 (terminal 15) and ECM connector B-10 (terminal 91) <M/T>

**OK: Continuity exists (2 Ω or less)**

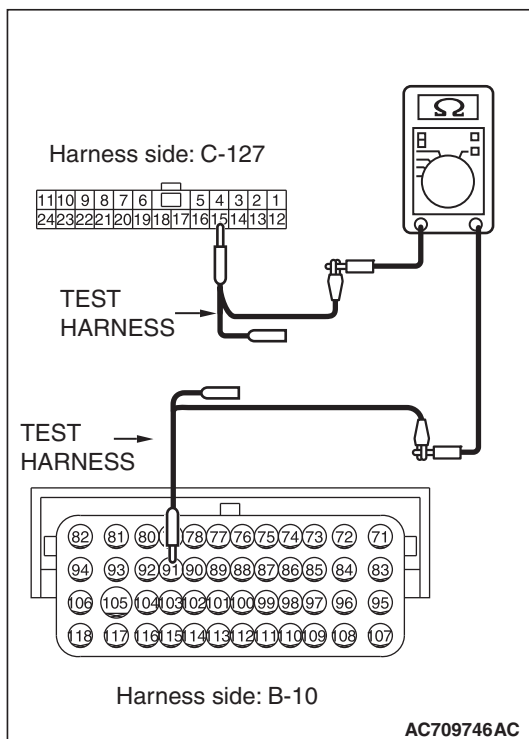

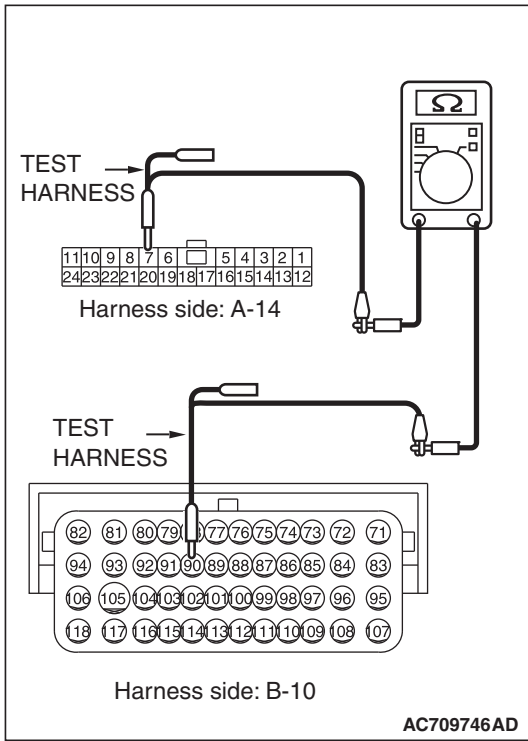

- (4) Check the wiring harness between joint connector (CAN4) A-14 (terminal 7) and ECM connector B-10 (terminal 90) <TC-SST>

**OK: Continuity exists (2 Ω or less)**

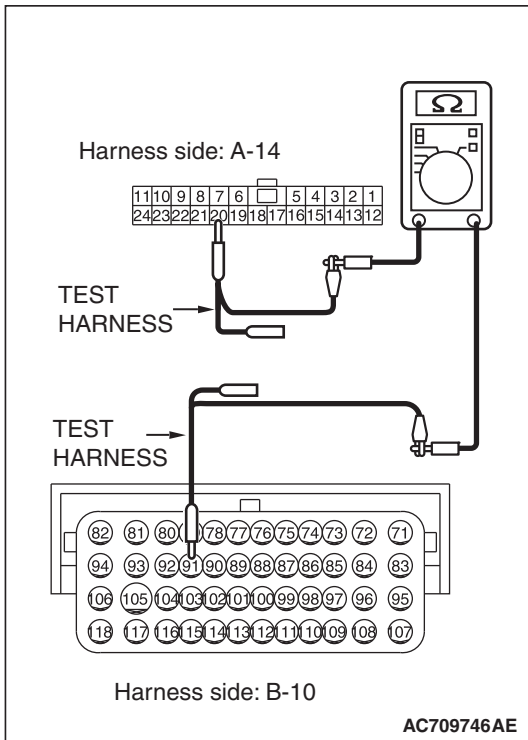

- (5) Check the wiring harness between joint connector (CAN4) A-14 (terminal 20) and ECM connector B-10 (terminal 91) <TC-SST>

**OK: Continuity exists (2 Ω or less)**

**Q: Is the wiring harness between joint connector (CAN3) C-127 <M/T> or joint connector (CAN4) A-14 <TC-SST> and ECM connector B-10 in good condition?**

**YES :** Check the power supply circuit of the ECM. Refer to GROUP 13A, MFI Diagnosis .

**NO :** Repair the wiring harness between joint connector (CAN3) C-127 <M/T> or joint connector (CAN4) A-14 <TC-SST> and ECM connector B-10.



**DIAGNOSTIC ITEM 11: Diagnose when the scan tool cannot receive the data sent by TC-SST-ECU.  
<TC-SST>**

**CAUTION**

When servicing a CAN bus line, ground yourself by touching a metal object such as an unpainted water pipe. If you fail to do so, a component connected to the CAN bus line may be damaged.

CAN-C Communication Circuit <TC-SST>

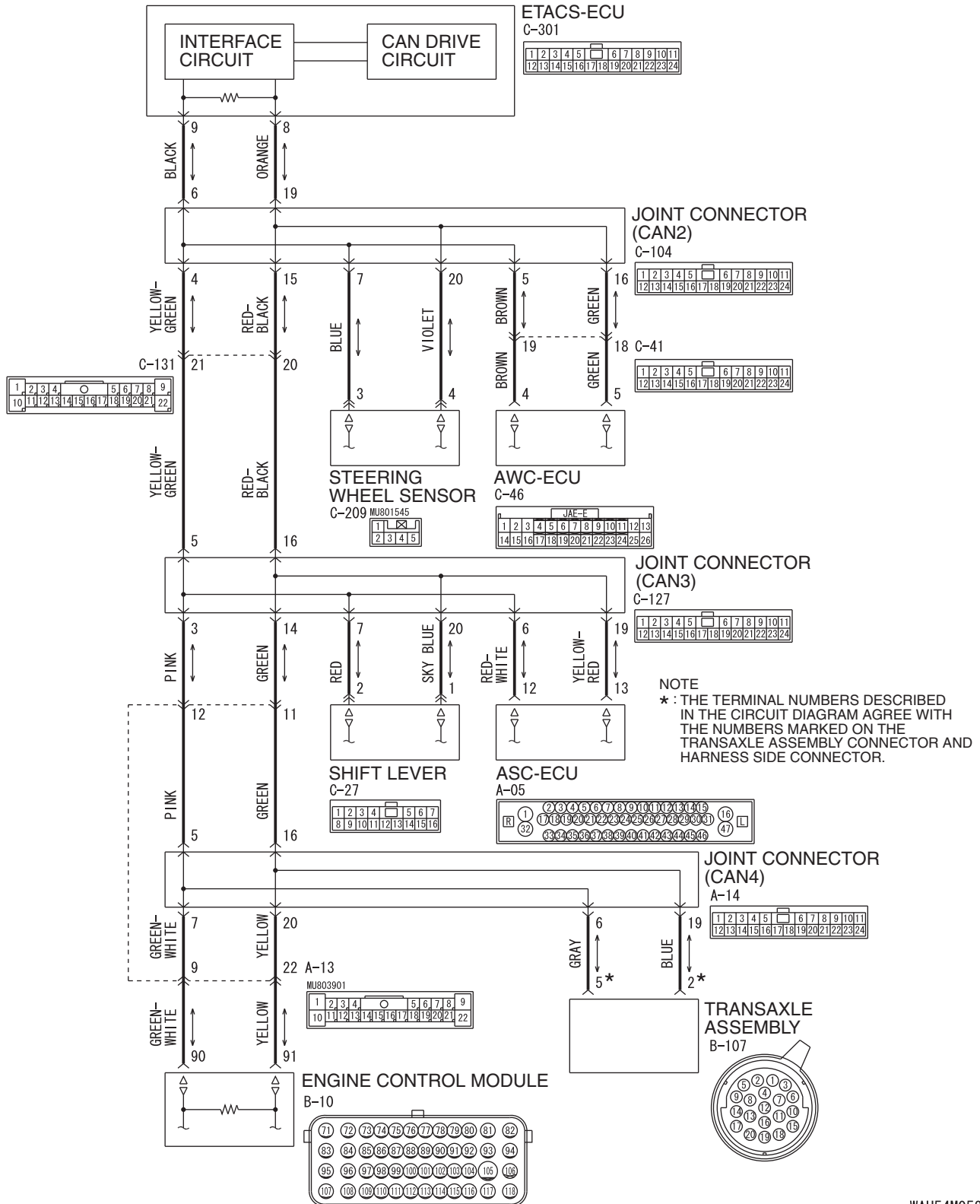

Connector: A-14

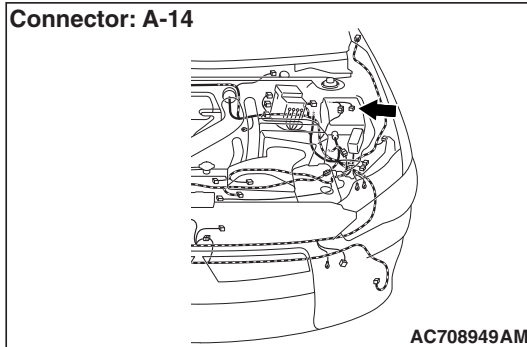

Connector: B-107

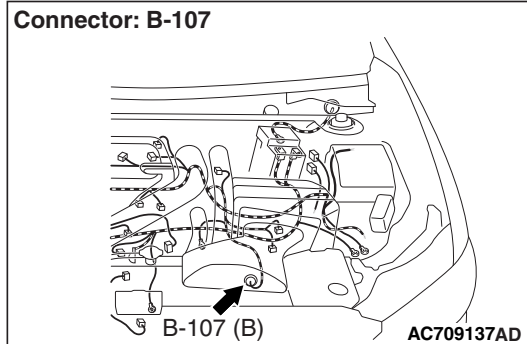
**FUNCTION**

If the scan tool MB991958 cannot communicate with the TC-SST-ECU, this diagnosis result will be set.

**TROUBLE JUDGMENT CONDITIONS**

If a communication flag is not set for the TC-SST-ECU, the ETACS-ECU determines that there is a failure.

**TROUBLESHOOTING HINTS**

- Malfunction of the connector [joint connector (CAN4), transaxle assembly connector improperly connected]
- Malfunction of the wiring harness [open circuit between the transaxle assembly connector and the joint connector (CAN4), power supply circuit to the transaxle assembly]
- Malfunction of the TC-SST-ECU

**DIAGNOSIS****Required Special Tools:**

- MB991223: Harness Set
- MB992006: Extra Fine Probe

**STEP 1. Check joint connector (CAN4) A-14 and transaxle assembly connector B-107 for loose, corroded or damaged terminals, or terminals pushed back in the connector.**

**⚠ CAUTION**

The strand end of the twisted wire should be within 10 cm (4 inches) from the connector. For details refer to [P.54C-7](#).

**Q: Are joint connector (CAN4) A-14 and transaxle assembly connector B-107 in good condition?**

**YES :** Go to Step 2.

**NO :** Repair the damaged parts.

**STEP 2. Check the wiring harness between joint connector (CAN4) A-14 and transaxle assembly connector B-107 for open circuit.**

**⚠ CAUTION**

**Strictly observe the specified wiring harness repair procedure. For details refer to P.54C-7.**

- (1) Disconnect joint connector (CAN4) A-14 and transaxle assembly B-107, and check the wiring harness.
- (2) Check the wiring harness between joint connector (CAN4) A-14 (terminal 6) and transaxle assembly connector B-107 (terminal 5)

**OK: Continuity exists (2 Ω or less)**

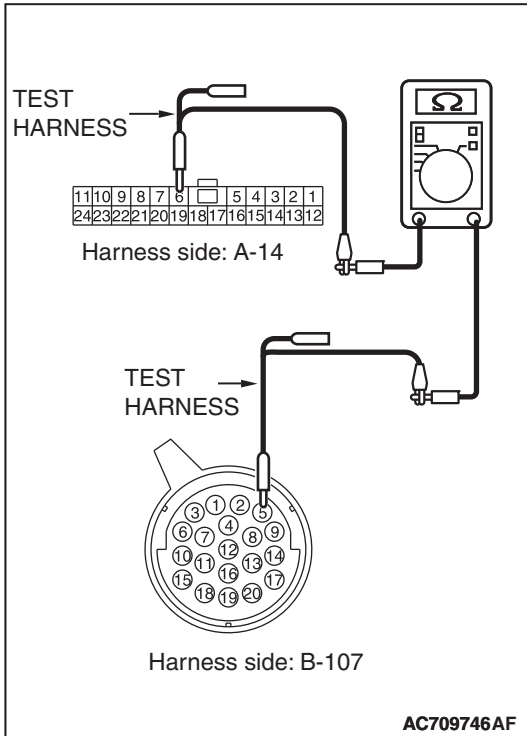

- (3) Check the wiring harness between joint connector (CAN4) A-14 (terminal 19) and transaxle assembly connector B-107 (terminal 2)

**OK: Continuity exists (2 Ω or less)**

**Q: Is the wiring harness between joint connector (CAN4) A-14 and transaxle assembly connector B-107 in good condition?**

**YES :** Check the power supply circuit of the transaxle assembly. Refer to GROUP 22C, TC-SST –Diagnosis P.22C-15.

**NO :** Repair the wiring harness between joint connector (CAN4) A-14 and transaxle assembly connector B-107.

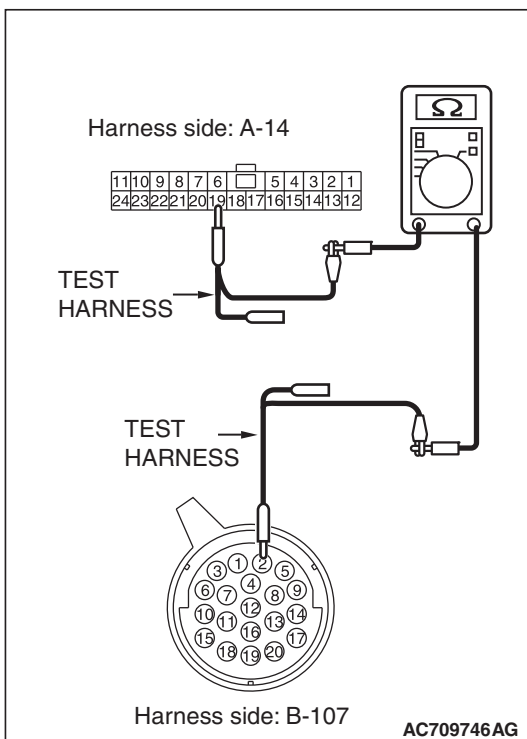

DIAGNOSTIC ITEM 12: Diagnose the lines between the ETACS-ECU and joint connector (CAN2).

**CAUTION**

When servicing a CAN bus line, ground yourself by touching a metal object such as an unpainted water pipe. If you fail to do so, a component connected to the CAN bus line may be damaged.

CAN-C Communication Circuit <M/T>

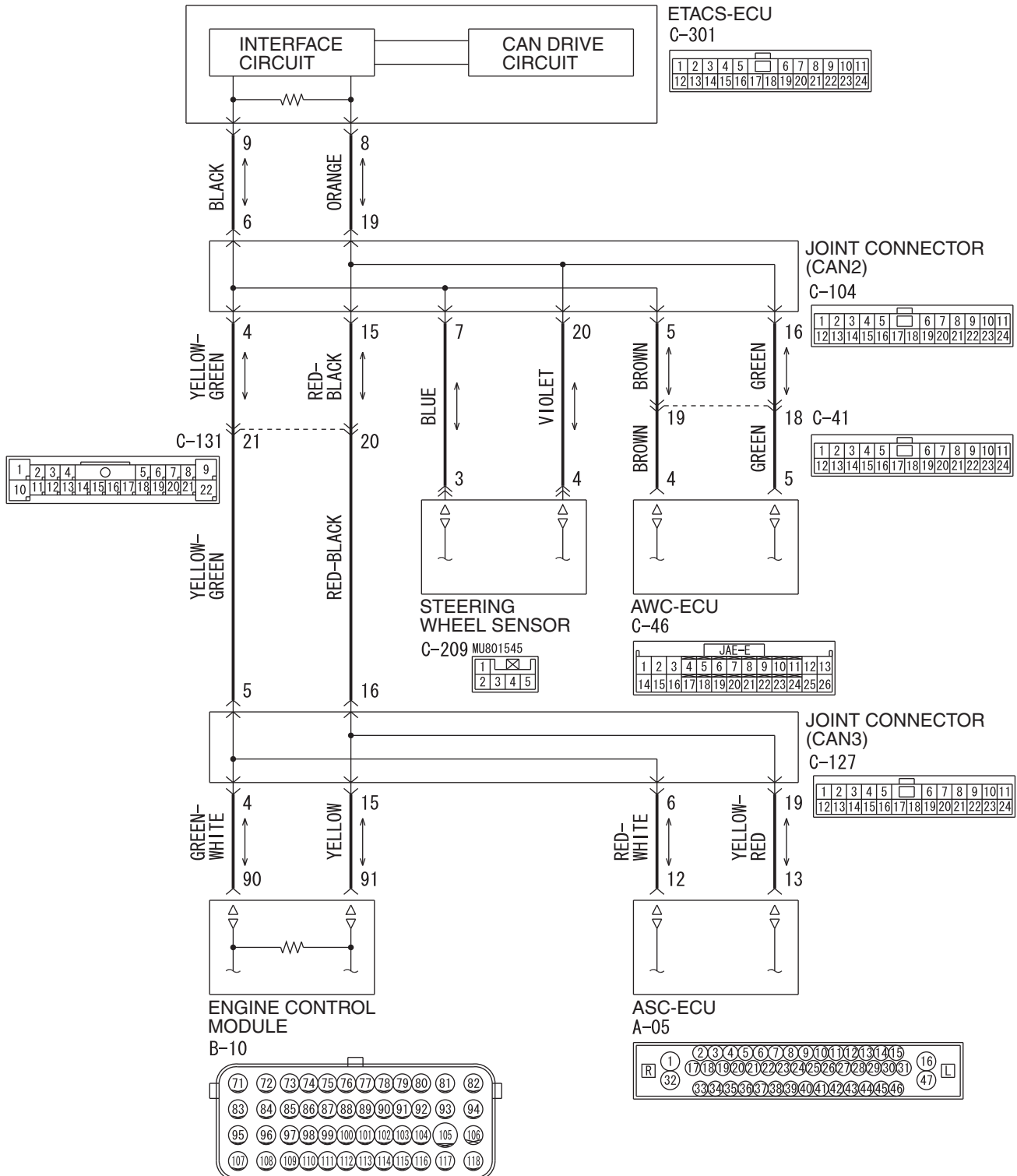

**CAN-C Communication Circuit <TC-SST>**

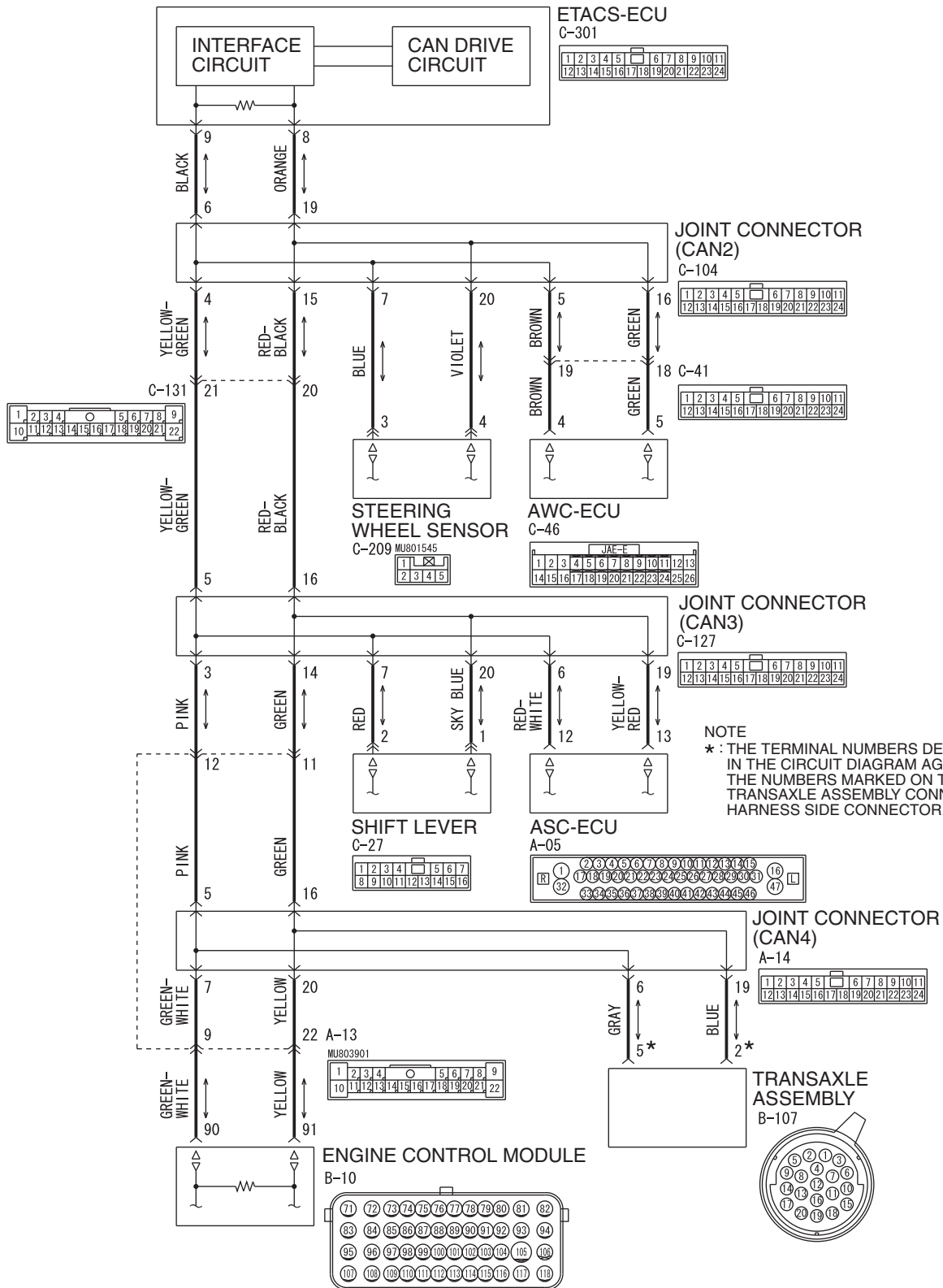

Connector: C-104

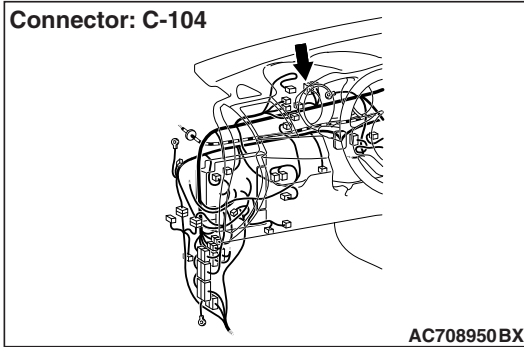

AC708950BX

**FUNCTION**

If a failure is present in the wiring harness between the ETACS-ECU connector and the joint connector (CAN2), this diagnosis result will be set.

**TROUBLE JUDGMENT CONDITIONS**

If a communication flag is not set for some of the ECUs on the CAN-C line, the ETACS-ECU determines that there is a failure.

**TROUBLESHOOTING HINTS**

- Malfunction of the connector [joint connector (CAN2) or ETACS-ECU connector improperly connected]
- Malfunction of the wiring harness [open circuit between the ETACS-ECU connector and the joint connector (CAN2), power supply circuit to the ECM]
- Malfunction of the ETACS-ECU

Connector: C-301

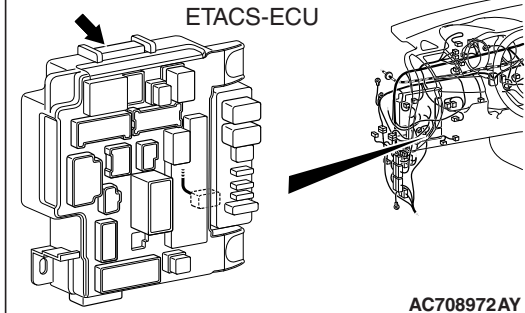

AC708972AY

**DIAGNOSIS****Required Special Tools:**

- MB991223: Harness Set
- MB992006: Extra Fine Probe

**STEP 1. Check joint connector (CAN2) C-104 and ETACS-ECU connector C-301 for loose, corroded or damaged terminals, or terminals pushed back in the connector.**

**⚠ CAUTION**

The strand end of the twisted wire should be within 10 cm (4 inches) from the connector. For details refer to [P.54C-7](#).

**Q: Are joint connector (CAN2) C-104 and ETACS-ECU connector C-301 in good condition?**

**YES :** Go to Step 2.

**NO :** Repair the damaged parts.

**STEP 2. Check the wiring harness between joint connector (CAN2) C-104 and ETACS-ECU connector C-301 for open circuit.**

**⚠ CAUTION**

**Strictly observe the specified wiring harness repair procedure. For details refer to P.54C-7.**

- (1) Disconnect joint connector (CAN2) C-104 and ETACS-ECU connector C-301, and check the wiring harness.
- (2) Check the wiring harness between joint connector (CAN2) C-104 (terminal 6) and ETACS-ECU connector C-301 (terminal 9)

**OK: Continuity exists (2 Ω or less)**

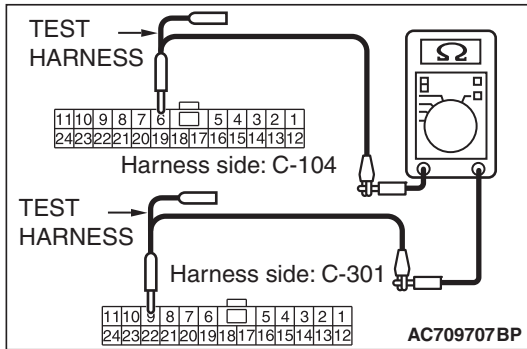

- (3) Check the wiring harness between joint connector (CAN2) C-104 (terminal 19) and ETACS-ECU connector C-301 (terminal 8)

**OK: Continuity exists (2 Ω or less)**

**Q: Is the wiring harness between joint connector (CAN2) C-104 and ETACS-ECU connector C-301 in good condition?**

**YES :** Go to Step 3.

**NO :** Repair the wiring harness between joint connector (CAN2) C-104 and ETACS-ECU connector C-301.

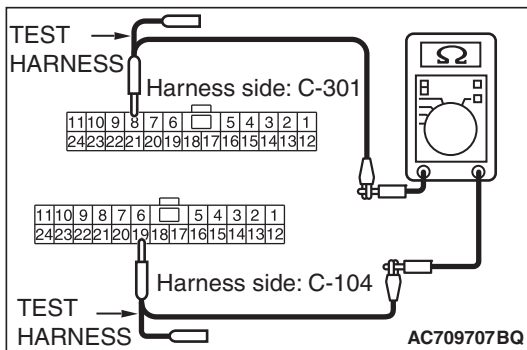

**STEP 3. Using scan tool MB991958, diagnose the CAN bus line.**

**⚠ CAUTION**

To prevent damage to scan tool MB991958, always turn the ignition switch to the "LOCK" (OFF) position before connecting or disconnecting scan tool MB991958.

- (1) Connect scan tool MB991958 to the data link connector.
- (2) Turn the ignition switch to the "ON" position.

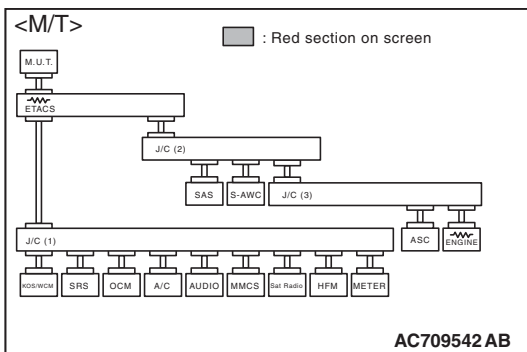
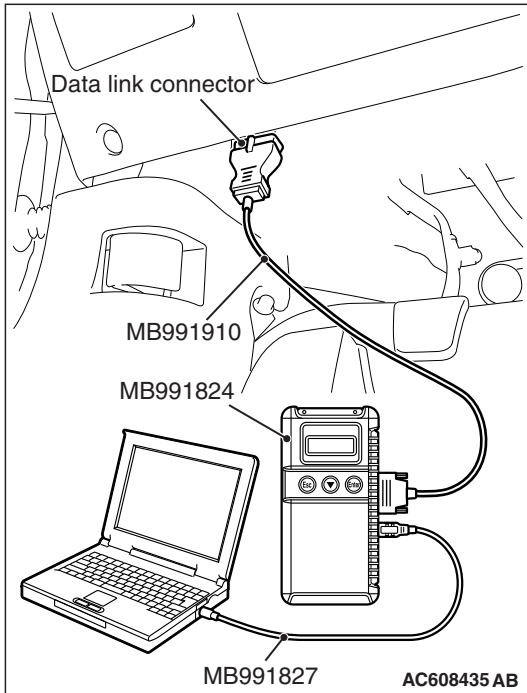

- (3) Diagnose CAN bus lines, and check if the scan tool screen is as shown in the illustration.

**Q: Does the scan tool screen correspond to the illustration?**

**YES :** The trouble can be an intermittent malfunction (Refer to GROUP 00, How to use Troubleshooting/inspection Service Points –How to Cope with Intermittent Malfunction P.00-15).

**NO :** Replace the ETACS-ECU.

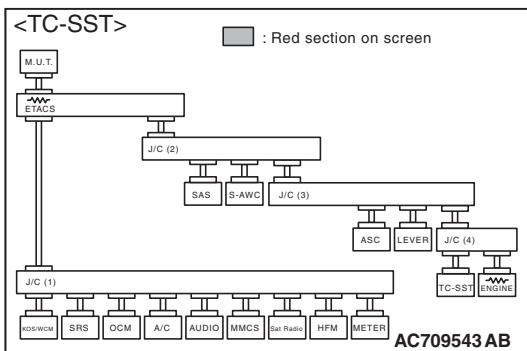



**DIAGNOSTIC ITEM 13: Diagnose the lines between joint connector (CAN2) and joint connector (CAN3).**

**CAUTION**

When servicing a CAN bus line, ground yourself by touching a metal object such as an unpainted water pipe. If you fail to do so, a component connected to the CAN bus line may be damaged.

CAN-C Communication Circuit <M/T>

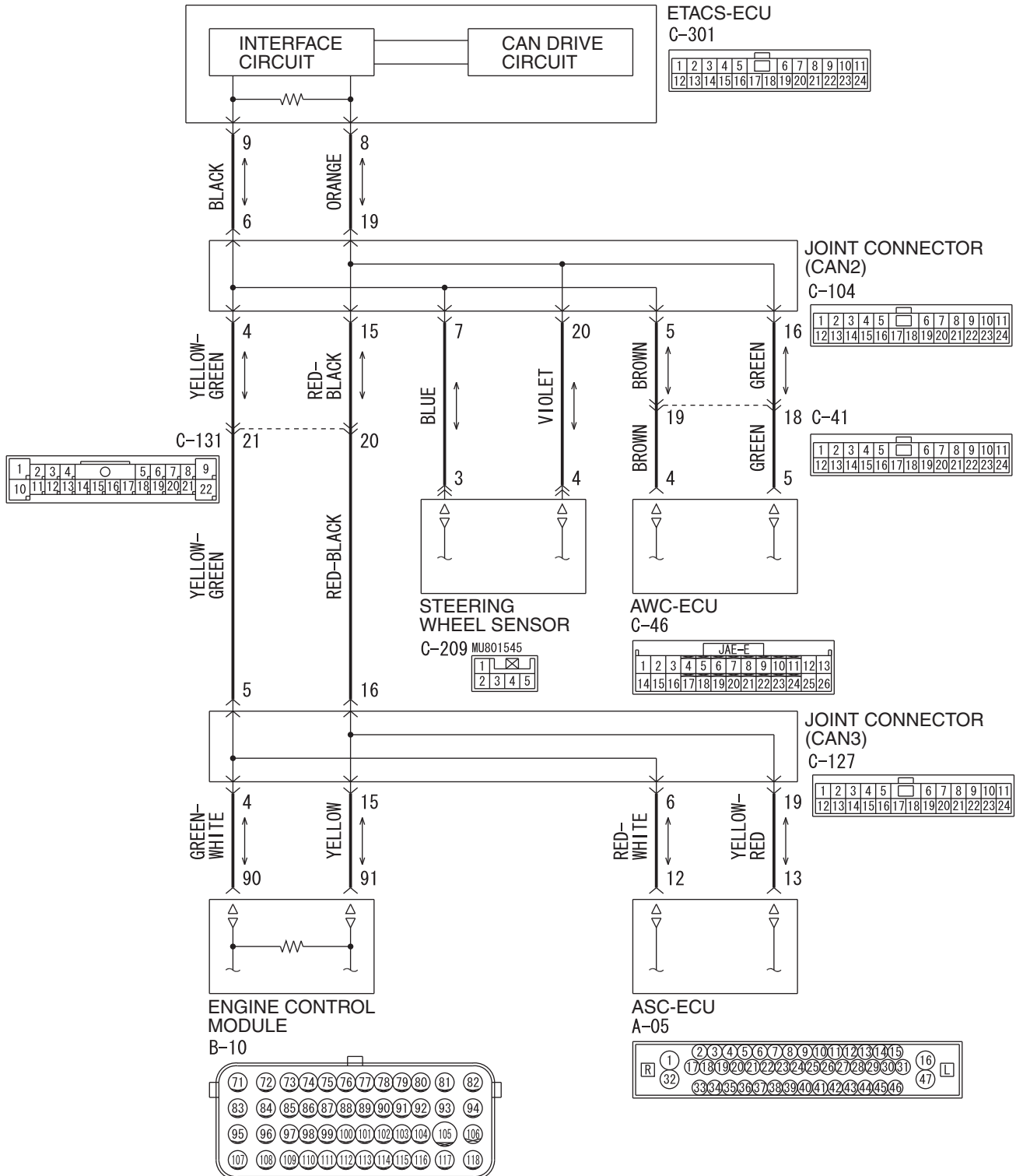

CAN-C Communication Circuit <TC-SST>

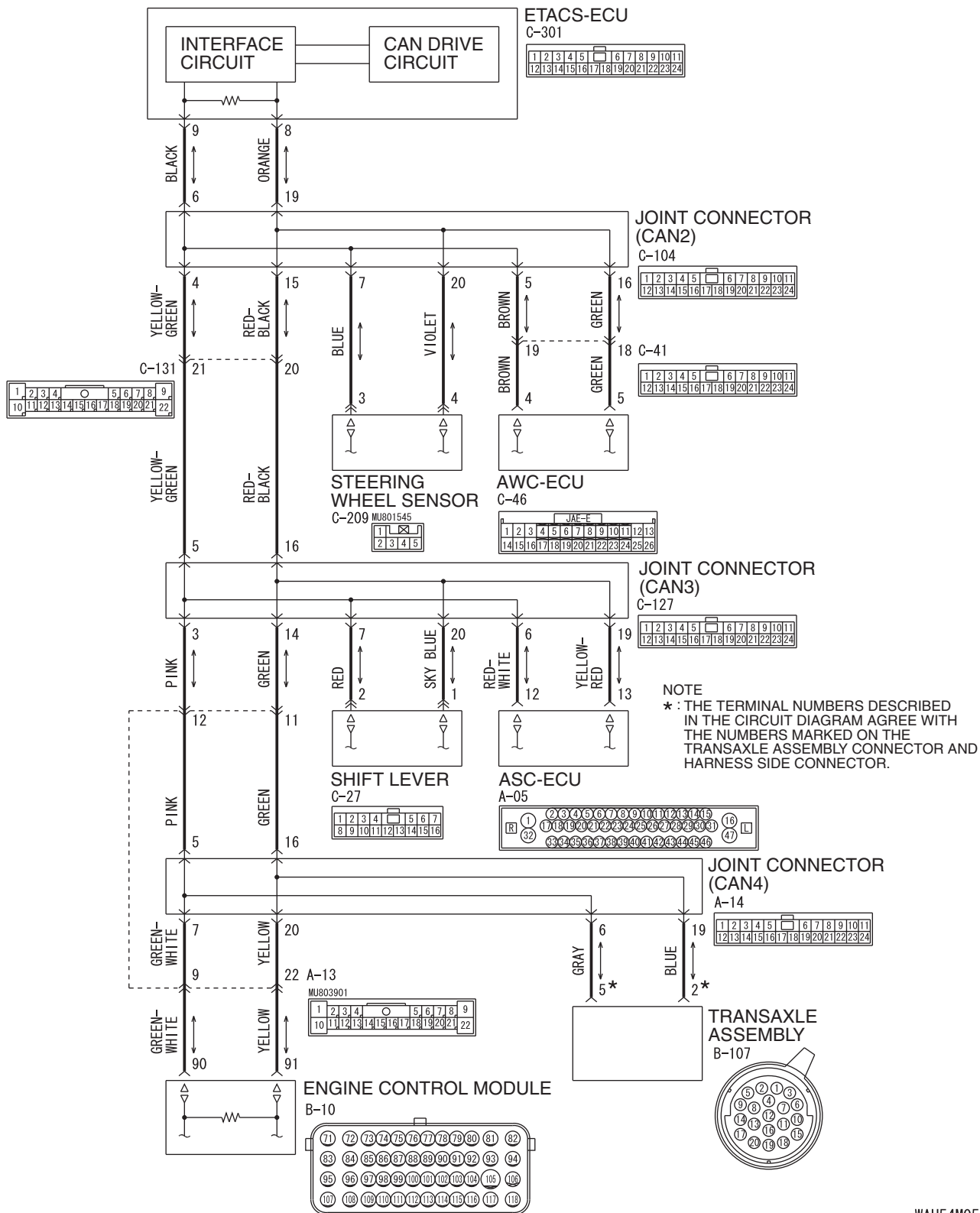

WAH54M052A

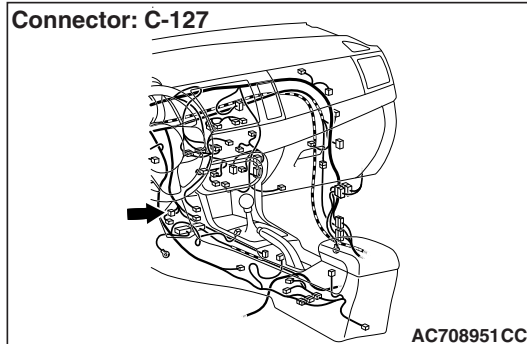
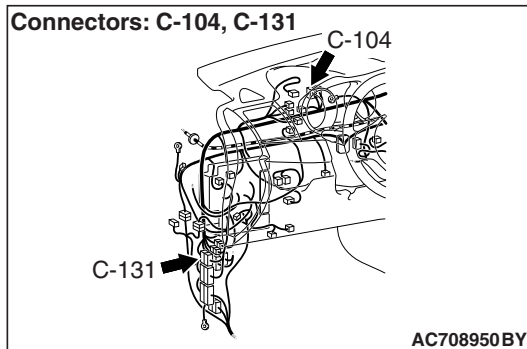

## FUNCTION

If a failure is present in the wiring harness between the joint connector (CAN2) and the joint connector (CAN3), this diagnosis result will be set.

## TROUBLE JUDGMENT CONDITIONS

If a communication flag is not set for some of the ECUs on the CAN-C line, the ETACS-ECU determines that there is a failure.

## TROUBLESHOOTING HINTS

- Malfunction of the connector [joint connector (CAN2), joint connector (CAN3) or intermediate connector failed]
- Malfunction of the wiring harness [open circuit between joint connector (CAN2) and joint connector (CAN3)]

## DIAGNOSIS

### Required Special Tools:

- MB991223: Harness Set
- MB992006: Extra Fine Probe

**STEP 1. Check joint connector (CAN2) C-104, joint connector (CAN3) C-127 and intermediate connector C-131 for loose, corroded or damaged terminals, or terminals pushed back in the connector.**

### **⚠ CAUTION**

The strand end of the twisted wire should be within 10 cm (4 inches) from the connector. For details refer to [P.54C-7](#).

**Q: Are joint connector (CAN2) C-104, joint connector (CAN3) C-127 and intermediate connector C-131 in good condition?**

**YES :** Go to Step 2.

**NO :** Repair the damaged parts.

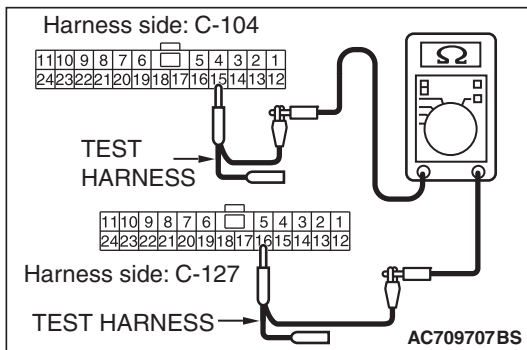
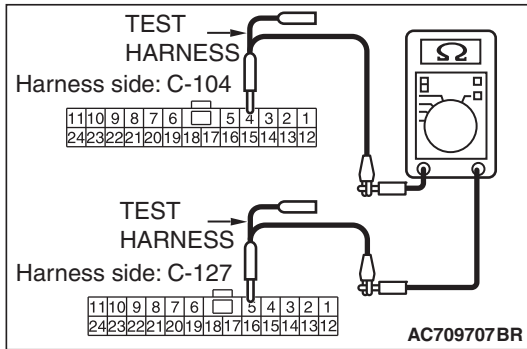

**STEP 2. Check the wiring harness between joint connector (CAN2) C-104 and joint connector (CAN3) C-127 for open circuit.**

**⚠ CAUTION**

**Strictly observe the specified wiring harness repair procedure. For details refer to P.54C-7.**

- (1) Disconnect joint connector (CAN2) C-104 and joint connector (CAN3) C-127, and check the wiring harness.
- (2) Check the wiring harness between joint connector (CAN2) C-104 (terminal 4) and joint connector (CAN3) C-127 (terminal 5)

**OK: Continuity exists (2 Ω or less)**

- (3) Check the wiring harness between joint connector (CAN2) C-104 (terminal 15) and joint connector (CAN3) C-127 (terminal 16)

**OK: Continuity exists (2 Ω or less)**

**Q: Is the wiring harness between joint connector (CAN2) C-104 and joint connector (CAN3) C-127 in good condition?**

**YES :** The trouble can be an intermittent malfunction (Refer to GROUP 00, How to use

Troubleshooting/inspection Service Points –How to Cope with Intermittent Malfunction P.00-15).

**NO :** Repair the wiring harness between joint connector (CAN2) C-104 and joint connector (CAN3) C-127.

**DIAGNOSTIC ITEM 14: Diagnose the lines between joint connector (CAN3) and joint connector (CAN4). <TC-SST>**

**CAUTION**

When servicing a CAN bus line, ground yourself by touching a metal object such as an unpainted water pipe. If you fail to do so, a component connected to the CAN bus line may be damaged.

CAN-C Communication Circuit <TC-SST>

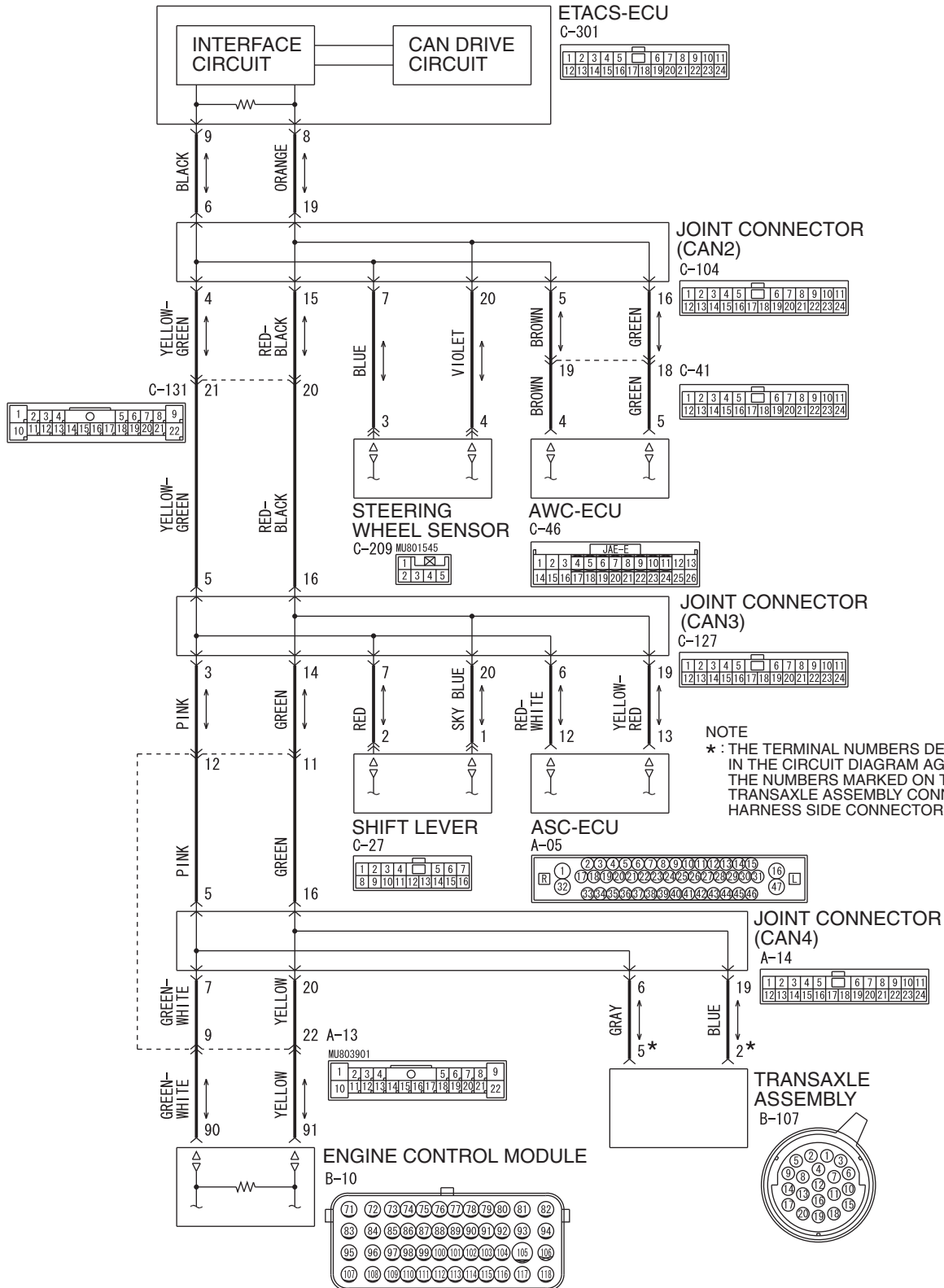

Connectors: A-13, A-14

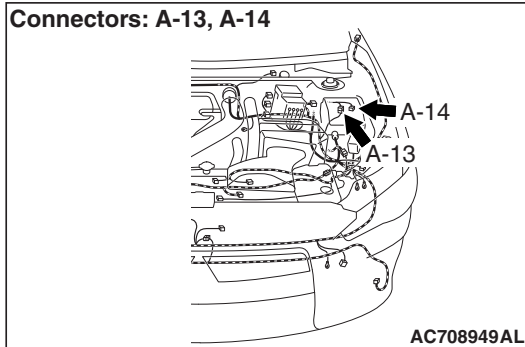

Connector: C-127

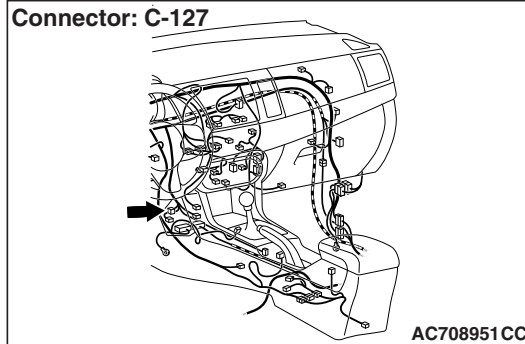
**FUNCTION**

If a failure is present in the wiring harness between the joint connector (CAN3) and the joint connector (CAN4), this diagnosis result will be set.

**TROUBLE JUDGMENT CONDITIONS**

If a communication flag is not set for some of the ECUs on the CAN-C line, the ETACS-ECU determines that there is a failure.

**TROUBLESHOOTING HINTS**

- Malfunction of the connector [joint connector (CAN3), joint connector (CAN4) or intermediate connector failed]
- Malfunction of the wiring harness [open circuit between joint connector (CAN3) and joint connector (CAN4)]

**DIAGNOSIS****Required Special Tools:**

- MB991223: Harness Set
- MB992006: Extra Fine Probe

**STEP 1. Check joint connector (CAN3) C-127, joint connector (CAN4) A-14 and intermediate connector A-13 for loose, corroded or damaged terminals, or terminals pushed back in the connector.**

**⚠ CAUTION**

The strand end of the twisted wire should be within 10 cm (4 inches) from the connector. For details refer to [P.54C-7](#).

**Q: Are joint connector (CAN3) C-127, joint connector (CAN4) A-14 and intermediate connector A-13 in good condition?**

**YES :** Go to Step 2.

**NO :** Repair the damaged parts.

**STEP 2. Check the wiring harness between joint connector (CAN3) C-127 and joint connector (CAN4) A-14 for open circuit.**

**⚠ CAUTION**

**Strictly observe the specified wiring harness repair procedure. For details refer to P.54C-7.**

- (1) Disconnect joint connector (CAN3) C-127 and joint connector (CAN4) A-14, and check the wiring harness.
- (2) Check the wiring harness between joint connector (CAN3) C-127 (terminal 3) and joint connector (CAN4) A-14 (terminal 5)

**OK: Continuity exists (2 Ω or less)**

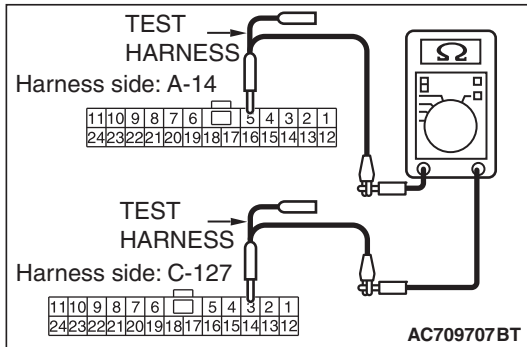

- (3) Check the wiring harness between joint connector (CAN3) C-127 (terminal 14) and joint connector (CAN4) A-14 (terminal 16)

**OK: Continuity exists (2 Ω or less)**

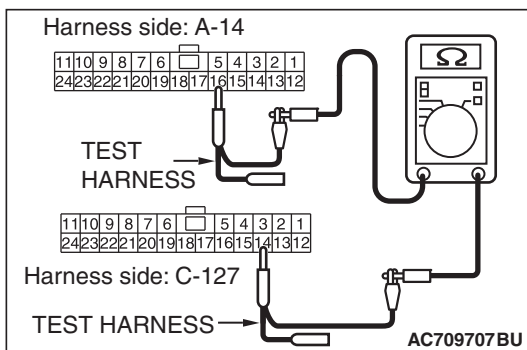

**Q: Is the wiring harness between joint connector (CAN3) C-127 and joint connector (CAN4) A-14 in good condition?**

**YES :** The trouble can be an intermittent malfunction (Refer to GROUP 00, How to use

Troubleshooting/inspection Service Points –How to Cope with Intermittent Malfunction P.00-15).

**NO :** Repair the wiring harness between joint connector (CAN3) C-127 and joint connector (CAN4) A-14.

DIAGNOSTIC ITEM 15: Diagnose when the scan tool cannot receive the data sent by KOS-ECU.

**CAUTION**

When servicing a CAN bus line, ground yourself by touching a metal object such as an unpainted water pipe. If you fail to do so, a component connected to the CAN bus line may be damaged.

CAN-B Communication Circuit

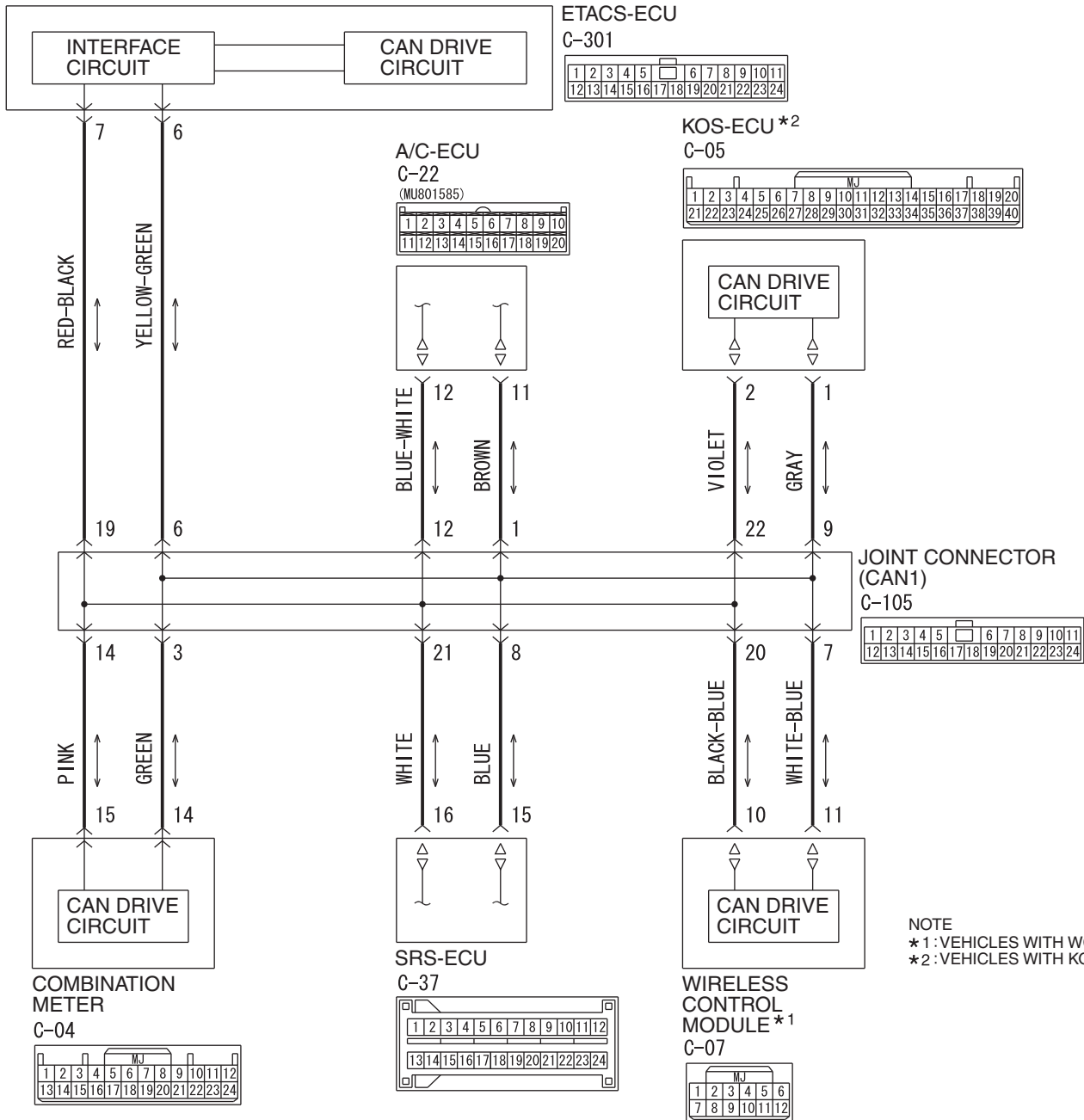



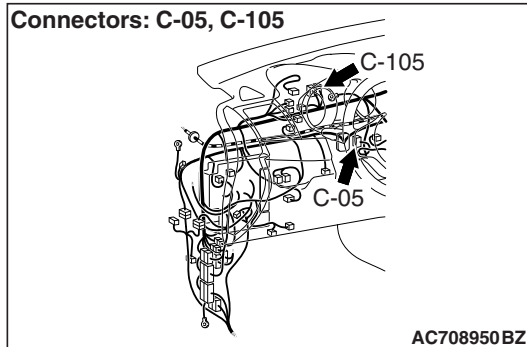

## FUNCTION

If the scan tool MB991958 cannot communicate with the KOS-ECU, this diagnosis result will be set.

## TROUBLE JUDGMENT CONDITIONS

If a communication flag is not set for the KOS-ECU, the ETACS-ECU determines that there is a failure.

## TROUBLESHOOTING HINTS

- Malfunction of the connector [joint connector (CAN1), KOS-ECU connector improperly connected]
- Malfunction of the wiring harness [open circuit between the KOS-ECU connector and the joint connector (CAN1), power supply circuit to the KOS-ECU]
- Malfunction of the KOS-ECU

## DIAGNOSIS

### Required Special Tools:

- MB991223: Harness Set
- MB992006: Extra Fine Probe

**STEP 1. Check joint connector (CAN1) C-105 and KOS-ECU connector C-05 for loose, corroded or damaged terminals, or terminals pushed back in the connector.**

### **⚠ CAUTION**

The strand end of the twisted wire should be within 10 cm (4 inches) from the connector. For details refer to [P.54C-7](#).

**Q: Are joint connector (CAN1) C-105 and KOS-ECU connector C-05 in good condition?**

**YES :** Go to Step 2.

**NO :** Repair the damaged parts.

**STEP 2. Check the wiring harness between joint connector (CAN1) C-105 and KOS-ECU connector C-05 for open circuit.**

**⚠ CAUTION**

**Strictly observe the specified wiring harness repair procedure. For details refer to P.54C-7.**

- (1) Disconnect joint connector (CAN1) C-105 and KOS-ECU connector C-05, and check the wiring harness.
- (2) Check the wiring harness between joint connector (CAN1) C-105 (terminal 9) and KOS-ECU connector C-05 (terminal 1)

**OK: Continuity exists (2 Ω or less)**

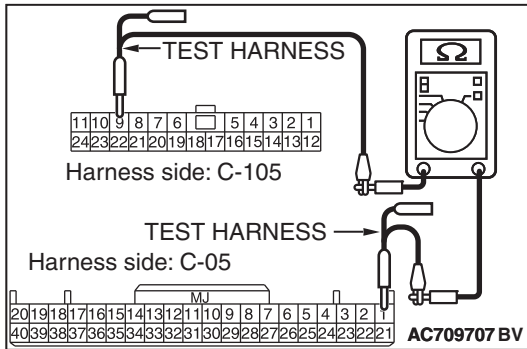

- (3) Check the wiring harness between joint connector (CAN1) C-105 (terminal 22) and KOS-ECU connector C-05 (terminal 2)

**OK: Continuity exists (2 Ω or less)**

**Q: Is the wiring harness between joint connector (CAN1) C-105 and KOS-ECU connector C-05 in good condition?**

**YES :** Check the power supply circuit of the KOS-ECU. Refer to GROUP 42B, KOS-ECU –Diagnosis P.42B-152.

**NO :** Repair the wiring harness between joint connector (CAN1) C-105 and KOS-ECU connector C-05.

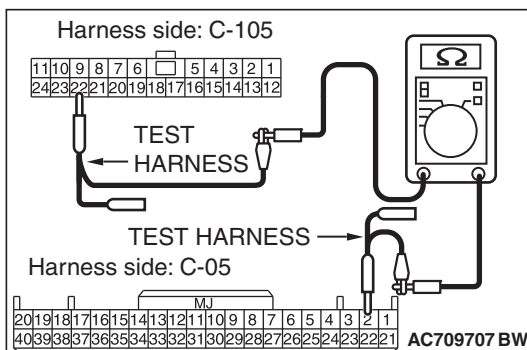

**DIAGNOSTIC ITEM 16: Diagnose when the scan tool cannot receive the data sent by WCM.**

**CAUTION**

When servicing a CAN bus line, ground yourself by touching a metal object such as an unpainted water pipe. If you fail to do so, a component connected to the CAN bus line may be damaged.

**CAN-B Communication Circuit**

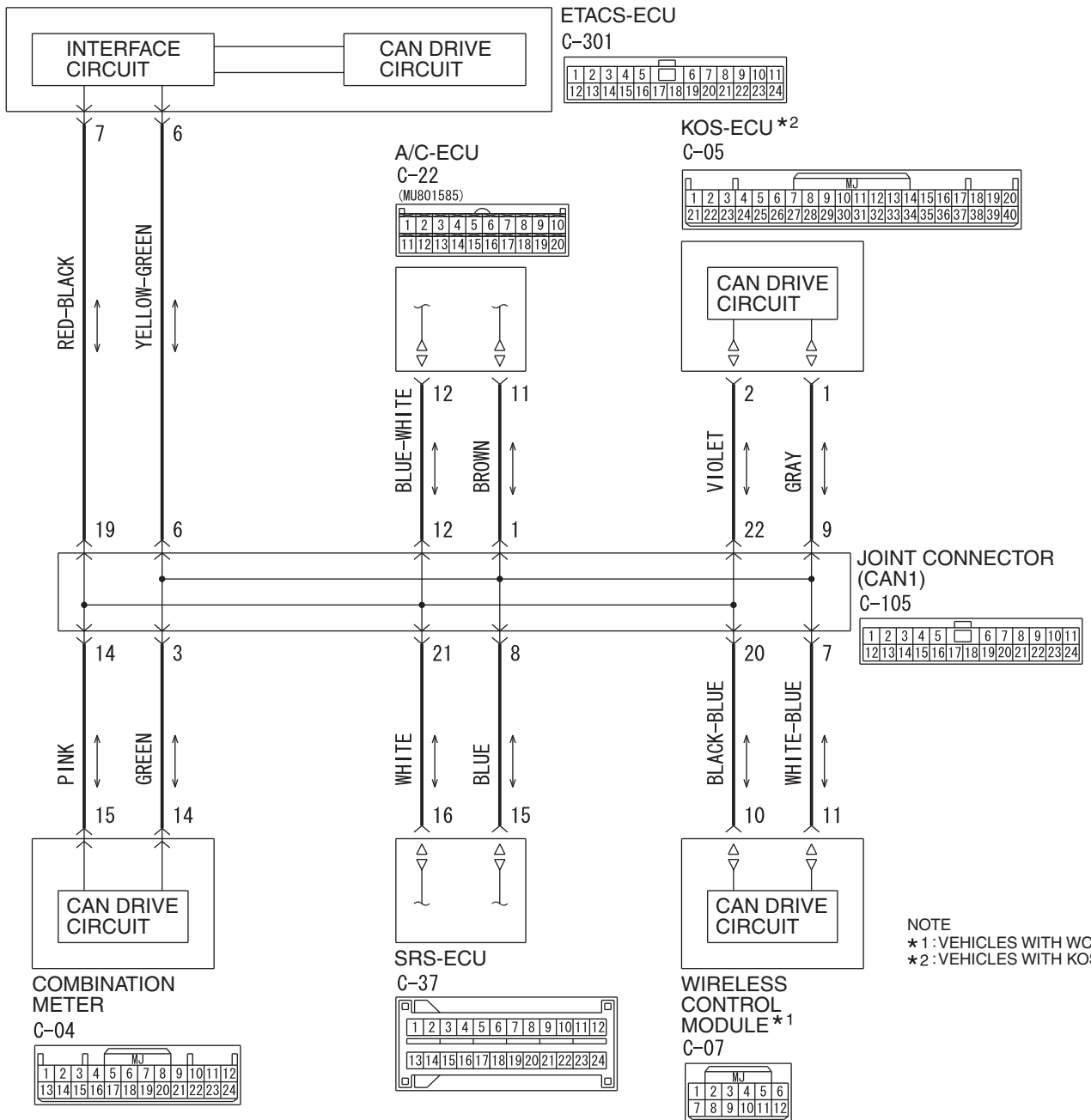

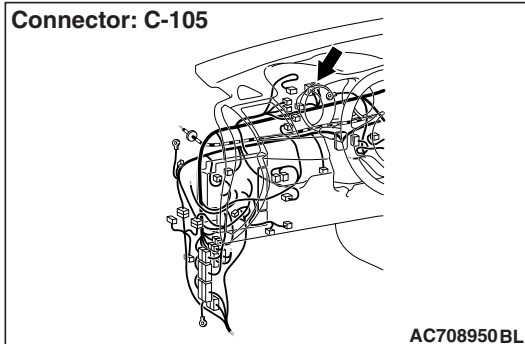
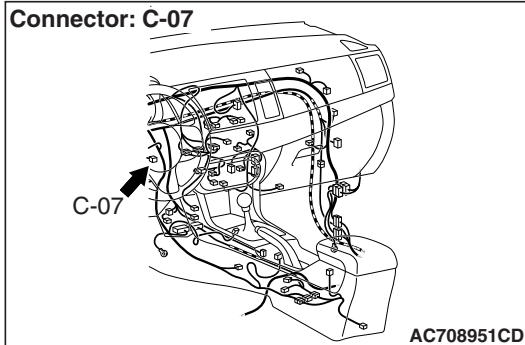

## FUNCTION

If the scan tool MB991958 cannot communicate with the WCM, this diagnosis result will be set.

## TROUBLE JUDGMENT CONDITIONS

If a communication flag is not set for the WCM, the ETACS-ECU determines that there is a failure.

## TROUBLESHOOTING HINTS

- Malfunction of the connector [joint connector (CAN1), WCM connector improperly connected]
- Malfunction of the wiring harness [open circuit between the WCM connector and the joint connector (CAN1), power supply circuit to the WCM]
- Malfunction of the WCM

## DIAGNOSIS

### Required Special Tools:

- MB991223: Harness Set
- MB992006: Extra Fine Probe

**STEP 1. Check joint connector (CAN1) C-105 and WCM connector C-07 for loose, corroded or damaged terminals, or terminals pushed back in the connector.**

### **⚠ CAUTION**

The strand end of the twisted wire should be within 10 cm (4 inches) from the connector. For details refer to [P.54C-7](#).

**Q: Are joint connector (CAN1) C-105 and WCM connector C-07 in good condition?**

**YES :** Go to Step 2.

**NO :** Repair the damaged parts.

**STEP 2. Check the wiring harness between joint connector (CAN1) C-105 and WCM connector C-07 for open circuit.**

**⚠ CAUTION**

**Strictly observe the specified wiring harness repair procedure. For details refer to P.54C-7.**

- (1) Disconnect joint connector (CAN1) C-105 and WCM connector C-07, and check the wiring harness.
- (2) Check the wiring harness between joint connector (CAN1) C-105 (terminal 7) and WCM connector C-07 (terminal 11)

**OK: Continuity exists (2 Ω or less)**

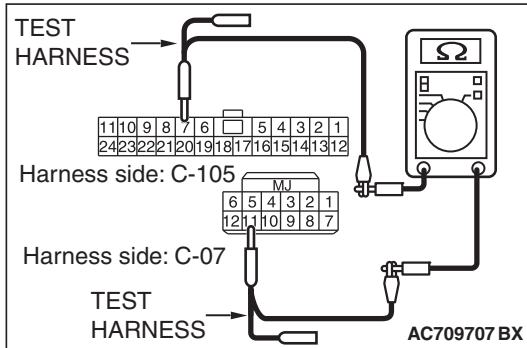

- (3) Check the wiring harness between joint connector (CAN1) C-105 (terminal 20) and WCM connector C-07 (terminal 10)

**OK: Continuity exists (2 Ω or less)**

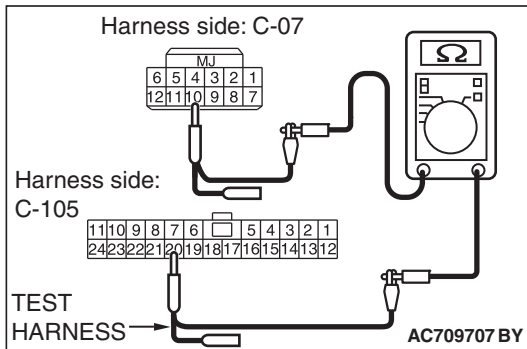

**Q: Is the wiring harness between joint connector (CAN1) C-105 and WCM connector C-07 in good condition?**

**YES :** Check the power supply circuit of the WCM. Refer to GROUP 42C, WCM –Diagnosis P.42C-91.

**NO :** Repair the wiring harness between joint connector (CAN1) C-105 and WCM connector C-07.

DIAGNOSTIC ITEM 17: Diagnose when the scan tool cannot receive the data sent by SRS-ECU.

**CAUTION**

When servicing a CAN bus line, ground yourself by touching a metal object such as an unpainted water pipe. If you fail to do so, a component connected to the CAN bus line may be damaged.

CAN-B Communication Circuit

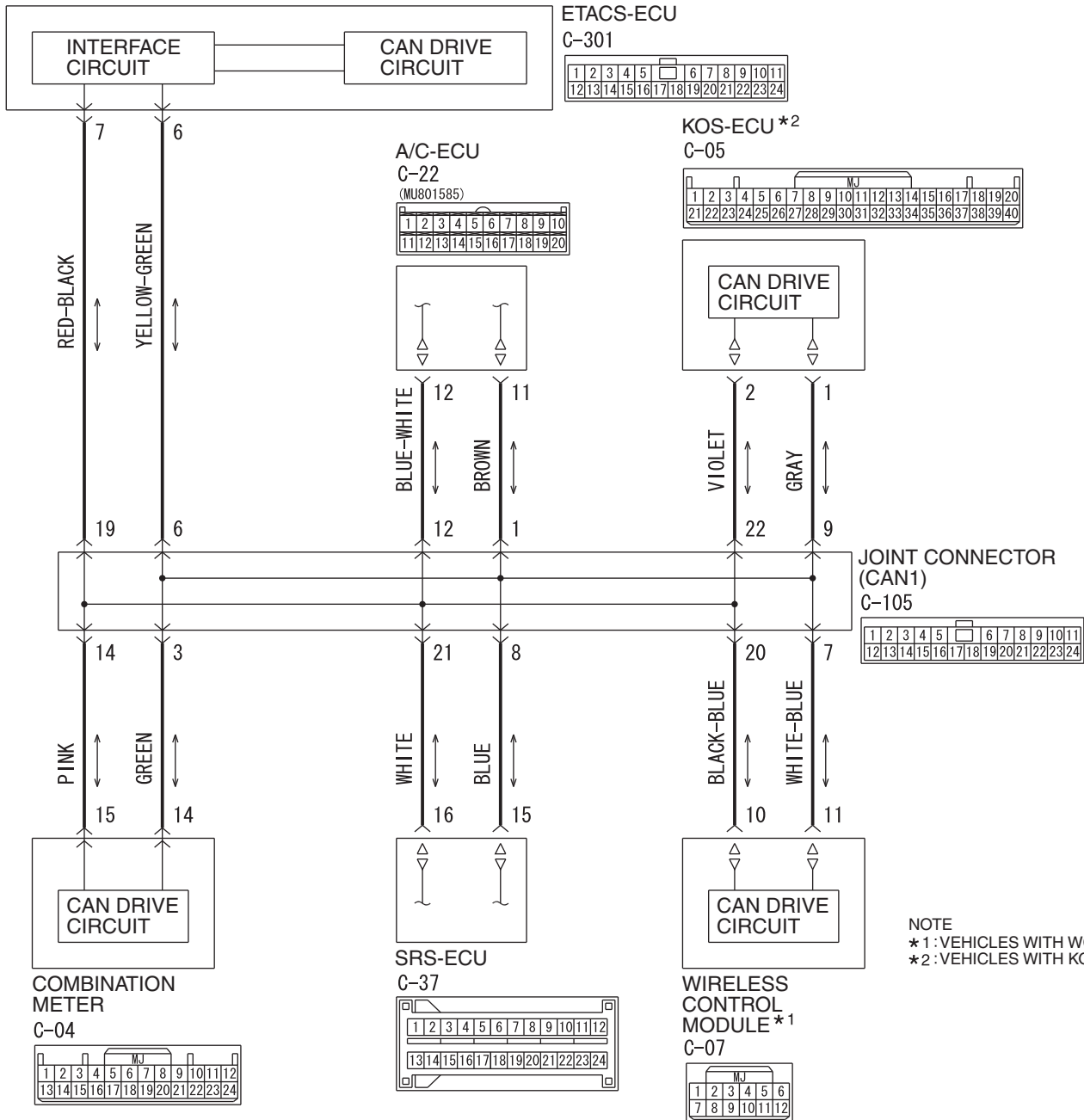

NOTE  
\*1 : VEHICLES WITH WCM  
\*2 : VEHICLES WITH KOS

Connector: C-37

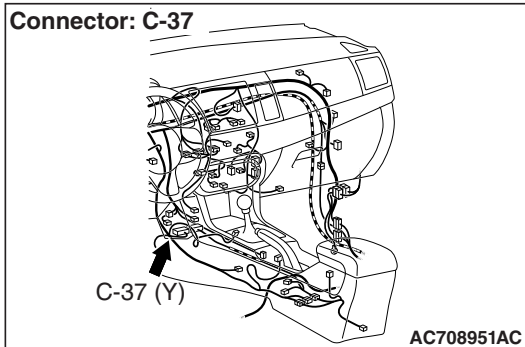

Connector: C-105

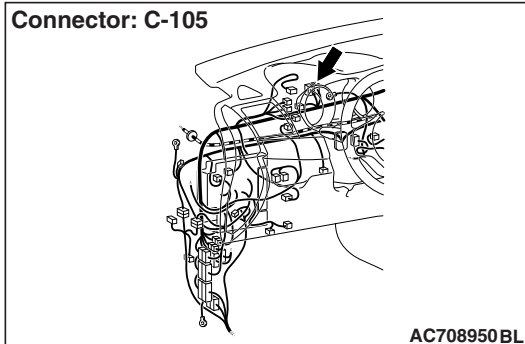

## FUNCTION

If the scan tool MB991958 cannot communicate with the SRS-ECU, this diagnosis result will be set.

## TROUBLE JUDGMENT CONDITIONS

If a communication flag is not set for the SRS-ECU, the ETACS-ECU determines that there is a failure.

## TROUBLESHOOTING HINTS

- Malfunction of the connector [joint connector (CAN1), SRS-ECU connector improperly connected]
- Malfunction of the wiring harness [open circuit between the SRS-ECU connector and the joint connector (CAN1), power supply circuit to the SRS-ECU]
- Malfunction of the SRS-ECU

## DIAGNOSIS

### Required Special Tools:

- MB991223: Harness Set
- MB992006: Extra Fine Probe

**STEP 1. Check joint connector (CAN1) C-105 and SRS-ECU connector C-37 for loose, corroded or damaged terminals, or terminals pushed back in the connector.**

### **⚠ CAUTION**

The strand end of the twisted wire should be within 10 cm (4 inches) from the connector. For details refer to [P.54C-7](#).

**Q: Are joint connector (CAN1) C-105 and SRS-ECU connector C-37 in good condition?**

**YES :** Go to Step 2.

**NO :** Repair the damaged parts.

**STEP 2. Check the wiring harness between joint connector (CAN1) C-105 and SRS-ECU connector C-37 for open circuit.**

**⚠ CAUTION**

**Strictly observe the specified wiring harness repair procedure. For details refer to P.54C-7.**

- (1) Disconnect joint connector (CAN1) C-105 and SRS-ECU connector C-37, and check the wiring harness.
- (2) Check the wiring harness between joint connector (CAN1) C-105 (terminal 8) and SRS-ECU connector C-37 (terminal 15)

**OK: Continuity exists (2 Ω or less)**

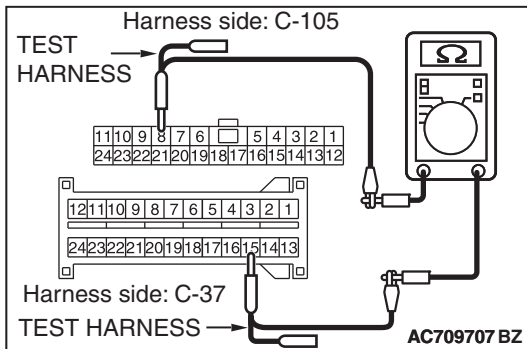

- (3) Check the wiring harness between joint connector (CAN1) C-105 (terminal 21) and SRS-ECU connector C-37 (terminal 16)

**OK: Continuity exists (2 Ω or less)**

**Q: Is the wiring harness between joint connector (CAN1) C-105 and SRS-ECU connector C-37 in good condition?**

**YES :** Check the power supply circuit of the SRS-ECU. Refer to GROUP 52B, SRS –Troubleshooting P.52B-383.

**NO :** Repair the wiring harness between joint connector (CAN1) C-105 and SRS-ECU connector C-37.

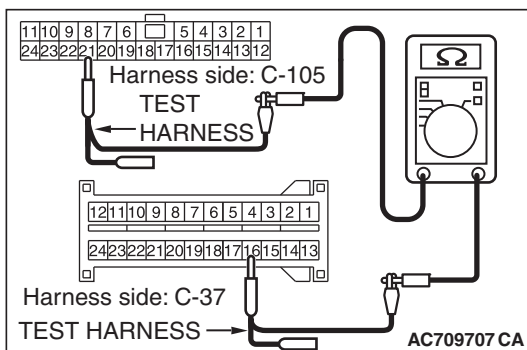



**DIAGNOSTIC ITEM 18: Diagnose when the scan tool cannot receive the data sent by occupant classification-ECU.**

**CAUTION**

When servicing a CAN bus line, ground yourself by touching a metal object such as an unpainted water pipe. If you fail to do so, a component connected to the CAN bus line may be damaged.

CAN-B Communication Circuit

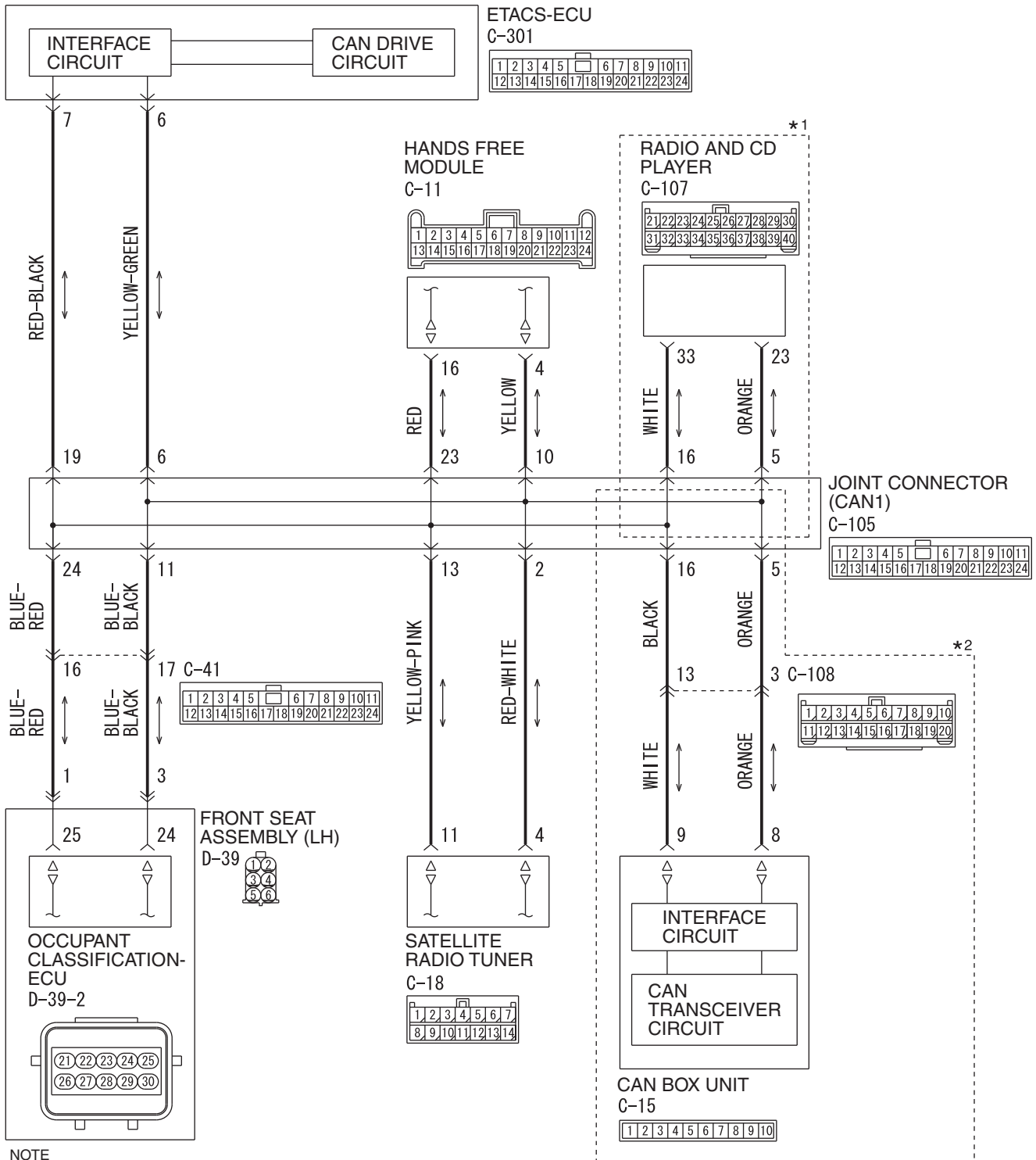

NOTE  
\*1: VEHICLES WITHOUT MITSUBISHI MULTI-COMMUNICATION SYSTEM (MMCS)  
\*2: VEHICLES WITH MITSUBISHI MULTI-COMMUNICATION SYSTEM (MMCS)

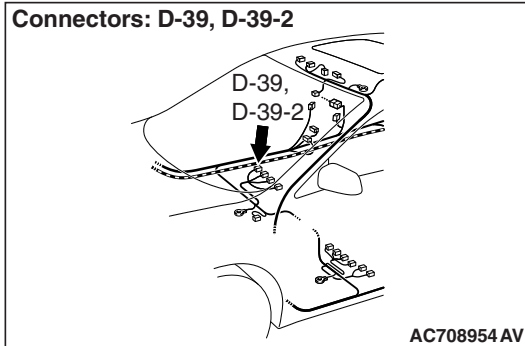
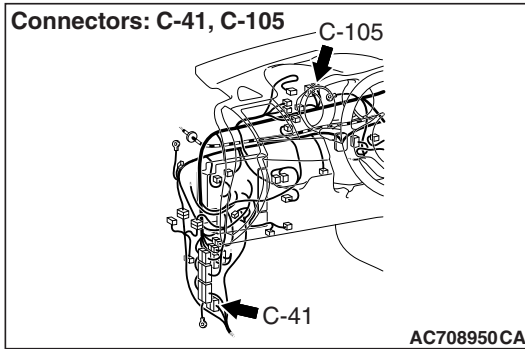

## FUNCTION

If the scan tool MB991958 cannot communicate with the occupant classification-ECU, this diagnosis result will be set.

## TROUBLE JUDGMENT CONDITIONS

If a communication flag is not set for the occupant classification-ECU, the ETACS-ECU determines that there is a failure.

## TROUBLESHOOTING HINTS

- Malfunction of the connector [joint connector (CAN1), occupant classification-ECU connector improperly connected]
- Malfunction of the wiring harness [open circuit between the occupant classification-ECU connector and the joint connector (CAN1), power supply circuit to the occupant classification-ECU]
- Malfunction of the occupant classification-ECU

## DIAGNOSIS

### Required Special Tools:

- MB991223: Harness Set
- MB992006: Extra Fine Probe

**STEP 1. Check joint connector (CAN1) C-105, occupant classification-ECU connector D-39, D-39-2 and intermediate connector C-41 for loose, corroded or damaged terminals, or terminals pushed back in the connector.**

### **⚠ CAUTION**

The strand end of the twisted wire should be within 10 cm (4 inches) from the connector. For details refer to [P.54C-7](#).

**Q: Are joint connector (CAN1) C-105, occupant classification-ECU connector D-39, D-39-2 and intermediate connector C-41 in good condition?**

**YES :** Go to Step 2.

**NO :** Repair the damaged parts.

**STEP 2. Check the wiring harness between joint connector (CAN1) C-105 and occupant classification-ECU connector D-39-2 for open circuit.**

**⚠ CAUTION**

**Strictly observe the specified wiring harness repair procedure. For details refer to P.54C-7.**

- (1) Disconnect joint connector (CAN1) C-105 and occupant classification-ECU connector D-39-2, and check the wiring harness.
- (2) Check the wiring harness between joint connector (CAN1) C-105 (terminal 11) and occupant classification-ECU connector D-39-2 (terminal 24)

**OK: Continuity exists (2 Ω or less)**

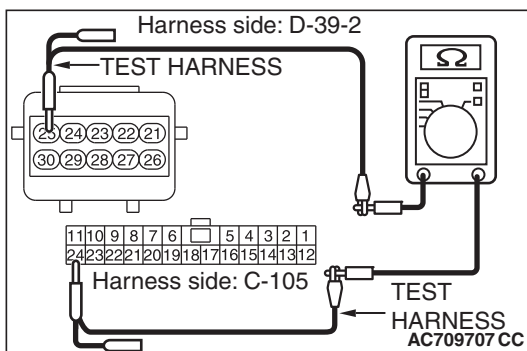
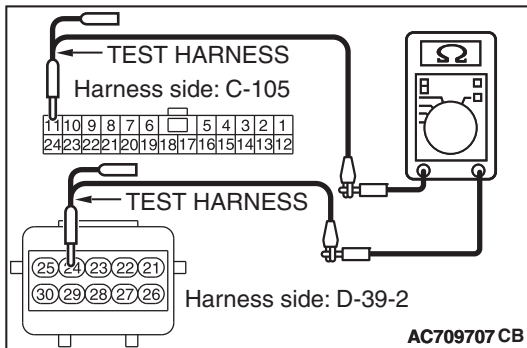

- (3) Check the wiring harness between joint connector (CAN1) C-105 (terminal 24) and occupant classification-ECU connector D-39-2 (terminal 25)

**OK: Continuity exists (2 Ω or less)**

**Q: Is the wiring harness between joint connector (CAN1) C-105 and occupant classification-ECU connector D-39-2 in good condition?**

**YES :** Check the power supply circuit of the occupant classification-ECU. Refer to GROUP 52B, SRS air bag Diagnosis P.52B-383.

**NO :** Repair the wiring harness between joint connector (CAN1) C-105 and occupant classification-ECU connector D-39-2.

**DIAGNOSTIC ITEM 19: Diagnose when the scan tool cannot receive the data sent by A/C-ECU <vehicles with A/C> or heater control unit <vehicles without A/C>.**

**CAUTION**

When servicing a CAN bus line, ground yourself by touching a metal object such as an unpainted water pipe. If you fail to do so, a component connected to the CAN bus line may be damaged.

**CAN-B Communication Circuit**

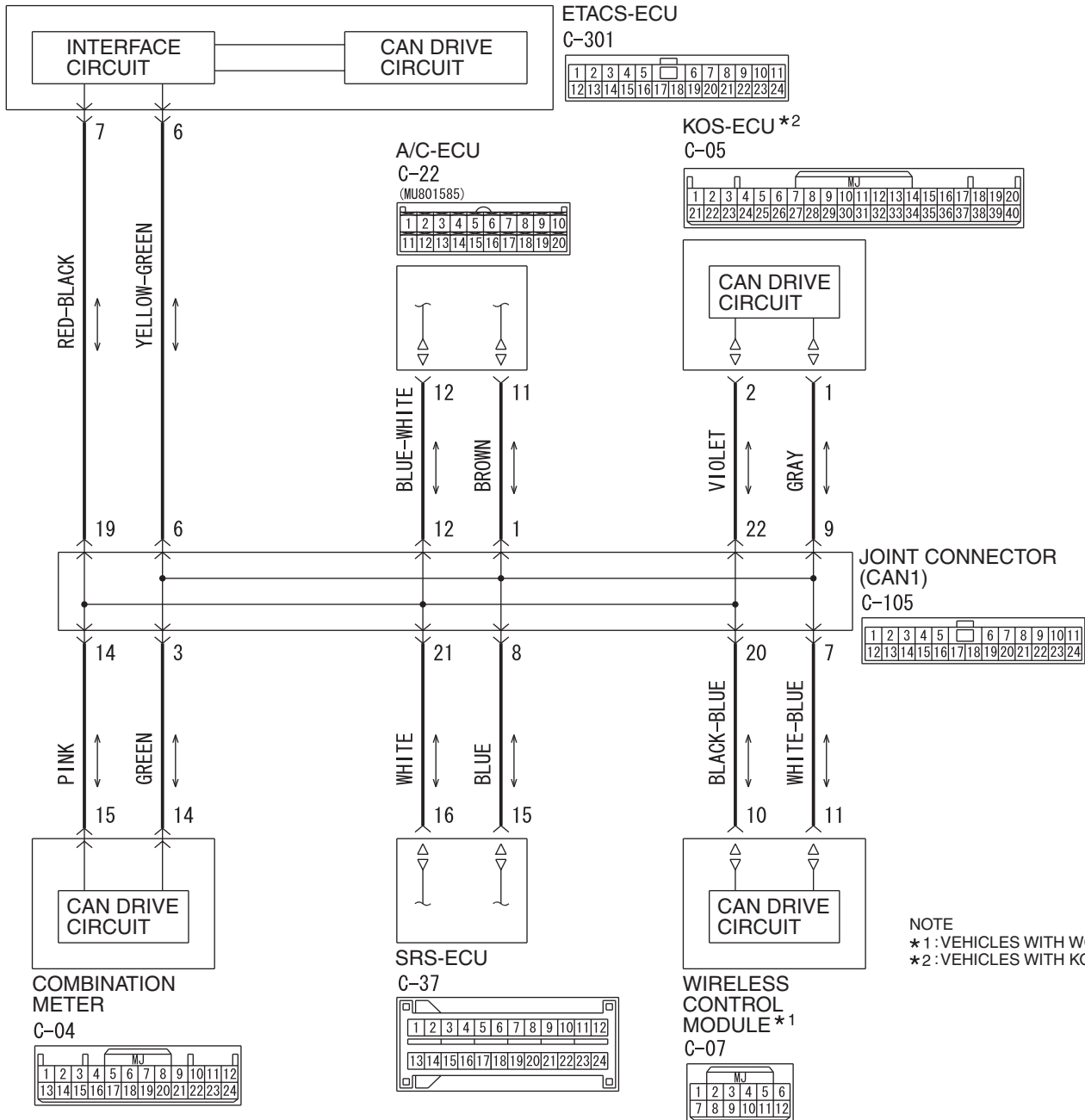

Connector: C-22

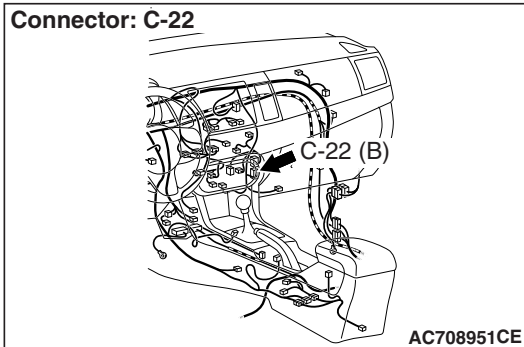

Connector: C-105

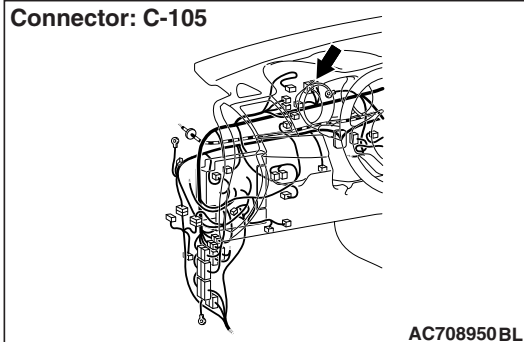

## FUNCTION

If the scan tool MB991958 cannot communicate with the A/C-ECU <vehicles with A/C> or heater control unit <vehicles without A/C>, this diagnosis result will be set.

## TROUBLE JUDGMENT CONDITIONS

If a communication flag is not set for the A/C-ECU <vehicles with A/C> or heater control unit <vehicles without A/C>, the ETACS-ECU determines that there is a failure.

## TROUBLESHOOTING HINTS

- Malfunction of the connector [joint connector (CAN1), A/C-ECU <vehicles with A/C> or heater control unit <vehicles without A/C> connector improperly connected]
- Malfunction of the wiring harness [open circuit between the A/C-ECU <vehicles with A/C> or heater control unit <vehicles without A/C> connector and the joint connector (CAN1), power supply circuit to the A/C-ECU <vehicles with A/C> or heater control unit <vehicles without A/C>]
- Malfunction of the A/C-ECU <vehicles with A/C> or heater control unit <vehicles without A/C>

## DIAGNOSIS

### Required Special Tools:

- MB991223: Harness Set
- MB992006: Extra Fine Probe

**STEP 1. Check joint connector (CAN1) C-105 and A/C-ECU connector C-22 <vehicles with A/C> or heater control unit connector C-53 <vehicles without A/C> for loose, corroded or damaged terminals, or terminals pushed back in the connector.**

### CAUTION

The strand end of the twisted wire should be within 10 cm (4 inches) from the connector. For details refer to [P.54C-7](#).

**Q: Are joint connector (CAN1) C-105 and A/C-ECU connector C-22 <vehicles with A/C> or heater control unit connector C-53 <vehicles without A/C> in good condition?**

**YES :** Go to Step 2.

**NO :** Repair the damaged parts.

**STEP 2. Check the wiring harness between joint connector (CAN1) C-105 and A/C-ECU connector C-22 <vehicles with A/C> or heater control unit connector C-53 <vehicles without A/C> for open circuit.**

**⚠ CAUTION**

**Strictly observe the specified wiring harness repair procedure. For details refer to P.54C-7.**

- (1) Disconnect joint connector (CAN1) C-105 and A/C-ECU connector C-22 <vehicles with A/C> or heater control unit connector C-53 <vehicles without A/C>, and check the wiring harness.
- (2) Check the wiring harness between joint connector (CAN1) C-105 (terminal 1) and A/C-ECU connector C-22 <vehicles with A/C> or heater control unit connector C-53 <vehicles without A/C> (terminal 11)

**OK: Continuity exists (2 Ω or less)**

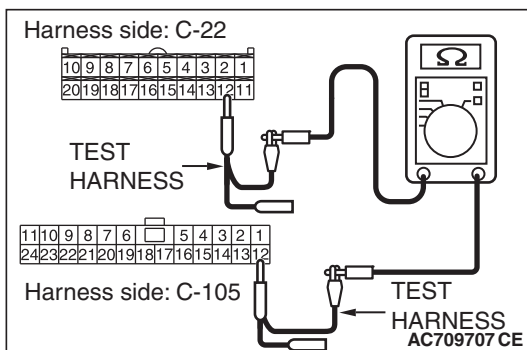
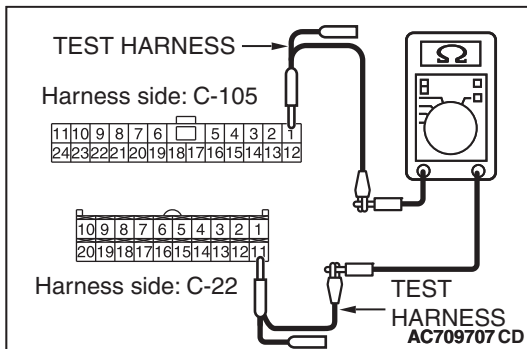

- (3) Check the wiring harness between joint connector (CAN1) C-105 (terminal 12) and A/C-ECU connector C-22 <vehicles with A/C> or heater control unit connector C-53 <vehicles without A/C> (terminal 12)

**OK: Continuity exists (2 Ω or less)**

**Q: Is the wiring harness between joint connector (CAN1) C-105 and A/C-ECU connector C-22 <vehicles with A/C> or heater control unit connector C-53 <vehicles without A/C> in good condition?**

**YES :** Check the power supply circuit of the A/C-ECU <vehicles with A/C> or heater control unit <vehicles without A/C>. Refer to GROUP 55, Diagnosis [P.55-121](#) <vehicles with A/C> or [P.55-96](#) <vehicles without A/C>.

**NO :** Repair the wiring harness between joint connector (CAN1) C-105 and A/C-ECU connector C-22 <vehicles with A/C> or heater control unit connector C-53 <vehicles without A/C>.

**DIAGNOSTIC ITEM 20: Diagnose when the scan tool cannot receive the data sent by radio and CD player or CD player or CD changer.**

**CAUTION**

When servicing a CAN bus line, ground yourself by touching a metal object such as an unpainted water pipe. If you fail to do so, a component connected to the CAN bus line may be damaged.

CAN-B Communication Circuit

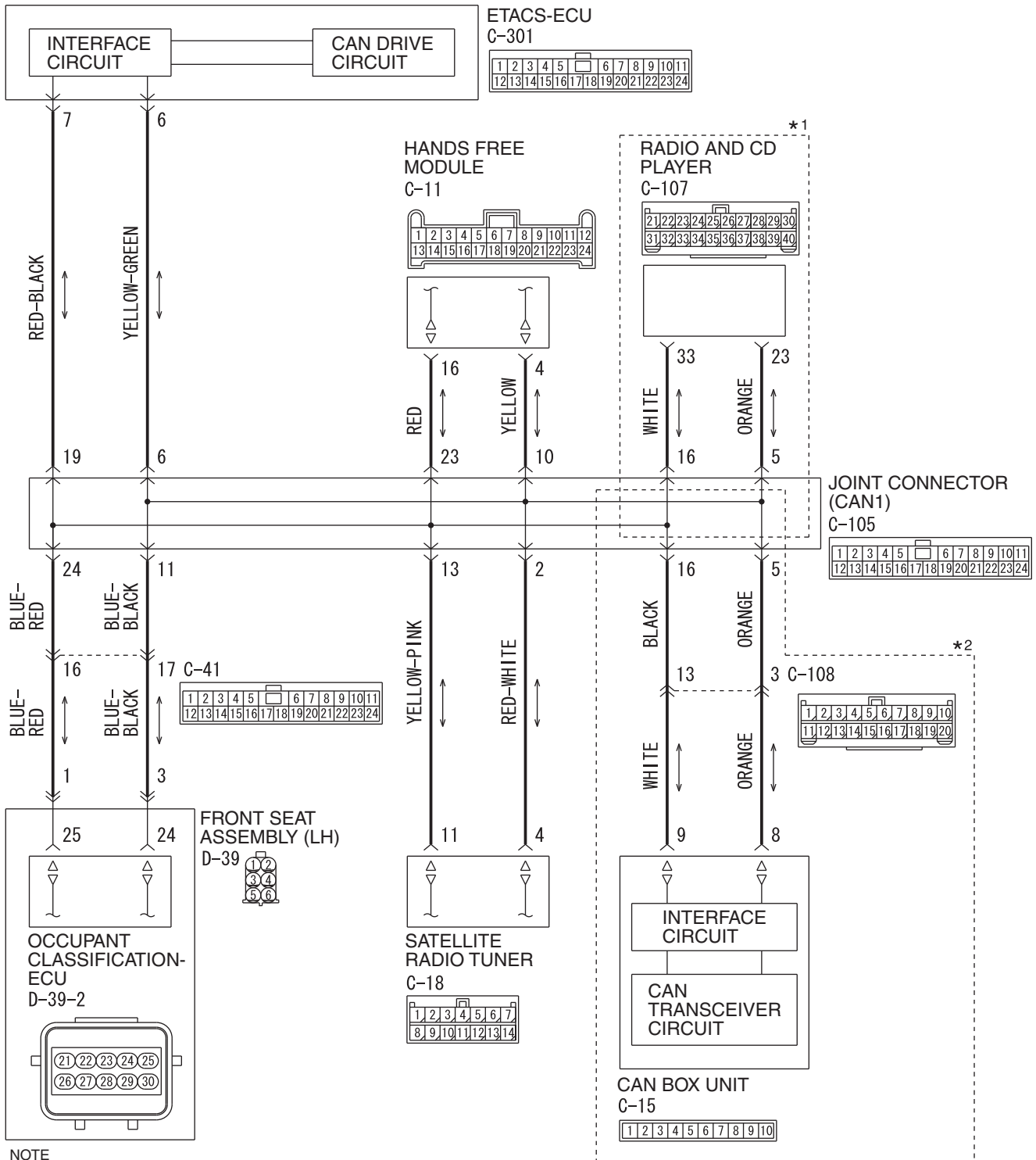

NOTE  
\*1: VEHICLES WITHOUT MITSUBISHI MULTI-COMMUNICATION SYSTEM (MMCS)  
\*2: VEHICLES WITH MITSUBISHI MULTI-COMMUNICATION SYSTEM (MMCS)

Connector: C-105

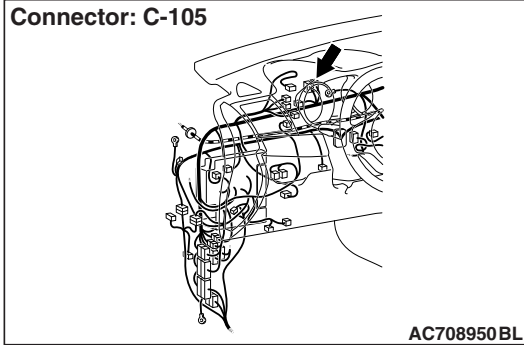

Connector: C-107

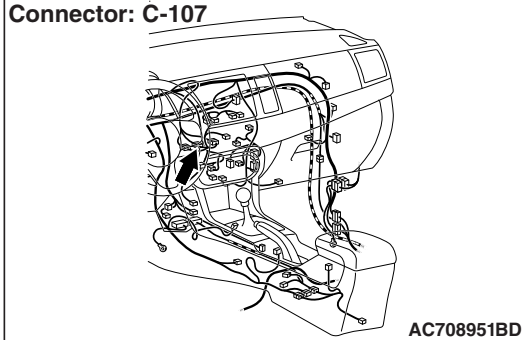
**FUNCTION**

If the scan tool MB991958 cannot communicate with the radio and CD player or CD changer, this diagnosis result will be set.

**TROUBLE JUDGMENT CONDITIONS**

If a communication flag is not set for the radio and CD player or CD changer, the ETACS-ECU determines that there is a failure.

**TROUBLESHOOTING HINTS**

- Malfunction of the connector [joint connector (CAN1), radio and CD player or CD changer connector improperly connected]
- Malfunction of the wiring harness [open circuit between the radio and CD player or CD changer connector and the joint connector (CAN1), power supply circuit to the radio and CD player or CD changer]
- Malfunction of the radio and CD player or CD changer

**DIAGNOSIS****Required Special Tools:**

- MB991223: Harness Set
- MB992006: Extra Fine Probe

**STEP 1.** Check joint connector (CAN1) C-105 and radio and CD player or CD changer connector C-107 for loose, corroded or damaged terminals, or terminals pushed back in the connector.

**⚠ CAUTION**

The strand end of the twisted wire should be within 10 cm (4 inches) from the connector. For details refer to [P.54C-7](#).

**Q:** Are joint connector (CAN1) C-105 and radio and CD player or CD changer connector C-107 in good condition?

**YES :** Go to Step 2.

**NO :** Repair the damaged parts.



**STEP 2. Check the wiring harness between joint connector (CAN1) C-105 and radio and CD player or CD changer connector C-107 for open circuit.**

**⚠ CAUTION**

**Strictly observe the specified wiring harness repair procedure. For details refer to P.54C-7.**

- (1) Disconnect joint connector (CAN1) C-105 and radio and CD player or CD changer connector C-107, and check the wiring harness.
- (2) Check the wiring harness between joint connector (CAN1) C-105 (terminal 5) and radio and CD player or CD changer connector C-107 (terminal 23)

**OK: Continuity exists (2 Ω or less)**

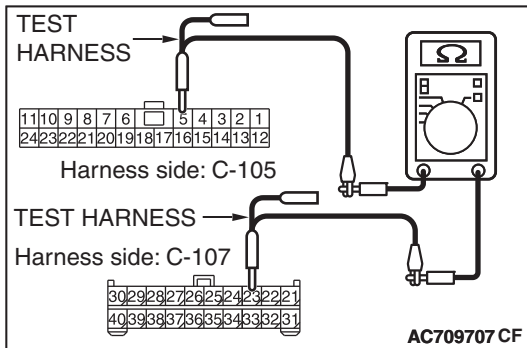

- (3) Check the wiring harness between joint connector (CAN1) C-105 (terminal 16) and radio and CD player or CD changer connector C-107 (terminal 33)

**OK: Continuity exists (2 Ω or less)**

**Q: Is the wiring harness between joint connector (CAN1) C-105 and radio and CD player or CD changer connector C-107 in good condition?**

**YES :** Check the power supply circuit of the radio and CD player or CD changer. Refer to GROUP 54A, radio and CD player –Diagnosis <radio and CD player> P.54A-356.

**NO :** Repair the wiring harness between joint connector (CAN1) C-105 and radio and CD player or CD changer connector C-107.

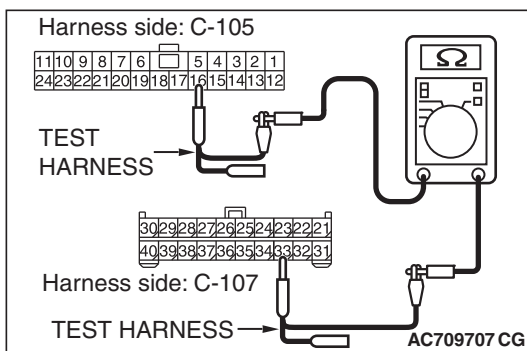

**DIAGNOSTIC ITEM 21: Diagnose when the scan tool cannot receive the data sent by CAN box unit.**

**CAUTION**

When servicing a CAN bus line, ground yourself by touching a metal object such as an unpainted water pipe. If you fail to do so, a component connected to the CAN bus line may be damaged.

CAN-B Communication Circuit

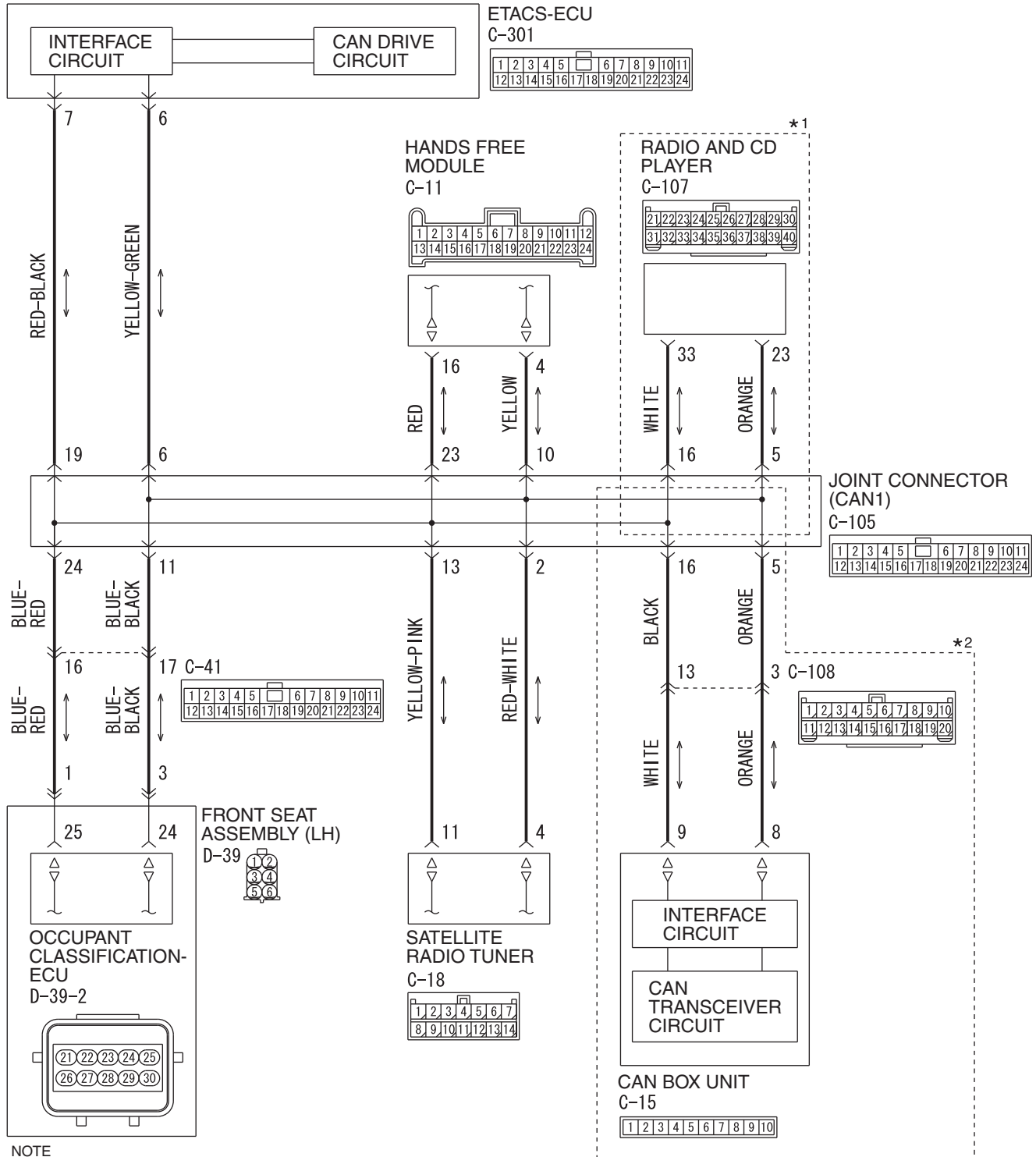

NOTE  
 \*1 : VEHICLES WITHOUT MITSUBISHI MULTI-COMMUNICATION SYSTEM (MMCS)  
 \*2 : VEHICLES WITH MITSUBISHI MULTI-COMMUNICATION SYSTEM (MMCS)

Connectors: C-15, C-108

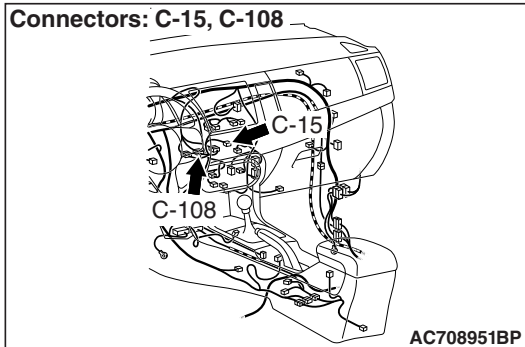

AC708951BP

Connector: C-105

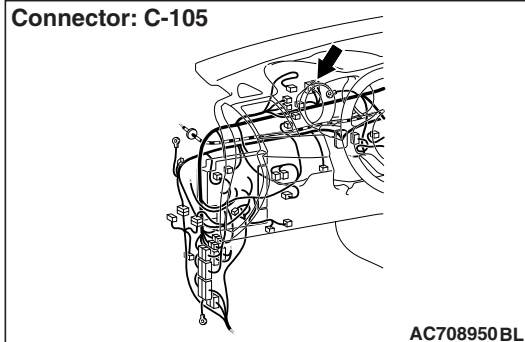

AC708950BL

## FUNCTION

If the scan tool MB991958 cannot communicate with the CAN box unit, this diagnosis result will be set.

## TROUBLE JUDGMENT CONDITIONS

If a communication flag is not set for the CAN box unit, the ETACS-ECU determines that there is a failure.

## TROUBLESHOOTING HINTS

- Malfunction of the connector [joint connector (CAN1), CAN box unit connector improperly connected]
- Malfunction of the wiring harness [open circuit between the CAN box unit connector and the joint connector (CAN1), power supply circuit to the CAN box unit]
- Malfunction of the CAN box unit

## DIAGNOSIS

### Required Special Tools:

- MB991223: Harness Set
- MB992006: Extra Fine Probe

**STEP 1. Check joint connector (CAN1) C-105, CAN box unit connector C-15 and intermediate connector C-108 for loose, corroded or damaged terminals, or terminals pushed back in the connector.**

### **⚠ CAUTION**

The strand end of the twisted wire should be within 10 cm (4 inches) from the connector. For details refer to [P.54C-7](#).

**Q: Are joint connector (CAN1) C-105, CAN box unit connector C-15 and intermediate connector C-108 in good condition?**

**YES :** Go to Step 2.

**NO :** Repair the damaged parts.

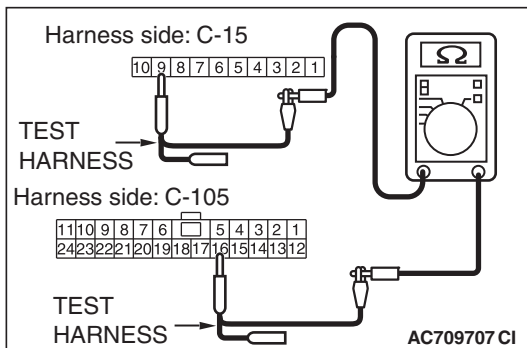
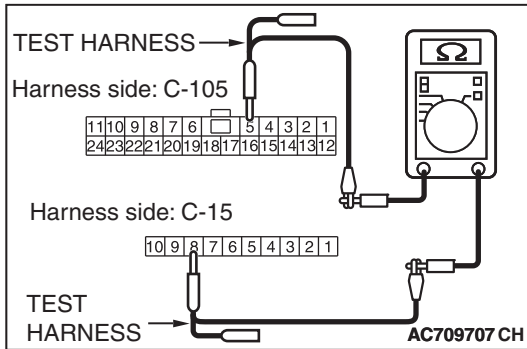

**STEP 2. Check the wiring harness between joint connector (CAN1) C-105 and CAN box unit connector C-15 for open circuit.**

**⚠ CAUTION**

**Strictly observe the specified wiring harness repair procedure. For details refer to P.54C-7.**

- (1) Disconnect joint connector (CAN1) C-105 and CAN box unit connector C-15, and check the wiring harness.
- (2) Check the wiring harness between joint connector (CAN1) C-105 (terminal 5) and CAN box unit connector C-15 (terminal 8)

**OK: Continuity exists (2 Ω or less)**

- (3) Check the wiring harness between joint connector (CAN1) C-105 (terminal 16) and CAN box unit connector C-15 (terminal 9)

**OK: Continuity exists (2 Ω or less)**

**Q: Is the wiring harness between joint connector (CAN1) C-105 and CAN box unit connector C-15 in good condition?**

**YES :** Check the power supply circuit of the CAN box unit. Refer to GROUP 54A, Diagnosis <MMCS>

[P.54A-457.](#)

**NO :** Repair the wiring harness between joint connector (CAN1) C-105 and CAN box unit connector C-15.

**DIAGNOSTIC ITEM 22: Diagnose when the scan tool cannot receive the data sent by satellite radio tuner.**

**CAUTION**

When servicing a CAN bus line, ground yourself by touching a metal object such as an unpainted water pipe. If you fail to do so, a component connected to the CAN bus line may be damaged.

CAN-B Communication Circuit

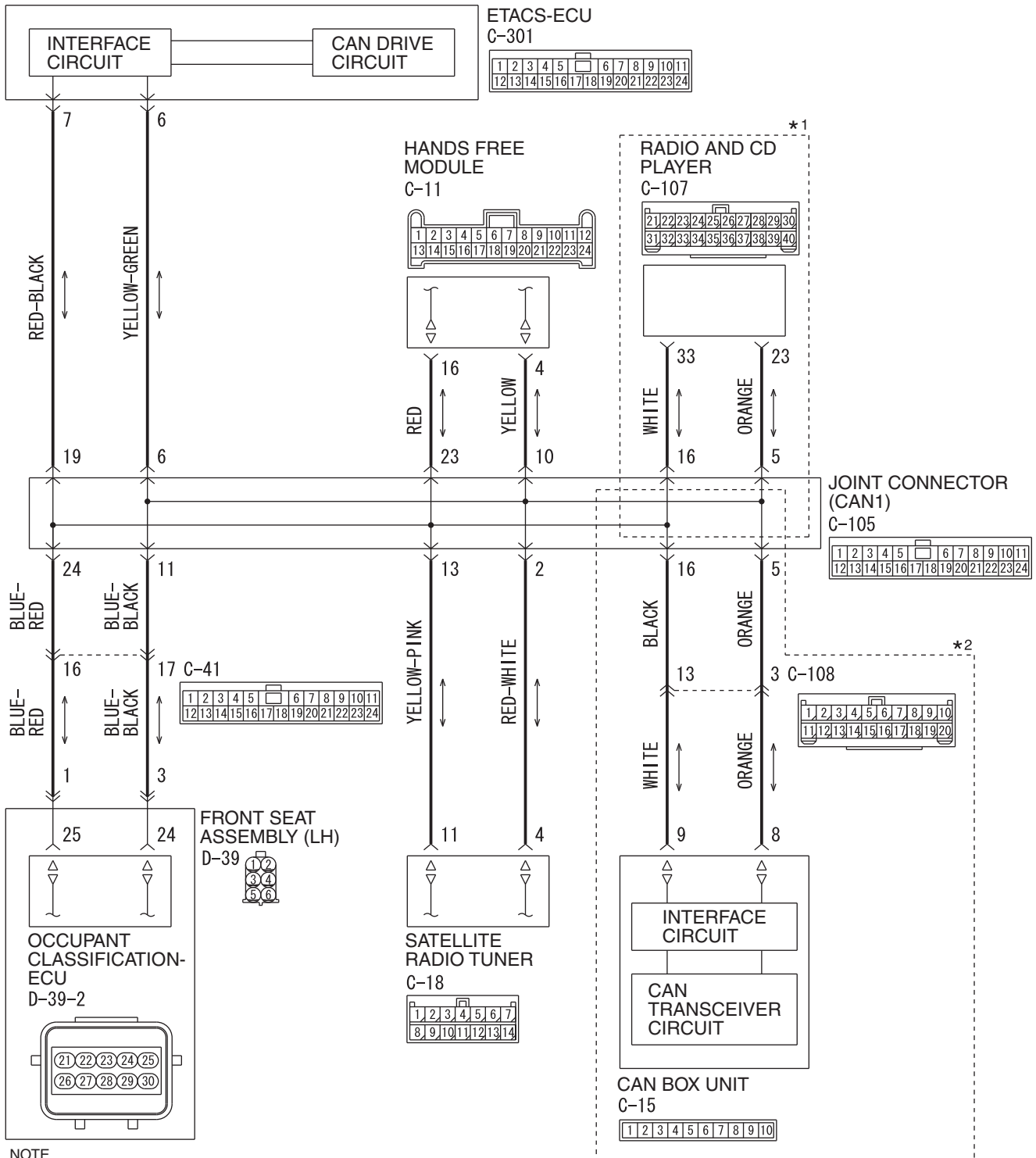

NOTE  
\*1: VEHICLES WITHOUT MITSUBISHI MULTI-COMMUNICATION SYSTEM (MMCS)  
\*2: VEHICLES WITH MITSUBISHI MULTI-COMMUNICATION SYSTEM (MMCS)

Connector: C-18

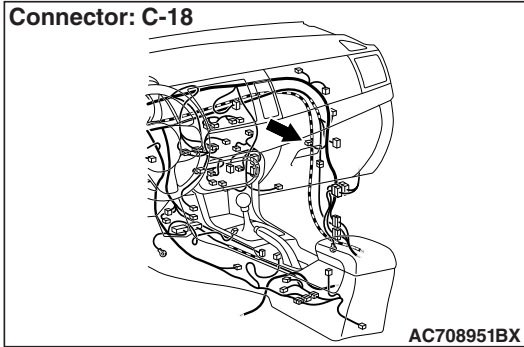

Connector: C-105

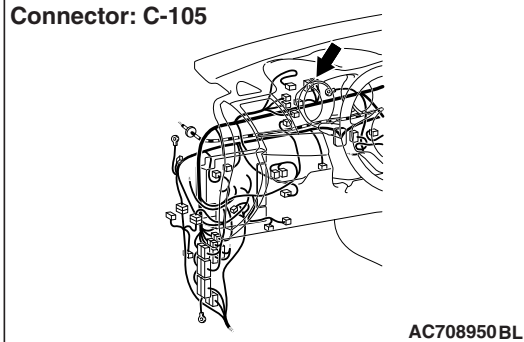
**FUNCTION**

If the scan tool MB991958 cannot communicate with the satellite radio tuner, this diagnosis result will be set.

**TROUBLE JUDGMENT CONDITIONS**

If a communication flag is not set for the satellite radio tuner, the ETACS-ECU determines that there is a failure.

**TROUBLESHOOTING HINTS**

- Malfunction of the connector [joint connector (CAN1), satellite radio tuner connector improperly connected]
- Malfunction of the wiring harness [open circuit between the satellite radio tuner connector and the joint connector (CAN1), power supply circuit to the satellite radio tuner]
- Malfunction of the satellite radio tuner

**DIAGNOSIS****Required Special Tools:**

- MB991223: Harness Set
- MB992006: Extra Fine Probe

**STEP 1. Check joint connector (CAN1) C-105 and satellite radio tuner connector C-18 for loose, corroded or damaged terminals, or terminals pushed back in the connector.**

**⚠ CAUTION**

The strand end of the twisted wire should be within 10 cm (4 inches) from the connector. For details refer to [P.54C-7](#).

**Q: Are joint connector (CAN1) C-105 and satellite radio tuner connector C-18 in good condition?**

**YES :** Go to Step 2.

**NO :** Repair the damaged parts.

**STEP 2. Check the wiring harness between joint connector (CAN1) C-105 and satellite radio tuner connector C-18 for open circuit.**

**⚠ CAUTION**

**Strictly observe the specified wiring harness repair procedure. For details refer to P.54C-7.**

- (1) Disconnect joint connector (CAN1) C-105 and satellite radio tuner connector C-18, and check the wiring harness.
- (2) Check the wiring harness between joint connector (CAN1) C-105 (terminal 2) and satellite radio tuner connector C-18 (terminal 4)

**OK: Continuity exists (2 Ω or less)**

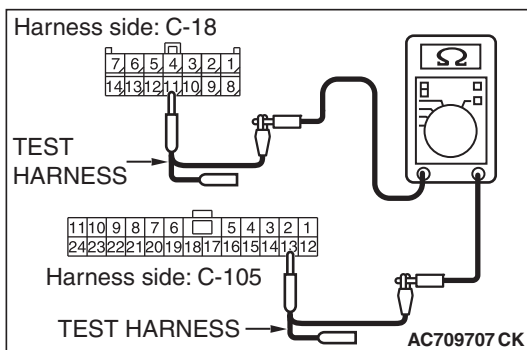
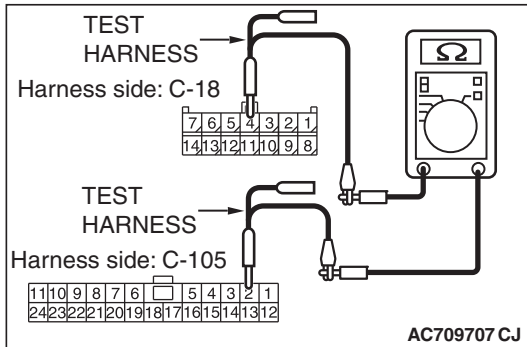

- (3) Check the wiring harness between joint connector (CAN1) C-105 (terminal 13) and satellite radio tuner connector C-18 (terminal 11)

**OK: Continuity exists (2 Ω or less)**

**Q: Is the wiring harness between joint connector (CAN1) C-105 and satellite radio tuner connector C-18 in good condition?**

**YES :** Check the power supply circuit of the satellite radio tuner. Refer to GROUP 54A, Diagnosis <Satellite radio tuner> P.54A-617.

**NO :** Repair the wiring harness between joint connector (CAN1) C-105 and satellite radio tuner connector C-18.

**DIAGNOSTIC ITEM 23: Diagnose when the scan tool cannot receive the data sent by hands free module.**

**CAUTION**

When servicing a CAN bus line, ground yourself by touching a metal object such as an unpainted water pipe. If you fail to do so, a component connected to the CAN bus line may be damaged.

CAN-B Communication Circuit

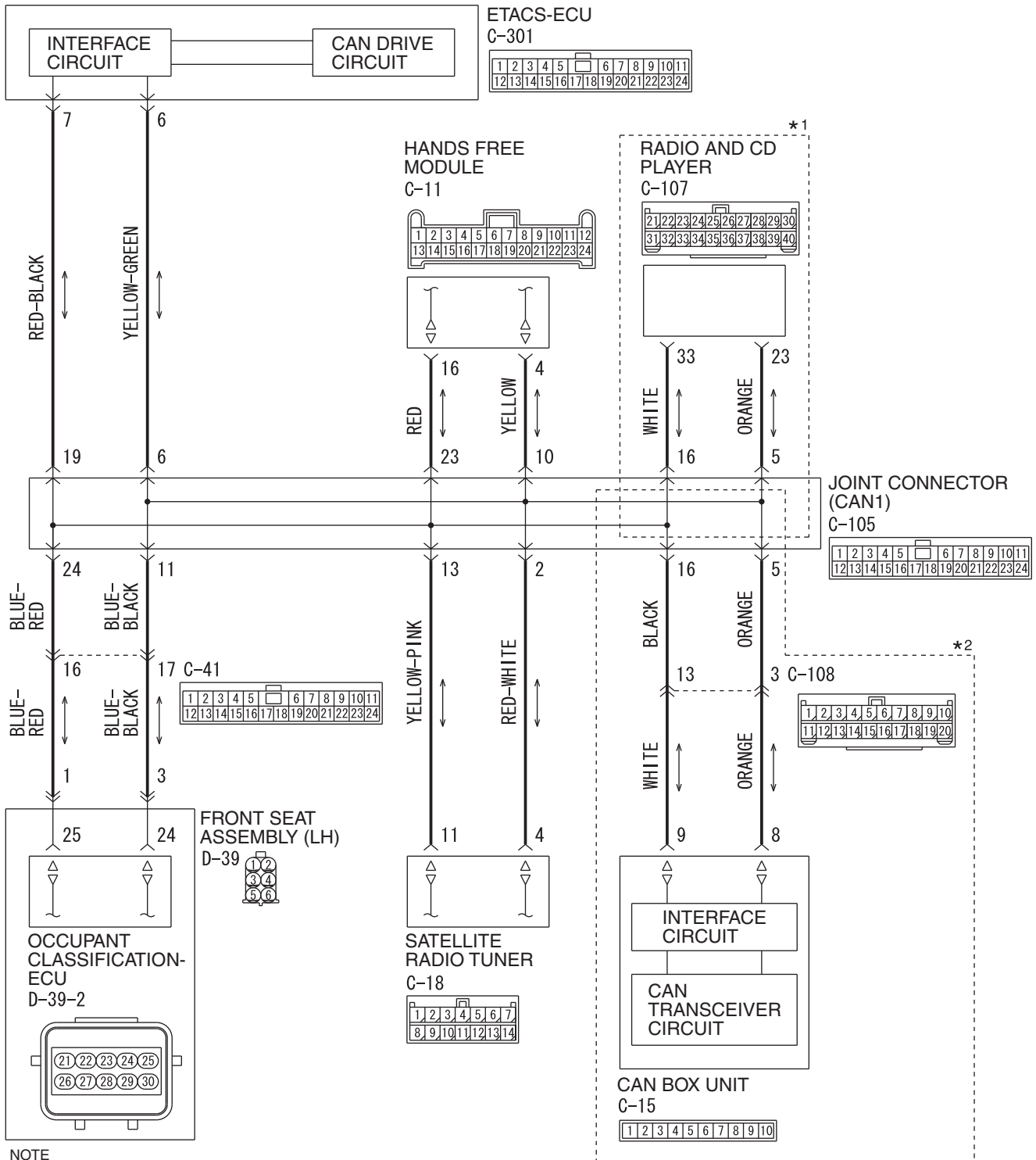

NOTE  
\*1 : VEHICLES WITHOUT MITSUBISHI MULTI-COMMUNICATION SYSTEM (MMCS)  
\*2 : VEHICLES WITH MITSUBISHI MULTI-COMMUNICATION SYSTEM (MMCS)



Connector: C-11

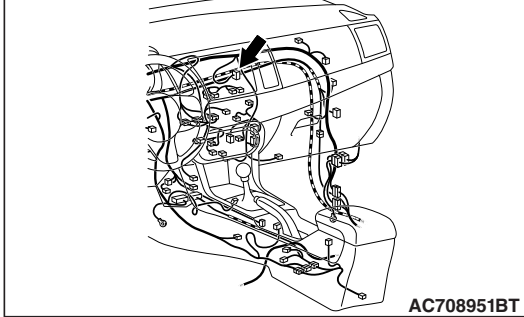

## FUNCTION

If the scan tool MB991958 cannot communicate with the hands free module, this diagnosis result will be set.

## TROUBLE JUDGMENT CONDITIONS

If a communication flag is not set for the hands free module, the ETACS-ECU determines that there is a failure.

Connector: C-105

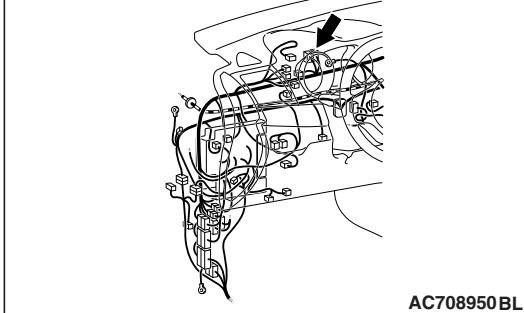

## TROUBLESHOOTING HINTS

- Malfunction of the connector [joint connector (CAN1), hands free module connector improperly connected]
- Malfunction of the wiring harness [open circuit between the hands free module connector and the joint connector (CAN1), power supply circuit to the hands free module]
- Malfunction of the hands free module

## DIAGNOSIS

### Required Special Tools:

- MB991223: Harness Set
- MB992006: Extra Fine Probe

**STEP 1. Check joint connector (CAN1) C-105 and hands free module connector C-11 for loose, corroded or damaged terminals, or terminals pushed back in the connector.**

### CAUTION

The strand end of the twisted wire should be within 10 cm (4 inches) from the connector. For details refer to [P.54C-7](#).

**Q: Are joint connector (CAN1) C-105 and hands free module connector C-11 in good condition?**

**YES :** Go to Step 2.

**NO :** Repair the damaged parts.

**STEP 2.** Check the wiring harness between joint connector (CAN1) C-105 and hands free module connector C-11 for open circuit.

**⚠ CAUTION**

Strictly observe the specified wiring harness repair procedure. For details refer to [P.54C-7](#).

- (1) Disconnect joint connector (CAN1) C-105 and hands free module connector C-11, and check the wiring harness.
- (2) Check the wiring harness between joint connector (CAN1) C-105 (terminal 10) and hands free module connector C-11 (terminal 4)

**OK: Continuity exists (2 Ω or less)**

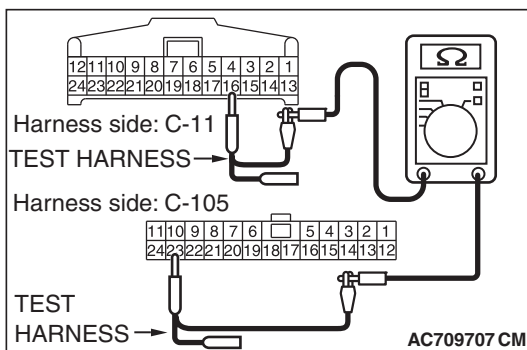
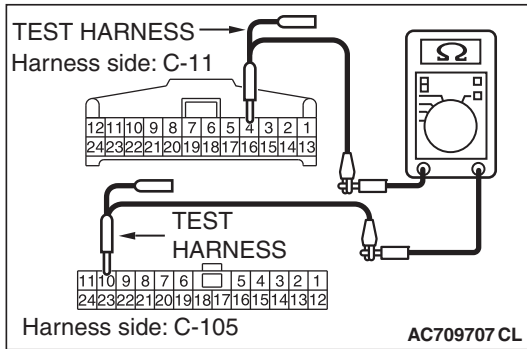

- (3) Check the wiring harness between joint connector (CAN1) C-105 (terminal 23) and hands free module connector C-11 (terminal 16)

**OK: Continuity exists (2 Ω or less)**

**Q: Is the wiring harness between joint connector (CAN1) C-105 and hands free module connector C-11 in good condition?**

**YES :** Check the power supply circuit of the hands free module. Refer to GROUP 54A, Hands-free cellular phone system –Diagnosis <Hands-free cellular phone system> [P.54A-546](#).

**NO :** Repair the wiring harness between joint connector (CAN1) C-105 and hands free module connector C-11.

**DIAGNOSTIC ITEM 24:** Diagnose when the scan tool cannot receive the data sent by combination meter.

**CAUTION**

When servicing a CAN bus line, ground yourself by touching a metal object such as an unpainted water pipe. If you fail to do so, a component connected to the CAN bus line may be damaged.

CAN-B Communication Circuit

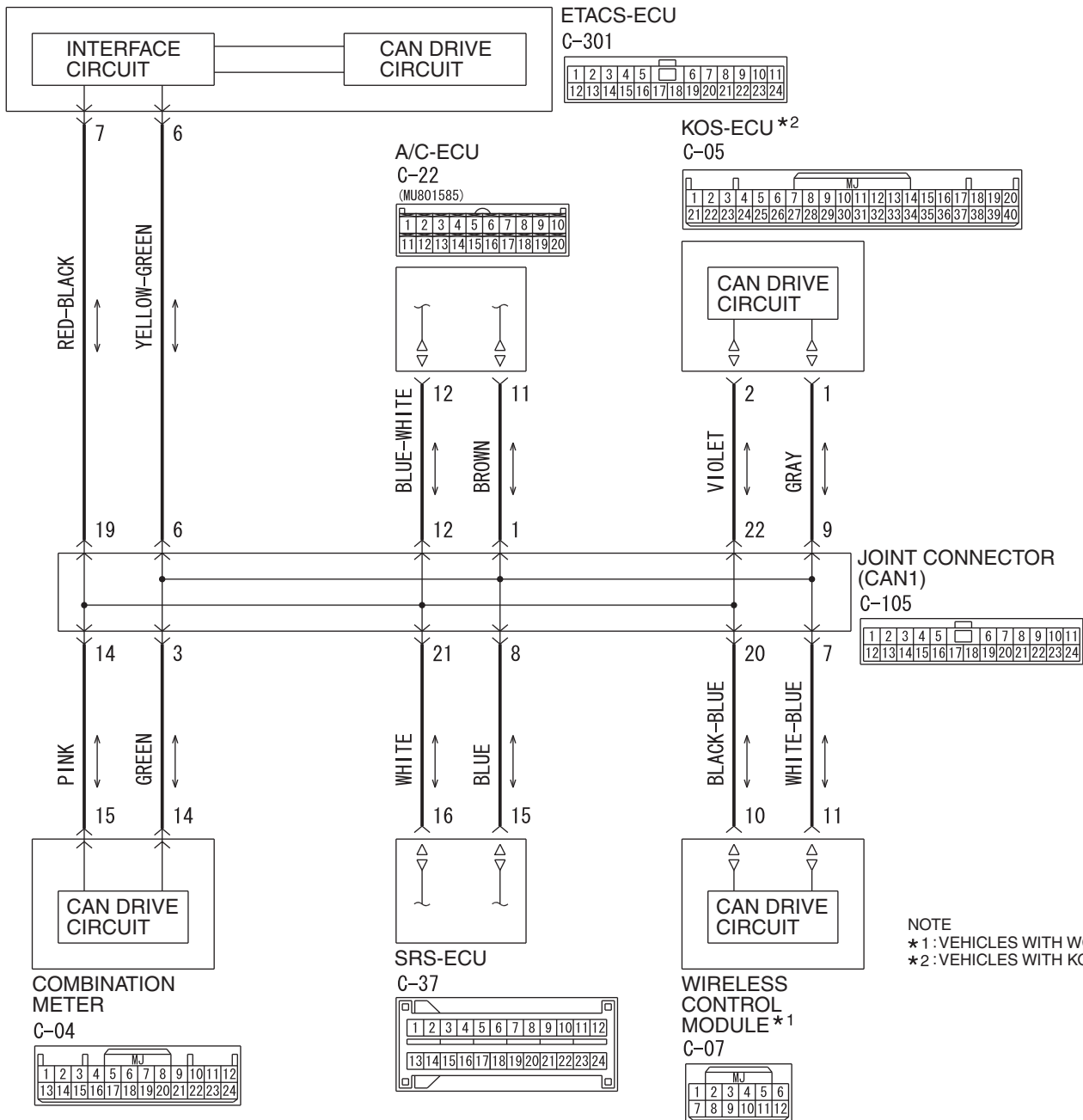

NOTE  
\*1 : VEHICLES WITH WCM  
\*2 : VEHICLES WITH KOS

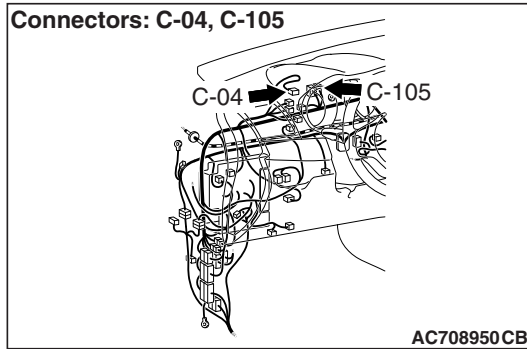

## FUNCTION

If the scan tool MB991958 cannot communicate with the combination meter, this diagnosis result will be set.

## TROUBLE JUDGMENT CONDITIONS

If a communication flag is not set for the combination meter, the ETACS-ECU determines that there is a failure.

## TROUBLESHOOTING HINTS

- Malfunction of the connector [joint connector (CAN1), combination meter connector improperly connected]
- Malfunction of the wiring harness [open circuit between the combination meter connector and the joint connector (CAN1), power supply circuit to the combination meter]
- Malfunction of the combination meter

## DIAGNOSIS

### Required Special Tools:

- MB991223: Harness Set
- MB992006: Extra Fine Probe

**STEP 1. Check joint connector (CAN1) C-105 and combination meter connector C-04 for loose, corroded or damaged terminals, or terminals pushed back in the connector.**

### CAUTION

The strand end of the twisted wire should be within 10 cm (4 inches) from the connector. For details refer to [P.54C-7](#).

**Q: Are joint connector (CAN1) C-105 and combination meter connector C-04 in good condition?**

**YES :** Go to Step 2.

**NO :** Repair the damaged parts.

**STEP 2. Check the wiring harness between joint connector (CAN1) C-105 and combination meter connector C-04.**

**⚠ CAUTION**

Strictly observe the specified wiring harness repair procedure. For details refer to [P.54C-7](#).

- (1) Disconnect joint connector (CAN1) C-105 and combination meter connector C-04, and check the wiring harness.
- (2) Check the wiring harness between joint connector (CAN1) C-105 (terminal 3) and combination meter connector C-04 (terminal 14)

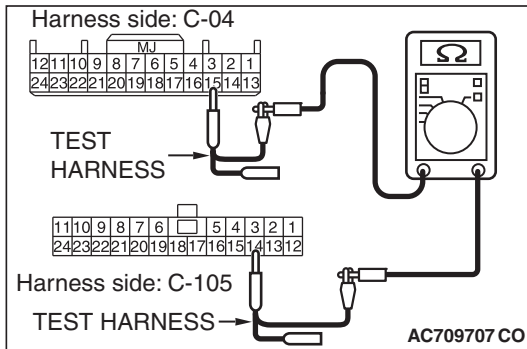
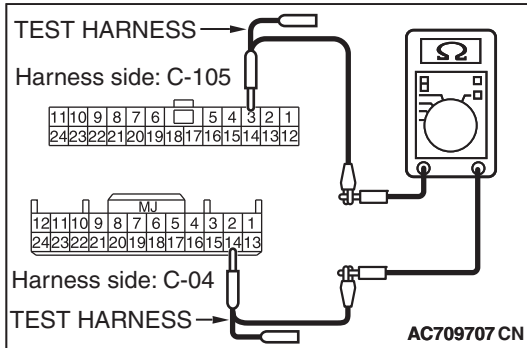

- (3) Check the wiring harness between joint connector (CAN1) C-105 (terminal 14) and combination meter connector C-04 (terminal 15)

**Q: Is the wiring harness between joint connector (CAN1) C-105 and combination meter connector C-04 in good condition?**

**YES :** Check the power supply circuit of the combination meter. Refer to GROUP 54A, combination meter – Diagnosis [P.54A-67](#).

**NO :** Repair the wiring harness between joint connector (CAN1) C-105 and combination meter connector C-04.

**DIAGNOSTIC ITEM 25: Short to power supply or ground in both CAN\_H and CAN\_L lines of the CAN-B bus lines.**

**CAUTION**

When servicing a CAN bus line, ground yourself by touching a metal object such as an unpainted water pipe. If you fail to do so, a component connected to the CAN bus line may be damaged.

**CAN-B Communication Circuit**

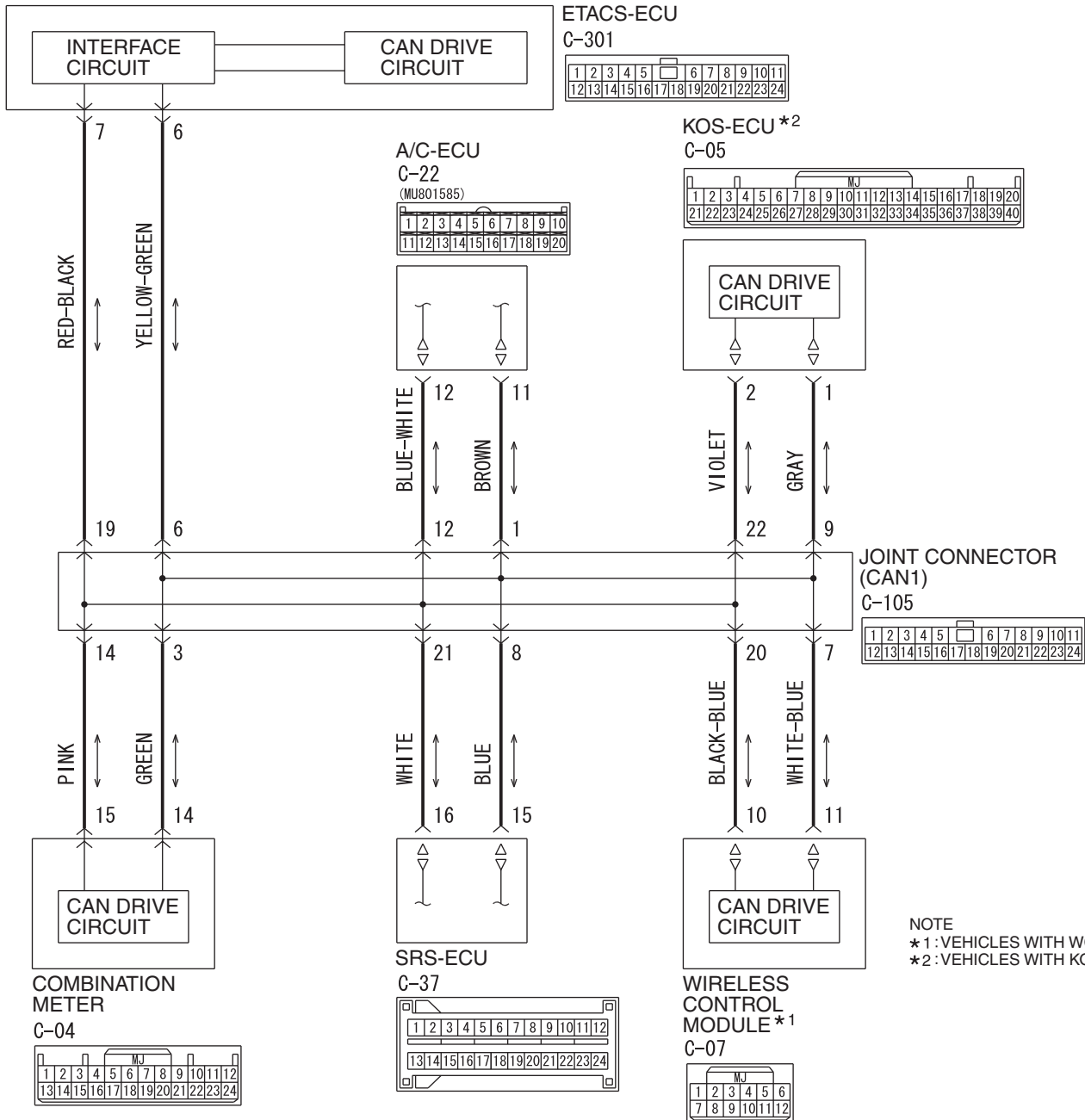

CAN-B Communication Circuit

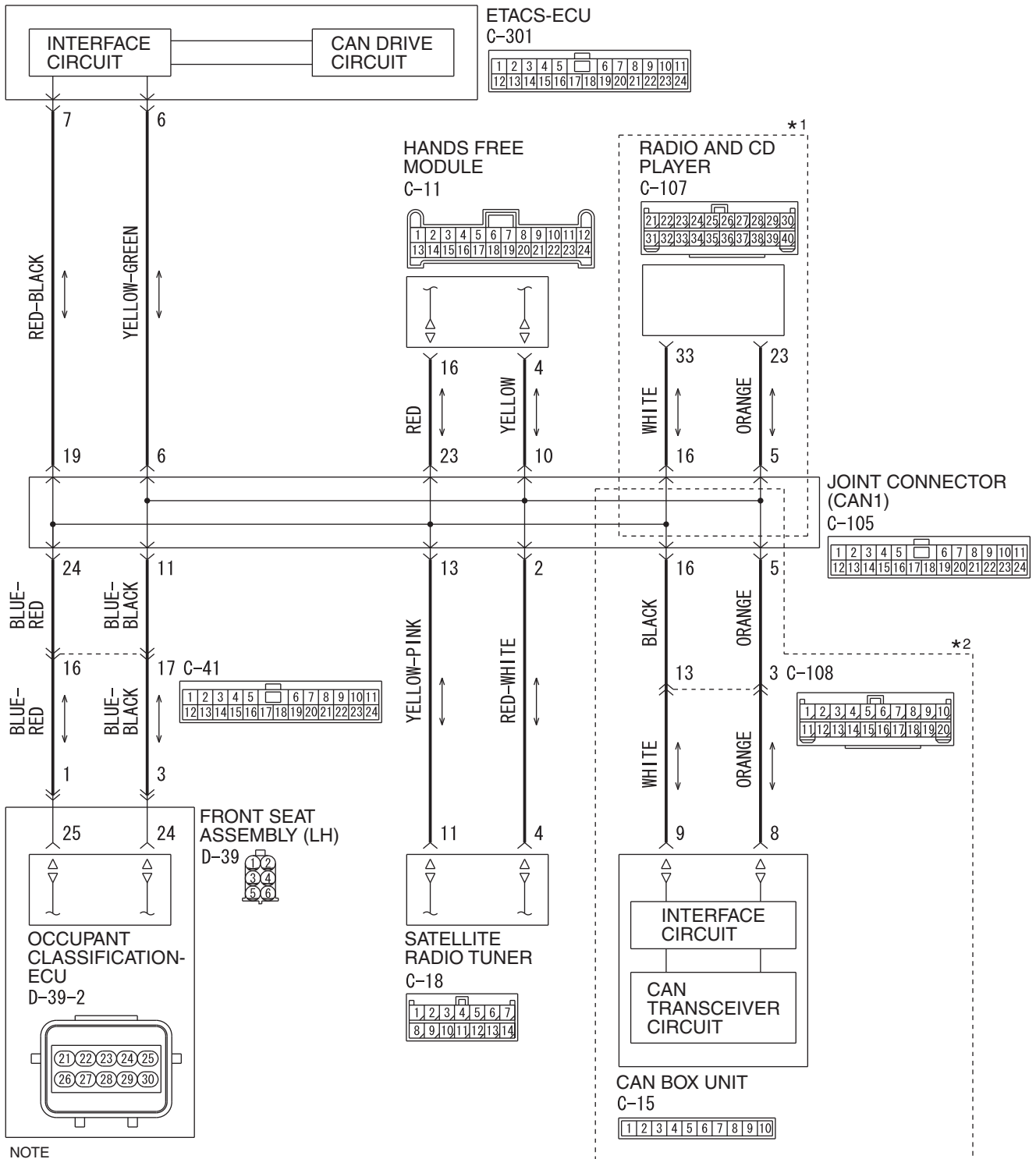

NOTE

- \*1: VEHICLES WITHOUT MITSUBISHI MULTI-COMMUNICATION SYSTEM (MMCS)
- \*2: VEHICLES WITH MITSUBISHI MULTI-COMMUNICATION SYSTEM (MMCS)

W9H54M093A

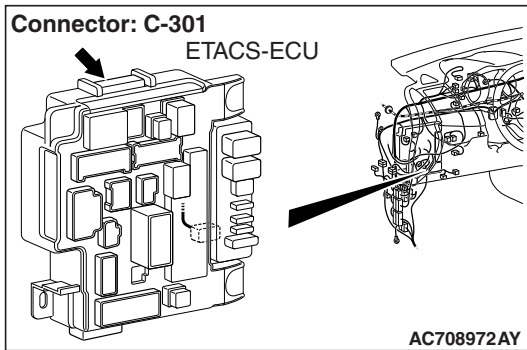
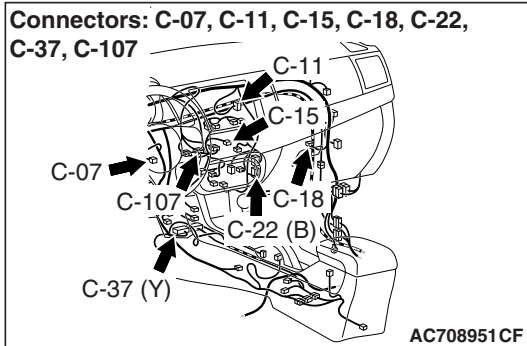
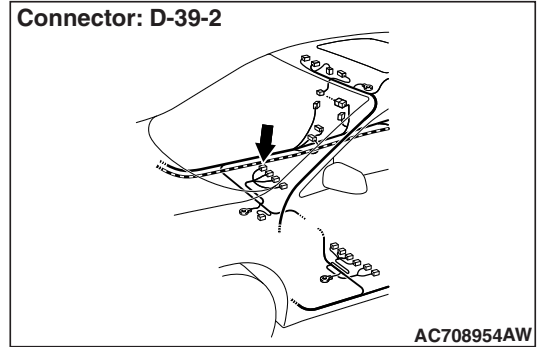
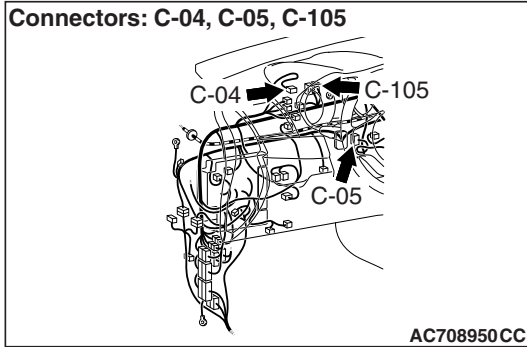

**FUNCTION**

If a short to power supply or ground is present in both CAN\_H and CAN\_L lines, this diagnosis result will be set.

**TROUBLE JUDGMENT CONDITIONS**

If a communication flag is set for the ETACS-ECU, no communication is present through the CAN-B line, and diagnostic trouble code U0019 is set, the ETACS-ECU determines that there is a failure.

**TROUBLESHOOTING HINTS**

- Malfunction of the connector (ETACS-ECU connector improperly connected)
- Malfunction of the wiring harness (CAN\_H and CAN\_L lines are short to power supply or ground on the CAN-B line.)
- Malfunction of ECUs



**DIAGNOSIS**

**Required Special Tools:**

- MB991223: Harness Set
- MB992006: Extra Fine Probe

**STEP 1. Check the wiring harness between ETACS-ECU connector C-301 and body ground for a short to power supply. Measure the voltage at ETACS-ECU connector C-301.**

**⚠ CAUTION**

**A digital multimeter should be used. For details refer to P.54C-7.**

**⚠ CAUTION**

**The test wiring harness should be used. For details refer to P.54C-7.**

- (1) Disconnect ETACS-ECU connector C-301, and measure the voltage at the wiring harness side of ETACS-ECU connector.
- (2) Turn the ignition switch to the ON position.
- (3) Measure the voltage between ETACS-ECU connector terminal 6 and body ground.

**OK: 4.7 V or less**

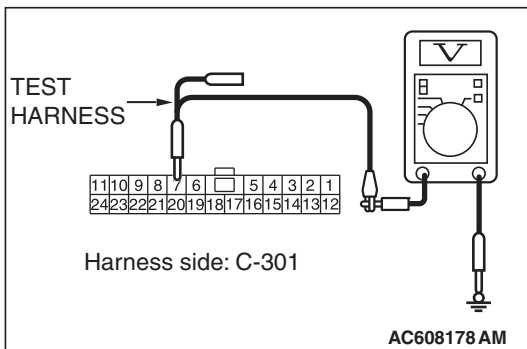
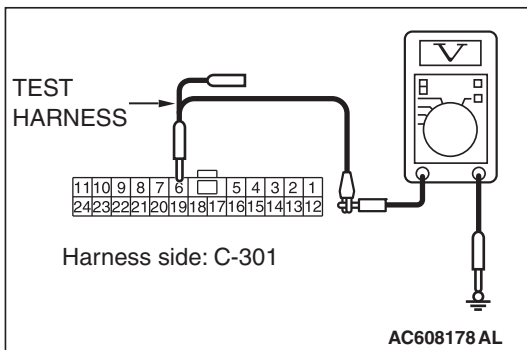

- (4) Measure the voltage between ETACS-ECU connector terminal 7 and body ground.

**OK: 4.7 V or less**

**Q: Do all the voltages measure 4.7 V or less?**

**YES :** Go to Step 2.

**NO :** Go to Step 13.

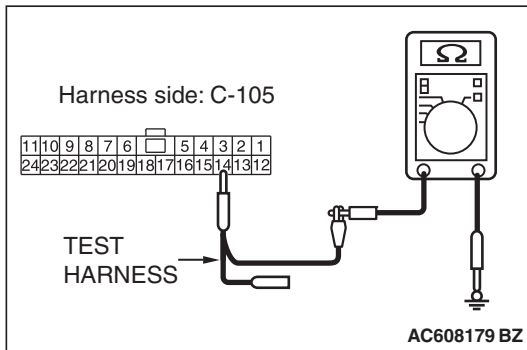
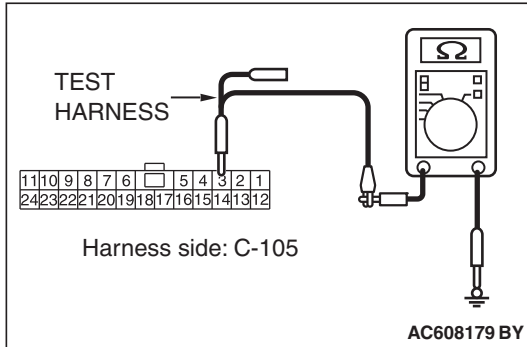

**STEP 2. Check the wiring harness between joint connector (CAN1) C-105 and combination meter connector C-04 for a short to ground. Measure the resistance at joint connector (CAN1) C-105.**

- (1) Disconnect joint connector (CAN1), and measure the resistance at the wiring harness side of joint connector (CAN1).
- (2) Measure the resistance between joint connector (CAN1) terminal 3 and body ground.

**OK: 1 k $\Omega$  or more**

- (3) Measure the resistance between joint connector (CAN1) terminal 14 and body ground.

**OK: 1 k $\Omega$  or more**

**Q: Do all the resistances measure 1 k $\Omega$  or more?**

**YES <vehicles with KOS> : Go to Step 3.**

**YES <vehicles with WCM> : Go to Step 4.**

**NO (vehicles with KOS or WCM) : Go to Step 24.**

**STEP 3. Check the wiring harness between joint connector (CAN1) C-105 and KOS-ECU connector C-05 for a short to ground. Measure the resistance at joint connector (CAN1) C-105.**

- (1) Disconnect joint connector (CAN1), and measure the resistance at the wiring harness side of joint connector (CAN1).
- (2) Measure the resistance between joint connector (CAN1) terminal 9 and body ground.

**OK: 1 k $\Omega$  or more**

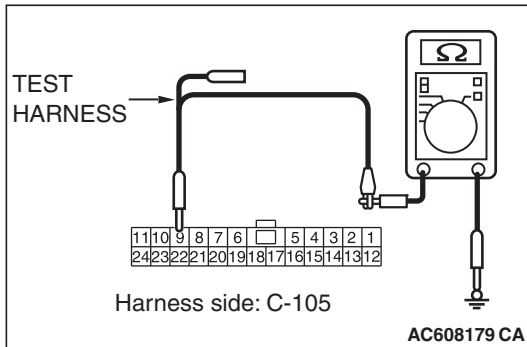

- (3) Measure the resistance between joint connector (CAN1) terminal 22 and body ground.

**OK: 1 k $\Omega$  or more**

**Q: Do all the resistances measure 1 k $\Omega$  or more?**

**YES :** Go to Step 5.

**NO :** Go to Step 25.

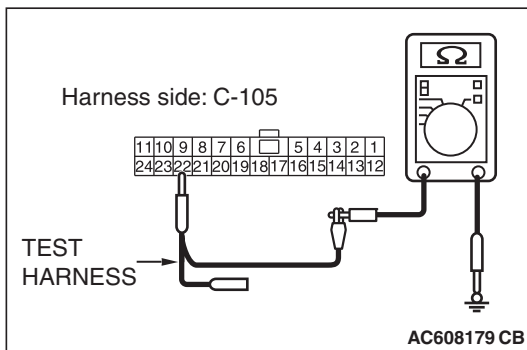

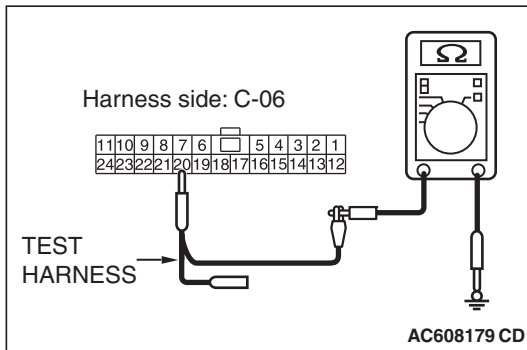
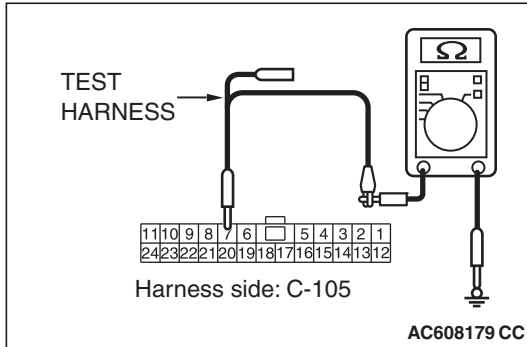

**STEP 4. Check the wiring harness between joint connector (CAN1) C-105 and WCM connector C-07 for a short to ground. Measure the resistance at joint connector (CAN1) C-105.**

- (1) Disconnect joint connector (CAN1), and measure the resistance at the wiring harness side of joint connector (CAN1).
- (2) Measure the resistance between joint connector (CAN1) terminal 7 and body ground.

**OK: 1 k $\Omega$  or more**

- (3) Measure the resistance between joint connector (CAN1) terminal 20 and body ground.

**OK: 1 k $\Omega$  or more**

**Q: Do all the resistances measure 1 k $\Omega$  or more?**

**YES :** Go to Step 5.

**NO :** Go to Step 26.

**STEP 5. Check the wiring harness between joint connector (CAN1) C-105 and SRS-ECU connector C-37 for a short to ground. Measure the resistance at joint connector (CAN1) C-105.**

- (1) Disconnect joint connector (CAN1), and measure the resistance at the wiring harness side of joint connector (CAN1).
- (2) Measure the resistance between joint connector (CAN1) terminal 8 and body ground.

**OK: 1 k $\Omega$  or more**

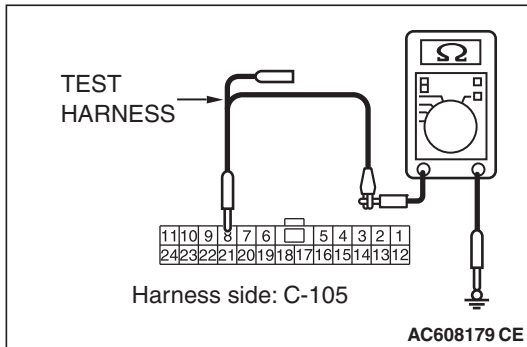

- (3) Measure the resistance between joint connector (CAN1) terminal 21 and body ground.

**OK: 1 k $\Omega$  or more**

**Q: Do all the resistances measure 1 k $\Omega$  or more?**

**YES :** Go to Step 6.

**NO :** Go to Step 27.

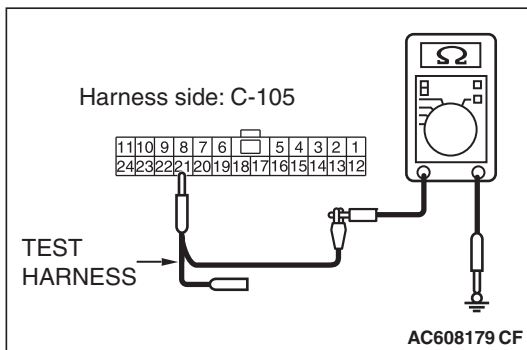

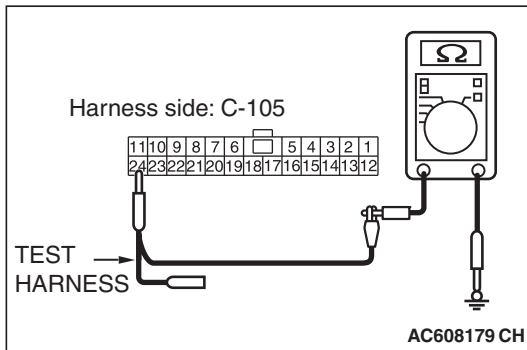
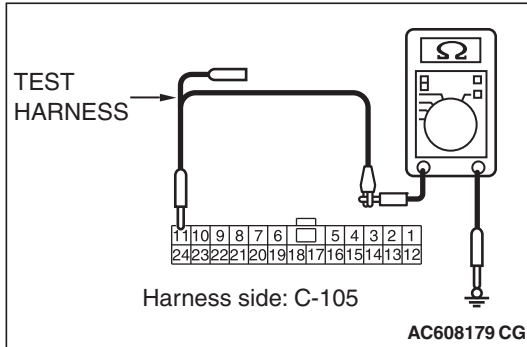

**STEP 6. Check the wiring harness between joint connector (CAN1) C-105 and occupant classification-ECU connector D-39-2 for a short to ground. Measure the resistance at joint connector (CAN1) C-105.**

- (1) Disconnect joint connector (CAN1), and measure the resistance at the wiring harness side of joint connector (CAN1).
- (2) Measure the resistance between joint connector (CAN1) terminal 11 and body ground.

**OK: 1 kΩ or more**

- (3) Measure the resistance between joint connector (CAN1) terminal 24 and body ground.

**OK: 1 kΩ or more**

**Q: Do all the resistances measure 1 kΩ or more?**

**YES (vehicles without hands free system) :** Go to Step 8.

**YES (vehicles with hands free system) :** Go to Step 7.

**NO :** Go to Step 28.

**STEP 7. Check the wiring harness between joint connector (CAN1) C-105 and hands free module connector C-11 for a short to ground. Measure the resistance at joint connector (CAN1) C-105.**

- (1) Disconnect joint connector (CAN1), and measure the resistance at the wiring harness side of joint connector (CAN1).
- (2) Measure the resistance between joint connector (CAN1) terminal 10 and body ground.

**OK: 1 k $\Omega$  or more**

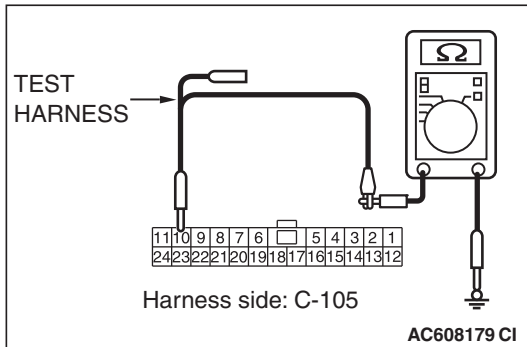

- (3) Measure the resistance between joint connector (CAN1) terminal 23 and body ground.

**OK: 1 k $\Omega$  or more**

**Q: Do all the resistances measure 1 k $\Omega$  or more?**

**YES :** Go to Step 8.

**NO :** Go to Step 29.

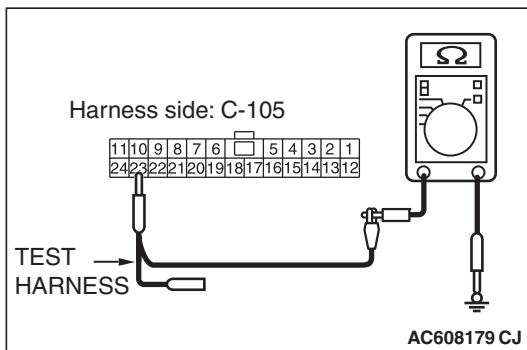

**STEP 8. Check the wiring harness between joint connector (CAN1) C-105 and A/C-ECU connector C-22 <vehicles with A/C> or heater control unit connector C-53 <vehicles without A/C> for a short to ground. Measure the resistance at joint connector (CAN1) C-105.**

- (1) Disconnect joint connector (CAN1), and measure the resistance at the wiring harness side of joint connector (CAN1).
- (2) Measure the resistance between joint connector (CAN1) terminal 1 and body ground.

**OK: 1 k $\Omega$  or more**

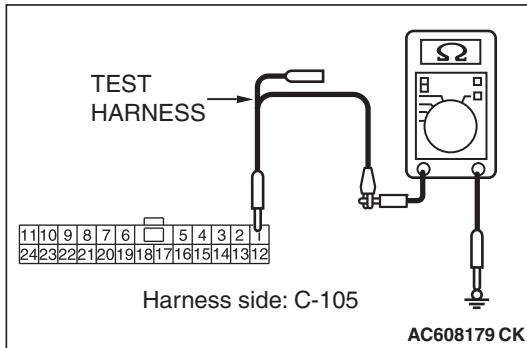

- (3) Measure the resistance between joint connector (CAN1) terminal 12 and body ground.

**OK: 1 k $\Omega$  or more**

**Q: Do all the resistances measure 1 k $\Omega$  or more?**

**YES (vehicles without MMCS) :** Go to Step 9.

**YES (vehicles with MMCS) :** Go to Step 10.

**NO :** Go to Step 30.

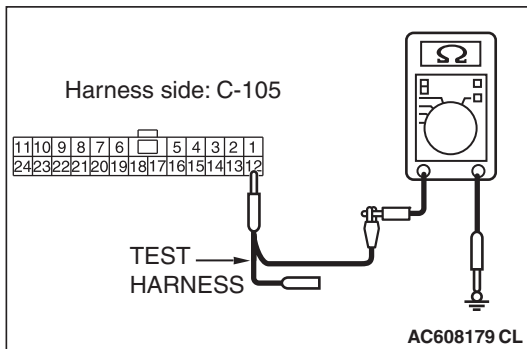



**STEP 9. Check the wiring harness between joint connector (CAN1) C-105 and radio and CD player or CD changer connector C-107 for a short to ground. Measure the resistance at joint connector (CAN1) C-105.**

- (1) Disconnect joint connector (CAN1), and measure the resistance at the wiring harness side of joint connector (CAN1).
- (2) Measure the resistance between joint connector (CAN1) terminal 5 and body ground.

**OK: 1 k $\Omega$  or more**

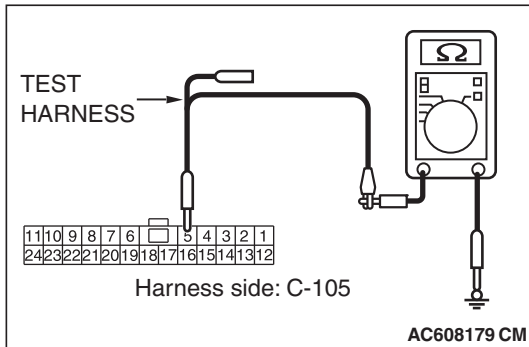

- (3) Measure the resistance between joint connector (CAN1) terminal 16 and body ground.

**OK: 1 k $\Omega$  or more**

**Q: Do all the resistances measure 1 k $\Omega$  or more?**

**YES <vehicles without satellite radio> : Go to Step 12.**

**YES <vehicles with satellite radio> : Go to Step 11.**

**NO : Go to Step 31.**

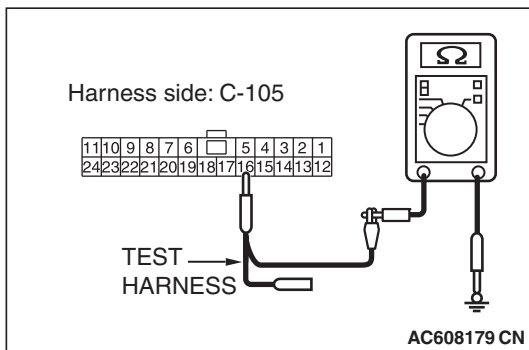

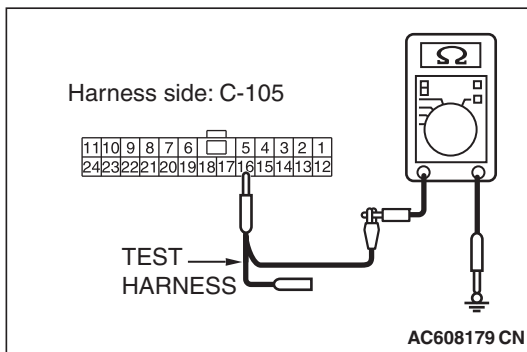
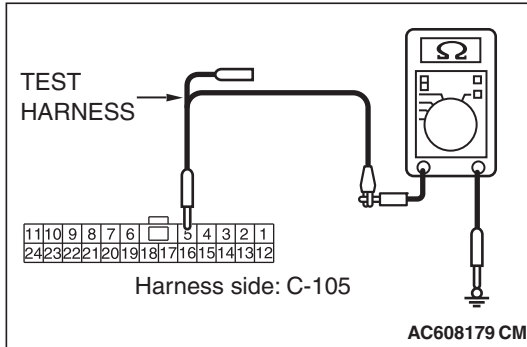

**STEP 10. Check the wiring harness between joint connector (CAN1) C-105 and CAN box unit connector C-15 for a short to ground. Measure the resistance at joint connector (CAN1) C-105.**

- (1) Disconnect joint connector (CAN1), and measure the resistance at the wiring harness side of joint connector (CAN1).
- (2) Measure the resistance between joint connector (CAN1) terminal 5 and body ground.

**OK: 1 k $\Omega$  or more**

- (3) Measure the resistance between joint connector (CAN1) terminal 16 and body ground.

**OK: 1 k $\Omega$  or more**

**Q: Do all the resistances measure 1 k $\Omega$  or more?**

**YES (vehicles without satellite radio) :** Go to Step 12.

**YES (vehicles with satellite radio) :** Go to Step 11.

**NO :** Go to Step 32.

**STEP 11. Check the wiring harness between joint connector (CAN1) C-105 and satellite radio tuner connector C-18 for a short to ground. Measure the resistance at joint connector (CAN1) C-105.**

- (1) Disconnect joint connector (CAN1), and measure the resistance at the wiring harness side of joint connector (CAN1).
- (2) Measure the resistance between joint connector (CAN1) terminal 2 and body ground.

**OK: 1 k $\Omega$  or more**

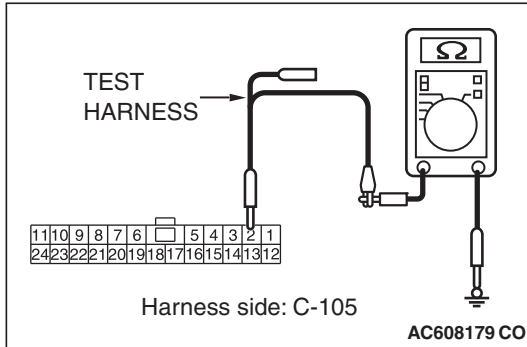

- (3) Measure the resistance between joint connector (CAN1) terminal 13 and body ground.

**OK: 1 k $\Omega$  or more**

**Q: Do all the resistances measure 1 k $\Omega$  or more?**

**YES :** Go to Step 12.

**NO :** Go to Step 33.

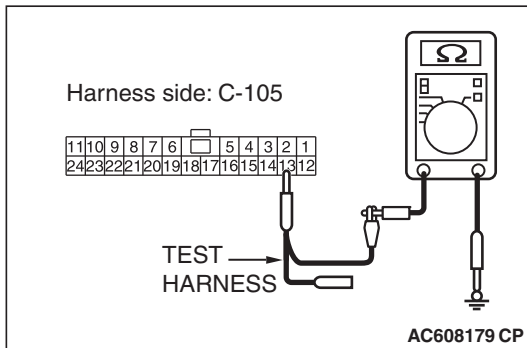

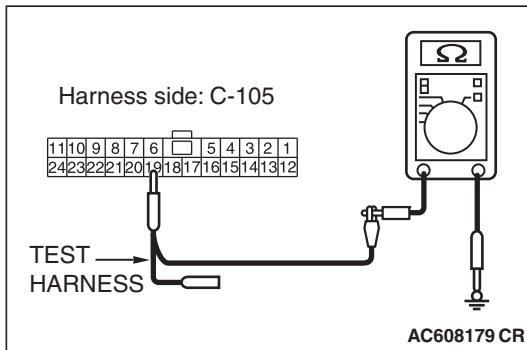
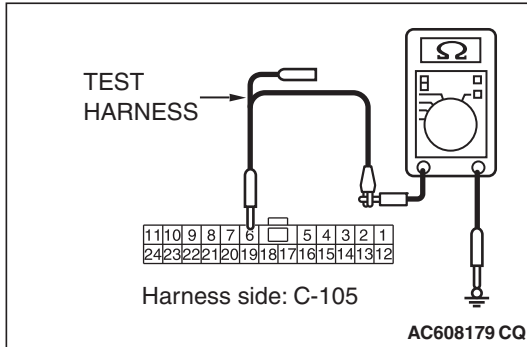

**STEP 12. Check the wiring harness between joint connector (CAN1) C-105 and ETACS-ECU connector C-301 for a short to ground. Measure the resistance at joint connector (CAN1) C-105.**

- (1) Disconnect joint connector (CAN1) and ETACS-ECU connector C-301, and measure the resistance at the wiring harness side of joint connector (CAN1).
- (2) Measure the resistance between joint connector (CAN1) terminal 6 and body ground.

**OK: 1 kΩ or more**

- (3) Measure the resistance between joint connector (CAN1) terminal 19 and body ground.

**OK: 1 kΩ or more**

**Q: Do all the resistances measure 1 kΩ or more?**

**YES :** Go to Step 34.

**NO :** Repair the wiring harness between joint connector (CAN1) C-105 and ETACS-ECU connector C-301.

**STEP 13. Check the wiring harness between joint connector (CAN1) C-105 and combination meter connector C-04 for a short to power supply. Measure the voltage at joint connector (CAN1) C-105.**

**⚠ CAUTION**

A digital multimeter should be used. For details refer to [P.54C-7](#).

**⚠ CAUTION**

The test wiring harness should be used. For details refer to [P.54C-7](#).

- (1) Disconnect joint connector (CAN1), and measure the voltage at the wiring harness side of joint connector (CAN1).
- (2) Turn the ignition switch to the ON position.
- (3) Measure the voltage between joint connector (CAN1) terminal 3 and body ground.

**OK: 4.7 V or less**

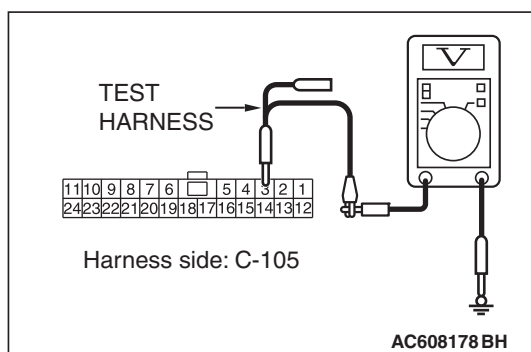

- (4) Measure the voltage between joint connector (CAN1) terminal 14 and body ground.

**OK: 4.7 V or less**

**Q: Do all the voltages measure 4.7 V or less?**

**YES (vehicles with KOS) :** Go to Step 14.

**YES (vehicles with WCM) :** Go to Step 15.

**NO (vehicles with KOS and WCM) :** Go to Step 24.

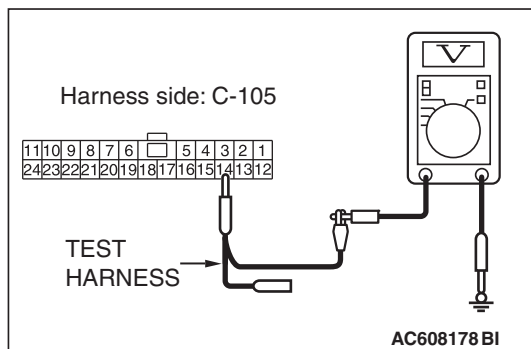

**STEP 14.** Check the wiring harness between joint connector (CAN1) C-105 and KOS-ECU connector C-05 for a short to power supply. Measure the voltage at joint connector (CAN1) C-105.

**⚠ CAUTION**

A digital multimeter should be used. For details refer to [P.54C-7](#).

**⚠ CAUTION**

The test wiring harness should be used. For details refer to [P.54C-7](#).

- (1) Disconnect joint connector (CAN1), and measure the voltage at the wiring harness side of joint connector (CAN1).
- (2) Turn the ignition switch to the ON position.
- (3) Measure the voltage between joint connector (CAN1) terminal 9 and body ground.

**OK: 4.7 V or less**

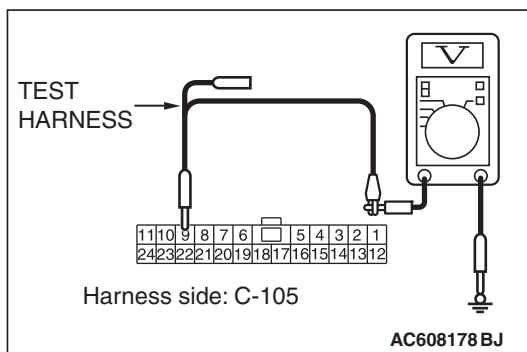

- (4) Measure the voltage between joint connector (CAN1) terminal 22 and body ground.

**OK: 4.7 V or less**

**Q: Do all the voltages measure 4.7 V or less?**

**YES :** Go to Step 16.

**NO :** Go to Step 25.

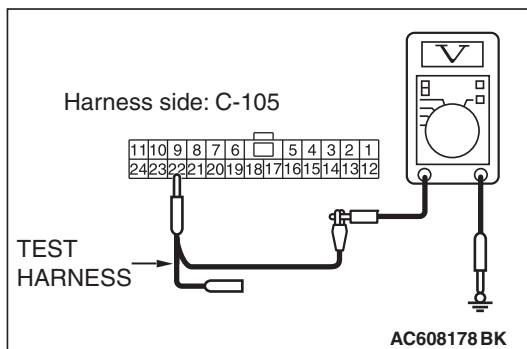

**STEP 15.** Check the wiring harness between joint connector (CAN1) C-105 and WCM connector C-07 for a short to power supply. Measure the voltage at joint connector (CAN1) C-105.

**⚠ CAUTION**

A digital multimeter should be used. For details refer to [P.54C-7](#).

**⚠ CAUTION**

The test wiring harness should be used. For details refer to [P.54C-7](#).

- (1) Disconnect joint connector (CAN1), and measure the voltage at the wiring harness side of joint connector (CAN1).
- (2) Turn the ignition switch to the ON position.
- (3) Measure the voltage between joint connector (CAN1) terminal 7 and body ground.

**OK: 4.7 V or less**

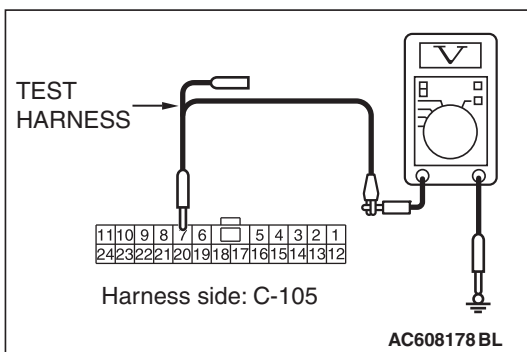

- (4) Measure the voltage between joint connector (CAN1) terminal 20 and body ground.

**OK: 4.7 V or less**

**Q: Do all the voltages measure 4.7 V or less?**

**YES :** Go to Step 16.

**NO :** Go to Step 26.

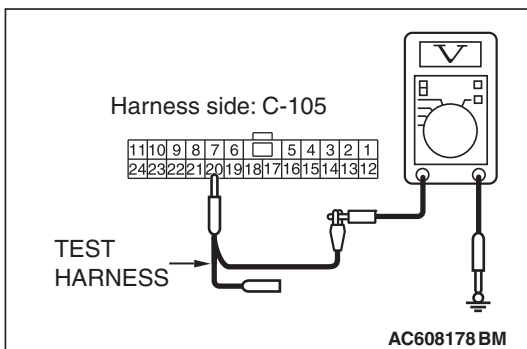

**STEP 16.** Check the wiring harness between joint connector (CAN1) C-105 and SRS-ECU connector C-37 for a short to power supply. Measure the voltage at joint connector (CAN1) C-105.

**⚠ CAUTION**

A digital multimeter should be used. For details refer to [P.54C-7](#).

**⚠ CAUTION**

The test wiring harness should be used. For details refer to [P.54C-7](#).

- (1) Disconnect joint connector (CAN1), and measure the voltage at the wiring harness side of joint connector (CAN1).
- (2) Turn the ignition switch to the ON position.
- (3) Measure the voltage between joint connector (CAN1) terminal 8 and body ground.

**OK: 4.7 V or less**

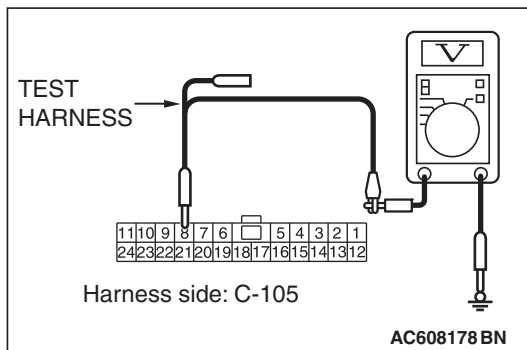

- (4) Measure the voltage between joint connector (CAN1) terminal 21 and body ground.

**OK: 4.7 V or less**

**Q: Do all the voltages measure 4.7 V or less?**

**YES :** Go to Step 17.

**NO :** Go to Step 27.

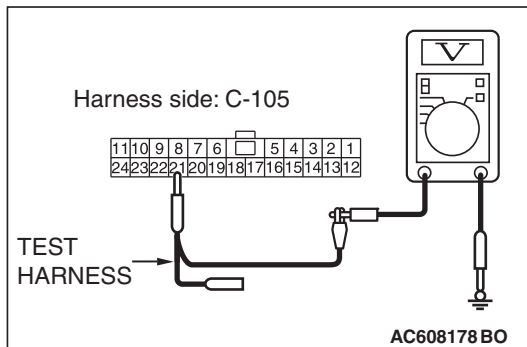



**STEP 17. Check the wiring harness between joint connector (CAN1) C-105 and occupant classification-ECU connector D-39-2 for a short to power supply. Measure the voltage at joint connector (CAN1) C-105.**

**⚠ CAUTION**

A digital multimeter should be used. For details refer to [P.54C-7](#).

**⚠ CAUTION**

The test wiring harness should be used. For details refer to [P.54C-7](#).

- (1) Disconnect joint connector (CAN1), and measure the voltage at the wiring harness side of joint connector (CAN1).
- (2) Turn the ignition switch to the ON position.
- (3) Measure the voltage between joint connector (CAN1) terminal 11 and body ground.

**OK: 4.7 V or less**

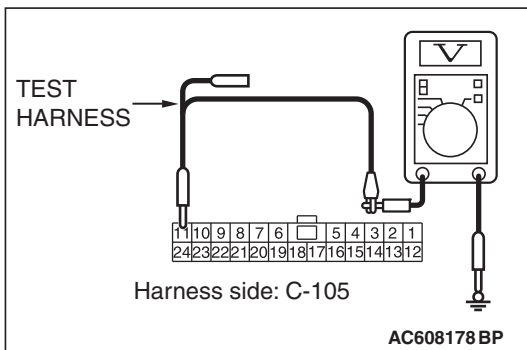

- (4) Measure the voltage between joint connector (CAN1) terminal 24 and body ground.

**OK: 4.7 V or less**

**Q: Do all the voltages measure 4.7 V or less?**

**YES (vehicles without hands free system) :** Go to Step 19.

**YES (vehicles with hands free system) :** Go to Step 18.

**NO :** Go to Step 28.

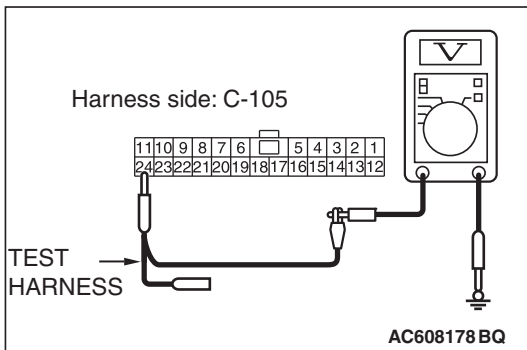

**STEP 18.** Check the wiring harness between joint connector (CAN1) C-105 and hands free module connector C-11 for a short to power supply. Measure the voltage at joint connector (CAN1) C-105.

**⚠ CAUTION**

A digital multimeter should be used. For details refer to [P.54C-7](#).

**⚠ CAUTION**

The test wiring harness should be used. For details refer to [P.54C-7](#).

- (1) Disconnect joint connector (CAN1), and measure the voltage at the wiring harness side of joint connector (CAN1).
- (2) Turn the ignition switch to the ON position.
- (3) Measure the voltage between joint connector (CAN1) terminal 10 and body ground.

**OK: 4.7 V or less**

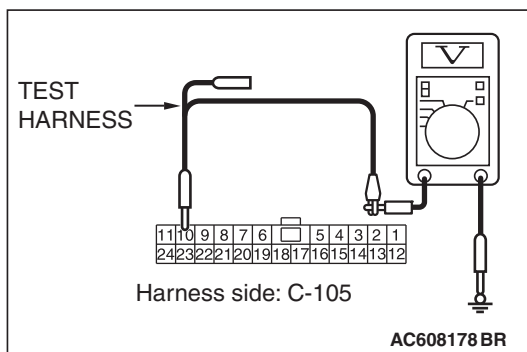

- (4) Measure the voltage between joint connector (CAN1) terminal 23 and body ground.

**OK: 4.7 V or less**

**Q: Do all the voltages measure 4.7 V or less?**

**YES :** Go to Step 19.

**NO :** Go to Step 29.

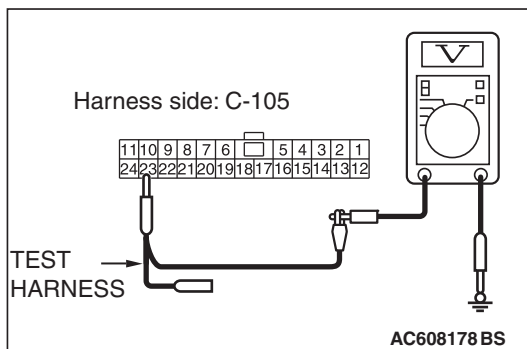

**STEP 19.** Check the wiring harness between joint connector (CAN1) C-105 and A/C-ECU connector C-22 <vehicles with A/C> or heater control unit connector C-53 <vehicles without A/C> for a short to power supply. Measure the voltage at joint connector (CAN1) C-105.

**⚠ CAUTION**

A digital multimeter should be used. For details refer to P.54C-7.

**⚠ CAUTION**

The test wiring harness should be used. For details refer to P.54C-7.

- (1) Disconnect joint connector (CAN1), and measure the voltage at the wiring harness side of joint connector (CAN1).
- (2) Turn the ignition switch to the ON position.
- (3) Measure the voltage between joint connector (CAN1) terminal 1 and body ground.

**OK: 4.7 V or less**

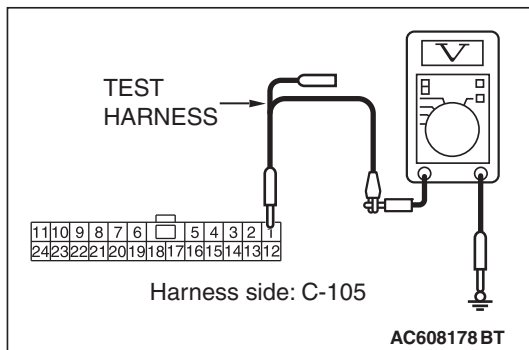

- (4) Measure the voltage between joint connector (CAN1) terminal 12 and body ground.

**OK: 4.7 V or less**

**Q: Do all the voltages measure 4.7 V or less?**

**YES (vehicles without MMCS) :** Go to Step 20.

**YES (vehicles with MMCS) :** Go to Step 21.

**NO :** Go to Step 30.

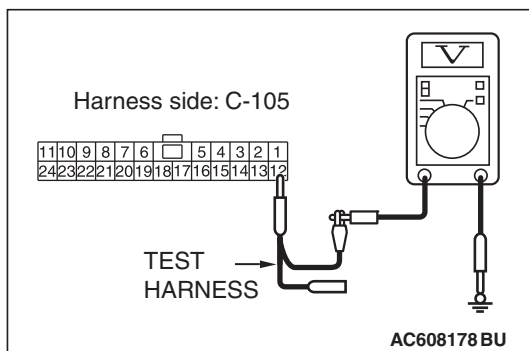

**STEP 20.** Check the wiring harness between joint connector (CAN1) C-105 and radio and CD player or CD changer connector C-107 for a short to power supply. Measure the voltage at joint connector (CAN1) C-105.

**⚠ CAUTION**

A digital multimeter should be used. For details refer to [P.54C-7](#).

**⚠ CAUTION**

The test wiring harness should be used. For details refer to [P.54C-7](#).

- (1) Disconnect joint connector (CAN1), and measure the voltage at the wiring harness side of joint connector (CAN1).
- (2) Turn the ignition switch to the ON position.
- (3) Measure the voltage between joint connector (CAN1) terminal 5 and body ground.

**OK: 4.7 V or less**

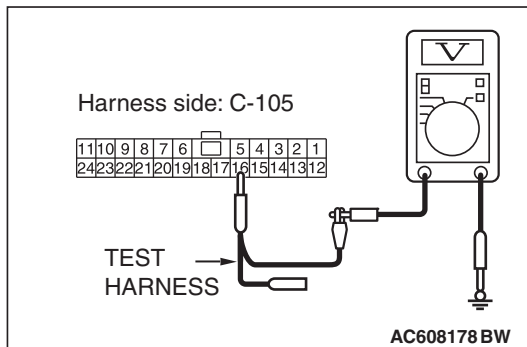
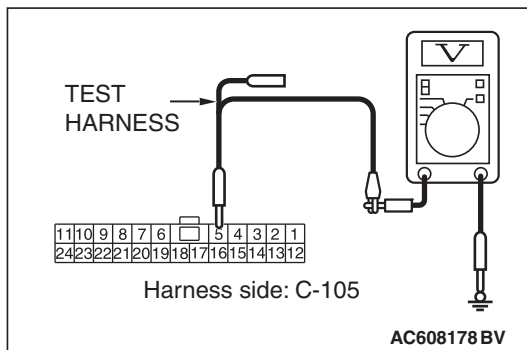

- (4) Measure the voltage between joint connector (CAN1) terminal 16 and body ground.

**OK: 4.7 V or less**

**Q: Do all the voltages measure 4.7 V or less?**

**YES (vehicles without satellite radio) :** Go to Step 23.

**YES (vehicles with satellite radio) :** Go to Step 22.

**NO :** Go to Step 31.

**STEP 21. Check the wiring harness between joint connector (CAN1) C-105 and CAN box unit connector C-15 for a short to power supply. Measure the voltage at joint connector (CAN1) C-105.**

**⚠ CAUTION**

A digital multimeter should be used. For details refer to [P.54C-7](#).

**⚠ CAUTION**

The test wiring harness should be used. For details refer to [P.54C-7](#).

- (1) Disconnect joint connector (CAN1), and measure the voltage at the wiring harness side of joint connector (CAN1).
- (2) Turn the ignition switch to the ON position.
- (3) Measure the voltage between joint connector (CAN1) terminal 5 and body ground.

**OK: 4.7 V or less**

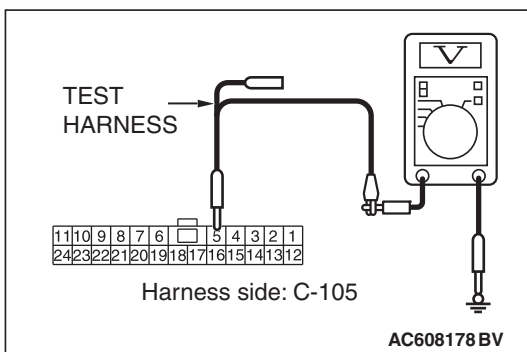

- (4) Measure the voltage between joint connector (CAN1) terminal 16 and body ground.

**OK: 4.7 V or less**

**Q: Do all the voltages measure 4.7 V or less?**

**YES (vehicles without satellite radio) :** Go to Step 23.

**YES (vehicles with satellite radio) :** Go to Step 22.

**NO :** Go to Step 32.

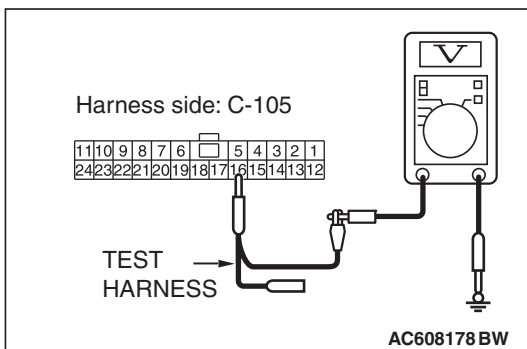

**STEP 22. Check the wiring harness between joint connector (CAN1) C-105 and satellite radio tuner connector C-18 for a short to power supply. Measure the voltage at joint connector (CAN1) C-105.**

**⚠ CAUTION**

A digital multimeter should be used. For details refer to [P.54C-7](#).

**⚠ CAUTION**

The test wiring harness should be used. For details refer to [P.54C-7](#).

- (1) Disconnect joint connector (CAN1), and measure the voltage at the wiring harness side of joint connector (CAN1).
- (2) Turn the ignition switch to the ON position.
- (3) Measure the voltage between joint connector (CAN1) terminal 2 and body ground.

**OK: 4.7 V or less**

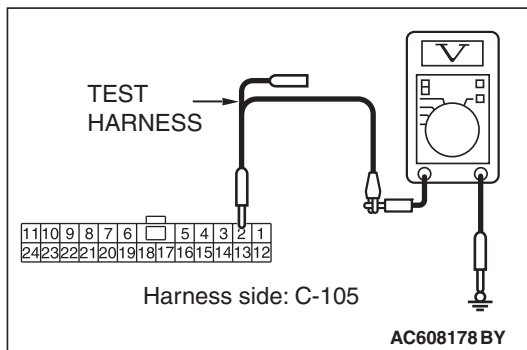

- (4) Measure the voltage between joint connector (CAN1) terminal 13 and body ground.

**OK: 4.7 V or less**

**Q: Do all the voltages measure 4.7 V or less?**

**YES :** Go to Step 23.

**NO :** Go to Step 33.

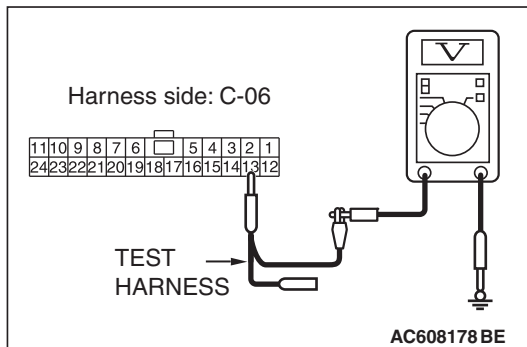

**STEP 23. Check the wiring harness between joint connector (CAN1) C-105 and ETACS-ECU connector C-301 for a short to power supply. Measure the voltage at joint connector (CAN1) C-105.**

**⚠ CAUTION**

A digital multimeter should be used. For details refer to [P.54C-7](#).

**⚠ CAUTION**

The test wiring harness should be used. For details refer to [P.54C-7](#).

- (1) Disconnect joint connector (CAN1) and ETACS-ECU connector C-301, and measure the voltage at the wiring harness side of joint connector (CAN1).
- (2) Turn the ignition switch to the ON position.
- (3) Measure the voltage between joint connector (CAN1) terminal 6 and body ground.

**OK: 1 V or less**

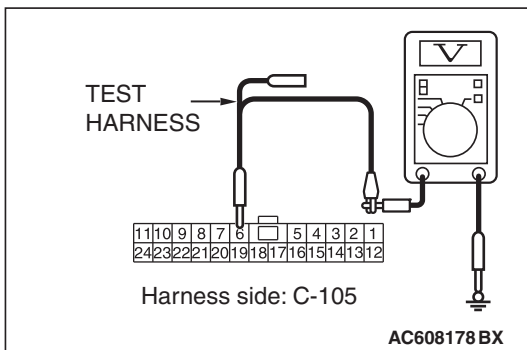

- (4) Measure the voltage between joint connector (CAN1) terminal 19 and body ground.

**OK: 1 V or less**

**Q: Do all the voltages measure 1 V or less?**

**YES :** Go to Step 34.

**NO :** Repair the wiring harness between joint connector (CAN1) C-105 and ETACS-ECU connector C-301.

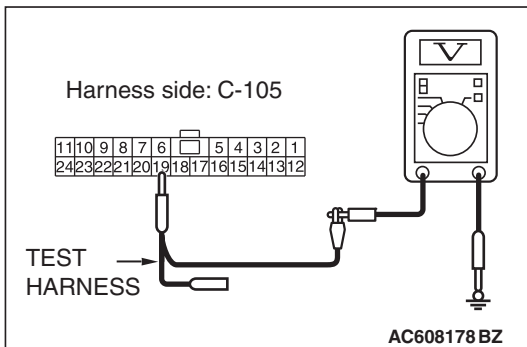

**STEP 24.** Using scan tool MB991958, diagnose the CAN bus line. (checking the combination meter for internal failure)

**⚠ CAUTION**

Strictly observe the specified wiring harness repair procedure. For details refer to [P.54C-7](#).

**⚠ CAUTION**

To prevent damage to scan tool MB991958, always turn the ignition switch to the "LOCK" (OFF) position before connecting or disconnecting scan tool MB991958.

- (1) Disconnect combination meter connector C-04.
- (2) Connect scan tool MB991958 to the data link connector.
- (3) Turn the ignition switch to the "ON" position.

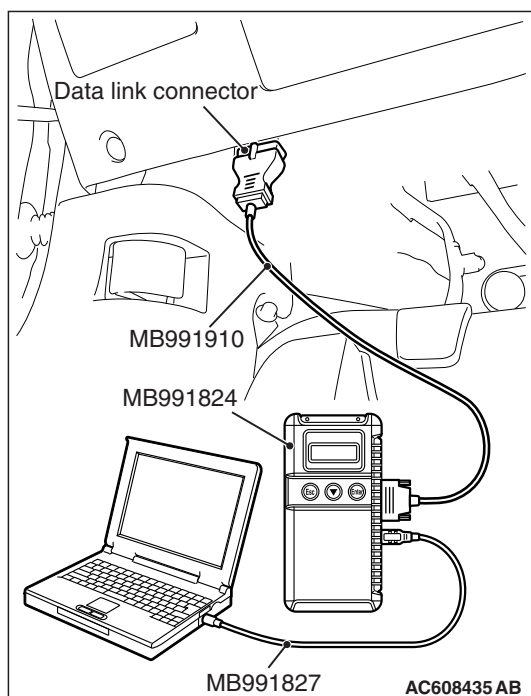



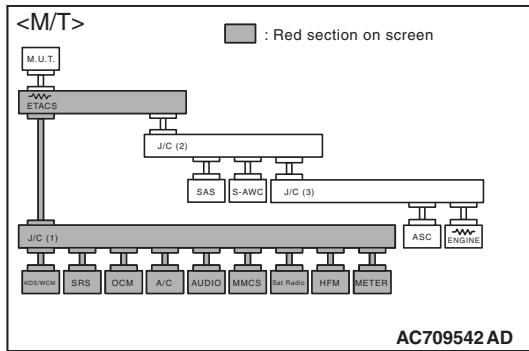

(4) Diagnose CAN bus lines, and check if the scan tool MB991958 screen is as shown in the figure.

**OK:** The display of the scan tool MB991958 is as shown in the figure.

**Q:** Does scan tool MB991958 screen correspond to the illustration?

**YES :** Repair the wiring harness between joint connector (CAN1) C-105 and combination meter connector C-04.

**NO :** Check combination meter connector C-04, and repair if necessary. If the combination meter connector is in good condition, replace the combination meter.

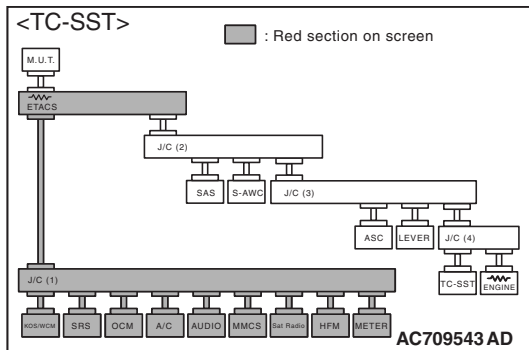

**STEP 25.** Using scan tool MB991958, diagnose the CAN bus line. (checking the KOS-ECU for internal failure)

**⚠ CAUTION**

Strictly observe the specified wiring harness repair procedure. For details refer to [P.54C-7](#).

**⚠ CAUTION**

To prevent damage to scan tool MB991958, always turn the ignition switch to the "LOCK" (OFF) position before connecting or disconnecting scan tool MB991958.

- (1) Disconnect KOS-ECU connector C-05.
- (2) Connect scan tool MB991958 to the data link connector.
- (3) Turn the ignition switch to the "ON" position.

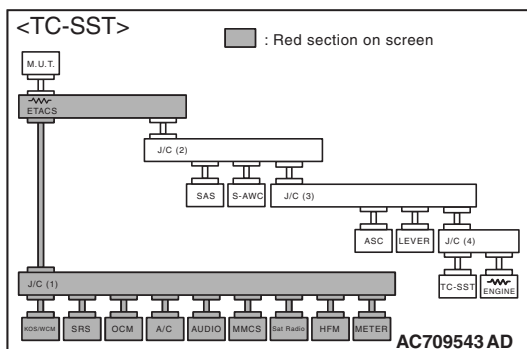
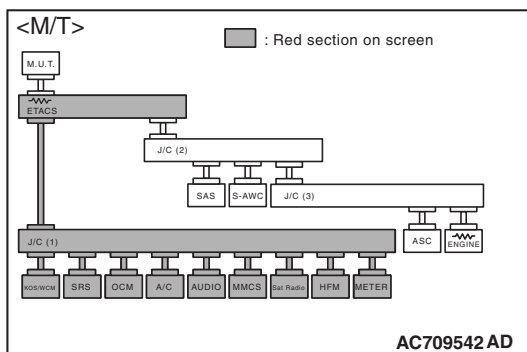
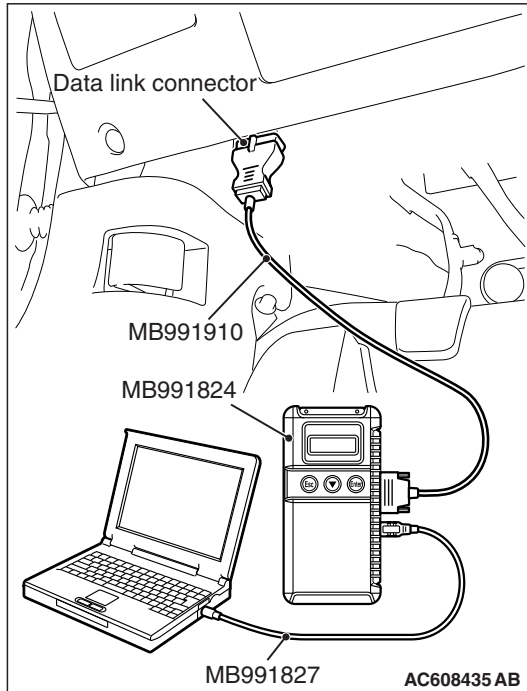

- (4) Diagnose CAN bus lines, and check if the scan tool MB991958 screen is as shown in the figure.

**OK:** The display of the scan tool MB991958 is as shown in the figure.

**Q:** Does scan tool MB991958 screen correspond to the illustration?

**YES :** Repair the wiring harness between joint connector (CAN1) C-105 and KOS-ECU connector C-05.

**NO :** Check KOS-ECU connector C-05, and repair if necessary. If the KOS-ECU connector is in good condition, replace the KOS-ECU.

**STEP 26.** Using scan tool MB991958, diagnose the CAN bus line. (checking the WCM for internal failure)

**CAUTION**

Strictly observe the specified wiring harness repair procedure. For details refer to [P.54C-7](#).

**CAUTION**

To prevent damage to scan tool MB991958, always turn the ignition switch to the "LOCK" (OFF) position before connecting or disconnecting scan tool MB991958.

- (1) Disconnect WCM connector C-07.
- (2) Connect scan tool MB991958 to the data link connector.
- (3) Turn the ignition switch to the "ON" position.

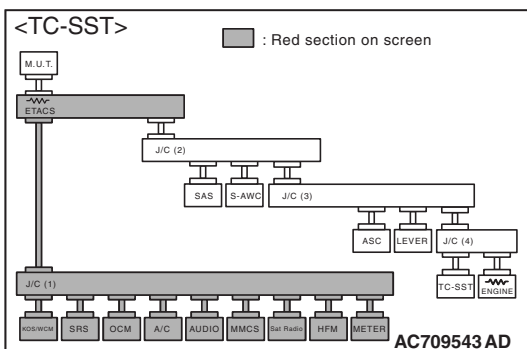
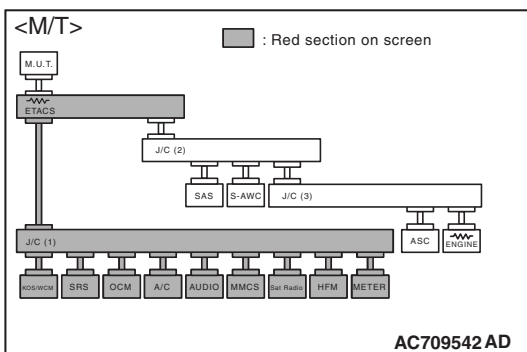
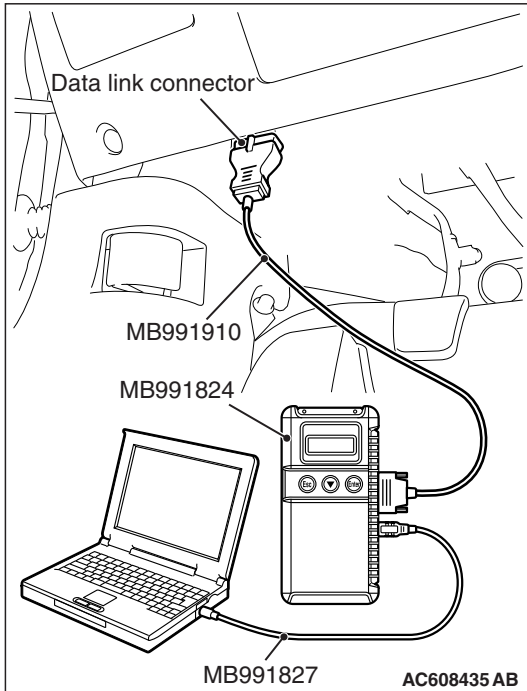

- (4) Diagnose CAN bus lines, and check if the scan tool MB991958 screen is as shown in the figure.

**OK:** The display of the scan tool MB991958 is as shown in the figure.

**Q:** Does scan tool MB991958 screen correspond to the illustration?

**YES :** Repair the wiring harness between joint connector (CAN1) C-105 and WCM connector C-07.

**NO :** Check WCM connector C-07, and repair if necessary. If the WCM connector is in good condition, replace the WCM.

**STEP 27.** Using scan tool MB991958, diagnose the CAN bus line. (checking the SRS-ECU for internal failure)

**⚠ CAUTION**

Strictly observe the specified wiring harness repair procedure. For details refer to [P.54C-7](#).

**⚠ CAUTION**

To prevent damage to scan tool MB991958, always turn the ignition switch to the "LOCK" (OFF) position before connecting or disconnecting scan tool MB991958.

- (1) Disconnect SRS-ECU connector C-37.
- (2) Connect scan tool MB991958 to the data link connector.
- (3) Turn the ignition switch to the "ON" position.

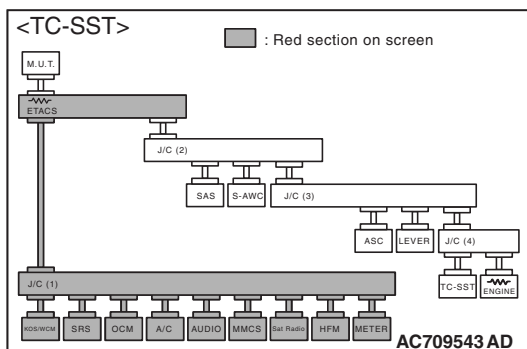
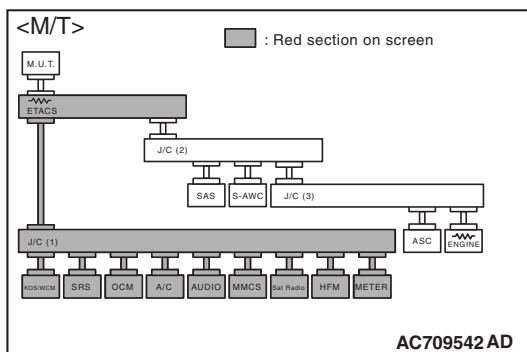
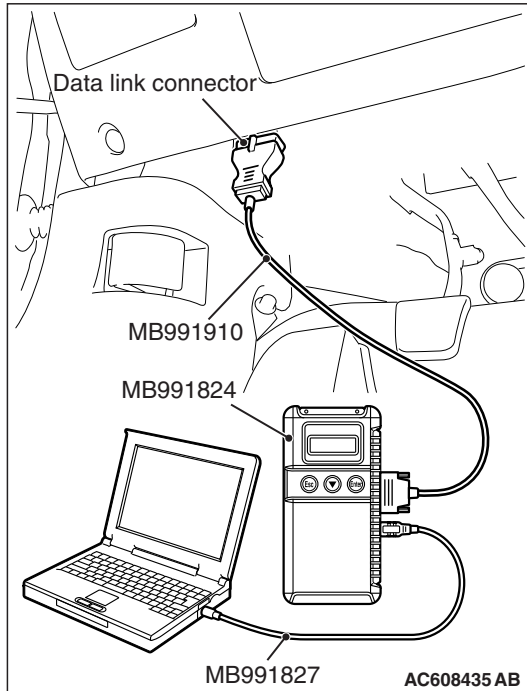

- (4) Diagnose CAN bus lines, and check if the scan tool MB991958 screen is as shown in the figure.

**OK:** The display of the scan tool MB991958 is as shown in the figure.

**Q:** Does scan tool MB991958 screen correspond to the illustration?

**YES :** Repair the wiring harness between joint connector (CAN1) C-105 and SRS-ECU connector C-37.

**NO :** Check SRS-ECU connector C-37, and repair if necessary. If the SRS-ECU connector is in good condition, replace the SRS-ECU.

**STEP 28.** Using scan tool MB991958, diagnose the CAN bus line. (checking the occupant classification-ECU for internal failure)

**⚠ CAUTION**

Strictly observe the specified wiring harness repair procedure. For details refer to [P.54C-7](#).

**⚠ CAUTION**

To prevent damage to scan tool MB991958, always turn the ignition switch to the "LOCK" (OFF) position before connecting or disconnecting scan tool MB991958.

- (1) Disconnect occupant classification-ECU connector D-39-2.
- (2) Connect scan tool MB991958 to the data link connector.
- (3) Turn the ignition switch to the "ON" position.

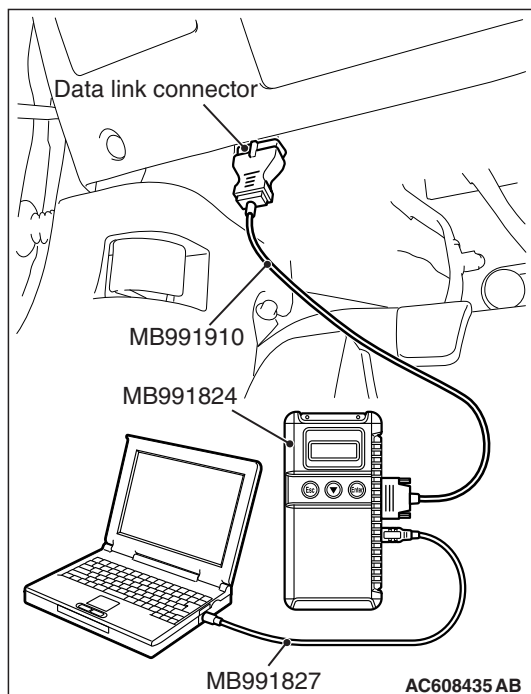

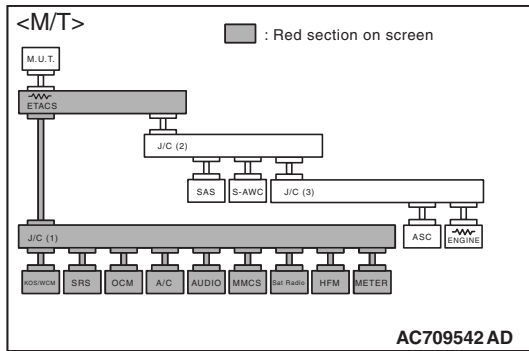

- (4) Diagnose CAN bus lines, and check if the scan tool MB991958 screen is as shown in the figure.

**OK:** The display of the scan tool MB991958 is as shown in the figure.

- Q:** Does scan tool MB991958 screen correspond to the illustration?

**YES :** Repair the wiring harness between joint connector (CAN1) C-105 and occupant classification-ECU connector D-39-2.

**NO :** Check occupant classification-ECU connector D-39-2, and repair if necessary. If the occupant classification-ECU connector is in good condition, replace the occupant classification-ECU.

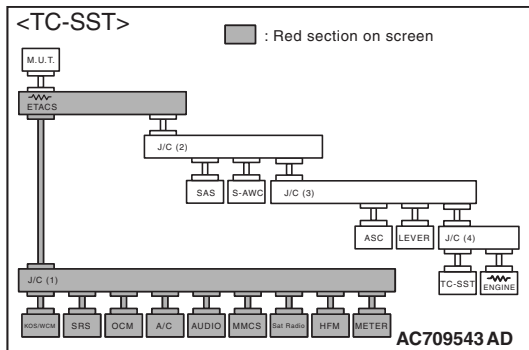

**STEP 29.** Using scan tool MB991958, diagnose the CAN bus line. (checking the hands free module for internal failure)

**⚠ CAUTION**

Strictly observe the specified wiring harness repair procedure. For details refer to [P.54C-7](#).

**⚠ CAUTION**

To prevent damage to scan tool MB991958, always turn the ignition switch to the "LOCK" (OFF) position before connecting or disconnecting scan tool MB991958.

- (1) Disconnect hands free module connector C-11.
- (2) Connect scan tool MB991958 to the data link connector.
- (3) Turn the ignition switch to the "ON" position.

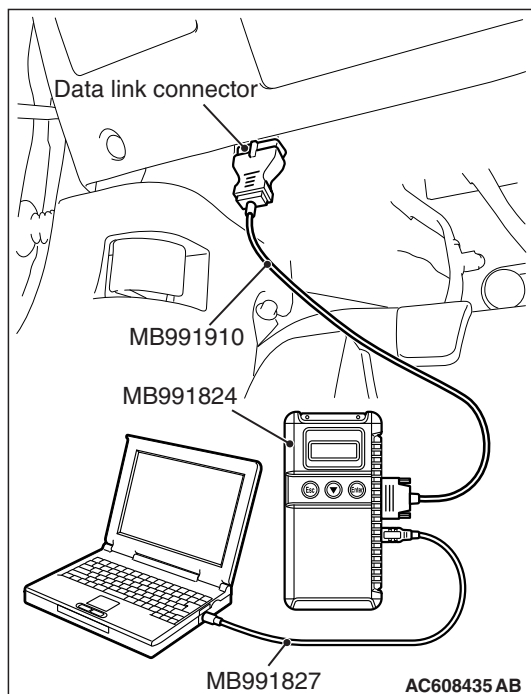

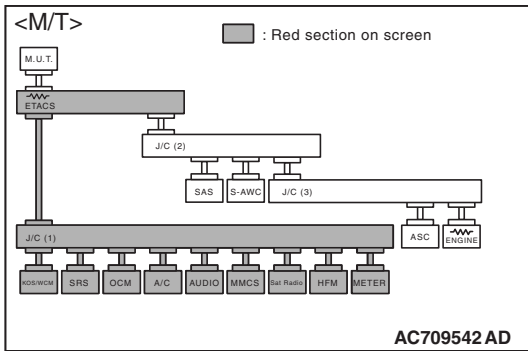

(4) Diagnose CAN bus lines, and check if the scan tool MB991958 screen is as shown in the figure.

**OK:** The display of the scan tool MB991958 is as shown in the figure.

**Q:** Does scan tool MB991958 screen correspond to the illustration?

**YES :** Repair the wiring harness between joint connector (CAN1) C-105 and hands free module connector C-11.

**NO :** Check hands free module connector C-11, and repair if necessary. If the hands free module connector is in good condition, replace the hands free module.

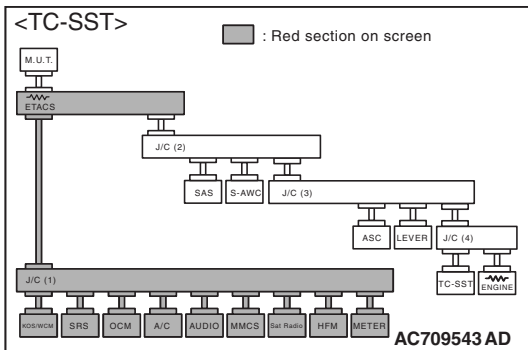



**STEP 30.** Using scan tool MB991958, diagnose the CAN bus line. (checking the A/C-ECU <vehicles with A/C> or heater control unit <vehicles without A/C> for internal failure)

**⚠ CAUTION**

Strictly observe the specified wiring harness repair procedure. For details refer to [P.54C-7](#).

**⚠ CAUTION**

To prevent damage to scan tool MB991958, always turn the ignition switch to the "LOCK" (OFF) position before connecting or disconnecting scan tool MB991958.

- (1) Disconnect A/C-ECU connector C-22 <vehicles with A/C> or heater control unit connector C-53 <vehicles without A/C>.
- (2) Connect scan tool MB991958 to the data link connector.
- (3) Turn the ignition switch to the "ON" position.

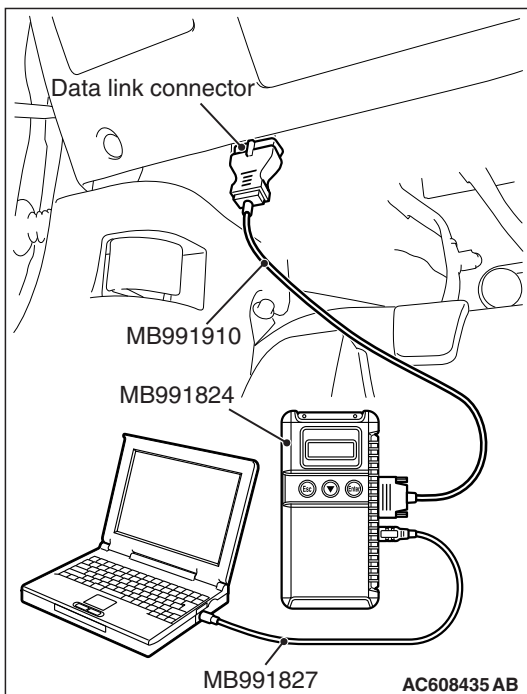

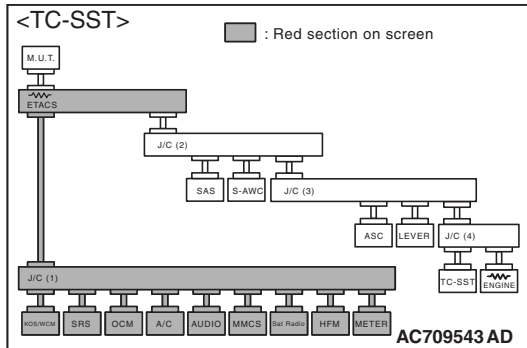
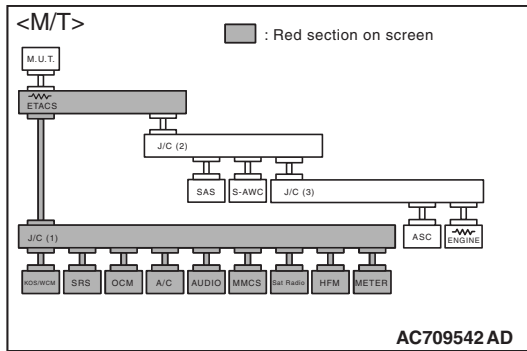

- (4) Diagnose CAN bus lines, and check if the scan tool MB991958 screen is as shown in the figure.

**OK:** The display of the scan tool MB991958 is as shown in the figure.

- Q:** Does scan tool MB991958 screen correspond to the illustration?

**YES :** Repair the wiring harness between joint connector (CAN1) C-105 and A/C-ECU connector C-22 <vehicles with A/C> or heater control unit connector C-53 <vehicles without A/C>.

**NO :** Check A/C-ECU connector C-22 <vehicles with A/C> or heater control unit connector C-53 <vehicles without A/C>, and repair if necessary. If the A/C-ECU connector <vehicles with A/C> or heater control unit connector <vehicles without A/C> is in good condition, replace the A/C-ECU <vehicles with A/C> or heater control unit <vehicles without A/C>.

**STEP 31.** Using scan tool MB991958, diagnose the CAN bus line. (checking the radio and CD player or CD changer for internal failure)

**⚠ CAUTION**

Strictly observe the specified wiring harness repair procedure. For details refer to [P.54C-7](#).

**⚠ CAUTION**

To prevent damage to scan tool MB991958, always turn the ignition switch to the "LOCK" (OFF) position before connecting or disconnecting scan tool MB991958.

- (1) Disconnect radio and CD player or CD changer connector C-107.
- (2) Connect scan tool MB991958 to the data link connector.
- (3) Turn the ignition switch to the "ON" position.

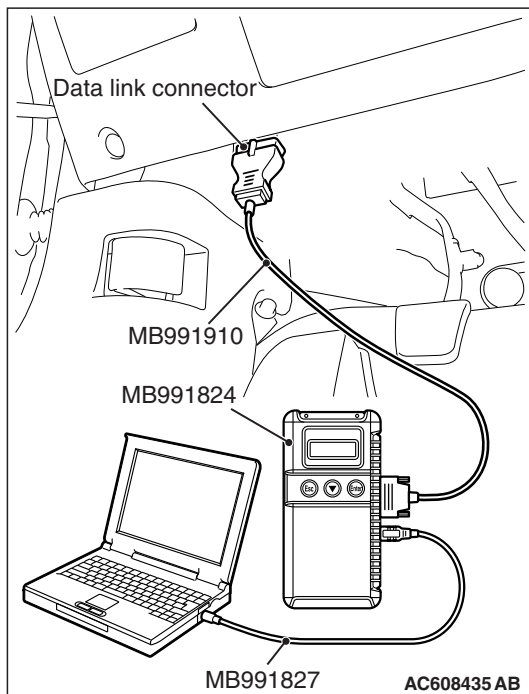

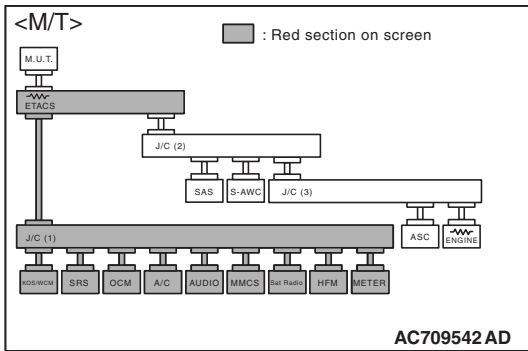

(4) Diagnose CAN bus lines, and check if the scan tool MB991958 screen is as shown in the figure.

**OK:** The display of the scan tool MB991958 is as shown in the figure.

**Q:** Does scan tool MB991958 screen correspond to the illustration?

**YES :** Repair the wiring harness between joint connector (CAN1) C-105 and radio and CD player or CD changer connector C-107.

**NO :** Check radio and CD player or CD changer connector C-107, and repair if necessary. If the radio and CD player or CD changer connector is in good condition, replace the radio and CD player or CD changer.

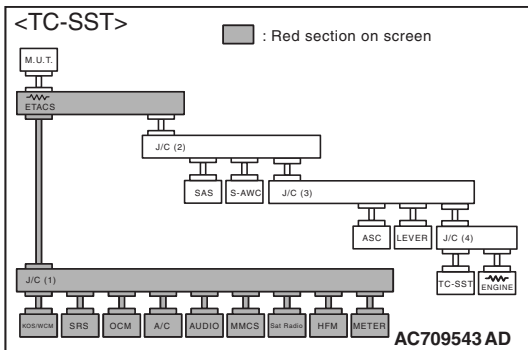

**STEP 32.** Using scan tool MB991958, diagnose the CAN bus line. (checking the CAN box unit for internal failure)

**⚠ CAUTION**

Strictly observe the specified wiring harness repair procedure. For details refer to [P.54C-7](#).

**⚠ CAUTION**

To prevent damage to scan tool MB991958, always turn the ignition switch to the "LOCK" (OFF) position before connecting or disconnecting scan tool MB991958.

- (1) Disconnect CAN box unit connector C-15.
- (2) Connect scan tool MB991958 to the data link connector.
- (3) Turn the ignition switch to the "ON" position.

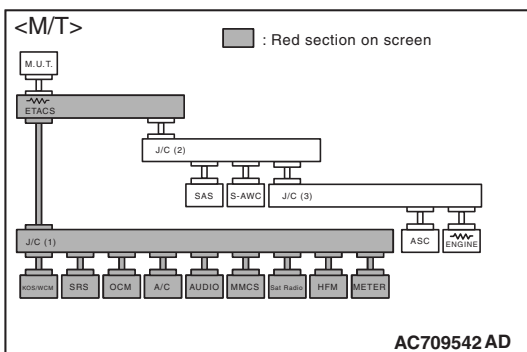
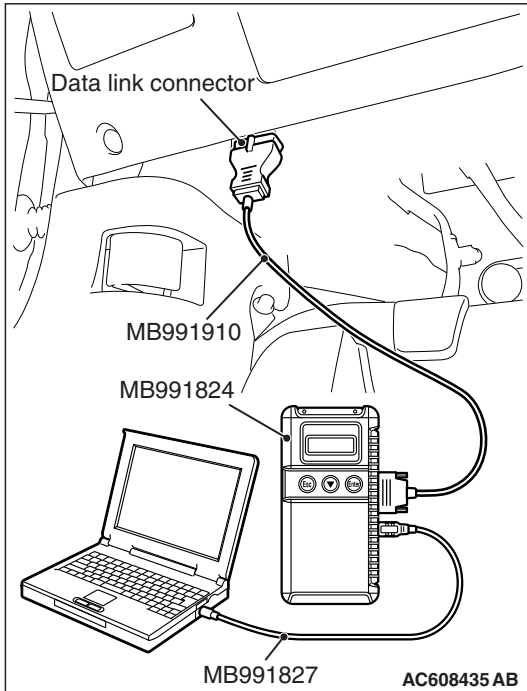

- (4) Diagnose CAN bus lines, and check if the scan tool MB991958 screen is as shown in the figure.

**OK:** The display of the scan tool MB991958 is as shown in the figure.

**Q:** Does scan tool MB991958 screen correspond to the illustration?

**YES :** Repair the wiring harness between joint connector (CAN1) C-105 and CAN box unit connector C-15.

**NO :** Check CAN box unit connector C-15, and repair if necessary. If the CAN box unit connector is in good condition, replace the CAN box unit.

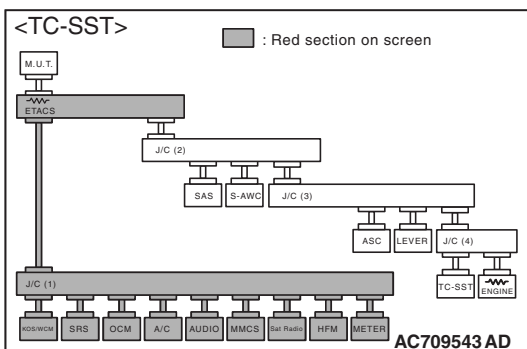

**STEP 33.** Using scan tool MB991958, diagnose the CAN bus line. (checking the satellite radio tuner for internal failure)

**⚠ CAUTION**

Strictly observe the specified wiring harness repair procedure. For details refer to [P.54C-7](#).

**⚠ CAUTION**

To prevent damage to scan tool MB991958, always turn the ignition switch to the "LOCK" (OFF) position before connecting or disconnecting scan tool MB991958.

- (1) Disconnect satellite radio tuner connector C-18.
- (2) Connect scan tool MB991958 to the data link connector.
- (3) Turn the ignition switch to the "ON" position.

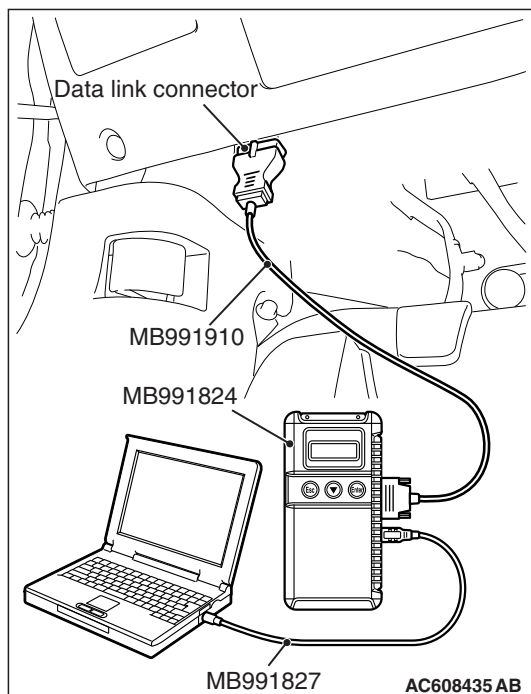

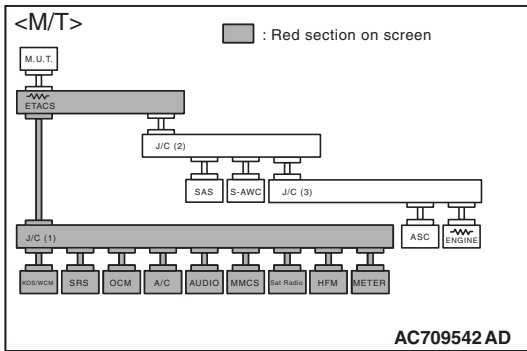

(4) Diagnose CAN bus lines, and check if the scan tool MB991958 screen is as shown in the figure.

**OK:** The display of the scan tool MB991958 is as shown in the figure.

**Q:** Does scan tool MB991958 screen correspond to the illustration?

**YES :** Repair the wiring harness between joint connector (CAN1) C-105 and satellite radio tuner connector C-18.

**NO :** Check satellite radio tuner connector C-18, and repair if necessary. If the satellite radio tuner connector is in good condition, replace the satellite radio tuner.

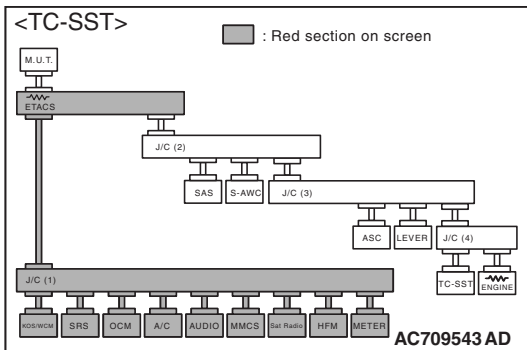

**STEP 34. Using scan tool MB991958, diagnose the CAN bus line. (trouble symptom check)**

**⚠ CAUTION**

Strictly observe the specified wiring harness repair procedure. For details refer to [P.54C-7](#).

**⚠ CAUTION**

To prevent damage to scan tool MB991958, always turn the ignition switch to the "LOCK" (OFF) position before connecting or disconnecting scan tool MB991958.

- (1) Connect scan tool MB991958 to the data link connector.
- (2) Turn the ignition switch to the "ON" position.

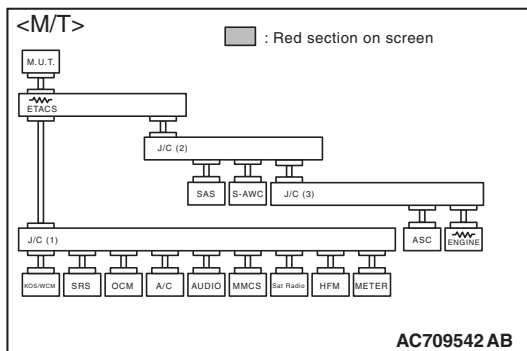
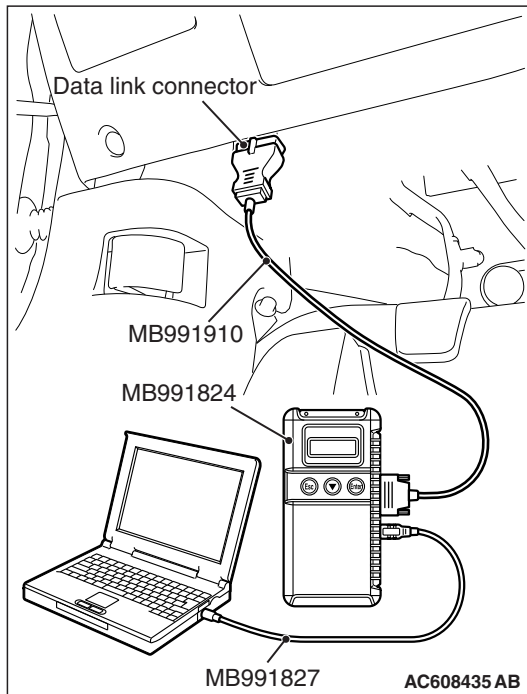

- (3) Diagnose CAN bus lines, and check if the scan tool MB991958 screen is as shown in the figure.

**OK: The display of the scan tool MB991958 is as shown in the figure.**

**Q: Does scan tool MB991958 screen correspond to the illustration?**

**YES :** The trouble can be an intermittent malfunction (Refer to GROUP 00, How to use Troubleshooting/inspection Service Points –How to Cope with Intermittent Malfunction [P.00-15](#)).

**NO :** Check the ETACS-ECU connector C-301, and repair if necessary. If the ETACS-ECU connector is in good condition, replace the ETACS-ECU.

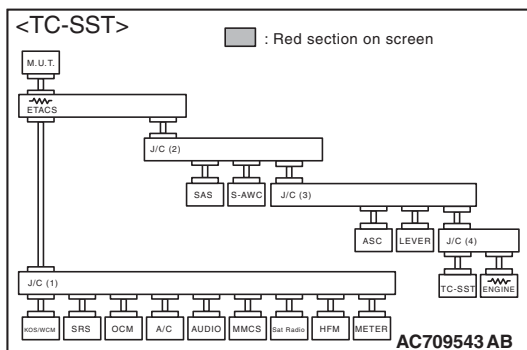



**DIAGNOSTIC ITEM 26: Diagnose the ETACS-ECU, joint connector (CAN1) or lines between ETACS-ECU and joint connector (CAN1).**

**CAUTION**

When servicing a CAN bus line, ground yourself by touching a metal object such as an unpainted water pipe. If you fail to do so, a component connected to the CAN bus line may be damaged.

**CAN-B Communication Circuit**

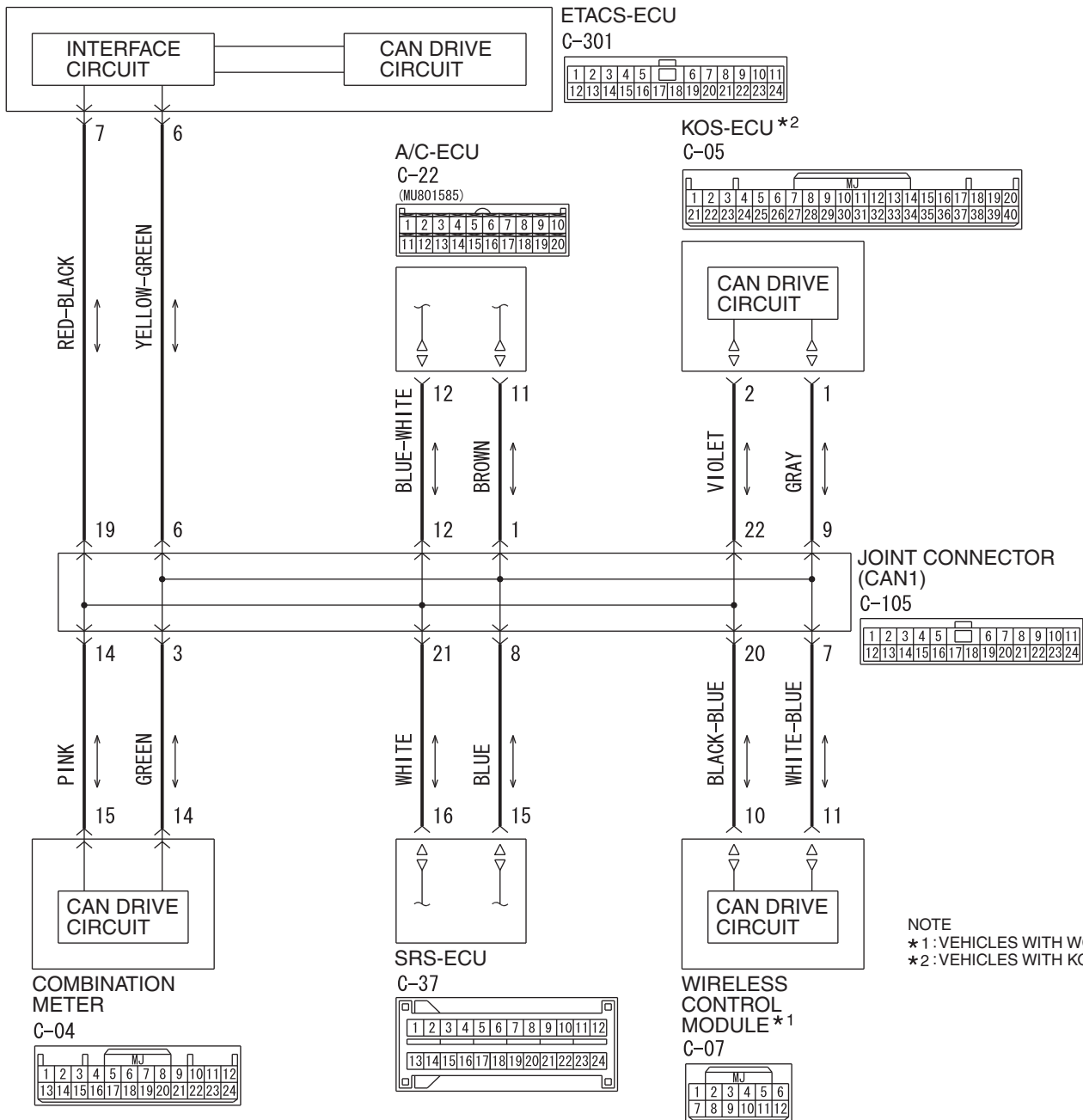

CAN-B Communication Circuit

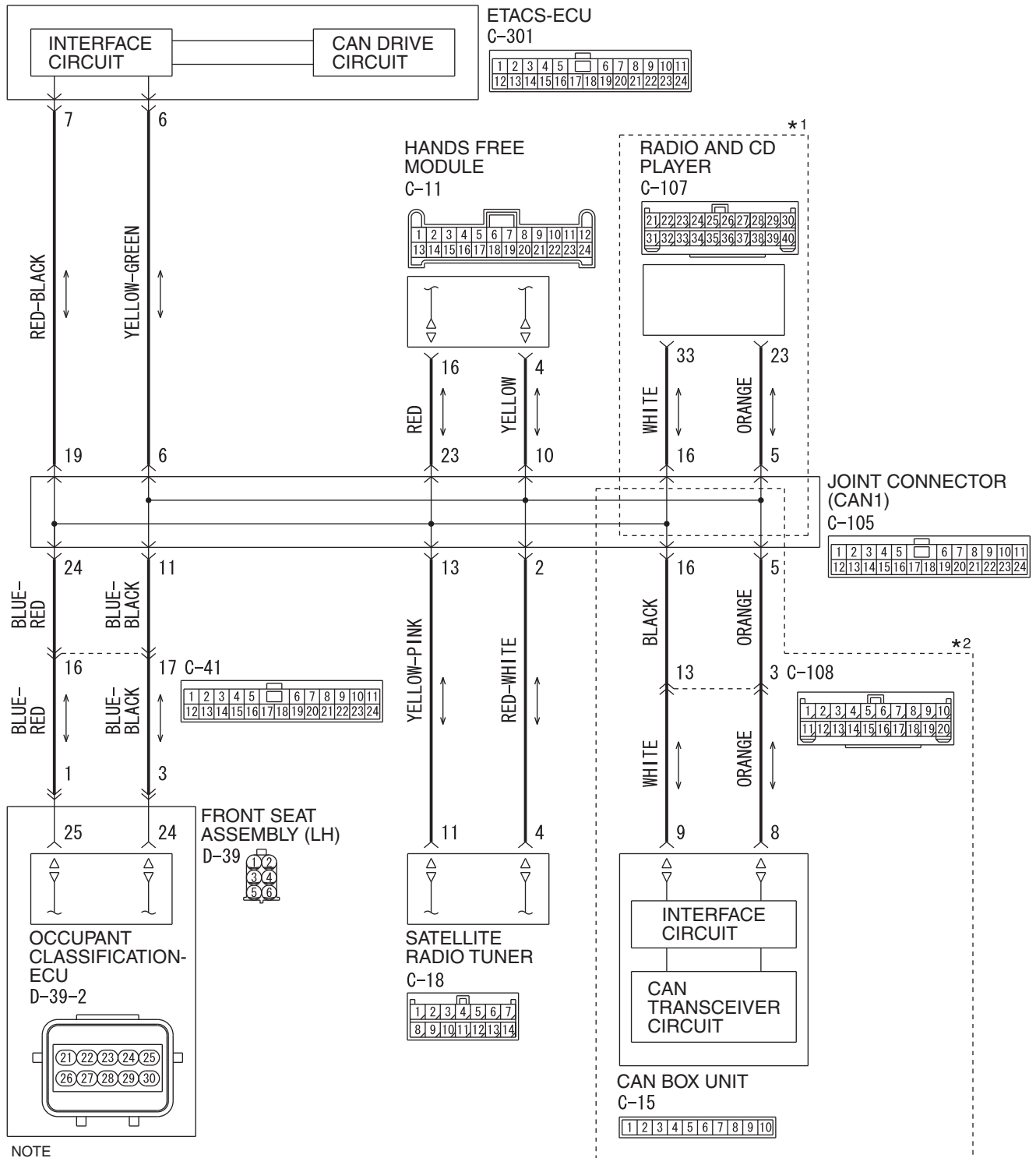

NOTE  
\*1: VEHICLES WITHOUT MITSUBISHI MULTI-COMMUNICATION SYSTEM (MMCS)  
\*2: VEHICLES WITH MITSUBISHI MULTI-COMMUNICATION SYSTEM (MMCS)

W9H54M093A

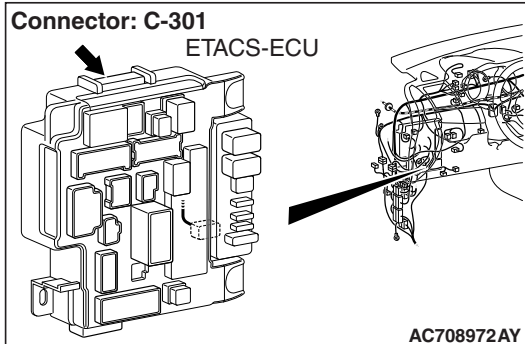
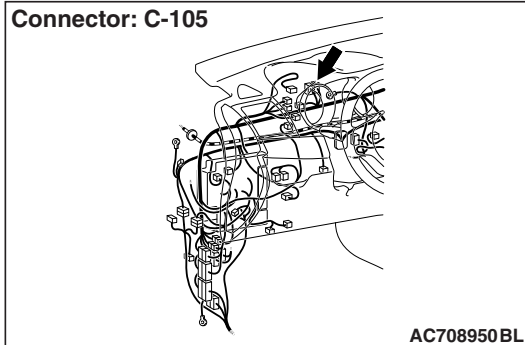

## FUNCTION

If a failure is present in the wiring harness wires between the ETACS-ECU connector, the joint connector (CAN1), the ETACS-ECU connector and the joint connector (CAN1), this diagnosis result will be set.

## TROUBLE JUDGMENT CONDITIONS

If a communication flag is set for none of the ECUs on the CAN-B line, the ETACS-ECU determines that there is a failure.

## TROUBLESHOOTING HINTS

- Malfunction of the connector [joint connector (CAN1) or ETACS-ECU connector improperly connected]
- Malfunction of the wiring harness [open circuit between the ETACS-ECU connector and the joint connector (CAN1)]
- Malfunction of the ETACS-ECU

## DIAGNOSIS

### Required Special Tools:

- MB991223: Harness Set
- MB992006: Extra Fine Probe

**STEP 1. Check joint connector (CAN1) C-105 and ETACS-ECU connector C-301 for loose, corroded or damaged terminals, or terminals pushed back in the connector.**

### **⚠ CAUTION**

The strand end of the twisted wire should be within 10 cm (4 inches) from the connector. For details refer to [P.54C-7](#).

**Q: Are joint connector (CAN1) C-105 and ETACS-ECU connector C-301 in good condition?**

**YES :** Go to Step 2.

**NO :** Repair the damaged parts.

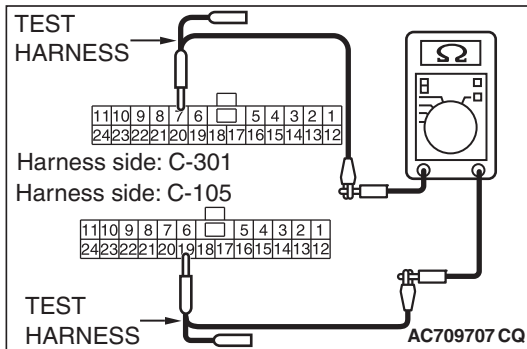
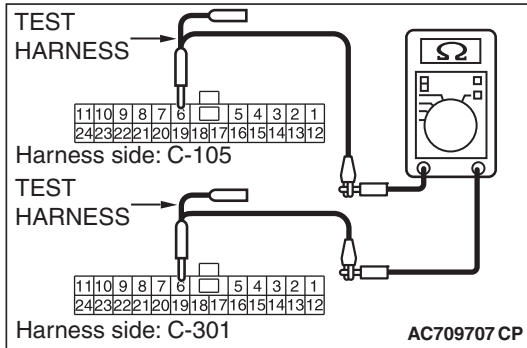

**STEP 2. Check the wiring harness between joint connector (CAN1) C-105 and ETACS-ECU connector C-301.**

**⚠ CAUTION**

**Strictly observe the specified wiring harness repair procedure. For details refer to P.54C-7.**

- (1) Disconnect joint connector (CAN1) C-105 and ETACS-ECU connector C-301, and check the wiring harness.
- (2) Check the wiring harness between joint connector (CAN1) C-105 (terminal 6) and ETACS-ECU connector C-301 (terminal 6)

**OK: Continuity exists (2 Ω or less)**

- (3) Check the wiring harness between joint connector (CAN1) C-105 (terminal 19) and ETACS-ECU connector C-301 (terminal 7)

**OK: Continuity exists (2 Ω or less)**

**Q: Is the wiring harness between joint connector (CAN1) C-105 and ETACS-ECU connector C-301 in good condition?**

**YES :** Go to Step 3.

**NO :** Repair the wiring harness between joint connector (CAN1) C-105 and ETACS-ECU connector C-301.

**STEP 3. Using scan tool MB991958, diagnose the CAN bus line. (trouble symptom check)**

**⚠ CAUTION**

Strictly observe the specified wiring harness repair procedure. For details refer to [P.54C-7](#).

**⚠ CAUTION**

To prevent damage to scan tool MB991958, always turn the ignition switch to the "LOCK" (OFF) position before connecting or disconnecting scan tool MB991958.

- (1) Connect scan tool MB991958 to the data link connector.
- (2) Turn the ignition switch to the "ON" position.

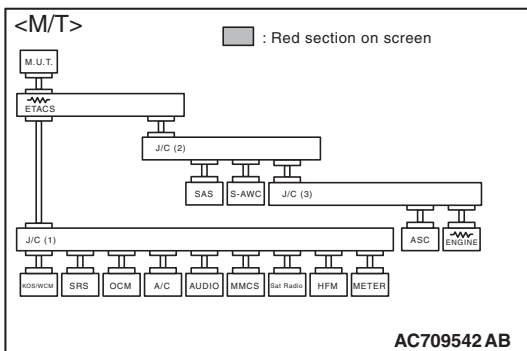
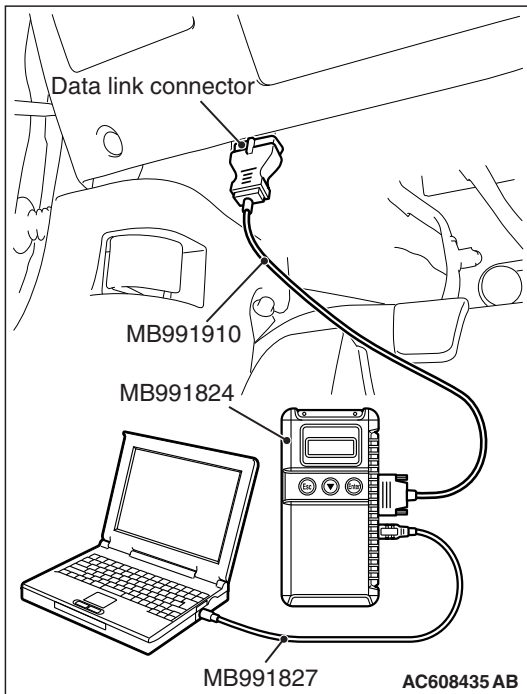

- (3) Diagnose CAN bus lines, and check if the scan tool MB991958 screen is as shown in the figure.

**OK:** The display of the scan tool MB991958 is as shown in the figure.

**Q:** Does scan tool MB991958 screen correspond to the illustration?

**YES :** The trouble can be an intermittent malfunction (Refer to GROUP 00, How to use Troubleshooting/inspection Service Points –How to Cope with Intermittent Malfunction [P.00-15](#)).

**NO :** Replace the ETACS-ECU.

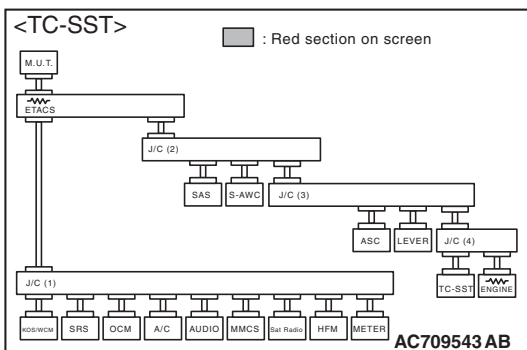

**DIAGNOSTIC ITEM 27: Short to power supply or ground, open circuit or line-to-line short in the CAN-B bus lines.**

**CAUTION**

When servicing a CAN bus line, ground yourself by touching a metal object such as an unpainted water pipe. If you fail to do so, a component connected to the CAN bus line may be damaged.

**CAN-B Communication Circuit**

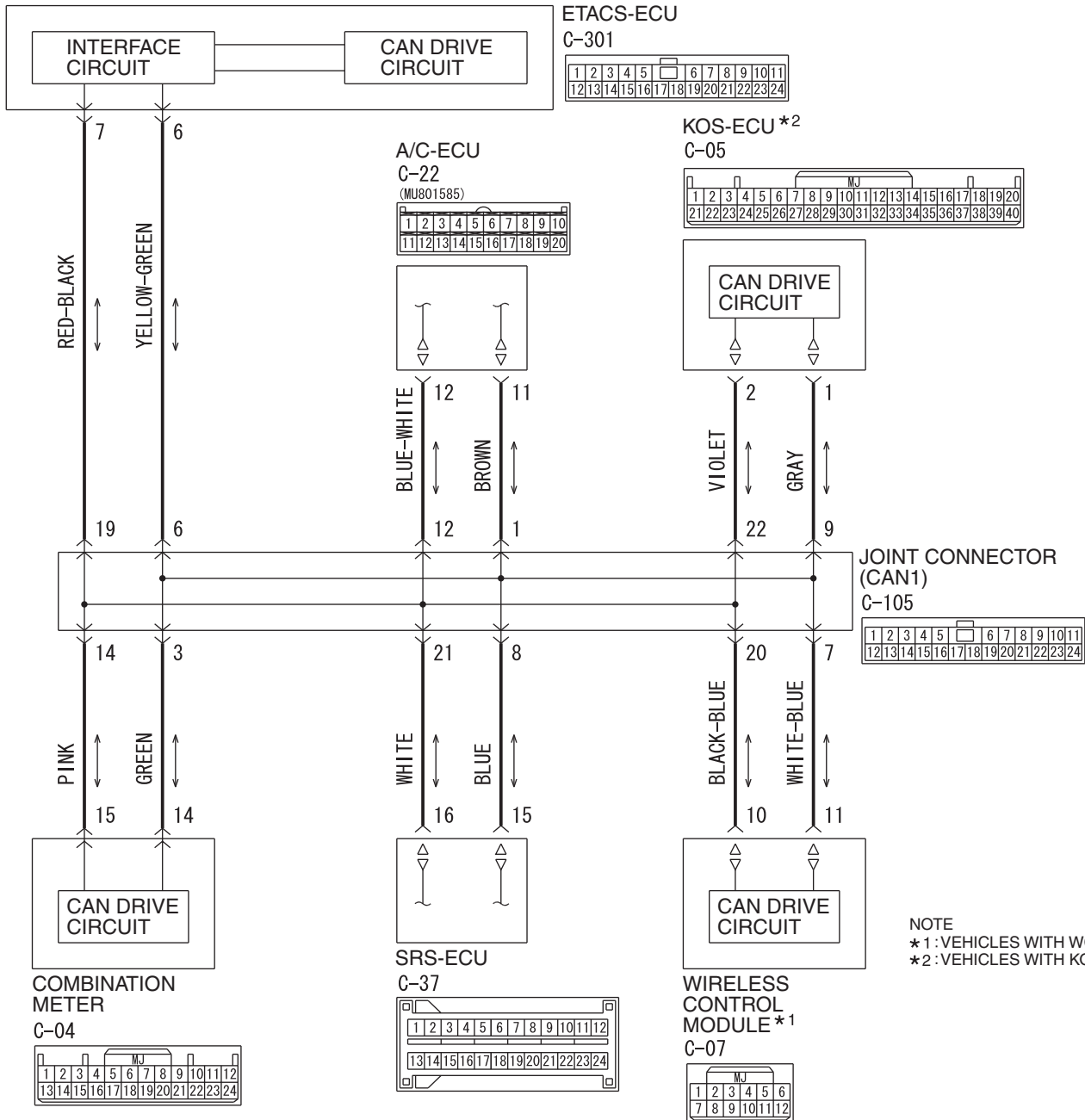

NOTE  
\*1 : VEHICLES WITH WCM  
\*2 : VEHICLES WITH KOS

CAN-B Communication Circuit

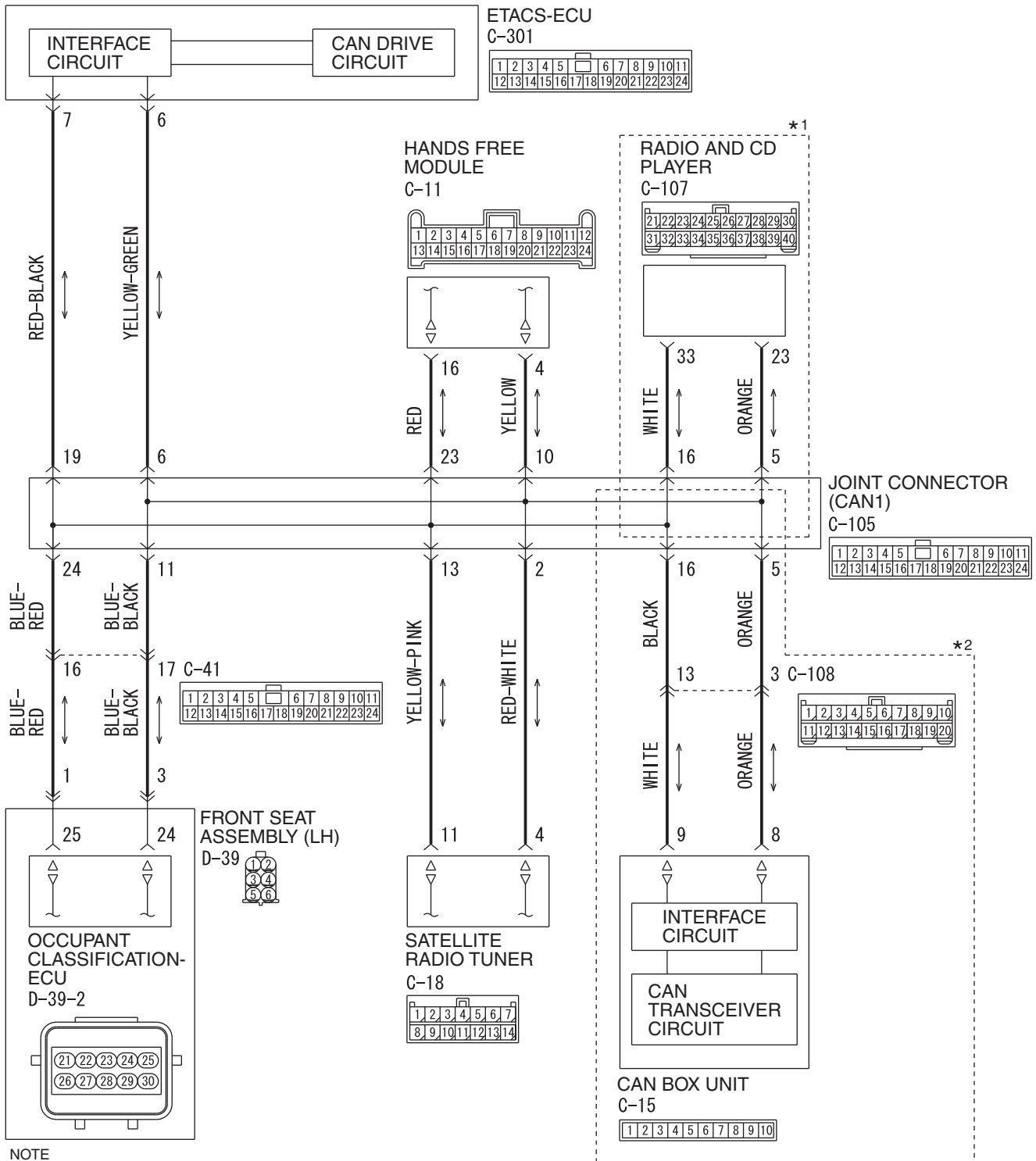

NOTE  
\*1: VEHICLES WITHOUT MITSUBISHI MULTI-COMMUNICATION SYSTEM (MMCS)  
\*2: VEHICLES WITH MITSUBISHI MULTI-COMMUNICATION SYSTEM (MMCS)

W9H54M093A

Connectors: C-04, C-06, C-09, C-31, C-122

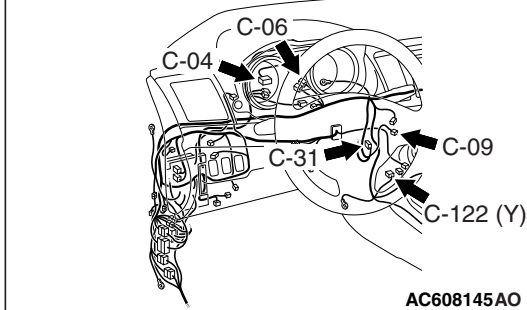

Connector: C-301

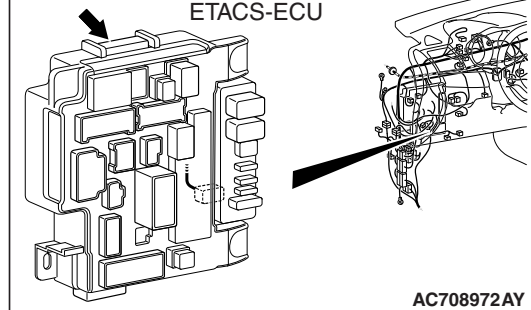

Connectors: C-17, C-20, C-104, C-108, C-110

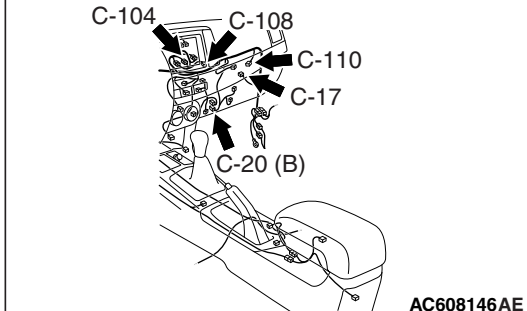

Connectors: D-39, D-39-2

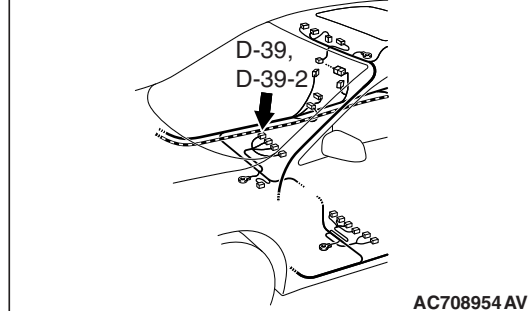

Connectors: C-05, C-41, C-105

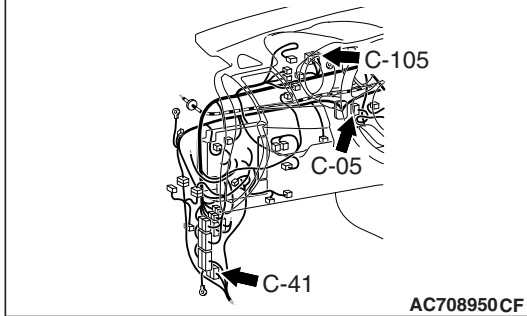
**FUNCTION**

If a short to power supply or ground, open circuit or line-to-line short is present at either CAN\_H or CAN\_L side on the CAN-B lines, this diagnosis result will be set.

**TROUBLE JUDGMENT CONDITIONS**

When CAN-B lines communication is normal, and diagnostic trouble code U0019 is set, the ETACS-ECU determines that there is a failure.

Connectors: C-07, C-11, C-15, C-18, C-22, C-37, C-107

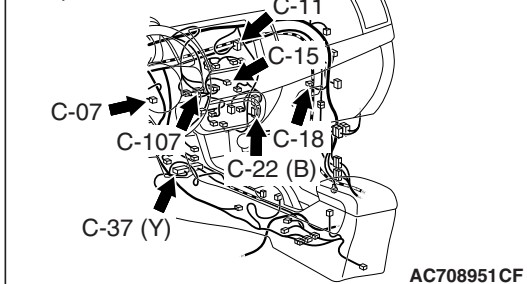
**TROUBLESHOOTING HINTS**

- Malfunction of the connector (short to power supply or ground in connector or improperly connected)
- Malfunction of the wiring harness (short to power supply or ground, open circuit or line-to-line short in CAN bus lines)
- Faulty ECU(s) (internal short to power supply or ground)



## DIAGNOSIS

### Required Special Tools:

- MB991223: Harness Set
- MB992006: Extra Fine Probe

**STEP 1. Check the wiring harness between ETACS-ECU connector C-301 and body ground for a short to ground. Measure the resistance at ETACS-ECU connector C-301.**

**⚠ CAUTION**

Disconnect the negative battery terminal. For details refer to [P.54C-7](#).

**⚠ CAUTION**

A digital multimeter should be used. For details refer to [P.54C-7](#).

**⚠ CAUTION**

The test wiring harness should be used. For details refer to [P.54C-7](#).

- (1) Disconnect ETACS-ECU connector C-301, and measure the voltage at the wiring harness side of ETACS-ECU connector.
- (2) Measure the resistance between ETACS-ECU connector terminal 6 and body ground.

**OK: 1 kΩ or more**

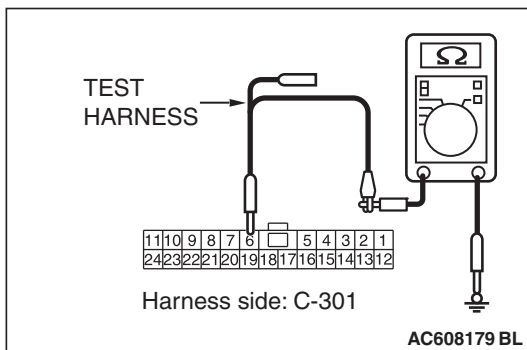

- (3) Measure the resistance between ETACS-ECU connector terminal 7 and body ground.

**OK: 1 kΩ or more**

**Q: Do all the resistances measure 1 kΩ or more?**

**YES :** Go to Step 2.

**NO :** Go to Step 13.

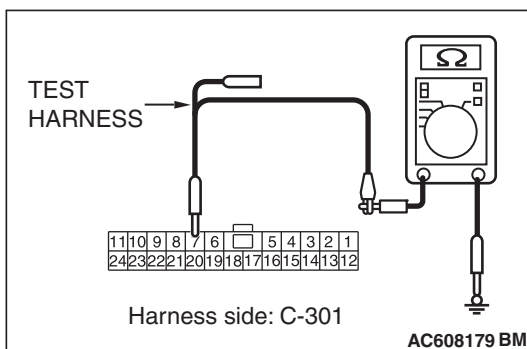

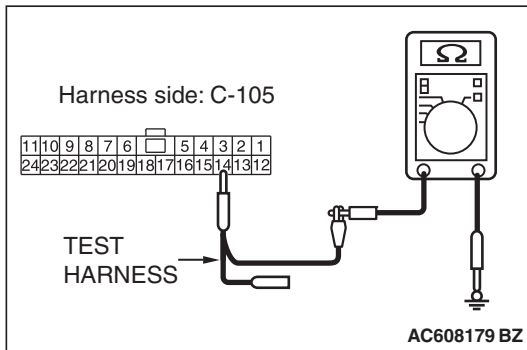
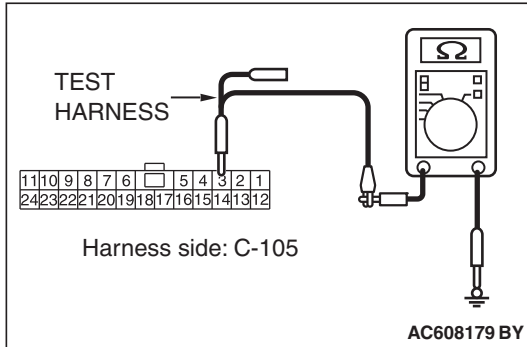

**STEP 2. Check the wiring harness between joint connector (CAN1) C-105 and combination meter connector C-04 for a short to ground. Measure the resistance at joint connector (CAN1) C-105.**

- (1) Disconnect joint connector (CAN1), and measure the resistance at the wiring harness side of joint connector (CAN1).
- (2) Measure the resistance between joint connector (CAN1) terminal 3 and body ground.

**OK: 1 k $\Omega$  or more**

- (3) Measure the resistance between joint connector (CAN1) terminal 14 and body ground.

**OK: 1 k $\Omega$  or more**

**Q: Do all the resistances measure 1 k $\Omega$  or more?**

**YES (vehicles with KOS) :** Go to Step 3.

**YES (vehicles with WCM) :** Go to Step 4.

**NO (vehicles with KOS or WCM) :** Go to Step 48.

**STEP 3. Check the wiring harness between joint connector (CAN1) C-105 and KOS-ECU connector C-05 for a short to ground. Measure the resistance at joint connector (CAN1) C-105.**

- (1) Disconnect joint connector (CAN1), and measure the resistance at the wiring harness side of joint connector (CAN1).
- (2) Measure the resistance between joint connector (CAN1) terminal 9 and body ground.

**OK: 1 k $\Omega$  or more**

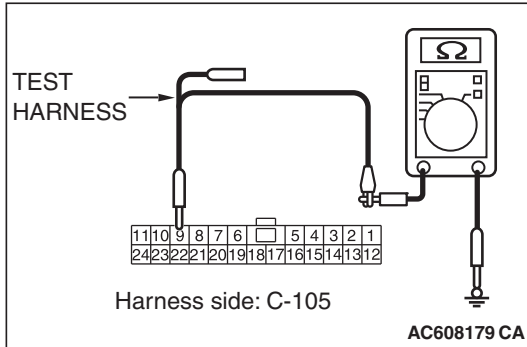

- (3) Measure the resistance between joint connector (CAN1) terminal 22 and body ground.

**OK: 1 k $\Omega$  or more**

**Q: Do all the resistances measure 1 k $\Omega$  or more?**

**YES :** Go to Step 5.

**NO :** Go to Step 49.

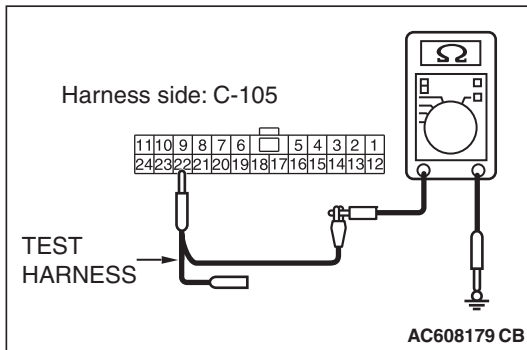

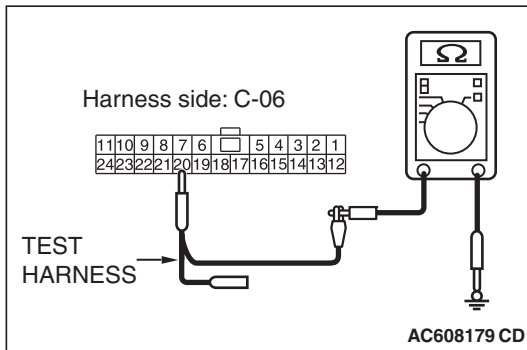
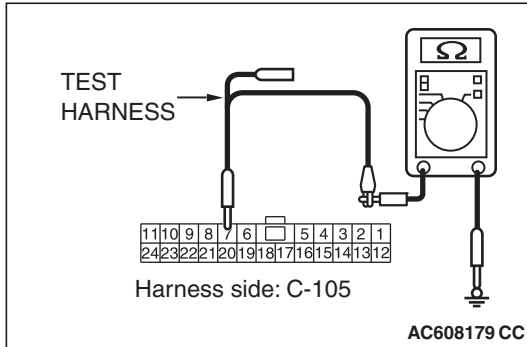

**STEP 4. Check the wiring harness between joint connector (CAN1) C-105 and WCM connector C-07 for a short to ground. Measure the resistance at joint connector (CAN1) C-105.**

- (1) Disconnect joint connector (CAN1), and measure the resistance at the wiring harness side of joint connector (CAN1).
- (2) Measure the resistance between joint connector (CAN1) terminal 7 and body ground.

**OK: 1 k $\Omega$  or more**

- (3) Measure the resistance between joint connector (CAN1) terminal 20 and body ground.

**OK: 1 k $\Omega$  or more**

**Q: Do all the resistances measure 1 k $\Omega$  or more?**

**YES :** Go to Step 5.

**NO :** Go to Step 50.

**STEP 5. Check the wiring harness between joint connector (CAN1) C-105 and SRS-ECU connector C-37 for a short to ground. Measure the resistance at joint connector (CAN1) C-105.**

- (1) Disconnect joint connector (CAN1), and measure the resistance at the wiring harness side of joint connector (CAN1).
- (2) Measure the resistance between joint connector (CAN1) terminal 8 and body ground.

**OK: 1 k $\Omega$  or more**

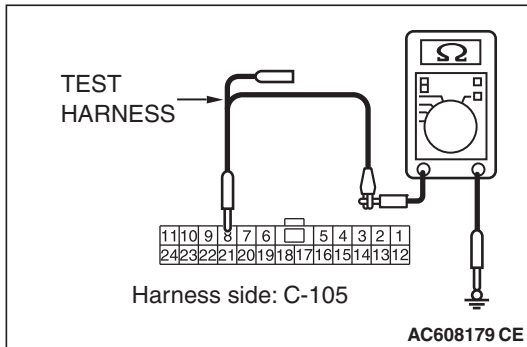

- (3) Measure the resistance between joint connector (CAN1) terminal 21 and body ground.

**OK: 1 k $\Omega$  or more**

**Q: Do all the resistances measure 1 k $\Omega$  or more?**

**YES :** Go to Step 6.

**NO :** Go to Step 51.

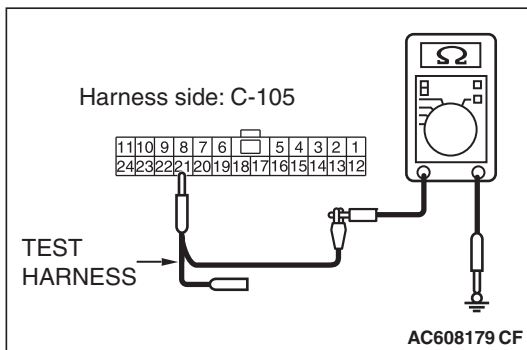

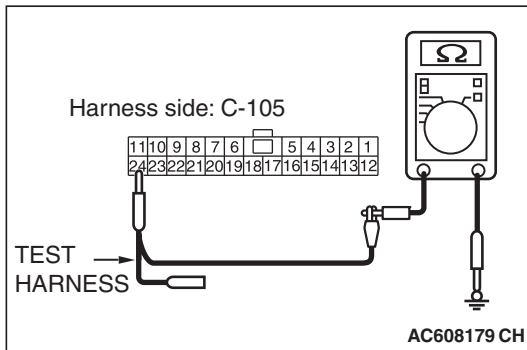
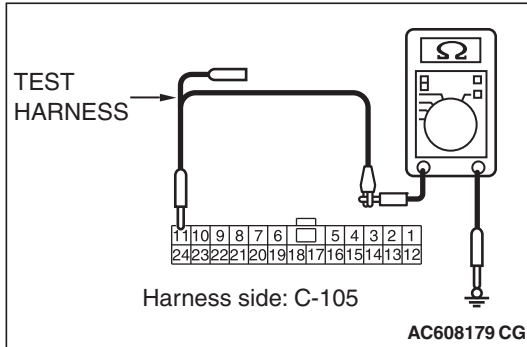

**STEP 6. Check the wiring harness between joint connector (CAN1) C-105 and occupant classification-ECU connector D-39-2 for a short to ground. Measure the resistance at joint connector (CAN1) C-105.**

- (1) Disconnect joint connector (CAN1), and measure the resistance at the wiring harness side of joint connector (CAN1).
- (2) Measure the resistance between joint connector (CAN1) terminal 11 and body ground.

**OK: 1 k $\Omega$  or more**

- (3) Measure the resistance between joint connector (CAN1) terminal 24 and body ground.

**OK: 1 k $\Omega$  or more**

**Q: Do all the resistances measure 1 k $\Omega$  or more?**

**YES (vehicles without hands free system) :** Go to Step 8.

**YES (vehicles with hands free system) :** Go to Step 7.

**NO :** Go to Step 52.

**STEP 7. Check the wiring harness between joint connector (CAN1) C-105 and hands free module connector C-11 for a short to ground. Measure the resistance at joint connector (CAN1) C-105.**

- (1) Disconnect joint connector (CAN1), and measure the resistance at the wiring harness side of joint connector (CAN1).
- (2) Measure the resistance between joint connector (CAN1) terminal 10 and body ground.

**OK: 1 k $\Omega$  or more**

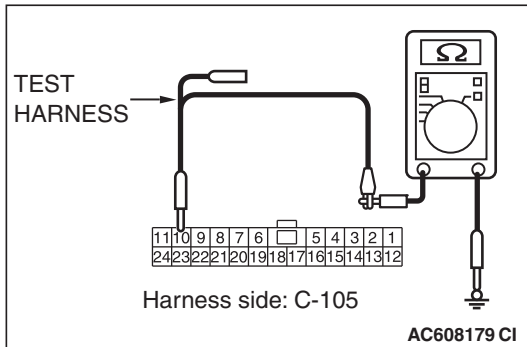

- (3) Measure the resistance between joint connector (CAN1) terminal 23 and body ground.

**OK: 1 k $\Omega$  or more**

**Q: Do all the resistances measure 1 k $\Omega$  or more?**

**YES :** Go to Step 8.

**NO :** Go to Step 53.

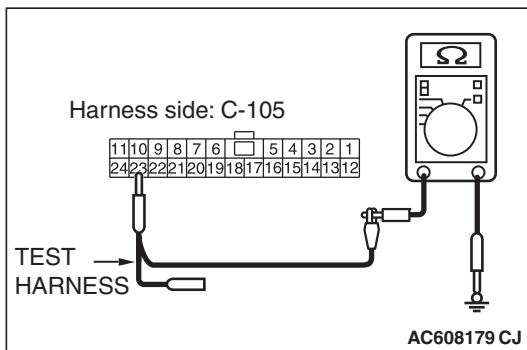

**STEP 8. Check the wiring harness between joint connector (CAN1) C-105 and A/C-ECU connector C-22 <vehicles with A/C> or heater control unit connector C-53 <vehicles without A/C> for a short to ground. Measure the resistance at joint connector (CAN1) C-105.**

- (1) Disconnect joint connector (CAN1), and measure the resistance at the wiring harness side of joint connector (CAN1).
- (2) Measure the resistance between joint connector (CAN1) terminal 1 and body ground.

**OK: 1 k $\Omega$  or more**

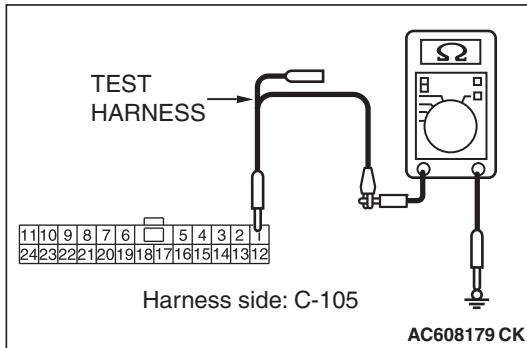

- (3) Measure the resistance between joint connector (CAN1) terminal 12 and body ground.

**OK: 1 k $\Omega$  or more**

**Q: Do all the resistances measure 1 k $\Omega$  or more?**

**YES (vehicles without MMCS) :** Go to Step 9.

**YES (vehicles with MMCS) :** Go to Step 10.

**NO :** Go to Step 54.

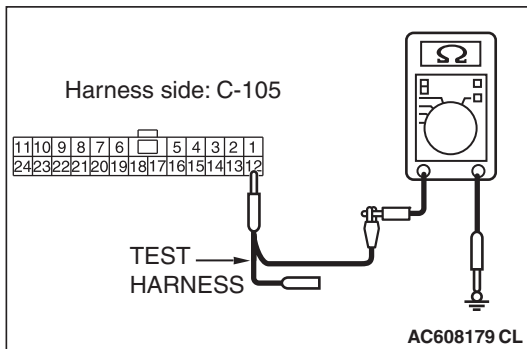



**STEP 9. Check the wiring harness between joint connector (CAN1) C-105 and radio and CD player or CD changer connector C-107 for a short to ground. Measure the resistance at joint connector (CAN1) C-105.**

- (1) Disconnect joint connector (CAN1), and measure the resistance at the wiring harness side of joint connector (CAN1).
- (2) Measure the resistance between joint connector (CAN1) terminal 5 and body ground.

**OK: 1 k $\Omega$  or more**

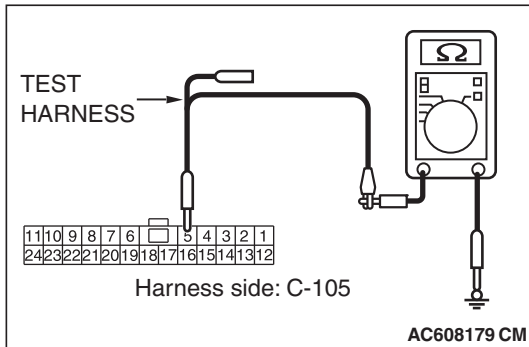

- (3) Measure the resistance between joint connector (CAN1) terminal 16 and body ground.

**OK: 1 k $\Omega$  or more**

**Q: Do all the resistances measure 1 k $\Omega$  or more?**

**YES (vehicles without satellite radio) :** Go to Step 12.

**YES (vehicles with satellite radio) :** Go to Step 11.

**NO :** Go to Step 55.

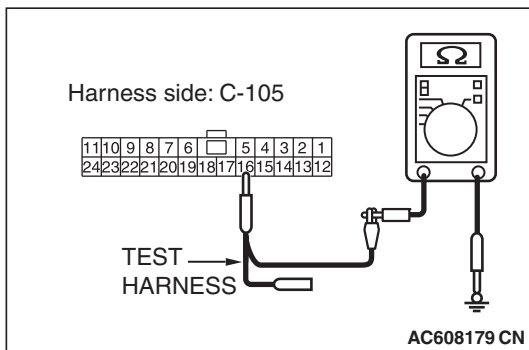

**STEP 10. Check the wiring harness between joint connector (CAN1) C-105 and CAN box unit connector C-15 for a short to ground. Measure the resistance at joint connector (CAN1) C-105.**

- (1) Disconnect joint connector (CAN1), and measure the resistance at the wiring harness side of joint connector (CAN1).
- (2) Measure the resistance between joint connector (CAN1) terminal 5 and body ground.

**OK: 1 k $\Omega$  or more**

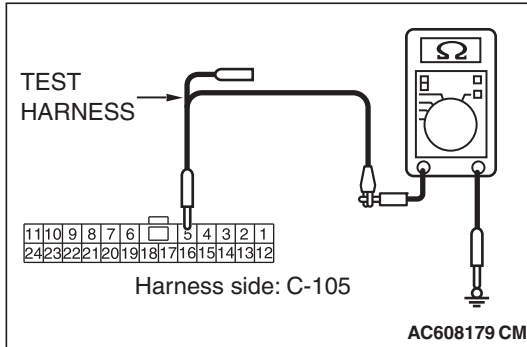

- (3) Measure the resistance between joint connector (CAN1) terminal 16 and body ground.

**OK: 1 k $\Omega$  or more**

**Q: Do all the resistances measure 1 k $\Omega$  or more?**

**YES (vehicles without satellite radio) :** Go to Step 12.

**YES (vehicles with satellite radio) :** Go to Step 11.

**NO :** Go to Step 56.

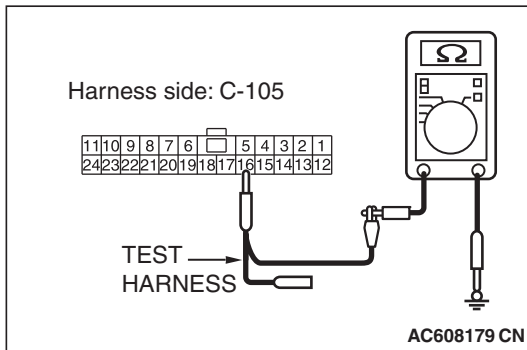

**STEP 11. Check the wiring harness between joint connector (CAN1) C-105 and satellite radio tuner connector C-18 for a short to ground. Measure the resistance at joint connector (CAN1) C-105.**

- (1) Disconnect joint connector (CAN1), and measure the resistance at the wiring harness side of joint connector (CAN1).
- (2) Measure the resistance between joint connector (CAN1) terminal 2 and body ground.

**OK: 1 k $\Omega$  or more**

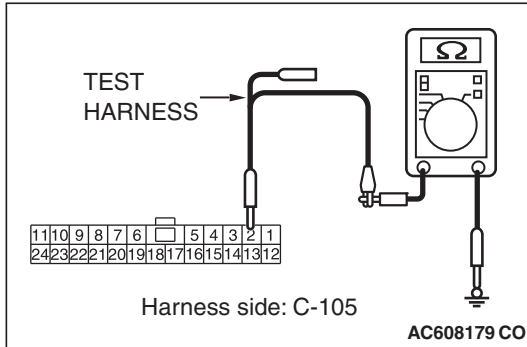

- (3) Measure the resistance between joint connector (CAN1) terminal 13 and body ground.

**OK: 1 k $\Omega$  or more**

**Q: Do all the resistances measure 1 k $\Omega$  or more?**

**YES :** Go to Step 12.

**NO :** Go to Step 57.

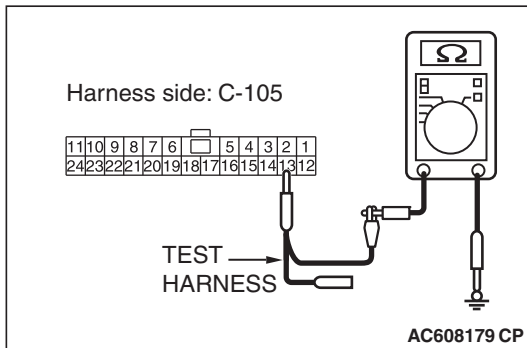

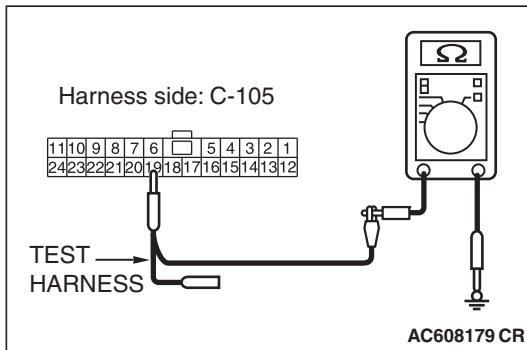
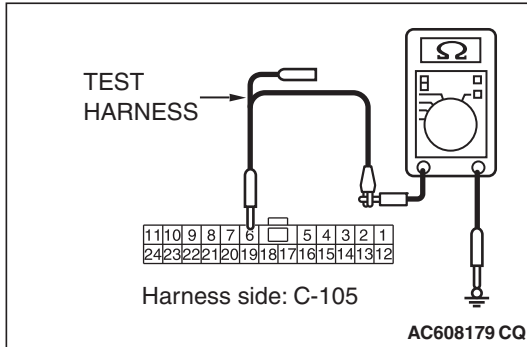

**STEP 12. Check the wiring harness between joint connector (CAN1) C-105 and ETACS-ECU connector C-301 for a short to ground. Measure the resistance at joint connector (CAN1) C-105.**

- (1) Disconnect joint connector (CAN1) and ETACS-ECU connector C-301, and measure the resistance at the wiring harness side of joint connector (CAN1).
- (2) Measure the resistance between joint connector (CAN1) terminal 6 and body ground.

**OK: 1 k $\Omega$  or more**

- (3) Measure the resistance between joint connector (CAN1) terminal 19 and body ground.

**OK: 1 k $\Omega$  or more**

**Q: Do all the resistances measure 1 k $\Omega$  or more?**

**YES :** Go to Step 58.

**NO :** Repair the wiring harness between joint connector (CAN1) C-105 and ETACS-ECU connector C-301.

**STEP 13. Check the wiring harness between ETACS-ECU connector C-301 and body ground for a short to power supply. Measure the voltage at ETACS-ECU connector C-301.**

- (1) Disconnect ETACS-ECU connector C-301, and measure the voltage at the wiring harness side of ETACS-ECU connector.
- (2) Turn the ignition switch to the ON position.
- (3) Measure the voltage between ETACS-ECU connector terminal 6 and body ground.

**OK: 4.7 V or less**

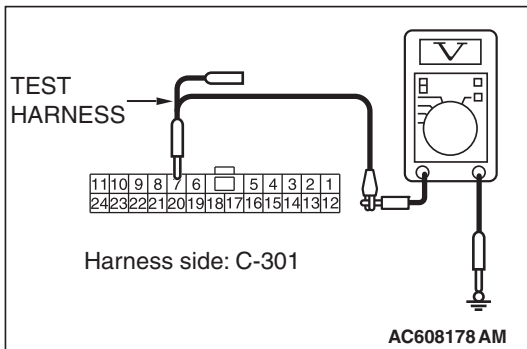
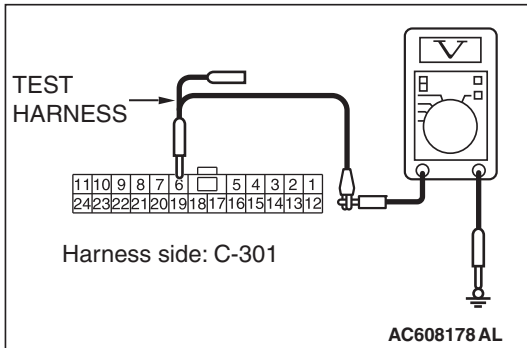

- (4) Measure the voltage between ETACS-ECU connector terminal 7 and body ground.

**OK: 4.7 V or less**

**Q: Do all the voltages measure 4.7 V or less?**

**YES :** Go to Step 25.

**NO :** Go to Step 14.

**STEP 14. Check the wiring harness between joint connector (CAN1) C-105 and combination meter connector C-04 for a short to power supply. Measure the voltage at joint connector (CAN1) C-105.**

- (1) Disconnect joint connector (CAN1), and measure the voltage at the wiring harness side of joint connector (CAN1).
- (2) Connect the negative battery terminal.
- (3) Turn the ignition switch to the ON position.
- (4) Measure the voltage between joint connector (CAN1) terminal 3 and body ground.

**OK: 4.7 V or less**

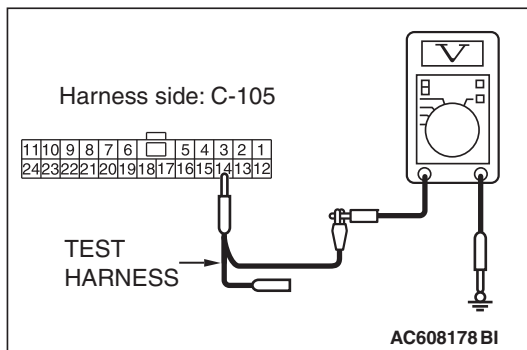
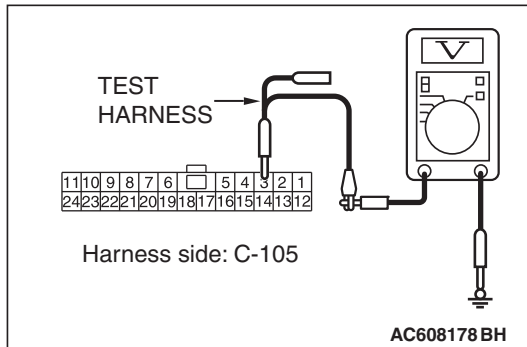

- (5) Measure the voltage between joint connector (CAN1) terminal 14 and body ground.

**OK: 4.7 V or less**

**Q: Do all the voltages measure 4.7 V or less?**

**YES (vehicles with KOS) :** Go to Step 15.

**YES (vehicles with WCM) :** Go to Step 16.

**NO (vehicles with KOS and WCM) :** Go to Step 48.

**STEP 15. Check the wiring harness between joint connector (CAN1) C-105 and KOS-ECU connector C-05 for a short to power supply. Measure the voltage at joint connector (CAN1) C-105.**

- (1) Disconnect joint connector (CAN1), and measure the voltage at the wiring harness side of joint connector (CAN1).
- (2) Turn the ignition switch to the ON position.
- (3) Measure the voltage between joint connector (CAN1) terminal 9 and body ground.

**OK: 4.7 V or less**

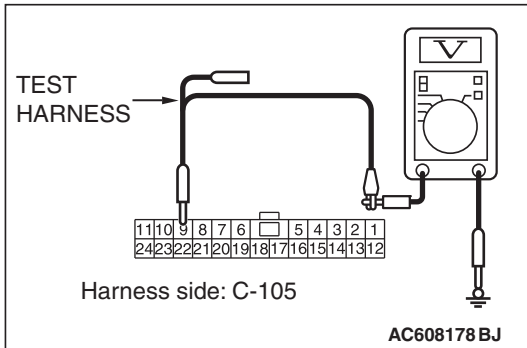

- (4) Measure the voltage between joint connector (CAN1) terminal 22 and body ground.

**OK: 4.7 V or less**

**Q: Do all the voltages measure 4.7 V or less?**

**YES :** Go to Step 17.

**NO :** Go to Step 49.

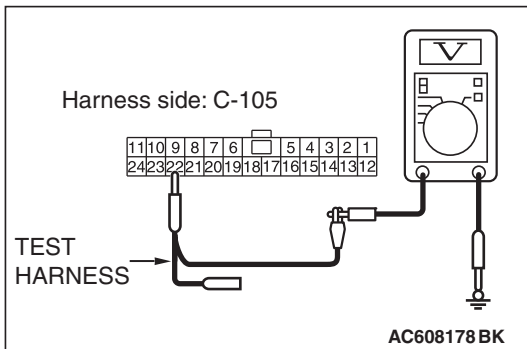

**STEP 16. Check the wiring harness between joint connector (CAN1) C-105 and WCM connector C-07 for a short to power supply. Measure the voltage at joint connector (CAN1) C-105.**

- (1) Disconnect joint connector (CAN1), and measure the voltage at the wiring harness side of joint connector (CAN1).
- (2) Turn the ignition switch to the ON position.
- (3) Measure the voltage between joint connector (CAN1) terminal 7 and body ground.

**OK: 4.7 V or less**

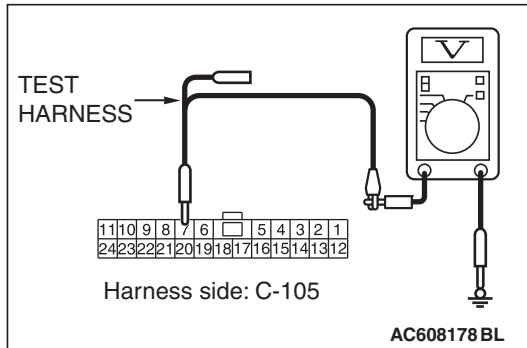

- (4) Measure the voltage between joint connector (CAN1) terminal 20 and body ground.

**OK: 4.7 V or less**

**Q: Do all the voltages measure 4.7 V or less?**

**YES :** Go to Step 17.

**NO :** Go to Step 50.

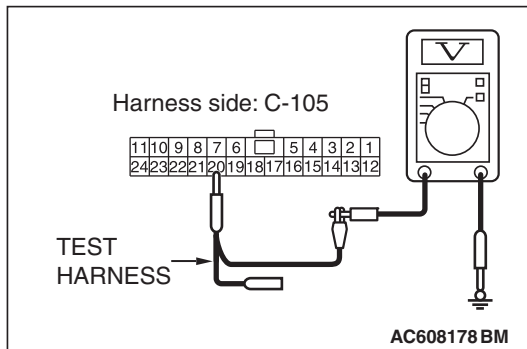



**STEP 17. Check the wiring harness between joint connector (CAN1) C-105 and SRS-ECU connector C-37 for a short to power supply. Measure the voltage at joint connector (CAN1) C-105.**

- (1) Disconnect joint connector (CAN1), and measure the voltage at the wiring harness side of joint connector (CAN1).
- (2) Turn the ignition switch to the ON position.
- (3) Measure the voltage between joint connector (CAN1) terminal 8 and body ground.

**OK: 4.7 V or less**

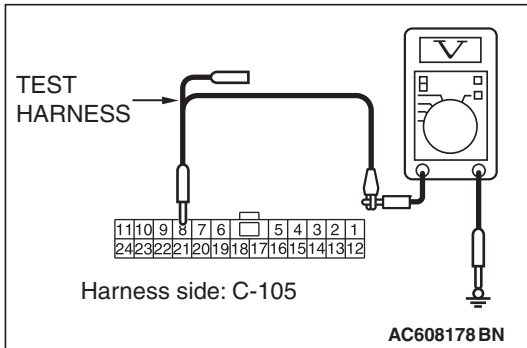

- (4) Measure the voltage between joint connector (CAN1) terminal 21 and body ground.

**OK: 4.7 V or less**

**Q: Do all the voltages measure 4.7 V or less?**

**YES :** Go to Step 18.

**NO :** Go to Step 51.

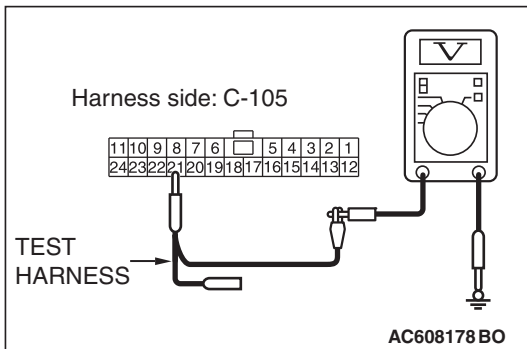

**STEP 18. Check the wiring harness between joint connector (CAN1) C-105 and occupant classification-ECU connector D-39-2 for a short to power supply. Measure the voltage at joint connector (CAN1) C-105.**

- (1) Disconnect joint connector (CAN1), and measure the voltage at the wiring harness side of joint connector (CAN1).
- (2) Turn the ignition switch to the ON position.
- (3) Measure the voltage between joint connector (CAN1) terminal 11 and body ground.

**OK: 4.7 V or less**

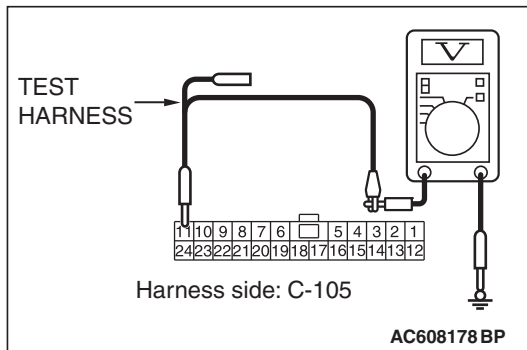

- (4) Measure the voltage between joint connector (CAN1) terminal 24 and body ground.

**OK: 4.7 V or less**

**Q: Do all the voltages measure 4.7 V or less?**

**YES (vehicles without hands free system) :** Go to Step 20.

**YES (vehicles with hands free system) :** Go to Step 19.

**NO :** Go to Step 52.

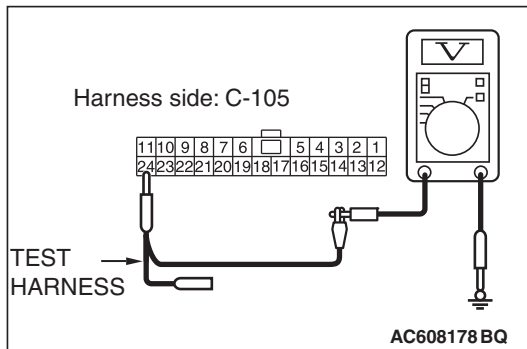

**STEP 19. Check the wiring harness between joint connector (CAN1) C-105 and hands free module connector C-11 for a short to power supply. Measure the voltage at joint connector (CAN1) C-105.**

- (1) Disconnect joint connector (CAN1), and measure the voltage at the wiring harness side of joint connector (CAN1).
- (2) Turn the ignition switch to the ON position.
- (3) Measure the voltage between joint connector (CAN1) terminal 10 and body ground.

**OK: 4.7 V or less**

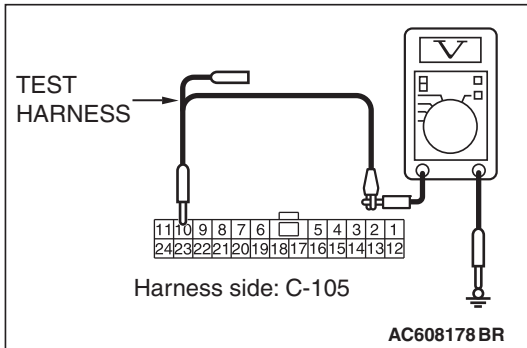

- (4) Measure the voltage between joint connector (CAN1) terminal 23 and body ground.

**OK: 4.7 V or less**

**Q: Do all the voltages measure 4.7 V or less?**

**YES :** Go to Step 20.

**NO :** Go to Step 53.

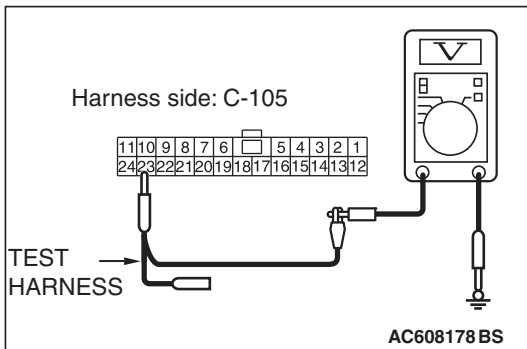

**STEP 20. Check the wiring harness between joint connector (CAN1) C-105 and A/C-ECU connector C-22 <vehicles with A/C> or heater control unit connector C-53 <vehicles without A/C> for a short to power supply.**

**Measure the voltage at joint connector (CAN1) C-105.**

- (1) Disconnect joint connector (CAN1), and measure the voltage at the wiring harness side of joint connector (CAN1).
- (2) Turn the ignition switch to the ON position.
- (3) Measure the voltage between joint connector (CAN1) terminal 1 and body ground.

**OK: 4.7 V or less**

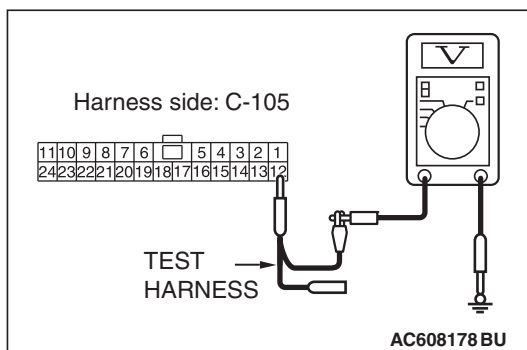
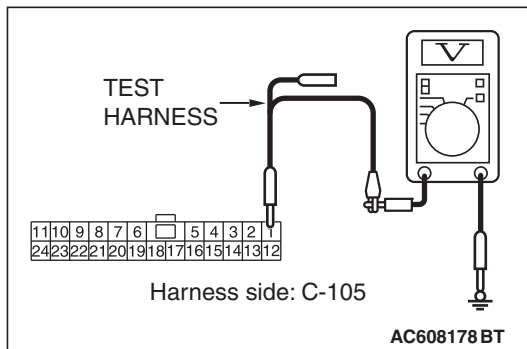

- (4) Measure the voltage between joint connector (CAN1) terminal 12 and body ground.

**OK: 4.7 V or less**

**Q: Do all the voltages measure 4.7 V or less?**

**YES (vehicles without MMCS) :** Go to Step 21.

**YES (vehicles with MMCS) :** Go to Step 22.

**NO :** Go to Step 54.

**STEP 21. Check the wiring harness between joint connector (CAN1) C-105 and radio and CD player or CD changer connector C-107 for a short to power supply. Measure the voltage at joint connector (CAN1) C-105.**

- (1) Disconnect joint connector (CAN1), and measure the voltage at the wiring harness side of joint connector (CAN1).
- (2) Turn the ignition switch to the ON position.
- (3) Measure the voltage between joint connector (CAN1) terminal 5 and body ground.

**OK: 4.7 V or less**

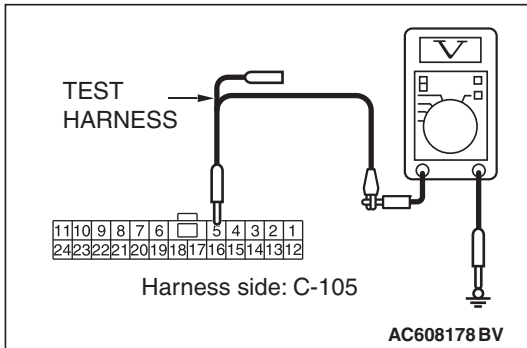

- (4) Measure the voltage between joint connector (CAN1) terminal 16 and body ground.

**OK: 4.7 V or less**

**Q: Do all the voltages measure 4.7 V or less?**

**YES (vehicles without satellite radio) :** Go to Step 24.

**YES (vehicles with satellite radio) :** Go to Step 23.

**NO :** Go to Step 55.

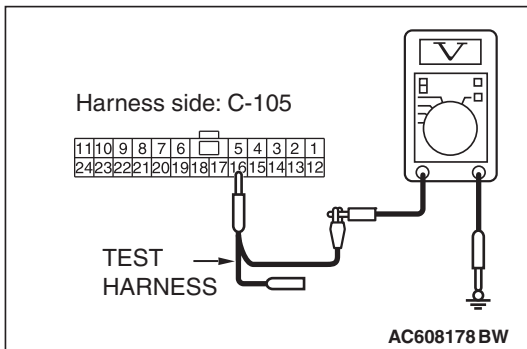

**STEP 22. Check the wiring harness between joint connector (CAN1) C-105 and CAN box unit connector C-15 for a short to power supply. Measure the voltage at joint connector (CAN1) C-105.**

- (1) Disconnect joint connector (CAN1), and measure the voltage at the wiring harness side of joint connector (CAN1).
- (2) Turn the ignition switch to the ON position.
- (3) Measure the voltage between joint connector (CAN1) terminal 5 and body ground.

**OK: 4.7 V or less**

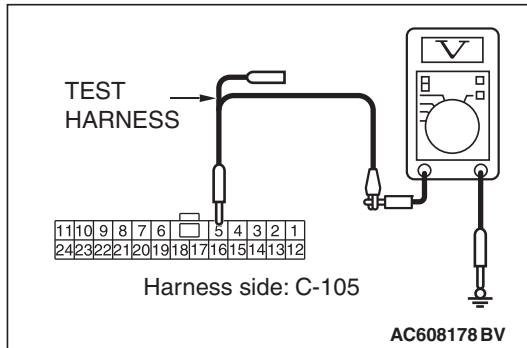

- (4) Measure the voltage between joint connector (CAN1) terminal 16 and body ground.

**OK: 4.7 V or less**

**Q: Do all the voltages measure 4.7 V or less?**

**YES (vehicles without satellite radio) :** Go to Step 24.

**YES (vehicles with satellite radio) :** Go to Step 23.

**NO :** Go to Step 56.

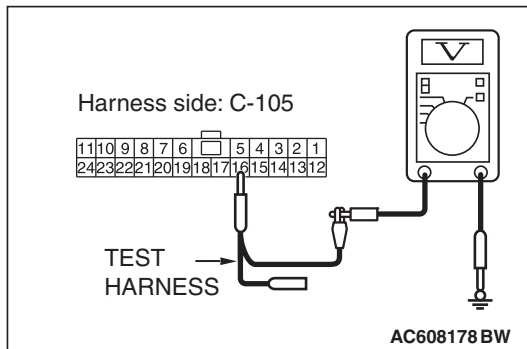

**STEP 23. Check the wiring harness between joint connector (CAN1) C-105 and satellite radio tuner connector C-18 for a short to power supply. Measure the voltage at joint connector (CAN1) C-105.**

- (1) Disconnect joint connector (CAN1), and measure the voltage at the wiring harness side of joint connector (CAN1).
- (2) Turn the ignition switch to the ON position.
- (3) Measure the voltage between joint connector (CAN1) terminal 2 and body ground.

**OK: 4.7 V or less**

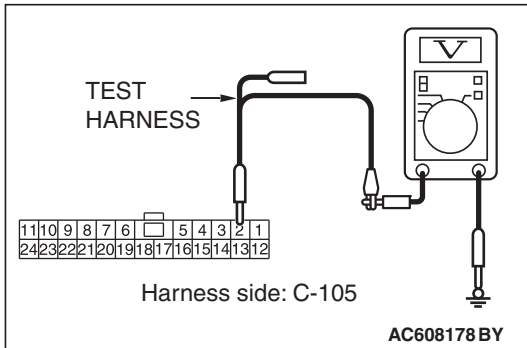

- (4) Measure the voltage between joint connector (CAN1) terminal 13 and body ground.

**OK: 4.7 V or less**

**Q: Do all the voltages measure 4.7 V or less?**

**YES :** Go to Step 24.

**NO :** Go to Step 57.

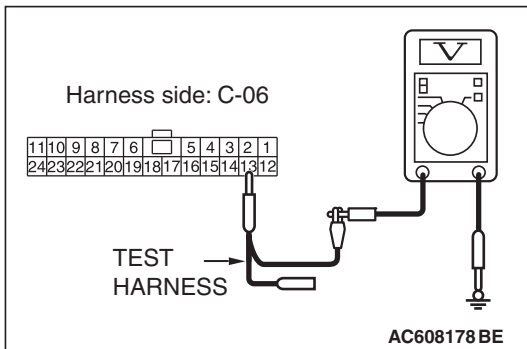

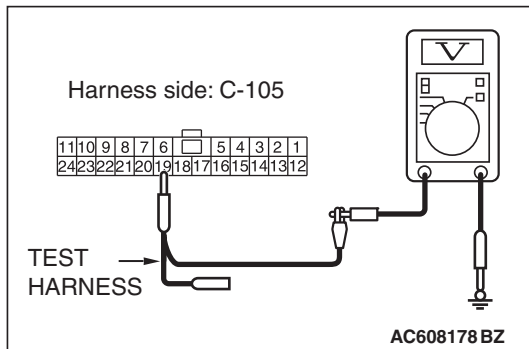
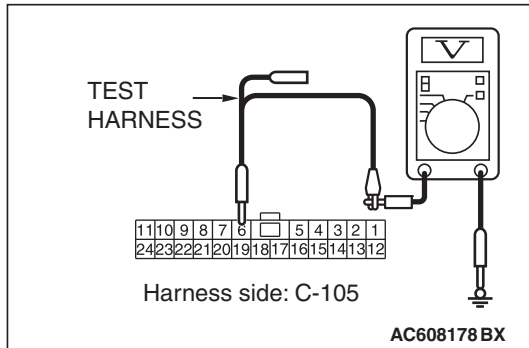

**STEP 24. Check the wiring harness between joint connector (CAN1) C-105 and ETACS-ECU connector C-301 for a short to power supply. Measure the voltage at joint connector (CAN1) C-105.**

- (1) Disconnect joint connector (CAN1) and ETACS-ECU connector C-301, and measure the voltage at the wiring harness side of joint connector (CAN1).
- (2) Turn the ignition switch to the ON position.
- (3) Measure the voltage between joint connector (CAN1) terminal 6 and body ground.

**OK: 1 V or less**

- (4) Measure the voltage between joint connector (CAN1) terminal 19 and body ground.

**OK: 1 V or less**

**Q: Do all the voltages measure 1 V or less?**

**YES :** Go to Step 58.

**NO :** Repair the wiring harness between joint connector (CAN1) C-105 and ETACS-ECU connector C-301.

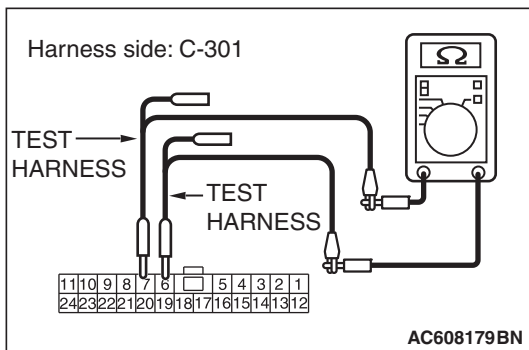

**STEP 25. Check the wiring harness for line-to-line short. Measure the resistance at ETACS-ECU connector C-301**

**⚠ CAUTION**

**Disconnect the negative battery terminal. For details refer to P.54C-7.**

- (1) Disconnect ETACS-ECU connector C-301, and check that there is continuity at the harness side of ETACS-ECU.
- (2) Check that there is continuity between ETACS-ECU connector terminals 6 and 7.

**OK: No continuity**

**Q: Is the check result normal?**

**YES :** Go to Step 37.

**NO :** Go to Step 26.



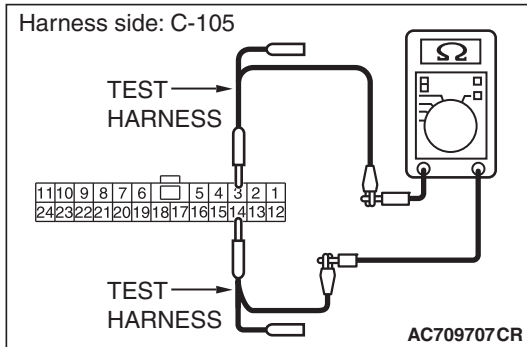

**STEP 26. Check the wiring harness between joint connector (CAN1) C-105 and combination meter connector C-04 for line-to-line short. Measure the resistance at joint connector (CAN1) C-105.**

- (1) Disconnect joint connector (CAN1), and check that there is continuity at the harness side of joint connector (CAN1).
- (2) Check that there is continuity between joint connector (CAN1) terminals 3 and 14.

**OK: No continuity**

**Q: Is the check result normal?**

**YES (vehicles with KOS) :** Go to Step 27.

**YES (vehicles with WCM) :** Go to Step 28.

**NO (vehicles with KOS or WCM) :** Go to Step 48.

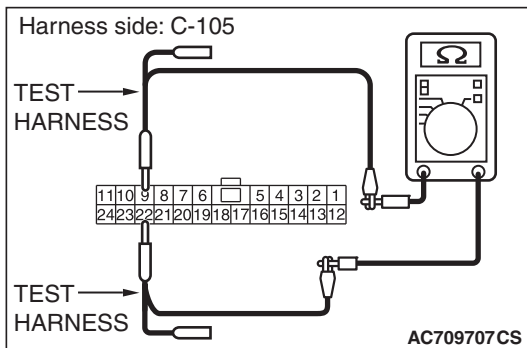

**STEP 27. Check the wiring harness between joint connector (CAN1) C-105 and KOS-ECU connector C-05 for line-to-line short. Measure the resistance at joint connector (CAN1) C-105.**

- (1) Disconnect joint connector (CAN1), and check that there is continuity at the harness side of joint connector (CAN1).
- (2) Check that there is continuity between joint connector (CAN1) terminals 9 and 22.

**OK: No continuity**

**Q: Is the check result normal?**

**YES :** Go to Step 29.

**NO :** Go to Step 49.

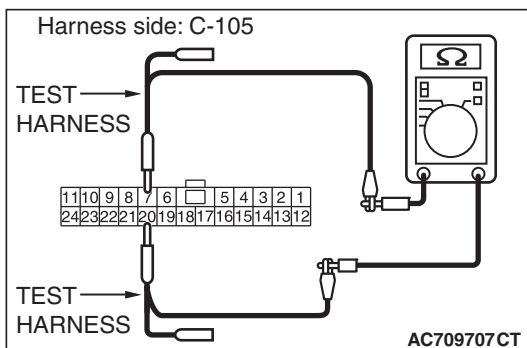

**STEP 28. Check the wiring harness between joint connector (CAN1) C-105 and WCM connector C-07 for line-to-line short. Measure the resistance at joint connector (CAN1) C-105.**

- (1) Disconnect joint connector (CAN1), and check that there is continuity at the harness side of joint connector (CAN1).
- (2) Check that there is continuity between joint connector (CAN1) terminals 7 and 20.

**OK: No continuity**

**Q: Is the check result normal?**

**YES :** Go to Step 29.

**NO :** Go to Step 50.

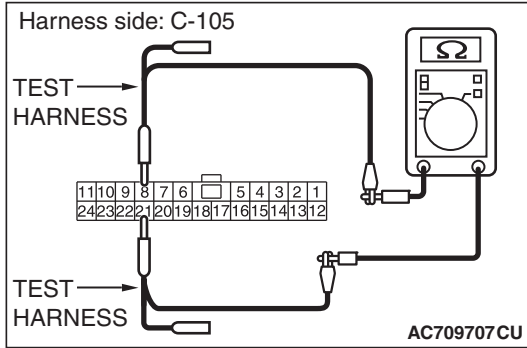

**STEP 29. Check the wiring harness between joint connector (CAN1) C-105 and SRS-ECU connector C-37 for line-to-line short. Measure the resistance at joint connector (CAN1) C-105.**

- (1) Disconnect joint connector (CAN1), and check that there is continuity at the harness side of joint connector (CAN1).
- (2) Check that there is continuity between joint connector (CAN1) terminals 8 and 21.

**OK: No continuity**

**Q: Is the check result normal?**

**YES :** Go to Step 30.

**NO :** Go to Step 51.

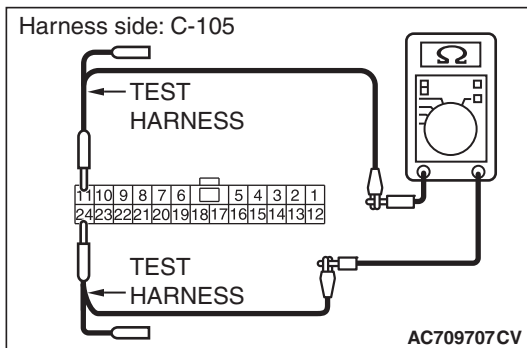

**STEP 30. Check the wiring harness between joint connector (CAN1) C-105 and occupant classification-ECU connector D-39-2 for line-to-line short. Measure the resistance at joint connector (CAN1) C-105.**

- (1) Disconnect joint connector (CAN1), and check that there is continuity at the harness side of joint connector (CAN1).
- (2) Check that there is continuity between joint connector (CAN1) terminals 11 and 24.

**OK: No continuity**

**Q: Is the check result normal?**

**YES (vehicles without hands free system) :** Go to Step 32.

**YES (vehicles with hands free system) :** Go to Step 31.

**NO :** Go to Step 52.

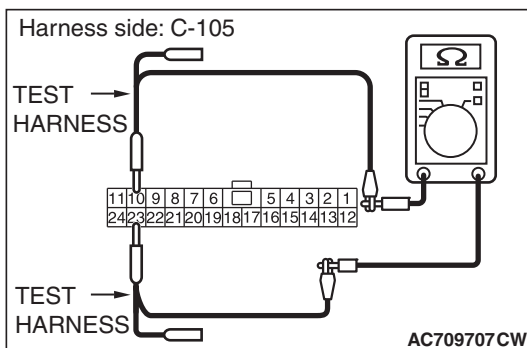

**STEP 31. Check the wiring harness between joint connector (CAN1) C-105 and hands free module connector C-11 for line-to-line short. Measure the resistance at joint connector (CAN1) C-105.**

- (1) Disconnect joint connector (CAN1), and check that there is continuity at the harness side of joint connector (CAN1).
- (2) Check that there is continuity between joint connector (CAN1) terminals 10 and 23.

**OK: No continuity**

**Q: Is the check result normal?**

**YES :** Go to Step 32.

**NO :** Go to Step 53.

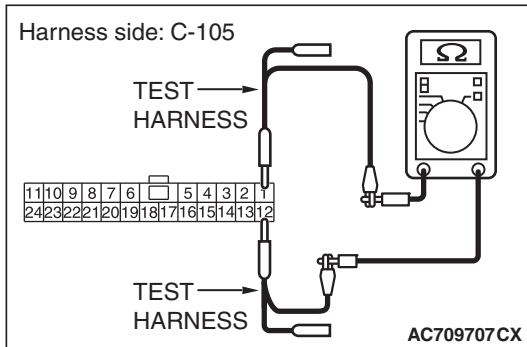

**STEP 32. Check the wiring harness between joint connector (CAN1) C-105 and A/C-ECU connector C-22 <vehicles with A/C> or heater control unit connector C-53 <vehicles without A/C> for line-to-line short. Measure the resistance at joint connector (CAN1) C-105.**

- (1) Disconnect joint connector (CAN1), and check that there is continuity at the harness side of joint connector (CAN1).
- (2) Check that there is continuity between joint connector (CAN1) terminals 1 and 12.

**OK: No continuity**

**Q: Is the check result normal?**

**YES (vehicles without MMCS) :** Go to Step 33.

**YES (vehicles with MMCS) :** Go to Step 34.

**NO :** Go to Step 54.

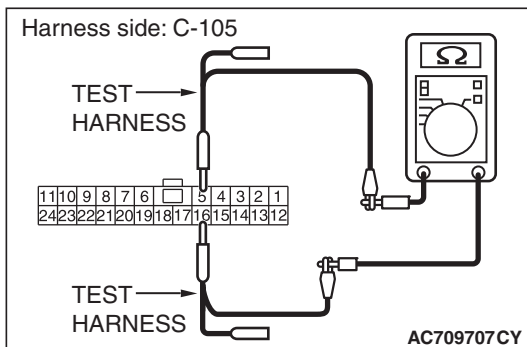

**STEP 33. Check the wiring harness between joint connector (CAN1) C-105 and radio and CD player or CD changer connector C-107 for line-to-line short. Measure the resistance at joint connector (CAN1) C-105.**

- (1) Disconnect joint connector (CAN1), and check that there is continuity at the harness side of joint connector (CAN1).
- (2) Check that there is continuity between joint connector (CAN1) terminals 5 and 16.

**OK: No continuity**

**Q: Is the check result normal?**

**YES (vehicles without satellite radio) :** Go to Step 36.

**YES (vehicles with satellite radio) :** Go to Step 35.

**NO :** Go to Step 55.

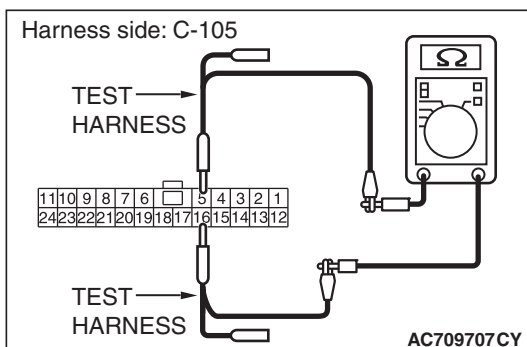

**STEP 34. Check the wiring harness between joint connector (CAN1) C-105 and CAN box unit connector C-15 for line-to-line short. Measure the resistance at joint connector (CAN1) C-105.**

- (1) Disconnect joint connector (CAN1), and check that there is continuity at the harness side of joint connector (CAN1).
- (2) Check that there is continuity between joint connector (CAN1) terminals 5 and 16.

**OK: No continuity**

**Q: Is the check result normal?**

**YES (vehicles without satellite radio) :** Go to Step 36.

**YES (vehicles with satellite radio) :** Go to Step 35.

**NO :** Go to Step 56.

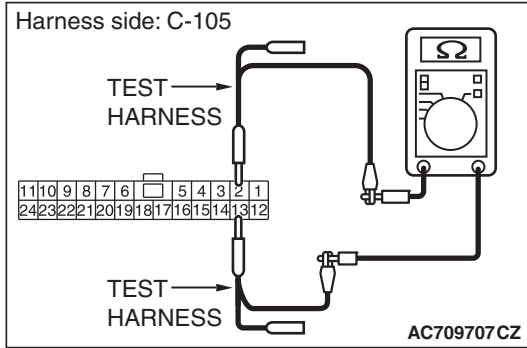

**STEP 35. Check the wiring harness between joint connector (CAN1) C-105 and satellite radio tuner connector C-18 for line-to-line short. Measure the resistance at joint connector (CAN1) C-105.**

- (1) Disconnect joint connector (CAN1), and check that there is continuity at the harness side of joint connector (CAN1).
- (2) Check that there is continuity between joint connector (CAN1) terminals 2 and 13.

**OK: No continuity**

**Q: Is the check result normal?**

**YES :** Go to Step 36.

**NO :** Go to Step 57.

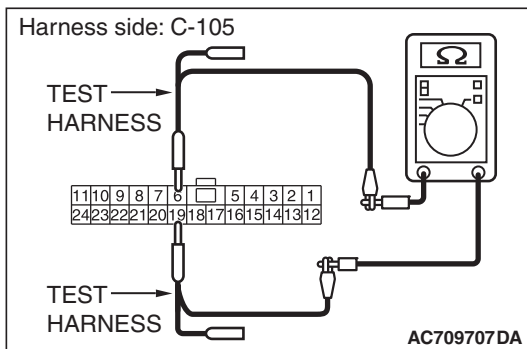

**STEP 36. Check the wiring harness between joint connector (CAN1) C-105 and EATCS-ECU connector C-301 for line-to-line short. Measure the resistance at joint connector (CAN1) C-105.**

- (1) Disconnect joint connector (CAN1) and ETACS-ECU connector C-301, and check that there is continuity at the harness side of joint connector (CAN1).
- (2) Check that there is continuity between joint connector (CAN1) terminals 6 and 19.

**OK: No continuity**

**Q: Is the check result normal?**

**YES :** Go to Step 58.

**NO :** Repair the wiring harness between joint connector (CAN1) C-105 and ETACS-ECU connector C-301.

**STEP 37. Check the wiring harness between joint connector (CAN1) C-105 and combination meter connector C-04 for open circuit.**

**⚠ CAUTION**

**Strictly observe the specified wiring harness repair procedure. For details refer to P.54C-7.**

- (1) Disconnect joint connector (CAN1) C-105 and combination meter connector C-301, and check the wiring harness.
- (2) Check the wiring harness between joint connector (CAN1) C-105 (terminal 3) and combination meter connector C-04 (terminal 14)

**OK: Continuity exists (2 Ω or less)**

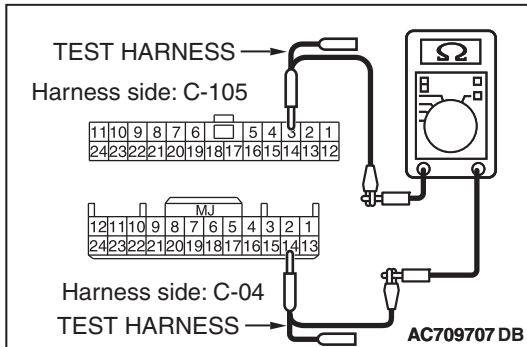

- (3) Check the wiring harness between joint connector (CAN1) C-105 (terminal 14) and combination meter connector C-04 (terminal 15)

**OK: Continuity exists (2 Ω or less)**

**Q: Is the wiring harness between joint connector (CAN1) C-105 and combination meter connector C-04 in good condition?**

**YES (vehicles with KOS) :** Go to Step 38.

**YES (vehicles with WCM) :** Go to Step 39.

**NO ((vehicles with KOS or WCM) :** Go to Step 48.

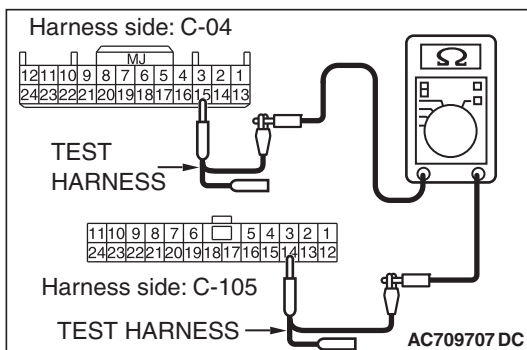

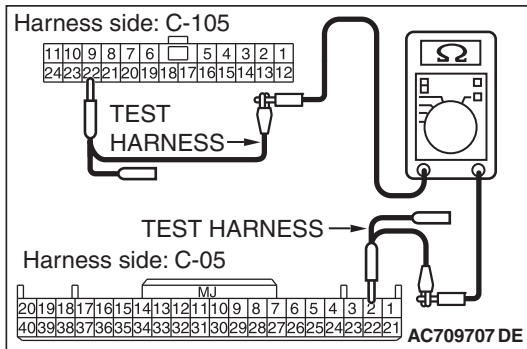
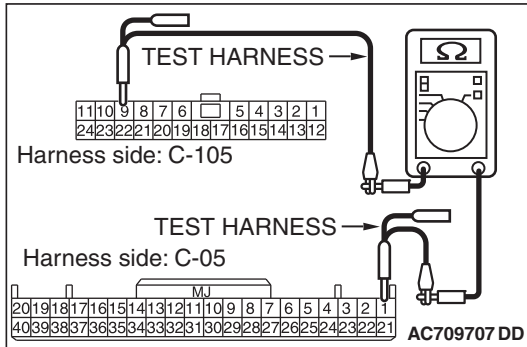

**STEP 38. Check the wiring harness between joint connector (CAN1) C-105 and KOS-ECU connector C-05 for open circuit.**

- (1) Disconnect joint connector (CAN1) C-105 and KOS-ECU connector C-05, and check the wiring harness.
- (2) Check the wiring harness between joint connector (CAN1) C-105 (terminal 9) and KOS-ECU connector C-05 (terminal 1)

**OK: Continuity exists (2  $\Omega$  or less)**

- (3) Check the wiring harness between joint connector (CAN1) C-105 (terminal 22) and KOS-ECU connector C-05 (terminal 2)

**OK: Continuity exists (2  $\Omega$  or less)**

**Q: Is the wiring harness between joint connector (CAN1) C-105 and KOS-ECU connector C-05 in good condition?**

**YES :** Go to Step 40.

**NO :** Go to Step 49.

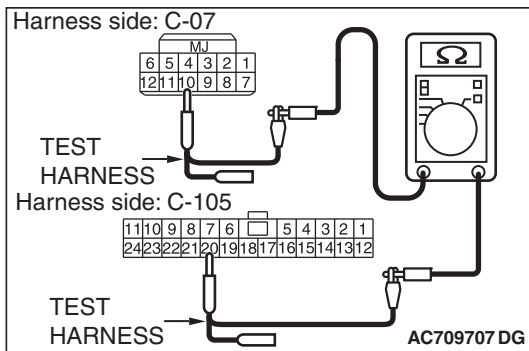
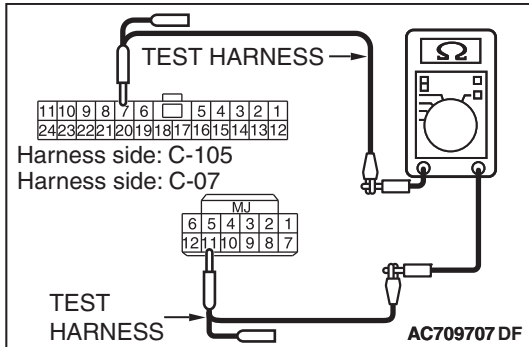

**STEP 39. Check the wiring harness between joint connector (CAN1) C-105 and WCM connector C-07 for open circuit.**

- (1) Disconnect joint connector (CAN1) C-105 and WCM connector C-07, and check the wiring harness.
- (2) Check the wiring harness between joint connector (CAN1) C-105 (terminal 7) and WCM connector C-07 (terminal 11)

**OK: Continuity exists (2  $\Omega$  or less)**

- (3) Check the wiring harness between joint connector (CAN1) C-105 (terminal 20) and WCM connector C-07 (terminal 10)

**OK: Continuity exists (2  $\Omega$  or less)**

**Q: Is the wiring harness between joint connector (CAN1) C-105 and WCM connector C-07 in good condition?**

**YES :** Go to Step 40.

**NO :** Go to Step 50.

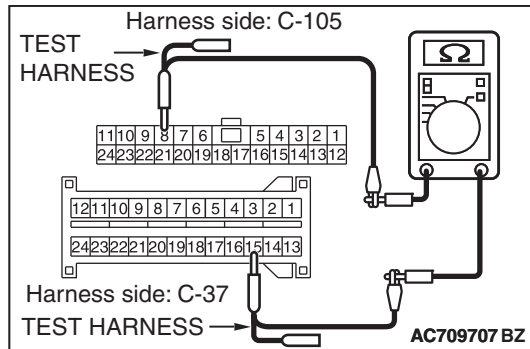

**STEP 40. Check the wiring harness between joint connector (CAN1) C-105 and SRS-ECU connector C-37 for open circuit.**

- (1) Disconnect joint connector (CAN1) C-105 and SRS-ECU connector C-37, and check the wiring harness.
- (2) Check the wiring harness between joint connector (CAN1) C-105 (terminal 8) and SRS-ECU connector C-37 (terminal 15)

**OK: Continuity exists (2 Ω or less)**

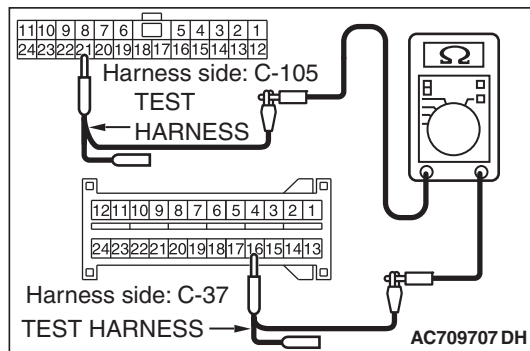

- (3) Check the wiring harness between joint connector (CAN1) C-105 (terminal 21) and SRS-ECU connector C-37 (terminal 16)

**OK: Continuity exists (2 Ω or less)**

**Q: Is the wiring harness between joint connector (CAN1) C-105 and SRS-ECU connector C-37 in good condition?**

**YES :** Go to Step 41.

**NO :** Go to Step 51.



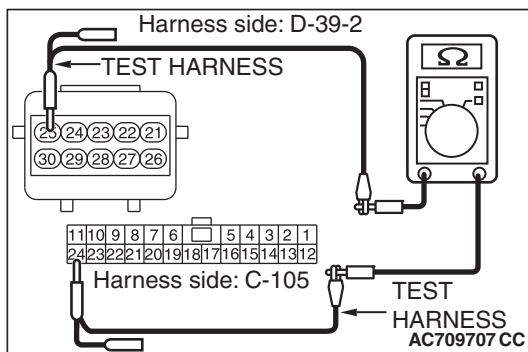
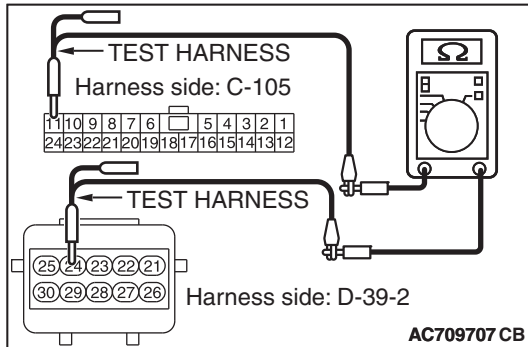

**STEP 41. Check the wiring harness between joint connector (CAN1) C-105 and occupant classification-ECU connector D-39-2 for open circuit.**

- (1) Disconnect joint connector (CAN1) C-105 and occupant classification-ECU connector D-39-2, and check the wiring harness.
- (2) Check the wiring harness between joint connector (CAN1) C-105 (terminal 11) and occupant classification-ECU connector D-39-2 (terminal 24)

**OK: Continuity exists (2 Ω or less)**

- (3) Check the wiring harness between joint connector (CAN1) C-105 (terminal 24) and occupant classification-ECU connector D-39-2 (terminal 25)

**OK: Continuity exists (2 Ω or less)**

*NOTE: Prior to the wiring harness inspection, check intermediate connector C-41 and front seat assembly (LH) connector D-39, and repair if necessary.*

**Q: Is the wiring harness between joint connector (CAN1) C-105 and occupant classification-ECU connector D-39-2 in good condition?**

**YES (vehicles without hands free system) :** Go to Step 43.

**YES (vehicles with hands free system) :** Go to Step 42.

**NO :** Go to Step 52.

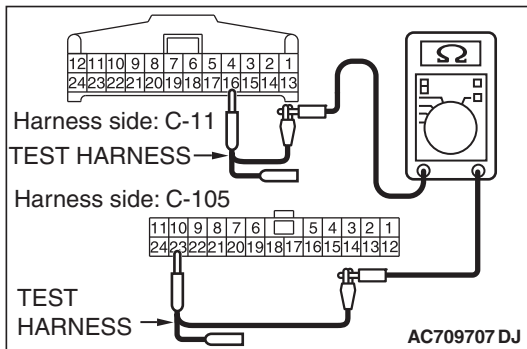
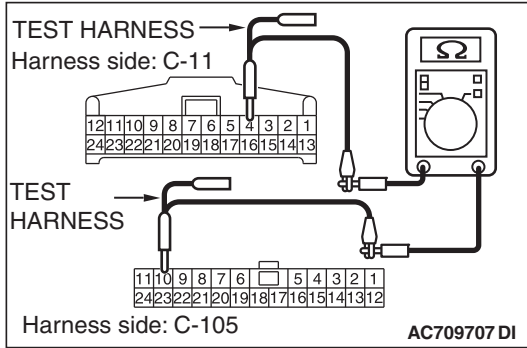

**STEP 42. Check the wiring harness between joint connector (CAN1) C-105 and hands free module connector C-11 for open circuit.**

- (1) Disconnect joint connector (CAN1) C-105 and occupant hands free module connector C-11, and check the wiring harness.
- (2) Check the wiring harness between joint connector (CAN1) C-105 (terminal 10) and hands free module connector C-11 (terminal 4)

**OK: Continuity exists (2 Ω or less)**

- (3) Check the wiring harness between joint connector (CAN1) C-105 (terminal 23) and hands free module connector C-11 (terminal 16)

**OK: Continuity exists (2 Ω or less)**

**Q: Is the wiring harness between joint connector (CAN1) C-105 and hands free module connector C-11 in good condition?**

**YES :** Go to Step 43.

**NO :** Go to Step 53.

**STEP 43. Check the wiring harness between joint connector (CAN1) C-105 and A/C-ECU connector C-22 <vehicles with A/C> or heater control unit connector C-53 <vehicles without A/C> for open circuit.**

(1) Disconnect joint connector (CAN1) C-105 and A/C-ECU connector C-22 <vehicles with A/C> or heater control unit connector C-53 <vehicles without A/C>, and check the wiring harness.

(2) Check the wiring harness between joint connector (CAN1) C-105 (terminal 1) and A/C-ECU connector C-22 <vehicles with A/C> or heater control unit connector C-53 <vehicles without A/C> (terminal 11)

**OK: Continuity exists (2 Ω or less)**

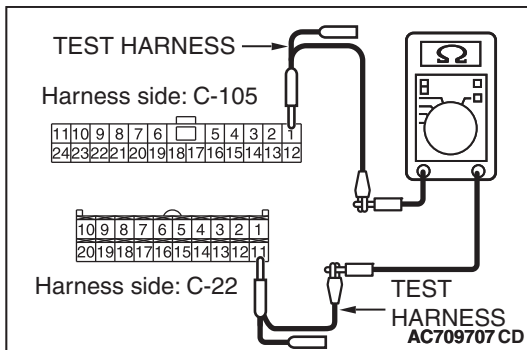

(3) Check the wiring harness between joint connector (CAN1) C-105 (terminal 12) and A/C-ECU connector C-22 <vehicles with A/C> or heater control unit connector C-53 <vehicles without A/C> (terminal 12)

**OK: Continuity exists (2 Ω or less)**

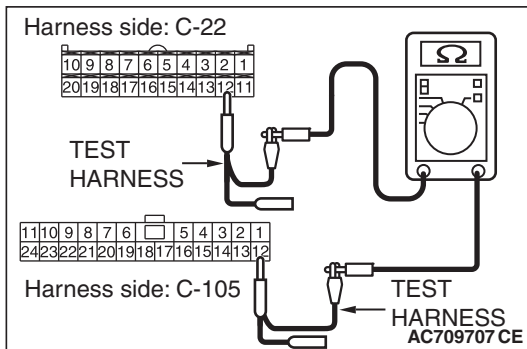

**Q: Is the wiring harness between joint connector (CAN1) C-105 and A/C-ECU connector C-22 <vehicles with A/C> or heater control unit connector C-53 <vehicles without A/C> in good condition?**

**YES (vehicles without MMCS) :** Go to Step 44.

**YES (vehicles with MMCS) :** Go to Step 45.

**NO :** Go to Step 54.

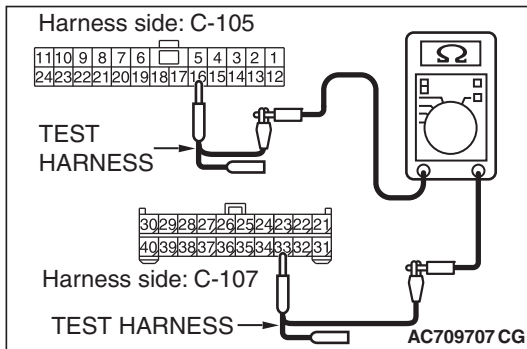
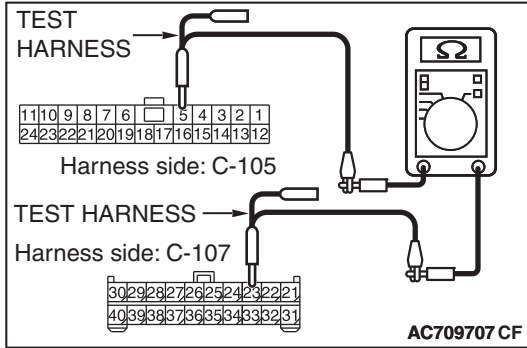

**STEP 44. Check the wiring harness between joint connector (CAN1) C-105 and radio and CD player or CD changer connector C-107 for open circuit.**

- (1) Disconnect joint connector (CAN1) C-105 and radio and CD player or CD changer connector C-107, and check the wiring harness.
- (2) Check the wiring harness between joint connector (CAN1) C-105 (terminal 5) and radio and CD player or CD changer connector C-107 (terminal 23)

**OK: Continuity exists (2 Ω or less)**

- (3) Check the wiring harness between joint connector (CAN1) C-105 (terminal 16) and radio and CD player or CD changer connector C-107 (terminal 33)

**OK: Continuity exists (2 Ω or less)**

**Q: Is the wiring harness between joint connector (CAN1) C-105 and radio and CD player or CD changer connector C-107 in good condition?**

**YES (vehicles without satellite radio) :** Go to Step 47.

**YES (vehicles with satellite radio) :** Go to Step 46.

**NO :** Go to Step 55.

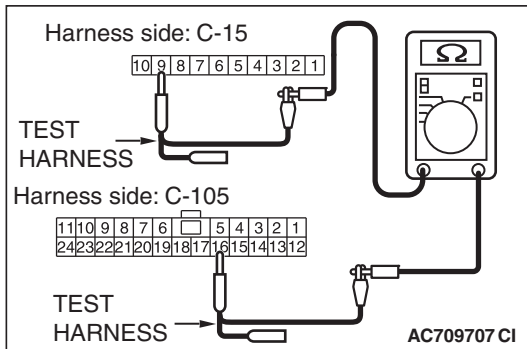
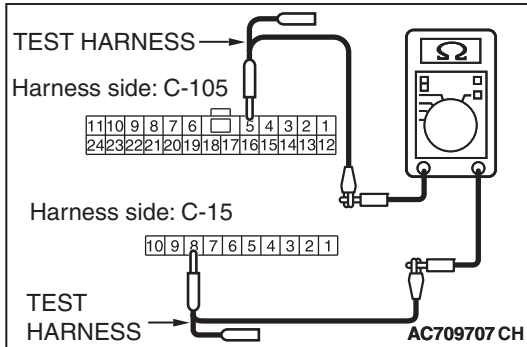

**STEP 45. Check the wiring harness between joint connector (CAN1) C-105 and CAN box unit connector C-15 for open circuit.**

- (1) Disconnect joint connector (CAN1) C-105 and CAN box unit connector C-15, and check the wiring harness.
- (2) Check the wiring harness between joint connector (CAN1) C-105 (terminal 5) and CAN box unit connector C-15 (terminal 8)

**OK: Continuity exists (2 Ω or less)**

- (3) Check the wiring harness between joint connector (CAN1) C-105 (terminal 16) and CAN box unit connector C-15 (terminal 9)

**OK: Continuity exists (2 Ω or less)**

*NOTE: Prior to the wiring harness inspection, check intermediate connector C-108, and repair if necessary.*

**Q: Is the wiring harness between joint connector (CAN1) C-105 and CAN box unit connector C-15 in good condition?**

**YES (vehicles without satellite radio) :** Go to Step 47.

**YES (vehicles with satellite radio) :** Go to Step 46.

**NO :** Go to Step 56.

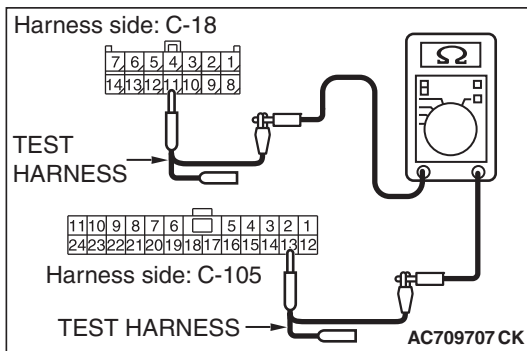
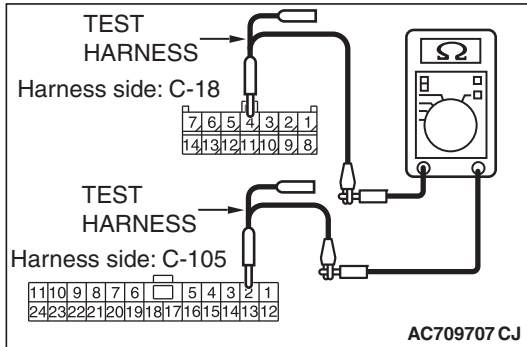

**STEP 46. Check the wiring harness between joint connector (CAN1) C-105 and satellite radio tuner connector C-18 for open circuit.**

- (1) Disconnect joint connector (CAN1) C-105 and satellite radio tuner connector C-18, and check the wiring harness.
- (2) Check the wiring harness between joint connector (CAN1) C-105 (terminal 2) and satellite radio tuner connector C-18 (terminal 4)

**OK: Continuity exists (2 Ω or less)**

- (3) Check the wiring harness between joint connector (CAN1) C-105 (terminal 13) and satellite radio tuner connector C-18 (terminal 11)

**OK: Continuity exists (2 Ω or less)**

**Q: Is the wiring harness between joint connector (CAN1) C-105 and satellite radio tuner connector C-18 in good condition?**

**YES :** Go to Step 47.

**NO :** Go to Step 57.

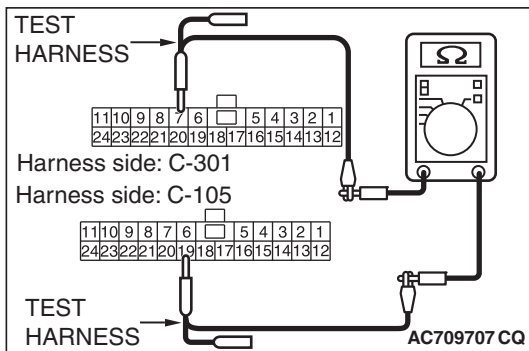
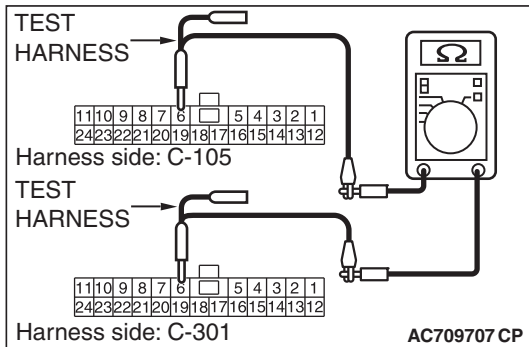

**STEP 47. Check the wiring harness between joint connector (CAN1) C-105 and ETACS-ECU connector C-301 for open circuit.**

- (1) Disconnect joint connector (CAN1) C-105 and ETACS-ECU connector C-301, and check the wiring harness.
- (2) Check the wiring harness between joint connector (CAN1) C-105 (terminal 6) and ETACS-ECU connector C-301 (terminal 6)

**OK: Continuity exists (2 Ω or less)**

- (3) Check the wiring harness between joint connector (CAN1) C-105 (terminal 19) and ETACS-ECU connector C-301 (terminal 7)

**OK: Continuity exists (2 Ω or less)**

**Q: Is the wiring harness between joint connector (CAN1) C-105 and ETACS-ECU connector C-301 in good condition?**

**YES :** Go to Step 58.

**NO :** Repair the wiring harness between joint connector (CAN1) C-105 and ETACS-ECU connector C-301.

**STEP 48.** Using scan tool MB991958, diagnose the CAN bus line. (checking the combination meter for internal failure)

**⚠ CAUTION**

Strictly observe the specified wiring harness repair procedure. For details refer to [P.54C-7](#).

**⚠ CAUTION**

To prevent damage to scan tool MB991958, always turn the ignition switch to the "LOCK" (OFF) position before connecting or disconnecting scan tool MB991958.

- (1) Disconnect combination meter connector C-04.
- (2) Connect scan tool MB991958 to the data link connector.
- (3) Turn the ignition switch to the "ON" position.

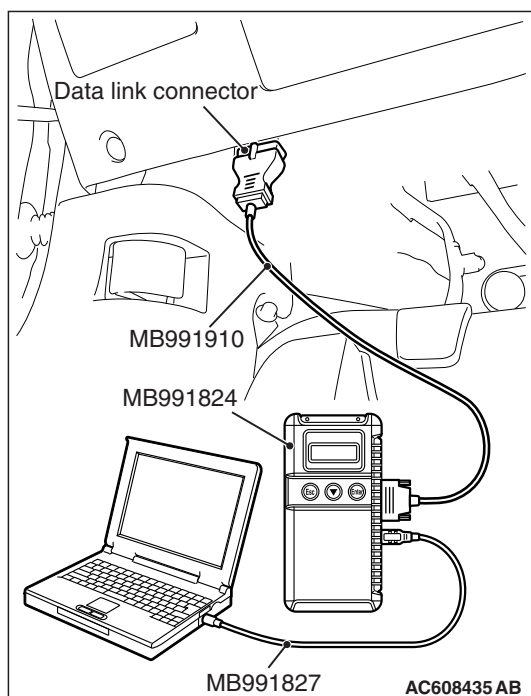



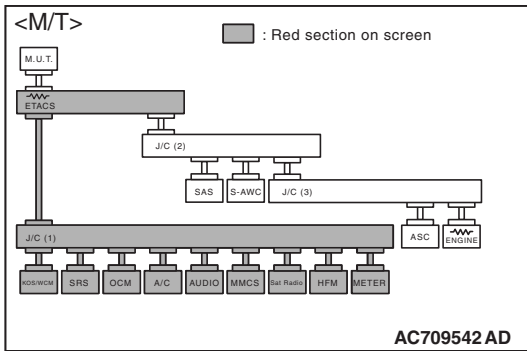

(4) Diagnose CAN bus lines, and check if the scan tool MB991958 screen is as shown in the figure.

**OK:** The display of the scan tool MB991958 is as shown in the figure.

**Q:** Does scan tool MB991958 screen correspond to the illustration?

**YES :** Repair the wiring harness between joint connector (CAN1) C-105 and combination meter connector C-04.

**NO :** Check combination meter connector C-04, and repair if necessary. If the combination meter connector is in good condition, replace the combination meter.

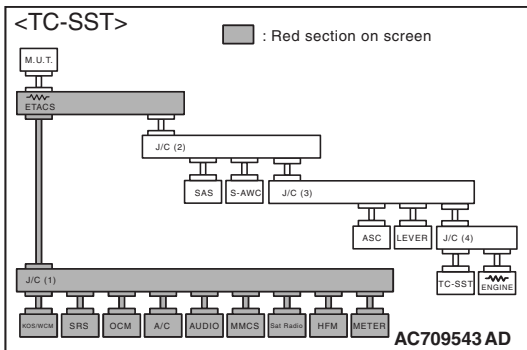

**STEP 49.** Using scan tool MB991958, diagnose the CAN bus line. (checking the KOS-ECU for internal failure)

**⚠ CAUTION**

Strictly observe the specified wiring harness repair procedure. For details refer to [P.54C-7](#).

**⚠ CAUTION**

To prevent damage to scan tool MB991958, always turn the ignition switch to the "LOCK" (OFF) position before connecting or disconnecting scan tool MB991958.

- (1) Disconnect KOS-ECU connector C-05.
- (2) Connect scan tool MB991958 to the data link connector.
- (3) Turn the ignition switch to the "ON" position.

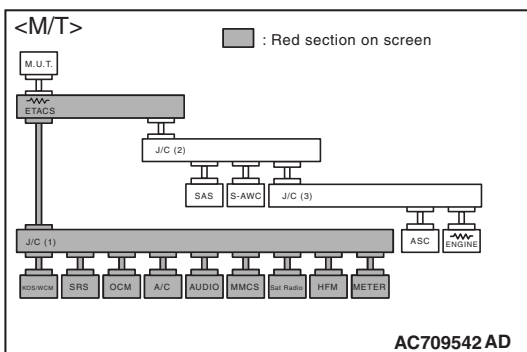
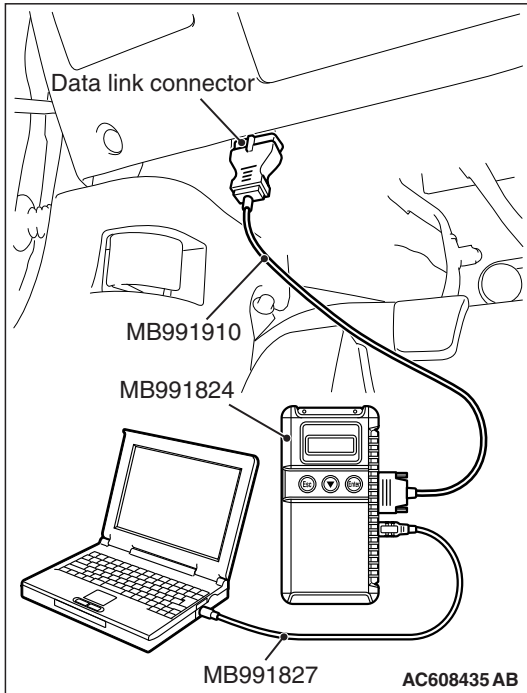

- (4) Diagnose CAN bus lines, and check if the scan tool MB991958 screen is as shown in the figure.

**OK:** The display of the scan tool MB991958 is as shown in the figure.

**Q:** Does scan tool MB991958 screen correspond to the illustration?

**YES :** Repair the wiring harness between joint connector (CAN1) C-105 and KOS-ECU connector C-05.

**NO :** Check KOS-ECU connector C-05, and repair if necessary. If the KOS-ECU connector is in good condition, replace the KOS-ECU.

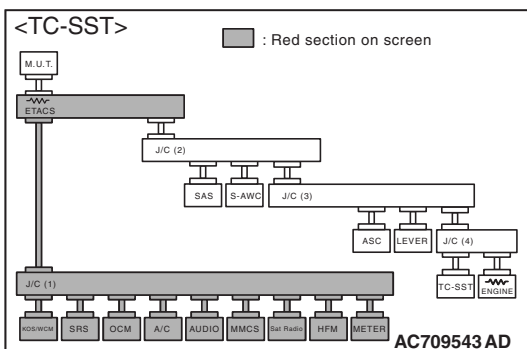

**STEP 50.** Using scan tool MB991958, diagnose the CAN bus line. (checking the WCM for internal failure)

**⚠ CAUTION**

Strictly observe the specified wiring harness repair procedure. For details refer to [P.54C-7](#).

**⚠ CAUTION**

To prevent damage to scan tool MB991958, always turn the ignition switch to the "LOCK" (OFF) position before connecting or disconnecting scan tool MB991958.

- (1) Disconnect WCM connector C-07.
- (2) Connect scan tool MB991958 to the data link connector.
- (3) Turn the ignition switch to the "ON" position.

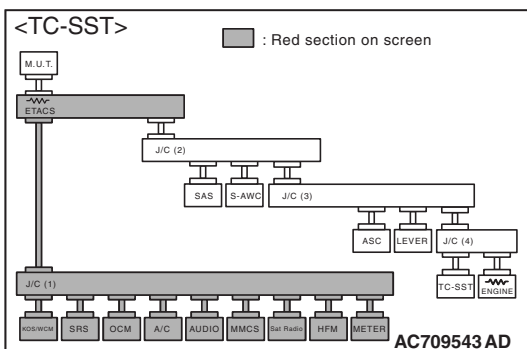
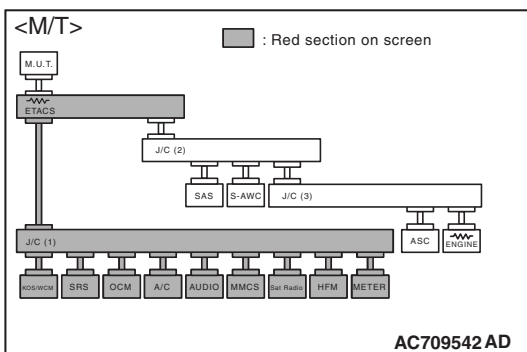
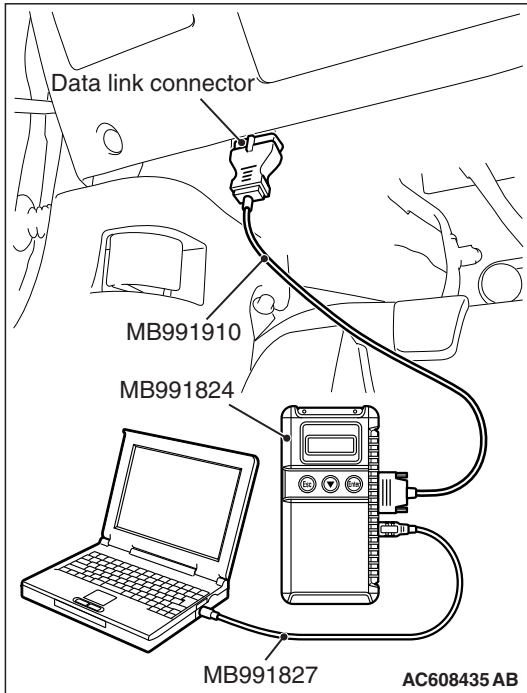

- (4) Diagnose CAN bus lines, and check if the scan tool MB991958 screen is as shown in the figure.

**OK:** The display of the scan tool MB991958 is as shown in the figure.

**Q:** Does scan tool MB991958 screen correspond to the illustration?

**YES :** Repair the wiring harness between joint connector (CAN1) C-105 and WCM connector C-07.

**NO :** Check WCM connector C-07, and repair if necessary. If the WCM connector is in good condition, replace the WCM.

**STEP 51.** Using scan tool MB991958, diagnose the CAN bus line. (checking the SRS-ECU for internal failure)

**⚠ CAUTION**

Strictly observe the specified wiring harness repair procedure. For details refer to [P.54C-7](#).

**⚠ CAUTION**

To prevent damage to scan tool MB991958, always turn the ignition switch to the "LOCK" (OFF) position before connecting or disconnecting scan tool MB991958.

- (1) Disconnect SRS-ECU connector C-37.
- (2) Connect scan tool MB991958 to the data link connector.
- (3) Turn the ignition switch to the "ON" position.

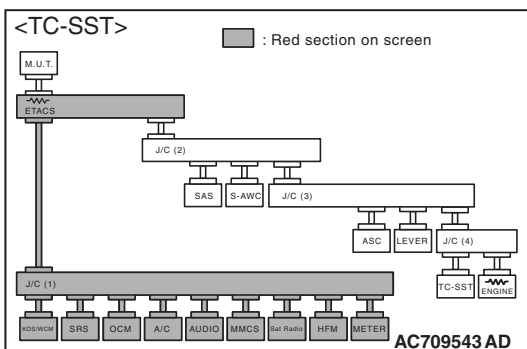
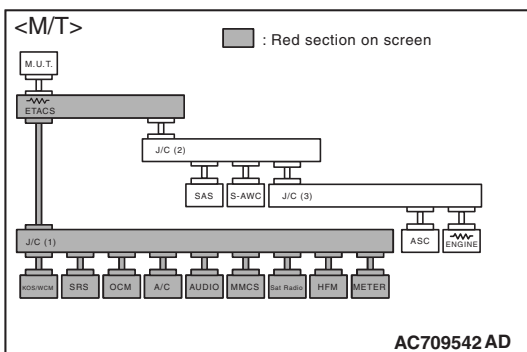
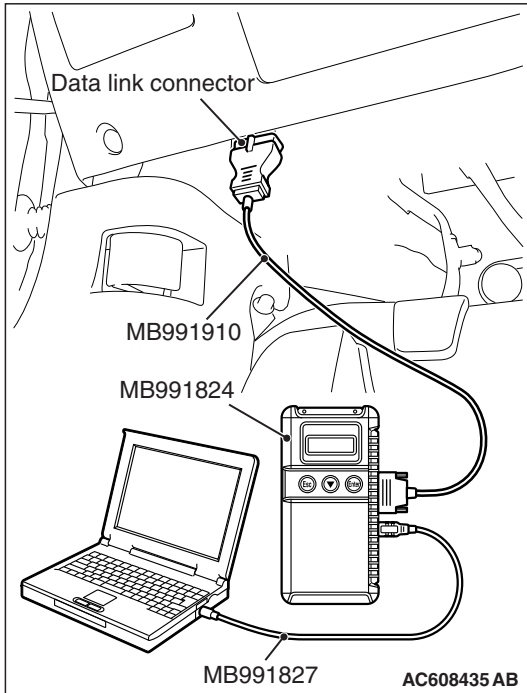

- (4) Diagnose CAN bus lines, and check if the scan tool MB991958 screen is as shown in the figure.

**OK:** The display of the scan tool MB991958 is as shown in the figure.

**Q:** Does scan tool MB991958 screen correspond to the illustration?

**YES :** Repair the wiring harness between joint connector (CAN1) C-105 and SRS-ECU connector C-37.

**NO :** Check SRS-ECU connector C-37, and repair if necessary. If the SRS-ECU connector is in good condition, replace the SRS-ECU.

**STEP 52.** Using scan tool MB991958, diagnose the CAN bus line. (checking the occupant classification-ECU for internal failure)

**⚠ CAUTION**

Strictly observe the specified wiring harness repair procedure. For details refer to [P.54C-7](#).

**⚠ CAUTION**

To prevent damage to scan tool MB991958, always turn the ignition switch to the "LOCK" (OFF) position before connecting or disconnecting scan tool MB991958.

- (1) Disconnect occupant classification-ECU connector D-39-2.
- (2) Connect scan tool MB991958 to the data link connector.
- (3) Turn the ignition switch to the "ON" position.

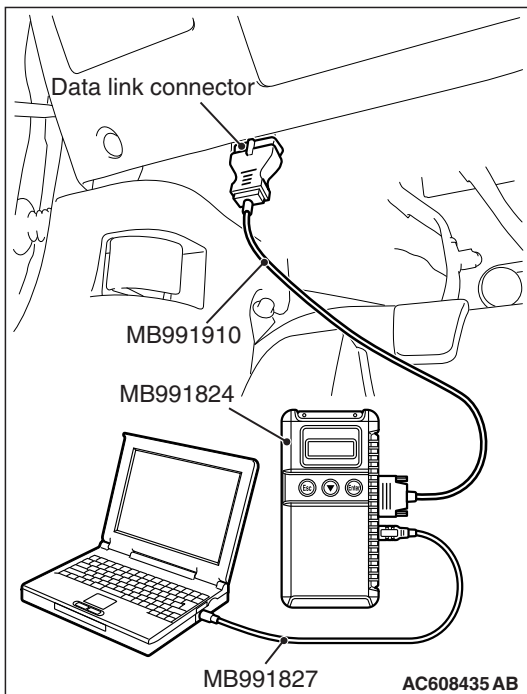

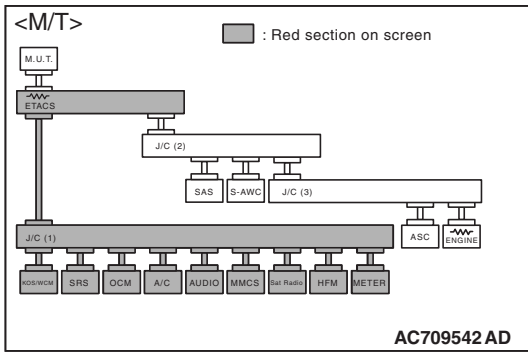

(4) Diagnose CAN bus lines, and check if the scan tool MB991958 screen is as shown in the figure.

**OK:** The display of the scan tool MB991958 is as shown in the figure.

**Q:** Does scan tool MB991958 screen correspond to the illustration?

**YES :** Repair the wiring harness between joint connector (CAN1) C-105 and occupant classification-ECU connector D-39-2.

**NO :** Check occupant classification-ECU connector D-39-2, and repair if necessary. If the occupant classification-ECU connector is in good condition, replace the occupant classification-ECU.

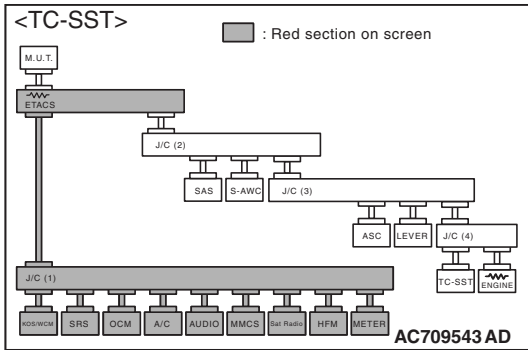

**STEP 53.** Using scan tool MB991958, diagnose the CAN bus line. (checking the hands free module for internal failure)

**⚠ CAUTION**

Strictly observe the specified wiring harness repair procedure. For details refer to [P.54C-7](#).

**⚠ CAUTION**

To prevent damage to scan tool MB991958, always turn the ignition switch to the "LOCK" (OFF) position before connecting or disconnecting scan tool MB991958.

- (1) Disconnect hands free module connector C-11.
- (2) Connect scan tool MB991958 to the data link connector.
- (3) Turn the ignition switch to the "ON" position.

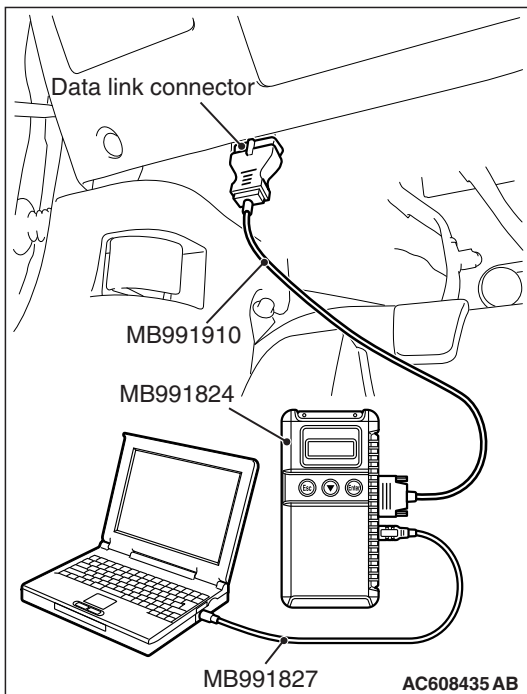

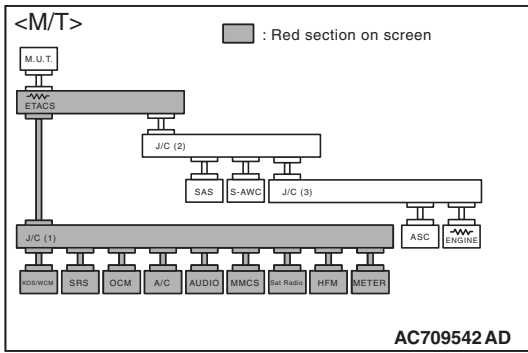

(4) Diagnose CAN bus lines, and check if the scan tool MB991958 screen is as shown in the figure.

**OK:** The display of the scan tool MB991958 is as shown in the figure.

**Q:** Does scan tool MB991958 screen correspond to the illustration?

**YES :** Repair the wiring harness between joint connector (CAN1) C-105 and hands free module connector C-11.

**NO :** Check hands free module connector C-11, and repair if necessary. If the hands free module connector is in good condition, replace the hands free module.

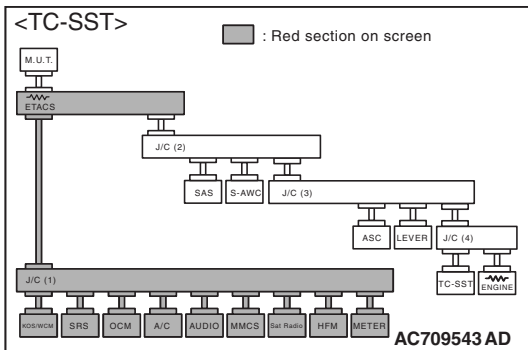



**STEP 54.** Using scan tool MB991958, diagnose the CAN bus line. (checking the A/C-ECU <vehicles with A/C> or heater control unit <vehicles without A/C> for internal failure)

**⚠ CAUTION**

Strictly observe the specified wiring harness repair procedure. For details refer to [P.54C-7](#).

**⚠ CAUTION**

To prevent damage to scan tool MB991958, always turn the ignition switch to the "LOCK" (OFF) position before connecting or disconnecting scan tool MB991958.

- (1) Disconnect A/C-ECU connector C-22 <vehicles with A/C> or heater control unit connector C-53 <vehicles without A/C>.
- (2) Connect scan tool MB991958 to the data link connector.
- (3) Turn the ignition switch to the "ON" position.

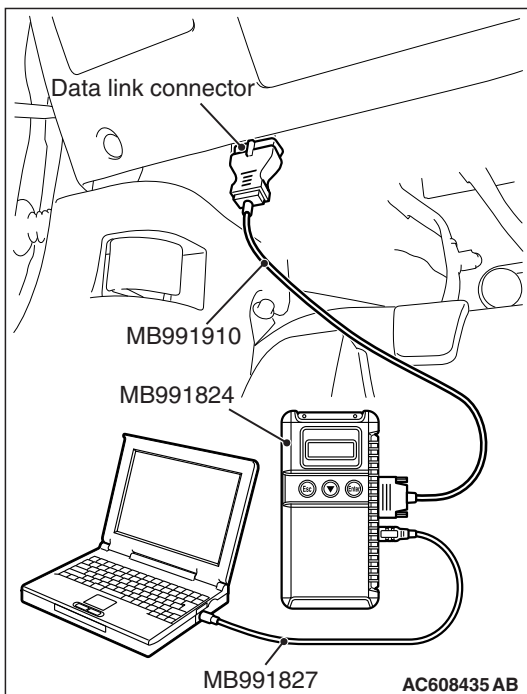

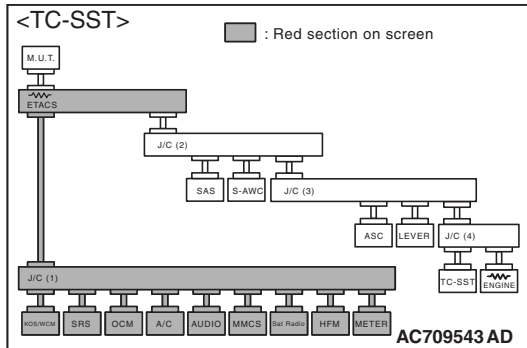
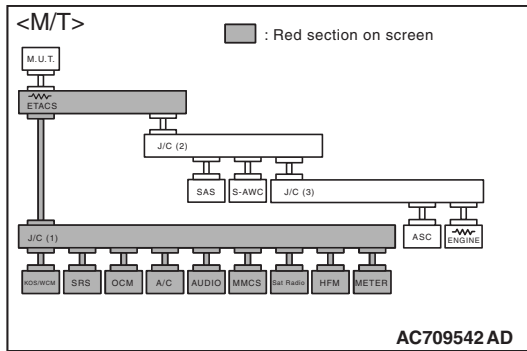

- (4) Diagnose CAN bus lines, and check if the scan tool MB991958 screen is as shown in the figure.

**OK:** The display of the scan tool MB991958 is as shown in the figure.

- Q:** Does scan tool MB991958 screen correspond to the illustration?

**YES :** Repair the wiring harness between joint connector (CAN1) C-105 and A/C-ECU connector C-22 <vehicles with A/C> or heater control unit connector C-53 <vehicles without A/C>.

**NO :** Check A/C-ECU connector C-22 <vehicles with A/C> or heater control unit connector C-53 <vehicles without A/C>, and repair if necessary. If the A/C-ECU connector <vehicles with A/C> or heater control unit connector <vehicles without A/C> is in good condition, replace the A/C-ECU <vehicles with A/C> or heater control unit <vehicles without A/C>.

**STEP 55.** Using scan tool MB991958, diagnose the CAN bus line. (checking the radio and CD player or CD changer for internal failure)

**⚠ CAUTION**

Strictly observe the specified wiring harness repair procedure. For details refer to [P.54C-7](#).

**⚠ CAUTION**

To prevent damage to scan tool MB991958, always turn the ignition switch to the "LOCK" (OFF) position before connecting or disconnecting scan tool MB991958.

- (1) Disconnect radio and CD player or CD changer connector C-107.
- (2) Connect scan tool MB991958 to the data link connector.
- (3) Turn the ignition switch to the "ON" position.

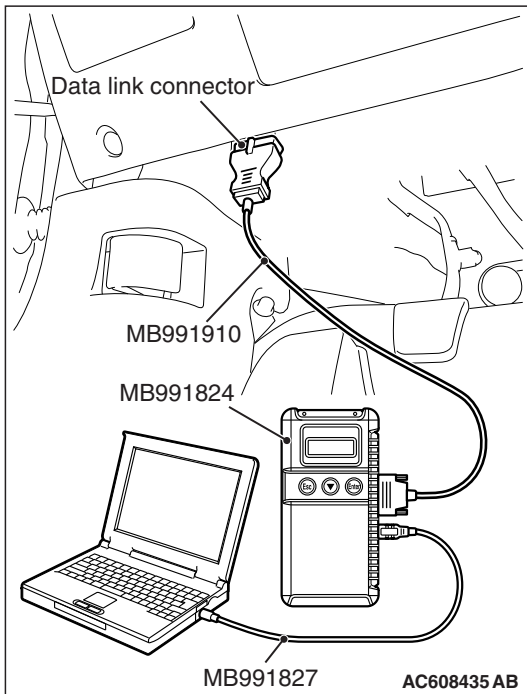

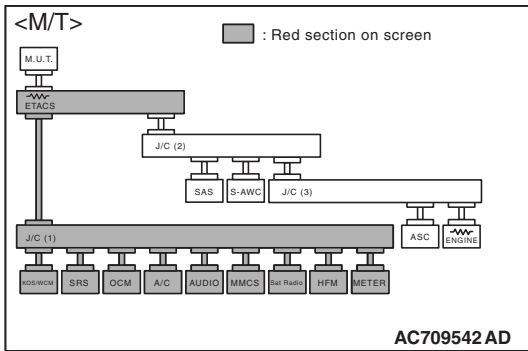

(4) Diagnose CAN bus lines, and check if the scan tool MB991958 screen is as shown in the figure.

**OK:** The display of the scan tool MB991958 is as shown in the figure.

**Q:** Does scan tool MB991958 screen correspond to the illustration?

**YES :** Repair the wiring harness between joint connector (CAN1) C-105 and radio and CD player or CD changer connector C-107.

**NO :** Check radio and CD player or CD changer connector C-107, and repair if necessary. If the radio and CD player or CD changer connector is in good condition, replace the radio and CD player or CD changer.

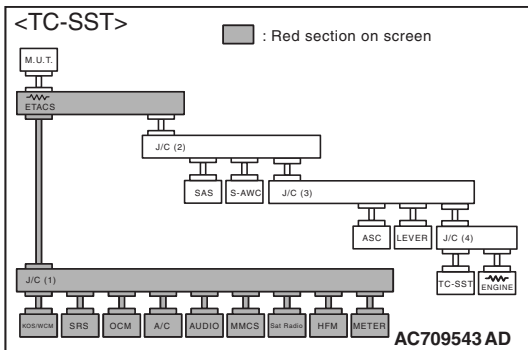

**STEP 56.** Using scan tool MB991958, diagnose the CAN bus line. (checking the CAN box unit for internal failure)

**⚠ CAUTION**

Strictly observe the specified wiring harness repair procedure. For details refer to [P.54C-7](#).

**⚠ CAUTION**

To prevent damage to scan tool MB991958, always turn the ignition switch to the "LOCK" (OFF) position before connecting or disconnecting scan tool MB991958.

- (1) Disconnect CAN box unit connector C-15.
- (2) Connect scan tool MB991958 to the data link connector.
- (3) Turn the ignition switch to the "ON" position.

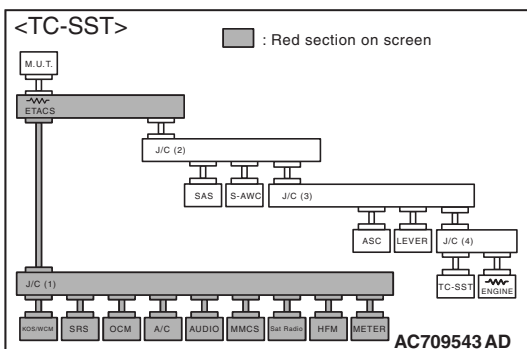
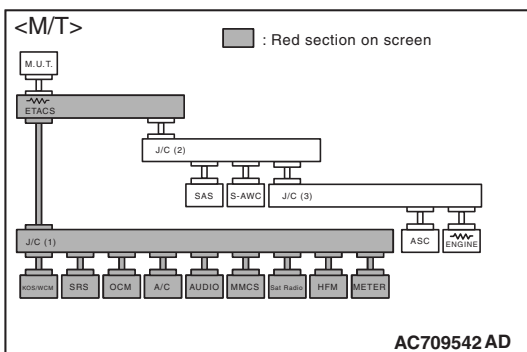
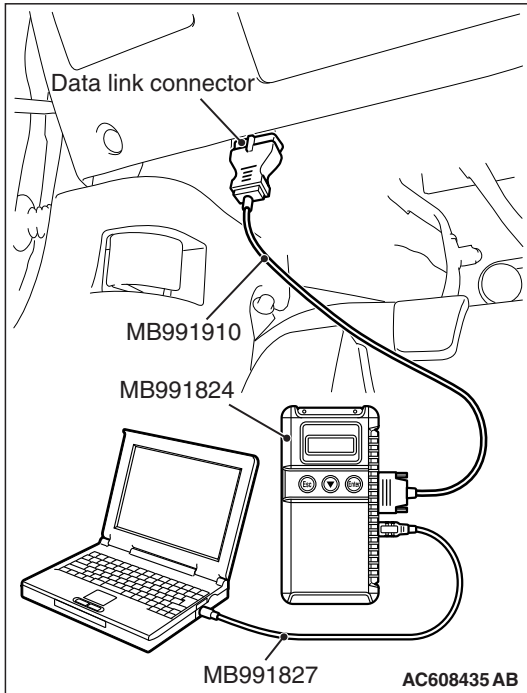

- (4) Diagnose CAN bus lines, and check if the scan tool MB991958 screen is as shown in the figure.

**OK:** The display of the scan tool MB991958 is as shown in the figure.

**Q:** Does scan tool MB991958 screen correspond to the illustration?

**YES :** Repair the wiring harness between joint connector (CAN1) C-105 and CAN box unit connector C-15.

**NO :** Check CAN box unit connector C-15, and repair if necessary. If the CAN box unit connector is in good condition, replace the CAN box unit.

**STEP 57.** Using scan tool MB991958, diagnose the CAN bus line. (checking the satellite radio tuner for internal failure)

**⚠ CAUTION**

Strictly observe the specified wiring harness repair procedure. For details refer to [P.54C-7](#).

**⚠ CAUTION**

To prevent damage to scan tool MB991958, always turn the ignition switch to the "LOCK" (OFF) position before connecting or disconnecting scan tool MB991958.

- (1) Disconnect satellite radio tuner connector C-18.
- (2) Connect scan tool MB991958 to the data link connector.
- (3) Turn the ignition switch to the "ON" position.

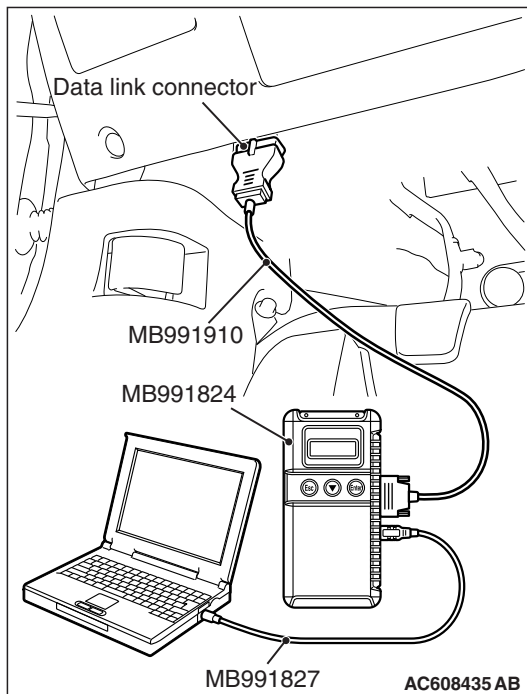

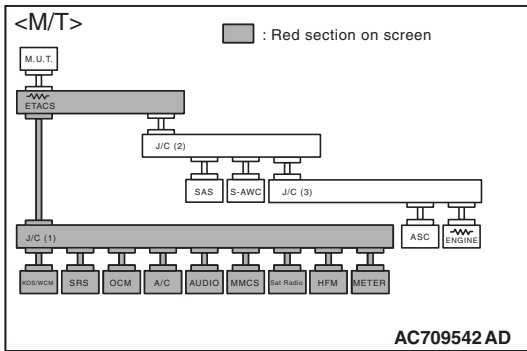

(4) Diagnose CAN bus lines, and check if the scan tool MB991958 screen is as shown in the figure.

**OK:** The display of the scan tool MB991958 is as shown in the figure.

**Q:** Does scan tool MB991958 screen correspond to the illustration?

**YES :** Repair the wiring harness between joint connector (CAN1) C-105 and satellite radio tuner connector C-18.

**NO :** Check satellite radio tuner connector C-18, and repair if necessary. If the satellite radio tuner connector is in good condition, replace the satellite radio tuner.

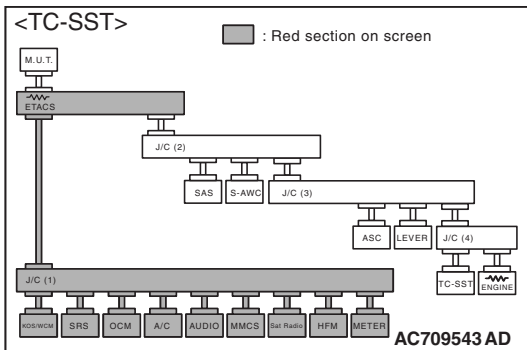

**STEP 58. Using scan tool MB991958, diagnose the CAN bus line. (trouble symptom check)**

**⚠ CAUTION**

Strictly observe the specified wiring harness repair procedure. For details refer to [P.54C-7](#).

**⚠ CAUTION**

To prevent damage to scan tool MB991958, always turn the ignition switch to the "LOCK" (OFF) position before connecting or disconnecting scan tool MB991958.

- (1) Connect scan tool MB991958 to the data link connector.
- (2) Turn the ignition switch to the "ON" position.

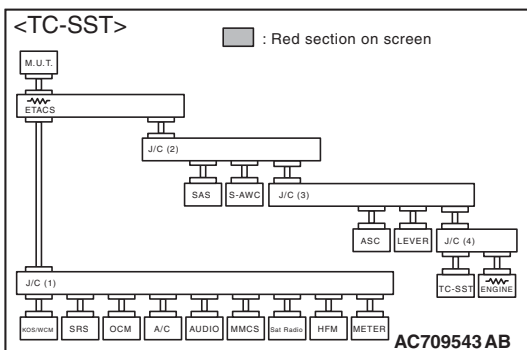
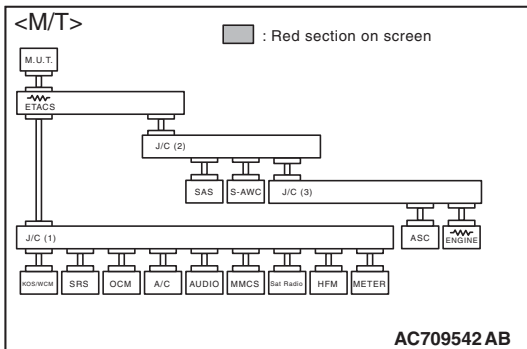
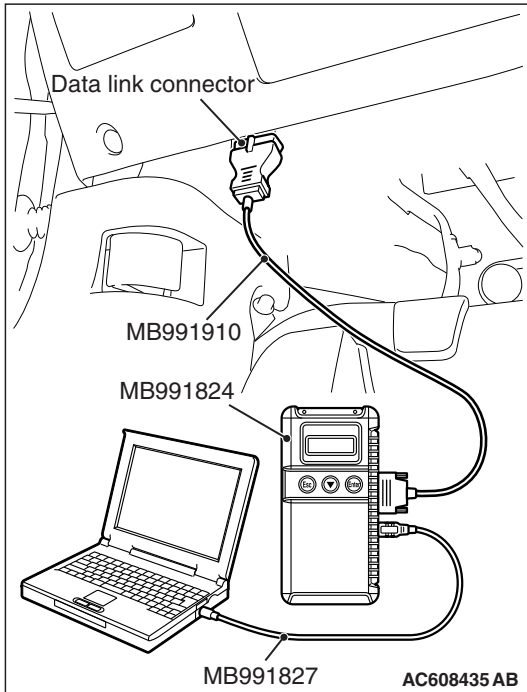

- (3) Diagnose CAN bus lines, and check if the scan tool MB991958 screen is as shown in the figure.

**OK:** The display of the scan tool MB991958 is as shown in the figure.

**Q:** Does scan tool MB991958 screen correspond to the illustration?

**YES :** The trouble can be an intermittent malfunction (Refer to GROUP 00, How to use Troubleshooting/inspection Service Points –How to Cope with Intermittent Malfunction [P.00-15](#)).

**NO :** Check the ETACS-ECU connector C-301, and repair if necessary. If the ETACS-ECU connector is in good condition, replace the ETACS-ECU.



## CAN COMMUNICATION-RELATED DTC (U-CODE) TABLE

M1548300300944

Code No.	Diagnostic item	Output ECU	Action
U0001	Bus Off (CAN-C)	ECM, S-AWC-ECU, TC-SST-ECU, Shift lever, ASC-ECU, ETACS-ECU	CAN main bus line diagnostics
U0019	Bus Off (CAN-B)	KOS-ECU or WCM, SRS-ECU, Combination meter, Radio and CD player or CD changer, CAN box unit, Hands-free module, Satellite radio tuner, ETACS-ECU, A/C-ECU	
U0020	CAN-B Bus off performance	Occupant classification-ECU	
U0021	CAN-B Bus (HI) circuit open		
U0022	CAN-B Bus (HI) shorted to circuit ground		
U0023	CAN-B Bus (HI) shorted to circuit power supply		
U0024	CAN-B Bus (LO) circuit open		
U0025	CAN-B Bus (LO) shorted to circuit ground		
U0026	CAN-B Bus (LO) shorted to circuit power supply		
U0100	Engine time-out	S-AWC-ECU, TC-SST-ECU, Shift lever, ASC-ECU, Combination meter, ETACS-ECU	
U0101	TC-SST time-out	ECM, S-AWC-ECU, Shift lever, ASC-ECU, ETACS-ECU	
U0103	Shift lever time-out	TC-SST-ECU, ETACS-ECU	
U0121	ASC-ECU time-out	ECM, S-AWC-ECU, TC-SST-ECU, Shift lever, ETACS-ECU	
U0125	G and yaw rate sensor message time-out error/message error	ASC-ECU	
U0126	Steering wheel sensor time-out	S-AWC-ECU, ASC-ECU, ETACS-ECU	
U0136	S-AWC-ECU time-out	TC-SST-ECU, ASC-ECU, ETACS-ECU	
U0141	ETACS-ECU time-out	ECM, S-AWC-ECU, TC-SST-ECU, Shift lever, ASC-ECU, KOS-ECU or WCM, SRS-ECU, Occupant classification-ECU, Combination meter, Radio and CD player or CD changer, CAN box unit, Hands-free module, Satellite radio tuner, A/C-ECU	

Code No.	Diagnostic item	Output ECU	Action
U0151	SRS time-out	KOS-ECU or WCM, Occupant classification-ECU, Combination meter, Radio and CD player or CD changer, CAN box unit, Hands-free module, Satellite radio tuner, ETACS-ECU, A/C-ECU	CAN main bus line diagnostics
U0154	Occupant Classification-ECU time-out	KOS-ECU or WCM, SRS-ECU, Combination meter, Radio and CD player or CD changer, CAN box unit, Hands-free module, Satellite radio tuner, ETACS-ECU, A/C-ECU	
U0155	Meter time-out	KOS-ECU or WCM, SRS-ECU, Occupant classification-ECU, Radio and CD player or CD changer, CAN box unit, Hands-free module, Satellite radio tuner, ETACS-ECU, A/C-ECU	
U0164	A/C time-out	KOS-ECU or WCM, SRS-ECU, Occupant classification-ECU, Combination meter, Radio and CD player or CD changer, CAN box unit, Hands-free module, Satellite radio tuner, ETACS-ECU	
U0167	CAN immobilizer (communication)	ECM	
U0168	WCM/KOS time-out	SRS-ECU, Occupant classification-ECU, Combination meter, Radio and CD player or CD changer, CAN box unit, Hands-free module, Satellite radio tuner, ETACS-ECU, A/C-ECU	
U0184	Audio unit time-out	KOS-ECU or WCM, SRS-ECU, Occupant classification-ECU, Combination meter, Hands-free module, Satellite radio tuner, ETACS-ECU, A/C-ECU	
U0195	Satellite radio tuner time-out	KOS-ECU or WCM, SRS-ECU, Occupant classification-ECU, Radio and CD player or CD changer, CAN box unit, Hands-free module, ETACS-ECU, A/C-ECU	
U0197	Hands free module time-out	KOS-ECU or WCM, SRS-ECU, Occupant classification-ECU, Combination meter, Radio and CD player or CD changer, CAN box unit, Satellite radio tuner, ETACS-ECU, A/C-ECU	
U0245	Audio visual navigation unit time-out	KOS-ECU or WCM, Occupant classification-ECU, Combination meter, Hands-free module, ETACS-ECU, A/C-ECU	

**CONTROLLER AREA NETWORK (CAN)  
CAN COMMUNICATION-RELATED DTC (U-CODE) TABLE**

**54C-271**

<b>Code No.</b>	<b>Diagnostic item</b>	<b>Output ECU</b>	<b>Action</b>
U0401	Engine malfunction detected	S-AWC-ECU, ASC-ECU	Diagnose CAN main bus lines and confirm input signals.
U0428	Communication error in steering wheel sensor		
U0431	ETACS malfunction detected	S-AWC-ECU	
U1003	G and yaw rate sensor bus-off	S-AWC-ECU, ASC-ECU	
U1108	Excess CAN-B ECU detection	ETACS-ECU	
U1120	Bus line (CAN-C) low input		
U1121	Bus line (CAN-C) high input		
U1180	Combination meter time-out	ECM	CAN main bus line diagnostics
U1412	Implausible vehicle speed signal received	KOS-ECU or WCM	Diagnose CAN main bus lines and confirm input signals.
U1414	Defective coding data	SRS-ECU	
U1415	Coding not completed/Data fail	S-AWC-ECU, ASC-ECU, KOS-ECU or WCM, SRS-ECU, Combination meter, Radio and CD player or CD changer, CAN box unit, A/C-ECU	
U1417	Implausible coding data	S-AWC-ECU, ASC-ECU, KOS-ECU or WCM, CAN box unit	

---

## NOTES