

GROUP 21A

CLUTCH

CONTENTS

GENERAL INFORMATION	21A-2	CLUTCH PEDAL AND MASTER CYLINDER	21A-4
SERVICE SPECIFICATIONS	21A-2	REMOVAL AND INSTALLATION	21A-4
LUBRICANTS	21A-2	INSPECTION	21A-7
ON-VEHICLE SERVICE	21A-2	CLUTCH SWITCH CHECK AND ADJUSTMENT	21A-7
CLUTCH PEDAL CHECK	21A-2	INTERLOCK SWITCH OPERATING CHECK	21A-8
CLUTCH BLEEDING	21A-3	CLUTCH CONTROL	21A-9
		REMOVAL AND INSTALLATION	21A-9
		INSPECTION	21A-10

GENERAL INFORMATION

M1211000100461

The clutch is a dry single-disk, diaphragm type; hydraulic pressure is used for the clutch control. The clutch shares a brake fluid reservoir with the brake system.

SERVICE SPECIFICATIONS

M1211000300692

Item	Standard value
Clutch pedal lateral play mm (in)	4 (0.16) or less
Clutch pedal free play mm (in)	4 -9 (0.16 -0.35)
Clutch pedal height mm (in)	110 -116 (4.33 -4.57)
Distance between the clutch pedal and the pedal stopper when the clutch pedal is released mm (in)	13.5 (0.53) or more

LUBRICANTS

M1211000400440

Item	Specified lubricant	Quantity
Clutch fluid	DOT 3 or DOT 4	As required
Release cylinder push rod	mitsubishi Part No.0101011 or equivalent	

ON-VEHICLE SERVICE

CLUTCH PEDAL CHECK

M1211000900746

NOTE: This clutch pedal assembly is unadjustable because of its structure.

1. Measure the clutch pedal looseness (A).

Standard value (A): 4 mm (0.16 inch) or less

2. If the clutch pedal looseness is not within the standard value, the clutch pedal assembly may have an abnormality. In this case, check the clutch pedal assembly, and replace if necessary.

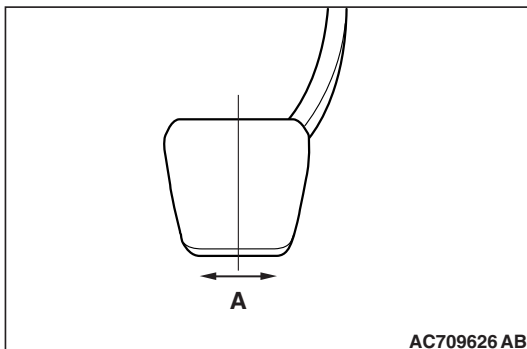

AC709626 AB

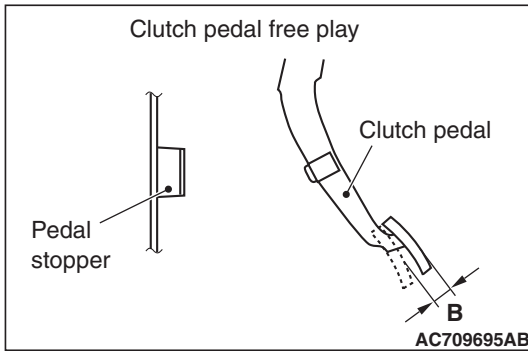

3. Check that the clutch pedal play (B) and height (C) as well as the clearance (D) between the clutch pedal and pedal stopper when the clutch is disengaged are within the standard value.

Standard value (B): 4 –9 mm (0.16 –0.35 inch)

Standard value (C): 110 –116 mm (4.33 –4.57 inch)

Standard value (D): 13.5 mm (0.53 inch) or more

4. If the clutch pedal play and height as well as the clearance between the clutch pedal and pedal stopper when the clutch is disengaged are not within the standard value, the air intrusion into the hydraulic system may have occurred, or either the clutch master cylinder or the clutch release cylinder may have an abnormality. In this case, perform air bleeding, or check the clutch master cylinder or the clutch release cylinder, and replace if necessary.

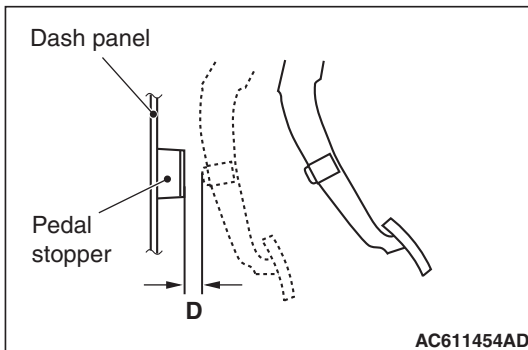
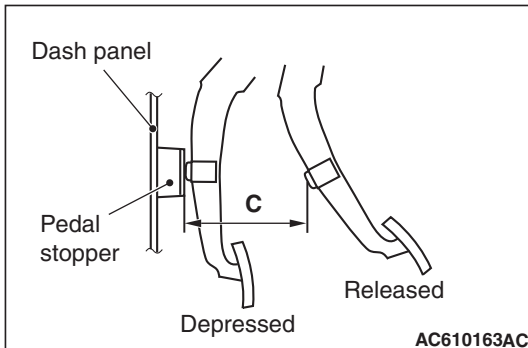

CLUTCH BLEEDING

M1211001400603

⚠ CAUTION

Use the clutch fluid of the specified brand name. Do not mix the fluid with other products.

Specified fluid: DOT 3 or DOT 4

1. Remove the air cleaner element, air cleaner intake duct, and air cleaner body. (Refer to GROUP 15, Air Cleaner P.15-11.)
2. Remove the cap. Then, connect the air bleeding hose to the air bleeding nipple.
3. Loosen the air bleeding nipple.
4. Perform the air bleeding by depressing the clutch pedal.
5. Remove the air bleeding hose. Tighten the air bleeding nipple to the specified torque. Then, install the cap.

Tightening torque: 11 ± 1 N·m (8 ± 1 ft-lb)

6. Check that the brake fluid level is between "MAX" and "MIN" of the brake fluid reservoir.

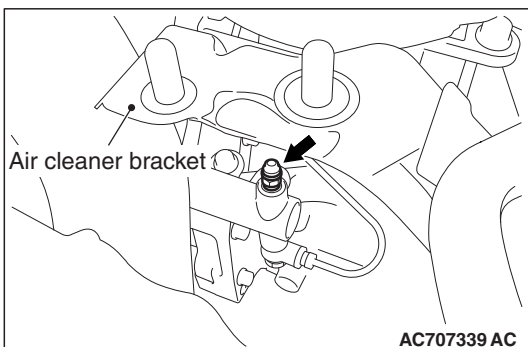

CLUTCH PEDAL AND MASTER CYLINDER

REMOVAL AND INSTALLATION

M1211005200076

⚠ CAUTION

Do not apply grease or lubricant to the switch and the switch installation section to avoid malfunction of the switch. In addition, do not perform work wearing gloves which have grease on them.

Pre-removal Operation

- Instrument Panel Cover Lower Removal <MR> (Refer to GROUP 52A, Instrument Lower Panel [P.52A-3](#)).
- Knee Air Bag Module Removal (Refer to GROUP 52B, Knee Air Bag Module [P.52B-425](#)).
- ETACS-ECU Removal (Refer to GROUP 54A, [P.54A-742](#)).
- Engine Control Harness Connector Bracket Removal (Refer to GROUP 54A, Battery [P.54A-10](#).)
- Air Cleaner Assembly Removal (Refer to GROUP 15, Air Cleaner [P.15-11](#)).

Post-installation Operation

- Air Cleaner Assembly Installation (Refer to GROUP 15, Air Cleaner [P.15-11](#)).
- Engine Control Harness Connector Bracket Installation (Refer to GROUP 54A, Battery [P.54A-10](#).)
- ETACS-ECU Installation (Refer to GROUP 54A, [P.54A-742](#)).
- Knee Air Bag Module Installation (Refer to GROUP 52B, Knee Air Bag Module [P.52B-425](#)).
- Instrument Panel Cover Lower Installation <MR> (Refer to GROUP 52A, Instrument Lower Panel [P.52A-3](#)).
- Clutch Fluid Refilling (Refer to [P.21A-3](#)).
- Clutch Line Bleeding (Refer to [P.21A-3](#)).
- Clutch Pedal Check (Refer to [P.21A-2](#)).

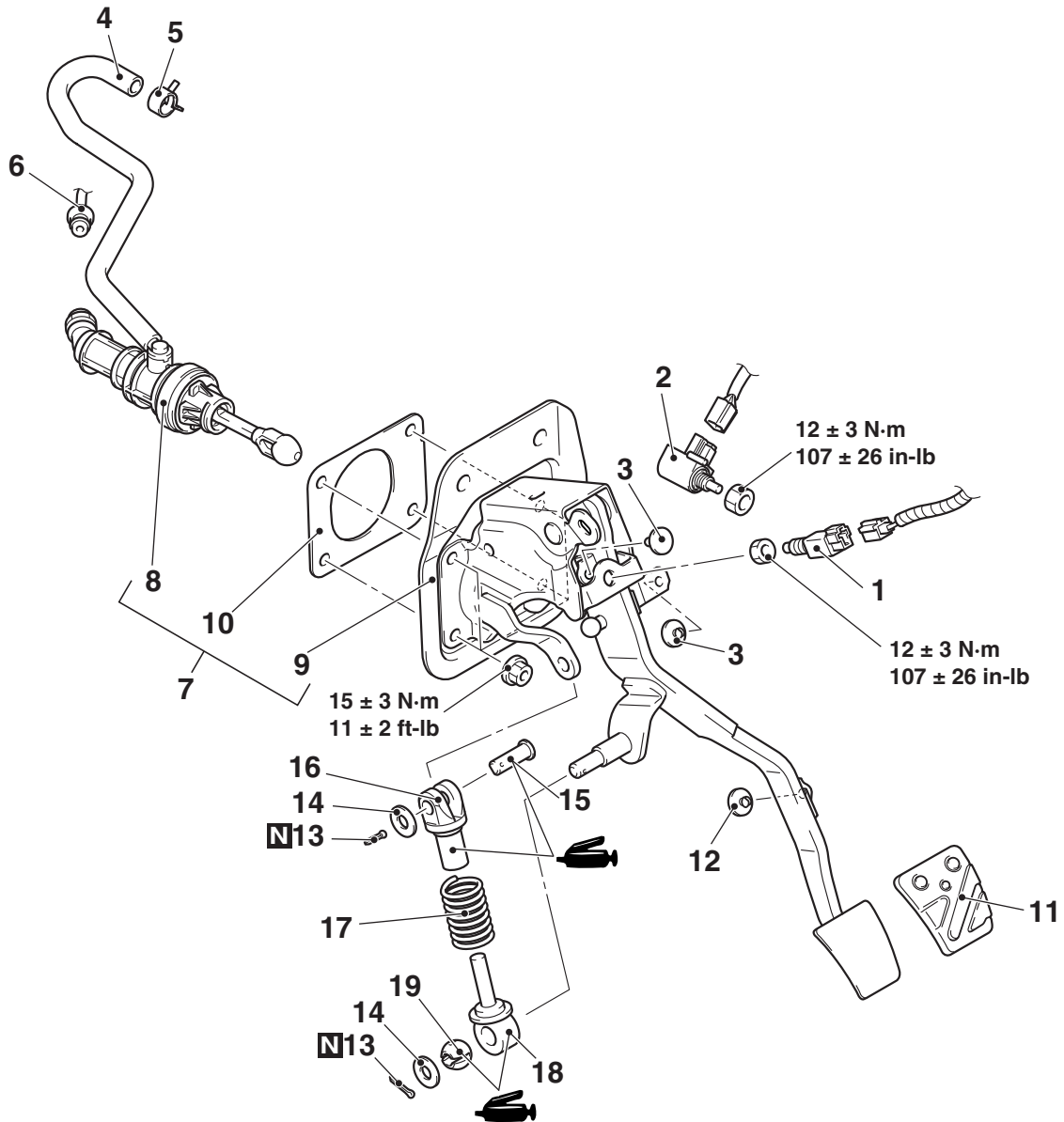

AC709620AB

- | | | Removal steps | |
|-------|-------|---|-----------------------------------|
| >>C<< | 1. | Clutch switch | |
| >>B<< | 2. | Clutch interlock switch | |
| | 3. | Stopper | |
| | 4. | Reservoir hose and brake fluid reservoir connection | |
| | 5. | Hose clip | |
| <<A>> | >>A<< | 6. | Clutch tube assembly A connection |
| | 7. | Clutch master cylinder and clutch pedal assembly | |
| <> | 8. | Clutch master cylinder | |

- | Removal steps | |
|----------------------|-----------------------|
| 9. | Clutch pedal assembly |
| 10. | Sealer |
| 11. | Pedal pad |
| 12. | Stopper |
| 13. | Sprit pin |
| 14. | Washer |
| 15. | Clevis pin |
| 16. | Rod A |
| 17. | Turn over spring |
| 18. | Rod B |
| 19. | Bush |

REMOVAL SERVICE POINTS

<<A>> CLUTCH TUBE ASSEMBLY A DISCONNECTION

⚠ CAUTION

- Do not remove O-rings and clips from the clutch tube assembly A and clutch master cylinder.
- If the O-ring or clip is damaged, replace the relevant clutch tube assembly A or clutch master cylinder.

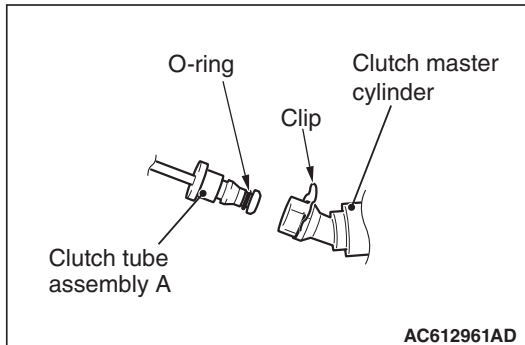

<> CLUTCH MASTER CYLINDER REMOVAL

Pull out the clutch master cylinder while rotating it 45° to the direction of the arrow shown in the figure.

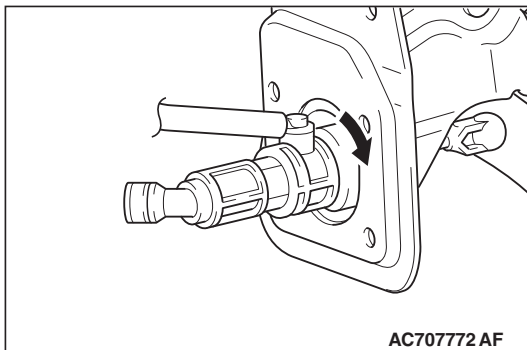

INSTALLATION SERVICE POINTS

>>A<< CLUTCH TUBE ASSEMBLY A CONNECTION

⚠ CAUTION

- When connecting the clutch tube assembly A and clutch master cylinder, check that the O-ring and clip are not damaged.
- If any connection areas of clutch tube assembly A and clutch master cylinder or O-ring is dirty, clean with the clutch fluid.

Assemble the clip to the clutch master cylinder. Then, connect the clutch tube assembly A to the clutch master cylinder.

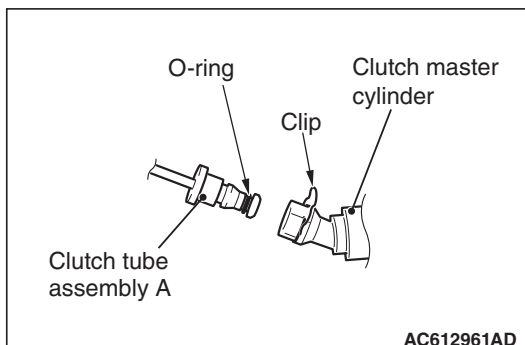

>>B<< CLUTCH INTERLOCK SWITCH INSTALLATION

Install the clutch interlock switch according to the dimension shown in the figure.

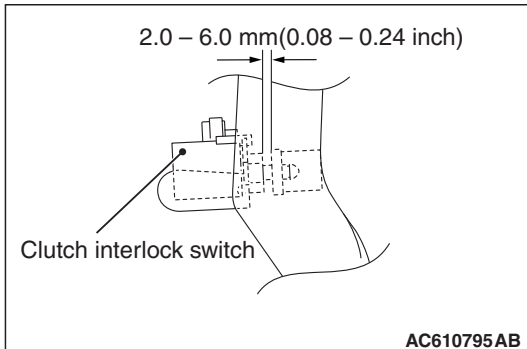

>>C<< CLUTCH SWITCH INSTALLATION

Install the clutch switch according to the dimension shown in the figure.

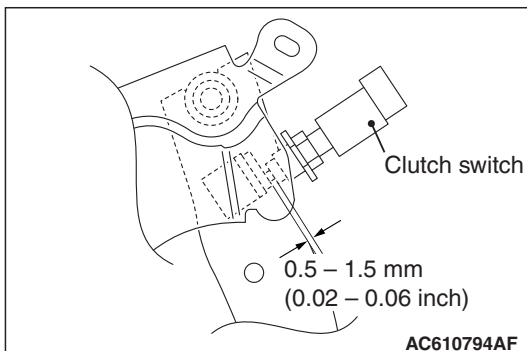

INSPECTION

CLUTCH SWITCH CHECK AND ADJUSTMENT

M1211001100464

⚠ CAUTION

Do not apply grease or lubricant to the switch and the switch installation section to avoid malfunction of the switch. In addition, do not perform work wearing gloves which have grease on them.

1. Connect a circuit tester (Ω range) to the clutch switch connector.
2. When continuity does not exist with the plunger pressed from the outer case end face by the dimension shown in the figure, and when continuity exists with the plunger released (2Ω or less), the switch is in good condition.

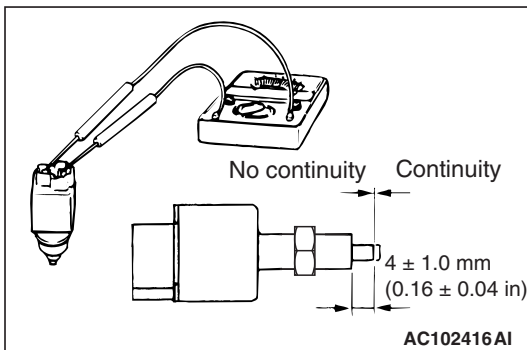

INTERLOCK SWITCH OPERATING CHECK

M1211001000199

⚠ CAUTION

Do not apply grease or lubricant to the switch and the switch installation section to avoid malfunction of the switch. In addition, do not perform work wearing gloves which have grease on them.

1. Connect a circuit tester (Ω range) to the clutch interlock switch connector.
2. If continuity exists (2Ω or less) when the shaft is pressed to the value shown in the figure or more, and continuity does not exist when the shaft is released, the clutch interlock switch is in good condition.

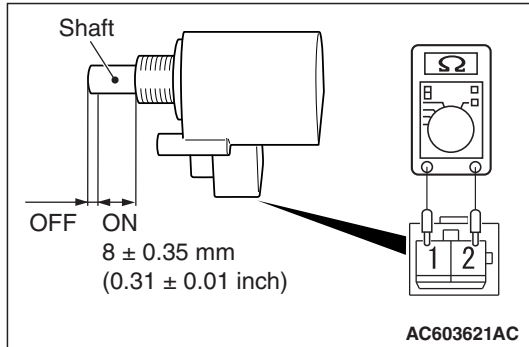

CLUTCH CONTROL

REMOVAL AND INSTALLATION

M1211001901225

Pre-removal Operation

- Strut Tower Bar Removal (Refer to GROUP 42A, Strut Tower Bar P.42A-14).
- Air Cleaner Assembly Removal (Refer to GROUP 15, Air Cleaner P.15-11).
- Engine Control Harness Connector Bracket Removal (Refer to GROUP 54A, Battery P.54A-10.)
- Clutch Fluid Draining

Post-installation Operation

- Engine Control Harness Connector Bracket Installation (Refer to GROUP 54A, Battery P.54A-10.)
- Air Cleaner Assembly Installation (Refer to GROUP 15, Air Cleaner P.15-11).
- Strut Tower Bar Installation (Refer to GROUP 42A, Strut Tower Bar P.42A-14).
- Clutch Fluid Supplying
- Clutch Line Bleeding (Refer to P.21A-3).
- Clutch Pedal Check (Refer to P.21A-2).

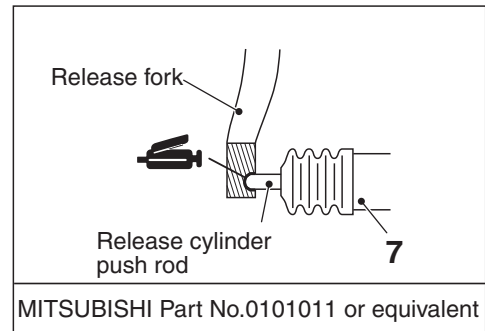
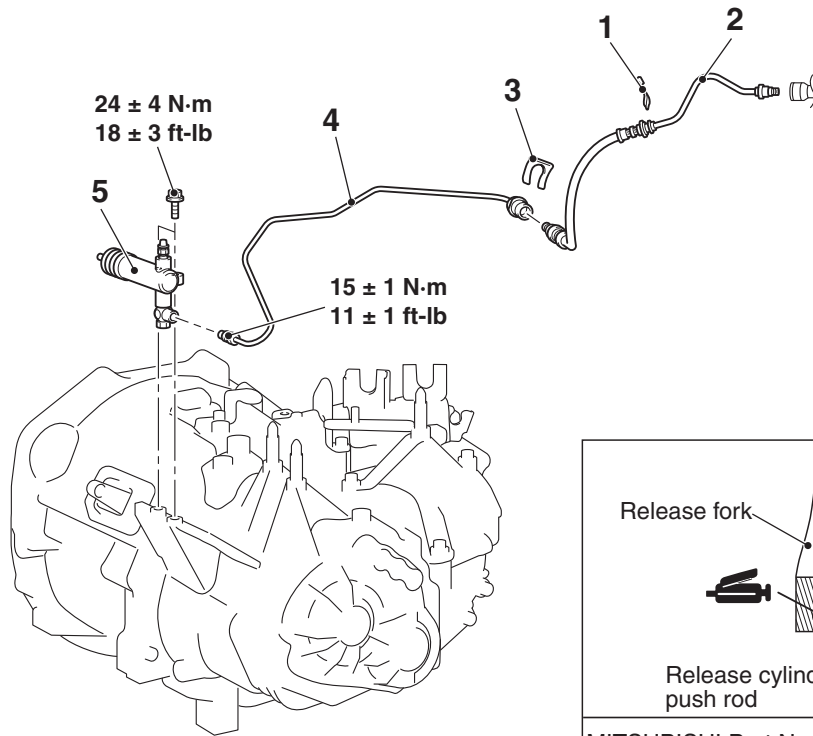

AC709624AD

Clutch line removal steps

- Air cleaner assembly (Refer to GROUP 15, Air Cleaner P.15-11.)
1. Hose clip B
 2. Clutch tube assembly A
 3. Hose clip A
 4. Clutch tube assembly B

<<A>> >>A<<

<<A>> >>A<<

Clutch release cylinder removal steps

- Air cleaner element, air cleaner intake duct, air cleaner body, air cleaner bracket (Refer to GROUP 15, Air Cleaner P.15-11.)
5. Clutch release cylinder

REMOVAL SERVICE POINTS

<<A>> CLUTCH TUBE ASSEMBLY DISCONNECTION

⚠ CAUTION

- Do not remove O-rings and clips from the clutch tube assembly and clutch master cylinder.
- When the O-ring or clip is damaged, always replace the relevant clutch tube assembly or clutch master cylinder.

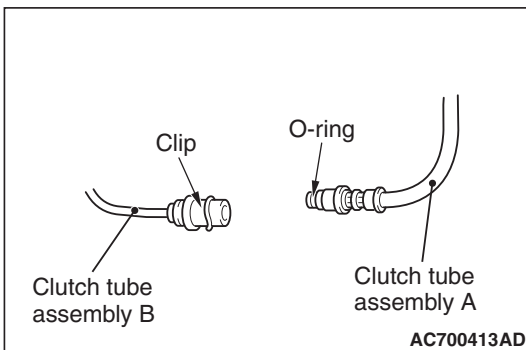
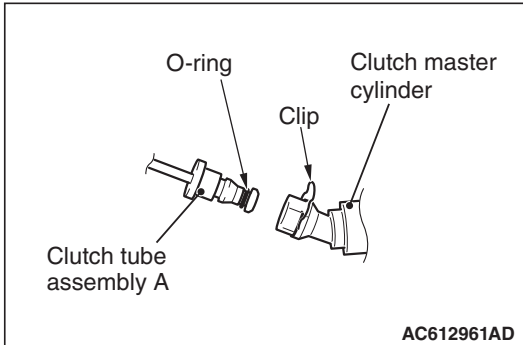

INSTALLATION SERVICE POINTS

>>A<< CLUTCH TUBE ASSEMBLY INSTALLATION

⚠ CAUTION

- When connecting each part, check that the O-ring and clip are not damaged.
- If any connection area or O-ring is dirty, clean with the clutch fluid.

Assemble the clips to the clutch master cylinder and clutch tube assembly B. Then, connect the clutch tube assembly A.

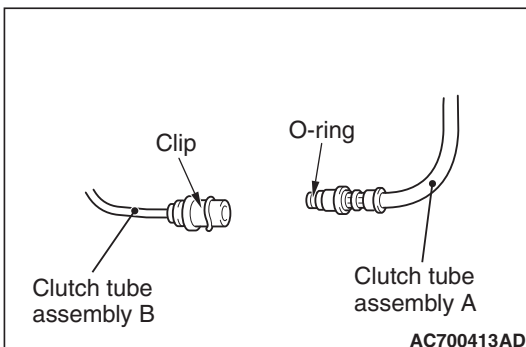
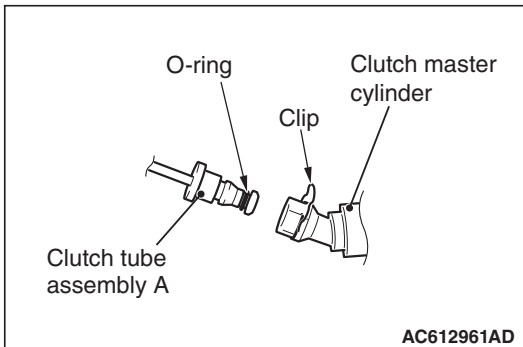

INSPECTION

- Check the master cylinder or clutch hose for fluid leakage.
- Check the clutch hose or tube for cracks or clogging.