

GROUP 70

**COMPONENT
LOCATIONS**

CONTENTS

RELAY	70-2	FUSIBLE LINK, FUSE AND IOD OR STORAGE CONNECTOR.....	70-13
OTHER DEVICES	70-3	SOLENOID AND SOLENOID VALVE.....	70-14
CONTROL UNIT.....	70-4	GROUNDING CABLE.....	70-16
INSPECTION TERMINAL	70-7	GROUNDING	70-17
SENSOR.....	70-8		

RELAY

Name	Symbol	Name	Symbol
A/C compressor clutch relay	A	Heated seat relay	B
Blower relay	B	Horn relay	A
Condenser fan relay	A	Injector relay	A
Daytime running light relay	A	MFI relay	A
Electric pump relay	A	Radiator fan relay	A
Fan control relay	A	Rear window defogger relay	B
Fog light relay	A	Starter relay	A
Fuel pump relay 1	A	Theft-alarm horn relay	A
Headlight relay (High)	A	Throttle actuator control motor relay	A
Headlight relay (Low)	A		

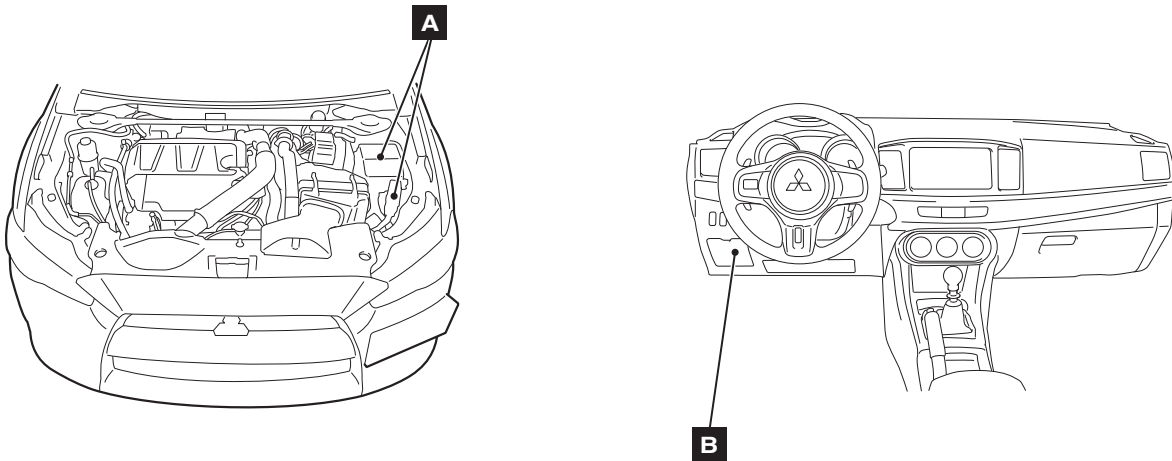

AC708720AB

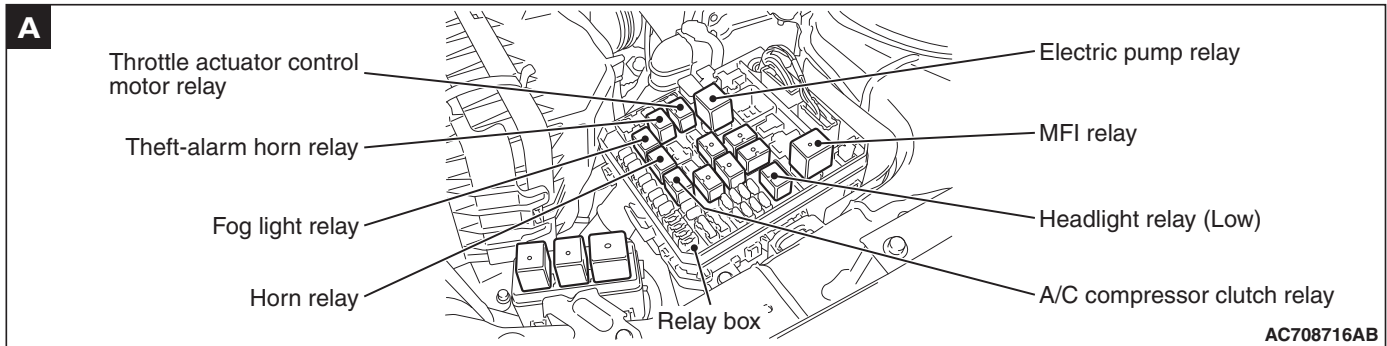

AC708716AB

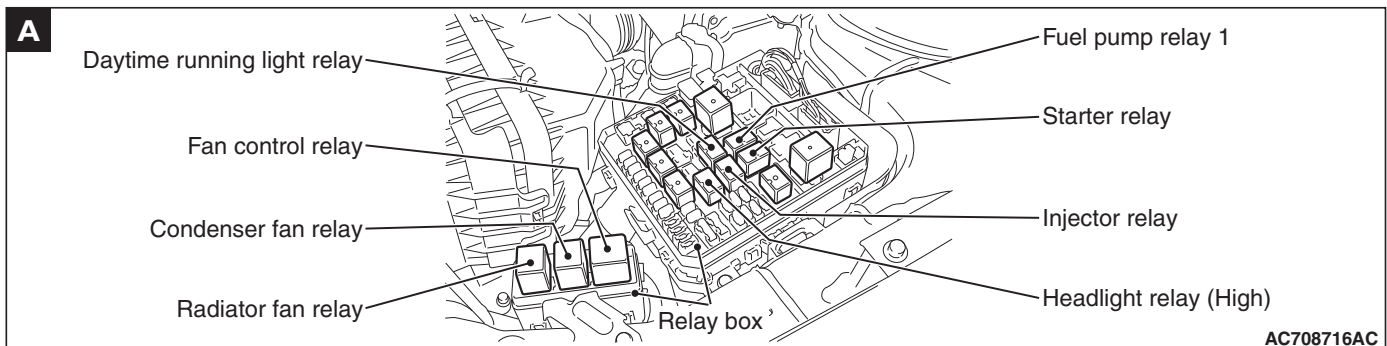

AC708716AC

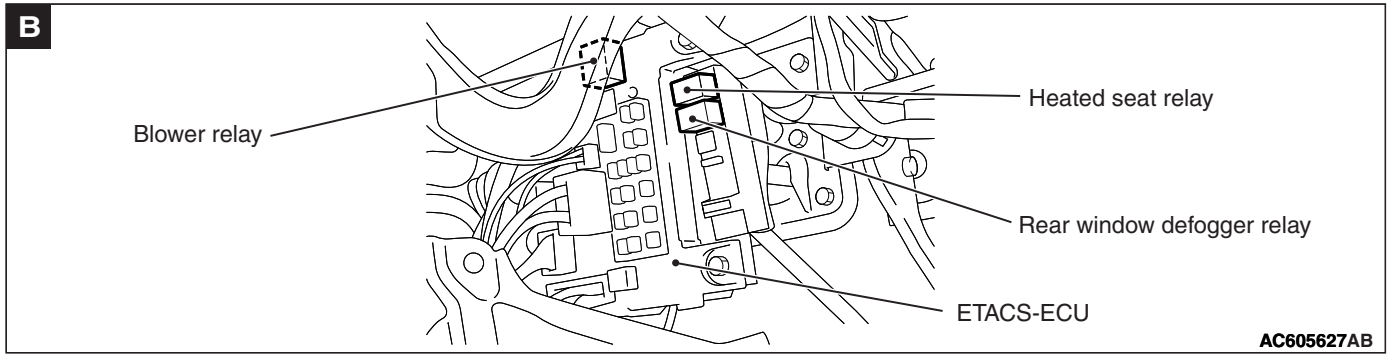

OTHER DEVICES

M1701005600517

Name	Symbol	Name	Symbol
A/C compressor clutch assembly (incorporating A/C refrigerant temperature switch)	B	Power steering pressure switch	A

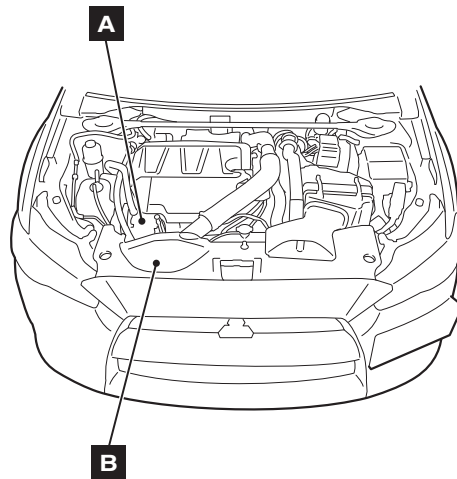

AC708727AB

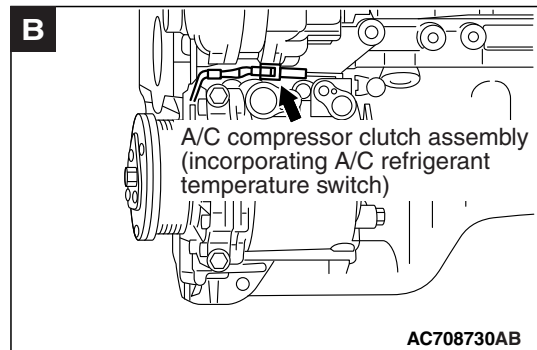
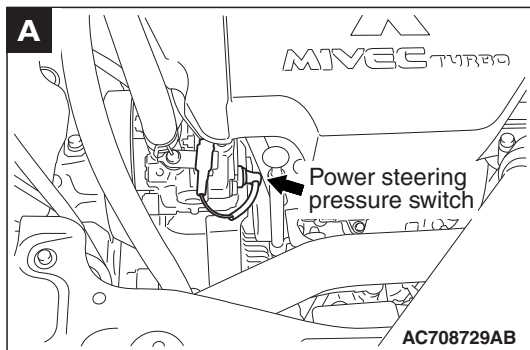

CONTROL UNIT

M1701000700984

Name	Symbol	Name	Symbol
A/C-ECU <Vehicles with air conditioning system>	O	Heater control module <Vehicles without air conditioning system>	O
ASC-ECU	A	KOS-ECU	L
AWC-ECU	J	Multivision display <Vehicles with MMCS>	H
CAN box unit <Vehicles with MMCS>	H	Power window main switch (incorporating CPU)	R
Column switch (incorporating column-ECU)	E	Receiver antenna assembly	S
Combination meter (incorporating CPU)	F	Receiver antenna module <Vehicles with KOS>	G
Headlight control unit <Vehicles with discharge headlight>	D	Shift lever (incorporating CPU) <TC-SST>	N
Engine control module	B	SRS-ECU	M
ETACS-ECU	K	Sunroof motor assembly (incorporating CPU)	Q
Front seat assembly (RH) (incorporating occupant classification-ECU)	P	Transaxle assembly (incorporating ECU) <TC-SST>	C
Hands free module	I	Wireless control module <Vehicles without KOS>	G

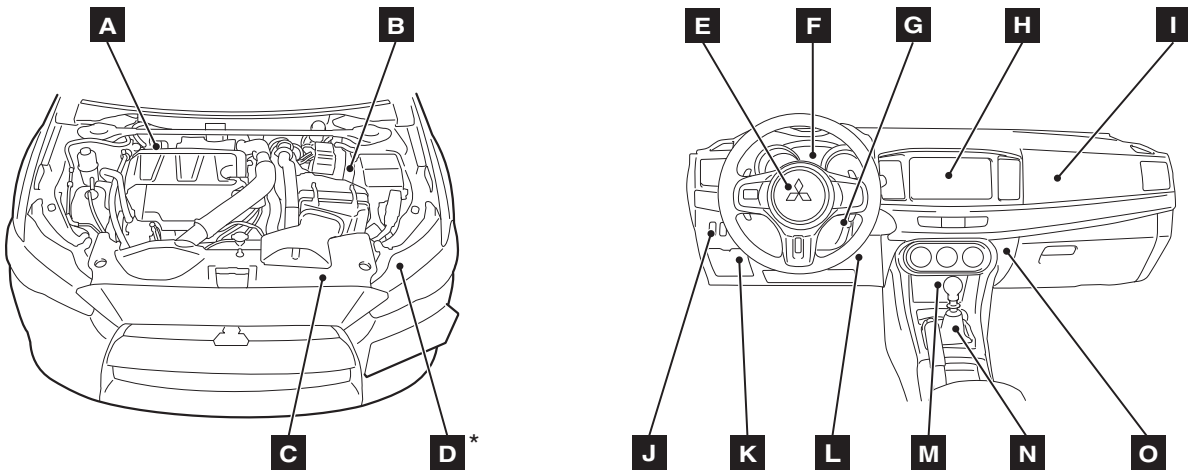

AC708720AC

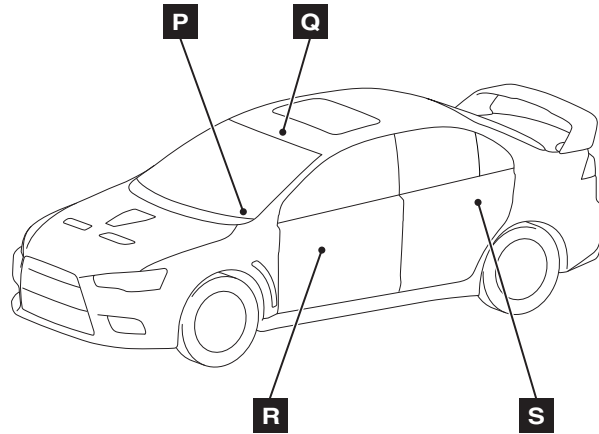

AC705160AE

NOTE: The * symbols indicate equipped at both side.

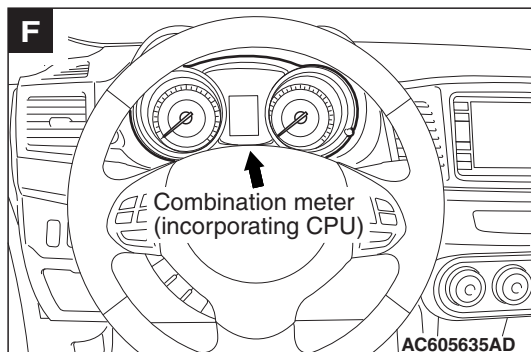
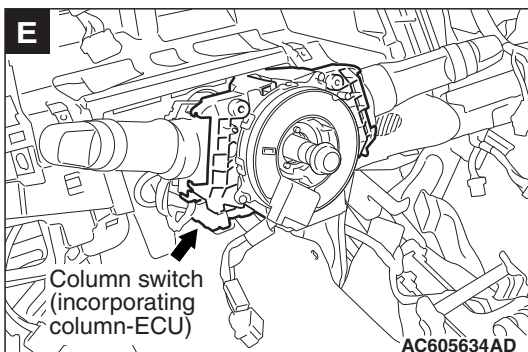
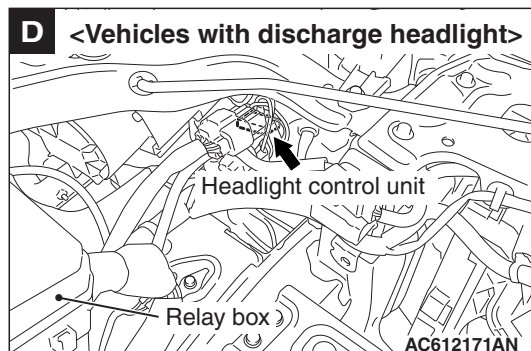
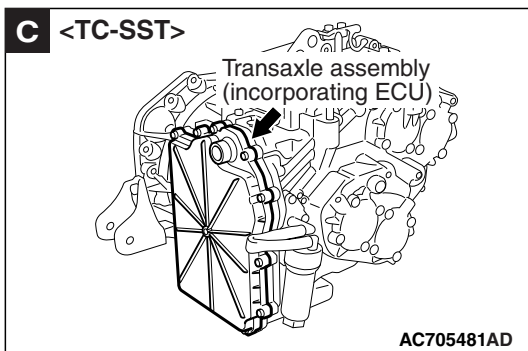
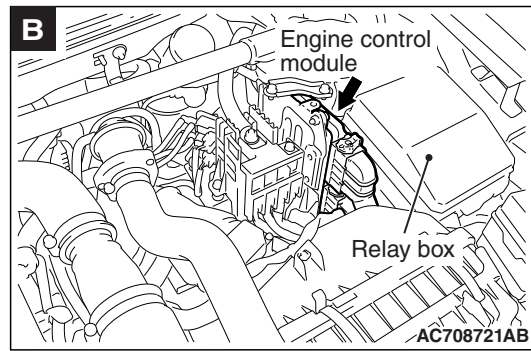
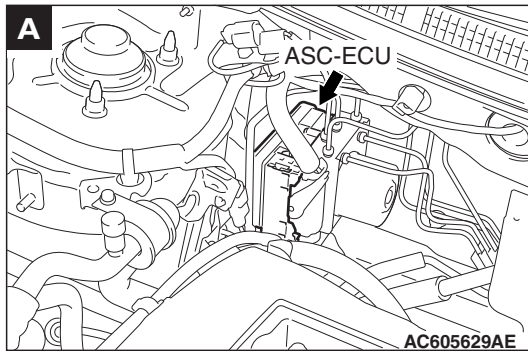

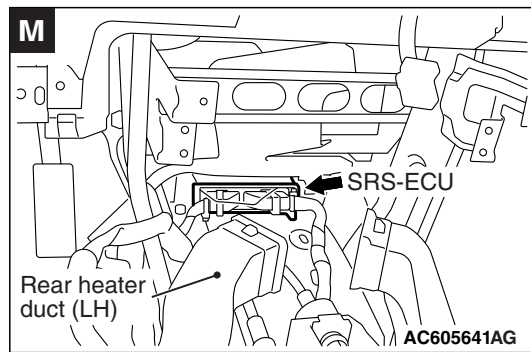
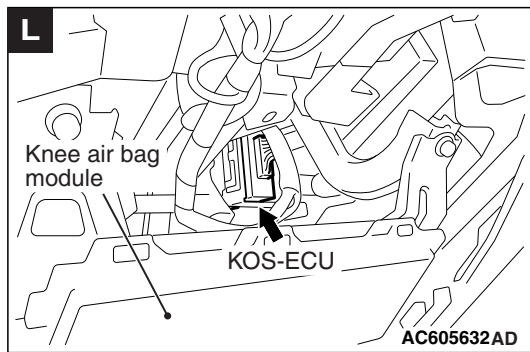
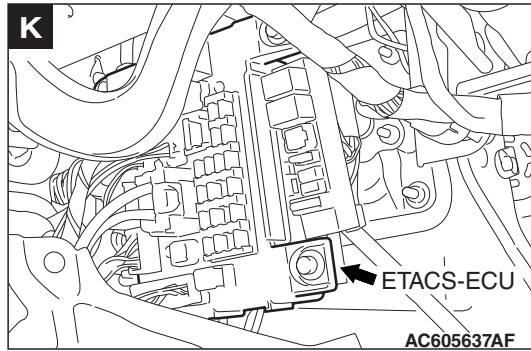
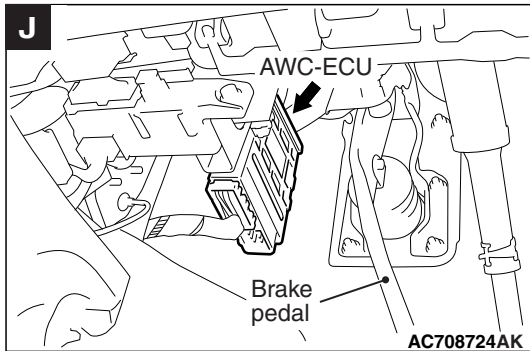
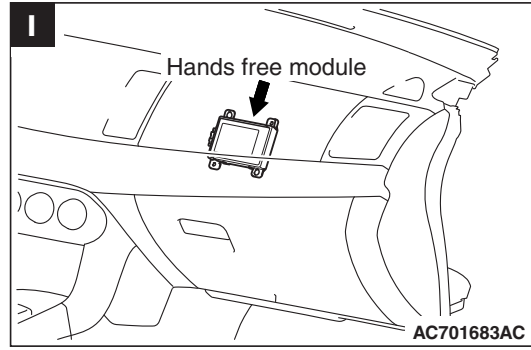
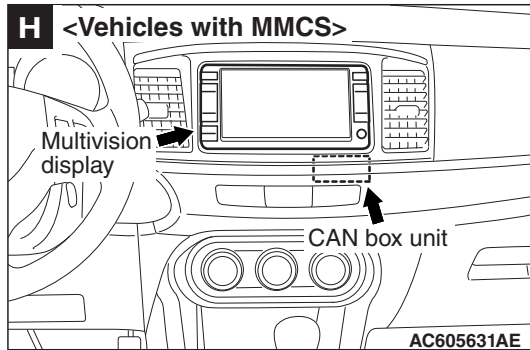
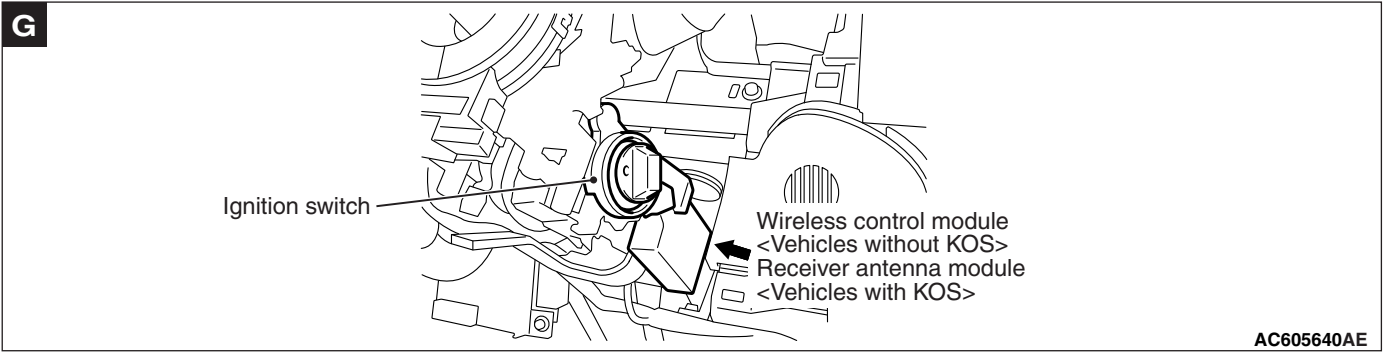

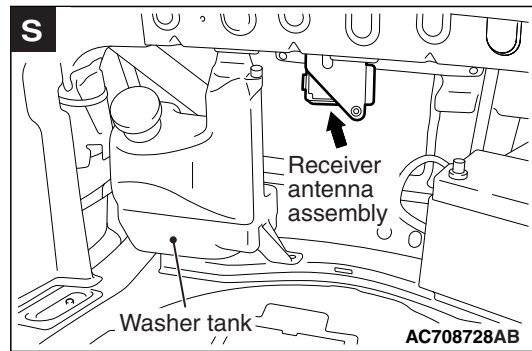
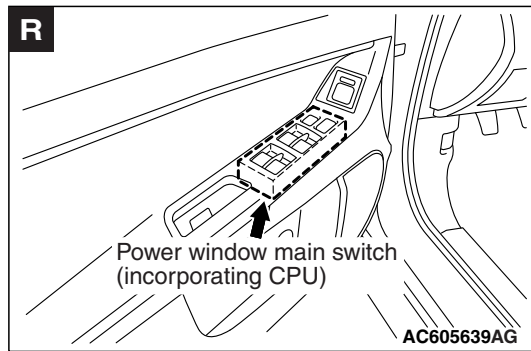
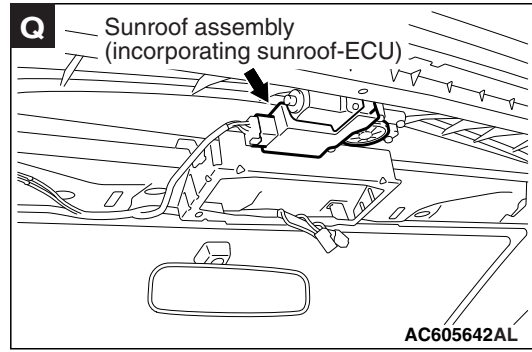
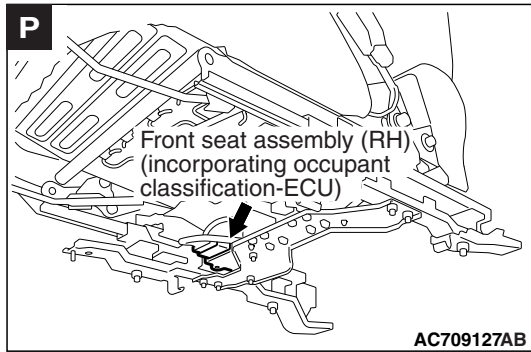
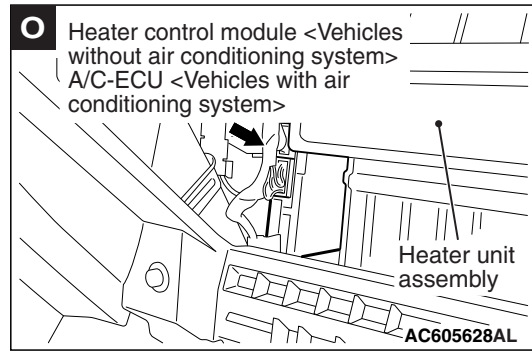
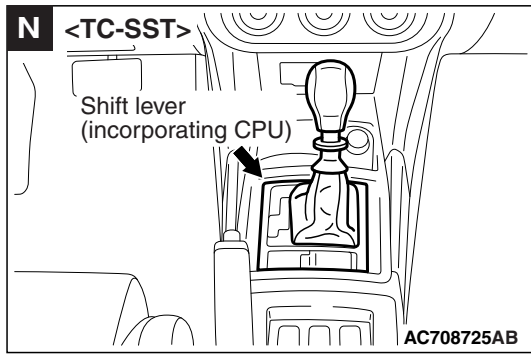

INSPECTION TERMINAL

M1701000200990

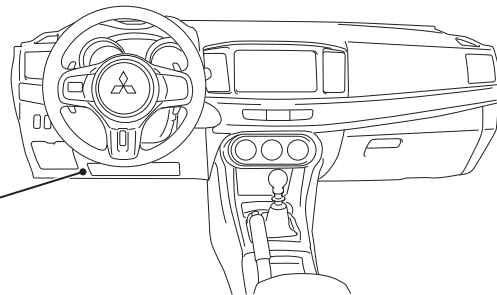
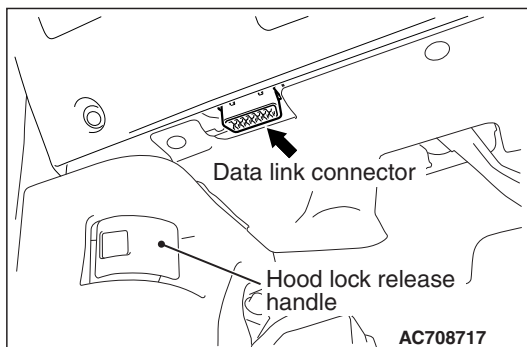

AC708718AB

SENSOR

M1701000602143

Name	Symbol	Name	Symbol
A/C pressure sensor	F	Intake air temperature sensor 2	B
Accelerator pedal position sensor	M	Intake camshaft position sensor	B
Ambient air temperature sensor	H	Interior temperature sensor	L
Crankshaft position sensor	I	Knock sensor	G
Engine coolant temperature sensor	D	Lighting control sensor <Vehicles with automatic light>	R
Exhaust camshaft position sensor	C	Manifold absolute pressure sensor	A
Fin thermo sensor	P	Mass airflow sensor	E
Front impact sensor	J	Pressure sensor	U
Front passenger's seat (incorporating weight sensor)	Q	Rear wheel speed sensor	a
Front wheel speed sensor	V	Seat slide sensor	X
Fuel level sensor (sub)	T	Shift lever (incorporating lever position sensor) <TC-SST>	O
Fuel pump module (incorporating fuel level sensor (main) and fuel tank temperature sensor)	Z	Side impact sensor	Y
Fuel tank differential pressure sensor	Z	Steering wheel sensor	K
G and yaw rate sensor	N	Unlock sensor <Vehicles with KOS>	S
Heated oxygen sensor (Front)	W	Throttle body assembly (incorporating throttle position sensor)	B
Heated oxygen sensor (Rear)	W		

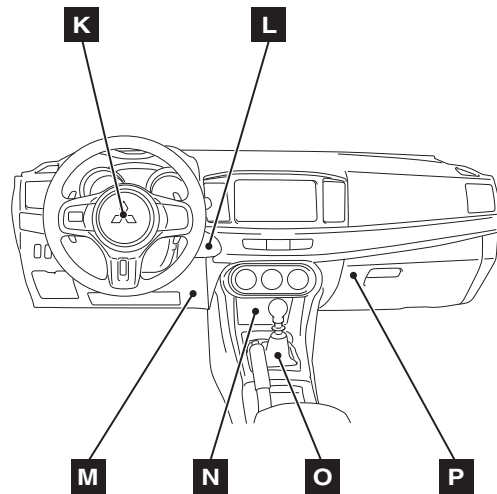
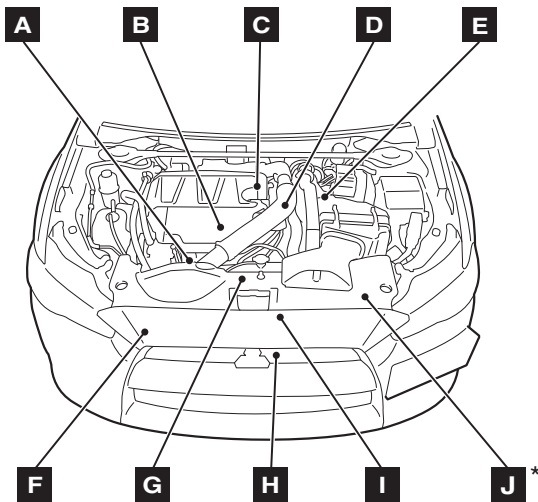

AC708720AD

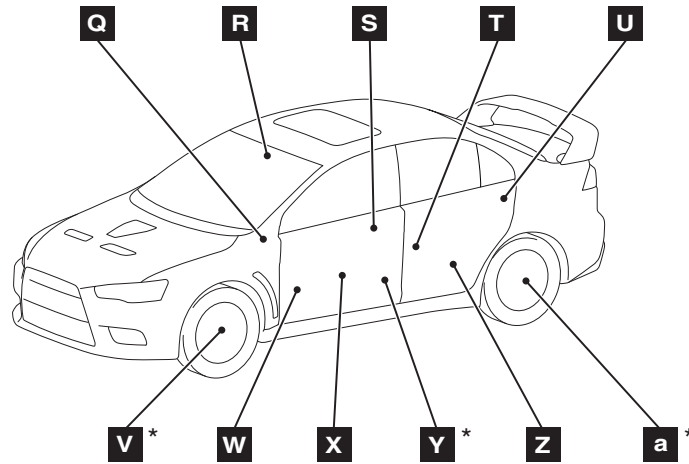

AC705160AF

NOTE: The * symbols indicate equipped at both sides.

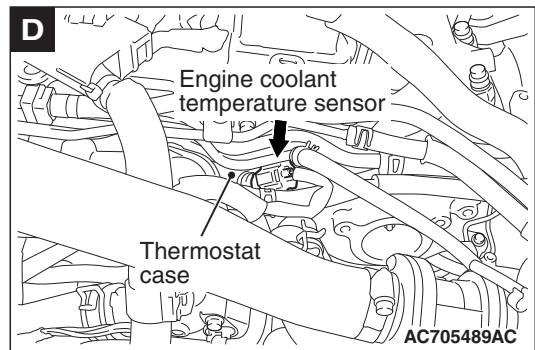
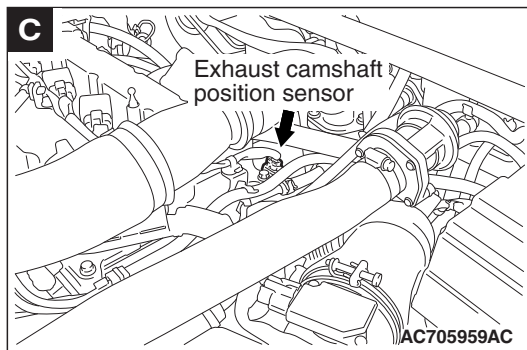
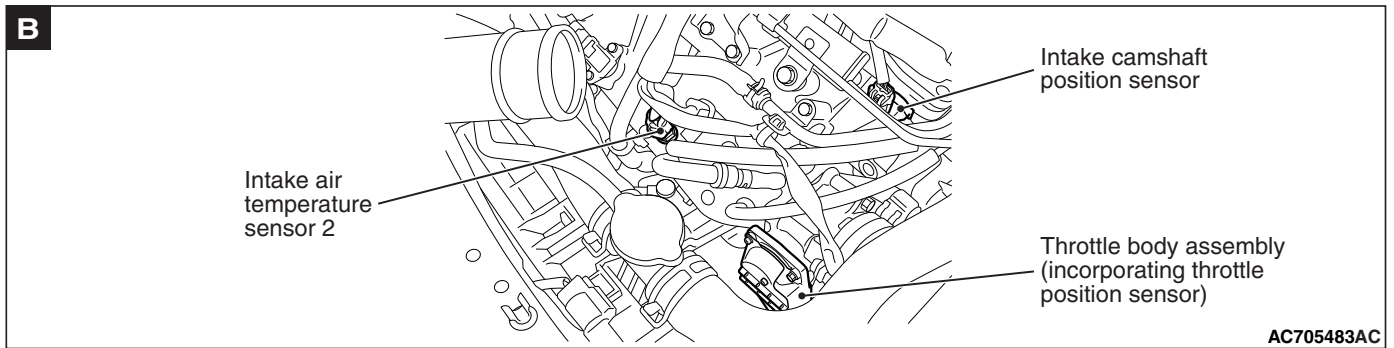
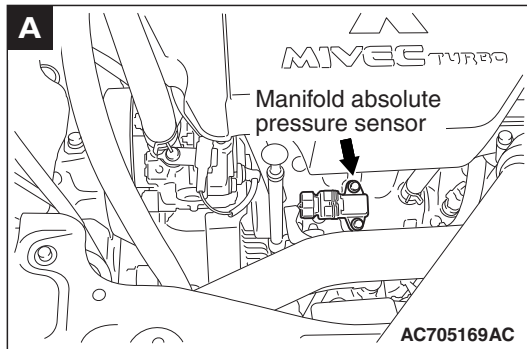

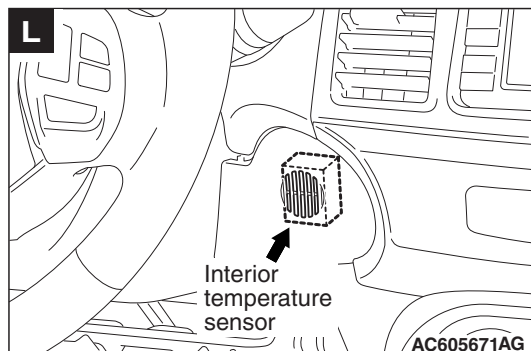
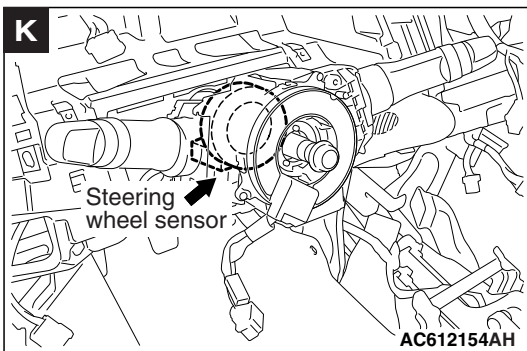
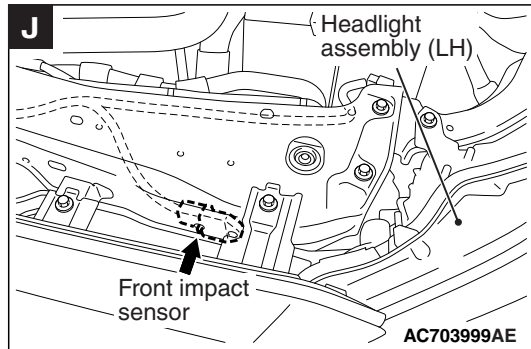
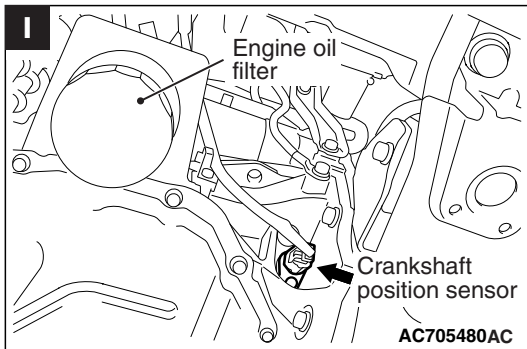
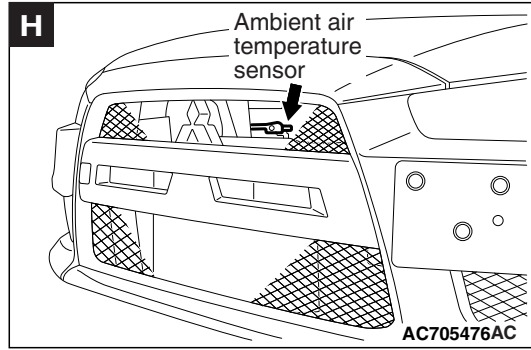
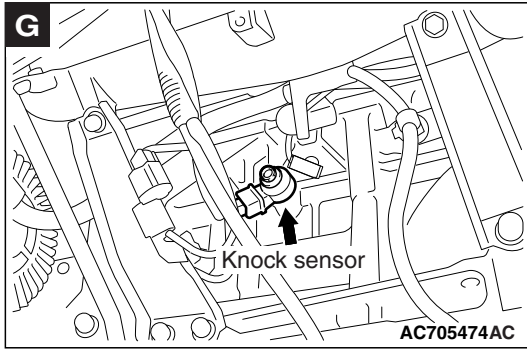
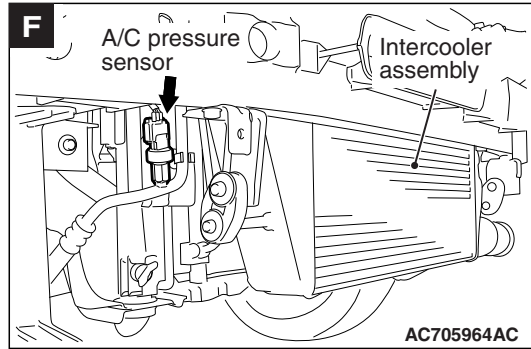
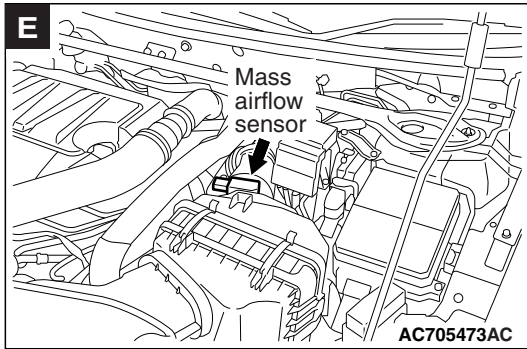

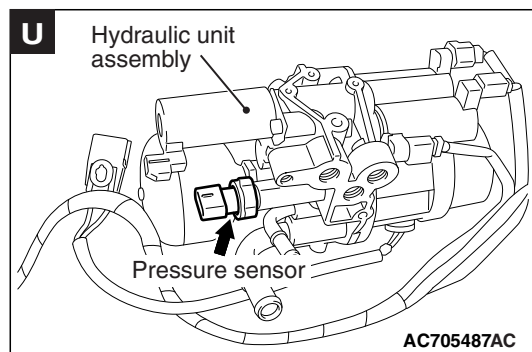
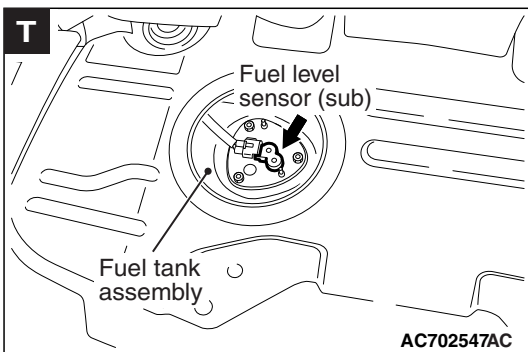
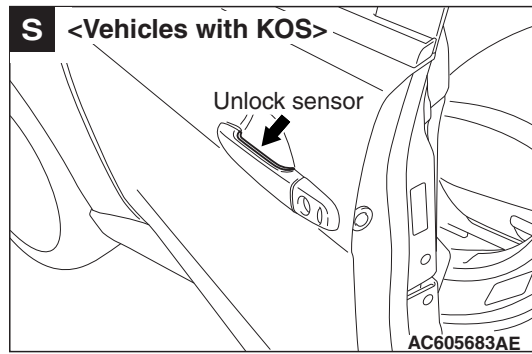
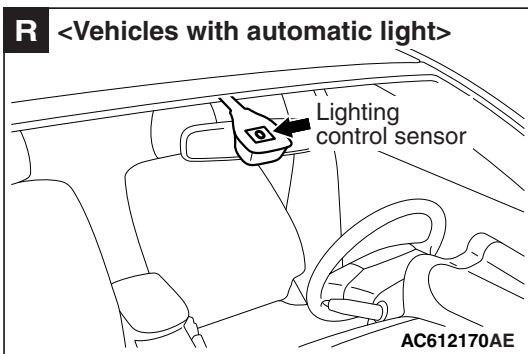
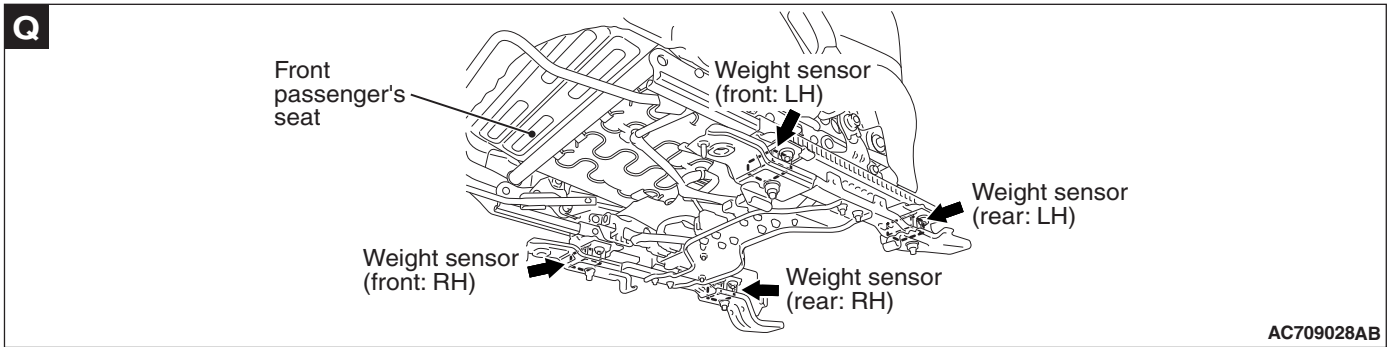
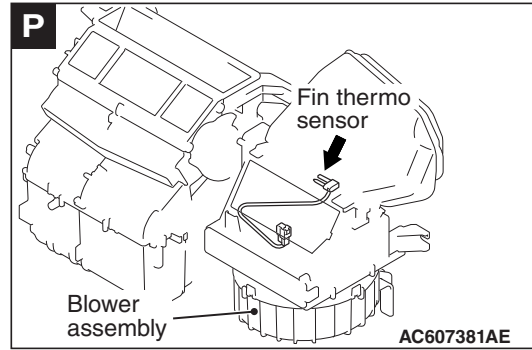
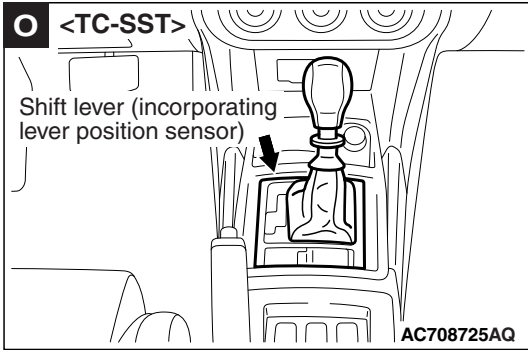
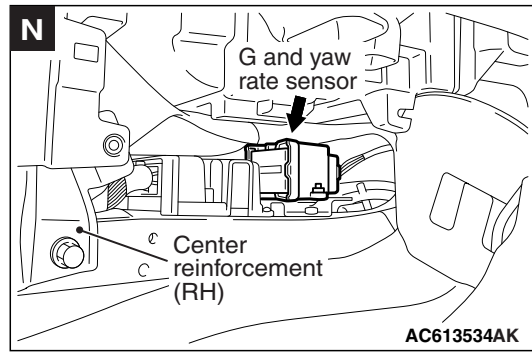
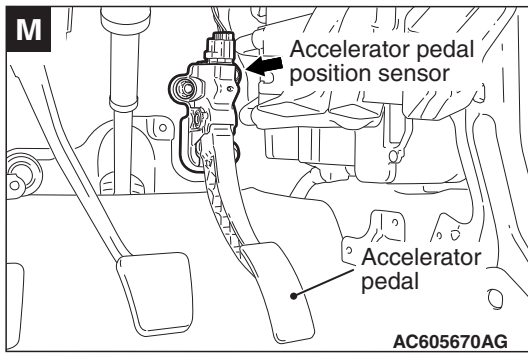

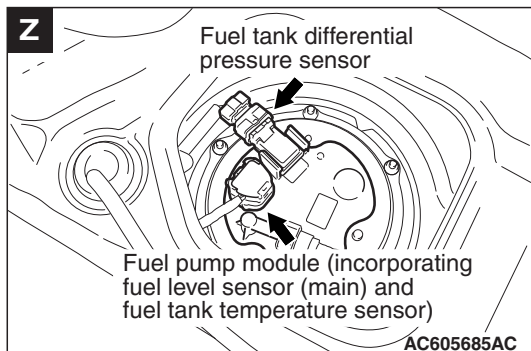
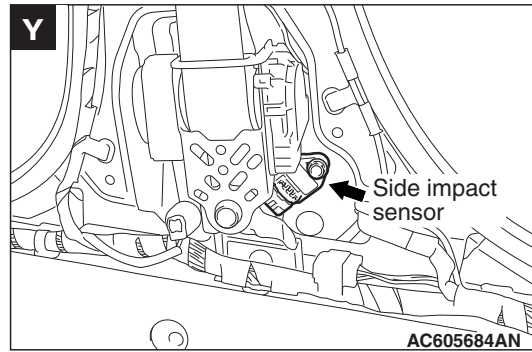
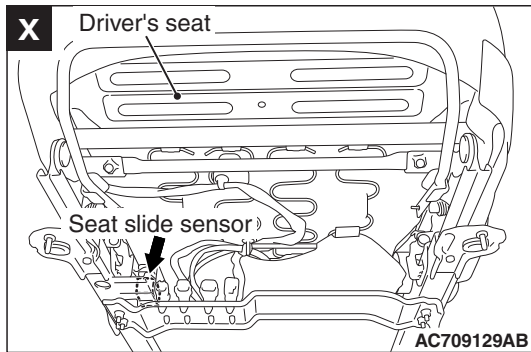
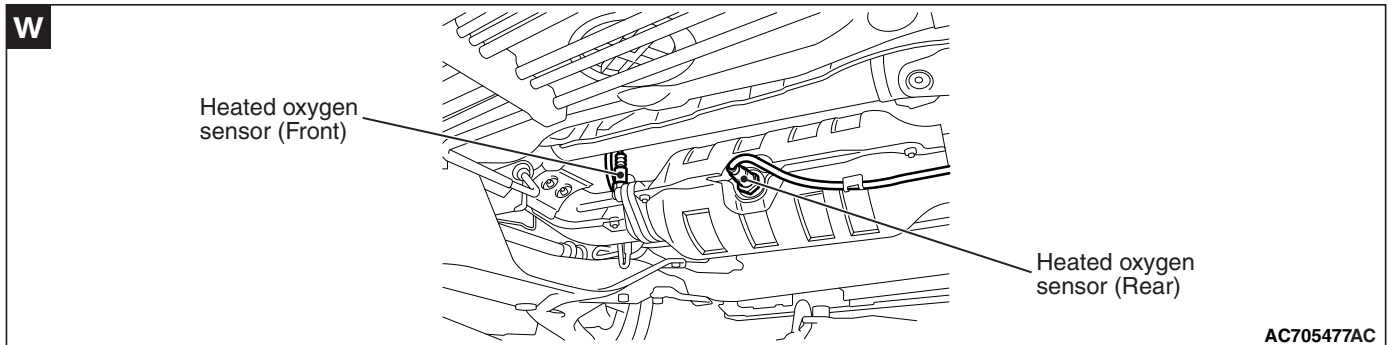
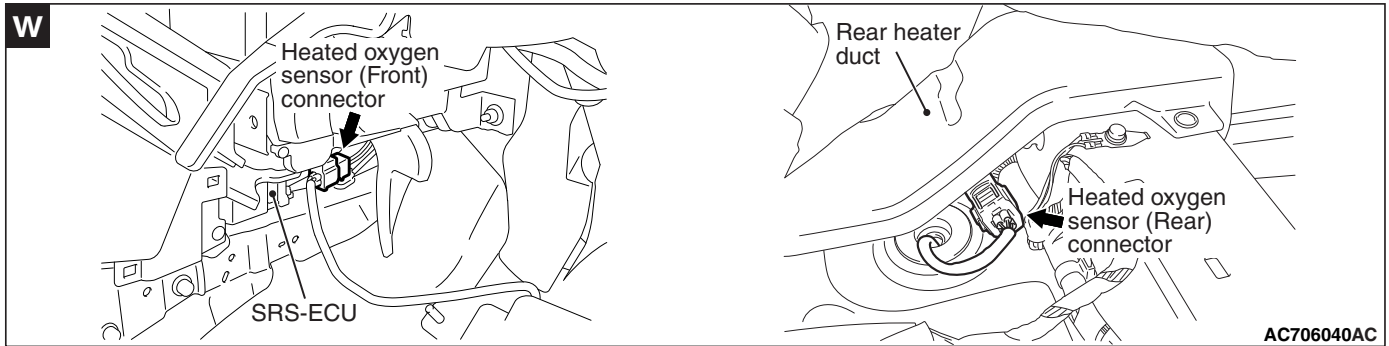
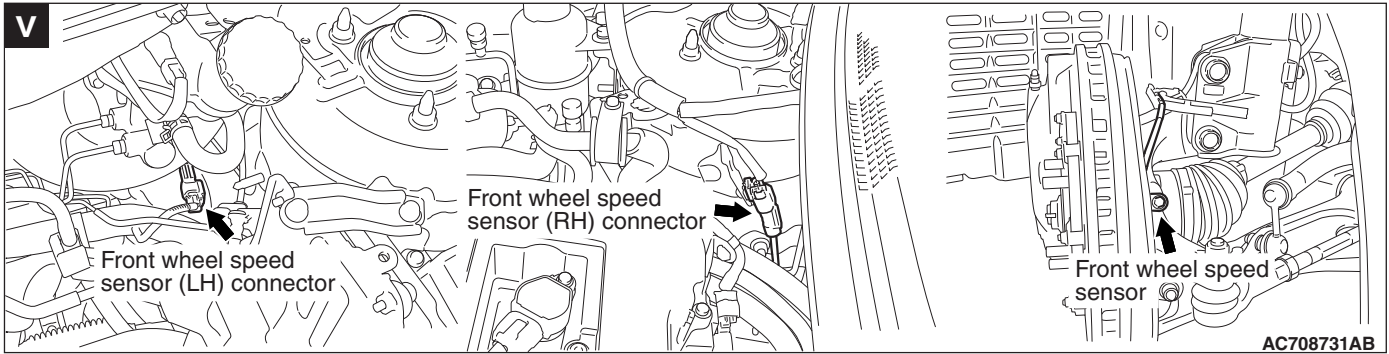

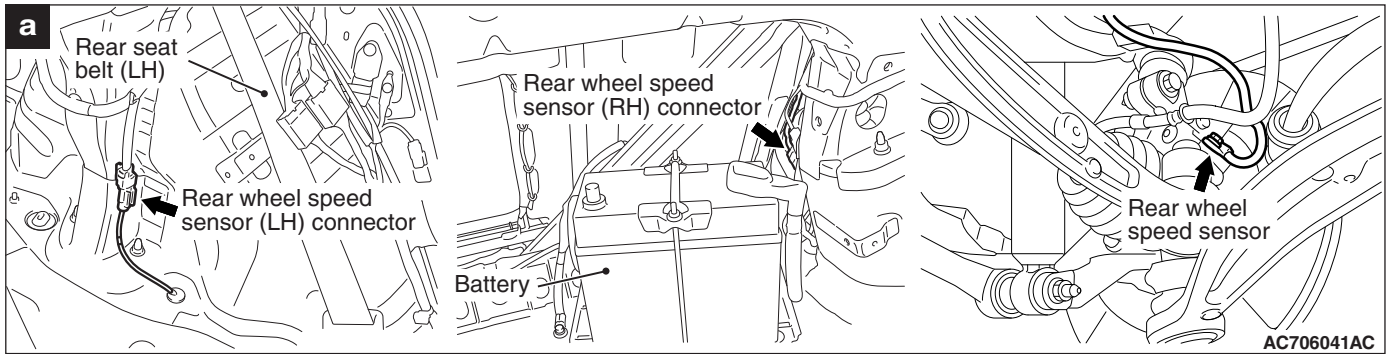

FUSIBLE LINK, FUSE AND IOD OR STORAGE CONNECTOR

M1701000101189

Name	Symbol	Name	Symbol
Fuse Nos.1 to 23 and 30 to 32 (Relay box in engine compartment)	B	Fusible link Nos.24 to 29 (Relay box in engine compartment)	B
Fuse Nos.2 to 19 and 22 to 25 (Passenger compartment)	C	Fusible link Nos.33 to 37 (Engine compartment)	A
Fusible link Nos.1, 20 and 21 (Passenger compartment)	C	IOD or storage connector	B

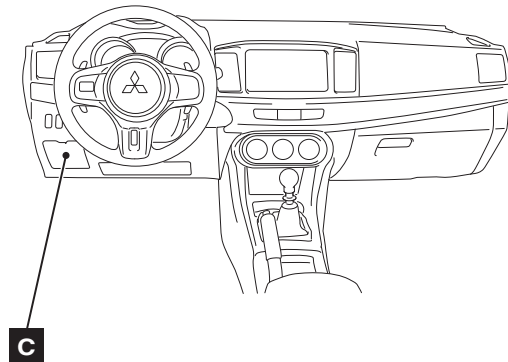
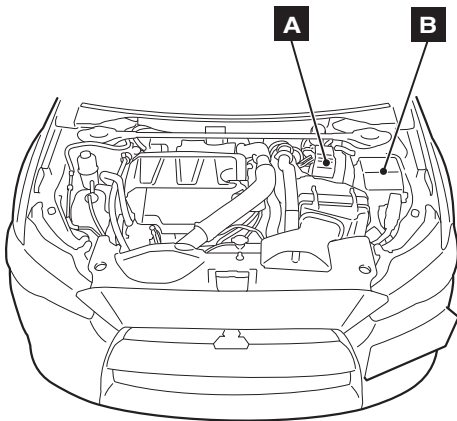

AC708720AF

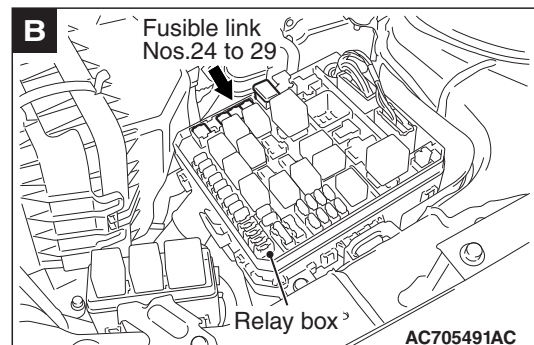
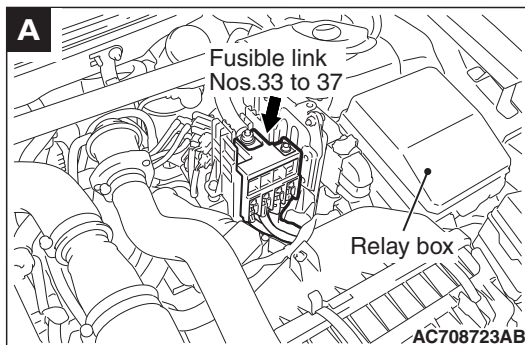

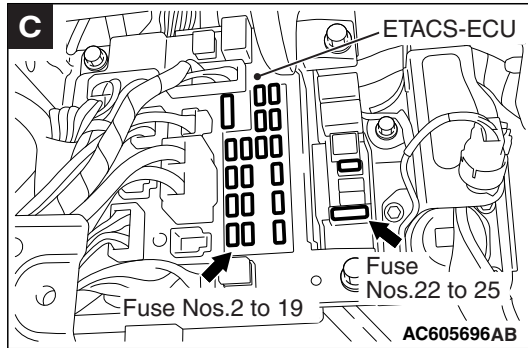
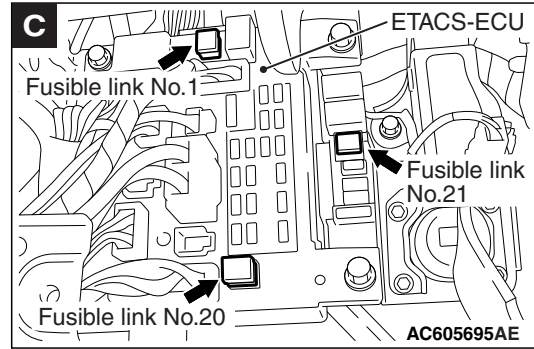
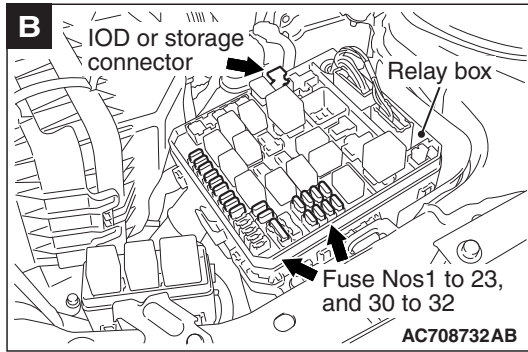

SOLENOID AND SOLENOID VALVE

M1701000801360

Name	Symbol	Name	Symbol
Evaporative emission purge solenoid	E	Intake oil feeder control valve	D
Evaporative emission ventilation solenoid	I	Shift lever (incorporating shift lock solenoid valve) <TC-SST>	G
Exhaust oil feeder control valve	A	Transaxle assembly (incorporating solenoid valve) <TC-SST>	F
Hydraulic unit (incorporating ABS solenoid valve)	B	Turbocharger wastegate solenoid 1	C
Hydraulic unit assembly (incorporating direction valve and proportioning valve)	H	Turbocharger wastegate solenoid 2	C

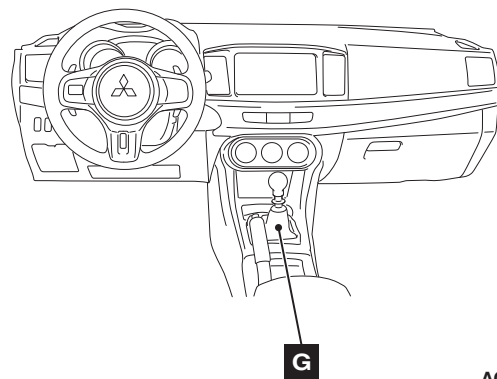
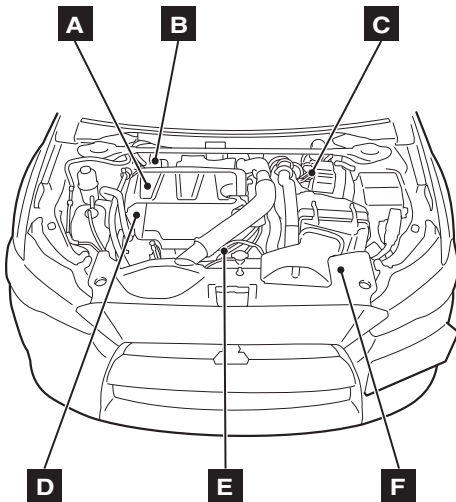

AC708720AE

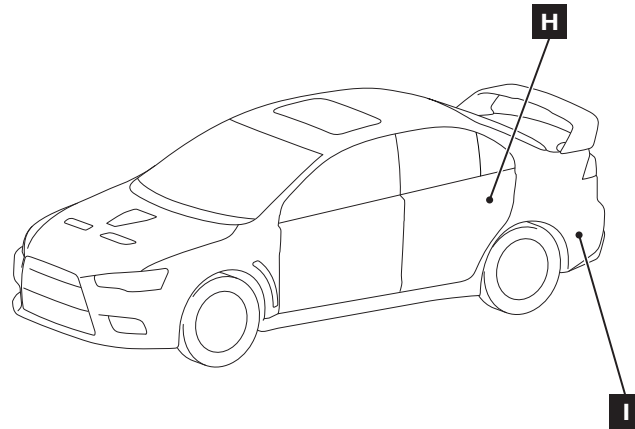

AC705160AG

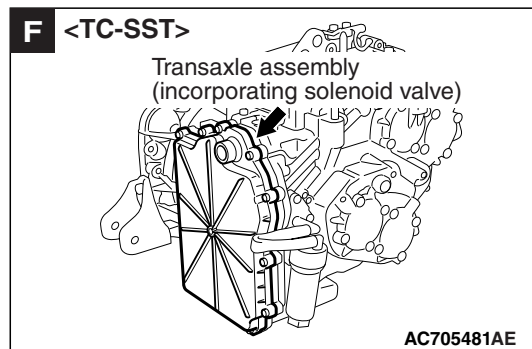
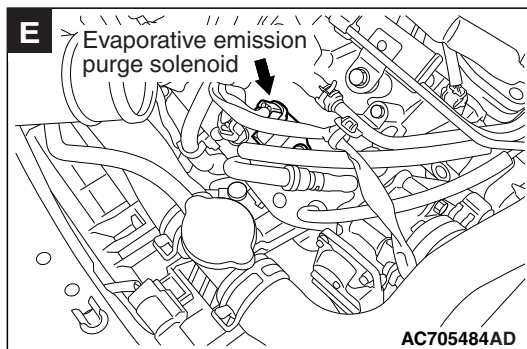
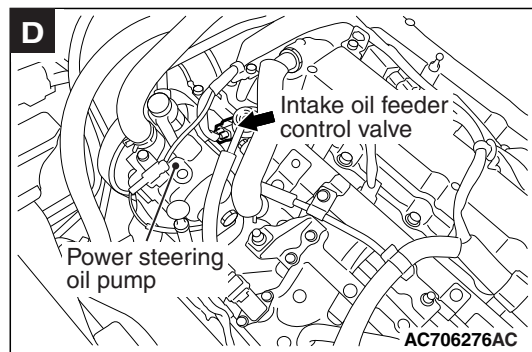
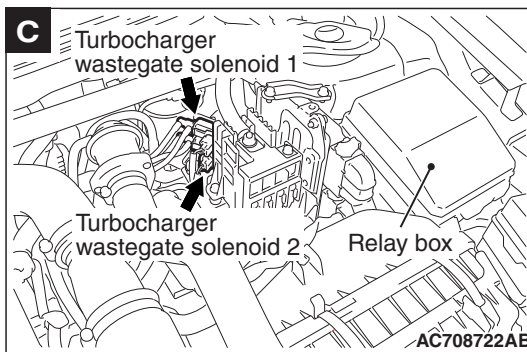
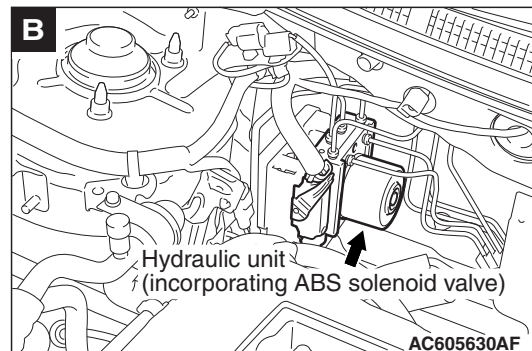
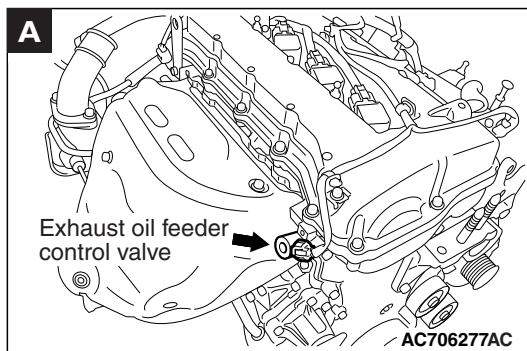

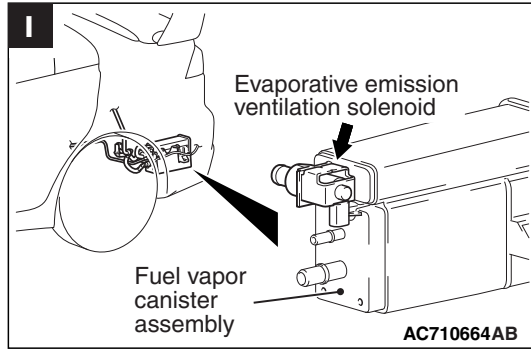
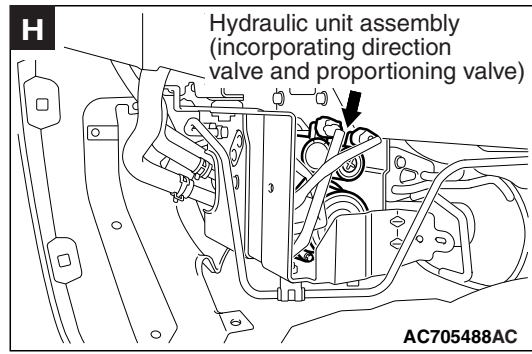
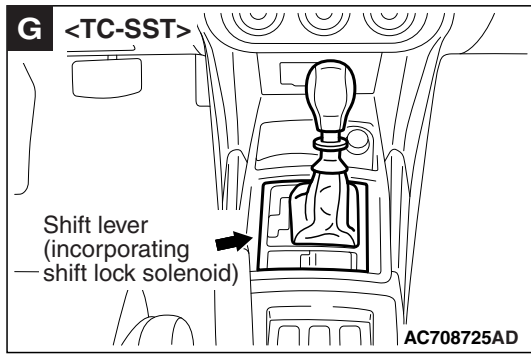

GROUNDING CABLE

M1701001001022

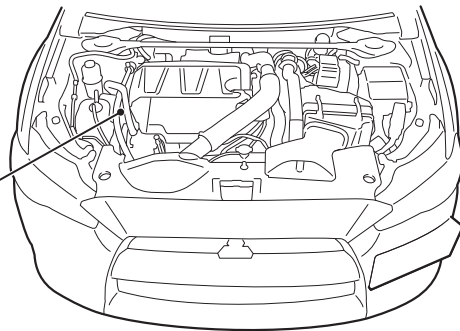
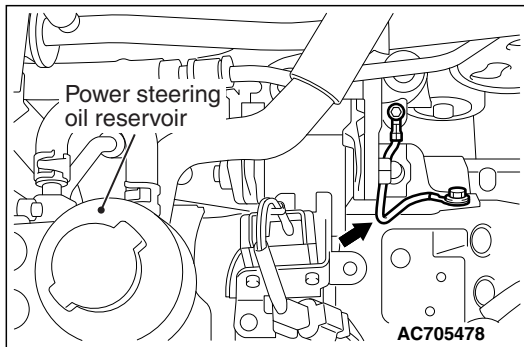

AC708719AB

GROUNDING

M1701000301309

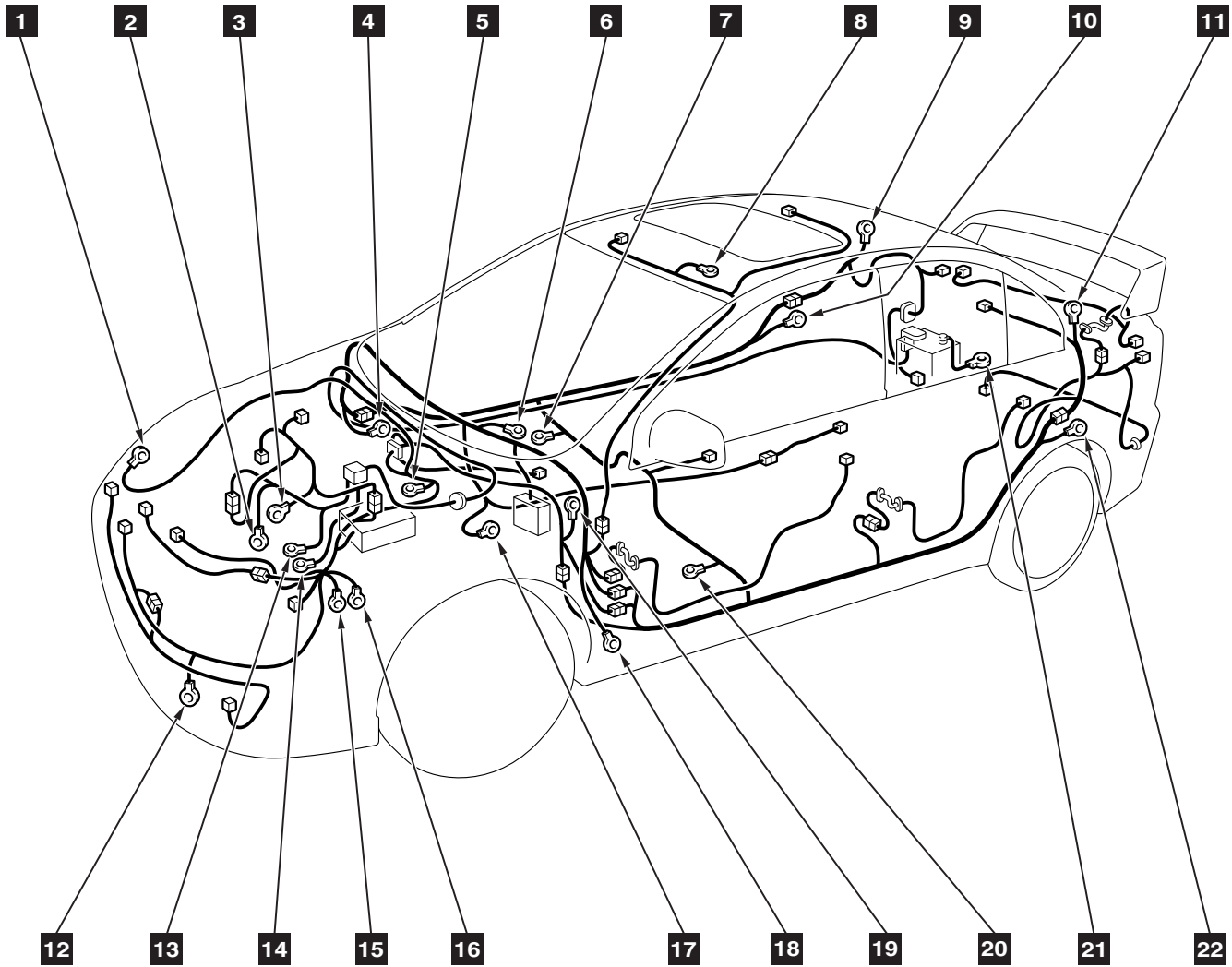

AC708222AC

NOTE: 1 to 22 numbers correspond to the body ground point numbers in CIRCUIT DIAGRAMS.

