

GROUP 25

PROPELLER SHAFT

CONTENTS

GENERAL INFORMATION	25-2	SYMPTOM CHART	25-4
GENERAL SPECIFICATIONS	25-3	SYMPTOM PROCEDURES	25-4
SERVICE SPECIFICATION	25-3	SPECIAL TOOL	25-5
LUBRICANTS	25-3	ON-VEHICLE SERVICE	25-5
ADHESIVE	25-3	PROPELLER SHAFT UNIVERSAL JOINT CHECK	25-5
PROPELLER SHAFT DIAGNOSIS ..	25-4	PROPELLER SHAFT	25-7
INTRODUCTION TO PROPELLER SHAFT DIAGNOSIS	25-4	REMOVAL AND INSTALLATION	25-7
PROPELLER SHAFT DIAGNOSTIC TROUBLESHOOTING STRATEGY	25-4	INSPECTION	25-9
		DISASSEMBLY AND ASSEMBLY	25-10

GENERAL INFORMATION

M1251000100465

The 3-piece, 4-joint type propeller shaft with a center bearing is adopted.

There are the following features.

- For the joint Nos. 1, 2, and 4, the caulking type universal joint with excellent properties of balance accuracy is equipped.
- For joint No. 3, the lightweight and compact LJ (Lebro Joint) is equipped.
- The dual anti-vibration construction is located at the center bearing to vehicle body joint, reducing vibration (gear noise).
- The heat protector is adopted to the center bearing bracket.
- The lead-free grease is adopted for the universal joint and LJ (Lebro Joint).

CONSTRUCTION DIAGRAM

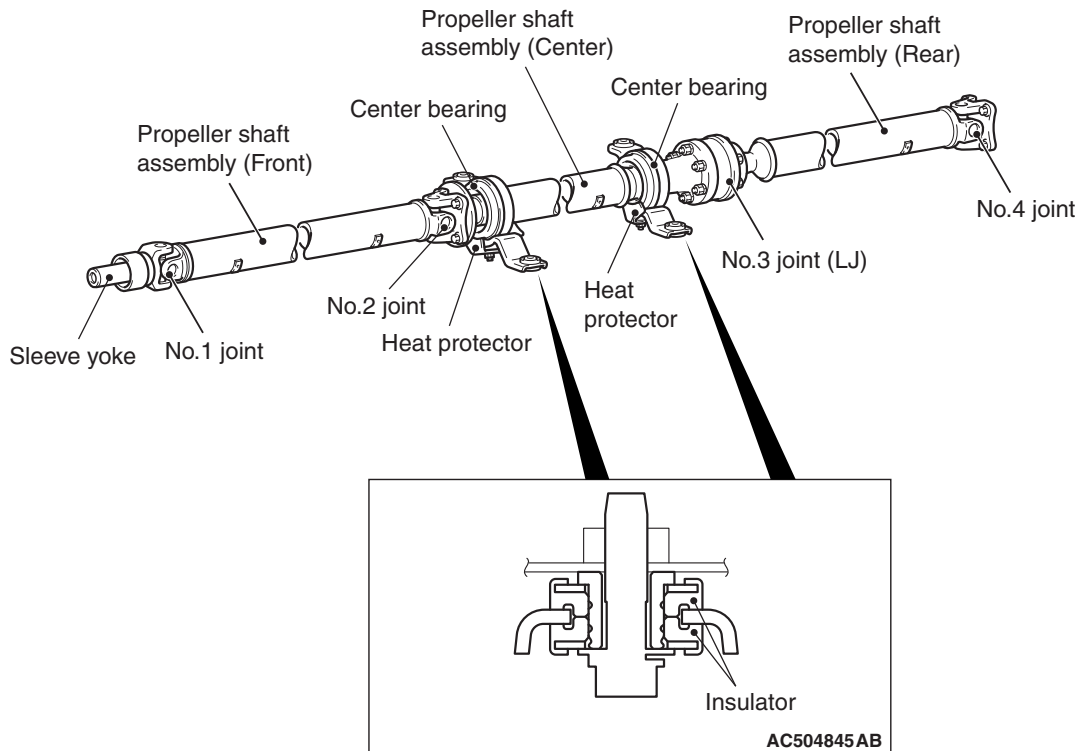

AC704615AB

GENERAL SPECIFICATIONS

M1251000200194

Item		Specification	
Propeller shaft	Type	3-piece, 4-joint type propeller shaft	
	Length* × Outer diameter mm (in)	Front	517 × 65 (20.4 × 2.6)
		Center	708 × 65 (27.9 × 2.6)
		Rear	704 × 65 (27.7 × 2.6)
Universal joint	Type	No.1	Cross type (caulking method)
		No.2	Cross type (caulking method)
		No.3	Constant velocity type (LJ)
		No.4	Cross type (caulking method)
	Bearing	Needle roller bearing (maintenance-free type)	
	Journal diameter mm (in)	18.0 (0.71)	

NOTE: *: Indicates the distance between each joint center.

SERVICE SPECIFICATION

M1251000300373

Item	Limit
Propeller shaft runout mm (in)	0.5 (0.02)

LUBRICANTS

M1251000400507

Item	Specified lubricant	Quantity
Front propeller shaft sleeve yoke	Dia Queen LSD gear oil	As required
LJ assembly	Repair kit grease	75 ± 5 g (2.6 ± 0.1 oz)

ADHESIVE

M1251000500151

Item	Specified adhesive	Quantity
LJ assembly rubber packing	3M™ AAD Part No. 8730, 8731 or equivalent	As required

PROPELLER SHAFT DIAGNOSIS

INTRODUCTION TO PROPELLER SHAFT DIAGNOSIS

M1251001800111

If an abnormal noise is heard from the propeller shaft while driving, some parts of the propeller shaft may be worn or damaged, or some mounting bolts may be loose.

PROPELLER SHAFT DIAGNOSTIC TROUBLESHOOTING STRATEGY

M1251001900129

Use these steps to plan your diagnostic strategy. If you follow them carefully, you will be sure that you have exhausted all of the possible ways to find a propeller shaft fault.

1. Gather information from the customer.

2. Verify that the condition described by the customer exists.
3. Find the malfunction by following the Symptom Chart.
4. Verify malfunction is eliminated.

SYMPTOM CHART

M1251002000107

Symptom	Inspection procedure	Reference page
Noise at start	1	P.25-4
Noise and vibration at high speed	2	P.25-5

SYMPTOM PROCEDURES

INSPECTION PROCEDURE 1: Noise at Start

DIAGNOSIS

STEP 1. Check if the propeller shaft flange yoke and rear differential connecting nuts and the center bearing mounting nuts are loose.

Propeller shaft flange yoke and rear differential connecting nuts tightening torque: 54 ± 5 N·m (40 ± 4 ft-lb)

Center bearing mounting nuts tightening torque: 41 ± 5 N·m (30 ± 3 ft-lb)

Q: Are the connecting nuts and mounting nuts tightened to the specified torque?

YES : Go to Step 2.

NO : Tighten the connecting nuts and mounting nuts to the specified torque. Then go to Step 3.

STEP 2. Check the sleeve yoke's spline of front propeller shaft for wear.

Q: Is wear apparent?

YES : Replace the propeller shaft. Then go to Step 3.

NO : Go to Step 3.

STEP 3. Retest the system.

Q: Is the abnormal noise eliminated?

YES : The procedure is complete.

NO : Recheck from Step 1.

INSPECTION PROCEDURE 2: Noise and Vibration at High Speed

DIAGNOSIS

STEP 1. Check the propeller shaft run-out.

- (1) Remove the propeller shaft. (Refer to P.25-7.)
- (2) Measure the propeller shaft runout.

Limit: 0.5 mm (0.02 inch)

Q: Is the measured value within the limit?

YES : Go to Step 2.

NO : Replace the propeller shaft. Then go to Step 2.

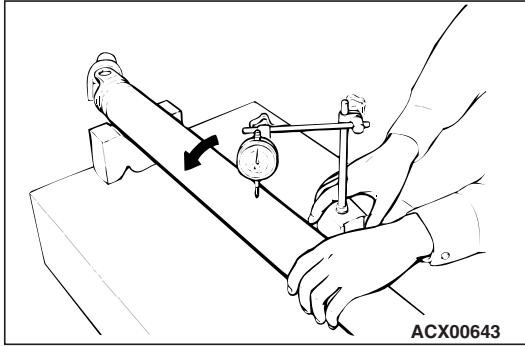

STEP 2. Retest the system.

Q: Is the abnormal noise eliminated?

YES : The procedure is complete.

NO : Recheck from Step1.

SPECIAL TOOL

M125100600352

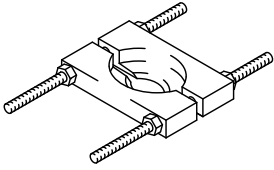
Tool	Tool number and name	Supersession	Application
	MD998801 Bearing remover	-	Removal of the center bearing assembly

ON-VEHICLE SERVICE

PROPELLER SHAFT UNIVERSAL JOINT CHECK

M1251002400150

PROPELLER SHAFT VISUAL CHECK

- 1. Place the gearshift lever to the "N" position.
- 2. Check the propeller shaft for dent, damage or crack.

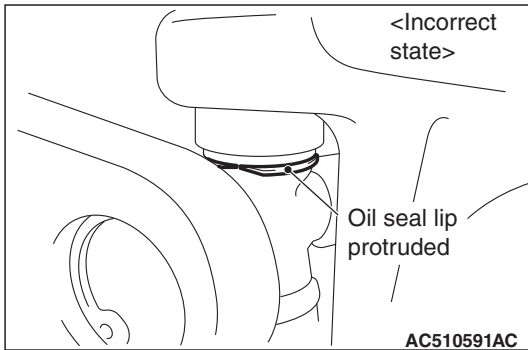
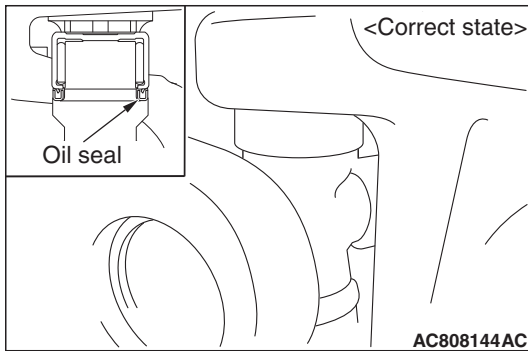

3. Check the propeller shaft universal joint, oil seal for crack or damage. If abnormality is recognized, replace the propeller shaft with a new one.

PROPELLER SHAFT UNIVERSAL JOINT PLAY CHECK

1. Place the gearshift lever to the "N" position.
2. Hold the tube of propeller shaft by one hand, and apply force by the other hand to the flange yoke or sleeve yoke in rotating direction, axial direction, and perpendicular direction for checking looseness. If looseness is recognized, replace the propeller shaft with a new one.

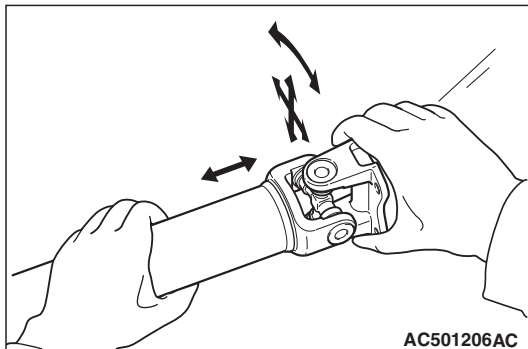

PROPELLER SHAFT UNIVERSAL JOINT FLECTION CHECK

1. Place the gearshift lever to the "N" position.
2. Make phase alignment marks on the flange yoke and differential companion flange and disconnect the flange yoke.

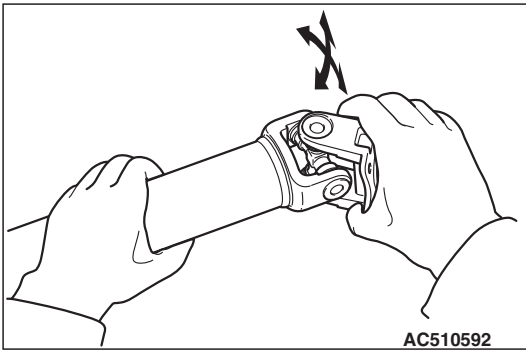

3. Hold the tube of propeller shaft by one hand, and apply force by the other hand to the flange yoke in flexion direction for checking flexion. If showing a sign of catch in the flexion direction is recognized, replace the propeller shaft with a new one.

PROPELLER SHAFT

REMOVAL AND INSTALLATION

M1251001000698

Pre-removal and Post-installation operation

- Engine Room Under Cover Front A, Engine Room Under Cover Center, Engine Room Under Cover Front B Removal and Installation (Refer to GROUP 51, Under Cover P.51-15.)
- Transfer Oil Draining and Filling (Refer to GROUP 22A, On-vehicle Service, Transfer Fluid Change P.22A-119.), (Refer to GROUP 22C, On-vehicle Service, Transfer Fluid Change P.22C-400.)

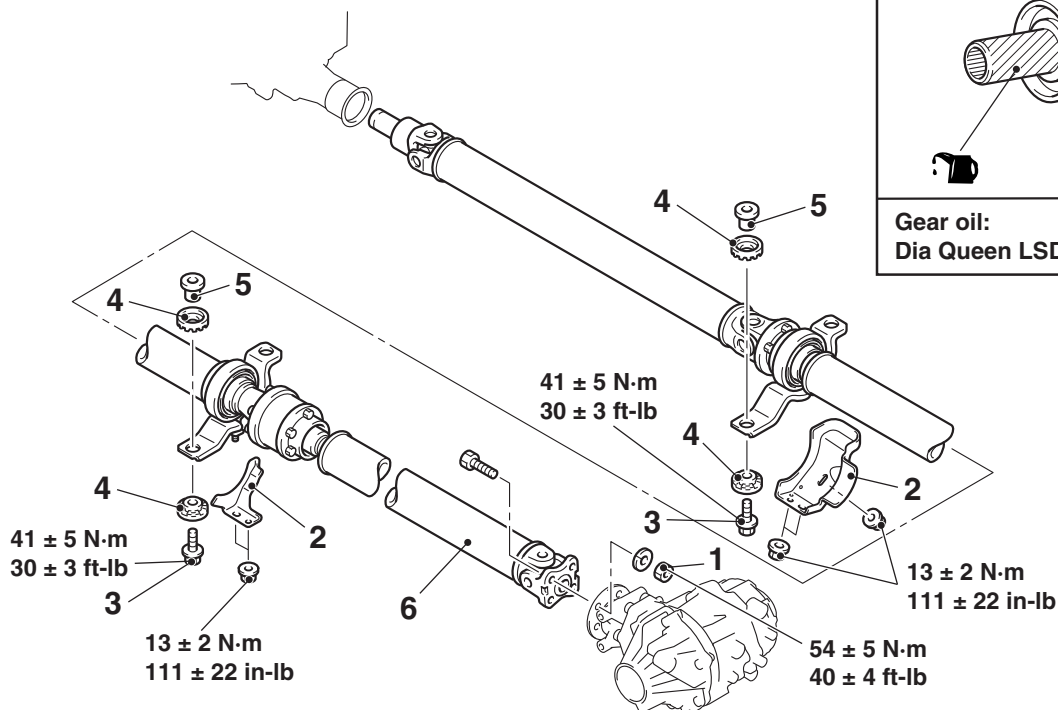
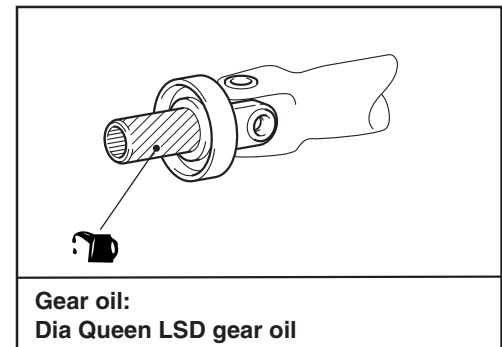

AC704739AB

- <<A>> >>B<<
1. Propeller shaft flange yoke and rear differential connection nut
 2. Heat protector

Removal steps (Continued)

3. Bolt
4. Insulator
5. Spacer
6. Propeller shaft assembly

<> >>A<<

TSB Revision

REMOVAL SERVICE POINTS

<<A>> PROPELLER SHAFT FLANGE YOKE AND REAR DIFFERENTIAL CONNECTION NUT

Put mating marks on the flange yoke and the differential companion flange and remove the connecting nuts.

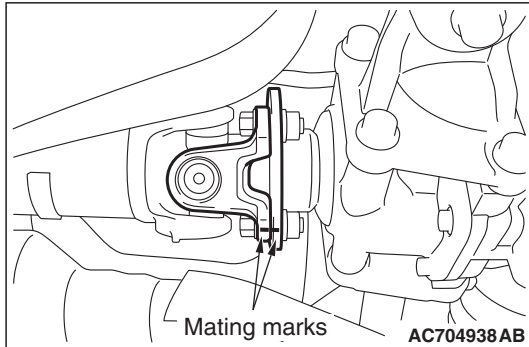

<> PROPELLER SHAFT ASSEMBLY REMOVAL

⚠ CAUTION

If the joint assembly is bent, it may be damaged when pinching the joint boots.

Insert a rag or similar materials into the joint boots, and remove the propeller shaft assembly by aligning the front propeller shaft with the rear shaft.

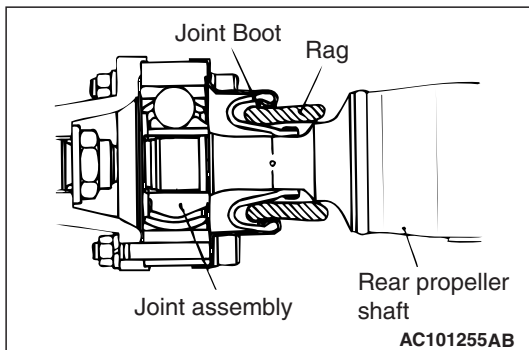

INSTALLATION SERVICE POINTS

>>A<< PROPELLER SHAFT ASSEMBLY INSTALLATION

⚠ CAUTION

- Do not damage the oil seal lip of the transfer.
- The mounting bolt and nut may be loosened if oil or grease is stuck on the threads of the bolt and nut. Tighten them after degreasing the threads.
- If the joint assembly is bent, it may be damaged when pinching the joint boots.

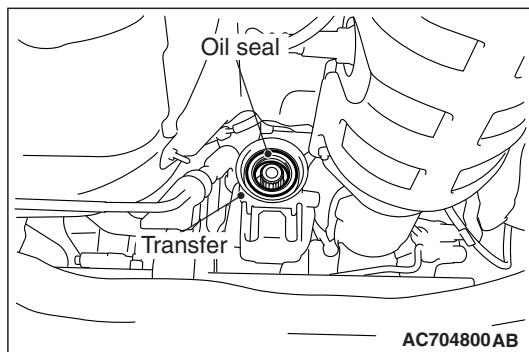

>>B<< PROPELLER SHAFT FLANGE YOKE AND REAR DIFFERENTIAL CONNECTION NUT INSTALLATION

If the propeller shaft is reused, align the mating marks and install the connecting nuts.

Tightening torque: 54 ± 5 N·m (40 ± 4 ft-lb)

INSPECTION

M1251001100435

PROPELLER SHAFT RUNOUT

Check the deflection of the front, center and rear shafts.

Limit: 0.5 mm (0.02 inch)

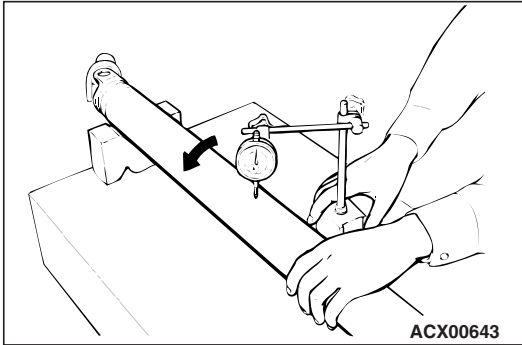

DISASSEMBLY AND ASSEMBLY

M1251001200249

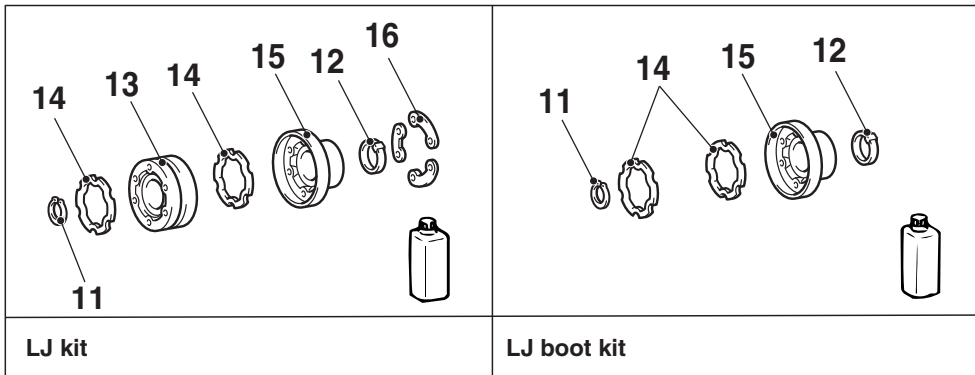
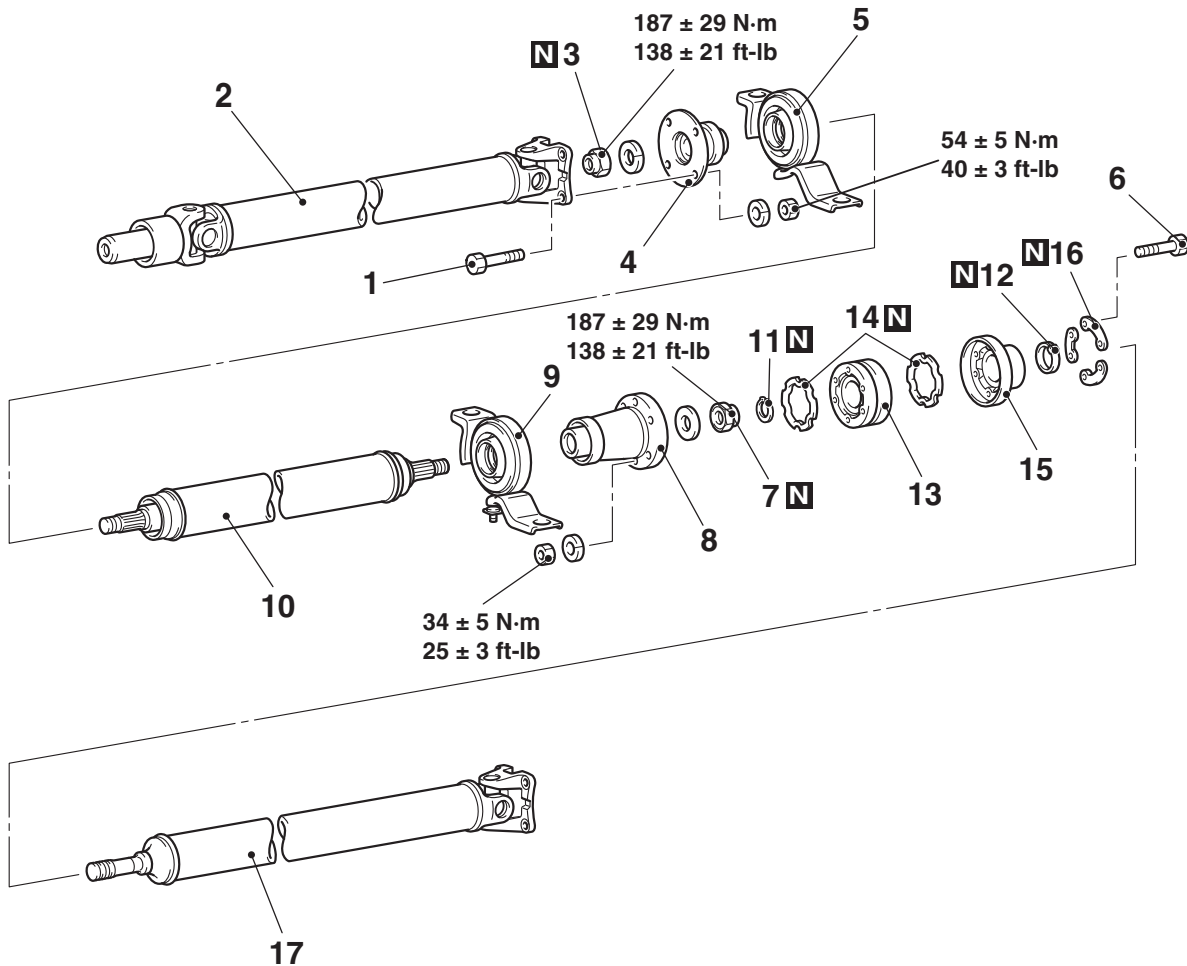

AC704786AB

Disassembly steps

- 1. Bolt
- 2. Front propeller shaft assembly
- <<A>> >>E<< 3. Self locking nut
- <> >>E<< 4. Companion flange
- <<C>> >>E<< 5. Center bearing assembly
- >>D<< 6. Bolt
- <<A>> >>D<< 7. Self locking nut
- <> >>D<< 8. Companion flange
- 9. Center bearing assembly
- 10. Center propeller shaft

Disassembly steps (Continued)

- >>C<< 11. Snap ring
- <<D>> >>B<< 12. Boot band
- <<E>> >>A<< 13. LJ assembly
- 14. Rubber packing
- 15. LJ boot
- 16. Washer
- 17. Rear propeller shaft assembly

Required Special Tool:

- MD998801: Bearing Remover

LUBRICATION AND ADHESIVE POINTS

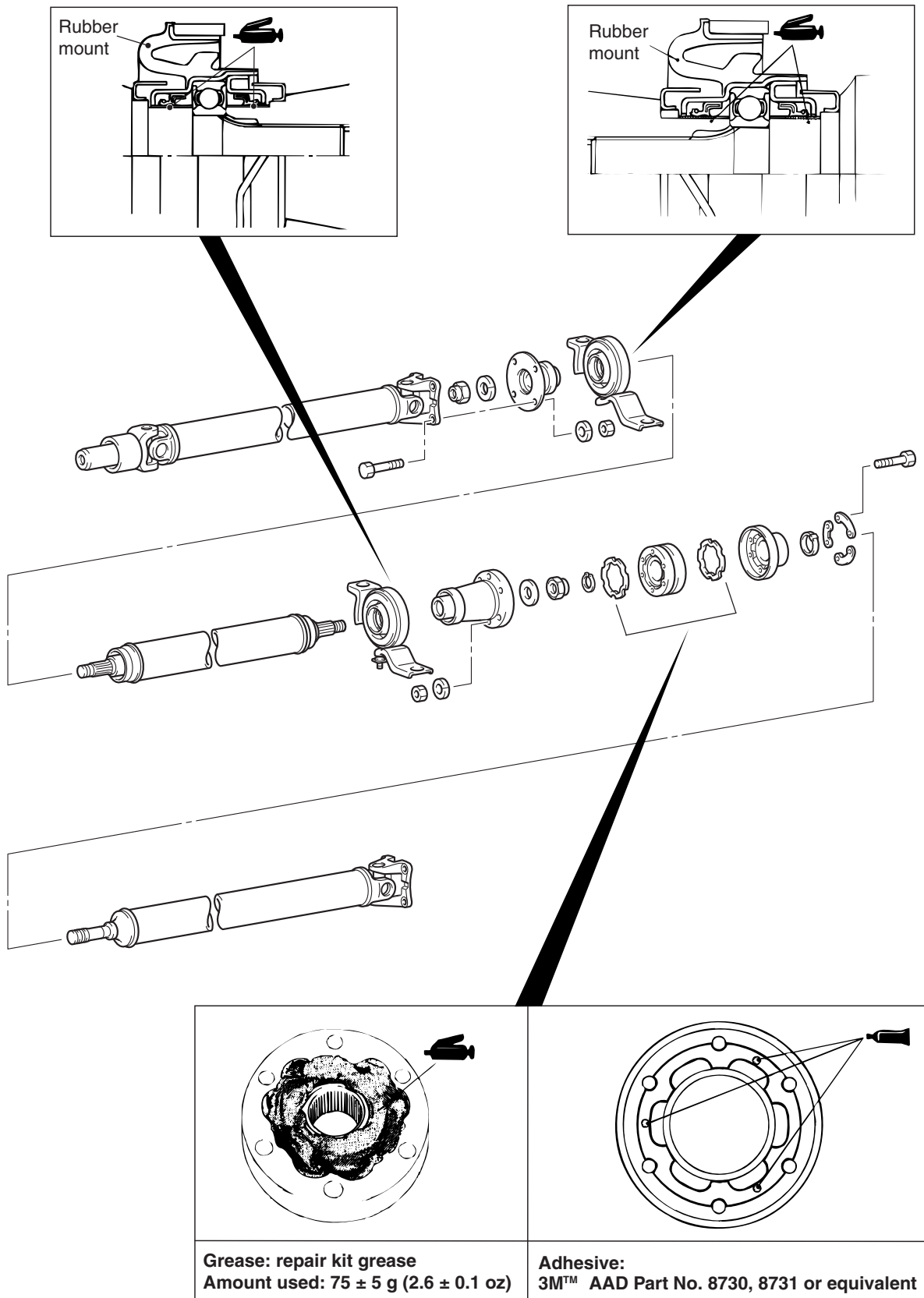

AC705050AB

DISASSEMBLY SERVICE POINTS**<<A>> COMPANION FLANGE REMOVAL**

Make mating marks on the companion flange and center propeller shaft, and then remove the companion flange.

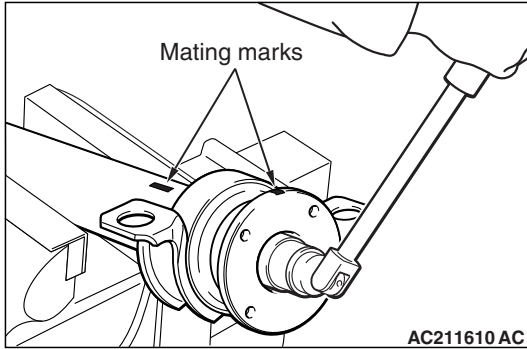
**<> CENTER BEARING ASSEMBLY REMOVAL**

Use special tool MD998801 to remove the center bearing assembly from the center propeller shaft.

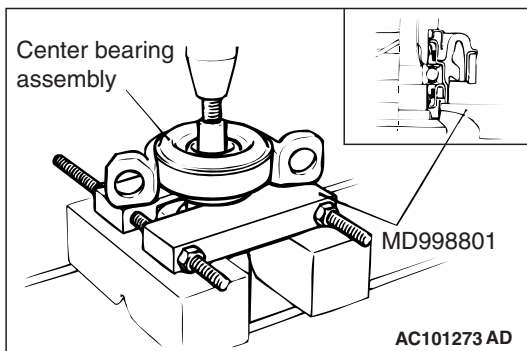
**<<C>> BOLT REMOVAL**

Make mating marks on the rear propeller shaft, LJ assembly and companion flange, and then remove the bolt.

<<D>> LJ ASSEMBLY REMOVAL

1. Remove the LJ boot from the LJ assembly.

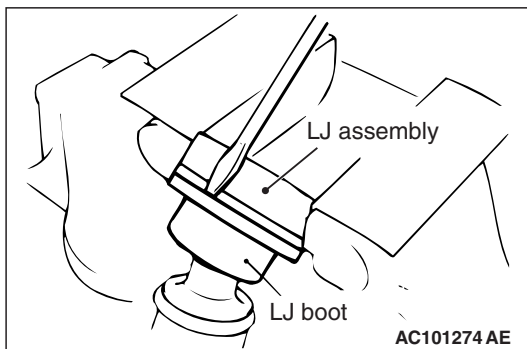

2. Make mating marks on the outer race, cage and inner race, and then remove the outer race and ball.

NOTE: Note the positions of the balls so that they can be reinstalled in their original positions.

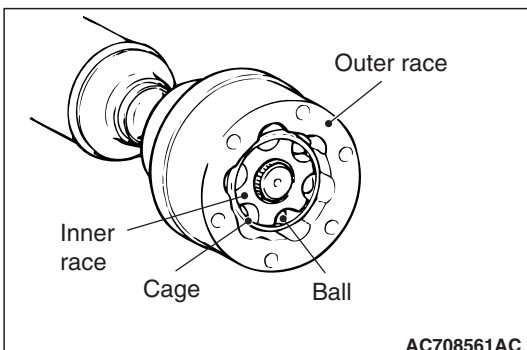

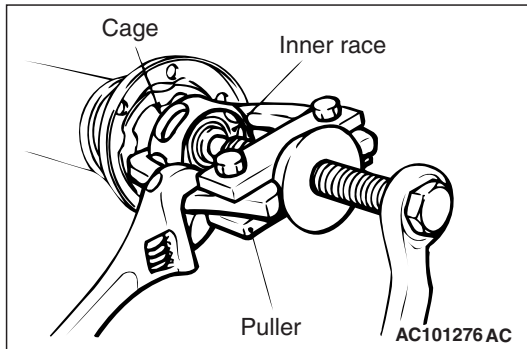

3. Remove the inner race with cage from the rear propeller shaft assembly by using a puller (commercially available).
4. Wipe off the grease and clean the outer race, inner race, cage and balls.

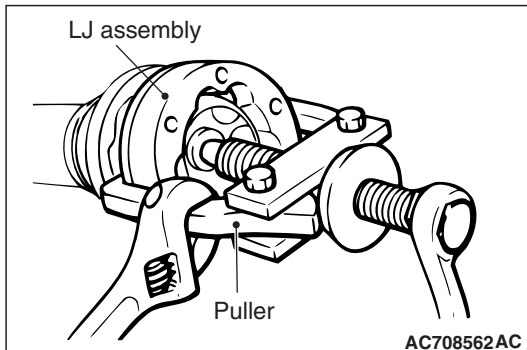

5. If it is not possible to disassemble the outer race of LJ assembly, remove the LJ assembly from the rear propeller shaft assembly by using a puller (commercially available).

<<E>> LJ BOOT REMOVAL

When the LJ boot is reused, tape the spline part on the rear propeller shaft and then remove the LJ boot.

ASSEMBLY SERVICE POINTS

>>A<< LJ BOOT INSTALLATION

1. Install the boot band.
2. Wrap a plastic tape around the spline part on the rear propeller shaft and then install the LJ boot.

>>B<< LJ ASSEMBLY INSTALLATION

1. Apply a thin coat of the specified grease to the ball grooves of the inner and outer races.

Specified grease: Repair kit grease

2. Assemble the LJ assembly outer race, cage, balls, and inner race with their mating marks aligned.

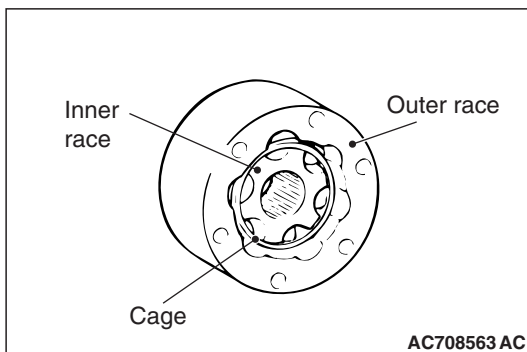

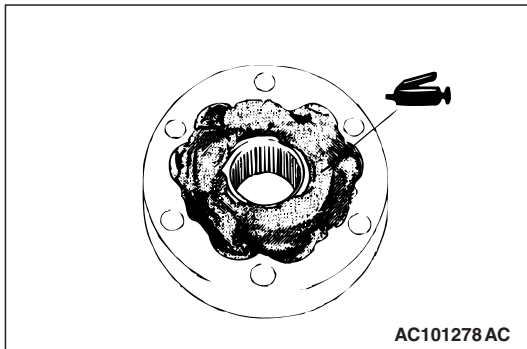

3. Apply specified grease to the LJ assembly.
Specified grease: Repair kit grease
Amount to use: 75 ± 5 g (2.6 ± 0.1 ounces)

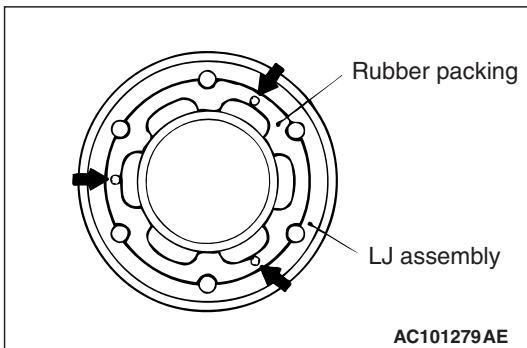

4. Apply a little of the specified adhesive to the surface which has groove (for packing) of LJ assembly (shown by arrows in the illustration), fix the rubber packing.
Specified adhesive: 3M™ AAD Part No. 8730, 8731 or equivalent
5. Set the groove side of LJ assembly (for packing) toward the LJ boot side and install them.

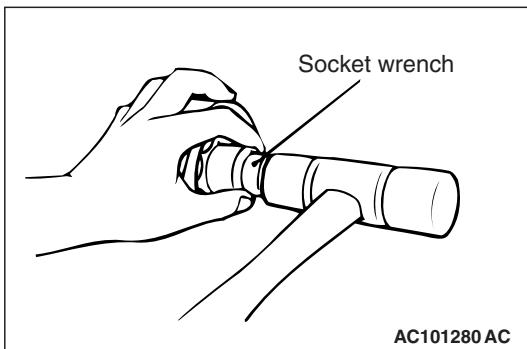

6. Align the mating marks of LJ assembly and rear propeller shaft, then install the LJ assembly to rear propeller shaft using socket wrench.

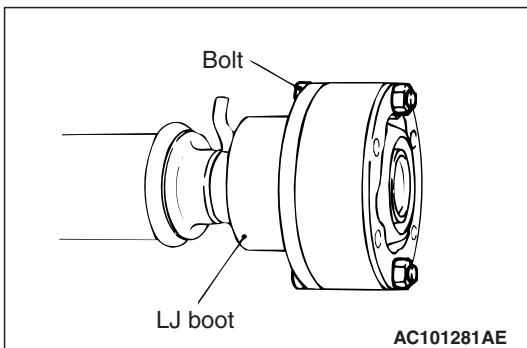

7. Using the bolt, align the bolt holes of the LJ boot and the LJ assembly and install LJ boot to the LJ assembly.
8. Install the rubber packing of the companion flange side in the same manner as described in (4) above.

>>C<< BOOT BAND INSTALLATION

⚠ CAUTION

- Tighten the boot part in opposite direction of convex part for bleeding the boot.
- If there is grease in the convex part, wipe out the grease in order to bleed the boot.

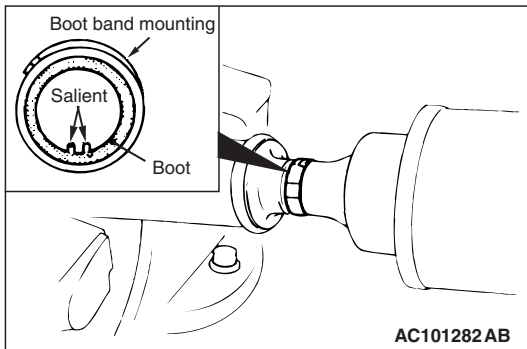

>>D<< CENTER BEARING ASSEMBLY/COMPANION FLANGE/SELF LOCKING NUT INSTALLATION

1. Install the center bearing assembly to the center propeller shaft in the direction shown in the illustration.
2. After aligning the mating marks of the companion flange and center propeller shaft, install them.
3. Tightening the self locking nut, press fit the center bearing assembly using companion flange.

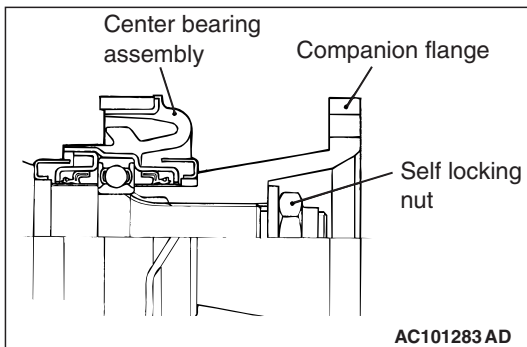

>>E<< CENTER BEARING ASSEMBLY/COMPANION FLANGE/SELF LOCKING NUT INSTALLATION

1. Install the center bearing assembly to the center propeller shaft in the direction shown in the illustration.
2. After aligning the mating marks of the companion flange and center propeller shaft, install them.
3. Tightening the self locking nut, press fit the center bearing assembly using companion flange.

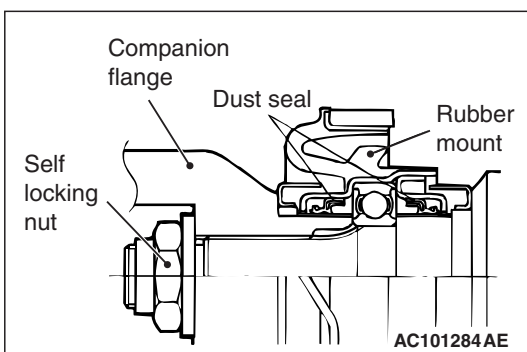

NOTES