

GROUP 34

REAR SUSPENSION

CONTENTS

GENERAL INFORMATION	34-2	CONTROL LINK BALL JOINT DUST COVER REPLACEMENT	34-16
FASTENER TIGHTENING SPECIFICATIONS	34-4	TRAILING ARM	34-17
GENERAL SPECIFICATIONS	34-4	REMOVAL AND INSTALLATION	34-17
SERVICE SPECIFICATIONS	34-5	TRAILING ARM BALL JOINT ROTATION STARTING TORQUE CHECK	34-19
LUBRICANTS	34-5	TRAILING ARM BALL JOINT DUST COVER INSPECTION	34-19
REAR SUSPENSION DIAGNOSIS ..	34-6	TRAILING ARM PILLOW BALL BUSHING ROTATION TORQUE CHECK	34-19
INTRODUCTION TO REAR SUSPENSION DIAGNOSIS	34-6	TRAILING ARM BALL JOINT DUST COVER REPLACEMENT	34-20
REAR SUSPENSION DIAGNOSTIC TROUBLESHOOTING STRATEGY	34-6	UPPER ARM ASSEMBLY	34-21
SYMPTOM CHART	34-6	REMOVAL AND INSTALLATION	34-21
SYMPTOM PROCEDURES	34-6	UPPER ARM BALL JOINT ROTATION STARTING TORQUE CHECK	34-22
SPECIAL TOOLS	34-8	UPPER ARM BALL JOINT DUST COVER INSPECTION	34-22
ON-VEHICLE SERVICE	34-9	UPPER ARM PILLOW BALL BUSHING ROTATION TORQUE CHECK	34-22
REAR WHEEL ALIGNMENT CHECK AND ADJUSTMENT	34-9	UPPER ARM BALL JOINT DUST COVER REPLACEMENT	34-23
BALL JOINT DUST COVER INSPECTION	34-10	SHOCK ABSORBER ASSEMBLY ...	34-24
CONTROL LINK AND LOWER ARM 34-12	34-12	REMOVAL AND INSTALLATION	34-24
REMOVAL AND INSTALLATION	34-12	DISASSEMBLY AND ASSEMBLY	34-25
CONTROL LINK BALL JOINT ROTATION STARTING TORQUE CHECK	34-14	STABILIZER BAR	34-28
CONTROL LINK SLIDE BUSHING ROTATION STARTING TORQUE CHECK	34-15	REMOVAL AND INSTALLATION	34-28
CONTROL LINK BALL JOINT DUST COVER INSPECTION	34-15	STABILIZER LINK CHECK	34-29
LOWER ARM PILLOW BALL BUSHING ROTATION STARTING TORQUE CHECK	34-15	REAR SUSPENSION CROSSMEMBER	34-30
		REMOVAL AND INSTALLATION	34-30

GENERAL INFORMATION

M1341000101312

The low mount multi link suspension has been adopted.

There are the following features.

IMPROVEMENT IN SUSPENSION POSITIONING RIGIDITY

- The arm layout has been optimized. (Each arm support span has been widened.)
- The rigidity of the arm installation part has been improved. (Better rigidity of crossmember, addition of trailing arm bracket)

IMPROVEMENT IN CORNERING PERFORMANCE

- The 18-inch low-aspect ratio tire has been equipped, the wheel tread has been widened, and the suspension rigidity has been improved, for better cornering performance and cornering limit.
- By adopting the non-linear coil spring, the sufficient wheel stroke has been secured, and the cornering stability not affected by the road condition has been obtained.
- Cornering performance has been optimized by selecting the stabilizer diameter.

IMPROVEMENT IN STROKE FEELING

- The numbers of pillow ball bush and ball joint on the arm installation part have been increased for the better road-holding quality of the suspension.

IMPROVEMENT IN DAMPING FEELING

- The shock absorber, which is arranged on the same axle for the coil spring, has been mounted with a knuckle for better absorber efficiency.

- The shock absorber installation angle has been optimized.

IMPROVEMENT IN QUALITY

- The Bilstein shock absorber and the Eibach coil spring* have been established.<GSR: optional equipment, MR: standard equipment>
*NOTE: *: The Eibach coil spring has widely been adopted in the motor sport field; sports vehicles in Europe, F1, WRC, etc.*

IMPROVEMENT IN ALIGNMENT ACCURACY

- Arms have been installed to the lattice cross-member, and the rear suspension has been broken down into sub assembly for the better alignment accuracy.

WEIGHT SAVING

- The aluminum forged upper arm, trailing arm, and control link have been adopted for weight reduction and high rigidity.
- The light weight lower arm made with a steel pipe has been employed.

HEXAVALENT CHROMIUM-FREE COMPONENT

- Hexavalent chromium has been eliminated from bolts and nuts.

LEAD-FREE COMPONENT

- The lead-free grease has been adopted for the ball joint.

CONSTRUCTION DIAGRAM

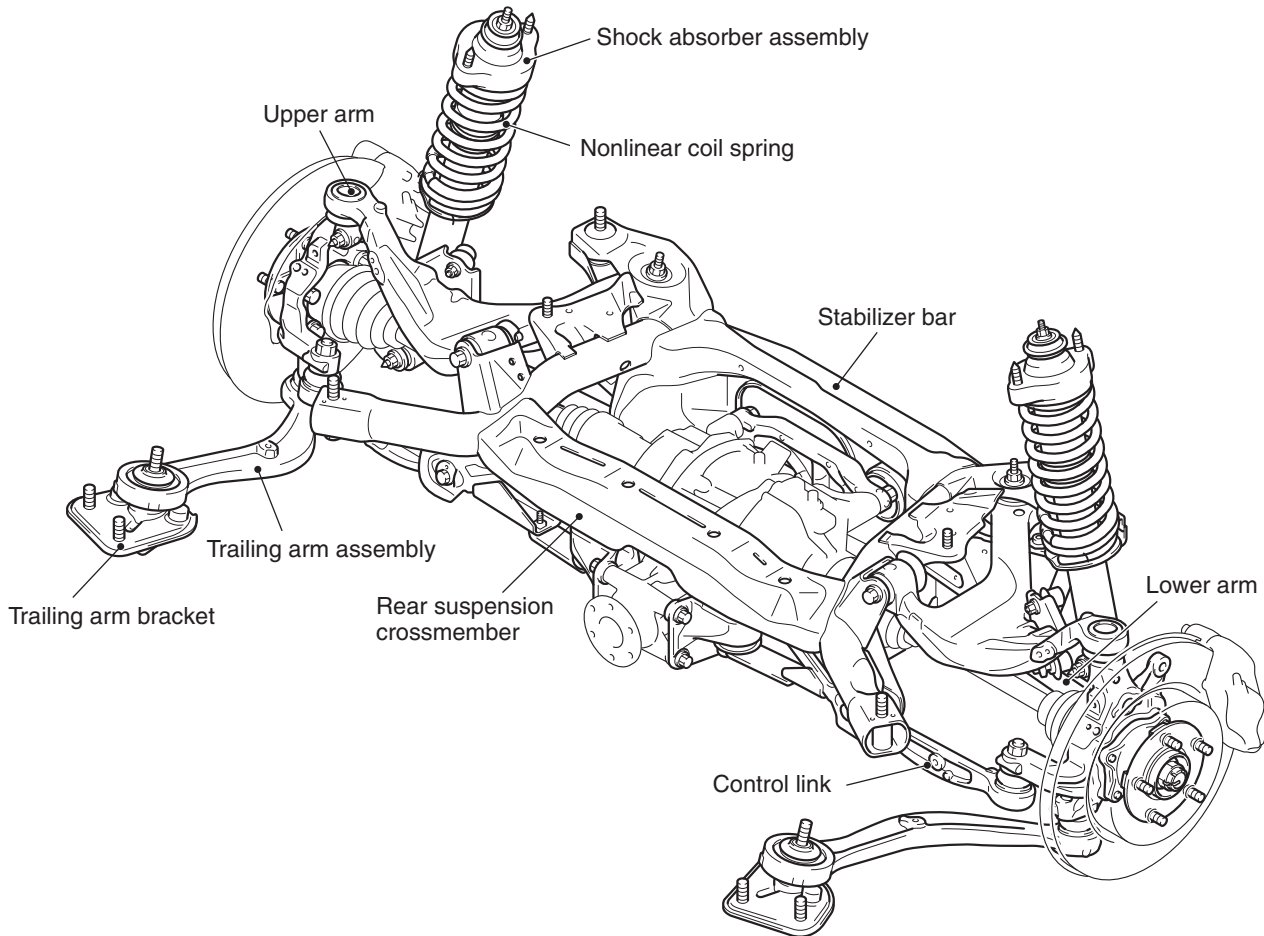
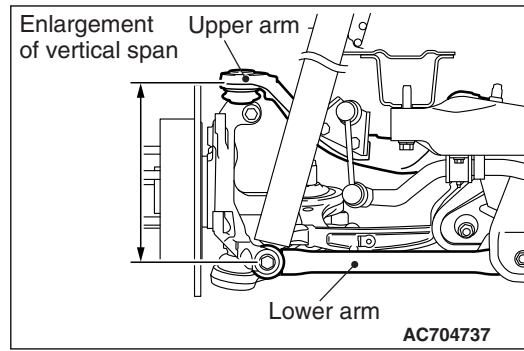
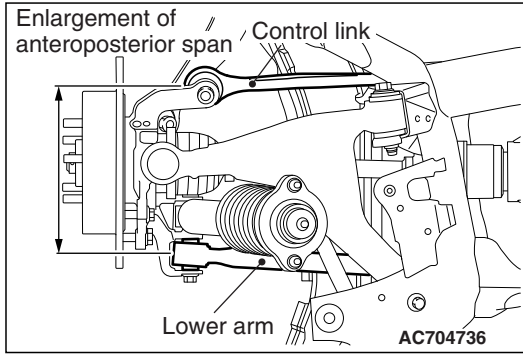

AC710561AB

FASTENER TIGHTENING SPECIFICATIONS

M1341012700448

Item	Specification
Control link	
Control link to knuckle nut	81 ± 6 N· m (60 ± 4 ft-lb)
Control link to crossmember nut	71 ± 10 N· m (52 ± 7 ft-lb)
Lower arm	
Lower arm to crossmember nut	71 ± 10 N· m (52 ± 7 ft-lb)
Lower arm to knuckle nut	71 ± 10 N· m (52 ± 7 ft-lb)
Rear suspension crossmember	
Crossmember bracket mounting bolt	71 ± 10 N· m (52 ± 7 ft-lb)
Crossmember stay mounting bolt	11 ± 3 N· m (97 ± 27 in-lb)
Shock absorber assembly	
Shock absorber assembly to body nut	45 ± 7 N· m (33 ± 5 ft-lb)
Shock absorber assembly to knuckle nut	71 ± 10 N· m (52 ± 7 ft-lb)
Self-locking nut	25 ± 5 N· m (19 ± 3 ft-lb)
Stabilizer bar	
Stabilizer bar link nut	39 ± 6 N· m (29 ± 4 ft-lb)
Stabilizer bracket bolt	39 ± 6 N· m (29 ± 4 ft-lb)
Stabilizer clamp bolt	31 ± 4 N· m (23 ± 2 ft-lb)
Trailing arm	
Trailing arm to knuckle nut	81 ± 6 N· m (60 ± 4 ft-lb)
Trailing arm bracket to body bolt	110 ± 11 N· m (81 ± 8 ft-lb)
Trailing arm to body bolt	110 ± 11 N· m (81 ± 8 ft-lb)
Parking brake cable to trailing arm bolt	11 ± 2 N· m (98 ± 17 in-lb)
Upper arm	
Upper arm to crossmember bolt	110 ± 11 N· m (81 ± 8 ft-lb)
Upper arm assembly to knuckle	71 ± 10 N· m (52 ± 2 ft-lb)
Rear wheel speed sensor cable to upper arm bolt	11 ± 2 N· m (98 ± 17 in-lb)
Rear wheel speed sensor mounting bolt	8.5 ± 1.5 N· m (76 ± 13 in-lb)

GENERAL SPECIFICATIONS

M1341000200457

COIL SPRING

Item	GSR	MR
Wire diameter mm (in)	11 (0.4)	11 (0.4)
Mean diameter of coil mm (in)	79 -87 (3.1 -3.4)	79 -87 (3.1 -3.4)
Free length mm (in)	361 (14.2), 357 (14.0)*	357 (14.0)

NOTE: *: Optional equipment

SERVICE SPECIFICATIONS

M1341000300993

Item	Standard value
Toe in mm (in)	3 ± 2 (0.12 ± 0.08)
Camber	-1° 00' ± 0° 30' (Difference between right and left within 0° 30')
Control link ball joint rotation starting torque N· m (in-lb)	0.5 -2.5 (4.5 -22.1)
Control link slide bushing rotation starting torque N· m (in-lb)	2.0 (17.7) or less
Lower arm pillow ball bushing rotation starting torque N· m (in-lb)	Rear suspension crossmember side: 3.0 (26.5) or less, Knuckle side: 9.8 (86.7) or less
Trailing arm ball joint rotation starting torque N· m (in-lb)	0.5 -2.5 (4.5 -22.1)
Trailing arm pillow ball bushing rotation torque N· m (in-lb)	1.5 (13.2) or less
Upper arm ball joint rotation starting torque N· m (in-lb)	3.4 (30.0) or less
Upper arm pillow ball bushing rotation torque N· m (in-lb)	1.5 (13.2) or less
Stabilizer link ball joint rotation torque N· m (in-lb)	10 -30° C (50 -86° F): 0.2 -2.0 (1.8 -17.7) Other than 10 -30° C (50 -86° F): 0.2 -5.0 (1.8 -44.2)

LUBRICANTS

M1341000400321

Item	Specified lubricant	Quantity
Inside of control link ball joint dust cover and lip part	Multipurpose grease SAE J310, NLGI No.2 or equivalent	Inside of dust cover: Approx. 7g (0.247 oz) Lip part: As required
Inside of trailing arm ball joint dust cover and lip part		Inside of dust cover: Approx. 7g (0.247 oz) Lip part: As required
Inside of upper arm ball joint dust cover and lip part		Inside of dust cover: 9.0 -10.0 g (0.32 -0.35 oz) Lip part: As required

REAR SUSPENSION DIAGNOSIS

INTRODUCTION TO REAR SUSPENSION DIAGNOSIS

M1341013100160

If the rear suspension is faulty, the vehicle will not run straightforward or noise will occur. Incorrect wheel alignment, malfunction of shock absorber, stabilizer bar, coil spring, control arms or worn or out-of-balance will cause these problems.

REAR SUSPENSION DIAGNOSTIC TROUBLESHOOTING STRATEGY

M1341013200275

Use these steps to plan your diagnostic strategy. If you follow them thoroughly, you will be sure that you have exhausted most of the possible ways to find a rear suspension fault.

1. Gather information from the customer.

2. Verify that the condition described by the customer exists.
3. Find the malfunction by following the Symptom Chart.
4. Verify malfunction is eliminated.

SYMPTOM CHART

M1341013500306

Symptom	Inspection procedure	Reference page
Squeaks or other abnormal noise	1	P.34-6
Poor ride	2	P.34-7
Body tilting	3	P.34-7

SYMPTOM PROCEDURES

INSPECTION PROCEDURE 1: Squeaks or other Abnormal Noise

DIAGNOSIS

STEP 1. Check for loose rear suspension installation bolts and nuts.

Q: Are the rear suspension installation bolts and nuts loose?

YES : Retighten them, and then go to Step 5.

NO : Go to Step 2.

STEP 2. Check the condition of the shock absorbers (worn bushings).

Q: Are the shock absorbers (bushings) in good condition?

YES : Go to Step 3.

NO : Replace the faulty part, and then go to Step 5.

STEP 3. Check the upper arms and/or lower arms and/or control links for deformity or damage.

Q: Are the upper arms and/or lower arms and/or control links in good condition?

YES : Go to Step 4.

NO : Replace the faulty part, and then go to Step 5.

STEP 4. Check the trailing arms for deformity or damage.

Q: Are the trailing arms in good condition?

YES : Go to Step 5.

NO : Replace the faulty part, and then go to Step 5.

STEP 5. Retest the system.

Q: Is the malfunction eliminated?

YES : The procedure is complete.

NO : Return to Step 1.

INSPECTION PROCEDURE 2: Poor Ride

DIAGNOSIS

STEP 1. Check for excessive tire inflation pressure.

Refer to GROUP 31, On-vehicle Service –Tire Inflation Pressure Check P.31-7.

Q: Is the tire inflation pressure correct?

YES : Go to Step 2.

NO : Adjust the pressure, and then go to Step 4.

STEP 2. Check the condition of the shock absorbers (weak or broken springs).

Q: Are the shock absorbers in good condition?

YES : Go to Step 3.

NO : Replace the faulty part, and then go to Step 4.

STEP 3. Check the stabilizer bar and/or stabilizer bar links for deformity or damage.

Q: Are the stabilizer bar and/or stabilizer bar links deformed or damaged?

YES : Replace the faulty part, and then go to Step 4.

NO : Go to Step 4.

STEP 4. Retest the system.

Q: Is the malfunction eliminated?

YES : The procedure is complete.

NO : Return to Step 1.

INSPECTION PROCEDURE 3: Body Tilting

DIAGNOSIS

STEP 1. Check for weak or deteriorated bushings.

Q: Are the bushings in good condition?

YES : Go to Step 2.

NO : Replace the faulty part, and then go to Step 5.

STEP 2. Check for weak or broken coil springs.

Q: Are the coil springs in good condition?

YES : Go to Step 3.

NO : Replace the faulty part, and then go to Step 5.

STEP 3. Check the upper arms and/or lower arms and/or control links for deformity or damage.

Q: Are the upper arms and/or lower arms and/or control links deformed or damaged?

YES : Replace the faulty part, and then go to Step 5.

NO : Go to Step 4.

STEP 4. Check the trailing arms for deformity or damage.

Q: Are the trailing arms deformed or damaged?

YES : Replace the faulty part, and then go to Step 5.

NO : Go to Step 5.

STEP 5. Retest the system.

Q: Is the malfunction eliminated?

YES : The procedure is complete.

NO : Return to Step 1.

SPECIAL TOOLS

M1341000600820

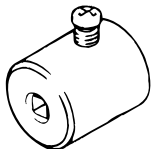
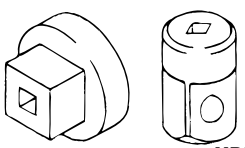
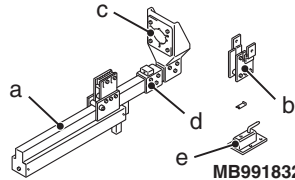
Tool	Tool number and name	Supersession	Application
 <p>MB991004</p>	MB991004 Wheel alignment gauge attachment	MB991004-01 or General service tool	Wheel alignment measurement
 <p>MB991006</p>	MB991006 Preload socket	MB990228-01	Upper arm ball joint rotation starting torque measurement
 <p>MB990326</p>	MB990326 Preload socket	General service tool	<ul style="list-style-type: none"> • Control link ball joint rotation starting torque measurement • Control link slide bushing rotation starting torque measurement • Lower arm pillow ball bushing rotation starting torque measurement • Trailing arm ball joint rotation starting torque measurement • Trailing arm pillow ball bushing rotation torque measurement • Upper arm pillow ball bushing rotation torque measurement • Stabilizer link ball joint rotation torque measurement
 <p>MB991832</p>	MB991832 a: MB991793 b: MB991796 c: MB991794 d: MB991829 e: MB991830 Spring compressor set a: Spring compressor b: Attachment c: Upper plate d: Arm bracket e: Fixture	General service tool	Rear coil spring compression

ON-VEHICLE SERVICE

REAR WHEEL ALIGNMENT CHECK AND ADJUSTMENT

M1341011000963

1. Before the wheel alignment measurement, adjust the rear suspension, wheel, and tires in good condition.
2. Park the vehicle on a level surface to measure the wheel alignment.

CAMBER

Standard value: $-1^{\circ} 00' \pm 0^{\circ} 30'$ (difference between left and right within $0^{\circ} 30'$)

Tighten the wheel alignment gauge attachment (Special tool: MB991004) to the specified torque, then measure the camber.

Tightening torque: 144 –176 N· m (107 –129 ft-lb)

If camber is not within the standard value, adjust by following procedures.

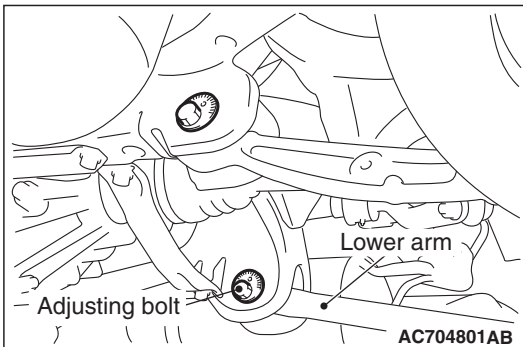
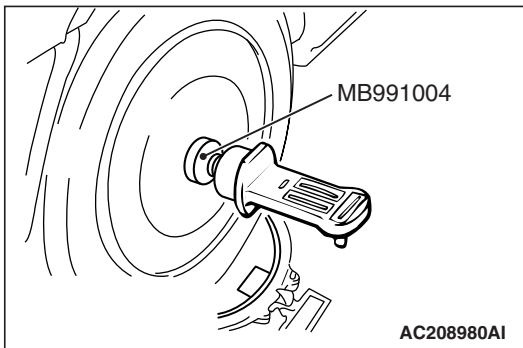

1. Turn the lower arm adjusting bolt (camber adjusting bolt) to adjust.

Left wheel: Turning clockwise $\rightarrow(+)$ camber

Right wheel: Turning clockwise $\rightarrow(-)$ camber

2. After adjusting the camber, the toe should be adjusted.

TOE-IN

Standard value: 3 ± 2 mm (0.12 ± 0.08 inch)

If toe-in is not within the standard value, adjust by following procedures.

1. Be sure to adjust the camber before making toe adjustment. Turn the adjusting bolt (toe adjusting bolt: control link mounting bolt which is located on the inner side of the body) to adjust.

Left wheel: Turning clockwise $\rightarrow(+)$ toe-in

Right wheel: Turning clockwise $\rightarrow(-)$ toe-in

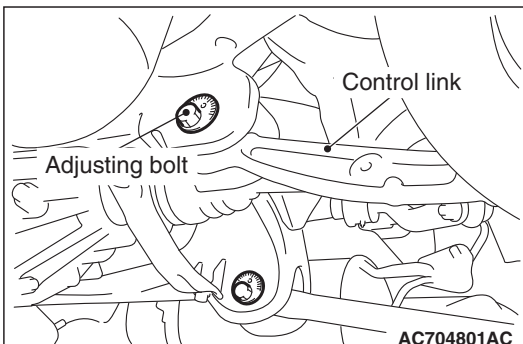

BALL JOINT DUST COVER INSPECTION

M1341012800393

**CONTROL LINK BALL JOINT DUST COVER
INSPECTION**** CAUTION**

Do not damage the control link ball joint dust cover during maintenance.

1. Using your fingers, press the dust cover to check for a crack or damage.
2. If the dust cover has a crack or damage, replace the control link. (Refer to [P.33-15.](#))

NOTE: If the dust cover has a crack or damage, the ball joint could be damaged.

If the dust cover is damaged during maintenance, replace the dust cover. (Refer to [P.33-16.](#))

**TRAILING ARM BALL JOINT DUST COVER
INSPECTION**** CAUTION**

Do not damage the trailing arm ball joint dust cover during maintenance.

1. Using your fingers, press the dust cover to check for a crack or damage.
2. If the dust cover has a crack or damage, replace the trailing arm. (Refer to [P.33-15.](#))

NOTE: If the dust cover has a crack or damage, the ball joint could be damaged.

If the dust cover is damaged during maintenance, replace the dust cover. (Refer to [P.33-16.](#))

UPPER ARM BALL JOINT DUST COVER INSPECTION

 **CAUTION**

Do not damage the upper arm ball joint dust cover during maintenance.

1. Using your fingers, press the dust cover to check for a crack or damage.
2. If the dust cover has a crack or damage, replace the upper arm. (Refer to [P.33-15.](#))

NOTE: If the dust cover has a crack or damage, the ball joint could be damaged.

If the dust cover is damaged during maintenance, replace the dust cover. (Refer to [P.33-16.](#))

STABILIZER LINK BALL JOINT DUST COVER INSPECTION

1. Using your fingers, press the dust cover to check for a crack or damage.
2. If the dust cover has a crack or damage, replace the stabilizer link. (Refer to [P.33-17.](#))

NOTE: If the dust cover has a crack or damage, the ball joint could be damaged.

If the dust cover is damaged during maintenance, replace the stabilizer link. (Refer to [P.33-17.](#))

CONTROL LINK AND LOWER ARM

REMOVAL AND INSTALLATION

M1341020000013

CAUTION

- Do not damage the control link ball joint dust cover and the trailing arm ball joint dust cover during maintenance. If they are damaged, replace the control link ball joint dust cover and trailing arm ball joint dust cover (P.34-16, P.34-20).
- The part indicated by *¹ should be temporarily tightened, and then fully tightened with the vehicle standing on the ground at the curb weight condition.
- The parts indicated by *² are the nuts with friction coefficient stabilizer. In removal, ensure there is no damage, clean dust and soiling from the bearing and thread surfaces, and tighten them to the specified torque.

Post-installation operation

- Using your fingers, press the Ball Joint Dust Cover to check for a crack or damage.
- Wheel alignment check and adjustment (Refer to P.34-16.)

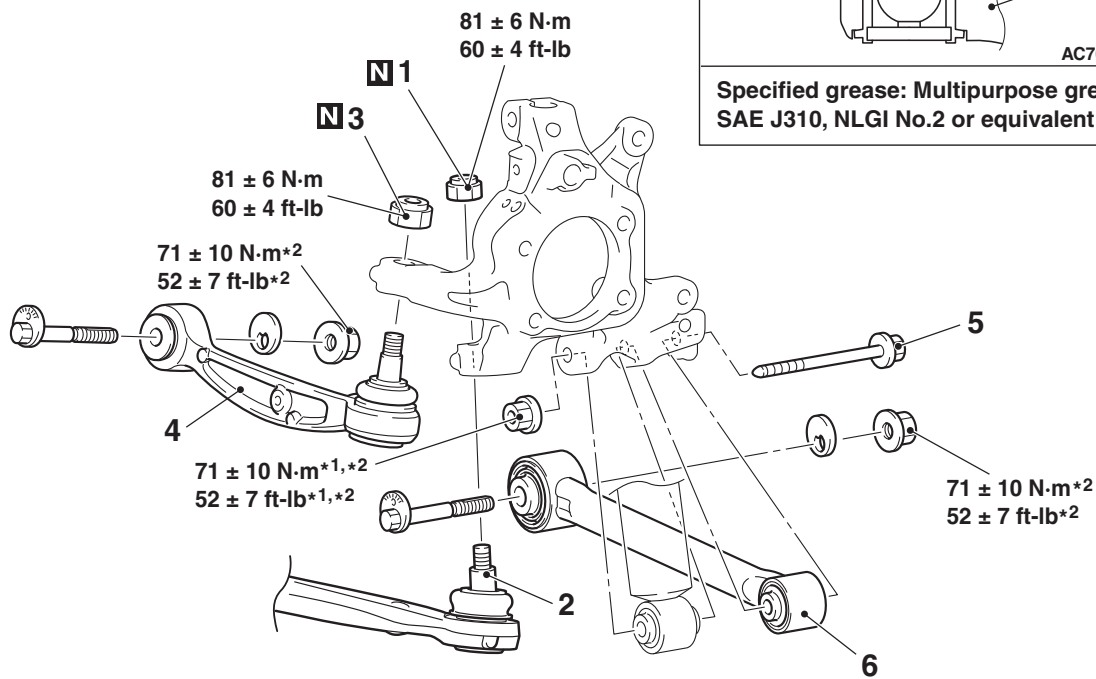

AC706763AB

- Control link removal**
- <<A>> >>A<< 1. Self-locking nut
2. Trailing arm and knuckle connection
- <<A>> >>A<< 3. Self-locking nut
<> 4. Control link assembly

<>

- Lower arm removal steps**
5. Knuckle, lower arm and shock absorber connection bolt
6. Lower arm assembly

Required Special Tool:

- MB991897 or MB992011: Ball Joint Remover

REMOVAL SERVICE POINTS

<<A>> SELF-LOCKING NUT REMOVAL

⚠ CAUTION

- Loosen the self-locking nut from the ball joint, but do not remove here. Use the special tool.
- To prevent the special tool from dropping off, suspend it with a cord.

1. Install special tool MB991897 or MB992011 as shown in the figure.

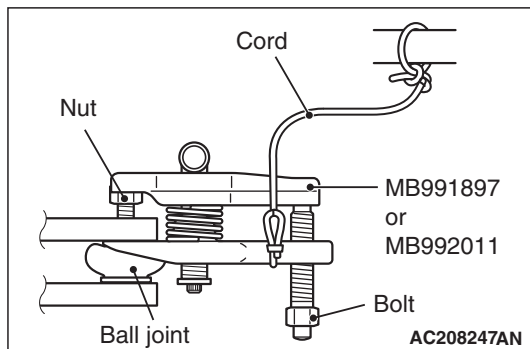

2. Turn the bolt and knob to make the special tool jaws parallel, then hand-tighten the bolt. After tightening, check that the jaws are still parallel.

NOTE: To adjust the special tool jaws to be parallel, set the orientation of the knob as shown in the figure.

3. Tighten the bolt with a wrench to disconnect the ball joint connection.

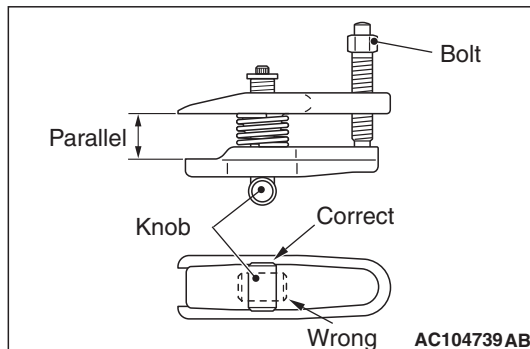

<> CONTROL LINK ASSEMBLY/LOWER ARM ASSEMBLY REMOVAL

Make mating marks on the adjusting bolts, and remove the control link assembly and lower arm assembly.

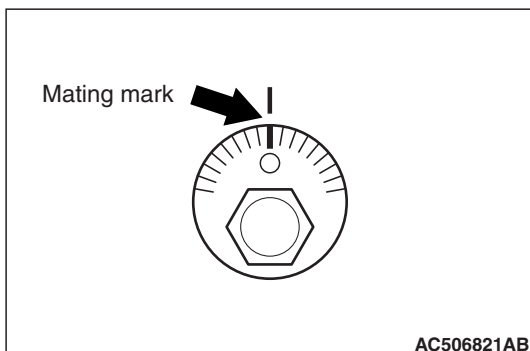

INSTALLATION SERVICE POINT

>>A<< SELF-LOCKING NUT INSTALLATION

1. Using a transmission jack and wooden block as shown in the figure, raise the control link assembly or trailing arm assembly.
2. Install the self-locking nut and tighten it to the specified torque.

Tightening torque: $81 \pm 6 \text{ N} \cdot \text{m}$ ($60 \pm 4 \text{ ft-lb}$)

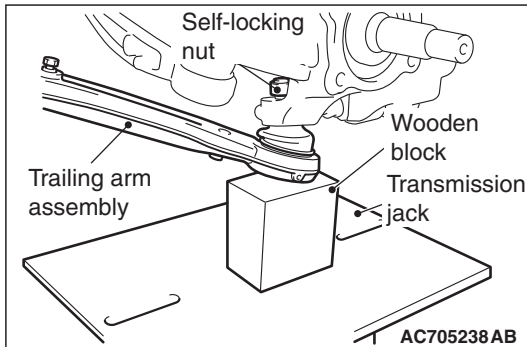
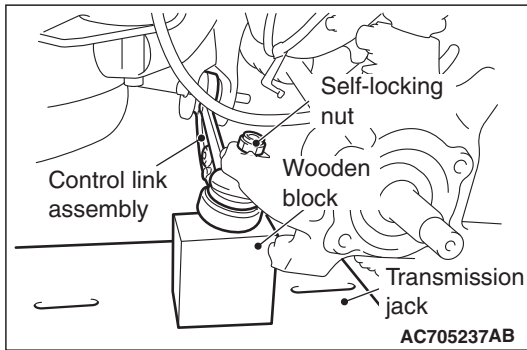

CONTROL LINK BALL JOINT ROTATION STARTING TORQUE CHECK

M1341021100013

Required Special Tool:

- MB990326: Preload socket

1. After moving the control link ball joint stud back and forth for several times, install the nut to the stud. Then, measure the control link ball joint rotation starting torque using the special tool MB990326.

Standard value: $0.5 - 2.5 \text{ N} \cdot \text{m}$ ($4.5 - 22.1 \text{ in-lb}$)

2. When the measured value exceeds the standard range, replace the control link assembly.
3. When the measured value is less than the standard value, check that the control link ball joint has no looseness or gritty feeling. If there is no looseness or gritty feeling, it is judged as usable.

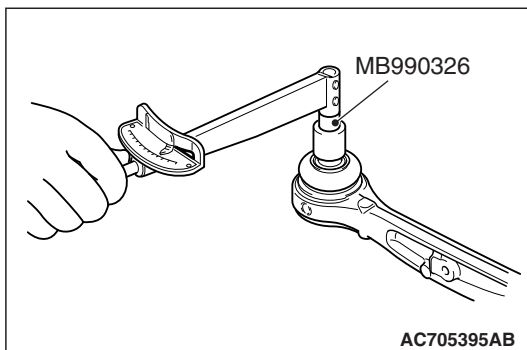

CONTROL LINK SLIDE BUSHING ROTATION STARTING TORQUE CHECK

M1341021200010

Required Special Tool:

- MB990326: Preload socket

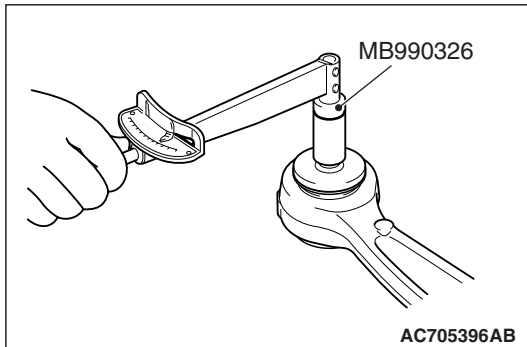

1. Insert the bolt to the control link slide bushing, and install the nuts with the washer from the opposite side. Rotate the inner cylinder (including washer) for several turns, and measure the rotation starting torque of the control link slide bushing using the special tool MB990326.

Standard value: 2.0 N·m (17.7 in-lb) or less

2. When the measured value exceeds the standard range, replace the control link assembly.
3. Even if the measured value is within the standard value, check that the control link slide bushing has no looseness or gritty feeling. If there is no looseness or gritty feeling, it is judged as usable.

CONTROL LINK BALL JOINT DUST COVER INSPECTION

M1341021300017

Refer to [P.34-10](#).

LOWER ARM PILLOW BALL BUSHING ROTATION STARTING TORQUE CHECK

M1341021400014

Required Special Tool:

- MB990326: Preload socket

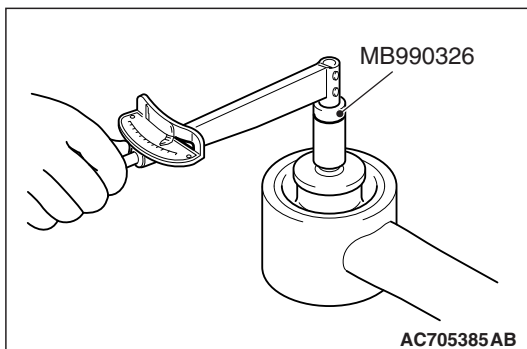

1. Insert the bolt to the lower arm pillow ball bushing, and install the nut with the washer from the opposite side. Rotate the inner cylinder (including washer) for several turns, and measure the rotation starting torque of the lower arm pillow ball bushing using the special tool MB990326.

Standard value:

Rear suspension crossmember side: 3.0 N·m (26.5 in-lb)

Knuckle side: 9.8 N·m (86.7 in-lb)

2. When the measured value exceeds the standard range, replace the lower arm assembly.
3. Even if the measured value is within the standard value, check that the lower arm pillow ball bushing has no looseness or gritty feeling. If there is no looseness or gritty feeling, it is judged as usable.

**CONTROL LINK BALL JOINT DUST COVER
REPLACEMENT**

M1341021500011

Required Special Tool:

- MB990800: Ball Joint Remover and Installer

Only when the control link ball joint dust cover is damaged accidentally during service work, replace the dust cover as follows:

1. Remove the control link ball joint dust cover.
2. Fill the specified grease in the control link ball joint dust cover and lubricate the lip.

**Specified grease: Multipurpose grease SAE J310,
NLGI No.2 or equivalent**

**Amount to use: Inside of control link ball joint dust
cover: Approx. 7g (0.247 ounce)**

Amount to use: lip part: as required

3. Using the special tool MB990800, punch the control link ball joint dust cover until it contacts the snap ring.
4. Press the control link ball joint dust cover with your finger to check that there are no cracks or damage in the dust cover.

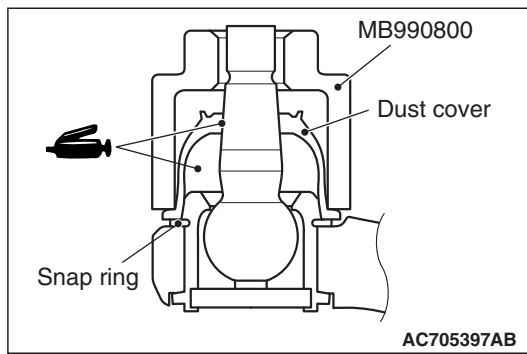

TRAILING ARM

REMOVAL AND INSTALLATION

M1341002200981

⚠ CAUTION

- Do not damage the trailing arm ball joint dust cover during maintenance. If it is damaged, replace the trailing arm ball joint dust cover (P.34-20).
- The part indicated by * is the bolt with friction coefficient stabilizer. In removal, ensure there is no damage, clean dust and soiling from the bearing and thread surfaces, and tighten them to the specified torque.

Post-installation operation

- Using your fingers, press the Ball Joint Dust Cover to check for a crack or damage.
- Wheel alignment check and adjustment (Refer to P.34-20.)

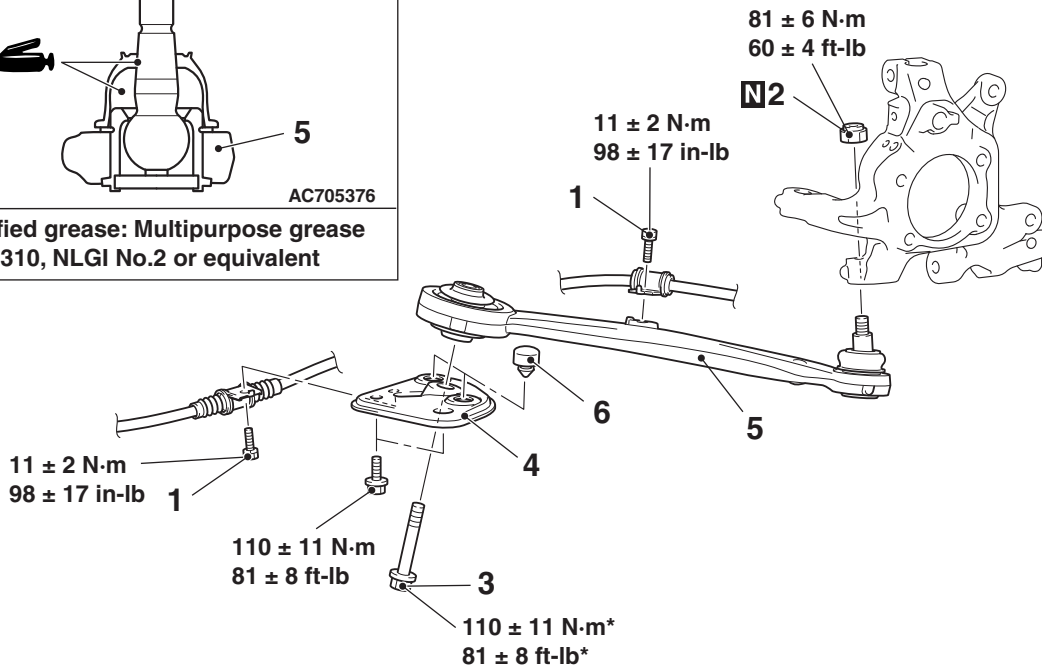
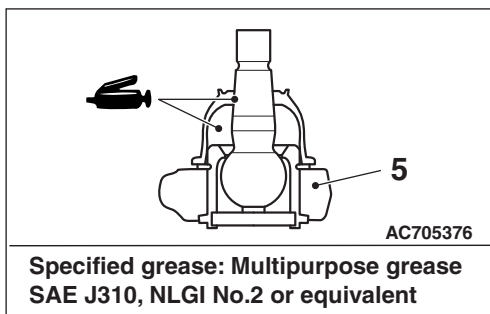

AC705374AB

Removal steps

- <<A>> >>A<<
1. Parking brake cable mounting bolt
 2. Self-locking nut
 3. Trailing arm assembly mounting bolt

Removal steps (Continued)

4. Trailing arm bracket assembly
5. Trailing arm assembly
6. Stopper

Required Special Tool:

- MB991897 or MB992011: Ball Joint Remover

REMOVAL SERVICE POINT

<<A>> SELF-LOCKING NUT REMOVAL

⚠ CAUTION

- Loosen the self-locking nut from the ball joint, but do not remove here. Use the special tool.
- To prevent the special tool from dropping off, suspend it with a cord.

1. Install special tool MB991897 or MB992011 as shown in the figure.

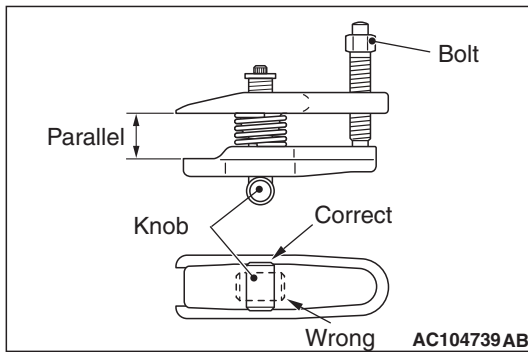
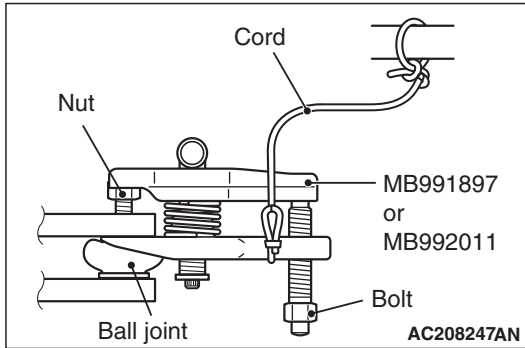

2. Turn the bolt and knob to make the special tool jaws parallel, then hand-tighten the bolt. After tightening, check that the jaws are still parallel.

NOTE: To adjust the special tool jaws to be parallel, set the orientation of the knob as shown in the figure.

3. Tighten the bolt with a wrench to disconnect the ball joint connection.

INSTALLATION SERVICE POINT

>>A<< SELF-LOCKING NUT INSTALLATION

1. Using a transmission jack and wooden block as shown in the figure, raise the trailing arm assembly.
2. Install the self-locking nut and tighten it to the specified torque.

Tightening torque: 81 ± 6 N·m (60 ± 4 ft-lb)

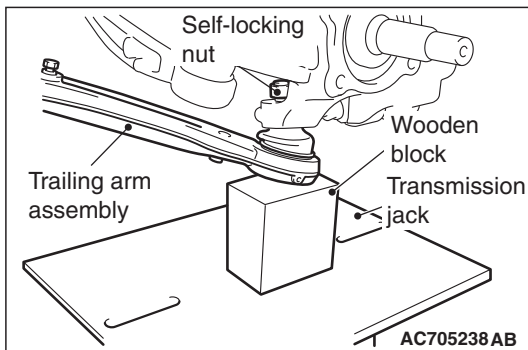

TRAILING ARM BALL JOINT ROTATION STARTING TORQUE CHECK

M1341021900019

Required Special Tool:

- MB990326: Preload socket

1. After moving the trailing arm ball joint stud back and forth for several times, install the nut to the stud. Then, measure the trailing arm ball joint rotation starting torque using the special tool MB990326.

Standard value: 0.5 –2.5 N· m (4.5 –22.1 in-lb)

2. When the measured value exceeds the standard range, replace the trailing arm assembly.
3. When the measured value is less than the standard value, check that the trailing arm ball joint has no looseness or gritty feeling. If there is no looseness or gritty feeling, it is judged as usable.

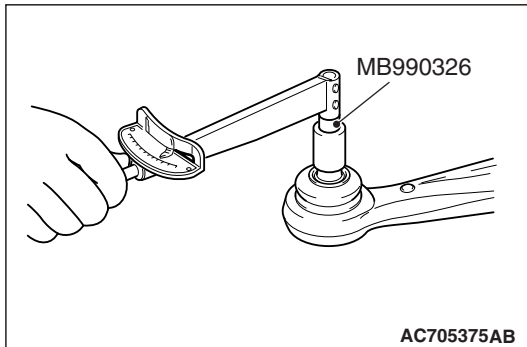

TRAILING ARM BALL JOINT DUST COVER INSPECTION

M1341022100016

Refer to [P.34-10](#).

TRAILING ARM PILLOW BALL BUSHING ROTATION TORQUE CHECK

M1341022000019

Required Special Tool:

- MB990326: Preload socket

1. Insert the bolt to the trailing arm pillow ball bushing, and install the nut with the washer from the opposite side. Rotate the inner cylinder (including washer) for several turns, and measure the rotation starting torque of the trailing arm pillow ball bushing using the special tool MB990326.

Standard value: 1.5 N· m (13.2 in-lb) or less

2. When the measured value exceeds the standard range, replace the trailing arm assembly.
3. Even if the measured value is within the standard value, check that the trailing arm pillow ball bushing has no looseness or gritty feeling. If there is no looseness or gritty feeling, it is judged as usable.

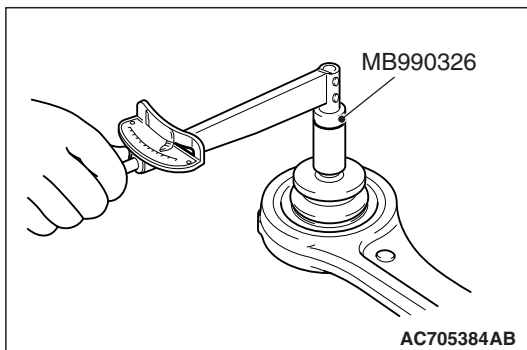

**TRAILING ARM BALL JOINT DUST COVER
REPLACEMENT**

M1341022200013

Required Special Tool:

- MB990800: Ball Joint Remover and Installer

Only when the trailing arm ball joint dust cover is damaged accidentally during service work, replace the dust cover as follows:

1. Remove the trailing arm ball joint dust cover.
2. Fill the specified grease in the trailing arm ball joint dust cover and lubricate the lip.

**Specified grease: Multipurpose grease SAE J310,
NLGI No.2 or equivalent**

**Amount to use: Inside of trailing arm ball joint dust
cover: Approx. 7g (0.247 ounce)**

Amount to use: lip part: as required

3. Using the special tool MB990800, punch the trailing arm ball joint dust cover until it contacts the snap ring.
4. Press the trailing arm ball joint dust cover with your finger to check that there are no cracks or damage in the dust cover.

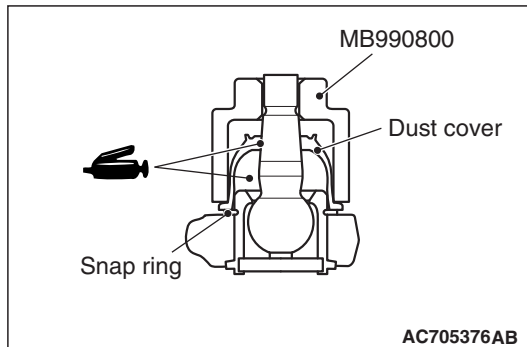

UPPER ARM ASSEMBLY

REMOVAL AND INSTALLATION

M1341003600379

CAUTION

- Do not damage the upper arm ball joint dust cover during maintenance. If it is damaged, replace the upper arm ball joint dust cover (P.34-23).
- The part indicated by *¹ should be temporarily tightened, and then fully tightened with the vehicle standing on the ground and the curb weight condition.
- The parts indicated by *² are the bolts and nut with friction coefficient stabilizer. In removal, ensure there is no damage, clean dust and soiling from the bearing and thread surfaces, and tighten them to the specified torque.

Pre-removal operation

- Fuel Filler Neck Removal (Refer to GROUP 13B, Fuel Tank P.13B-10.) (LH only)

Post-installation operation

- Check the ball joint dust cover for cracks or damage by pushing it with your finger.
- Fuel Filler Neck Installation (Refer to GROUP 13B, Fuel Tank P.13B-10.) (LH only)
- Wheel Alignment Check and Adjustment (Refer to P.34-9 .)

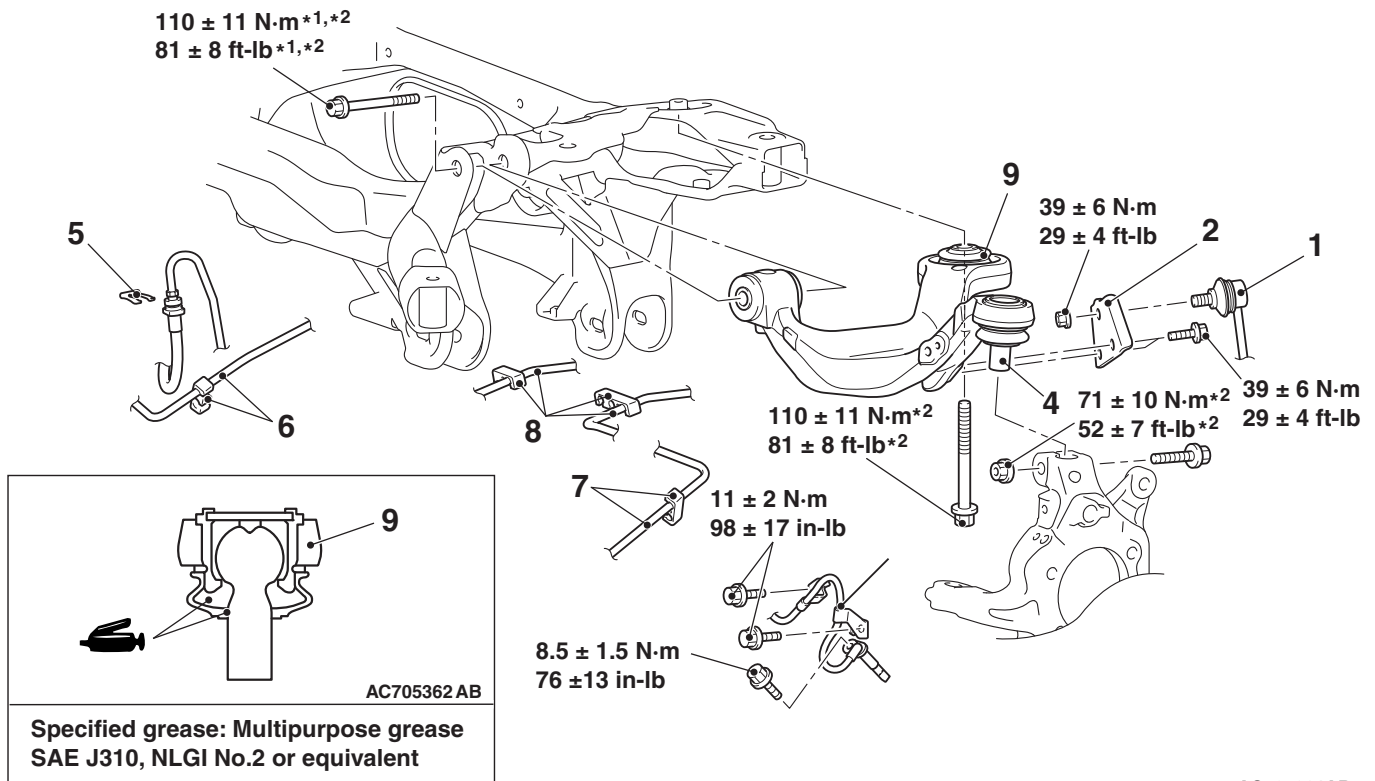

Removal steps

1. Stabilizer link and stabilizer bracket connection
2. Stabilizer bracket
3. Rear wheel speed sensor
4. Upper arm and knuckle connection
5. Brake hose clip (RH side) (RH only)

Removal steps (Continued)

6. Brake tube (RH side) and clip connection (RH only)
7. Brake tube (LH side) and clip connection (LH only)
8. Brake tube (Center side) and clip connection (LH only)
9. Upper arm assembly

UPPER ARM BALL JOINT ROTATION STARTING
TORQUE CHECK

M1341021600018

Required Special Tool:

- MB991006: Preload socket

1. Move the upper arm ball joint stud back and forth for several times, then measure the upper arm ball joint rotation starting torque using the special tool MB991006.

Standard value: 3.4 N·m (30.0 in-lb) or less

2. When the measured value exceeds the standard range, replace the upper arm assembly.
3. Even if the measured value is within the standard value, check that the upper arm ball joint has no looseness or gritty feeling. If there is no looseness or gritty feeling, it is judged as usable.

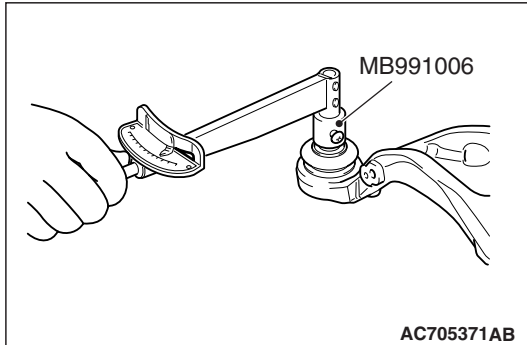
UPPER ARM BALL JOINT DUST COVER
INSPECTION

M1341019700029

Refer to [P.34-10](#).

UPPER ARM PILLOW BALL BUSHING ROTATION
TORQUE CHECK

M1341021700015

Required Special Tool:

- MB990326: Preload socket

1. Insert the bolt to the upper arm pillow ball bushing, and install the nut with the washer from the opposite side. Rotate the inner cylinder (including washer) for several turns, and measure the rotation starting torque of the upper arm pillow ball bushing using the special tool MB990326.

Standard value: 1.5 N·m (13.2 in-lb) or less

2. When the measured value exceeds the standard range, replace the upper arm assembly.
3. Even if the measured value is within the standard value, check that the upper arm pillow ball bushing has no looseness or gritty feeling. If there is no looseness or gritty feeling, it is judged as usable.

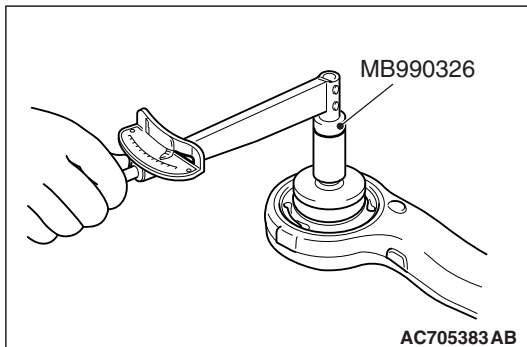

UPPER ARM BALL JOINT DUST COVER REPLACEMENT

M1341021800012

Required Special Tool:

MB990800: Ball Joint Remover and Installer

Only when the upper arm ball joint dust cover is damaged accidentally during service work, replace the dust cover as follows:

1. Remove the upper arm ball joint dust cover.
2. Fill the specified grease in the upper arm ball joint dust cover and lubricate the lip.

Specified grease: Multipurpose grease SAE J310, NLGI No.2 or equivalent

Amount to use: Inside of upper arm ball joint dust cover: 9.0 –10.0 g (0.32 –0.35 ounce)

Amount to use: lip part: as required

3. Using the special tool MB990800, punch the upper arm ball joint dust cover until it contacts the snap ring.
4. Press the upper arm ball joint dust cover with your finger to check that there are no cracks or damage in the dust cover.

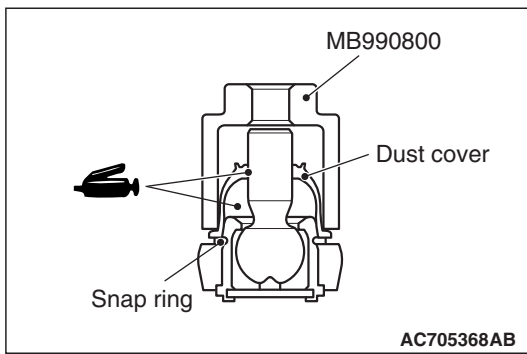

SHOCK ABSORBER ASSEMBLY

REMOVAL AND INSTALLATION

M1341002500681

CAUTION

- The part indicated by *1 should be temporarily tightened, and then fully tightened with the vehicle standing on the ground and the curb weight condition.
- The part indicated by *2 is the nut and nut with friction coefficient stabilizer. In removal, ensure there is no damage, clean dust and soiling from the bearing and thread surfaces, and tighten them to the specified torque.

Pre-removal and post-installation operation

- Trunk Room Trim Front Removal and Installation (Refer to GROUP 52A, Trim P.52A-12.)

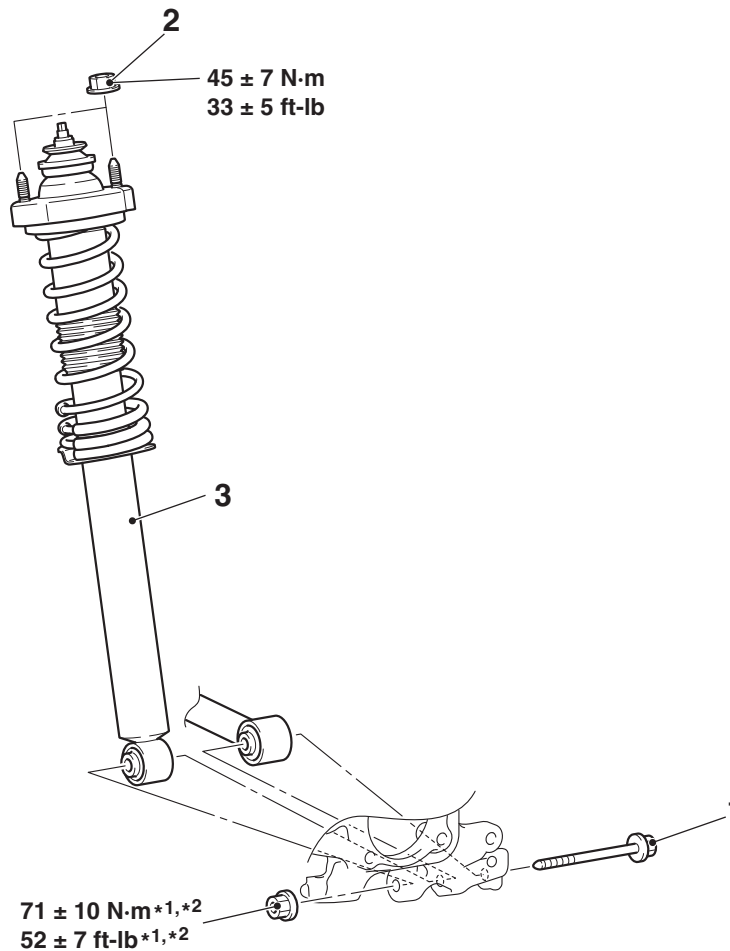

AC705404 AB

Removal steps

1. Knuckle, lower arm and shock absorber connecting bolt

Removal steps (Continued)

2. Shock absorber mounting nut
3. Shock absorber assembly

INSTALLATION SERVICE POINT

>>A<< SHOCK ABSORBER ASSEMBLY INSTALLATION

Install the shock absorber assembly so that the coil spring end faces the rear of the vehicle.

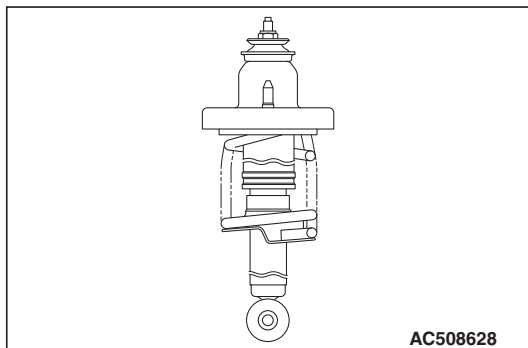

DISASSEMBLY AND ASSEMBLY

M1341002700254

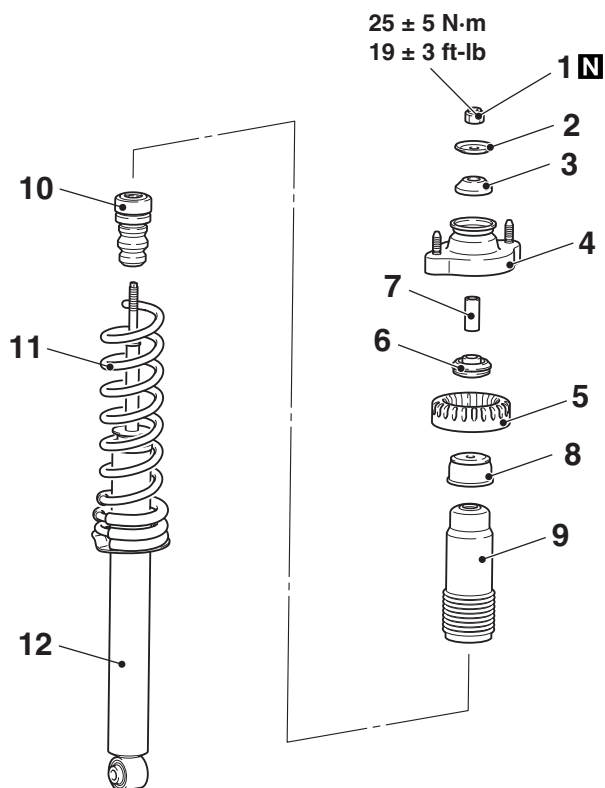

AC705405 AB

- <<A>> >>B<<
- Disassembly steps**
1. Self-locking nut
 2. Washer
 3. Bushing B
 4. Insulator
 5. Spring upper pad
 6. Bushing C
 7. Collar
 8. Cup
 9. Cover
 10. Damper

- >>A<< <>
- Disassembly steps (Continued)**
11. Coil spring
 12. Shock absorber

Required Special Tools:

- MB991793: Spring compressor
- MB991796: Attachment B
- MB991794: Upper plate
- MB991830: Fixture

DISASSEMBLY SERVICE POINTS

<<A>> SELF-LOCKING NUT REMOVAL

⚠ CAUTION

The locking nut for the piston rod inside the shock absorber may be loose. Do not use an impact wrench to loosen the self-locking nut.

1. Install the special tool MB991796 to the special tool MB991793 as shown in the figure.

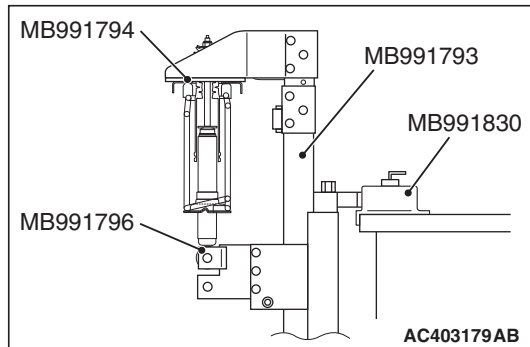
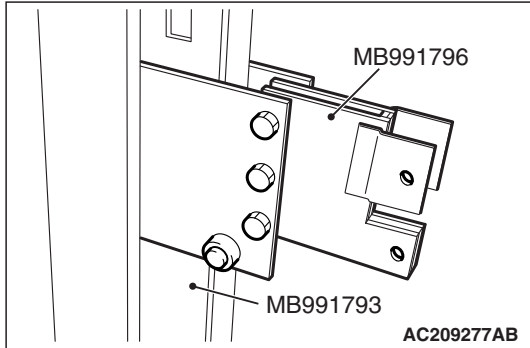

2. Set the strut assembly to special tools: MB991793, MB991796, MB991794 and MB991830.

NOTE: Use the bolts and nuts removed from the vehicle to secure the shock absorber assembly and tighten them lightly by hand.

3. After setting the shock absorber assembly, operate the spring compressor and compress the coil spring by approximately 5 mm (0.20 in).

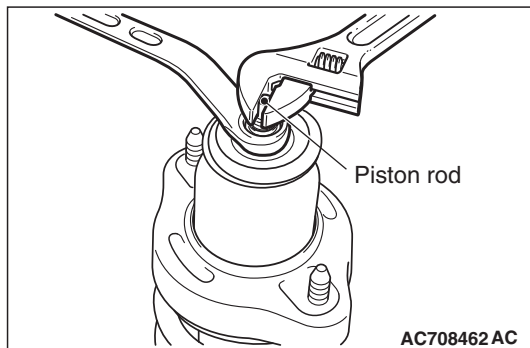

4. While holding the piston rod as shown in the figure, remove the self-locking nut.

<> SHOCK ABSORBER DISPOSAL PROCEDURES

CAUTION

Wear the protective glasses. Although the gas is harmless, drilling chips may be blown out by the gas.

Before disposal of the shock absorber, place the shock absorber on the level surface with the piston rod extended, and make a hole of approximately 3 mm (0.12 in) in diameter at the point shown in the figure to discharge the gas.

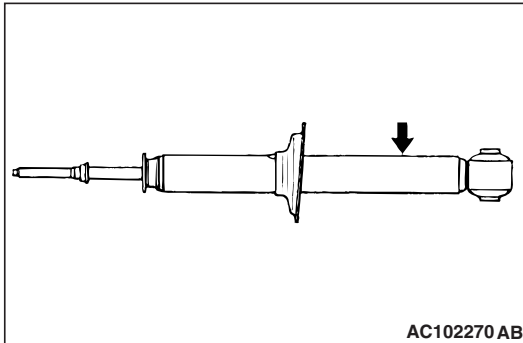

ASSEMBLY SERVICE POINTS

>>A<< COIL SPRING INSTALLATION

1. Install the coil spring end as shown in the figure, so that it should face the vehicle rearward.

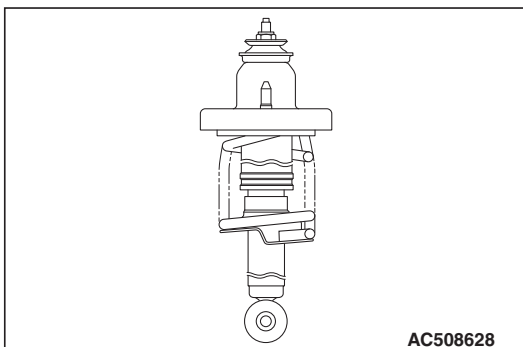

2. Set the shock absorber to special tools: MB991793, MB991796, MB991794 and MB991830, and slowly compress the coil spring while guiding the shock absorber piston rod through the hole on the upper spring bracket by hand:

NOTE: Use the bolts and nuts removed from the vehicle to secure the shock absorber assembly and tighten them lightly by hand.

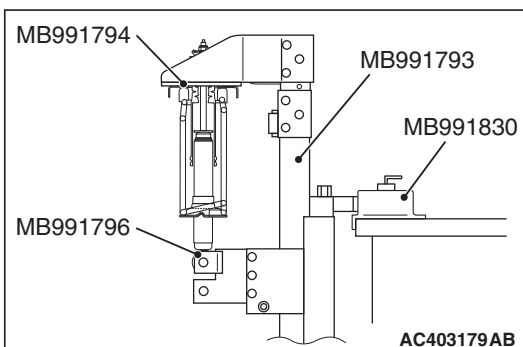

>>B<< SELF-LOCKING NUT INSTALLATION

CAUTION

The locking nut for the piston rod inside the shock absorber may be loose. Do not use an impact wrench to tighten the self-locking nut.

Counter the piston rod of the shock absorber as shown in the figure, and tighten the self-locking nut to the specified torque.

Tightening torque: 25 ± 5 N·m (19 ± 3 ft-lb)

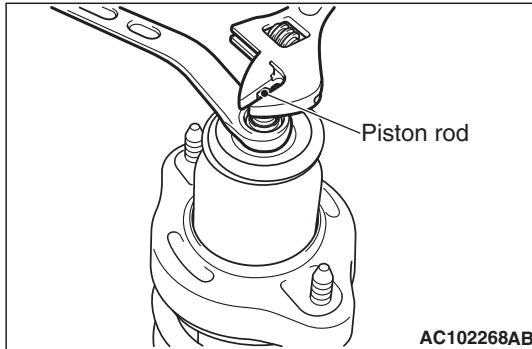

STABILIZER BAR

REMOVAL AND INSTALLATION

M1341003000593

Post-installation operation

- Check the ball joint dust cover for cracks or damage by pushing it with your finger.

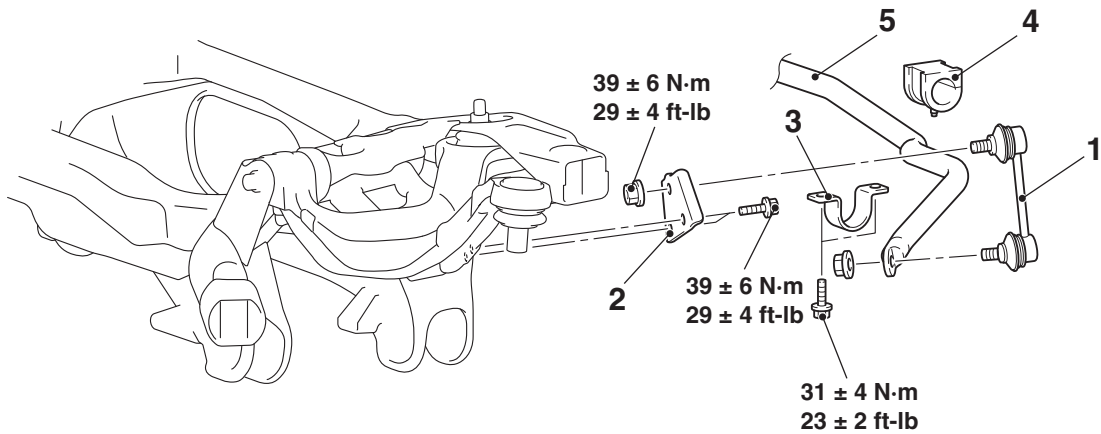

Removal steps

- >>A<<
1. Stabilizer link
 2. Stabilizer bracket
 3. Stabilizer clamp

Removal steps (Continued)

- >>A<<
4. Bushing
 5. Stabilizer bar

INSTALLATION SERVICE POINT

>>A<< STABILIZER BAR/BUSHING/STABILIZER CLAMP INSTALLATION

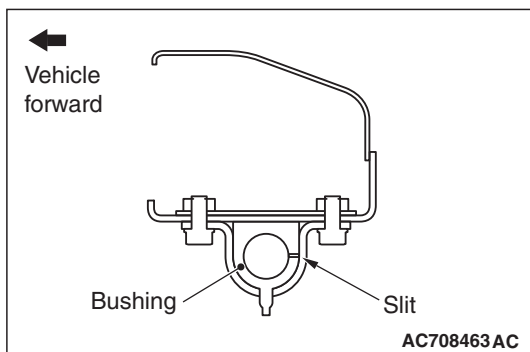
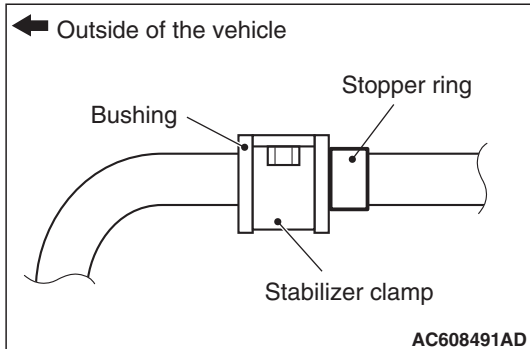

1. Install the stabilizer clamp at the position shown in the figure, and tighten the stabilizer clamp mounting bolt.

2. Install the bushing with the bushing slit directed toward the rear of the vehicle.

STABILIZER LINK CHECK

M1341019800026

STABILIZER LINK BALL JOINT ROTATION TORQUE CHECK

Required Special Tool:

- MB990326: Preload socket

1. Move the stabilizer link ball joint stud back and forth for several times, install the stud with nut, and measure the stabilizer link ball joint rotation torque using special tool MB990326.

Standard value:

10 –30° C (50 –86° F): 0.2 –2.0 N· m (1.8 –17.7 in-lb)

Other than 10 –30° C (50 –86° F): 0.2 –5.0 N· m (1.8 –44.2 in-lb)

2. When the measured value exceeds the standard range, replace the stabilizer link assembly. (Refer to [P.34-28.](#))
3. Even if the measured value is within the standard value, check that the stabilizer link ball joint has no looseness or gritty feeling. If there is no looseness or gritty feeling, it is judged as usable.

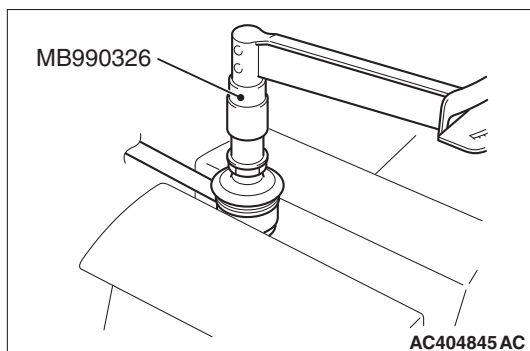

STABILIZER LINK BALL JOINT DUST COVER INSPECTION

Refer to [P.34-10.](#)

REAR SUSPENSION CROSSMEMBER

REMOVAL AND INSTALLATION

M1341006800628

CAUTION

- The parts indicated by *¹ should be temporarily tightened, and then fully tightened with the vehicle standing on the ground and the curb weight condition.
- The parts indicated by *² are the bolts with friction coefficient stabilizer. In removal, ensure there is no damage, clean dust and soiling from the bearing and thread surfaces, and tighten them to the specified torque.

Pre-removal operation

- Exhaust pipe and main muffler removal (Refer to GROUP 15 –Exhaust Pipe and Muffler P.15-26.)
- Control link removal (Refer to P.34-12.)
- Lower arm removal (Refer to P.34-12.)
- Rear suspension stabilizer bar removal (Refer to P.34-28.)
- Knuckle removal (Refer to GROUP 27, Knuckle P.27-39.)
- Driveshaft removal (Refer to GROUP 27, Driveshaft Assembly P.27-42.)
- Rear differential assembly removal (Refer to GROUP27, Differential Carrier Assembly P.27-51.)
- Fuel filler neck removal (Refer to GROUP 13B, Fuel Tank P.13B-10.) (LH only)

Post-installation operation

- Rear differential assembly installation (Refer to GROUP 27, Differential Carrier Assembly P.27-51.)
- Driveshaft installation (Refer to GROUP 27, Driveshaft Assembly P.27-42.)
- Knuckle installation (Refer to GROUP 27, Knuckle P.27-39.)
- Rear suspension stabilizer bar installation (Refer to P.34-28.)
- Lower arm installation (Refer to P.34-12.)
- Control link installation (Refer to P.34-12.)
- Exhaust pipe and main muffler installation (Refer to GROUP 15 –Exhaust Pipe and Muffler P.15-26.)
- Wheel Alignment Check and Adjustment (Refer to P.34-9.)
- Fuel filler neck installation (Refer to GROUP 13B, Fuel Tank P.13B-10.) (LH only)

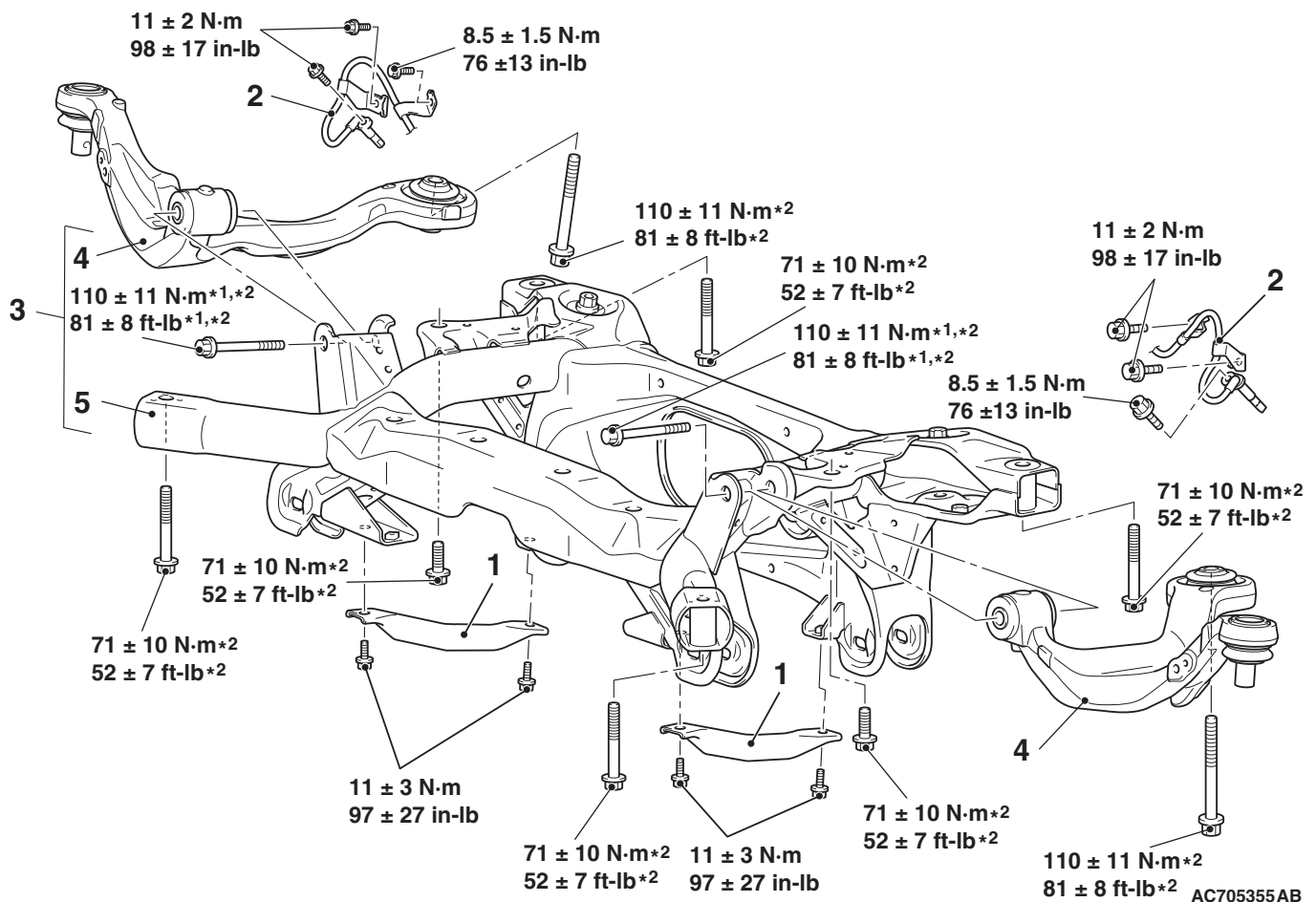

- Removal steps**
- >>A<< 1. Rear suspension crossmember stay
2. Rear wheel speed sensor

<<A>>

- Removal steps (Continued)**
3. Upper arm and rear suspension crossmember assembly
 4. Upper arm
 5. Rear suspension crossmember

REMOVAL SERVICE POINT

<<A>> REAR SUSPENSION CROSSMEMBER REMOVAL

Place a wooden block against the bottom of rear suspension crossmember front, and remove the crossmember. Do not tilt the crossmember during removal.

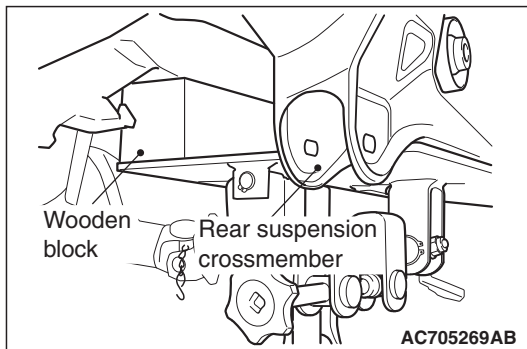

INSTALLATION SERVICE POINT

>>A<< REAR SUSPENSION CROSSMEMBER INSTALLATION

Install the rear suspension crossmember stay so that the water drain hole is positioned rearward.

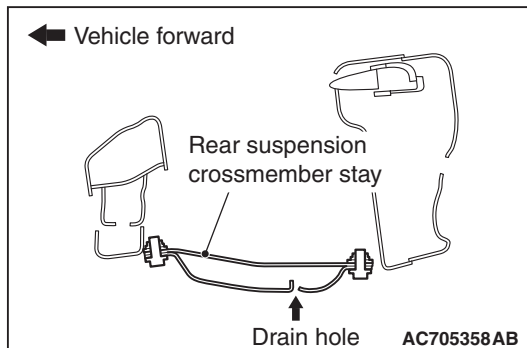

NOTES