

GROUP 35C

ACTIVE STABILITY CONTROL SYSTEM (ASC)

CONTENTS

GENERAL INFORMATION	35C-3	ACTUATOR TEST REFERENCE TABLE ..	35C-278
		CHECK AT ECU TERMINALS	35C-280
SERVICE SPECIFICATIONS	35C-6		
DIAGNOSIS	35C-6	SPECIAL TOOLS	35C-283
INTRODUCTION TO ASC DIAGNOSIS ..	35C-6	ON-VEHICLE SERVICE	35C-284
ASC DIAGNOSTIC TROUBLESHOOTING STRATEGY	35C-6	HYDRAULIC UNIT CHECK	35C-284
PRECAUTIONS FOR DIAGNOSIS	35C-7	IN THE EVENT OF A DISCHARGED BATTERY	35C-287
ABS WARNING LIGHT, ASC WARNING/ OPERATION LIGHT AND BRAKE WARNING LIGHT CHECK	35C-8	G AND YAW RATE SENSOR CALIBRATION	35C-287
DIAGNOSTIC FUNCTION	35C-8	STEERING WHEEL SENSOR CALIBRATION	35C-289
DIAGNOSTIC TROUBLE CODE CHART ..	35C-22	MASTER CYLINDER BRAKE FLUID PRESSURE SENSOR CALIBRATION	35C-294
DIAGNOSTIC TROUBLE CODE PROCEDURES	35C-25	CALIBRATION OF CUT VALVE AND INLET VALVE	35C-295
TROUBLE SYMPTOM CHART	35C-232		
SYMPTOM PROCEDURES	35C-233		
DATA LIST REFERENCE TABLE	35C-276		

Continued on next page

WARNINGS REGARDING SERVICING OF SUPPLEMENTAL RESTRAINT SYSTEM (SRS) EQUIPPED VEHICLES

⚠ WARNING

- *Improper service or maintenance of any component of the SRS, or any SRS-related component, can lead to personal injury or death to service personnel (from inadvertent firing of the air bag) or to the driver and passenger (from rendering the SRS inoperative).*
- *Service or maintenance of any SRS component or SRS-related component must be performed only at an authorized MITSUBISHI dealer.*
- *MITSUBISHI dealer personnel must thoroughly review this manual, and especially its GROUP 52B - Supplemental Restraint System (SRS) before beginning any service or maintenance of any component of the SRS or any SRS-related component.*

NOTE

The SRS includes the following components: SRS air bag control unit, SRS warning light, front impact sensors, air bag module, side-airbag module, curtain air bag module, side impact sensors, seat belt pre-tensioners, clock spring, and interconnecting wiring. Other SRS-related components (that may have to be removed/installed in connection with SRS service or maintenance) are indicated in the table of contents by an asterisk (*).

35C-2

ASC OFF SWITCH 35C-296

REMOVAL AND INSTALLATION 35C-296

INSPECTION 35C-297

HYDRAULIC UNIT 35C-298

REMOVAL AND INSTALLATION 35C-298

WHEEL SPEED SENSOR 35C-300

REMOVAL AND INSTALLATION 35C-300

INSPECTION 35C-303

G AND YAW RATE SENSOR 35C-304

REMOVAL AND INSTALLATION 35C-304

STEERING WHEEL SENSOR* 35C-305

REMOVAL AND INSTALLATION 35C-305

GENERAL INFORMATION

M1355000200278

Active stability control (ASC) has been equipped as a standard.

- ASC has been added to the transaxle <twin clutch sportronic shift transmission (TC-SST)^{*1}> control <vehicles for TC-SST> and AWD <super all wheel control (S-AWC)^{*2}> control, and the controls are integrated to improve the vehicle stability.
- The ASC system integrates the traction control (TCL) function and skid control function.
- When the TCL function detects the slip of driving wheel (for example, during startup on slippery road), it automatically applies the braking force to the slipping driving wheel. At the same time, TCL reduces the engine output and prevents the wheel spin when it determines that the engine torque is too high for the road surface friction coefficient.

- When the skid control function determines that the vehicle behavior is in a critical state, it reduces the engine output and applies brake force to four wheels independently to control the vehicle behavior, avoiding the critical state.
- Brake performance at ASC system failure is ensured by the fail-safe function, and at the same time, the serviceability during service is improved.

NOTE:

- ^{*1}: For the details on twin clutch sportronic shift transmission (TC-SST), refer to technical information manual.
- ^{*2}: For the details on super all wheel control (S-AWC), refer to technical information manual.
- The active stability control (ASC) has the traction control function and the skid control function. By the integrated control with the anti-lock brake system, the system stabilizes the vehicle attitude and, at the same time, secures the driving force.

CONSTRUCTION DIAGRAM

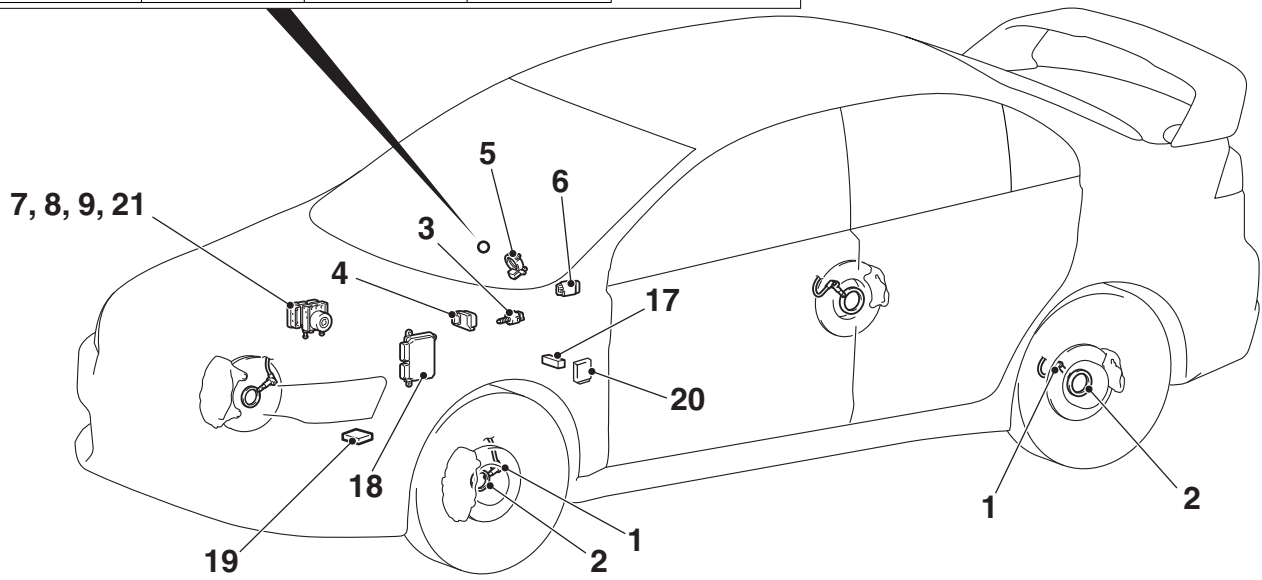
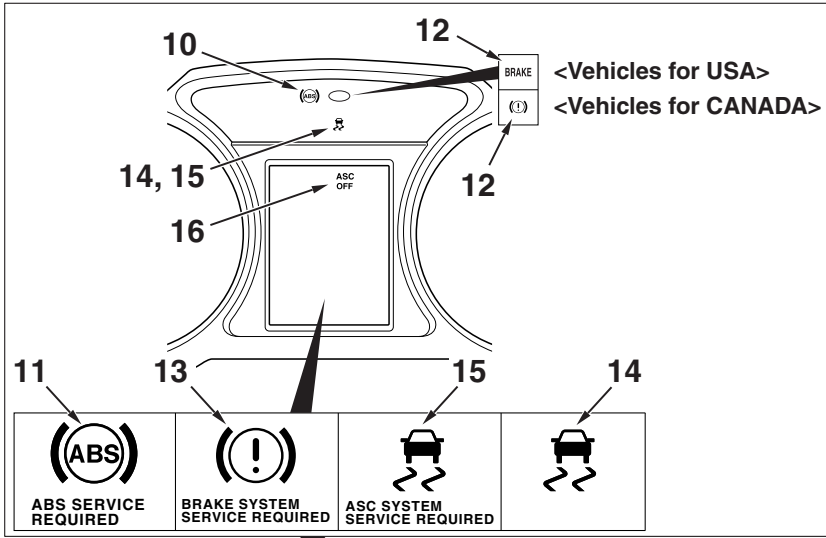

AC901871 AB

MAIN COMPONENTS AND FUNCTIONS

Parts name		No.	Functional description
Sensor	Wheel speed sensor	1	Outputs the frequency pulse signal in proportion to the rotation speed of each wheel to ASC-ECU.
	Magnetic encoder for wheel speed detection	2	When the magnetic encoder for wheel speed detection (a plate on which north and south pole sides of the magnets are arranged alternately) rotates, the wheel speed sensor outputs frequency pulse signal in proportion to each wheel speed.
	Stoplight switch	3	Outputs the signal indicating whether the brake pedal is depressed or not to ASC-ECU.
	G and yaw rate sensor	4	Detects the yaw rate, and longitudinal and lateral acceleration of a vehicle, then outputs the signal to ASC-ECU via the CAN line.
	Steering wheel sensor	5	Detects the steering angle of steering wheel, and outputs the signal to ASC-ECU via the CAN bus line.
	ASC OFF switch	6	Outputs the ASC ON/OFF signal to ASC-ECU.
	Master cylinder pressure sensor	7	Integrated into the hydraulic unit, converts the signal of brake fluid pressure in master cylinder to the voltage value, then outputs the value to ASC-ECU.
	Wheel cylinder pressure sensor	8	Integrated into the hydraulic unit, converts the signal of brake fluid pressure in wheel cylinder of each wheel to the voltage value, then outputs the value to ASC-ECU.
Actuator	Hydraulic unit	9	Drives the solenoid valve using the signal from ASC-ECU, and controls the brake fluid pressure for each wheel.
	ABS warning light	10	Informs the driver of the system status by illuminating, flashing, or turning off the warning light according to the signal from ASC-ECU.
	ABS warning display	11	Informs the driver of the system status by illuminating or turning off the warning light according to the signal from ASC-ECU.
	Brake warning light	12	Used as the warning light for the parking brake, brake fluid level, and EBD control. Informs the driver of the system status by illuminating or turning off the warning light according to the signal from ASC-ECU.
	Brake warning display	13	Used as the warning light for the brake fluid level and EBD control. Informs the driver of the system status by illuminating or turning off the brake warning display according to the signal from ASC-ECU.
	ASC operation display and light	14	According to the signal from ASC-ECU, flashes when the system is active to inform the driver of the status.
	ASC warning display and light	15	The TCL function and skid control function use the same display. According to the signal from ASC-ECU, the display is illuminated to inform the driver that the system is abnormal.
	ASC OFF display	16	Informs the driver of the ASC system shutdown by illuminating according to the signal from ASC-ECU.

Parts name	No.	Functional description
Data link connector	17	Outputs the diagnostic trouble code and establishes the communication with the scan tool.
Engine Control Module (ECM)	18	Controls the engine output based on the signal from ASC-ECU.
TC-SST ECU*	19*	Outputs the shift position to ASC-ECU.
AWC ECU	20	Outputs the drive status and brake fluid pressure request to ASC-ECU.
ASC-ECU	21	Controls the actuators (described above) based on the signals coming from each sensors.
		Controls the self-diagnostic functions and fail-safe functions.
		Controls diagnostic function (Compatible with scan tool).

NOTE: *: Only for vehicles with TC-SST

SERVICE SPECIFICATIONS

M1355008200108

Item	Standard value
Wheel speed sensor current mA	5.9 –8.4 or 11.8 –16.8
Wheel speed sensor insulation resistance MΩ	5 or more

DIAGNOSIS

INTRODUCTION TO ASC DIAGNOSIS

The active stability control system (ASC) operates differently from conventional brake systems. These differences include sounds, sensations, and vehicle performance that owners and service technicians who are not familiar with ASC may not be used to.

ASC DIAGNOSTIC TROUBLE CODE DETECTION CONDITIONS

ASC diagnostic trouble codes (ASC DTCs) are set under different conditions, depending on the malfunction detected. Most ASC DTCs will only be set during vehicle operation. Some ASC DTCs will also be set during the ASC self-check immediately after the engine is started.

ASC DIAGNOSTIC TROUBLESHOOTING STRATEGY

Use these steps to plan your diagnostic strategy. If you follow them carefully, you will be sure that you have exhausted most of the possible ways to find an ASC fault.

Some operational characteristics may seem to be malfunctions, but they are simply signs of normal ASC operation. When diagnosing the ASC system, keep these operational characteristics in mind. Inform the owner of the kind of performance characteristics to expect from an ASC-equipped vehicle.

When you check if an ASC DTC will be displayed again after the DTC has been erased, you should duplicate the ASC DTC set conditions. Depending on the detection timing and set conditions for the specific ASC DTC, you must either drive the vehicle or turn the engine off and restart it. To set the proper conditions for that DTC again, refer to "ASC DTC SET CONDITIONS" for each ASC DTC that you are trying to reset.

1. Gather information about the problem from the customer.
2. Verify that the condition described by the customer exists.
3. Check the vehicle for any ASC DTC.

4. If you cannot verify the condition and there are no ASC DTCs, the malfunction is intermittent. Refer to GROUP 00, How to use Troubleshooting/Inspection Service Points –How to Cope with Intermittent Malfunctions P.00-15.
5. If you can verify the condition but there are no ASC DTCs, or the system cannot communicate with the scan tool, check that the basic brake system is operating properly.
 - If the basic brake system is not operating properly, refer to the GROUP 35A, Basic Brake System Diagnostic troubleshooting strategy P.35A-4.
 - If the basic brake system is operating properly, refer to P.35C-232.
6. If there is an ASC DTC, record the number of the DTC, then erase the DTC from the memory using the scan tool.
7. Recreate the ASC DTC set conditions to see if the same ASC DTC will set again.
 - If the same ASC DTC sets again, perform the diagnostic procedures for the DTC. Refer to P.35C-22.
 - If you cannot get the same ASC DTC to set again, the malfunction is intermittent. Refer to GROUP 00, How to use Troubleshooting/Inspection Service Points –How to Cope with Intermittent Malfunctions P.00-15.

PRECAUTIONS FOR DIAGNOSIS

M1355009500113

1. ASC controls the brake pressure by the assistance of ECU. The symptoms described in the table below may occur during the normal ASC operation. However, they do not indicate any sign of malfunction.

Symptoms	Description of symptoms
<ul style="list-style-type: none"> • When ASC operates, the operating noise is generated from the motor integrated in the hydraulic unit. (Screech) • Noise is generated from the brake pedal together with the vibration. (Boom, boom) • When ASC operates, the system repeats the activation and deactivation. At this time, the noise is generated from the chassis components. (Clunk: Suspension; Squeak: Tire) 	<p>These noises are generated when the system and brake pedal operate normally, and they do not indicate any sign of malfunction.</p>
<ul style="list-style-type: none"> • A slight shock is felt occasionally when the brake pedal is depressed lightly during the low speed driving. • Small clicking noise is heard occasionally from the engine compartment. 	<p>This noise is generated when the system operation check <startup check performed when the vehicle speed is at few km/h (mile)> is performed, and it does not indicate any malfunction.</p>

2. On snowy or gravel roads, a vehicle with ABS sometimes requires a longer braking distance compared to the one without ABS. Considering this characteristics, advise the customer to drive the vehicle safely at lower speed and not to place too much confidence on the ABS system when driving on such roads.
3. The detection conditions of diagnostic trouble code differ with each diagnostic trouble code. When the trouble symptoms are rechecked, conditions described in the description for the diagnostic trouble code procedures must be satisfied.

ABS WARNING LIGHT, ASC WARNING/OPERATION LIGHT AND BRAKE WARNING LIGHT CHECK

M1352012001071

Check that ABS and brake warning light, ASC warning/operation light illuminate as follows.

NOTE: The brake warning light is used as the warning lights for the parking brake, brake fluid level, and EBD control.

1. When the ignition switch is turned to the ON position, ABS and brake warning light, ASC warning/operation light illuminate.
2. The ABS and brake warning light, ASC warning/operation light illuminate for three seconds^{*1} and then turn OFF^{*2}.
3. Other than the above, the system may have a malfunction. Check the diagnostic trouble code.

NOTE:

- ^{*1}: The ABS warning light may stay ON until the vehicle speed reaches 10 km/h. As far as ABS-ECU stores any diagnostic trouble code related to the wheel speed sensor malfunction or the motor malfunction as past trouble, ABS-ECU continues illuminating the ABS warning light until it verifies that the malfunction for that code is resolved (start-up check).
- ^{*2}: The brake warning light does not turn OFF when the parking brake is applied or the brake fluid level is lowered.

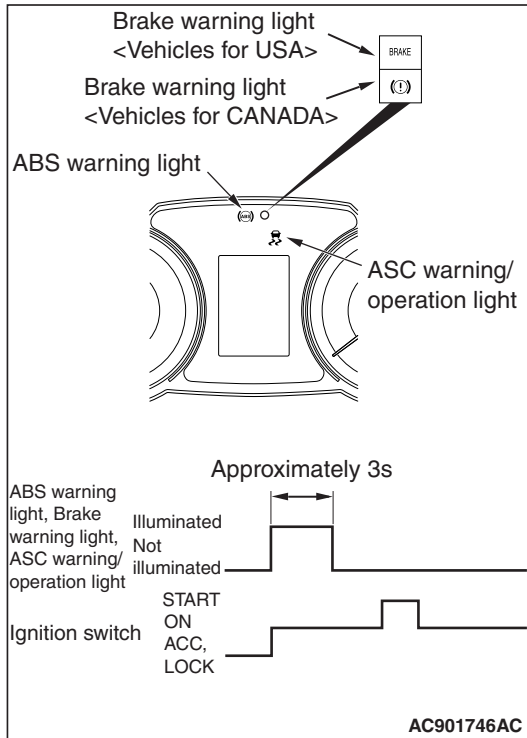

DIAGNOSTIC FUNCTION

ASC-ECU has the following functions for easier system checks. All the following items can be diagnosed using the scan tool.

- Diagnostic trouble code set (Refer to P.35C-22.)
- Service data output (Refer to P.35C-276.)

CHECK OF FREEZE FRAME DATA

The freeze frame data can be checked by using the scan tool.

- Actuator test (Refer to P.35C-278.)
 - Freeze frame data output (Refer to P.35C-8).
- All the above items can be diagnosed using scan tool.

When detecting fault and storing the DTC, the ECU connected to CAN bus line obtains the data before the determination of the DTC and the data when the DTC is determined, and then stores the ECU status of that time. By analyzing each data from scan tool, the troubleshooting can be performed more efficiently. The displayed items are as the table below.

Display item list

Item No.	Item name	Data item	Unit
1	Odometer	Total driving distance after the diagnostic trouble code is generated	mph
2	Ignition cycle	Number of times the ignition switch is turned "ON" or "LOCK (OFF)" after the past failure transition	Number of counts is displayed.
4	Accumulated minute	Cumulative time for current malfunction of diagnostic trouble code	min
5	Power supply voltage	Voltage of power supply when the diagnostic trouble code is generated	V
8	Lateral G sensor	Lateral G of G and yaw rate sensor when the diagnostic trouble code is generated	G
10	Master cylinder pressure	Master cylinder pressure of Master cylinder pressure sensor when the diagnostic trouble code is generated	bar
11	Steering angle	Steering angle of steering wheel sensor when the diagnostic trouble code is generated	bar
12	Yaw rate sensor	Yaw rate of G and yaw rate sensor when the diagnostic trouble code is generated	G
13	Stoplight switch	Stoplight switch condition when the diagnostic trouble code is generated: OFF/ON	-
21	Pump motor	Pump motor condition when the diagnostic trouble code is generated: OFF/ON	-
28	ASC/TCL off switch	ASC OFF switch condition when the diagnostic trouble code is generated: OFF/ON	-
301	ABS control	ABS control when the diagnostic trouble code is generated: OFF/ON	-
302	Brake TCL control	Traction control (brake control) when the diagnostic trouble code is generated: OFF/ON	-
303	Engine TCL control	Traction control (engine control) when the diagnostic trouble code is generated: OFF/ON	-
304	ASC control	ASC control when the diagnostic trouble code is generated: OFF/ON	-
305	Brake TCL operation	Traction control (brake control) operation when the diagnostic trouble code is generated: Permission/Prohibition	-
401	FL wheel speed sensor	Wheel speed (FL) when the diagnostic trouble code is generated	mph
402	FR wheel speed sensor	Wheel speed (FR) when the diagnostic trouble code is generated	mph
403	RL wheel speed sensor	Wheel speed (RL) when the diagnostic trouble code is generated	mph
404	RR wheel speed sensor	Wheel speed (RR) when the diagnostic trouble code is generated	mph

FAIL-SAFE FUNCTIONS

When a malfunction is determined by the diagnostic function, ASC-ECU illuminates the ABS warning light, ABS warning display, brake warning display, brake warning light *, ASC warning display, and ASC OFF display. At the same time, ASC-ECU prohibits the ABS, EBD, stability control, and TCL control.

*NOTE: *: The brake warning light and brake warning display are used as the EBD control warning light.*

Illumination condition of warning light and display in case of failure

DTC No.	Item	Brake warning light, brake warning display	ABS warning light, ABS warning display	ASC warning display	ASC OFF light
C100A	Abnormality in FL wheel speed sensor circuit	Extinguished* ¹	Illuminated* ²	Illuminated	Illuminated
C1015	Abnormality in FR wheel speed sensor circuit				
C1020	Abnormality in RL wheel speed sensor circuit				
C102B	Abnormality in RR wheel speed sensor circuit				
C1011	Abnormality in FL wheel speed sensor signal	Extinguished* ¹	Illuminated* ²	Illuminated	Illuminated
C101C	Abnormality in FR wheel speed sensor signal				
C1027	Abnormality in RL wheel speed sensor signal				
C1032	Abnormality in RR wheel speed sensor signal				
C1014	Mutual monitoring of FL wheel speed sensor	Extinguished* ¹	Illuminated* ²	Illuminated	Illuminated
C101F	Mutual monitoring of FR wheel speed sensor				
C102A	Mutual monitoring of RL wheel speed sensor				
C1035	Mutual monitoring of RR wheel speed sensor				

DTC No.	Item	Brake warning light, brake warning display	ABS warning light, ABS warning display	ASC warning display	ASC OFF light
C1041	Abnormality in periodical signal for FL wheel speed sensor	Extinguished*1	Illuminated*2	Illuminated	Illuminated
C1042	Abnormality in periodical signal for FR wheel speed sensor				
C1043	Abnormality in periodical signal for RL wheel speed sensor				
C1044	Abnormality in periodical signal for RR wheel speed sensor				
C1046	FL wheel speed sensor control phase time exceeded	Extinguished*1	Illuminated*2	Illuminated	Illuminated
C1047	FR wheel speed sensor control phase time exceeded				
C1048	RL wheel speed sensor control phase time exceeded				
C1049	RR wheel speed sensor control phase time exceeded				
C104B	Abnormality in FL wheel inlet valve system	Illuminated	Illuminated	Illuminated	Illuminated
C104F	Abnormality in FR wheel inlet valve system				
C1053	Abnormality in RL wheel inlet valve system				
C1057	Abnormality in RR wheel inlet valve system				
C105F	Abnormality in FL wheel outlet valve system	Illuminated	Illuminated	Illuminated	Illuminated
C1063	Abnormality in FR wheel outlet valve system				
C1067	Abnormality in RL wheel outlet valve system				
C105B	Abnormality in RR wheel outlet valve system				
C1200	Abnormality in FL/RR wheel cut valve system	Illuminated	Illuminated	Illuminated	Illuminated
C1204	Abnormality in FR/RL wheel cut valve system				
C1208	Abnormality in FL/RR wheel suction valve system				
C120C	Abnormality in FR/RL wheel suction valve system				

DTC No.	Item		Brake warning light, brake warning display	ABS warning light, ABS warning display	ASC warning display	ASC OFF light
C2104	Faulty valve power supply circuit		Illuminated	Illuminated	Illuminated	Illuminated
C1073	Faulty motor drive circuit		Extinguished	Illuminated* ²	Illuminated	Illuminated
C2116	Abnormality in power supply voltage in pump motor		Extinguished	Illuminated* ²	Illuminated	Illuminated
C121D	Abnormality in brake fluid pressure sensor circuit		Extinguished	Illuminated	Illuminated	Illuminated
C121E	Abnormality in brake fluid pressure sensor output signal		Extinguished	Illuminated	Illuminated	Illuminated
C2000	Abnormality in wheel fluid pressure sensor circuit		Extinguished	Illuminated	Illuminated	Illuminated
C2001	Abnormality in wheel fluid pressure sensor output signal		Extinguished	Illuminated	Illuminated	Illuminated
C1000	Abnormality in stoplight switch circuit		Extinguished	Extinguished	Illuminated	Illuminated
C123B	Prolonged operation of ASC		Extinguished	Extinguished	Illuminated	Illuminated
C2200	Abnormality in ASC-ECU		Illuminated* ³	Illuminated* ⁴	Illuminated	Illuminated
C2101	Abnormality in battery voltage (high voltage)	18.0 ± 1.0 V or more	Illuminated	Illuminated	Illuminated	Illuminated
C1395	Brake fluid filling not completed		Extinguished	Illuminated	Extinguished	Extinguished
C121C	Torque request signal rejection		Extinguished	Extinguished	Illuminated	Illuminated
C1290	CAN time-out error		Extinguished	Extinguished	Illuminated	Illuminated
C2203	VIN not recorded		Extinguished	Illuminated	Extinguished	Extinguished
C2206	Re-execution of variant coding		Extinguished	Illuminated	Illuminated	Illuminated
C1210	Abnormality in G and yaw rate sensor	Abnormality in longitudinal G-sensor output voltage	Extinguished	Illuminated	Illuminated	Illuminated
C1242	Abnormality in G and yaw rate sensor	Abnormality in longitudinal G-sensor output signal	Extinguished	Illuminated	Illuminated	Illuminated
C123C	Abnormality in G and yaw rate sensor	Abnormality in lateral G and yaw rate output value (incorrect installation)	Extinguished	Extinguished	Illuminated	Illuminated

DTC No.	Item	Brake warning light, brake warning display	ABS warning light, ABS warning display	ASC warning display	ASC OFF light	
C2204	Internal abnormality in G and yaw rate sensor	Abnormality in internal circuit	Extinguished	Illuminated	Illuminated	Illuminated
		Abnormality in lateral G-sensor output voltage	Extinguished	Extinguished	Illuminated	Illuminated
		Abnormality in yaw rate sensor output voltage	Extinguished	Extinguished	Illuminated	Illuminated
		Abnormality in G and yaw rate sensor supply voltage	Extinguished	Illuminated	Illuminated	Illuminated
C2111	Brake fluid pressure sensor power supply circuit	Low input	Extinguished	Illuminated	Illuminated	Illuminated
C2112	Brake fluid pressure sensor power supply circuit	High input	Extinguished	Illuminated	Illuminated	Illuminated
C2114 ^{*5}	Abnormality in G and yaw rate sensor operation voltage	Low voltage (below 6.5 ± 0.5 V)	Extinguished	Illuminated	Illuminated	Illuminated
C2115	Abnormality in G and yaw rate sensor operation voltage	High voltage (18.0 ± 1.0 V or more)	Extinguished	Illuminated	Illuminated	Illuminated
C123A	Abnormality in sensor calibration		Extinguished	Illuminated	Illuminated	Illuminated
C1219	Abnormality in steering wheel sensor signal		Extinguished	Extinguished	Illuminated	Illuminated
C121A	Abnormality in steering wheel sensor initialization	Steering wheel sensor neutral point not learned	Extinguished	ABS warning light: Flashes (2 Hz) ABS warning display: Illuminated	Illuminated	Illuminated
C2205	Internal abnormality in steering wheel sensor		Extinguished	Extinguished	Illuminated	Illuminated
C1608	Implausible diagnosis data		Extinguished	Extinguished	Extinguished	Extinguished

DTC No.	Item		Brake warning light, brake warning display	ABS warning light, ABS warning display	ASC warning display	ASC OFF light
C2002	Abnormality in valve calibration		Illuminated	Illuminated	Illuminated	Illuminated
U0001	Bus-off		Extinguished	Extinguished	Extinguished	Extinguished
U0100	Engine time-out error		Extinguished	Extinguished	Extinguished	Extinguished
U0101 ^{*6}	TC-SST time-out error		Extinguished	Extinguished	Extinguished	Extinguished
U0126	Steering wheel sensor time-out error		Extinguished	Extinguished	Extinguished	Extinguished
U0141	ETACS time-out error		Extinguished	Extinguished	Extinguished	Extinguished
U0136	AWC time-out error		Extinguished	Extinguished	Extinguished	Extinguished
U0125	G and yaw rate sensor message time-out error/message error		Extinguished	Illuminated	Illuminated	Illuminated
U0401	Engine malfunction detected		Extinguished	Extinguished	Illuminated	Illuminated
U0428	Communication error in steering wheel sensor		Extinguished	Extinguished	Illuminated	Illuminated
U0251	AWC time-out error	Local CAN	Extinguished	Extinguished	Extinguished	Extinguished
U0440	Communication error in AWC	Local CAN	Extinguished	Extinguished	Extinguished	Extinguished
U0435	AWC signal abnormality	Local CAN	Extinguished	Extinguished	Extinguished	Extinguished
U1003	G and yaw rate sensor bus-off		Extinguished	Illuminated	Illuminated	Illuminated
U1415	Variant coding not completed		Extinguished	Illuminated	Illuminated	Illuminated
U1417	Variant coding value invalid (includes faulty installation)		Extinguished	Illuminated ^{*4}	Illuminated	Illuminated

NOTE:

- ^{*1}: Turns on when two or more wheels are faulty.
- ^{*2}: Stays on until the vehicle speed reaches 10 km/h when the ignition switch is turned to ON next time.
- ^{*3}: Does not illuminate when there is no effect to the EBD function.
- ^{*4}: Does not illuminate when there is no effect to the ABS function.
- ^{*5}: This DTC is not set with the vehicle speed of 12 mph (20 km/h) or less.
- ^{*6}: Only for vehicles with TC-SST

EBD, ABS, stability control, and TCL control status at failure

DTC No.	Item	EBD	ABS	Stability control	TCL
C100A	Abnormality in FL wheel speed sensor circuit	Executed*1	Prohibited	Prohibited	Prohibited
C1015	Abnormality in FR wheel speed sensor circuit				
C1020	Abnormality in RL wheel speed sensor circuit				
C102B	Abnormality in RR wheel speed sensor circuit				
C1011	Abnormality in FL wheel speed sensor signal	Executed*1	Prohibited	Prohibited	Prohibited
C101C	Abnormality in FR wheel speed sensor signal				
C1027	Abnormality in RL wheel speed sensor signal				
C1032	Abnormality in RR wheel speed sensor signal				
C1014	Mutual monitoring of FL wheel speed sensor	Executed*1	Prohibited	Prohibited	Prohibited
C101F	Mutual monitoring of FR wheel speed sensor				
C102A	Mutual monitoring of RL wheel speed sensor				
C1035	Mutual monitoring of RR wheel speed sensor				
C1041	Abnormality in periodical signal for FL wheel speed sensor	Executed*1	Prohibited	Prohibited	Prohibited
C1042	Abnormality in periodical signal for FR wheel speed sensor				
C1043	Abnormality in periodical signal for RL wheel speed sensor				
C1044	Abnormality in periodical signal for RR wheel speed sensor				
C1046	FL wheel speed sensor control phase time exceeded	Executed*1	Prohibited	Prohibited	Prohibited
C1047	FR wheel speed sensor control phase time exceeded				
C1048	RL wheel speed sensor control phase time exceeded				
C1049	RR wheel speed sensor control phase time exceeded				

DTC No.	Item	EBD	ABS	Stability control	TCL
C104B	Abnormality in FL wheel inlet valve system	Prohibited	Prohibited	Prohibited	Prohibited
C104F	Abnormality in FR wheel inlet valve system				
C1053	Abnormality in RL wheel inlet valve system				
C1057	Abnormality in RR wheel inlet valve system				
C105F	Abnormality in FL wheel outlet valve system	Prohibited	Prohibited	Prohibited	Prohibited
C1063	Abnormality in FR wheel outlet valve system				
C1067	Abnormality in RL wheel outlet valve system				
C105B	Abnormality in RR wheel outlet valve system				
C1200	Abnormality in FL/RR wheel cut valve system	Prohibited	Prohibited	Prohibited	Prohibited
C1204	Abnormality in FR/RL wheel cut valve system				
C1208	Abnormality in FL/RR wheel suction valve system				
C120C	Abnormality in FR/RL wheel suction valve system				
C2104	Faulty valve power supply circuit	Prohibited	Prohibited	Prohibited	Prohibited
C1073	Faulty motor drive circuit	Executed	Prohibited	Prohibited	Prohibited
C2116	Abnormality in power supply voltage in pump motor	Executed	Prohibited	Prohibited	Prohibited
C121D	Abnormality in brake fluid pressure sensor circuit	Executed	Prohibited	Prohibited	Prohibited
C121E	Abnormality in brake fluid pressure sensor output signal	Executed	Prohibited	Prohibited	Prohibited
C2000	Abnormality in wheel fluid pressure sensor circuit	Executed	Prohibited	Prohibited	Prohibited
C2001	Abnormality in wheel fluid pressure sensor output signal	Executed	Prohibited	Prohibited	Prohibited
C1000	Abnormality in stoplight switch circuit	Executed	Executed	Prohibited	Prohibited
C123B	Prolonged operation of ASC	Executed	Executed	Prohibited	Prohibited
C2200	Abnormality in ASC-ECU	Prohibited ^{*2}	Prohibited ^{*3}	Prohibited	Prohibited
C2101	Abnormality in battery voltage (high voltage)	18.0 ± 1.0 V or more	Prohibited	Prohibited	Prohibited
C1395	Brake fluid filling not completed	Executed	Executed	Executed	Executed

DTC No.	Item	EBD	ABS	Stability control	TCL	
C121C	Torque request signal rejection	Executed	Executed	Prohibited	Prohibited	
C1290	CAN time-out error	Executed	Executed	Prohibited	Prohibited	
C2203	VIN not recorded	Executed	Executed	Executed	Executed	
C2206	Re-execution of variant coding	Executed	Prohibited	Prohibited	Prohibited	
C1210	Abnormality in G and yaw rate sensor	Abnormality in longitudinal G sensor output voltage	Executed	Prohibited	Prohibited	Prohibited
C1242	Abnormality in G and yaw rate sensor	Abnormality in longitudinal G sensor output signal	Executed	Prohibited	Prohibited	Prohibited
C123C	Abnormality in G and yaw rate sensor	Abnormality in lateral G and yaw rate output value (incorrect installation)	Executed	Executed	Prohibited	Prohibited
C2204	Internal abnormality in G and yaw rate sensor	Communication error	Executed	Prohibited	Prohibited	Prohibited
		Abnormality in lateral G sensor output voltage	Executed	Executed	Prohibited	Prohibited
		Abnormality in yaw rate sensor output voltage	Executed	Executed	Prohibited	Prohibited
		Abnormality in G and yaw rate sensor supply voltage	Executed	Prohibited	Prohibited	Prohibited
C2111	Brake fluid pressure sensor power supply circuit	Low input	Executed	Prohibited	Prohibited	Prohibited
C2112	Brake fluid pressure sensor power supply circuit	High input	Executed	Prohibited	Prohibited	Prohibited
C2114 ^{*4}	Abnormality in G and yaw rate sensor operation voltage	Low voltage (6.5 ± 0.5 V or less)	Executed	Prohibited	Prohibited	Prohibited
C2115	Abnormality in G and yaw rate sensor operation voltage	High voltage (18.0 ± 1.0 V or more)	Executed	Prohibited	Prohibited	Prohibited
C123A	Abnormality in sensor calibration		Executed	Prohibited	Prohibited	Prohibited
C1219	Abnormality in steering wheel sensor signal		Executed	Executed	Prohibited	Prohibited

DTC No.	Item		EBD	ABS	Stability control	TCL
C121A	Abnormality in steering wheel sensor initialization	Steering wheel sensor neutral point not learned	Executed	Executed	Prohibited	Prohibited
C2205	Internal abnormality in steering wheel sensor		Executed	Executed	Prohibited	Prohibited
C1608	Trouble information data error		Executed	Executed	Executed	Executed
C2002	Abnormality in valve calibration		Prohibited	Prohibited	Prohibited	Prohibited
U0001	Bus-off		Executed	Executed	Executed	Executed
U0100	Engine time-out error		Executed	Executed	Executed	Executed
U0101 ^{*5}	TC-SST time-out error		Executed	Executed	Executed	Executed
U0126	Steering wheel sensor time-out error		Executed	Executed	Executed	Executed
U0141	ETACS time-out error		Executed	Executed	Executed	Executed
U0136	AWC time-out error		Executed	Executed	Executed	Executed
U0125	G and yaw rate sensor message time-out error/message error		Executed	Prohibited	Prohibited	Prohibited
U0401	Engine malfunction detected		Executed	Executed	Prohibited	Prohibited
U0428	Communication error in steering wheel sensor		Executed	Executed	Prohibited	Prohibited
U0251	AWC time-out error	Local CAN	Executed	Executed	Executed	Executed
U0440	Communication error in AWC	Local CAN	Executed	Executed	Executed	Executed
U0435	AWC signal abnormality	Local CAN	Executed	Executed	Executed	Executed
U1003	G and yaw rate sensor bus-off		Executed	Prohibited	Prohibited	Prohibited
U1415	Variant coding not completed		Executed	Prohibited	Prohibited	Prohibited
U1417	Variant coding value invalid (includes faulty installation)		Executed	Prohibited ^{*3}	Prohibited	Prohibited

NOTE:

- ^{*1}: Prohibited when two or more wheels are faulty.
- ^{*2}: Not prohibited when the brake warning light is not illuminated.
- ^{*3}: Not prohibited when the ABS warning light is not illuminated.
- ^{*4}: This DTC is not set with the vehicle speed of 12 mph (20 km/h) or less.
- ^{*5}: Only for vehicles with TC-SST

HOW TO CONNECT THE SCAN TOOL (M.U.T.-III)

Required Special Tools:

- MB991958: Scan Tool (M.U.T.-III Sub Assembly)
 - MB991824: Vehicle Communication Interface (V.C.I.)
 - MB991827: M.U.T.-III USB Cable
 - MB991910: M.U.T.-III Main Harness A

⚠ CAUTION

To prevent damage to scan tool MB991958, always turn the ignition switch to the "LOCK" (OFF) position before connecting or disconnecting scan tool MB991958.

1. Ensure that the ignition switch is at the "LOCK" (OFF) position.
2. Start up the personal computer.
3. Connect special tool MB991827 to special tool MB991824 and the personal computer.
4. Connect special tool MB991910 to the special tool MB991824.
5. Connect special tool MB991910 to the data link connector.
6. Turn the power switch special tool MB991824 to the "ON" position.

NOTE: When the special tool MB991824 is energized, the special tool MB991824 indicator light will be illuminated in a green color.

7. Start the M.U.T.-III system on the personal computer.

NOTE: Disconnect the scan tool MB991958 in the reverse order of the connecting sequence, making sure that the ignition switch is at the "LOCK" (OFF) position.

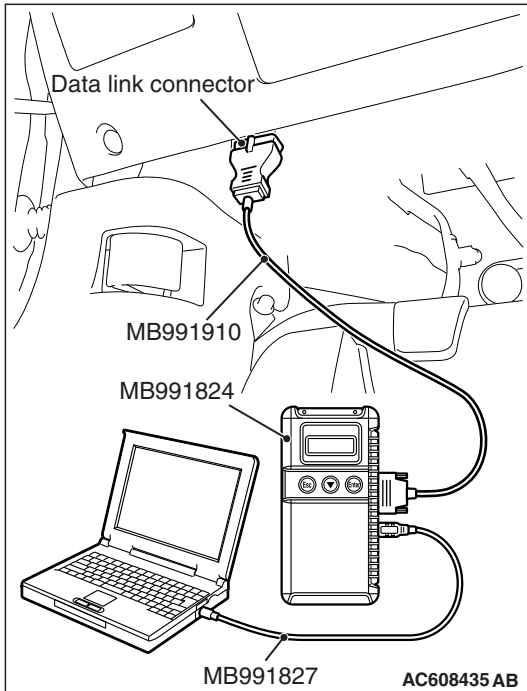

HOW TO READ AND ERASE DIAGNOSTIC TROUBLE CODES

Required Special Tools:

- MB991958: Scan Tool (M.U.T.-III Sub Assembly)
 - MB991824: Vehicle Communication Interface (V.C.I.)
 - MB991827: M.U.T.-III USB Cable
 - MB991910: M.U.T.-III Main Harness A

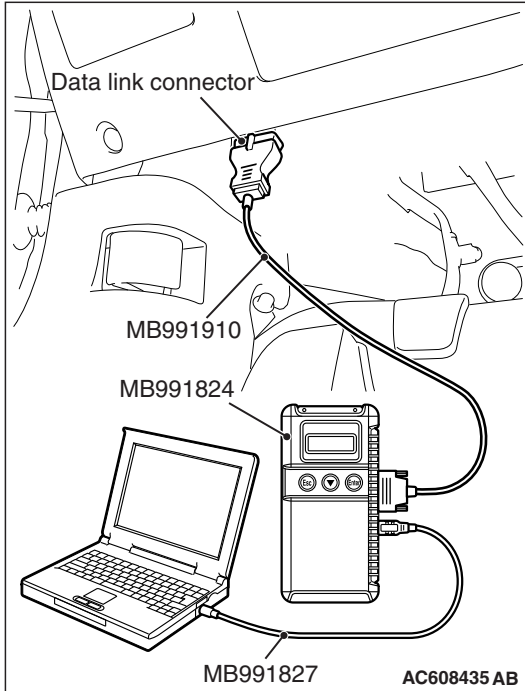
**⚠ CAUTION**

To prevent damage to scan tool MB991958, always turn the ignition switch to the "LOCK" (OFF) position before connecting or disconnecting scan tool MB991958.

NOTE: If the battery voltage is low, diagnostic trouble codes will not be set. Check the battery if scan tool MB991958 does not display.

1. Connect scan tool MB991958 to the data link connector.
2. Turn the ignition switch to the "ON" position.
3. Select "System Select."
4. Select "ABS/ASC/ASTC" from the system list, and select the "OK" button.
5. Select "Diagnostic Trouble Code" to read the DTC.
6. If a DTC is set, it is shown.
7. Choose "DTC erase" to erase the DTC.

HOW TO READ DATA LIST**Required Special Tools:**

- MB991958: Scan Tool (M.U.T.-III Sub Assembly)
 - MB991824: Vehicle Communication Interface (V.C.I.)
 - MB991827: M.U.T.-III USB Cable
 - MB991910: M.U.T.-III Main Harness A

⚠ CAUTION

To prevent damage to scan tool MB991958, always turn the ignition switch to the "LOCK" (OFF) position before connecting or disconnecting scan tool MB991958.

1. Connect scan tool MB991958 to the data link connector.
2. Turn the ignition switch to the "ON" position.
3. Select "System Select."
4. Select "ABS/ASC/ASTC" from the system list, and select the "OK" button.
5. Select "Data List."

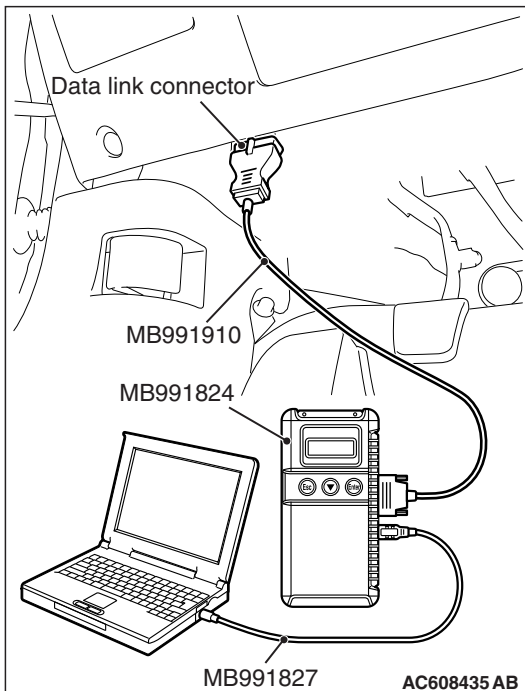

HOW TO PERFORM ACTUATOR TEST

Required Special Tools:

- MB991958: Scan Tool (M.U.T.-III Sub Assembly)
 - MB991824: Vehicle Communication Interface (V.C.I.)
 - MB991827: M.U.T.-III USB Cable
 - MB991910: M.U.T.-III Main Harness A

⚠ CAUTION

To prevent damage to scan tool MB991958, always turn the ignition switch to the "LOCK" (OFF) position before connecting or disconnecting scan tool MB991958.

1. Connect scan tool MB991958 to the data link connector.
2. Turn the ignition switch to the "ON" position.
3. Select "System Select."
4. Select "ABS/ASC/ASTC" from the system list, and select the "OK" button.
5. Choose "Actuator Test" from "ABS" screen.
6. Choose an appropriate item and select the "OK" button.

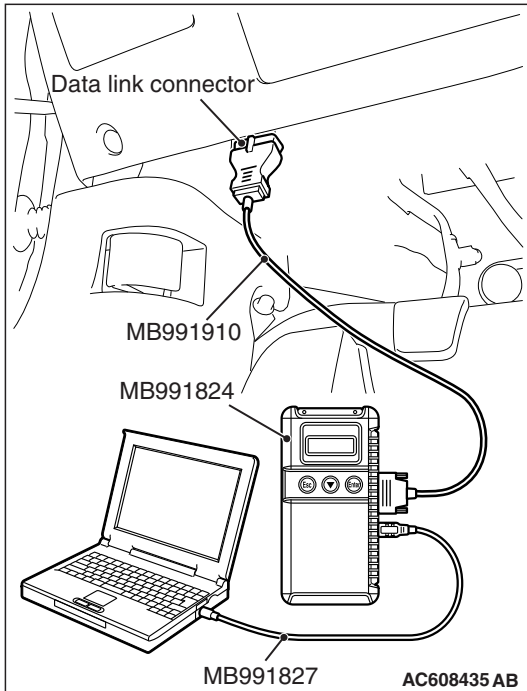

DIAGNOSTIC TROUBLE CODE CHART

M1355001100371

⚠ CAUTION

During diagnosis, a DTC code associated with another system may be set when the ignition switch is turned on with connector(s) disconnected. On completion, confirm all systems for DTCs. If DTC code(s) are set, erase them all.

DTC No.	Item	Reference page	
C100A	Abnormality in FL wheel speed sensor circuit	P.35C-25	
C1015	Abnormality in FR wheel speed sensor circuit	P.35C-30	
C1020	Abnormality in RL wheel speed sensor circuit	P.35C-35	
C102B	Abnormality in RR wheel speed sensor circuit	P.35C-40	
C1011	Abnormality in FL wheel speed sensor signal	P.35C-45	
C101C	Abnormality in FR wheel speed sensor signal	P.35C-52	
C1027	Abnormality in RL wheel speed sensor signal	P.35C-59	
C1032	Abnormality in RR wheel speed sensor signal	P.35C-66	
C1014	Mutual monitoring of FL wheel speed sensor	P.35C-72	
C101F	Mutual monitoring of FR wheel speed sensor	P.35C-76	
C102A	Mutual monitoring of RL wheel speed sensor	P.35C-79	
C1035	Mutual monitoring of RR wheel speed sensor	P.35C-82	
C1041	Abnormality in periodical signal for FL wheel speed sensor	P.35C-85	
C1042	Abnormality in periodical signal for FR wheel speed sensor	P.35C-88	
C1043	Abnormality in periodical signal for RL wheel speed sensor	P.35C-90	
C1044	Abnormality in periodical signal for RR wheel speed sensor	P.35C-92	
C1046	FL wheel speed sensor control phase time exceeded	P.35C-95	
C1047	FR wheel speed sensor control phase time exceeded	P.35C-101	
C1048	RL wheel speed sensor control phase time exceeded	P.35C-107	
C1049	RR wheel speed sensor control phase time exceeded	P.35C-114	
C104B	Abnormality in FL wheel inlet valve system	P.35C-120	
C104F	Abnormality in FR wheel inlet valve system		
C1053	Abnormality in RL wheel inlet valve system		
C1057	Abnormality in RR wheel inlet valve system		
C105F	Abnormality in FL wheel outlet valve system		
C1063	Abnormality in FR wheel outlet valve system		
C1067	Abnormality in RL wheel outlet valve system		
C105B	Abnormality in RR wheel outlet valve system		
C1200	Abnormality in FL/RR wheel cut valve system		
C1204	Abnormality in FR/RL wheel cut valve system		
C1208	Abnormality in FL/RR wheel suction valve system		
C120C	Abnormality in FR/RL wheel suction valve system		
C2104	Faulty valve power supply circuit		P.35C-122
C1073	Faulty motor drive circuit		P.35C-127

DTC No.	Item		Reference page
C2116	Abnormality in power supply voltage in pump motor		P.35C-132
C121D	Abnormality in brake fluid pressure sensor circuit		P.35C-137
C121E	Abnormality in brake fluid pressure sensor output signal		P.35C-139
C2000	Abnormality in wheel fluid pressure sensor circuit		P.35C-142
C2001	Abnormality in wheel fluid pressure sensor output signal		P.35C-143
C1000	Abnormality in stoplight switch circuit		P.35C-147
C123B	Prolonged operation of ASC		P.35C-155
C2200	Abnormality in ASC-ECU		P.35C-158
C2101	Abnormality in battery voltage (high voltage)	18.0 ± 1.0 V or more	P.35C-159
C1395	Brake fluid filling not completed		P.35C-165
C121C	Torque request signal rejection		P.35C-166
C1290	CAN time-out error		P.35C-168
C2203	VIN not recorded		P.35C-171
C2206	Re-execution of variant coding		P.35C-173
C1210	Abnormality in G and yaw rate sensor	Abnormality in longitudinal G-sensor output voltage	P.35C-175
C1242	Abnormality in G and yaw rate sensor	Abnormality in longitudinal G-sensor output signal	P.35C-177
C123C	Abnormality in G and yaw rate sensor	Abnormality in lateral G and yaw rate output value (incorrect installation)	P.35C-180
C2204	Internal abnormality in G and yaw rate sensor	Abnormality in internal circuit	P.35C-183
		Abnormality in lateral G-sensor output voltage	
		Abnormality in yaw rate sensor output voltage	
		Abnormality in G and yaw rate sensor supply voltage	
C2111	Brake fluid pressure sensor power supply circuit	Low input	P.35C-185
C2112	Brake fluid pressure sensor power supply circuit	High input	
C2114	Abnormality in G and yaw rate sensor operation voltage	Low voltage (below 6.5 ± 0.5 V)	P.35C-187
C2115	Abnormality in G and yaw rate sensor operation voltage	High voltage (18.0 ± 1.0 V or more)	
C123A	Abnormality in sensor calibration		P.35C-191
C1219	Abnormality in steering wheel sensor signal		P.35C-193
C121A	Abnormality in steering wheel sensor initialization	Steering wheel sensor neutral point not learned	P.35C-196

DTC No.	Item	Reference page	
C2205	Internal abnormality in steering wheel sensor	P.35C-197	
C1608	Implausible diagnosis data	P.35C-199	
C2002	Abnormality in valve calibration	P.35C-206	
U0001	Bus-off	P.35C-208	
U0100	Engine time-out error	P.35C-209	
U0101*	TC-SST time-out error		
U0126	Steering wheel sensor time-out error		
U0141	ETACS time-out error		
U0136	AWC time-out error		
U0125	G and yaw rate sensor message time-out error/message error		P.35C-212
U0401	Engine malfunction detected	P.35C-215	
U0428	Communication error in steering wheel sensor	P.35C-217	
U0251	AWC time-out error	Local CAN	P.35C-219
U0440	Communication error in AWC	Local CAN	
U0435	AWC signal abnormality	Local CAN	
U1003	G and yaw rate sensor bus-off	P.35C-223	
U1415	Variant coding not completed	P.35C-226	
U1417	Variant coding value invalid (includes faulty installation)	P.35C-228	

NOTE: *: Only for vehicles with TC-SST

DIAGNOSTIC TROUBLE CODE PROCEDURES

DTC C100A: Abnormality in FL wheel speed sensor circuit

Wheel Speed Sensor Circuit

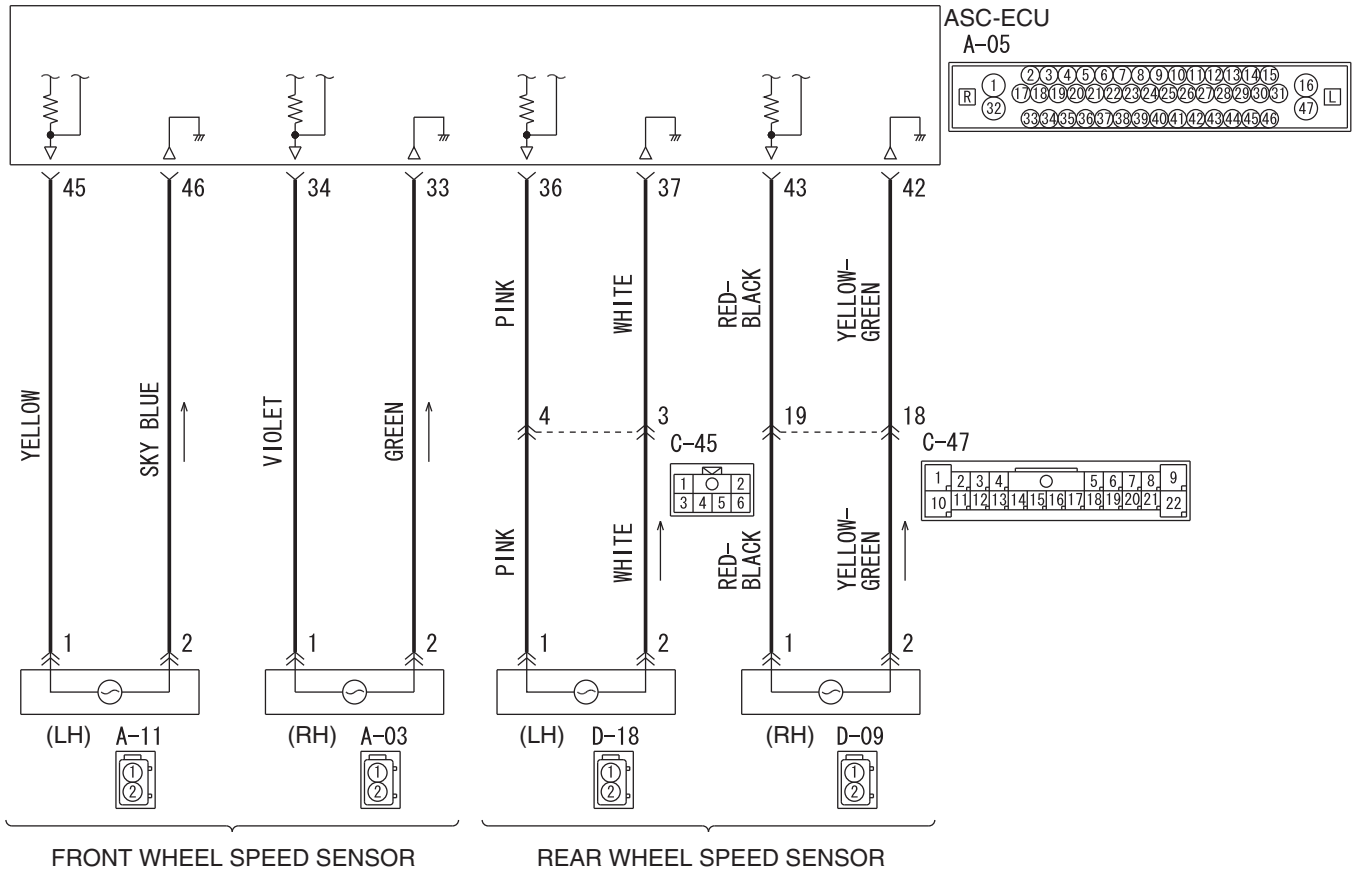

AC804587

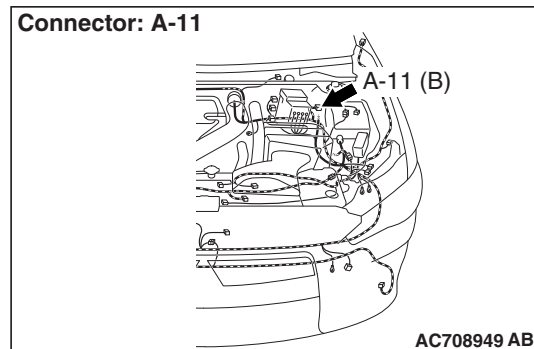
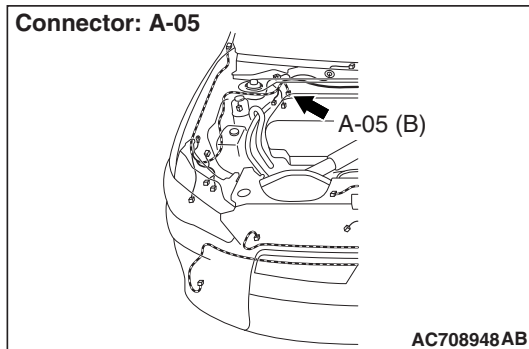

⚠ CAUTION

- If there is any problem in the CAN bus lines, an incorrect diagnostic trouble code may be set. Prior to this diagnosis, diagnose the CAN bus lines.
- Whenever the ECU is replaced, ensure that the CAN bus lines are normal.
- When the hydraulic unit (integrated with ASC-ECU) is replaced, always perform the calibration of steering wheel sensor, G and yaw rate sensor, brake fluid pressure sensor, cut valve, and inlet valve. (Refer to [P.35C-287](#), [P.35C-289](#), [P.35C-294](#), and [P.35C-295](#).)

CIRCUIT OPERATION

- Each wheel speed detecting section is a kind of a pulse generator. It consists of the encoder (plate on which the north and south pole of magnet are arranged alternately) for detecting the wheel speed, which rotates at the same speed of the wheels, and the wheel speed sensor. This detecting section outputs the frequency pulse signals in proportion to the wheel speed.
- The pulse signals generated by the wheel speed detecting section are sent to ASC-ECU. ASC-ECU uses the frequency of the pulse signals to determine the wheel speed.

DTC SET CONDITIONS

ASC-ECU monitors the electric current in each wheel speed sensor circuit. If an open or short circuit in the wheel speed sensor circuit is detected, ASC-ECU sets a corresponding diagnostic trouble code.

PROBABLE CAUSES**Current trouble**

- Damaged wiring harness and connectors
- Noise interference
- Malfunction of wheel speed sensor
- ABS-ECU malfunction

Past trouble

- Carry out the diagnosis with a particular emphasis on the wiring harness and connector failures between ASC-ECU and the wheel speed sensor. For diagnosis procedures, refer to How to Treat Past Trouble (GROUP 00 –How to Use Troubleshooting/Inspection Service Points [P.00-16](#)).

DIAGNOSIS**Required Special Tools:**

- MB991958 Scan Tool (M.U.T.-III Sub Assembly)
 - MB991824: Vehicle Communication Interface (V.C.I.)
 - MB991827 M.U.T.-III USB Cable
 - MB991910 M.U.T.-III Main Harness A
- MB991997: ASC check harness

STEP 1. Using scan tool MB991958, diagnose the CAN bus lines.

Using scan tool MB991958, diagnose the CAN bus lines.

Q: Is the check result normal?

YES : Go to Step 3.

NO : Repair the CAN bus lines (Refer to GROUP 54C – CAN Bus Diagnostics table P.54C-9). On completion, go to Step 2.

STEP 2. DTC recheck after repairing the CAN bus line

Q: Is DTC C100A set?

YES : Go to Step 3.

NO : This diagnosis is complete.

STEP 3. Scan tool service data

Check the following service data. (Refer to P.35C-276.)

- Item No.01: FL wheel speed sensor

Q: Is the check result normal?

YES : Go to Step 10.

NO : Go to Step 4.

STEP 4. Connector check: A-05 ASC-ECU connector, A-11 wheel speed sensor <FL> connector

Q: Is the check result normal?

YES : Go to Step 5.

NO : Repair the defective connector. Then go to Step 11.

STEP 5. Voltage measurement at A-05 ASC-ECU connector

- (1) Disconnect the ASC-ECU connector, connect the special tool ASC check harness (MB991997) to the wiring harness-side connector, and then measure at the special tool connector side.

NOTE: Do not connect the special tool to ASC-ECU.

- (2) Turn the ignition switch to the ON position.
- (3) Measure the voltage between the wheel speed sensor power supply terminal (signal terminal) No. 45 and the body ground as well as between the ground terminal No. 46 and the body ground.

OK: 1 volt or less

Q: Is the check result normal?

YES : Go to Step 6.

NO (Not normal at the terminal No. 45 or 46) : Go to Step 8.

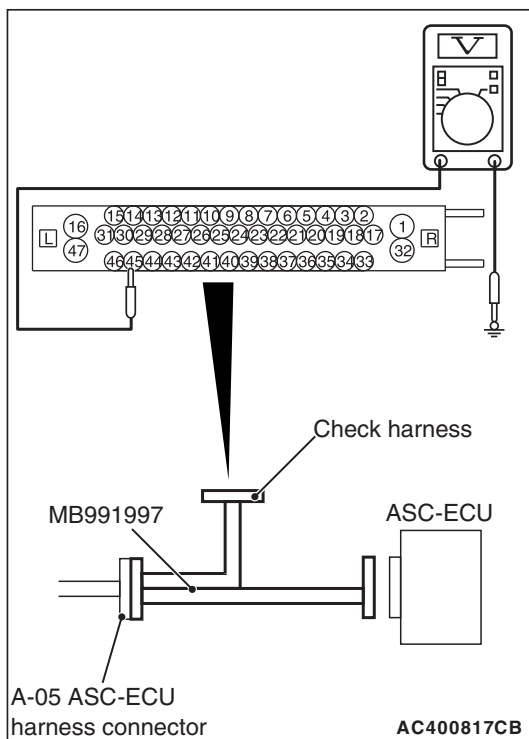

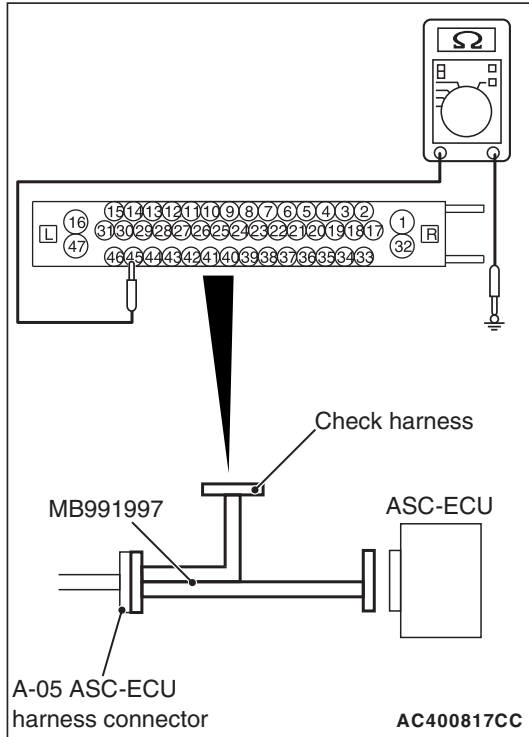

STEP 6. Resistance measurement at A-05 ASC-ECU connector

- (1) Disconnect the ASC-ECU connector, connect the special tool ASC check harness (MB991997) to the wiring harness-side connector, and then measure at the special tool connector side.

NOTE: Do not connect the special tool to ASC-ECU.

- (2) Measure the resistance between the wheel speed sensor circuit power supply terminal (signal terminal) No. 45 and the body ground as well as between the ground terminal No. 46 and the body ground.

OK: No continuity

Q: Is the check result normal?

YES : Go to Step 7.

NO (Not normal at the terminal No. 45 or 46) : Go to Step 8.

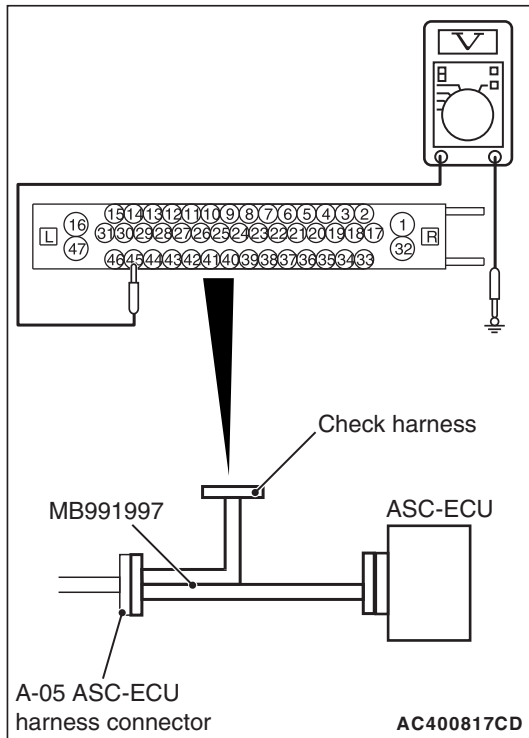

STEP 7. Voltage measurement at A-05 ASC-ECU connector

- (1) Disconnect the ASC-ECU connector, connect special tool ASC check harness (MB991997) to the ASC-ECU-side connector and the wiring harness-side connector, and then measure at the special tool connector side.
- (2) Turn the ignition switch to the ON position.
- (3) Measure the voltage between the wheel speed sensor circuit power supply terminal (signal terminal) No. 45 and the body ground and between the wheel speed sensor circuit ground terminal No. 46 and the body ground.

OK:

Terminal No.45 and the body ground: Battery positive voltage

Terminal No.46 and the body ground: 1 V or less

Q: Is the check result normal?

YES : Go to Step 8.

NO : Go to Step 10.

STEP 8. Check of wheel speed sensor as a single unit

Refer to [P.35C-303](#).

Q: Is the check result normal?

YES : Go to Step 9.

NO : Replace the wheel speed sensor <FL>. (Refer to [P.35C-300](#).) Then go to Step 11.

STEP 9. Wiring harness check between A-05 ASC-ECU connector terminal No. 45 and A-11 wheel speed sensor <FL> connector terminal No. 1, and between A-05 ASC-ECU connector terminal No. 46 and A-11 wheel speed sensor <FL> connector terminal No. 2

- Check for short or open circuit in wheel speed sensor <FL> circuit

Q: Is the check result normal?

YES : Go to Step 10.

NO : Repair the wiring harness. Then go to Step 11.

STEP 10. Check whether the DTC is reset.

(1) Erase the DTC.

(2) Drive the vehicle at 12mph (20 km/h) or more.

NOTE: The ABS warning light does not turn OFF in some cases unless the vehicle runs at 12mph (20 km/h) or higher.

Q: Is DTC C100A set?

YES : Replace the hydraulic unit (incorporates in ASC-ECU).(Refer to [P.35C-298](#).) Then go to Step 11.

NO : Intermittent malfunction. (Refer to GROUP 00 –How to Cope with Intermittent Malfunction [P.00-15](#).)

STEP 11. Check whether the DTC is reset.

(1) Erase the DTC.

(2) Drive the vehicle at 12mph (20 km/h) or more.

NOTE: The ABS warning light does not turn OFF in some cases unless the vehicle runs at 12mph (20 km/h) or higher.

Q: Is DTC C100A set?

YES : Return to Step 1.

NO : This diagnosis is complete.

DTC C1015: Abnormality in FR wheel speed sensor circuit

Wheel Speed Sensor Circuit

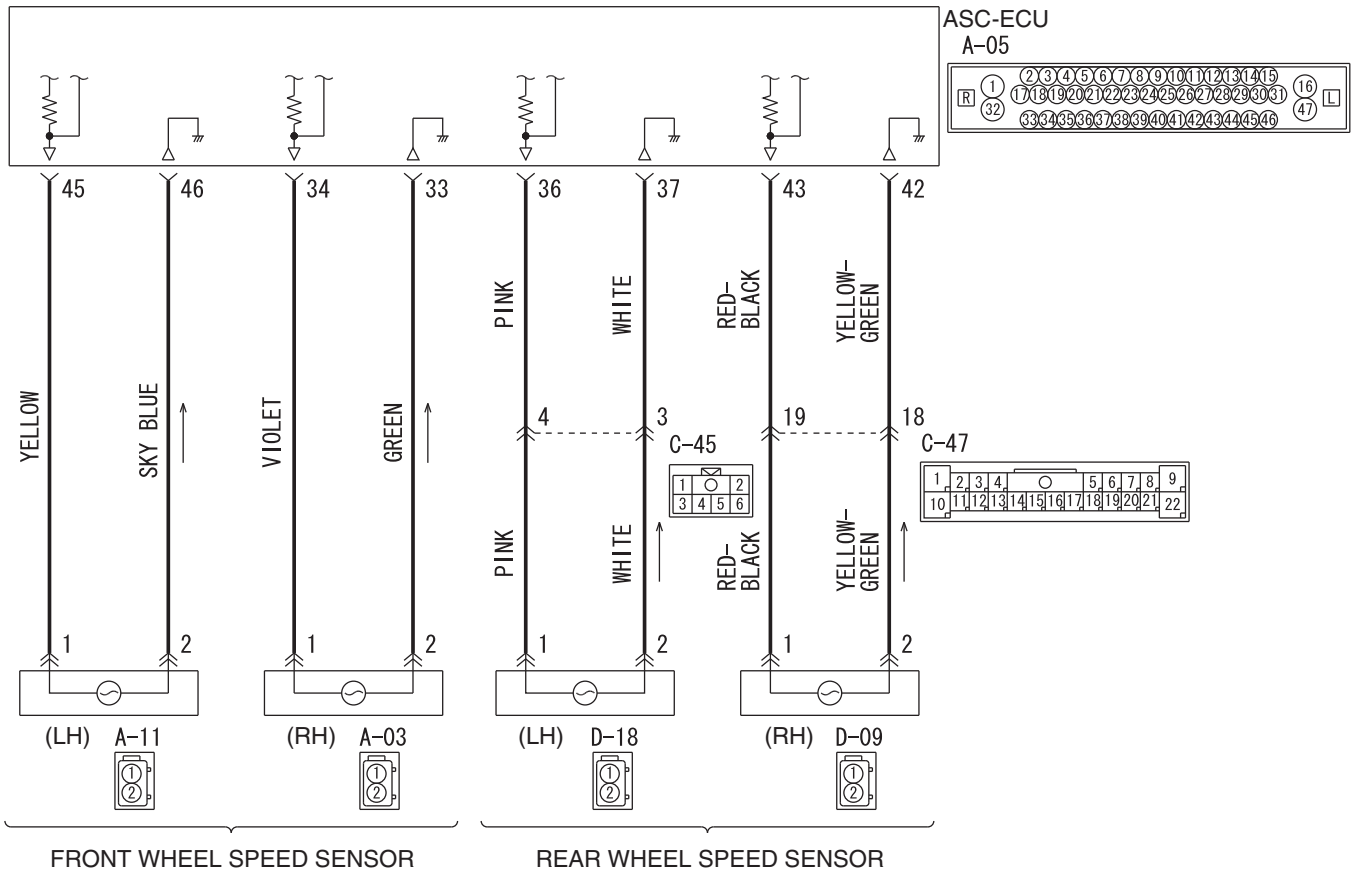

AC804587

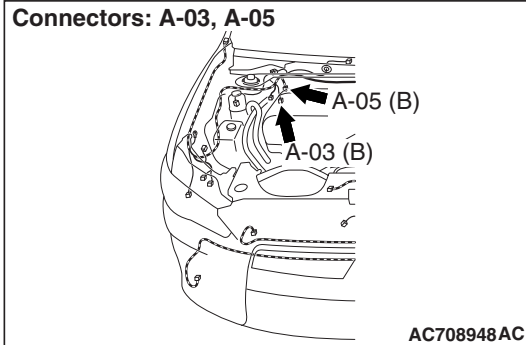

⚠ CAUTION

- If there is any problem in the CAN bus lines, an incorrect diagnostic trouble code may be set. Prior to this diagnosis, diagnose the CAN bus lines.
- Whenever the ECU is replaced, ensure that the CAN bus lines are normal.
- When the hydraulic unit (integrated with ASC-ECU) is replaced, always perform the calibration of steering wheel sensor, G and yaw rate sensor, brake fluid pressure sensor, cut valve, and inlet valve.(Refer to [P.35C-287](#), [P.35C-289](#), [P.35C-294](#), and [P.35C-295](#).)

CIRCUIT OPERATION

- Each wheel speed detecting section is a kind of a pulse generator. It consists of the encoder (plate on which the north and south pole of magnet are arranged alternately) for detecting the wheel speed, which rotates at the same speed of the wheels, and the wheel speed sensor. This detecting section outputs the frequency pulse signals in proportion to the wheel speed.
- The pulse signals generated by the wheel speed detecting section are sent to ASC-ECU. ASC-ECU uses the frequency of the pulse signals to determine the wheel speed.

DTC SET CONDITIONS

ASC-ECU monitors the electric current in each wheel speed sensor circuit. If an open or short circuit in the wheel speed sensor circuit is detected, ASC-ECU sets a corresponding diagnostic trouble code.

PROBABLE CAUSES

Current trouble

- Damaged wiring harness and connectors
- Noise interference
- Malfunction of wheel speed sensor
- ASC-ECU malfunction

Past trouble

- Carry out the diagnosis with a particular emphasis on the wiring harness and connector failures between ASC-ECU and the wheel speed sensor. For diagnosis procedures, refer to How to Treat Past Trouble (GROUP 00 –How to Use Troubleshooting/Inspection Service Points [P.00-16](#)).

DIAGNOSIS

Required Special Tools:

- MB991958 Scan Tool (M.U.T.-III Sub Assembly)
 - MB991824: Vehicle Communication Interface (V.C.I.)
 - MB991827 M.U.T.-III USB Cable
 - MB991910 M.U.T.-III Main Harness A
- MB991997: ASC check harness

STEP 1. Using scan tool MB991958, diagnose the CAN bus lines.

Using scan tool MB991958, diagnose the CAN bus lines.

Q: Is the check result normal?

YES : Go to Step 3.

NO : Repair the CAN bus lines (Refer to GROUP 54C – CAN Bus Diagnostics table P.54C-9). On completion, go to Step 2.

STEP 2. DTC recheck after repairing the CAN bus line**Q: Is DTC No. C1015 set?**

YES : Go to Step 3.

NO : This diagnosis is complete.

STEP 3. Scan tool service data

Check the following service data. (Refer to P.35C-276.)

- Item No.02: FR wheel speed sensor

Q: Is the check result normal?

YES : Go to Step 10.

NO : Go to Step 4.

STEP 4. Connector check: A-05 ASC-ECU connector, A-03 wheel speed sensor <FR> connector**Q: Is the check result normal?**

YES : Go to Step 5.

NO : Repair the defective connector. Then go to Step 11.

STEP 5. Voltage measurement at A-05 ASC-ECU connector

- (1) Disconnect the ASC-ECU connector, connect the special tool ASC check harness (MB991997) to the wiring harness-side connector, and then measure at the special tool connector side.

NOTE: Do not connect the special tool to ASC-ECU.

- (2) Turn the ignition switch to the ON position.
- (3) Measure the voltage between the wheel speed sensor power supply terminal (signal terminal) No. 34 and the body ground as well as between the ground terminal No. 33 and the body ground.

OK: 1 volt or less

Q: Is the check result normal?

YES : Go to Step 6.

NO (Not normal at the terminal No. 34 or 33) : Go to Step 8.

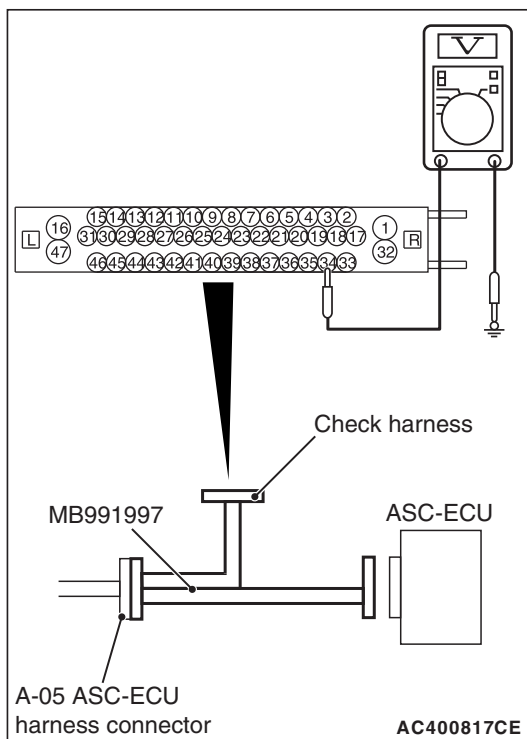

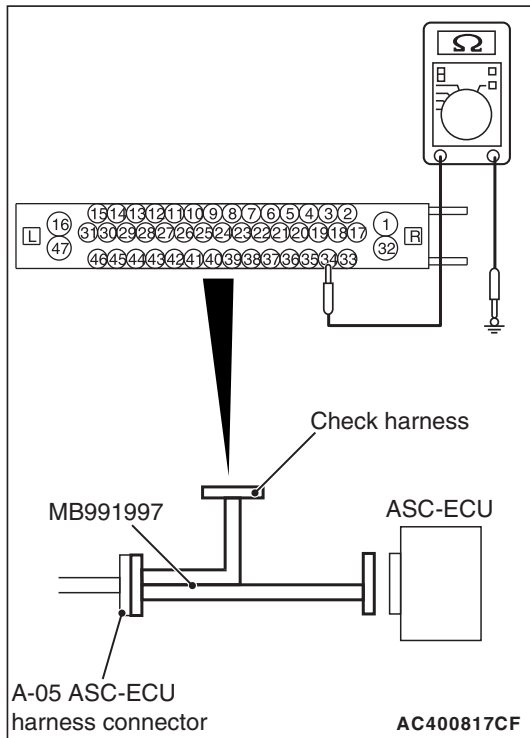

STEP 6. Resistance measurement at A-05 ASC-ECU connector

- (1) Disconnect the ASC-ECU connector, connect the special tool ASC check harness (MB991997) to the wiring harness-side connector, and then measure at the special tool connector side.

NOTE: Do not connect the special tool to ASC-ECU.

- (2) Measure the resistance between the wheel speed sensor circuit power supply terminal (signal terminal) No. 34 and the body ground as well as between the ground terminal No. 33 and the body ground.

OK: No continuity

Q: Is the check result normal?

YES : Go to Step 7.

NO (Not normal at the terminal No. 34 or 33) : Go to Step 8.

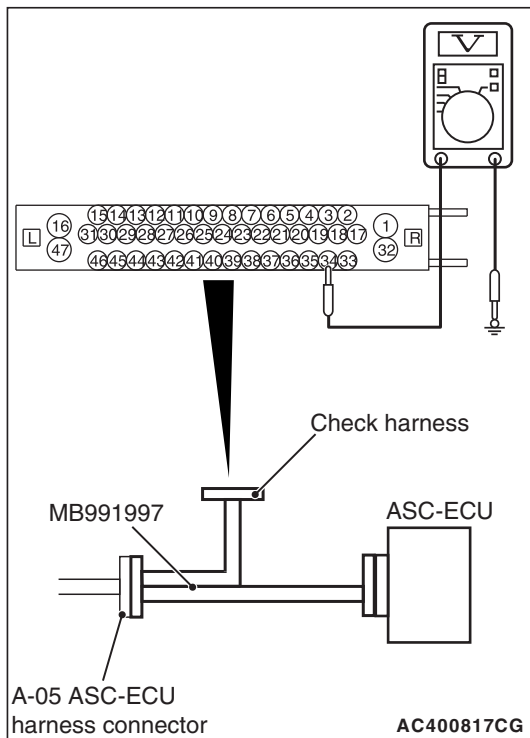

STEP 7. Voltage measurement at A-05 ASC-ECU connector

- (1) Disconnect the ASC-ECU connector, connect special tool ASC check harness (MB991997) to the ASC-ECU-side connector and the wiring harness-side connector, and then measure at the special tool connector side.
- (2) Turn the ignition switch to the ON position.
- (3) Measure the voltage between the wheel speed sensor circuit power supply terminal (signal terminal) No. 34 and the body ground and between the wheel speed sensor circuit ground terminal No. 33 and the body ground.

OK:

Terminal No.34 and the body ground: Battery positive voltage

Terminal No.33 and the body ground: 1 V or less

Q: Is the check result normal?

YES : Go to Step 8.

NO : Go to Step 10.

STEP 8. Check of wheel speed sensor as a single unit

Refer to [P.35C-303](#).

Q: Is the check result normal?

YES : Go to Step 9.

NO : Replace the wheel speed sensor <FR>. (Refer to [P.35C-300](#).) Then go to Step 11.

STEP 9. Wiring harness check between A-05 ASC-ECU connector terminal No. 34 and A-03 wheel speed sensor <FR> connector terminal No. 1, and between A-05 ASC-ECU connector terminal No. 33 and A-03 wheel speed sensor <FR> connector terminal No. 2

- Check for short or open circuit in wheel speed sensor <FR> circuit

Q: Is the check result normal?

YES : Go to Step 10.

NO : Repair the wiring harness. Then go to Step 11.

STEP 10. Check whether the DTC is reset.

- (1) Erase the DTC.
- (2) Drive the vehicle at 12mph (20 km/h) or more.

NOTE: The ABS warning light does not turn OFF in some cases unless the vehicle runs at 12mph (20 km/h) or higher.

Q: Is DTC C1015 set?

YES : Replace the hydraulic unit (incorporates in ASC-ECU).(Refer to [P.35C-298](#).) Then go to Step 11.

NO : Intermittent malfunction. (Refer to GROUP 00 –How to Cope with Intermittent Malfunction [P.00-15](#).)

STEP 11. Check whether the DTC is reset.

- (1) Erase the DTC.
- (2) Drive the vehicle at 12mph (20 km/h) or more.

NOTE: The ABS warning light does not turn OFF in some cases unless the vehicle runs at 12mph (20 km/h) or higher.

Q: Is DTC C1015 set?

YES : Return to Step 1.

NO : This diagnosis is complete.

DTC C1020: Abnormality in RL wheel speed sensor circuit

Wheel Speed Sensor Circuit

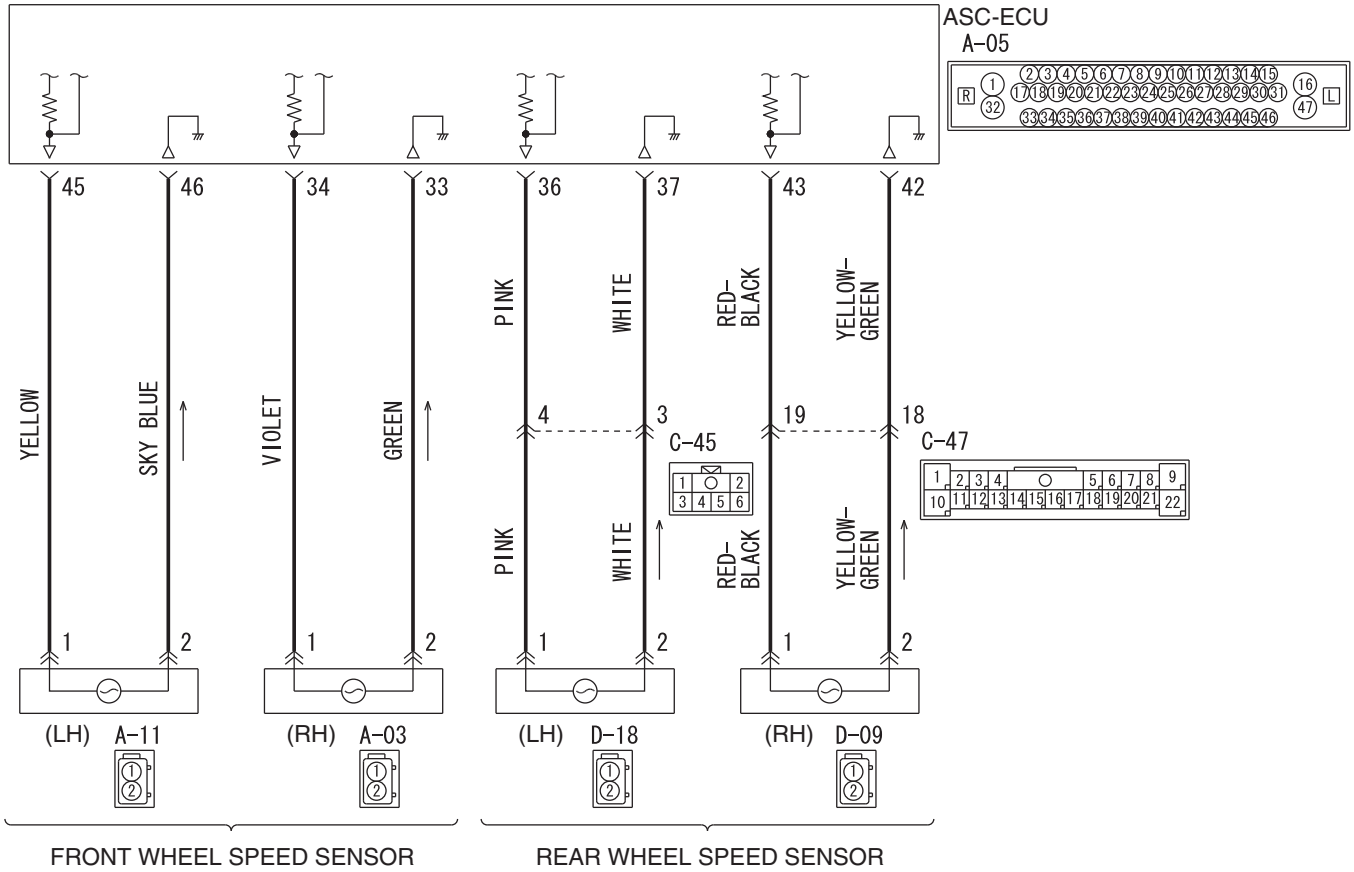

AC804587

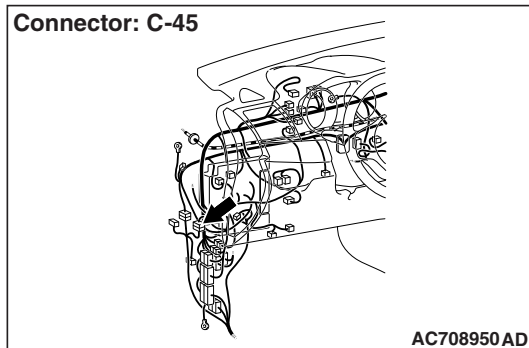
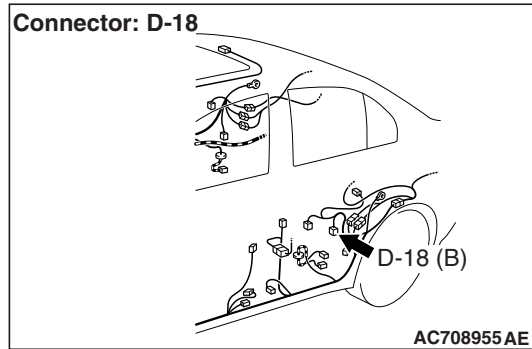
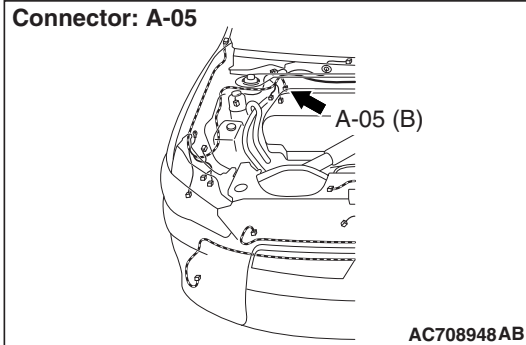

⚠ CAUTION

- If there is any problem in the CAN bus lines, an incorrect diagnostic trouble code may be set. Prior to this diagnosis, diagnose the CAN bus lines.
- Whenever the ECU is replaced, ensure that the CAN bus lines are normal.
- When the hydraulic unit (integrated with ASC-ECU) is replaced, always perform the calibration of steering wheel sensor, G and yaw rate sensor, brake fluid pressure sensor, cut valve, and inlet valve. (Refer to [P.35C-287](#), [P.35C-289](#), [P.35C-294](#), and [P.35C-295](#).)

CIRCUIT OPERATION

- Each wheel speed detecting section is a kind of a pulse generator. It consists of the encoder (plate on which the north and south pole of magnet are arranged alternately) for detecting the wheel speed, which rotates at the same speed of the wheels, and the wheel speed sensor. This detecting section outputs the frequency pulse signals in proportion to the wheel speed.
- The pulse signals generated by the wheel speed detecting section are sent to ASC-ECU. ASC-ECU uses the frequency of the pulse signals to determine the wheel speed.

DTC SET CONDITIONS

ASC-ECU monitors the electric current in each wheel speed sensor circuit. If an open or short circuit in the wheel speed sensor circuit is detected, ASC-ECU sets a corresponding diagnostic trouble code.

PROBABLE CAUSES**Current trouble**

- Damaged wiring harness and connectors
- Noise interference
- Malfunction of wheel speed sensor
- ASC-ECU malfunction

Past trouble

- Carry out the diagnosis with a particular emphasis on the wiring harness and connector failures between ASC-ECU and the wheel speed sensor. For diagnosis procedures, refer to How to Treat Past Trouble (GROUP 00 –How to Use Troubleshooting/Inspection Service Points [P.00-16](#)).

DIAGNOSIS**Required Special Tools:**

- MB991958 Scan Tool (M.U.T.-III Sub Assembly)
 - MB991824: Vehicle Communication Interface (V.C.I.)
 - MB991827 M.U.T.-III USB Cable
 - MB991910 M.U.T.-III Main Harness A
- MB991997: ASC check harness

STEP 1. Using scan tool MB991958, diagnose the CAN bus lines.

Using scan tool MB991958, diagnose the CAN bus lines.

Q: Is the check result normal?

YES : Go to Step 3.

NO : Repair the CAN bus lines (Refer to GROUP 54C – CAN Bus Diagnostics table P.54C-9). On completion, go to Step 2.

STEP 2. DTC recheck after repairing the CAN bus line

Q: Is DTC C1020 set?

YES : Go to Step 3.

NO : This diagnosis is complete.

STEP 3. Scan tool service data

Check the following service data. (Refer to P.35C-276.)

- Item No.03: RL wheel speed sensor

Q: Is the check result normal?

YES : Go to Step 10.

NO : Go to Step 4.

STEP 4. Connector check: Connector check: A-05 ASC-ECU connector, C-45 intermediate connector, D-18 wheel speed sensor <RL> connector

Q: Is the check result normal?

YES : Go to Step 5.

NO : Repair the defective connector. Then go to Step 11.

STEP 5. Voltage measurement at A-05 ASC-ECU connector

- (1) Disconnect the ASC-ECU connector, connect the special tool ASC check harness (MB991997) to the wiring harness-side connector, and then measure at the special tool connector side.

NOTE: Do not connect the special tool to ASC-ECU.

- (2) Turn the ignition switch to the ON position.
- (3) Measure the voltage between the wheel speed sensor power supply terminal (signal terminal) No. 36 and the body ground as well as between the ground terminal No. 37 and the body ground.

OK: 1 volt or less

Q: Is the check result normal?

YES : Go to Step 6.

NO (Not normal at the terminal No. 34 or 33) : Go to Step 8.

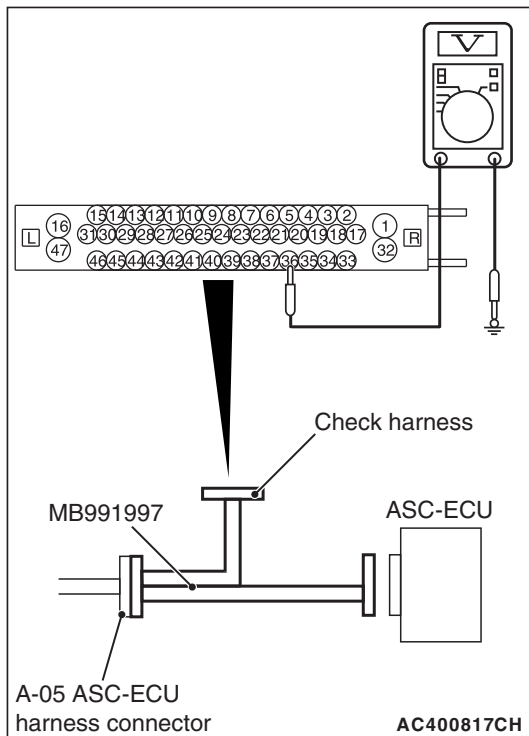

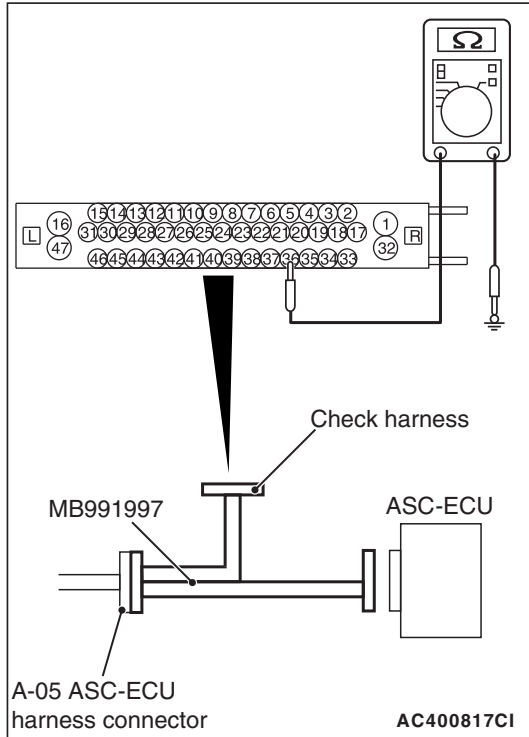

STEP 6. Resistance measurement at A-05 ASC-ECU connector

- (1) Disconnect the ASC-ECU connector, connect the special tool ASC check harness (MB991997) to the wiring harness-side connector, and then measure at the special tool connector side.

NOTE: Do not connect the special tool to ASC-ECU.

- (2) Measure the resistance between the wheel speed sensor circuit power supply terminal (signal terminal) No. 36 and the body ground as well as between the ground terminal No. 37 and the body ground.

OK: No continuity

Q: Is the check result normal?

YES : Go to Step 7.

NO (Not normal at the terminal No. 36 or 37) : Go to Step 8.

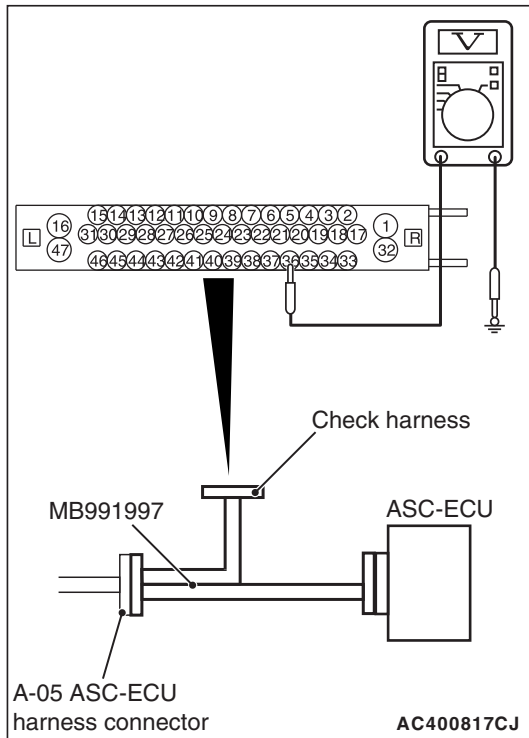

STEP 7. Voltage measurement at A-05 ASC-ECU connector

- (1) Disconnect the ASC-ECU connector, connect special tool ASC check harness (MB991997) to the ASC-ECU-side connector and the wiring harness-side connector, and then measure at the special tool connector side.
- (2) Turn the ignition switch to the ON position.
- (3) Measure the voltage between the wheel speed sensor circuit power supply terminal (signal terminal) No. 36 and the body ground and between the wheel speed sensor circuit ground terminal No. 37 and the body ground.

OK:

Terminal No.36 and the body ground: Battery positive voltage

Terminal No.37 and the body ground: 1 V or less

Q: Is the check result normal?

YES : Go to Step 8.

NO : Go to Step 10.

STEP 8. Check of wheel speed sensor as a single unit

Refer to [P.35C-303](#).

Q: Is the check result normal?

YES : Go to Step 9.

NO : Replace the wheel speed sensor <RL>. (Refer to [P.35C-300](#).) Then go to Step 11.

STEP 9. Wiring harness check between A-05 ASC-ECU connector terminal No. 36 and D-18 wheel speed sensor <RL> connector terminal No. 1, and between A-05 ASC-ECU connector terminal No. 37 and D-18 wheel speed sensor <RL> connector terminal No. 2

- Check for short or open circuit in wheel speed sensor <RL> circuit

Q: Is the check result normal?

YES : Go to Step 10.

NO : Repair the wiring harness. Then go to Step 11.

STEP 10. Check whether the DTC is reset.

- (1) Erase the DTC.
- (2) Drive the vehicle at 12mph (20 km/h) or more.

NOTE: The ABS warning light does not turn OFF in some cases unless the vehicle runs at 12mph (20 km/h) or higher.

Q: Is DTC C1020 set?

YES : Replace the hydraulic unit (incorporates in ASC-ECU).(Refer to [P.35C-298](#).) Then go to Step 11.

NO : Intermittent malfunction. (Refer to GROUP 00 –How to Cope with Intermittent Malfunction [P.00-15](#).)

STEP 11. Check whether the DTC is reset.

- (1) Erase the DTC.
- (2) Drive the vehicle at 12mph (20 km/h) or more.

NOTE: The ABS warning light does not turn OFF in some cases unless the vehicle runs at 12mph (20 km/h) or higher.

Q: Is DTC C1020 set?

YES : Return to Step 1.

NO : This diagnosis is complete.

DTC C102B: Abnormality in RR wheel speed sensor circuit

Wheel Speed Sensor Circuit

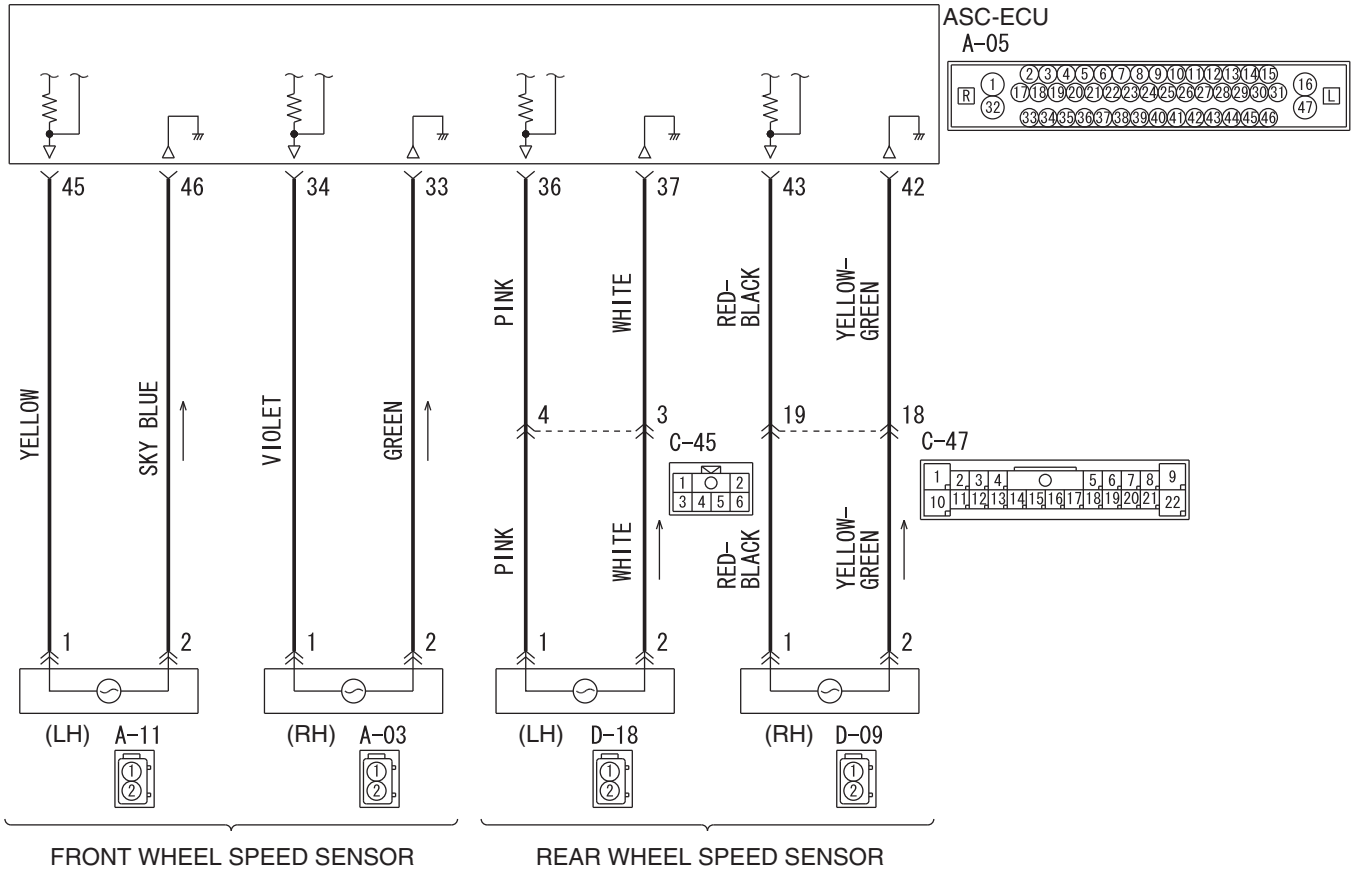

AC804587

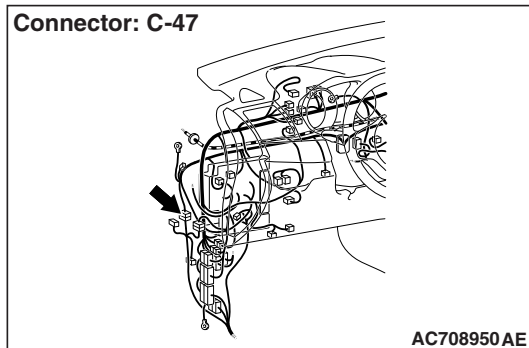
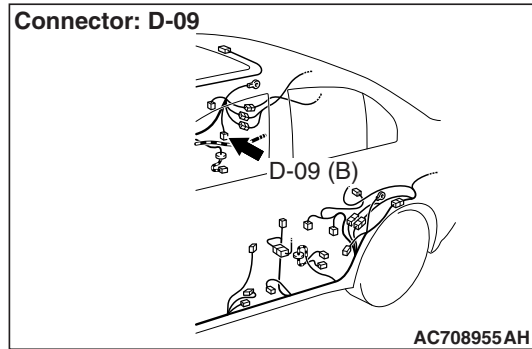
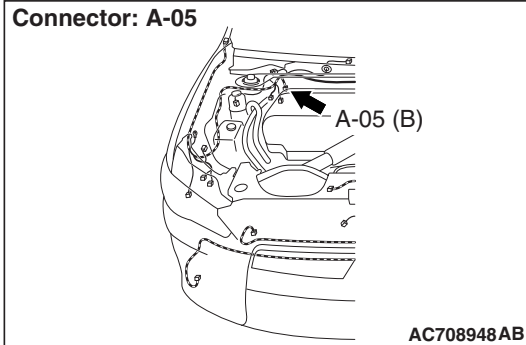

⚠ CAUTION

- If there is any problem in the CAN bus lines, an incorrect diagnostic trouble code may be set. Prior to this diagnosis, diagnose the CAN bus lines.
- Whenever the ECU is replaced, ensure that the CAN bus lines are normal.
- When the hydraulic unit (integrated with ASC-ECU) is replaced, always perform the calibration of steering wheel sensor, G and yaw rate sensor, brake fluid pressure sensor, cut valve, and inlet valve. (Refer to [P.35C-287](#), [P.35C-289](#), [P.35C-294](#), and [P.35C-295](#).)

CIRCUIT OPERATION

- Each wheel speed detecting section is a kind of a pulse generator. It consists of the encoder (plate on which the north and south pole of magnet are arranged alternately) for detecting the wheel speed, which rotates at the same speed of the wheels, and the wheel speed sensor. This detecting section outputs the frequency pulse signals in proportion to the wheel speed.
- The pulse signals generated by the wheel speed detecting section are sent to ASC-ECU. ASC-ECU uses the frequency of the pulse signals to determine the wheel speed.

DTC SET CONDITIONS

ASC-ECU monitors the electric current in each wheel speed sensor circuit. If an open or short circuit in the wheel speed sensor circuit is detected, ASC-ECU sets a corresponding diagnostic trouble code.

PROBABLE CAUSES**Current trouble**

- Damaged wiring harness and connectors
- Noise interference
- Malfunction of wheel speed sensor
- ASC-ECU malfunction

Past trouble

- Carry out the diagnosis with a particular emphasis on the wiring harness and connector failures between ASC-ECU and the wheel speed sensor. For diagnosis procedures, refer to How to Treat Past Trouble (GROUP 00 –How to Use Troubleshooting/Inspection Service Points [P.00-16](#)).

DIAGNOSIS**Required Special Tools:**

- MB991958 Scan Tool (M.U.T.-III Sub Assembly)
 - MB991824: Vehicle Communication Interface (V.C.I.)
 - MB991827 M.U.T.-III USB Cable
 - MB991910 M.U.T.-III Main Harness A
- MB991997: ASC check harness

STEP 1. Using scan tool MB991958, diagnose the CAN bus lines.

Using scan tool MB991958, diagnose the CAN bus lines.

Q: Is the check result normal?

YES : Go to Step 3.

NO : Repair the CAN bus lines (Refer to GROUP 54C – CAN Bus Diagnostics table P.54C-9). On completion, go to Step 2.

STEP 2. DTC recheck after repairing the CAN bus line**Q: Is DTC C102B set?**

YES : Go to Step 3.

NO : This diagnosis is complete.

STEP 3. Scan tool service data

Check the following service data. (Refer to P.35C-276.)

- Item No.04: RR wheel speed sensor

Q: Is the check result normal?

YES : Go to Step 10.

NO : Go to Step 4.

STEP 4. Connector check: A-05 ASC-ECU connector, C-47 intermediate connector, D-09 wheel speed sensor <RR> connector**Q: Is the check result normal?**

YES : Go to Step 5.

NO : Repair the defective connector. Then go to Step 11.

STEP 5. Voltage measurement at A-05 ASC-ECU connector

- (1) Disconnect the ASC-ECU connector, connect the special tool ASC check harness (MB991997) to the wiring harness-side connector, and then measure at the special tool connector side.

NOTE: Do not connect the special tool to ASC-ECU.

- (2) Turn the ignition switch to the ON position.
- (3) Measure the voltage between the wheel speed sensor power supply terminal (signal terminal) No. 43 and the body ground as well as between the ground terminal No. 42 and the body ground.

OK: 1 volt or less

Q: Is the check result normal?

YES : Go to Step 6.

NO (Not normal at the terminal No. 43 or 42) : Go to Step 8.

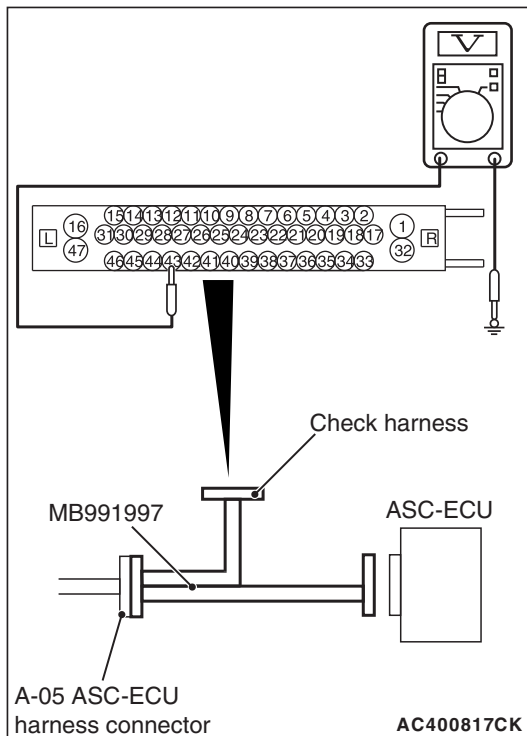

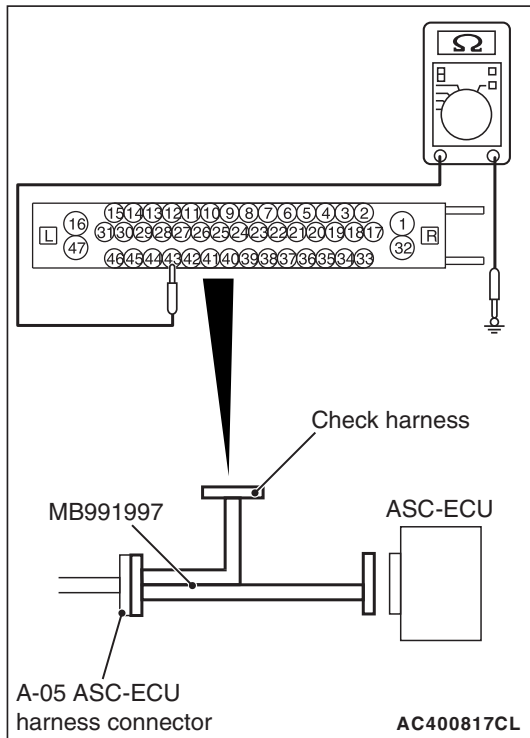

STEP 6. Resistance measurement at A-05 ASC-ECU connector

- (1) Disconnect the ASC-ECU connector, connect the special tool ASC check harness (MB991997) to the wiring harness-side connector, and then measure at the special tool connector side.

NOTE: Do not connect the special tool to ASC-ECU.

- (2) Measure the resistance between the wheel speed sensor circuit power supply terminal (signal terminal) No. 43 and the body ground as well as between the ground terminal No. 42 and the body ground.

OK: No continuity

Q: Is the check result normal?

YES : Go to Step 7.

NO (Not normal at the terminal No. 43 or 42) : Go to Step 8.

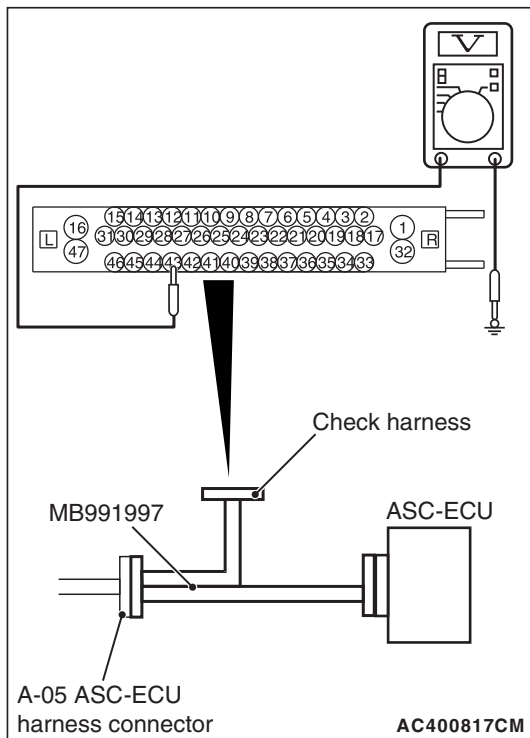

STEP 7. Voltage measurement at A-05 ASC-ECU connector

- (1) Disconnect the ASC-ECU connector, connect special tool ASC check harness (MB991997) to the ASC-ECU-side connector and the wiring harness-side connector, and then measure at the special tool connector side.
- (2) Turn the ignition switch to the ON position.
- (3) Measure the voltage between the wheel speed sensor circuit power supply terminal (signal terminal) No. 43 and the body ground and between the wheel speed sensor circuit ground terminal No. 42 and the body ground.

OK:

Terminal No.43 and the body ground: Battery positive voltage

Terminal No.42 and the body ground: 1 V or less

Q: Is the check result normal?

YES : Go to Step 8.

NO : Go to Step 10.

STEP 8. Check of wheel speed sensor as a single unit

Refer to [P.35C-303](#).

Q: Is the check result normal?

YES : Go to Step 9.

NO : Replace the wheel speed sensor <RR>. (Refer to [P.35C-300](#).) Then go to Step 11.

STEP 9. Wiring harness check between A-05 ASC-ECU connector terminal No. 43 and D-09 wheel speed sensor <RR> connector terminal No. 1, and between A-05 ASC-ECU connector terminal No. 42 and D-09 wheel speed sensor <RR> connector terminal No. 2

- Check for short or open circuit in wheel speed sensor <RR> circuit

Q: Is the check result normal?

YES : Go to Step 10.

NO : Repair the wiring harness. Then go to Step 11.

STEP 10. Check whether the DTC is reset.

- (1) Erase the DTC.
- (2) Drive the vehicle at 12mph (20 km/h) or more.

NOTE: The ABS warning light does not turn OFF in some cases unless the vehicle runs at 12mph (20 km/h) or higher.

Q: Is DTC C102B set?

YES : Replace the hydraulic unit (incorporates in ASC-ECU).(Refer to [P.35C-298](#).) Then go to Step 11.

NO : Intermittent malfunction. (Refer to GROUP 00 –How to Cope with Intermittent Malfunction [P.00-15](#).)

STEP 11. Check whether the DTC is reset.

- (1) Erase the DTC.
- (2) Drive the vehicle at 12mph (20 km/h) or more.

NOTE: The ABS warning light does not turn OFF in some cases unless the vehicle runs at 12mph (20 km/h) or higher.

Q: Is DTC C102B set?

YES : Return to Step 1.

NO : This diagnosis is complete.

DTC C1011: Abnormality in FL wheel speed sensor signal

Wheel Speed Sensor Circuit

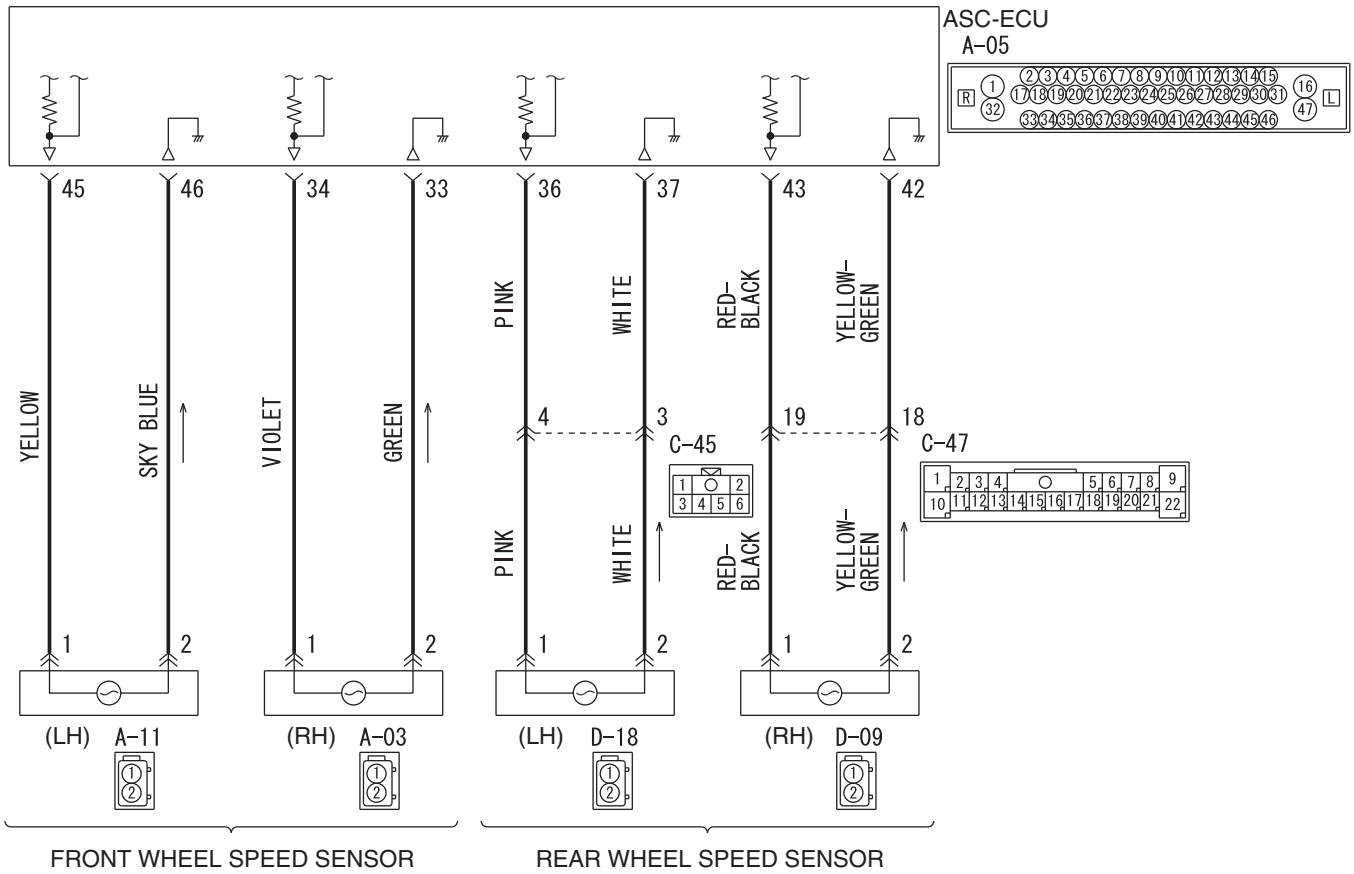

AC804587

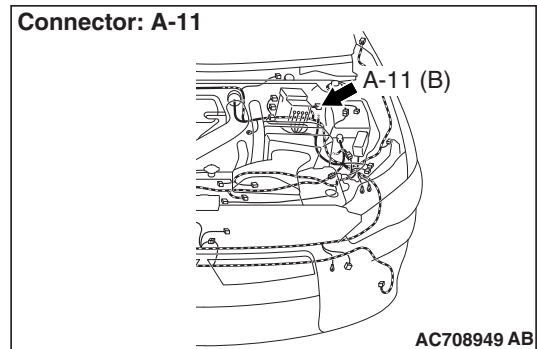
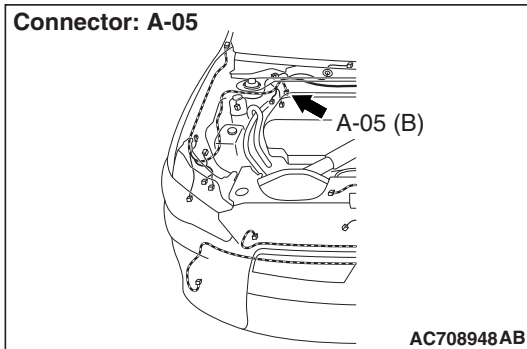

⚠ CAUTION

- If there is any problem in the CAN bus lines, an incorrect diagnostic trouble code may be set. Prior to this diagnosis, diagnose the CAN bus lines.
- Whenever the ECU is replaced, ensure that the CAN bus lines are normal.
- When the hydraulic unit (integrated with ASC-ECU) is replaced, always perform the calibration of steering wheel sensor, G and yaw rate sensor, brake fluid pressure sensor, cut valve, and inlet valve. (Refer to [P.35C-287](#), [P.35C-289](#), [P.35C-294](#), and [P.35C-295](#).)

CIRCUIT OPERATION

- Each wheel speed detecting section is a kind of a pulse generator. It consists of the encoder (plate on which the north and south pole of magnet are arranged alternately) for detecting the wheel speed, which rotates at the same speed of the wheels, and the wheel speed sensor. This detecting section outputs the frequency pulse signals in proportion to the wheel speed.
- The pulse signals generated by the wheel speed detecting section are sent to ASC-ECU. ASC-ECU uses the frequency of the pulse signals to determine the wheel speed.

DTC SET CONDITIONS

ASC-ECU monitors the signals from each wheel speed sensor while the vehicle is being driven. If any abnormality below is detected in the sensor signals, ASC-ECU sets the relevant diagnostic trouble code.

- Irregular change in the wheel speed sensor signal
- Wheel speed sensor signal continuously indicates higher value than the values of other wheel speed sensors.

PROBABLE CAUSES**Current trouble**

- Excessive gap between the wheel speed sensor and the magnetic encoder for wheel speed detection
- Adhesion of foreign materials on the wheel speed sensor
- Adhesion of foreign materials on the magnetic encoder for wheel speed detection
- Wheel bearing malfunction
- Malfunction of wheel speed sensor
- Damaged wiring harness and connectors
- External noise interference
- Improper installation of the wheel speed sensor
- Deformation of the magnetic encoder for wheel speed detection
- ASC-ECU malfunction
- Disturbance of magnetization pattern for magnetic encoder for wheel speed detection

- The number of poles on the magnetic encoder for wheel speed detection (the number of N-pole and S-pole) is changed.

Past trouble

- When the DTC No. C100A is also set, perform the diagnosis with a particular emphasis on the wiring harness and connector failures between ASC-ECU and the wheel speed sensor. For diagnosis procedures, refer to How to Treat Past Trouble (GROUP 00 –How to Use Troubleshooting/Inspection Service Points [P.00-16](#)).
- When the diagnostic trouble code No.C100A is not set, the following conditions may be present:
 - Wheel(s) spinning
 - Unstable vehicle attitude (spin)
 - External noise interference
 - Vehicle ran with the parking brake applied.

DIAGNOSIS

Required Special Tools:

- MB991958 Scan Tool (M.U.T.-III Sub Assembly)
 - MB991824: Vehicle Communication Interface (V.C.I.)
 - MB991827 M.U.T.-III USB Cable
 - MB991910 M.U.T.-III Main Harness A
- MB991997: ASC check harness

STEP 1. Using scan tool MB991958, diagnose the CAN bus lines.

Using scan tool MB991958, diagnose the CAN bus lines.

Q: Is the check result normal?

YES : Go to Step 3.

NO : Repair the CAN bus lines (Refer to GROUP 54C – CAN Bus Diagnostics table [P.54C-9](#)). On completion, go to Step 2.

STEP 2. DTC recheck after repairing the CAN bus line

Q: Is DTC C1011 set?

YES : Go to Step 3.

NO : This diagnosis is complete.

STEP 3. Scan tool diagnostic trouble code

Check if DTC No. C100A is also set.

Q: Is DTC C100A also set?

YES : Carry out the diagnosis for DTC C100A. (Refer to [P.35C-25](#).)

NO : Go to Step 4.

STEP 4. Check of wheel speed sensor installation status

Check the installation status of wheel speed sensor <FL> (disconnection of wheel speed sensor, looseness of mounting bolt, etc.).

Q: Is the check result normal?

YES : Go to Step 5.

NO : Reinstall the wheel speed sensor <FL> correctly. (Refer to [P.35C-300.](#)) Then go to Step 16.

STEP 5. Check of wheel speed sensor as a single unit

Refer to [P.35C-303.](#)

Q: Is the check result normal?

YES : Go to Step 6.

NO : Replace the wheel speed sensor <FL>. (Refer to [P.35C-300.](#)) Then go to Step 16.

STEP 6. Wheel bearing looseness check**NOTE:**

- Wheel bearing looseness may increase the gap between the wheel speed sensor and the wheel speed detection magnet encoder.
- Check the wheel bearing <FL> for looseness. (Refer to [GROUP 26 –On-vehicle Service P.26-7.](#))

Q: Is the check result normal?

YES : Go to Step 7.

NO : Replace the front hub assembly. (Refer to [GROUP 26 –Front Axle Hub Assembly P.26-9.](#)) Then go to Step 16.

STEP 7. Check of wheel speed detection encoder

Check the encoder for adhesion of foreign materials or deformation.

Q: Is the check result normal?

YES : Go to Step 8.

NO (Adhesion of foreign materials) : Clean the encoder so as not to disturb the magnetization pattern on the encoder while taking care of the magnet, magnetic substance, and magnetic attraction. Then go to Step 16 .

NO (Deformation) : Replace the front hub assembly. (Refer to [GROUP 26 –Front Axle Hub Assembly P.26-9.](#)) Then go to Step 16.

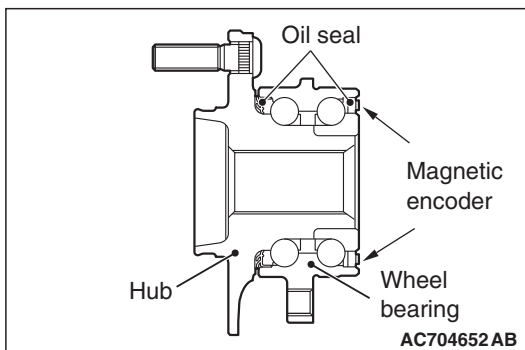

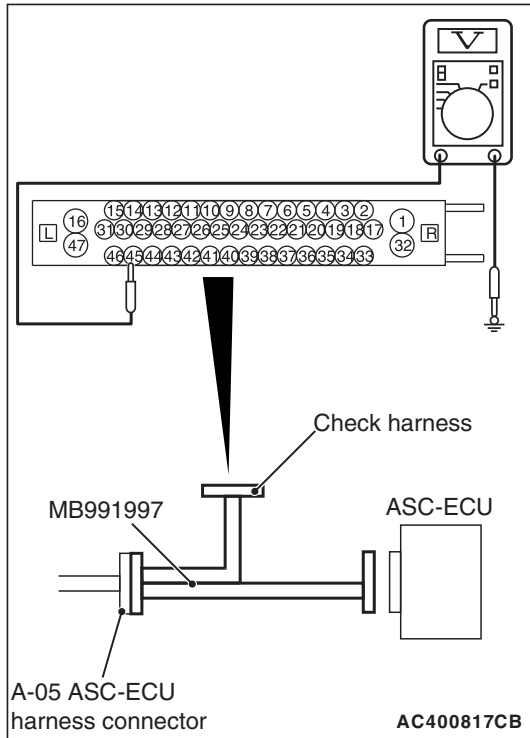

STEP 8. Voltage measurement at A-05 ASC-ECU connector

- (1) Disconnect the ASC-ECU connector, connect the special tool ASC check harness (MB991997) to the wiring harness-side connector, and then measure at the special tool connector side.

NOTE: Do not connect the special tool to ASC-ECU.

- (2) Turn the ignition switch to the ON position.
- (3) Measure the voltage between the wheel speed sensor circuit power supply terminal (signal terminal) No. 45 and the body ground as well as between the ground terminal No. 46 and the body ground.

OK: 1 volt or less

Q: Is the check result normal?

YES : Go to Step 9.

NO (Not normal at the terminal No. 45 or 46) : Go to Step 10.

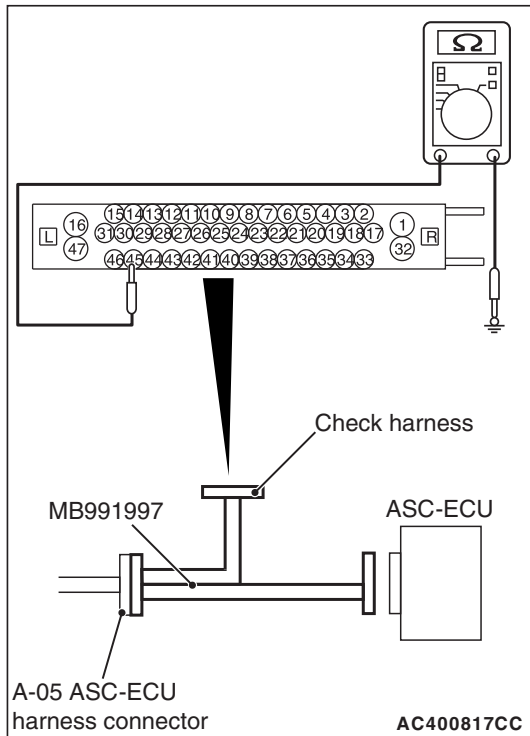

STEP 9. Resistance measurement at A-05 ASC-ECU connector

- (1) Disconnect the ASC-ECU connector, connect the special tool ASC check harness (MB991997) to the wiring harness-side connector, and then measure at the special tool connector side.

NOTE: Do not connect the special tool to ASC-ECU.

- (2) Measure the resistance between the wheel speed sensor circuit power supply terminal (signal terminal) No. 45 and the body ground as well as between the ground terminal No. 46 and the body ground.

OK: No continuity

Q: Is the check result normal?

YES : Go to Step 12.

NO (Not normal at the terminal No. 45 or 46) : Go to Step 10.

STEP 10. Connector check: A-05 ASC-ECU connector, A-11 wheel speed sensor <FL> connector

Q: Is the check result normal?

YES : Go to Step 11.

NO : Repair the defective connector. Then go to Step 16.

STEP 11. Wiring harness check between A-05 ASC-ECU connector terminal No. 45 and A-11 wheel speed sensor <FL> connector terminal No. 1, and between A-05 ASC-ECU connector terminal No. 46 and A-11 wheel speed sensor <FL> connector terminal No. 2

- Check for short circuit in wheel speed sensor <FL> circuit

Q: Is the check result normal?

YES : Replace the wheel speed sensor <FL>. (Refer to [P.35C-300.](#)) Then, go to Step 16.

NO : Repair the wiring harness. Then go to Step 16.

STEP 12. Voltage measurement at A-05 ASC-ECU connector

- (1) Disconnect the ASC-ECU connector, connect the special tool ASC check harness (MB991997) to the ASC-ECU-side connector and the wiring harness-side connector, and then measure at the special tool connector side.
- (2) Turn the ignition switch to the ON position.
- (3) Measure the voltage between the wheel speed sensor circuit power supply terminal (signal terminal) No. 45 and the body ground.

OK: Battery positive voltage

Q: Is the check result normal?

YES : Go to Step 13.

NO : Go to Step 15.

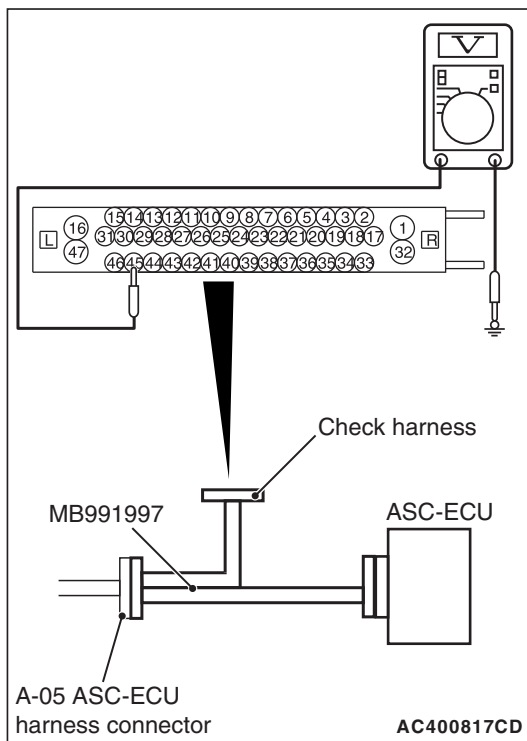

STEP 13. Connector check: A-05 ASC-ECU connector, A-11 wheel speed sensor <FL> connector

Q: Is the check result normal?

YES : Go to Step 14.

NO : Repair the defective connector. Then go to Step 16.

STEP 14. Wiring harness check between A-05 ASC-ECU connector terminal No. 45 and A-11 wheel speed sensor <FL> connector terminal No. 1, and between A-05 ASC-ECU connector terminal No. 46 and A-11 wheel speed sensor <FL> connector terminal No. 2

- Open circuit check of wheel speed sensor <FL> circuit

Q: Is the check result normal?

YES : Go to Step 15.

NO : Repair the wiring harness. Then go to Step 16.

STEP 15. Check whether the DTC is reset.

- (1) Erase the DTC.
- (2) Drive the vehicle at 12mph (20 km/h) or more.

NOTE: The ABS warning light does not turn OFF in some cases unless the vehicle runs at 12mph (20 km/h) or higher.

Q: Is DTC C1011 set?

YES : Replace the hydraulic unit (incorporates in ASC-ECU).(Refer to [P.35C-298.](#)) Then go to Step 16.

NO : Intermittent malfunction. (Refer to GROUP 00 –How to Cope with Intermittent Malfunction [P.00-15.](#))

STEP 16. Check whether the DTC is reset.

- (1) Erase the DTC.
- (2) Drive the vehicle at 12mph (20 km/h) or more.

NOTE: The ABS warning light does not turn OFF in some cases unless the vehicle runs at 12mph (20 km/h) or higher.

Q: Is DTC C1011 set?

YES : Return to Step 1.

NO : This diagnosis is complete.

DTC C101C: Abnormality in FR wheel speed sensor signal

Wheel Speed Sensor Circuit

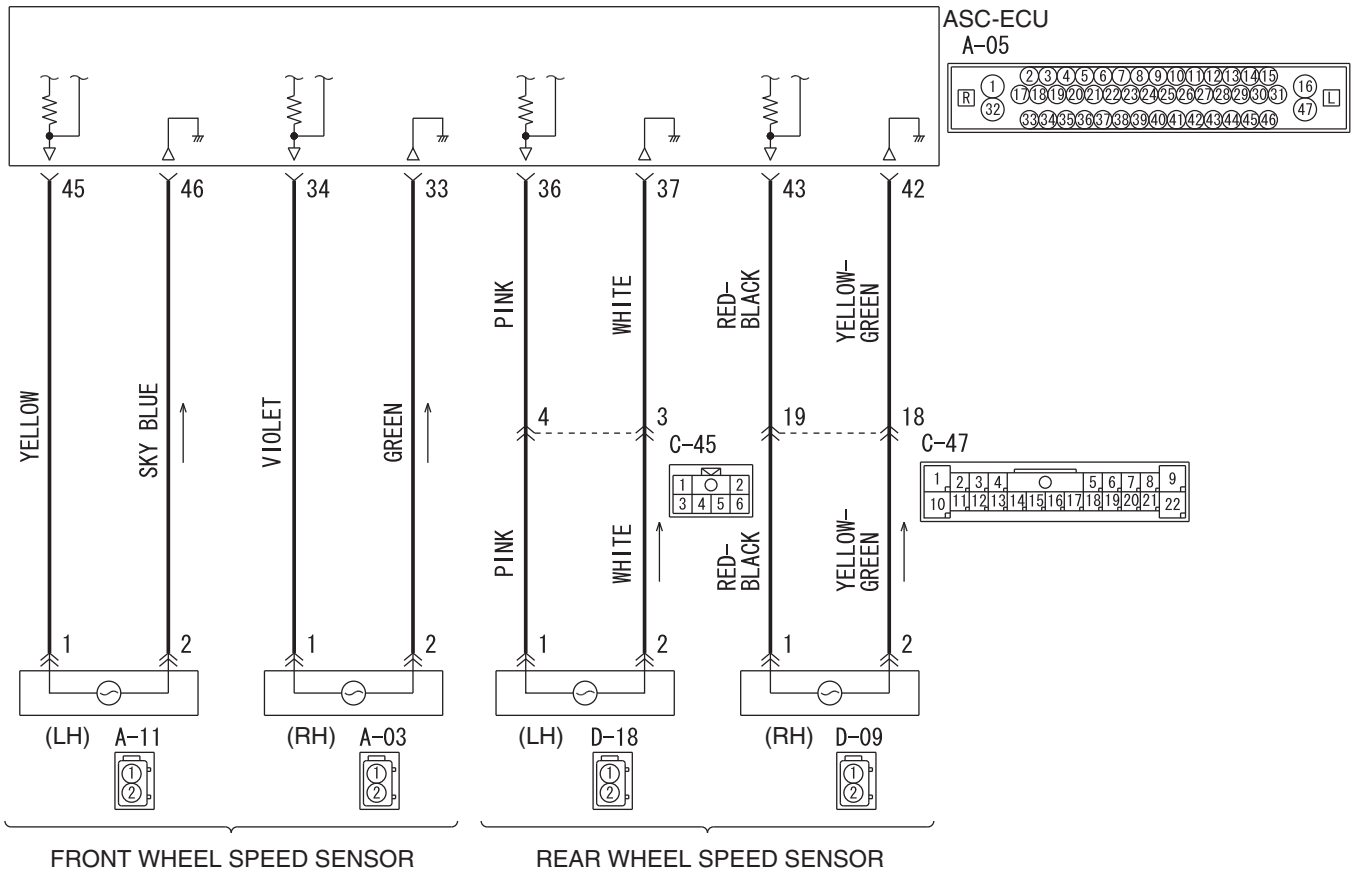

AC804587

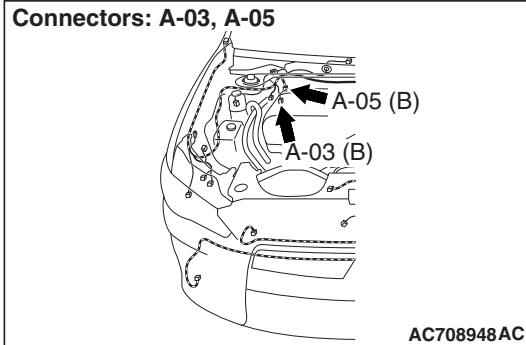

⚠ CAUTION

- If there is any problem in the CAN bus lines, an incorrect diagnostic trouble code may be set. Prior to this diagnosis, diagnose the CAN bus lines.
- Whenever the ECU is replaced, ensure that the CAN bus lines are normal.
- When the hydraulic unit (integrated with ASC-ECU) is replaced, always perform the calibration of steering wheel sensor, G and yaw rate sensor, brake fluid pressure sensor, cut valve, and inlet valve.(Refer to [P.35C-287](#), [P.35C-289](#), [P.35C-294](#), and [P.35C-295](#).)

CIRCUIT OPERATION

- Each wheel speed detecting section is a kind of a pulse generator. It consists of the encoder (plate on which the north and south pole of magnet are arranged alternately) for detecting the wheel speed, which rotates at the same speed of the wheels, and the wheel speed sensor. This detecting section outputs the frequency pulse signals in proportion to the wheel speed.
- The pulse signals generated by the wheel speed detecting section are sent to ASC-ECU. ASC-ECU uses the frequency of the pulse signals to determine the wheel speed.

DTC SET CONDITIONS

ASC-ECU monitors the signals from each wheel speed sensor while the vehicle is being driven. If any abnormality below is detected in the sensor signals, ASC-ECU sets the relevant diagnostic trouble code.

- Irregular change in the wheel speed sensor signal
- Wheel speed sensor signal continuously indicates higher value than the values of other wheel speed sensors.

PROBABLE CAUSES**Current trouble**

- Excessive gap between the wheel speed sensor and the magnetic encoder for wheel speed detection
- Adhesion of foreign materials on the wheel speed sensor
- Adhesion of foreign materials on the magnetic encoder for wheel speed detection
- Wheel bearing malfunction
- Malfunction of wheel speed sensor
- Damaged wiring harness and connectors
- External noise interference
- Improper installation of the wheel speed sensor
- Deformation of the magnetic encoder for wheel speed detection
- ASC-ECU malfunction
- Disturbance of magnetization pattern for magnetic encoder for wheel speed detection

- The number of poles on the magnetic encoder for wheel speed detection (the number of N-pole and S-pole) is changed.

Past trouble

- When the DTC No. C1015 is also set, perform the diagnosis with a particular emphasis on the wiring harness and connector failures between ASC-ECU and the wheel speed sensor. For diagnosis procedures, refer to How to Treat Past Trouble (GROUP 00 –How to Use Troubleshooting/Inspection Service Points [P.00-16](#)).
- When diagnostic trouble code No.C1015 is not set, the following conditions may be present:
 - Wheel(s) spinning
 - Unstable vehicle attitude (spin)
 - External noise interference
 - Vehicle ran with the parking brake applied.

DIAGNOSIS**Required Special Tools:**

- MB991958 Scan Tool (M.U.T.-III Sub Assembly)
 - MB991824: Vehicle Communication Interface (V.C.I.)
 - MB991827 M.U.T.-III USB Cable
 - MB991910 M.U.T.-III Main Harness A
- MB991997: ASC check harness

STEP 1. Using scan tool MB991958, diagnose the CAN bus lines.

Using scan tool MB991958, diagnose the CAN bus lines.

Q: Is the check result normal?

YES : Go to Step 3.

NO : Repair the CAN bus lines (Refer to GROUP 54C – CAN Bus Diagnostics Table [P.54C-9](#)). On completion, go to Step 2.

STEP 2. DTC recheck after repairing the CAN bus line**Q: Is DTC C101C set?**

YES : Go to Step 3.

NO : This diagnosis is complete.

STEP 3. Scan tool diagnostic trouble code

Check if DTC No. C1015 is also set.

Q: Is DTC C1015 also set?

YES : Carry out the diagnosis for DTC C1015. (Refer to [P.35C-25](#).)

NO : Go to Step 4.

STEP 4. Check of wheel speed sensor installation status

Check the installation status of wheel speed sensor <FR> (disconnection of wheel speed sensor, looseness of mounting bolt, etc.).

Q: Is the check result normal?

YES : Go to Step 5.

NO : Reinstall the wheel speed sensor <FR> correctly. (Refer to [P.35C-300.](#)) Then go to Step 16.

STEP 5. Check of wheel speed sensor as a single unit

Refer to [P.35C-303.](#)

Q: Is the check result normal?

YES : Go to Step 6.

NO : Replace the wheel speed sensor <FR>. (Refer to [P.35C-300.](#)) Then go to Step 16.

STEP 6. Wheel bearing looseness check

NOTE:

- Wheel bearing looseness may increase the gap between the wheel speed sensor and the wheel speed detection magnet encoder.
- Check the wheel bearing <FR> for looseness. (Refer to **GROUP 26 –On-vehicle Service** [P.26-7.](#))

Q: Is the check result normal?

YES : Go to Step 7.

NO : Replace the front hub assembly. (Refer to **GROUP 26 –Front Axle Hub Assembly** [P.26-9.](#)) Then go to Step 16.

STEP 7. Check of wheel speed detection encoder

Check the encoder for adhesion of foreign materials or deformation.

Q: Is the check result normal?

YES : Go to Step 8.

NO (Adhesion of foreign materials) : Clean the encoder so as not to disturb the magnetization pattern on the encoder while taking care of the magnet, magnetic substance, and magnetic attraction. Then go to Step 16 .

NO (Deformation) : Replace the front hub assembly. (Refer to **GROUP 26 –Front Axle Hub Assembly** [P.26-9.](#)) Then go to Step 16.

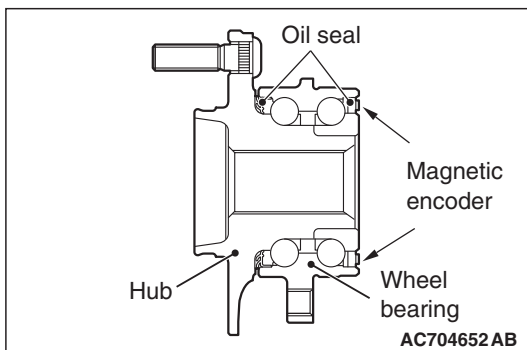

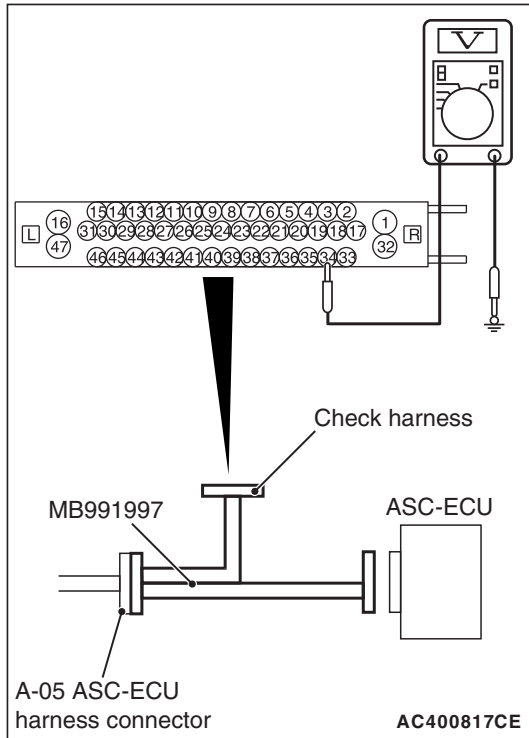
**STEP 8. Voltage measurement at A-05 ASC-ECU connector**

- (1) Disconnect the ASC-ECU connector, connect the special tool ASC check harness (MB991997) to the wiring harness-side connector, and then measure at the special tool connector side.

NOTE: Do not connect the special tool to ASC-ECU.

- (2) Turn the ignition switch to the ON position.
- (3) Measure the voltage between the wheel speed sensor circuit power supply terminal (signal terminal) No. 34 and the body ground as well as between the ground terminal No. 33 and the body ground.

OK: 1 volt or less

Q: Is the check result normal?

YES : Go to Step 9.

NO (Not normal at the terminal No. 34 or 33) : Go to Step 10.

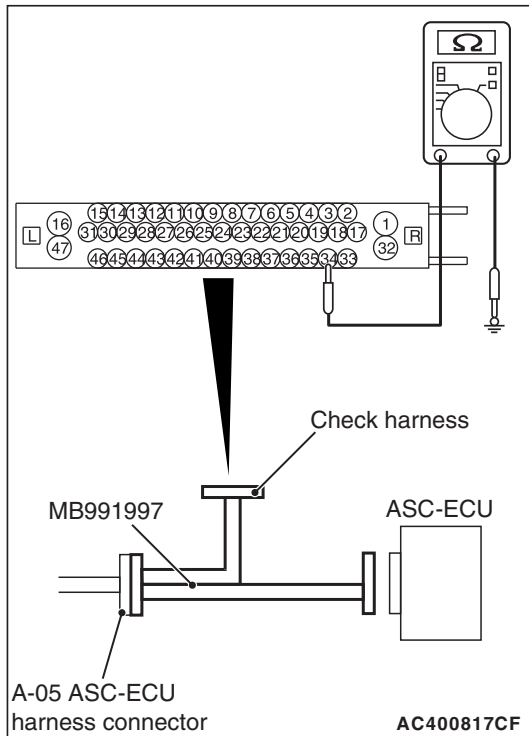
**STEP 9. Resistance measurement at A-05 ASC-ECU connector**

- (1) Disconnect the ASC-ECU connector, connect the special tool ASC check harness (MB991997) to the wiring harness-side connector, and then measure at the special tool connector side.

NOTE: Do not connect the special tool to ASC-ECU.

- (2) Measure the resistance between the wheel speed sensor circuit power supply terminal (signal terminal) No. 34 and the body ground as well as between the ground terminal No. 33 and the body ground.

OK: No continuity

Q: Is the check result normal?

YES : Go to Step 12.

NO (Not normal at the terminal No. 34 or 33) : Go to Step 10.

STEP 10. Connector check: A-05 ASC-ECU connector, A-03 wheel speed sensor <FR> connector

Q: Is the check result normal?

YES : Go to Step 11.

NO : Repair the defective connector. Then go to Step 16.

STEP 11. Wiring harness check between A-05 ASC-ECU connector terminal No. 34 and A-03 wheel speed sensor <FR> connector terminal No. 1, and between A-05 ASC-ECU connector terminal No. 33 and A-03 wheel speed sensor <FR> connector terminal No. 2

- Check for short circuit in wheel speed sensor <FR> circuit

Q: Is the check result normal?

YES : Replace the wheel speed sensor <FR>. (Refer to [P.35C-300.](#)) Then, go to Step 16.

NO : Repair the wiring harness. Then go to Step 16.

STEP 12. Voltage measurement at A-05 ASC-ECU connector

- (1) Disconnect the ASC-ECU connector, connect the special tool ASC check harness (MB991997) to the ASC-ECU-side connector and the wiring harness-side connector, and then measure at the special tool connector side.
- (2) Turn the ignition switch to the ON position.
- (3) Measure the voltage between the wheel speed sensor circuit power supply terminal (signal terminal) No. 34 and the body ground.

OK: Battery positive voltage

Q: Is the check result normal?

YES : Go to Step 13.

NO : Go to Step 15.

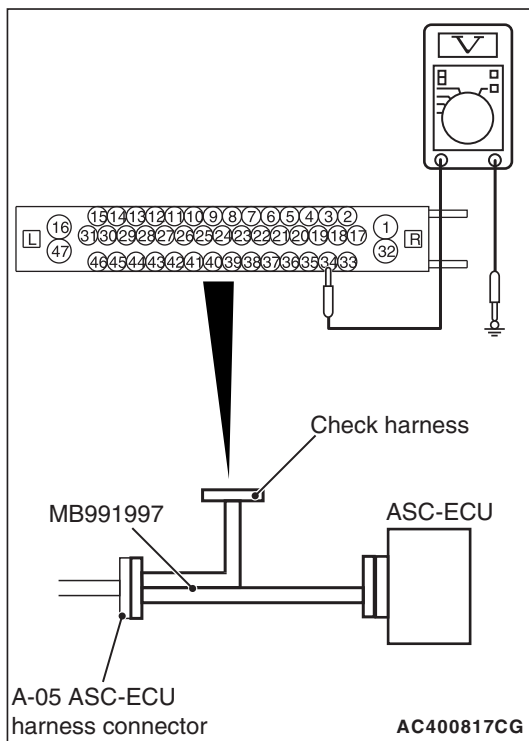

STEP 13. Connector check: A-05 ASC-ECU connector, A-03 wheel speed sensor <FR> connector

Q: Is the check result normal?

YES : Go to Step 14.

NO : Repair the defective connector. Then go to Step 16.

STEP 14. Wiring harness check between A-05 ASC-ECU connector terminal No. 34 and A-03 wheel speed sensor <FR> connector terminal No. 1, and between A-05 ASC-ECU connector terminal No. 33 and A-03 wheel speed sensor <FR> connector terminal No. 2

- Open circuit check of wheel speed sensor <FR> circuit

Q: Is the check result normal?

YES : Go to Step 15.

NO : Repair the wiring harness. Then go to Step 16.

STEP 15. Check whether the DTC is reset.

- (1) Erase the DTC.
- (2) Drive the vehicle at 12mph (20 km/h) or more.

NOTE: The ABS warning light does not turn OFF in some cases unless the vehicle runs at 12mph (20 km/h) or higher.

Q: Is DTC C101C set?

YES : Replace the hydraulic unit (incorporates in ASC-ECU).(Refer to [P.35C-298](#).) Then go to Step 16.

NO : Intermittent malfunction. (Refer to GROUP 00 –How to Cope with Intermittent Malfunction [P.00-15](#).)

STEP 16. Check whether the DTC is reset.

- (1) Erase the DTC.
- (2) Drive the vehicle at 12mph (20 km/h) or more.

NOTE: The ABS warning light does not turn OFF in some cases unless the vehicle runs at 12mph (20 km/h) or higher.

Q: Is DTC C101C set?

YES : Return to Step 1.

NO : This diagnosis is complete.

DTC C1027: Abnormality in RL wheel speed sensor signal

Wheel Speed Sensor Circuit

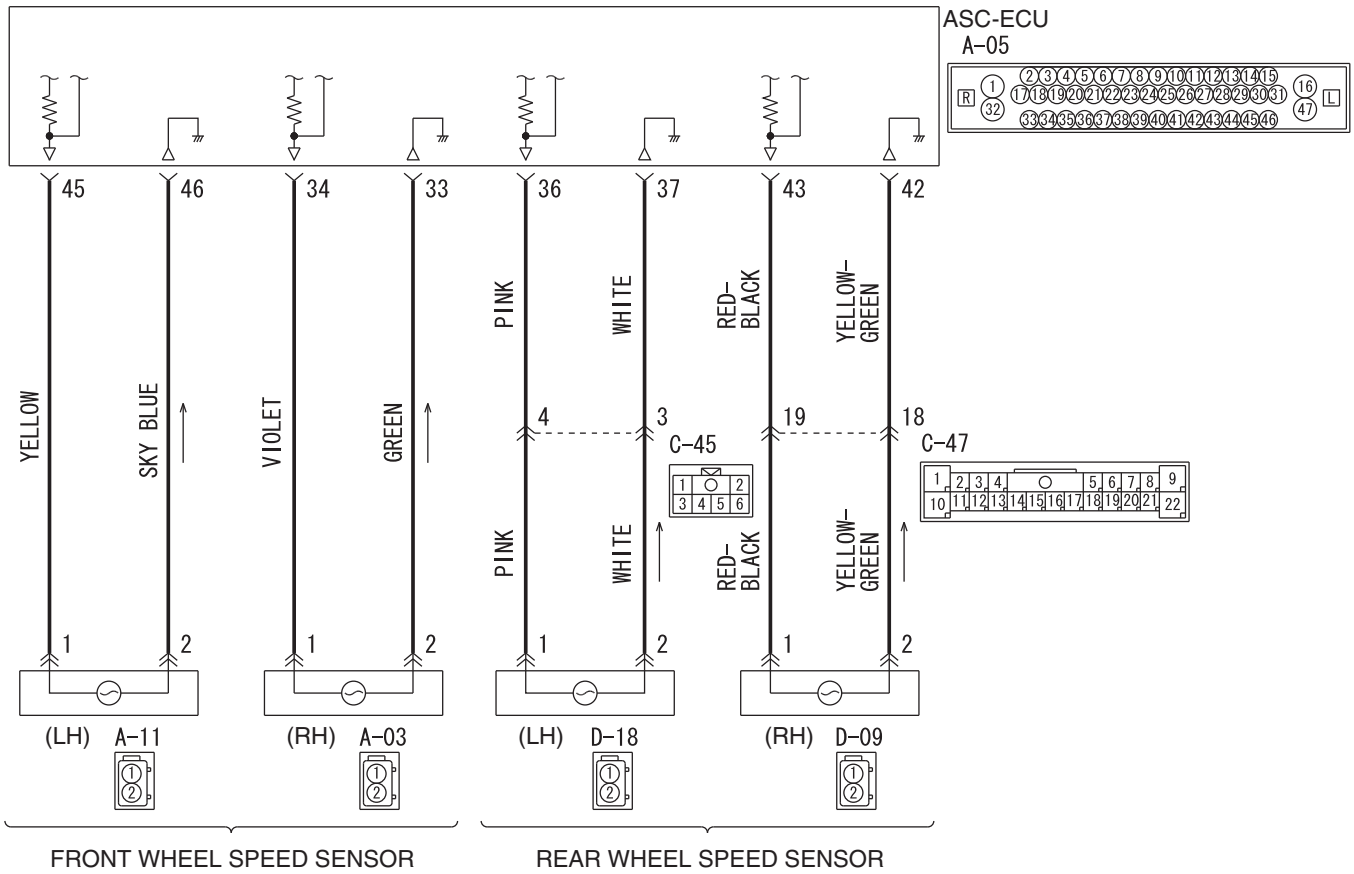

AC804587

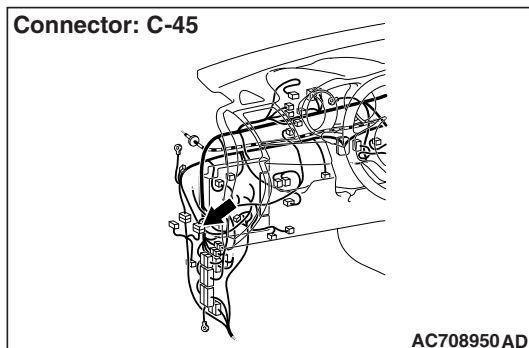
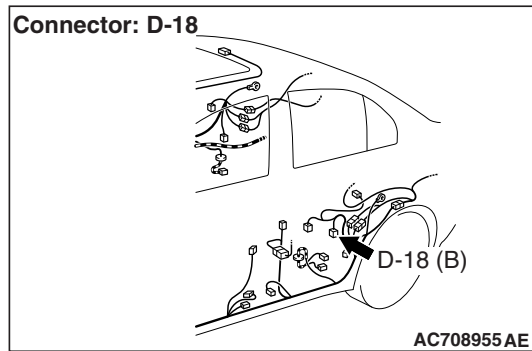
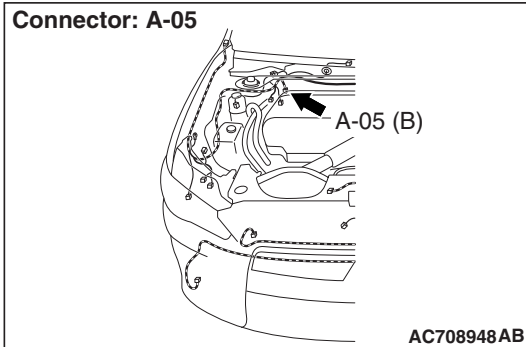

⚠ CAUTION

- If there is any problem in the CAN bus lines, an incorrect diagnostic trouble code may be set. Prior to this diagnosis, diagnose the CAN bus lines.
- Whenever the ECU is replaced, ensure that the CAN bus lines are normal.
- When the hydraulic unit (integrated with ASC-ECU) is replaced, always perform the calibration of steering wheel sensor, G and yaw rate sensor, brake fluid pressure sensor, cut valve, and inlet valve.(Refer to [P.35C-287](#), [P.35C-289](#), [P.35C-294](#), and [P.35C-295](#).)

CIRCUIT OPERATION

- Each wheel speed detecting section is a kind of a pulse generator. It consists of the encoder (plate on which the north and south pole of magnet are arranged alternately) for detecting the wheel speed, which rotates at the same speed of the wheels, and the wheel speed sensor. This detecting section outputs the frequency pulse signals in proportion to the wheel speed.
- The pulse signals generated by the wheel speed detecting section are sent to ASC-ECU. ASC-ECU uses the frequency of the pulse signals to determine the wheel speed.

DTC SET CONDITIONS

ASC-ECU monitors the signals from each wheel speed sensor while the vehicle is being driven. If any abnormality below is detected in the sensor signals, ASC-ECU sets the relevant diagnostic trouble code.

- Irregular change in the wheel speed sensor signal
- Wheel speed sensor signal continuously indicates higher value than the values of other wheel speed sensors.

PROBABLE CAUSES**Current trouble**

- Excessive gap between the wheel speed sensor and the magnetic encoder for wheel speed detection
- Adhesion of foreign materials on the wheel speed sensor
- Adhesion of foreign materials on the magnetic encoder for wheel speed detection
- Wheel bearing malfunction
- Malfunction of wheel speed sensor
- Damaged wiring harness and connectors
- External noise interference
- Improper installation of the wheel speed sensor
- Deformation of the magnetic encoder for wheel speed detection
- ASC-ECU malfunction
- Disturbance of magnetization pattern for magnetic encoder for wheel speed detection

- The number of poles on the magnetic encoder for wheel speed detection (the number of N-pole and S-pole) is changed.

Past trouble

- When DTC No. C1020 is also set, perform the diagnosis with a particular emphasis on the wiring harness and connector failures between ASC-ECU and the wheel speed sensor. For diagnosis procedures, refer to How to Treat Past Trouble (GROUP 00 –How to Use Troubleshooting/Inspection Service Points [P.00-16](#)).
- When the diagnostic trouble code No.C1020 is not set, the following conditions may be present:
 - Wheel(s) spinning
 - Unstable vehicle attitude (spin)
 - External noise interference
 - Vehicle ran with the parking brake applied.

DIAGNOSIS

Required Special Tools:

- MB991958 Scan Tool (M.U.T.-III Sub Assembly)
 - MB991824: Vehicle Communication Interface (V.C.I.)
 - MB991827 M.U.T.-III USB Cable
 - MB991910 M.U.T.-III Main Harness A
- MB991997: ASC check harness

STEP 1. Using scan tool MB991958, diagnose the CAN bus lines.

Using scan tool MB991958, diagnose the CAN bus lines.

Q: Is the check result normal?

YES : Go to Step 3.

NO : Repair the CAN bus lines (Refer to GROUP 54C – CAN Bus Diagnostics Table [P.54C-9](#)). On completion, go to Step 2.

STEP 2. DTC recheck after repairing the CAN bus line

Q: Is DTC C1027 set?

YES : Go to Step 3.

NO : This diagnosis is complete.

STEP 3. Scan tool diagnostic trouble code

Check if DTC No. C1020 is also set.

Q: Is DTC C1020 also set?

YES : Carry out the diagnosis for DTC C1020. (Refer to [P.35C-25](#).)

NO : Go to Step 4.

STEP 4. Check of wheel speed sensor installation status

Check the installation status of wheel speed sensor <RL> (disconnection of wheel speed sensor, looseness of mounting bolt, etc.).

Q: Is the check result normal?

YES : Go to Step 5.

NO : Reinstall the wheel speed sensor <RL> correctly. (Refer to [P.35C-300.](#)) Then go to Step 16.

STEP 5. Check of wheel speed sensor as a single unit

Refer to [P.35C-303.](#)

Q: Is the check result normal?

YES : Go to Step 6.

NO : Replace the wheel speed sensor <RL>. (Refer to [P.35C-300.](#)) Then go to Step 16.

STEP 6. Wheel bearing looseness check**NOTE:**

- Wheel bearing looseness may increase the gap between the wheel speed sensor and the wheel speed detection magnet encoder.
- Check the wheel bearing <RL> for looseness. (Refer to [GROUP 27 –On-vehicle Service P.27-32.](#))

Q: Is the check result normal?

YES : Go to Step 7.

NO : Replace the rear wheel hub assembly. (Refer to [GROUP 27 –Rear Axle Hub Assembly P.27-35.](#))

STEP 7. Check of wheel speed detection encoder

Check the encoder for adhesion of foreign materials or deformation.

Q: Is the check result normal?

YES : Go to Step 8.

NO (Adhesion of foreign materials) : Clean the encoder so as not to disturb the magnetization pattern on the encoder while taking care of the magnet, magnetic substance, and magnetic attraction. Then go to Step 16 .

NO (Deformation) : Replace the rear wheel hub assembly. (Refer to [GROUP 27 –Rear Axle Hub Assembly P.27-35.](#)) Then go to Step 16.

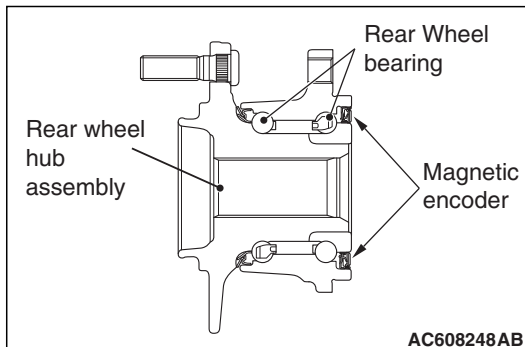

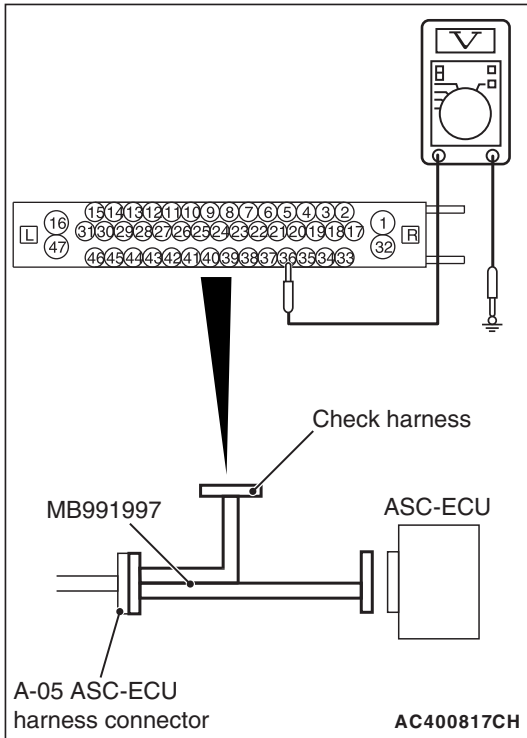

STEP 8. Voltage measurement at A-05 ASC-ECU connector

- (1) Disconnect the ASC-ECU connector, connect the special tool ASC check harness (MB991997) to the wiring harness-side connector, and then measure at the special tool connector side.

NOTE: Do not connect the special tool to ASC-ECU.

- (2) Turn the ignition switch to the ON position.
- (3) Measure the voltage between the wheel speed sensor circuit power supply terminal (signal terminal) No. 36 and the body ground as well as between the ground terminal No. 37 and the body ground.

OK: 1 volt or less

Q: Is the check result normal?

YES : Go to Step 9.

NO (Not normal at the terminal No. 36 or 37) : Go to Step 10.

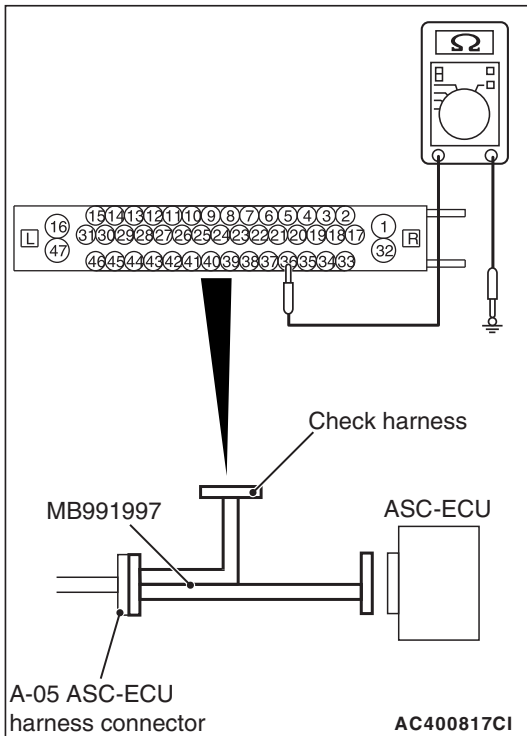

STEP 9. Resistance measurement at A-05 ASC-ECU connector

- (1) Disconnect the ASC-ECU connector, connect the special tool ASC check harness (MB991997) to the wiring harness-side connector, and then measure at the special tool connector side.

NOTE: Do not connect the special tool to ASC-ECU.

- (2) Measure the resistance between the wheel speed sensor circuit power supply terminal (signal terminal) No. 36 and the body ground as well as between the ground terminal No. 37 and the body ground.

OK: No continuity

Q: Is the check result normal?

YES : Go to Step 12.

NO (Not normal at the terminal No. 36 or 37) : Go to Step 10.

STEP 10. Connector check: A-05 ASC-ECU connector, C-45 intermediate connector, D-18 wheel speed sensor <RL> connector

Q: Is the check result normal?

YES : Go to Step 11.

NO : Repair the defective connector. Then go to Step 16.

STEP 11. Wiring harness check between A-05 ASC-ECU connector terminal No. 36 and D-18 wheel speed sensor <RL> connector terminal No. 1, and between A-05 ASC-ECU connector terminal No. 37 and D-18 wheel speed sensor <RL> connector terminal No. 2

- Check for short circuit in wheel speed sensor <RL> circuit

Q: Is the check result normal?

YES : Replace the wheel speed sensor <RL>. (Refer to [P.35C-300.](#)) Then, go to Step 16.

NO : Repair the wiring harness. Then go to Step 16.

STEP 12. Voltage measurement at A-05 ASC-ECU connector

- (1) Disconnect the ASC-ECU connector, connect the special tool ASC check harness (MB991997) to the ASC-ECU-side connector and the wiring harness-side connector, and then measure at the special tool connector side.
- (2) Turn the ignition switch to the ON position.
- (3) Measure the voltage between the wheel speed sensor circuit power supply terminal (signal terminal) No. 36 and the body ground.

OK: Battery positive voltage

Q: Is the check result normal?

YES : Go to Step 13.

NO : Go to Step 15.

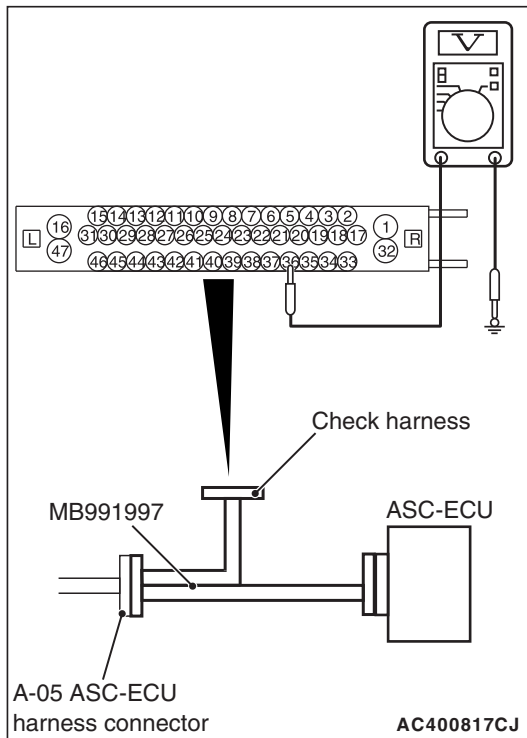

STEP 13. Connector check: A-05 ASC-ECU connector, C-45 intermediate connector, D-18 wheel speed sensor <RL> connector

Q: Is the check result normal?

YES : Go to Step 14.

NO : Repair the defective connector. Then go to Step 16.

STEP 14. Wiring harness check between A-05 ASC-ECU connector terminal No. 36 and D-18 wheel speed sensor <RL> connector terminal No. 1, and between A-05 ASC-ECU connector terminal No. 37 and D-18 wheel speed sensor <RL> connector terminal No. 2

- Open circuit check of wheel speed sensor <RL> circuit

Q: Is the check result normal?

YES : Go to Step 15.

NO : Repair the wiring harness. Then go to Step 16.

STEP 15. Check whether the DTC is reset.

- (1) Erase the DTC.
- (2) Drive the vehicle at 12mph (20 km/h) or more.

NOTE: The ABS warning light does not turn OFF in some cases unless the vehicle runs at 12mph (20 km/h) or higher.

Q: Is DTC C1027 set?

YES : Replace the hydraulic unit (incorporates in ASC-ECU).(Refer to [P.35C-298.](#)) Then go to Step 16.

NO : Intermittent malfunction. (Refer to GROUP 00 –How to Cope with Intermittent Malfunction [P.00-15.](#))

STEP 16. Check whether the DTC is reset.

- (1) Erase the DTC.
- (2) Drive the vehicle at 12mph (20 km/h) or more.

NOTE: The ABS warning light does not turn OFF in some cases unless the vehicle runs at 12mph (20 km/h) or higher.

Q: Is DTC C1027 set?

YES : Return to Step 1.

NO : This diagnosis is complete.

DTC C1032: Abnormality in RR wheel speed sensor signal

Wheel Speed Sensor Circuit

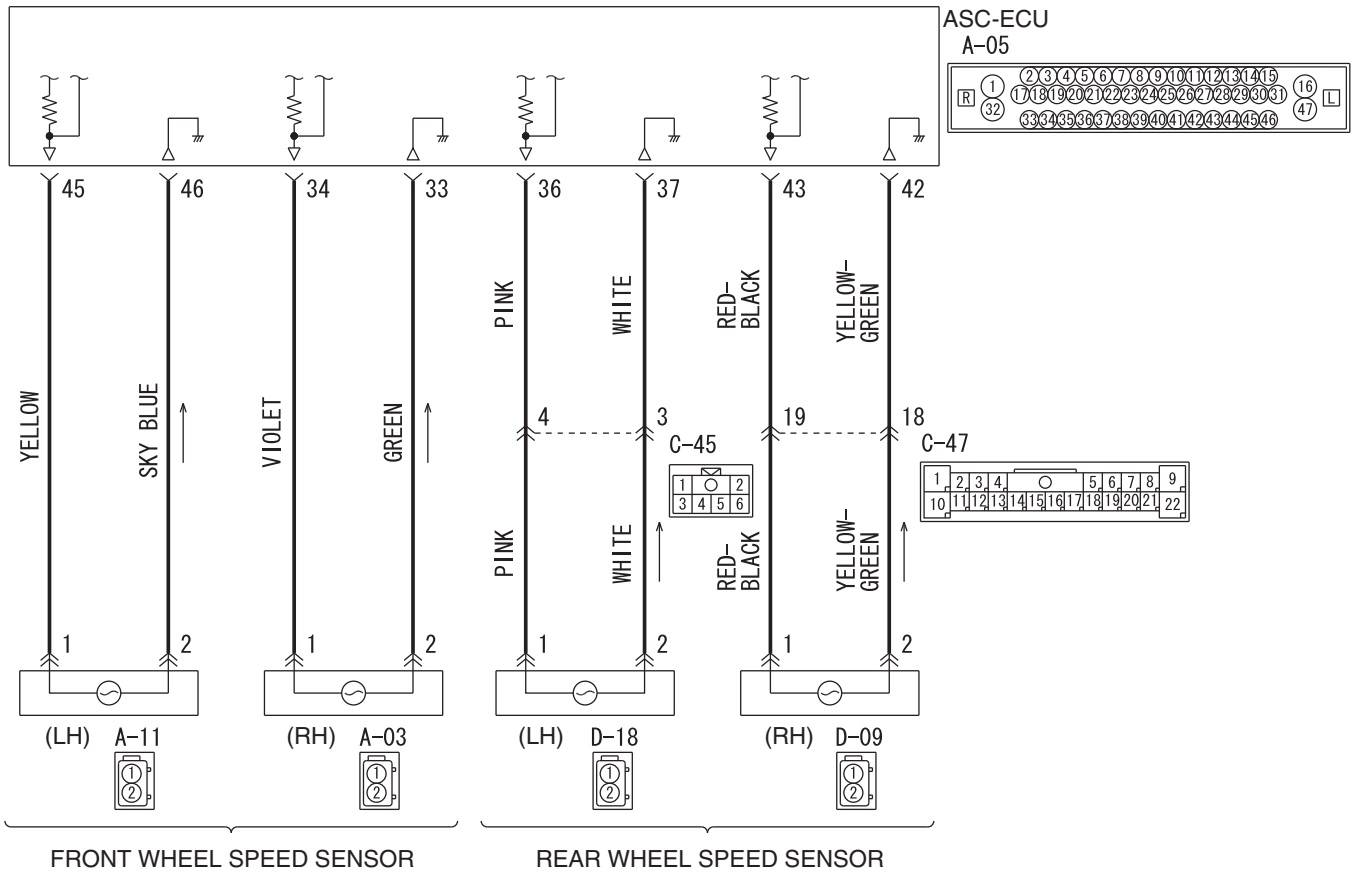

AC804587

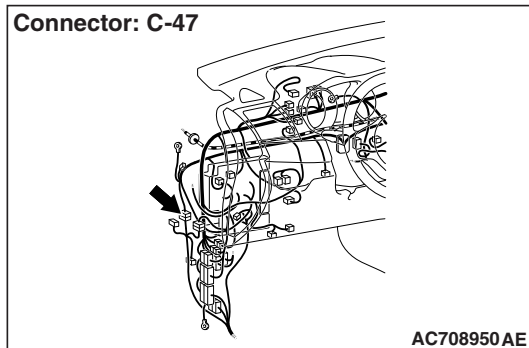
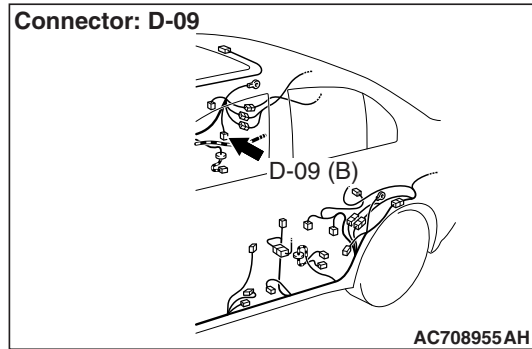
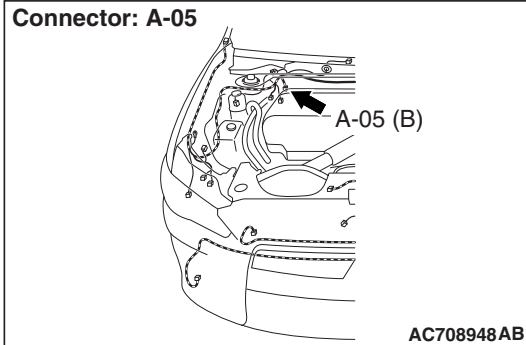

⚠ CAUTION

- If there is any problem in the CAN bus lines, an incorrect diagnostic trouble code may be set. Prior to this diagnosis, diagnose the CAN bus lines.
- Whenever the ECU is replaced, ensure that the CAN bus lines are normal.
- When the hydraulic unit (integrated with ASC-ECU) is replaced, always perform the calibration of steering wheel sensor, G and yaw rate sensor, brake fluid pressure sensor, cut valve, and inlet valve.(Refer to [P.35C-287](#), [P.35C-289](#), [P.35C-294](#), and [P.35C-295](#).)

CIRCUIT OPERATION

- Each wheel speed detecting section is a kind of a pulse generator. It consists of the encoder (plate on which the north and south pole of magnet are arranged alternately) for detecting the wheel speed, which rotates at the same speed of the wheels, and the wheel speed sensor. This detecting section outputs the frequency pulse signals in proportion to the wheel speed.
- The pulse signals generated by the wheel speed detecting section are sent to ASC-ECU. ASC-ECU uses the frequency of the pulse signals to determine the wheel speed.

DTC SET CONDITIONS

ASC-ECU monitors the signals from each wheel speed sensor while the vehicle is being driven. If any abnormality below is detected in the sensor signals, ASC-ECU sets the relevant diagnostic trouble code.

- Irregular change in the wheel speed sensor signal
- Wheel speed sensor signal continuously indicates higher value than the values of other wheel speed sensors.

PROBABLE CAUSES**Current trouble**

- Excessive gap between the wheel speed sensor and the magnetic encoder for wheel speed detection
- Adhesion of foreign materials on the wheel speed sensor
- Adhesion of foreign materials on the magnetic encoder for wheel speed detection
- Wheel bearing malfunction
- Malfunction of wheel speed sensor
- Damaged wiring harness and connectors
- External noise interference
- Improper installation of the wheel speed sensor
- Deformation of the magnetic encoder for wheel speed detection
- ASC-ECU malfunction
- Disturbance of magnetization pattern for magnetic encoder for wheel speed detection

- The number of poles on the magnetic encoder for wheel speed detection (the number of N-pole and S-pole) is changed.

Past trouble

- When DTC No. C102B is also set, perform the diagnosis with a particular emphasis on the wiring harness and connector failures between ASC-ECU and the wheel speed sensor. For diagnosis procedures, refer to How to Treat Past Trouble (GROUP 00 –How to Use Troubleshooting/Inspection Service Points [P.00-16](#)).
- When the diagnostic trouble code No.C102B is not set, the following conditions may be present:
 - Wheel(s) spinning
 - Unstable vehicle attitude (spin)
 - External noise interference
 - Vehicle ran with the parking brake applied.

DIAGNOSIS**Required Special Tools:**

- MB991958 Scan Tool (M.U.T.-III Sub Assembly)
 - MB991824: Vehicle Communication Interface (V.C.I.)
 - MB991827 M.U.T.-III USB Cable
 - MB991910 M.U.T.-III Main Harness A
- MB991997: ASC check harness

STEP 1. Using scan tool MB991958, diagnose the CAN bus lines.

Using scan tool MB991958, diagnose the CAN bus lines.

Q: Is the check result normal?

YES : Go to Step 3.

NO : Repair the CAN bus lines (Refer to GROUP 54C – CAN Bus Diagnostics Table [P.54C-9](#)). On completion, go to Step 2.

STEP 2. DTC recheck after repairing the CAN bus line**Q: Is DTC C1032 set?**

YES : Go to Step 3.

NO : This diagnosis is complete.

STEP 3. Scan tool diagnostic trouble code

Check if DTC No. C102B is also set.

Q: Is DTC C102B also set?

YES : Carry out the diagnosis for DTC C102B. (Refer to [P.35C-25](#).)

NO : Go to Step 4.

STEP 4. Check of wheel speed sensor installation status

Check the installation status of wheel speed sensor <RR> (disconnection of wheel speed sensor, looseness of mounting bolt, etc.).

Q: Is the check result normal?

YES : Go to Step 5.

NO : Reinstall the wheel speed sensor <RR> correctly. (Refer to [P.35C-300.](#)) Then go to Step 16.

STEP 5. Check of wheel speed sensor as a single unit

Refer to [P.35C-303.](#)

Q: Is the check result normal?

YES : Go to Step 6.

NO : Replace the wheel speed sensor <RR>. (Refer to [P.35C-300.](#)) Then go to Step 16.

STEP 6. Wheel bearing looseness check

NOTE:

- Wheel bearing looseness may increase the gap between the wheel speed sensor and the wheel speed detection magnet encoder.
- Check the wheel bearing <RR> for looseness. (Refer to [GROUP 27 –On-vehicle Service P.27-32.](#))

Q: Is the check result normal?

YES : Go to Step 7.

NO : Replace the rear wheel hub assembly. (Refer to [GROUP 27 –Rear Axle Hub Assembly P.27-35.](#))

STEP 7. Check of wheel speed detection encoder

Check the encoder for adhesion of foreign materials or deformation.

Q: Is the check result normal?

YES : Go to Step 8.

NO (Adhesion of foreign materials) : Clean the encoder so as not to disturb the magnetization pattern on the encoder while taking care of the magnet, magnetic substance, and magnetic attraction. Then go to Step 16 .

NO (Deformation) : Replace the rear wheel hub assembly. (Refer to [GROUP 27 –Rear Axle Hub Assembly P.27-35.](#)) Then go to Step 16.

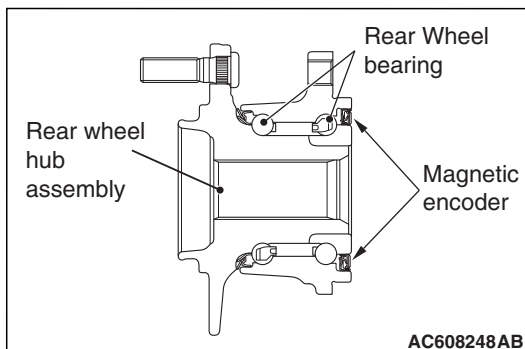

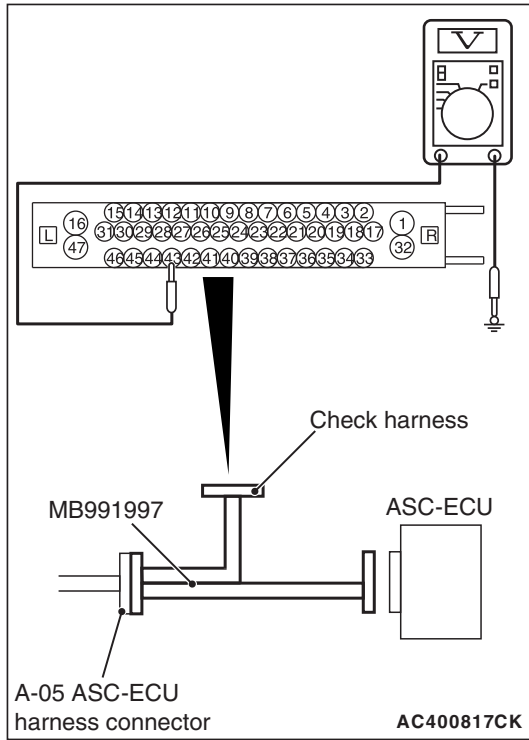

STEP 8. Voltage measurement at A-05 ASC-ECU connector

- (1) Disconnect the ASC-ECU connector, connect the special tool ASC check harness (MB991997) to the wiring harness-side connector, and then measure at the special tool connector side.

NOTE: Do not connect the special tool to ASC-ECU.

- (2) Turn the ignition switch to the ON position.
- (3) Measure the voltage between the wheel speed sensor circuit power supply terminal (signal terminal) No. 43 and the body ground as well as between the ground terminal No. 42 and the body ground.

OK: 1 volt or less

Q: Is the check result normal?

YES : Go to Step 9.

NO (Not normal at the terminal No. 43 or 42) : Go to Step 10.

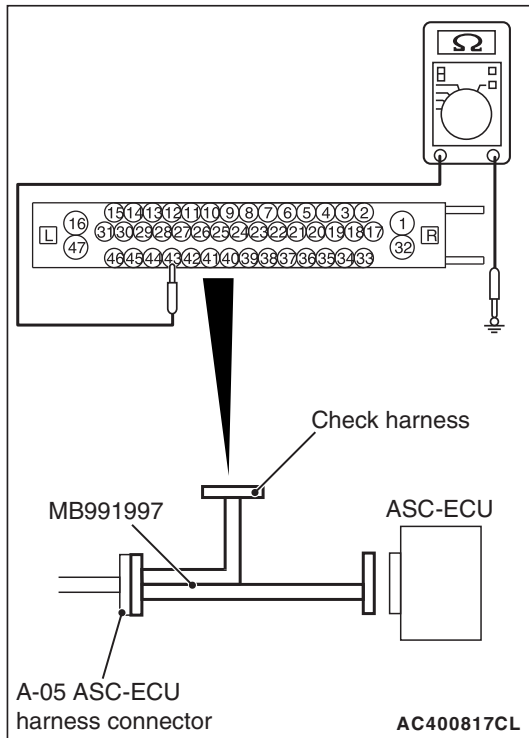

STEP 9. Resistance measurement at A-05 ASC-ECU connector

- (1) Disconnect the ASC-ECU connector, connect the special tool ASC check harness (MB991997) to the wiring harness-side connector, and then measure at the special tool connector side.

NOTE: Do not connect the special tool to ASC-ECU.

- (2) Measure the resistance between the wheel speed sensor circuit power supply terminal (signal terminal) No. 43 and the body ground as well as between the ground terminal No. 42 and the body ground.

OK: No continuity

Q: Is the check result normal?

YES : Go to Step 12.

NO (Not normal at the terminal No. 43 or 42) : Go to Step 10.

STEP 10. Connector check: A-05 ASC-ECU connector, C-47 intermediate connector, D-09 wheel speed sensor <RR> connector

Q: Is the check result normal?

YES : Go to Step 11.

NO : Repair the defective connector. Then go to Step 16.

STEP 11. Wiring harness check between A-05 ASC-ECU connector terminal No. 43 and D-09 wheel speed sensor <RR> connector terminal No. 1, and between A-05 ASC-ECU connector terminal No. 42 and D-09 wheel speed sensor <RR> connector terminal No. 2

- Check for short circuit in wheel speed sensor <RR> circuit

Q: Is the check result normal?

YES : Replace the wheel speed sensor <RR>. (Refer to P.35C-300.) Then, go to Step 16.

NO : Repair the wiring harness. Then go to Step 16.

STEP 12. Voltage measurement at A-05 ASC-ECU connector

- (1) Disconnect the ASC-ECU connector, connect the special tool ASC check harness (MB991997) to the ASC-ECU-side connector and the wiring harness-side connector, and then measure at the special tool connector side.
- (2) Turn the ignition switch to the ON position.
- (3) Measure the voltage between the wheel speed sensor circuit power supply terminal (signal terminal) No. 43 and the body ground.

OK: Battery positive voltage

Q: Is the check result normal?

YES : Go to Step 13.

NO : Go to Step 15.

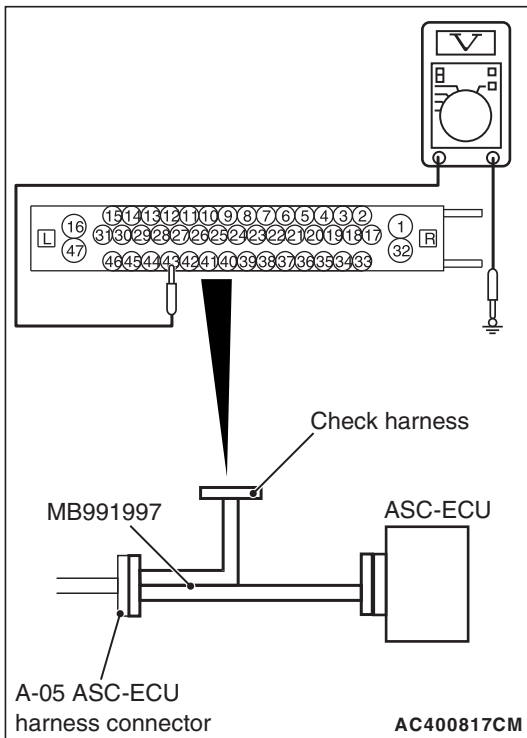

STEP 13. Connector check: A-05 ASC-ECU connector, C-47 intermediate connector, D-09 wheel speed sensor <RR> connector

Q: Is the check result normal?

YES : Go to Step 14.

NO : Repair the defective connector. Then go to Step 16.

STEP 14. Wiring harness check between A-05 ASC-ECU connector terminal No. 43 and D-09 wheel speed sensor <RR> connector terminal No. 1, and between A-05 ASC-ECU connector terminal No. 42 and D-09 wheel speed sensor <RR> connector terminal No. 2

- Open circuit check of wheel speed sensor <RR> circuit

Q: Is the check result normal?

YES : Go to Step 15.

NO : Repair the wiring harness. Then go to Step 16.

STEP 15. Check whether the DTC is reset.

(1) Erase the DTC.

(2) Drive the vehicle at 12mph (20 km/h) or more.

NOTE: The ABS warning light does not turn OFF in some cases unless the vehicle runs at 12mph (20 km/h) or higher.

Q: Is DTC C1032 set?

YES : Replace the hydraulic unit (incorporates in ASC-ECU).(Refer to [P.35C-298](#).) Then go to Step 16.

NO : Intermittent malfunction. (Refer to GROUP 00 –How to Cope with Intermittent Malfunction [P.00-15](#).)

STEP 16. Check whether the DTC is reset.

(1) Erase the DTC.

(2) Drive the vehicle at 12mph (20 km/h) or more.

NOTE: The ABS warning light does not turn OFF in some cases unless the vehicle runs at 12mph (20 km/h) or higher.

Q: Is DTC C1032 set?

YES : Return to Step 1.

NO : This diagnosis is complete.

DTC C1014: Mutual monitoring of FL wheel speed sensor

 **CAUTION**

- If there is any problem in the CAN bus lines, an incorrect diagnostic trouble code may be set. Prior to this diagnosis, diagnose the CAN bus lines.
- Whenever the ECU is replaced, ensure that the CAN bus lines are normal.
- When the hydraulic unit (integrated with ASC-ECU) is replaced, always perform the calibration of steering wheel sensor, G and yaw rate sensor, brake fluid pressure sensor, cut valve, and inlet valve.(Refer to [P.35C-287](#), [P.35C-289](#), [P.35C-294](#), and [P.35C-295](#).)

CIRCUIT OPERATION

- Each wheel speed detecting section is a kind of a pulse generator. It consists of the encoder (plate on which the north and south pole of magnet are arranged alternately) for detecting the wheel speed, which rotates at the same speed of the wheels, and the wheel speed sensor. This detecting section outputs the frequency pulse signals in proportion to the wheel speed.
- The pulse signals generated by the wheel speed detecting section are sent to ASC-ECU. ASC-ECU uses the frequency of the pulse signals to determine the wheel speed.

DTC SET CONDITIONS

ASC-ECU monitors the signals from each wheel speed sensor while the vehicle is being driven. If any abnormality below is detected in the sensor signals, ASC-ECU sets the relevant diagnostic trouble code.

- Missing wheel speed sensor signal
- Wheel speed sensor signal continuously indicates lower value than the values of other wheel speed sensors.

PROBABLE CAUSES

Current trouble

- Excessive gap between the wheel speed sensor and the magnetic encoder for wheel speed detection
- Wheel bearing malfunction
- Deformation of the magnetic encoder for wheel speed detection
- Adhesion of foreign materials on the wheel speed sensor
- Adhesion of foreign materials on the magnetic encoder for wheel speed detection
- Malfunction of wheel speed sensor
- Improper installation of the wheel speed sensor
- ASC-ECU malfunction
- Disturbance of magnetization pattern for magnetic encoder for wheel speed detection
- The number of poles on the magnetic encoder for wheel speed detection (the number of N-pole and S-pole) is changed.

Past trouble

- When the DTC No. C100A is also set, perform the diagnosis with a particular emphasis on the wiring harness and connector failures between ASC-ECU and the wheel speed sensor. For diagnosis procedures, refer to How to Treat Past Trouble (GROUP 00 –How to Use Troubleshooting/Inspection Service Points [P.00-16](#)).
- When DTC No. C100A is not set simultaneously, the followings can be suspected.
 - Wheel(s) spinning
 - Unstable vehicle attitude (spin)
 - External noise interference
 - Vehicle ran with the parking brake applied.
 - Only two wheels are rotated on a drum tester.

DIAGNOSIS**Required Special Tools:**

- MB991958 Scan Tool (M.U.T.-III Sub Assembly)
 - MB991824: Vehicle Communication Interface (V.C.I.)
 - MB991827 M.U.T.-III USB Cable
 - MB991910 M.U.T.-III Main Harness A
- MB991997: ASC check harness

STEP 1. Using scan tool MB991958, diagnose the CAN bus lines.

Using scan tool MB991958, diagnose the CAN bus lines.

Q: Is the check result normal?

YES : Go to Step 3.

NO : Repair the CAN bus lines. (Refer to GROUP 54C – Troubleshooting [P.54C-15](#).) After repairing the CAN bus line, go to Step 2.

STEP 2. DTC recheck after repairing the CAN bus line**Q: Is DTC C1014 set?**

YES : Go to Step 3.

NO : This diagnosis is complete.

STEP 3. Scan tool diagnostic trouble code

Check if DTC No. C100A is also set.

Q: Is DTC C100A also set?

YES : Carry out the diagnosis for code No. C100A. (Refer to [P.35C-25](#).)

NO : Go to Step 4.

STEP 4. Check of wheel speed sensor installation status

Check the installation status of wheel speed sensor <FL> (disconnection of wheel speed sensor, looseness of mounting bolt, etc.).

Q: Is the check result normal?

YES : Go to Step 5.

NO : Reinstall the wheel speed sensor <FL> correctly. (Refer to [P.35C-300](#).) Then go to Step 9.

STEP 5. Check of wheel speed sensor as a single unit

Refer to [P.35C-303](#).

Q: Is the check result normal?

YES : Go to Step 6.

NO : Replace the wheel speed sensor <FL>. (Refer to [P.35C-300](#).) Then go to Step 9.

STEP 6. Wheel bearing looseness check

NOTE: Wheel bearing looseness may increase the gap between the wheel speed sensor and the wheel speed detection magnet encoder. Check the wheel bearing <FL> for looseness. (Refer to GROUP 26 –On-vehicle Service P.26-7.)

Q: Is the check result normal?

YES : Go to Step 7.

NO : Replace the front hub assembly. (Refer to GROUP 26 –Front Axle Hub Assembly P.26-9.)

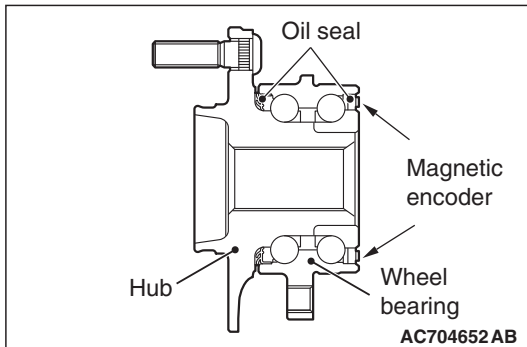

STEP 7. Check of wheel speed detection encoder

Check the encoder for adhesion of foreign materials or deformation.

Q: Is the check result normal?

YES : Go to Step 8.

NO (Adhesion of foreign materials) : Clean the encoder so as not to disturb the magnetization pattern on the encoder while taking care of the magnet, magnetic substance, and magnetic attraction.

NO (Deformation) : Replace the front hub assembly. (Refer to GROUP 26 –Front Axle Hub Assembly P.26-9.)

STEP 8. Check whether the DTC is reset.

- (1) Erase the diagnostic trouble code.
- (2) Drive the vehicle at 12mph (20 km/h) or more.

NOTE: The ABS warning light does not turn OFF in some cases unless the vehicle runs at 12mph (20 km/h) or higher.

Q: Is DTC C1014 set?

YES : Replace the hydraulic unit (incorporates in ASC-ECU).(Refer to P.35C-298.) Then go to Step 9.

NO : Intermittent malfunction. (Refer to GROUP 00 –How to Cope with Intermittent Malfunction P.00-15.)

STEP 9. Check whether the DTC is reset.

- (1) Erase the diagnostic trouble code.
- (2) Drive the vehicle at 12mph (20 km/h) or more.

NOTE: The ABS warning light does not turn OFF in some cases unless the vehicle runs at 12mph (20 km/h) or higher.

Q: Is DTC C1014 set?

YES : Return to Step 1.

NO : This diagnosis is complete.

DTC C101F: Mutual monitoring of FR wheel speed sensor

⚠ CAUTION

- If there is any problem in the CAN bus lines, an incorrect diagnostic trouble code may be set. Prior to this diagnosis, diagnose the CAN bus lines.
- Whenever the ECU is replaced, ensure that the CAN bus lines are normal.
- When the hydraulic unit (integrated with ASC-ECU) is replaced, always perform the calibration of steering wheel sensor, G and yaw rate sensor, brake fluid pressure sensor, cut valve, and inlet valve.(Refer to [P.35C-287](#), [P.35C-289](#), [P.35C-294](#), and [P.35C-295](#).)

CIRCUIT OPERATION

- Each wheel speed detecting section is a kind of a pulse generator. It consists of the encoder (plate on which the north and south pole of magnet are arranged alternately) for detecting the wheel speed, which rotates at the same speed of the wheels, and the wheel speed sensor. This detecting section outputs the frequency pulse signals in proportion to the wheel speed.
- The pulse signals generated by the wheel speed detecting section are sent to ASC-ECU. ASC-ECU uses the frequency of the pulse signals to determine the wheel speed.

DTC SET CONDITIONS

ASC-ECU monitors the signals from each wheel speed sensor while the vehicle is being driven. If any abnormality below is detected in the sensor signals, ASC-ECU sets the relevant diagnostic trouble code.

- Missing wheel speed sensor signal
- Wheel speed sensor signal continuously indicates lower value than the values of other wheel speed sensors.

PROBABLE CAUSES**Current trouble**

- Excessive gap between the wheel speed sensor and the magnetic encoder for wheel speed detection
- Wheel bearing malfunction
- Deformation of the magnetic encoder for wheel speed detection
- Adhesion of foreign materials on the wheel speed sensor
- Adhesion of foreign materials on the magnetic encoder for wheel speed detection
- Malfunction of wheel speed sensor
- Improper installation of the wheel speed sensor
- ABS-ECU malfunction
- Disturbance of magnetization pattern for magnetic encoder for wheel speed detection

- The number of poles on the magnetic encoder for wheel speed detection (the number of N-pole and S-pole) is changed.

Past trouble

- When the DTC No. C1015 is also set, perform the diagnosis with a particular emphasis on the wiring harness and connector failures between ASC-ECU and the wheel speed sensor. For diagnosis procedures, refer to How to Treat Past Trouble (GROUP 00 –How to Use Troubleshooting/Inspection Service Points [P.00-16](#)).
- When DTC No. C1015 is not set simultaneously, the followings can be suspected.
 - Wheel(s) spinning
 - Unstable vehicle attitude (spin)
 - External noise interference
 - Vehicle ran with the parking brake applied.
 - Only two wheels are rotated on a drum tester.

DIAGNOSIS

Required Special Tools:

- MB991958 Scan Tool (M.U.T.-III Sub Assembly)
 - MB991824: Vehicle Communication Interface (V.C.I.)
 - MB991827 M.U.T.-III USB Cable
 - MB991910 M.U.T.-III Main Harness A
- MB991997: ASC check harness

STEP 1. Using scan tool MB991958, diagnose the CAN bus lines.

Using scan tool MB991958, diagnose the CAN bus lines.

Q: Is the check result normal?

YES : Go to Step 3.

NO : Repair the CAN bus lines. (Refer to GROUP 54C – Troubleshooting [P.54C-15](#).) After repairing the CAN bus line, go to Step 2.

STEP 2. DTC recheck after repairing the CAN bus line

Q: Is DTC C101F set?

YES : Go to Step 3.

NO : This diagnosis is complete.

STEP 3. Scan tool diagnostic trouble code

Check if DTC No. C1015 is also set.

Q: Is DTC C1015 also set?

YES : Carry out the diagnosis for code No. C1015. (Refer to [P.35C-30](#).)

NO : Go to Step 4.

STEP 4. Check of wheel speed sensor installation status

Check the installation status of wheel speed sensor <FR> (disconnection of wheel speed sensor, looseness of mounting bolt, etc.).

Q: Is the check result normal?

YES : Go to Step 5.

NO : Reinstall the wheel speed sensor <FR> correctly. (Refer to [P.35C-300.](#)) Then go to Step 9.

STEP 5. Check of wheel speed sensor as a single unit

Refer to [P.35C-303.](#)

Q: Is the check result normal?

YES : Go to Step 6.

NO : Replace the wheel speed sensor <FR>. (Refer to [P.35C-300.](#)) Then go to Step 9.

STEP 6. Wheel bearing looseness check

NOTE: Wheel bearing looseness may increase the gap between the wheel speed sensor and the wheel speed detection magnet encoder. Check the wheel bearing <FR> for looseness. (Refer to GROUP 26 –On-vehicle Service [P.26-7.](#))

Q: Is the check result normal?

YES : Go to Step 7.

NO : Replace the front hub assembly. (Refer to GROUP 26 –Front Axle Hub Assembly [P.26-9.](#))

STEP 7. Check of wheel speed detection encoder

Check the encoder for adhesion of foreign materials or deformation.

Q: Is the check result normal?

YES : Go to Step 8.

NO (Adhesion of foreign materials) : Clean the encoder so as not to disturb the magnetization pattern on the encoder while taking care of the magnet, magnetic substance, and magnetic attraction.

NO (Deformation) : Replace the front hub assembly. (Refer to GROUP 26 –Front Axle Hub Assembly [P.26-9.](#))

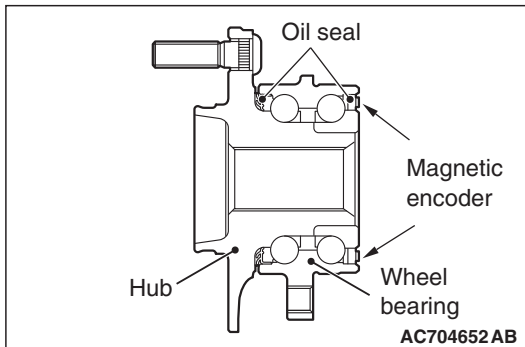
**STEP 8. Check whether the DTC is reset.**

- (1) Erase the diagnostic trouble code.
- (2) Drive the vehicle at 12mph (20 km/h) or more.

NOTE: The ABS warning light does not turn OFF in some cases unless the vehicle runs at 12mph (20 km/h) or higher.

Q: Is DTC C101F set?

YES : Replace the hydraulic unit (incorporates in ASC-ECU).(Refer to [P.35C-298.](#)) Then go to Step 9.

NO : Intermittent malfunction. (Refer to GROUP 00 –How to Cope with Intermittent Malfunction [P.00-15.](#))

STEP 9. Check whether the DTC is reset.

- (1) Erase the diagnostic trouble code.
- (2) Drive the vehicle at 12mph (20 km/h) or more.

NOTE: The ABS warning light does not turn OFF in some cases unless the vehicle runs at 12mph (20 km/h) or higher.

Q: Is DTC C101F set?

YES : Return to Step 1.

NO : This diagnosis is complete.

DTC C102A: Mutual monitoring of RL wheel speed sensor

⚠ CAUTION

- If there is any problem in the CAN bus lines, an incorrect diagnostic trouble code may be set. Prior to this diagnosis, diagnose the CAN bus lines.
- Whenever the ECU is replaced, ensure that the CAN bus lines are normal.
- When the hydraulic unit (integrated with ASC-ECU) is replaced, always perform the calibration of steering wheel sensor, G and yaw rate sensor, brake fluid pressure sensor, cut valve, and inlet valve.(Refer to [P.35C-287](#), [P.35C-289](#), [P.35C-294](#), and [P.35C-295](#).)

CIRCUIT OPERATION

- Each wheel speed detecting section is a kind of a pulse generator. It consists of the encoder (plate on which the north and south pole of magnet are arranged alternately) for detecting the wheel speed, which rotates at the same speed of the wheels, and the wheel speed sensor. This detecting section outputs the frequency pulse signals in proportion to the wheel speed.
- The pulse signals generated by the wheel speed detecting section are sent to ASC-ECU. ASC-ECU uses the frequency of the pulse signals to determine the wheel speed.

DTC SET CONDITIONS

ASC-ECU monitors the signals from each wheel speed sensor while the vehicle is being driven. If any abnormality below is detected in the sensor signals, ASC-ECU sets the relevant diagnostic trouble code.

- Missing wheel speed sensor signal
- Wheel speed sensor signal continuously indicates lower value than the values of other wheel speed sensors.

PROBABLE CAUSES

Current trouble

- Excessive gap between the wheel speed sensor and the magnetic encoder for wheel speed detection
- Adhesion of foreign materials on the wheel speed sensor
- Wheel bearing malfunction
- Deformation of the magnetic encoder for wheel speed detection
- Adhesion of foreign materials on the magnetic encoder for wheel speed detection
- Malfunction of wheel speed sensor
- Improper installation of the wheel speed sensor
- ABS-ECU malfunction
- Disturbance of magnetization pattern for magnetic encoder for wheel speed detection
- The number of poles on the magnetic encoder for wheel speed detection (the number of N-pole and S-pole) is changed.

Past trouble

- When DTC No. C1020 is also set, perform the diagnosis with a particular emphasis on the wiring harness and connector failures between ASC-ECU and the wheel speed sensor. For diagnosis procedures, refer to How to Treat Past Trouble (GROUP 00 –How to Use Troubleshooting/Inspection Service Points [P.00-16](#)).
- When DTC No. C1020 is not set simultaneously, the followings can be suspected.
 - Wheel(s) spinning
 - Unstable vehicle attitude (spin)
 - External noise interference
 - Vehicle ran with the parking brake applied.
 - Only two wheels are rotated on a drum tester.

DIAGNOSIS

Required Special Tools:

- MB991958 Scan Tool (M.U.T.-III Sub Assembly)
 - MB991824: Vehicle Communication Interface (V.C.I.)
 - MB991827 M.U.T.-III USB Cable
 - MB991910 M.U.T.-III Main Harness A
- MB991997: ASC check harness

STEP 1. Using scan tool MB991958, diagnose the CAN bus lines.

Using scan tool MB991958, diagnose the CAN bus lines.

Q: Is the check result normal?

YES : Go to Step 3.

NO : Repair the CAN bus lines. (Refer to GROUP 54C – Troubleshooting [P.54C-15](#).) After repairing the CAN bus line, go to Step 2.

STEP 2. DTC recheck after repairing the CAN bus line

Q: Is DTC C102A set?

YES : Go to Step 3.

NO : This diagnosis is complete.

STEP 3. Scan tool diagnostic trouble code

Check if DTC No. C1020 is also set.

Q: Is DTC C1020 also set?

YES : Carry out the diagnosis for code No. C1020. (Refer to [P.35C-35.](#))

NO : Go to Step 4.

STEP 4. Check of wheel speed sensor installation status

Check the installation status of wheel speed sensor <RL> (disconnection of wheel speed sensor, looseness of mounting bolt, etc.).

Q: Is the check result normal?

YES : Go to Step 5.

NO : Reinstall the wheel speed sensor <RL> correctly. (Refer to [P.35C-300.](#)) Then go to Step 9.

STEP 5. Check of wheel speed sensor as a single unit

Refer to [P.35C-303.](#)

Q: Is the check result normal?

YES : Go to Step 6.

NO : Replace the wheel speed sensor <RL>. (Refer to [P.35C-300.](#)) Then go to Step 9.

STEP 6. Wheel bearing looseness check

NOTE: Wheel bearing looseness may increase the gap between the wheel speed sensor and the wheel speed detection magnet encoder. Check the wheel bearing <RL> for looseness. (Refer to GROUP 27 –On-vehicle Service [P.27-32.](#))

Q: Is the check result normal?

YES : Go to Step 7.

NO : Replace the rear wheel hub assembly. (Refer to GROUP 27 –Rear Axle Hub Assembly [P.27-35.](#))

STEP 7. Check of wheel speed detection encoder

Check the encoder for adhesion of foreign materials or deformation.

Q: Is the check result normal?

YES : Go to Step 8.

NO (Adhesion of foreign materials) : Clean the encoder so as not to disturb the magnetization pattern on the encoder while taking care of the magnet, magnetic substance, and magnetic attraction.

NO (Deformation) : Replace the rear wheel hub assembly. (Refer to GROUP 27 –Rear Axle Hub Assembly [P.27-35.](#))

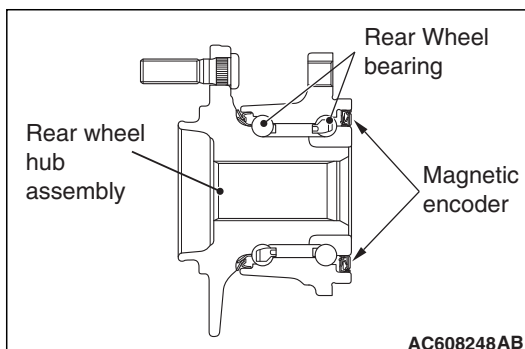

STEP 8. Check whether the DTC is reset.

- (1) Erase the diagnostic trouble code.
- (2) Drive the vehicle at 12mph (20 km/h) or more.

NOTE: The ABS warning light does not turn OFF in some cases unless the vehicle runs at 12mph (20 km/h) or higher.

Q: Is DTC C102A set?

- YES** : Replace the hydraulic unit (incorporates in ASC-ECU).(Refer to [P.35C-298](#).) Then go to Step 9.
- NO** : Intermittent malfunction. (Refer to GROUP 00 –How to Cope with Intermittent Malfunction [P.00-15](#).)

STEP 9. Check whether the DTC is reset.

- (1) Erase the diagnostic trouble code.
- (2) Drive the vehicle at 12mph (20 km/h) or more.

NOTE: The ABS warning light does not turn OFF in some cases unless the vehicle runs at 12mph (20 km/h) or higher.

Q: Is DTC C102A set?

- YES** : Return to Step 1.
- NO** : This diagnosis is complete.

DTC C1035: Mutual monitoring of RR wheel speed sensor

⚠ CAUTION

- If there is any problem in the CAN bus lines, an incorrect diagnostic trouble code may be set. Prior to this diagnosis, diagnose the CAN bus lines.
- Whenever the ECU is replaced, ensure that the CAN bus lines are normal.
- When the hydraulic unit (integrated with ASC-ECU) is replaced, always perform the calibration of steering wheel sensor, G and yaw rate sensor, brake fluid pressure sensor, cut valve, and inlet valve.(Refer to [P.35C-287](#), [P.35C-289](#), [P.35C-294](#), and [P.35C-295](#).)

CIRCUIT OPERATION

- Each wheel speed detecting section is a kind of a pulse generator. It consists of the encoder (plate on which the north and south pole of magnet are arranged alternately) for detecting the wheel speed, which rotates at the same speed of the wheels, and the wheel speed sensor. This detecting section outputs the frequency pulse signals in proportion to the wheel speed.
- The pulse signals generated by the wheel speed detecting section are sent to ASC-ECU. ASC-ECU uses the frequency of the pulse signals to determine the wheel speed.

DTC SET CONDITIONS

ASC-ECU monitors the signals from each wheel speed sensor while the vehicle is being driven. If any abnormality below is detected in the sensor signals, ASC-ECU sets the relevant diagnostic trouble code.

- Missing wheel speed sensor signal
- Wheel speed sensor signal continuously indicates lower value than the values of other wheel speed sensors.

PROBABLE CAUSES

Current trouble

- Excessive gap between the wheel speed sensor and the magnetic encoder for wheel speed detection
- Adhesion of foreign materials on the wheel speed sensor
- Wheel bearing malfunction
- Deformation of the magnetic encoder for wheel speed detection
- Adhesion of foreign materials on the magnetic encoder for wheel speed detection
- Malfunction of wheel speed sensor
- Improper installation of the wheel speed sensor
- ABS-ECU malfunction
- Disturbance of magnetization pattern for magnetic encoder for wheel speed detection
- The number of poles on the magnetic encoder for wheel speed detection (the number of N-pole and S-pole) is changed.

Past trouble

- When DTC No. C102B is also set, perform the diagnosis with a particular emphasis on the wiring harness and connector failures between ASC-ECU and the wheel speed sensor. For diagnosis procedures, refer to How to Treat Past Trouble (GROUP 00 –How to Use Troubleshooting/Inspection Service Points [P.00-16](#)).
- When DTC No. C102B is not set simultaneously, the followings can be suspected.
 - Wheel(s) spinning
 - Unstable vehicle attitude (spin)
 - External noise interference
 - Vehicle ran with the parking brake applied.
 - Only two wheels are rotated on a drum tester.

DIAGNOSIS

Required Special Tools:

- MB991958 Scan Tool (M.U.T.-III Sub Assembly)
 - MB991824: Vehicle Communication Interface (V.C.I.)
 - MB991827 M.U.T.-III USB Cable
 - MB991910 M.U.T.-III Main Harness A
- MB991997: ASC check harness

STEP 1. Using scan tool MB991958, diagnose the CAN bus lines.

Using scan tool MB991958, diagnose the CAN bus lines.

Q: Is the check result normal?

YES : Go to Step 3.

NO : Repair the CAN bus lines. (Refer to GROUP 54C – Troubleshooting [P.54C-15.](#)) After repairing the CAN bus line, go to Step 2.

STEP 2. DTC recheck after repairing the CAN bus line**Q: Is DTC C1035 set?**

YES : Go to Step 3.

NO : This diagnosis is complete.

STEP 3. Scan tool diagnostic trouble code

Check if DTC No. C102B is also set.

Q: Is DTC C102B also set?

YES : Carry out the diagnosis for code No. C102B. (Refer to [P.35C-40.](#))

NO : Go to Step 4.

STEP 4. Check of wheel speed sensor installation status

Check the installation status of wheel speed sensor <RR> (disconnection of wheel speed sensor, looseness of mounting bolt, etc.).

Q: Is the check result normal?

YES : Go to Step 5.

NO : Reinstall the wheel speed sensor <RR> correctly. (Refer to [P.35C-300.](#)) Then go to Step 9.

STEP 5. Check of wheel speed sensor as a single unit

Refer to [P.35C-303.](#)

Q: Is the check result normal?

YES : Go to Step 6.

NO : Replace the wheel speed sensor <RR>. (Refer to [P.35C-300.](#)) Then go to Step 9.

STEP 6. Wheel bearing looseness check

NOTE: Wheel bearing looseness may increase the gap between the wheel speed sensor and the wheel speed detection magnet encoder. Check the wheel bearing <RR> for looseness. (Refer to GROUP 27 –On-vehicle Service [P.27-32.](#))

Q: Is the check result normal?

YES : Go to Step 7.

NO : Replace the rear wheel hub assembly. (Refer to GROUP 27 –Rear Axle Hub Assembly [P.27-35.](#))

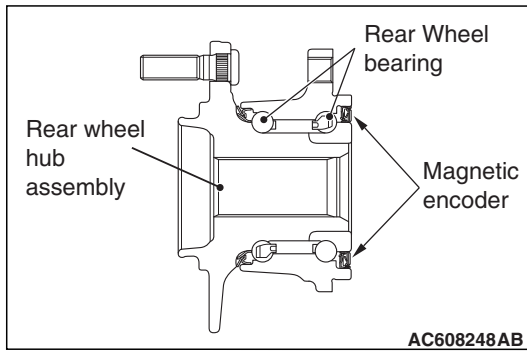

STEP 7. Check of wheel speed detection encoder

Check the encoder for adhesion of foreign materials or deformation.

Q: Is the check result normal?

YES : Go to Step 8.

NO (Adhesion of foreign materials) : Clean the encoder so as not to disturb the magnetization pattern on the encoder while taking care of the magnet, magnetic substance, and magnetic attraction.

NO (Deformation) : Replace the rear wheel hub assembly. (Refer to GROUP 27 –Rear Axle Hub Assembly P.27-35.)

STEP 8. Check whether the DTC is reset.

- (1) Erase the diagnostic trouble code.
- (2) Drive the vehicle at 12mph (20 km/h) or more.

NOTE: The ABS warning light does not turn OFF in some cases unless the vehicle runs at 12mph (20 km/h) or higher.

Q: Is DTC C1035 set?

YES : Replace the hydraulic unit (incorporates in ASC-ECU).(Refer to P.35C-298.) Then go to Step 9.

NO : Intermittent malfunction. (Refer to GROUP 00 –How to Cope with Intermittent Malfunction P.00-15.)

STEP 9. Check whether the DTC is reset.

- (1) Erase the diagnostic trouble code.
- (2) Drive the vehicle at 12mph (20 km/h) or more.

NOTE: The ABS warning light does not turn OFF in some cases unless the vehicle runs at 12mph (20 km/h) or higher.

Q: Is DTC C1035 set?

YES : Return to Step 1.

NO : This diagnosis is complete.

DTC C1041: Abnormality in periodical signal for FL wheel speed sensor

CAUTION

- If there is any problem in the CAN bus lines, an incorrect diagnostic trouble code may be set. Prior to this diagnosis, diagnose the CAN bus lines.
- Whenever the ECU is replaced, ensure that the CAN bus lines are normal.
- When the hydraulic unit (integrated with ASC-ECU) is replaced, always perform the calibration of steering wheel sensor, G and yaw rate sensor, brake fluid pressure sensor, cut valve, and inlet valve.(Refer to P.35C-287, P.35C-289, P.35C-294, and P.35C-295.)

CIRCUIT OPERATION

- Each wheel speed detecting section is a kind of a pulse generator. It consists of the encoder (plate on which the north and south pole of magnet are arranged alternately) for detecting the wheel speed, which rotates at the same speed of the wheels, and the wheel speed sensor. This detecting section outputs the frequency pulse signals in proportion to the wheel speed.
- The pulse signals generated by the wheel speed detecting section are sent to ASC-ECU. ASC-ECU uses the frequency of the pulse signals to determine the wheel speed.

DTC SET CONDITIONS

ASC-ECU monitors the signals from each wheel speed sensor while the vehicle is being driven. If any periodical drop abnormality is detected in the sensor signals, ASC-ECU sets the relevant diagnostic trouble code.

PROBABLE CAUSES

- Wheel bearing malfunction
- Deformation of the magnetic encoder for wheel speed detection
- Adhesion of foreign materials on the magnetic encoder for wheel speed detection
- ABS-ECU malfunction
- Disturbance of magnetization pattern for magnetic encoder for wheel speed detection
- Missing teeth of the magnetic encoder for wheel speed detection

DIAGNOSIS**Required Special Tools:**

- MB991958 Scan Tool (M.U.T.-III Sub Assembly)
 - MB991824: Vehicle Communication Interface (V.C.I.)
 - MB991827 M.U.T.-III USB Cable
 - MB991910 M.U.T.-III Main Harness A
- MB991997: ASC check harness

STEP 1. Using scan tool MB991958, diagnose the CAN bus lines.

Using scan tool MB991958, diagnose the CAN bus lines.

Q: Is the check result normal?

YES : Go to Step 3.

NO : Repair the CAN bus lines. (Refer to GROUP 54C – Troubleshooting [P.54C-15.](#)) After repairing the CAN bus line, go to Step 2.

STEP 2. DTC recheck after repairing the CAN bus line**Q: Is DTC C1041 set?**

YES : Go to Step 3.

NO : This diagnosis is complete.

STEP 3. Wheel bearing looseness check

NOTE: Wheel bearing looseness may increase the gap between the wheel speed sensor and the wheel speed detection magnet encoder. Check the wheel bearing <FL> for looseness. (Refer to GROUP 26 –On-vehicle Service P.26-7.)

Q: Is the check result normal?

YES : Go to Step 4.

NO : Replace the front hub assembly. (Refer to GROUP 26 –Front Axle Hub Assembly P.26-9.)

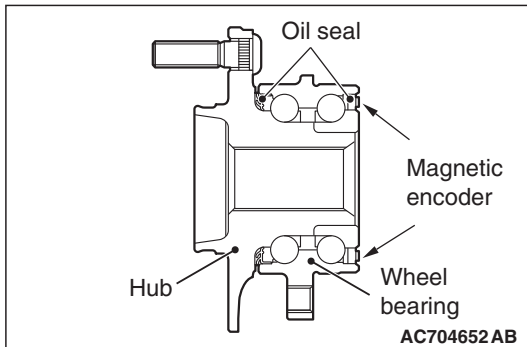

STEP 4. Check of wheel speed detection encoder

Check the encoder for adhesion of foreign materials or deformation.

Q: Is the check result normal?

YES : Go to Step 5.

NO (Adhesion of foreign materials) : Clean the encoder so as not to disturb the magnetization pattern on the encoder while taking care of the magnet, magnetic substance, and magnetic attraction.

NO (Deformation) : Replace the front hub assembly. (Refer to GROUP 26 –Front Axle Hub Assembly P.26-9.)

STEP 5. Check whether the DTC is reset.

- (1) Erase the diagnostic trouble code.
- (2) Drive the vehicle at 12mph (20 km/h) or more.

NOTE: The ABS warning light does not turn OFF in some cases unless the vehicle runs at 12mph (20 km/h) or higher.

Q: Is DTC C1041 set?

YES : Replace the hydraulic unit (incorporates in ASC-ECU).(Refer to P.35C-298.) Then go to Step 6.

NO : Intermittent malfunction. (Refer to GROUP 00 –How to Cope with Intermittent Malfunction P.00-15.)

STEP 6. Check whether the DTC is reset.

- (1) Erase the diagnostic trouble code.
- (2) Drive the vehicle at 12mph (20 km/h) or more.

NOTE: The ABS warning light does not turn OFF in some cases unless the vehicle runs at 12mph (20 km/h) or higher.

Q: Is DTC C1041 set?

YES : Return to Step 1.

NO : This diagnosis is complete.

DTC C1042: Abnormality in periodical signal for FR wheel speed sensor

⚠ CAUTION

- If there is any problem in the CAN bus lines, an incorrect diagnostic trouble code may be set. Prior to this diagnosis, diagnose the CAN bus lines.
- Whenever the ECU is replaced, ensure that the CAN bus lines are normal.
- When the hydraulic unit (integrated with ASC-ECU) is replaced, always perform the calibration of steering wheel sensor, G and yaw rate sensor, brake fluid pressure sensor, cut valve, and inlet valve.(Refer to [P.35C-287](#), [P.35C-289](#), [P.35C-294](#), and [P.35C-295](#).)

CIRCUIT OPERATION

- Each wheel speed detecting section is a kind of a pulse generator. It consists of the encoder (plate on which the north and south pole of magnet are arranged alternately) for detecting the wheel speed, which rotates at the same speed of the wheels, and the wheel speed sensor. This detecting section outputs the frequency pulse signals in proportion to the wheel speed.
- The pulse signals generated by the wheel speed detecting section are sent to ASC-ECU. ASC-ECU uses the frequency of the pulse signals to determine the wheel speed.

DTC SET CONDITIONS

ASC-ECU monitors the signals from each wheel speed sensor while the vehicle is being driven. If any periodical drop abnormality is detected in the sensor signals, ASC-ECU sets the relevant diagnostic trouble code.

PROBABLE CAUSES

- Wheel bearing malfunction
- Deformation of the magnetic encoder for wheel speed detection
- Adhesion of foreign materials on the magnetic encoder for wheel speed detection
- ASC-ECU malfunction
- Disturbance of magnetization pattern for magnetic encoder for wheel speed detection
- Missing teeth of the magnetic encoder for wheel speed detection

DIAGNOSIS**Required Special Tools:**

- MB991958 Scan Tool (M.U.T.-III Sub Assembly)
 - MB991824: Vehicle Communication Interface (V.C.I.)
 - MB991827 M.U.T.-III USB Cable
 - MB991910 M.U.T.-III Main Harness A
- MB991997: ASC check harness

STEP 1. Using scan tool MB991958, diagnose the CAN bus lines.

Using scan tool MB991958, diagnose the CAN bus lines.

Q: Is the check result normal?

YES : Go to Step 3.

NO : Repair the CAN bus lines. (Refer to GROUP 54C – Troubleshooting [P.54C-15.](#)) After repairing the CAN bus line, go to Step 2.

STEP 2. DTC recheck after repairing the CAN bus line

Q: Is DTC C1042 set?

YES : Go to Step 3.

NO : This diagnosis is complete.

STEP 3. Wheel bearing looseness check

NOTE: Wheel bearing looseness may increase the gap between the wheel speed sensor and the wheel speed detection magnet encoder. Check the wheel bearing <FR> for looseness. (Refer to GROUP 26 –On-vehicle Service [P.26-7.](#))

Q: Is the check result normal?

YES : Go to Step 4.

NO : Replace the front hub assembly. (Refer to GROUP 26 –Front Axle Hub Assembly [P.26-9.](#))

STEP 4. Check of wheel speed detection encoder

Check the encoder for adhesion of foreign materials or deformation.

Q: Is the check result normal?

YES : Go to Step 5.

NO (Adhesion of foreign materials) : Clean the encoder so as not to disturb the magnetization pattern on the encoder while taking care of the magnet, magnetic substance, and magnetic attraction.

NO (Deformation) : Replace the front hub assembly. (Refer to GROUP 26 –Front Axle Hub Assembly [P.26-9.](#))

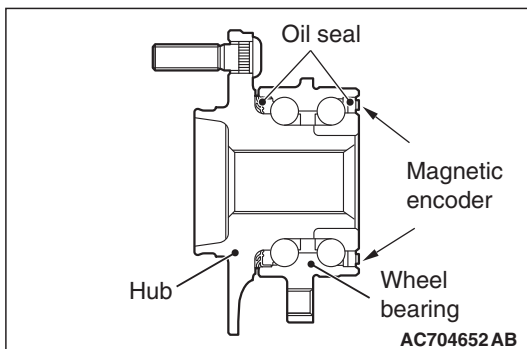

STEP 5. Check whether the DTC is reset.

- (1) Erase the diagnostic trouble code.
- (2) Drive the vehicle at 12mph (20 km/h) or more.

NOTE: The ABS warning light does not turn OFF in some cases unless the vehicle runs at 12mph (20 km/h) or higher.

Q: Is DTC C1042 set?

YES : Replace the hydraulic unit (incorporates in ASC-ECU).(Refer to [P.35C-298.](#)) Then go to Step 6.

NO : Intermittent malfunction. (Refer to GROUP 00 –How to Cope with Intermittent Malfunction [P.00-15.](#))

STEP 6. Check whether the DTC is reset.

- (1) Erase the diagnostic trouble code.
- (2) Drive the vehicle at 12mph (20 km/h) or more.

NOTE: The ABS warning light does not turn OFF in some cases unless the vehicle runs at 12mph (20 km/h) or higher.

Q: Is DTC C1042 set?

YES : Return to Step 1.

NO : This diagnosis is complete.

DTC C1043: Abnormality in periodical signal for RL wheel speed sensor

⚠ CAUTION

- If there is any problem in the CAN bus lines, an incorrect diagnostic trouble code may be set. Prior to this diagnosis, diagnose the CAN bus lines.
- Whenever the ECU is replaced, ensure that the CAN bus lines are normal.
- When the hydraulic unit (integrated with ASC-ECU) is replaced, always perform the calibration of steering wheel sensor, G and yaw rate sensor, brake fluid pressure sensor, cut valve, and inlet valve. (Refer to [P.35C-287](#), [P.35C-289](#), [P.35C-294](#), and [P.35C-295](#).)

CIRCUIT OPERATION

- Each wheel speed detecting section is a kind of a pulse generator. It consists of the encoder (plate on which the north and south pole of magnet are arranged alternately) for detecting the wheel speed, which rotates at the same speed of the wheels, and the wheel speed sensor. This detecting section outputs the frequency pulse signals in proportion to the wheel speed.
- The pulse signals generated by the wheel speed detecting section are sent to ASC-ECU. ASC-ECU uses the frequency of the pulse signals to determine the wheel speed.

DTC SET CONDITIONS

ASC-ECU monitors the signals from each wheel speed sensor while the vehicle is being driven. If any periodical drop abnormality is detected in the sensor signals, ASC-ECU sets the relevant diagnostic trouble code.

PROBABLE CAUSES

- Wheel bearing malfunction
- Deformation of the magnetic encoder for wheel speed detection
- Adhesion of foreign materials on the magnetic encoder for wheel speed detection
- ABS-ECU malfunction

- Disturbance of magnetization pattern for magnetic encoder for wheel speed detection
- Missing teeth of the magnetic encoder for wheel speed detection

DIAGNOSIS

Required Special Tools:

- MB991958 Scan Tool (M.U.T.-III Sub Assembly)
 - MB991824: Vehicle Communication Interface (V.C.I.)
 - MB991827 M.U.T.-III USB Cable
 - MB991910 M.U.T.-III Main Harness A
- MB991997: ASC check harness

STEP 1. Using scan tool MB991958, diagnose the CAN bus lines.

Using scan tool MB991958, diagnose the CAN bus lines.

Q: Is the check result normal?

YES : Go to Step 3.

NO : Repair the CAN bus lines. (Refer to GROUP 54C – Troubleshooting P.54C-15.) After repairing the CAN bus line, go to Step 2.

STEP 2. DTC recheck after repairing the CAN bus line

Q: Is DTC C1043 set?

YES : Go to Step 3.

NO : This diagnosis is complete.

STEP 3. Wheel bearing looseness check

NOTE: Wheel bearing looseness may increase the gap between the wheel speed sensor and the wheel speed detection magnet encoder. Check the wheel bearing <RL> for looseness. (Refer to GROUP 27 –On-vehicle Service P.27-32.)

Q: Is the check result normal?

YES : Go to Step 4.

NO : Replace the rear wheel hub assembly. (Refer to GROUP 27 –Rear Axle Hub Assembly P.27-35.)

STEP 4. Check of wheel speed detection encoder

Check the encoder for adhesion of foreign materials or deformation.

Q: Is the check result normal?

YES : Go to Step 5.

NO (Adhesion of foreign materials) : Clean the encoder so as not to disturb the magnetization pattern on the encoder while taking care of the magnet, magnetic substance, and magnetic attraction.

NO (Deformation) : Replace the rear wheel hub assembly. (Refer to GROUP 27 –Rear Axle Hub Assembly P.27-35.)

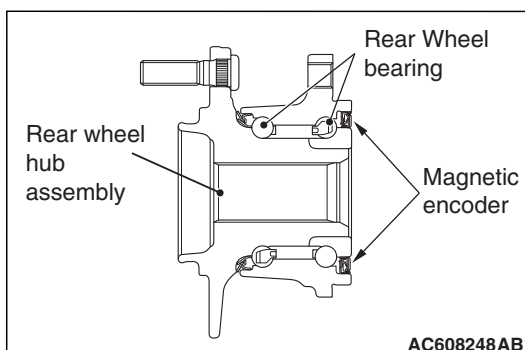

STEP 5. Check whether the DTC is reset.

- (1) Erase the diagnostic trouble code.
- (2) Drive the vehicle at 12mph (20 km/h) or more.

NOTE: The ABS warning light does not turn OFF in some cases unless the vehicle runs at 12mph (20 km/h) or higher.

Q: Is DTC C1043 set?

- YES** : Replace the hydraulic unit (incorporates in ASC-ECU).(Refer to [P.35C-298.](#)) Then go to Step 6.
- NO** : Intermittent malfunction. (Refer to GROUP 00 –How to Cope with Intermittent Malfunction [P.00-15.](#))

STEP 6. Check whether the DTC is reset.

- (1) Erase the diagnostic trouble code.
- (2) Drive the vehicle at 12mph (20 km/h) or more.

NOTE: The ABS warning light does not turn OFF in some cases unless the vehicle runs at 12mph (20 km/h) or higher.

Q: Is DTC C1043 set?

- YES** : Return to Step 1.
- NO** : This diagnosis is complete.

DTC C1044: Abnormality in periodical signal for RR wheel speed sensor

⚠ CAUTION

- If there is any problem in the CAN bus lines, an incorrect diagnostic trouble code may be set. Prior to this diagnosis, diagnose the CAN bus lines.
- Whenever the ECU is replaced, ensure that the CAN bus lines are normal.
- When the hydraulic unit (integrated with ASC-ECU) is replaced, always perform the calibration of steering wheel sensor, G and yaw rate sensor, brake fluid pressure sensor, cut valve, and inlet valve.(Refer to [P.35C-287](#), [P.35C-289](#), [P.35C-294](#), and [P.35C-295.](#))

DTC SET CONDITIONS

- Each wheel speed detecting section is a kind of a pulse generator. It consists of the encoder (plate on which the north and south pole of magnet are arranged alternately) for detecting the wheel speed, which rotates at the same speed of the wheels, and the wheel speed sensor. This detecting section outputs the frequency pulse signals in proportion to the wheel speed.
- The pulse signals generated by the wheel speed detecting section are sent to ASC-ECU. ASC-ECU uses the frequency of the pulse signals to determine the wheel speed.

DTC SET CONDITIONS

ASC-ECU monitors the signals from each wheel speed sensor while the vehicle is being driven. If any periodical drop abnormality is detected in the sensor signals, ASC-ECU sets the relevant diagnostic trouble code.

PROBABLE CAUSES

- Wheel bearing malfunction
- Deformation of the magnetic encoder for wheel speed detection
- Adhesion of foreign materials on the magnetic encoder for wheel speed detection
- ABS-ECU malfunction
- Disturbance of magnetization pattern for magnetic encoder for wheel speed detection
- Missing teeth of the magnetic encoder for wheel speed detection

DIAGNOSIS

Required Special Tools:

- MB991958 Scan Tool (M.U.T.-III Sub Assembly)
 - MB991824: Vehicle Communication Interface (V.C.I.)
 - MB991827 M.U.T.-III USB Cable
 - MB991910 M.U.T.-III Main Harness A
- MB991997: ASC check harness

STEP 1. Using scan tool MB991958, diagnose the CAN bus lines.

Using scan tool MB991958, diagnose the CAN bus lines.

Q: Is the check result normal?

YES : Go to Step 3.

NO : Repair the CAN bus lines. (Refer to GROUP 54C – Troubleshooting [P.54C-15.](#)) After repairing the CAN bus line, go to Step 2.

STEP 2. DTC recheck after repairing the CAN bus line

Q: Is DTC C1044 set?

YES : Go to Step 3.

NO : This diagnosis is complete.

STEP 3. Wheel bearing looseness check

NOTE: Wheel bearing looseness may increase the gap between the wheel speed sensor and the wheel speed detection magnet encoder. Check the wheel bearing <RR> for looseness. (Refer to GROUP 27 –On-vehicle Service [P.27-32.](#))

Q: Is the check result normal?

YES : Go to Step 4.

NO : Replace the rear wheel hub assembly. (Refer to GROUP 27 –Rear Axle Hub Assembly [P.27-35.](#))

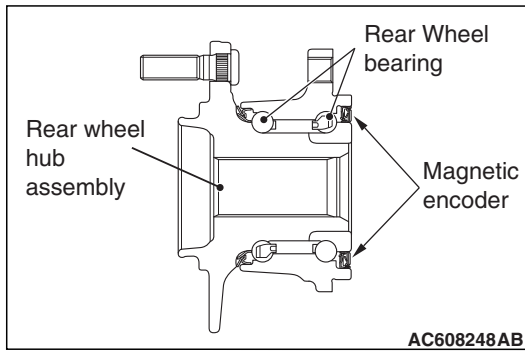
**STEP 4. Check of wheel speed detection encoder**

Check the encoder for adhesion of foreign materials or deformation.

Q: Is the check result normal?

YES : Go to Step 5.

NO (Adhesion of foreign materials) : Clean the encoder so as not to disturb the magnetization pattern on the encoder while taking care of the magnet, magnetic substance, and magnetic attraction.

NO (Deformation) : Replace the rear wheel hub assembly. (Refer to GROUP 27 –Rear Axle Hub Assembly P.27-35.)

STEP 5. Check whether the DTC is reset.

- (1) Erase the diagnostic trouble code.
- (2) Drive the vehicle at 12mph (20 km/h) or more.

NOTE: The ABS warning light does not turn OFF in some cases unless the vehicle runs at 12mph (20 km/h) or higher.

Q: Is DTC C1044 set?

YES : Replace the hydraulic unit (incorporates in ASC-ECU).(Refer to P.35C-298.) Then go to Step 6.

NO : Intermittent malfunction. (Refer to GROUP 00 –How to Cope with Intermittent Malfunction P.00-15.)

STEP 6. Check whether the DTC is reset.

- (1) Erase the diagnostic trouble code.
- (2) Drive the vehicle at 12mph (20 km/h) or more.

NOTE: The ABS warning light does not turn OFF in some cases unless the vehicle runs at 12mph (20 km/h) or higher.

Q: Is DTC C1044 set?

YES : Return to Step 1.

NO : This diagnosis is complete.

DTC C1046: FL wheel speed sensor control phase time exceeded

Wheel Speed Sensor Circuit

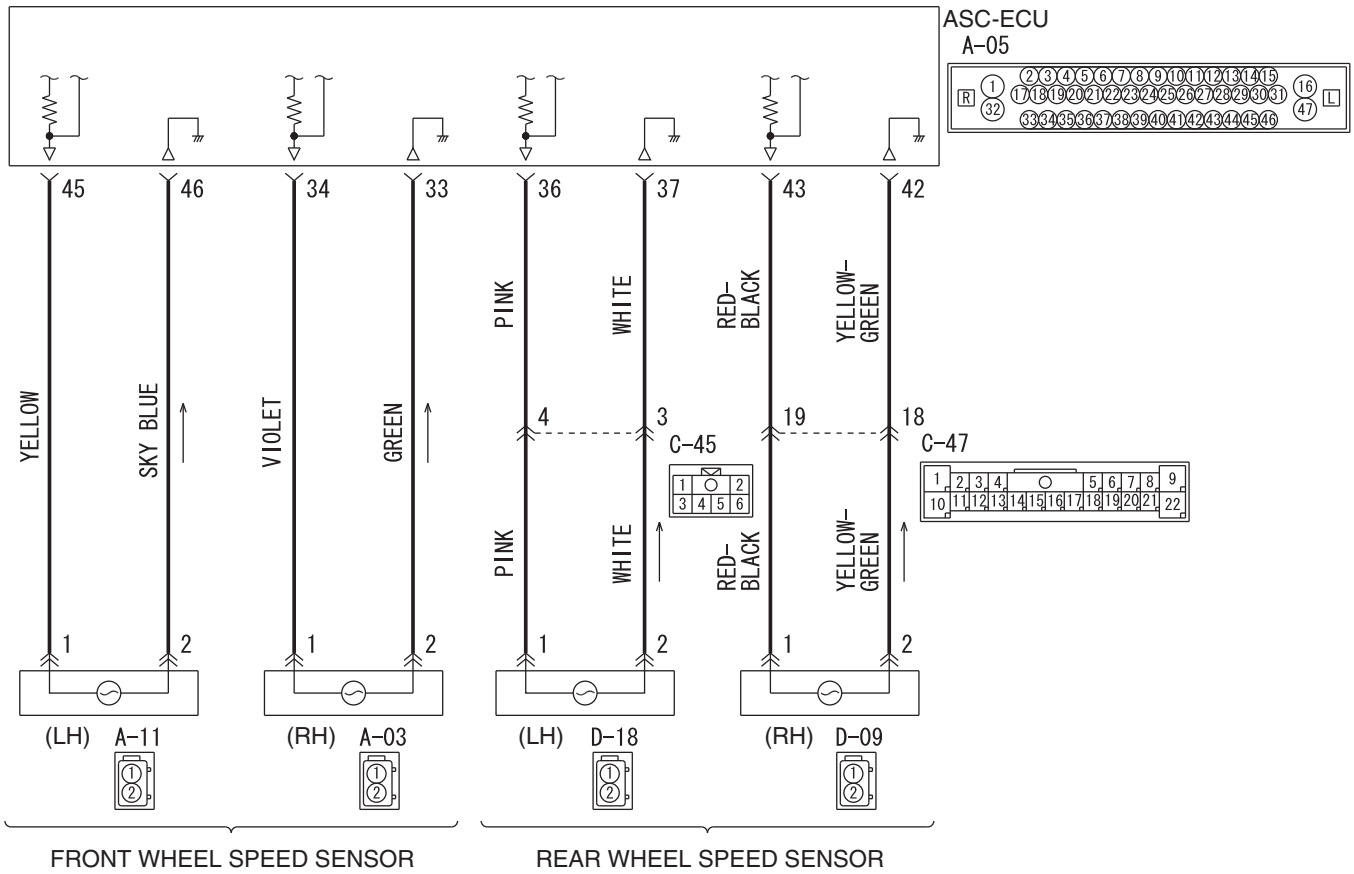

AC804587

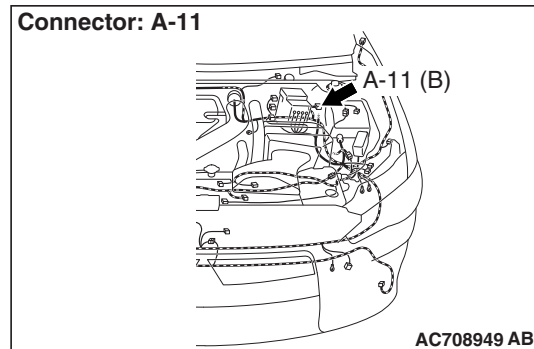
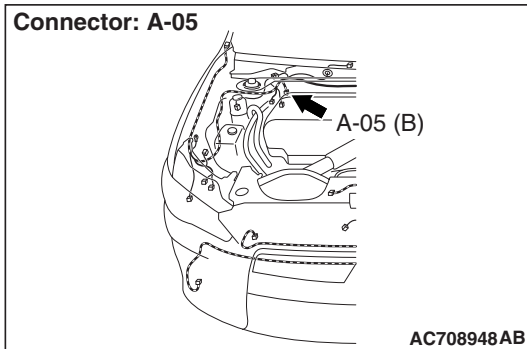

⚠ CAUTION

- If there is any problem in the CAN bus lines, an incorrect diagnostic trouble code may be set. Prior to this diagnosis, diagnose the CAN bus lines.
- Whenever the ECU is replaced, ensure that the CAN bus lines are normal.
- When the hydraulic unit (integrated with ASC-ECU) is replaced, always perform the calibration of steering wheel sensor, G and yaw rate sensor, brake fluid pressure sensor, cut valve, and inlet valve. (Refer to [P.35C-287](#), [P.35C-289](#), [P.35C-294](#), and [P.35C-295](#).)

CIRCUIT OPERATION

- Each wheel speed detecting section is a kind of a pulse generator. It consists of the encoder (plate on which the north and south pole of magnet are arranged alternately) for detecting the wheel speed, which rotates at the same speed of the wheels, and the wheel speed sensor. This detecting section outputs the frequency pulse signals in proportion to the wheel speed.
- The pulse signals generated by the wheel speed detecting section are sent to ASC-ECU. ASC-ECU uses the frequency of the pulse signals to determine the wheel speed.

DTC SET CONDITIONS

This diagnostic trouble code is set if any malfunction below is detected.

- When the brake fluid pressure is decreased for a long time.
- When the brake fluid pressure is held for a long time.

NOTE: ASC controls the vehicle based on the wheel speed signal. When the brake fluid pressure is decreased or held for an abnormally long time, the wheel speed sensor signal may have a problem.

PROBABLE CAUSES

- Damaged wiring harness and connectors
- External noise interference
- Malfunction of wheel speed sensor
- ABS-ECU malfunction
- Excessive gap between the wheel speed sensor and the magnetic encoder for wheel speed detection
- Adhesion of foreign materials on the wheel speed sensor
- Adhesion of foreign materials on the magnetic encoder for wheel speed detection
- Wheel bearing malfunction
- Improper installation of the wheel speed sensor
- Deformation of the magnetic encoder for wheel speed detection
- Disturbance of magnetization pattern for magnetic encoder for wheel speed detection
- Missing teeth of the magnetic encoder for wheel speed detection

DIAGNOSIS

Required Special Tools:

- MB991958 Scan Tool (M.U.T.-III Sub Assembly)
 - MB991824: Vehicle Communication Interface (V.C.I.)
 - MB991827 M.U.T.-III USB Cable
 - MB991910 M.U.T.-III Main Harness A
- MB991997: ASC check harness

STEP 1. Using scan tool MB991958, diagnose the CAN bus lines.

Using scan tool MB991958, diagnose the CAN bus lines.

Q: Is the check result normal?

YES : Go to Step 3.

NO : Repair the CAN bus lines. (Refer to GROUP 54C – Troubleshooting [P.54C-15](#).) After repairing the CAN bus line, go to Step 2.

STEP 2. DTC recheck after repairing the CAN bus line

Q: Is DTC C1046 set?

YES : Go to Step 3.

NO : This diagnosis is complete.

STEP 3. Scan tool diagnostic trouble code

Check whether DTC No. C100A, C1011, C1014, and C1041 are simultaneously set.

Q: Are DTC C100A, C1011, C1014, and C1041 also set?

YES : Carry out the diagnosis for the diagnostic trouble codes that are set, and then go to Step 5.

NO : Go to Step 4.

STEP 4. Scan tool service data

Check the following service data. (Refer to [P.35C-276](#).)

- Item No.01: FL wheel speed sensor

Q: Is the check result normal?

YES : Go to Step 16.

NO : Go to Step 5.

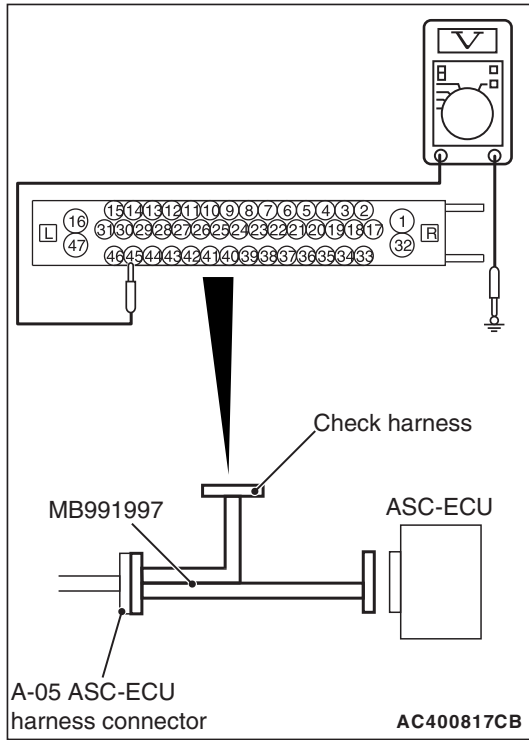

STEP 5. Voltage measurement at A-05 ASC-ECU connector

- (1) Disconnect the ASC-ECU connector, connect the special tool ASC check harness (MB991997) to the wiring harness-side connector, and then measure at the special tool connector side.

NOTE: Do not connect the special tool to ASC-ECU.

- (2) Turn the ignition switch to the ON position.
- (3) Measure the voltage between the wheel speed sensor power supply terminal (signal terminal) No. 45 and the body ground as well as between the ground terminal No. 46 and the body ground.

OK: 1 volt or less

Q: Is the check result normal?

YES : Go to Step 6.

NO (Not normal at the terminal No. 45 or 46) : Go to Step 7.

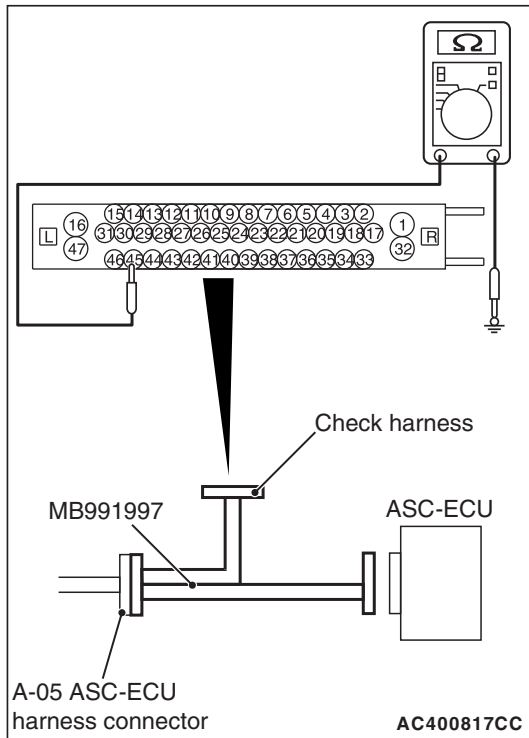

STEP 6. Resistance measurement at A-05 ASC-ECU connector

- (1) Disconnect the ASC-ECU connector, connect the special tool ASC check harness (MB991997) to the wiring harness-side connector, and then measure at the special tool connector side.

NOTE: Do not connect the special tool to ASC-ECU.

- (2) Measure the resistance between the wheel speed sensor circuit power supply terminal (signal terminal) No. 45 and the body ground as well as between the ground terminal No. 46 and the body ground.

OK: No continuity

Q: Is the check result normal?

YES : Go to Step 9.

NO (Not normal at the terminal No. 45 or 46) : Go to Step 7.

STEP 7. Connector check: A-05 ASC-ECU connector, A-11 wheel speed sensor <FL> connector

Q: Is the check result normal?

YES : Go to Step 8.

NO : Repair the defective connector. Then go to Step 17.

STEP 8. Wiring harness check between A-05 ASC-ECU connector terminal No. 45 and A-11 wheel speed sensor <FL> connector terminal No. 1, and between A-05 ASC-ECU connector terminal No. 46 and A-11 wheel speed sensor <FL> connector terminal No. 2

- Short circuit check of wheel speed sensor <FL> circuit

Q: Is the check result normal?

YES : Replace the wheel speed sensor <FL>. (Refer to [P.35C-300.](#)) Then go to Step 17.

NO : Repair the wiring harness. Then go to Step 17.

STEP 9. Voltage measurement at A-05 ASC-ECU connector

- (1) Disconnect the ASC-ECU connector, connect the special tool ASC check harness (MB991997) to the ASC-ECU-side connector and the wiring harness-side connector, and then measure at the special tool connector side.
- (2) Turn the ignition switch to the ON position.
- (3) Measure the voltage between the wheel speed sensor circuit power supply terminal (signal terminal) No. 45 and the body ground.

OK: Battery positive voltage

Q: Is the check result normal?

YES : Go to Step 10.

NO : Go to Step 12.

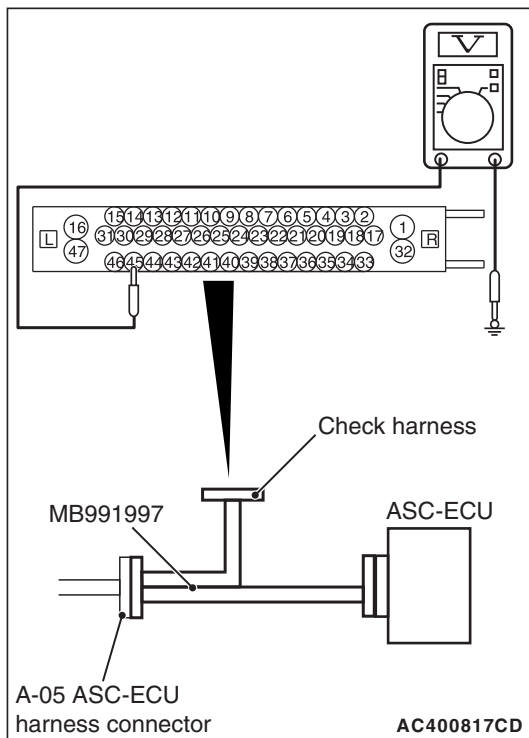

STEP 10. Wiring harness check between A-05 ASC-ECU connector terminal No. 45 and A-11 wheel speed sensor <FL> connector terminal No. 1, and between A-05 ASC-ECU connector terminal No. 46 and A-11 wheel speed sensor <FL> connector terminal No. 2

- Open circuit check of wheel speed sensor <FL> circuit

Q: Is the check result normal?

YES : Go to Step 11.

NO : Repair the wiring harness. Then go to Step 17.

STEP 11. Check of wheel speed sensor as a single unit

Refer to [P.35C-303](#).

Q: Is the check result normal?

YES : Go to Step 13.

NO : Replace the wheel speed sensor <FL>. (Refer to [P.35C-300](#).) Then go to Step 17.

STEP 12. Connector check: A-05 ASC-ECU connector, A-11 wheel speed sensor <FL> connector**Q: Is the check result normal?**

YES : Go to Step 16.

NO : Repair the defective connector. Then go to Step 17.

STEP 13. Check of wheel speed sensor installation status

Check the installation status of wheel speed sensor <FL> (disconnection of wheel speed sensor, looseness of mounting bolt, etc.).

Q: Is the check result normal?

YES : Go to Step 14.

NO : Reinstall the wheel speed sensor <FL> correctly. (Refer to [P.35C-300](#).) Then go to Step 17.

STEP 14. Wheel bearing looseness check**NOTE:**

- Wheel bearing looseness may increase the gap between the wheel speed sensor and the wheel speed detection magnet encoder.
- Check the wheel bearing <FL> for looseness. (Refer to **GROUP 26 –On-vehicle Service** [P.26-7](#).)

Q: Is the check result normal?

YES : Go to Step 15.

NO : Replace the front hub assembly. (Refer to **GROUP 26 –Front Axle Hub Assembly** [P.26-9](#).)

STEP 15. Check of wheel speed detection encoder

Check the encoder for adhesion of foreign materials or deformation.

Q: Is the check result normal?

YES : Go to Step 16.

NO (Adhesion of foreign materials) : Clean the encoder so as not to disturb the magnetization pattern on the encoder while taking care of the magnet, magnetic substance, and magnetic attraction.

NO (Deformation) : Replace the front hub assembly. (Refer to **GROUP 26 –Front Axle Hub Assembly** [P.26-9](#).)

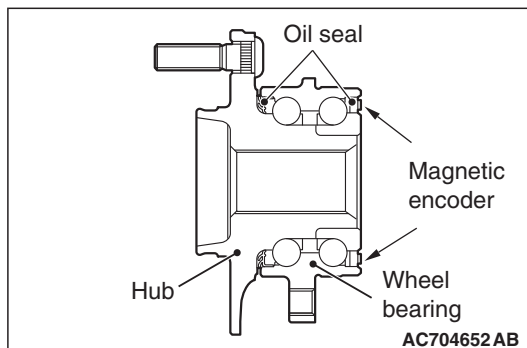

STEP 16. Check whether the DTC is reset.

Drive the vehicle at 12mph (20 km/h) or more.

NOTE: The ABS warning light does not turn OFF in some cases unless the vehicle runs at 12mph (20 km/h) or higher.

Q: Is DTC C1046 set?

YES : Replace the hydraulic unit (incorporates in ASC-ECU).(Refer to P.35C-298.) Then go to Step 17.

NO : Intermittent malfunction. (Refer to GROUP 00 –How to Cope with Intermittent Malfunction P.00-15.)

STEP 17. Check whether the DTC is reset.

Drive the vehicle at 12mph (20 km/h) or more.

NOTE: The ABS warning light does not turn OFF in some cases unless the vehicle runs at 12mph (20 km/h) or higher.

Q: Is DTC C1046 set?

YES : Return to Step 1.

NO : This diagnosis is complete.

DTC C1047: FR wheel speed sensor control phase time exceeded

Wheel Speed Sensor Circuit

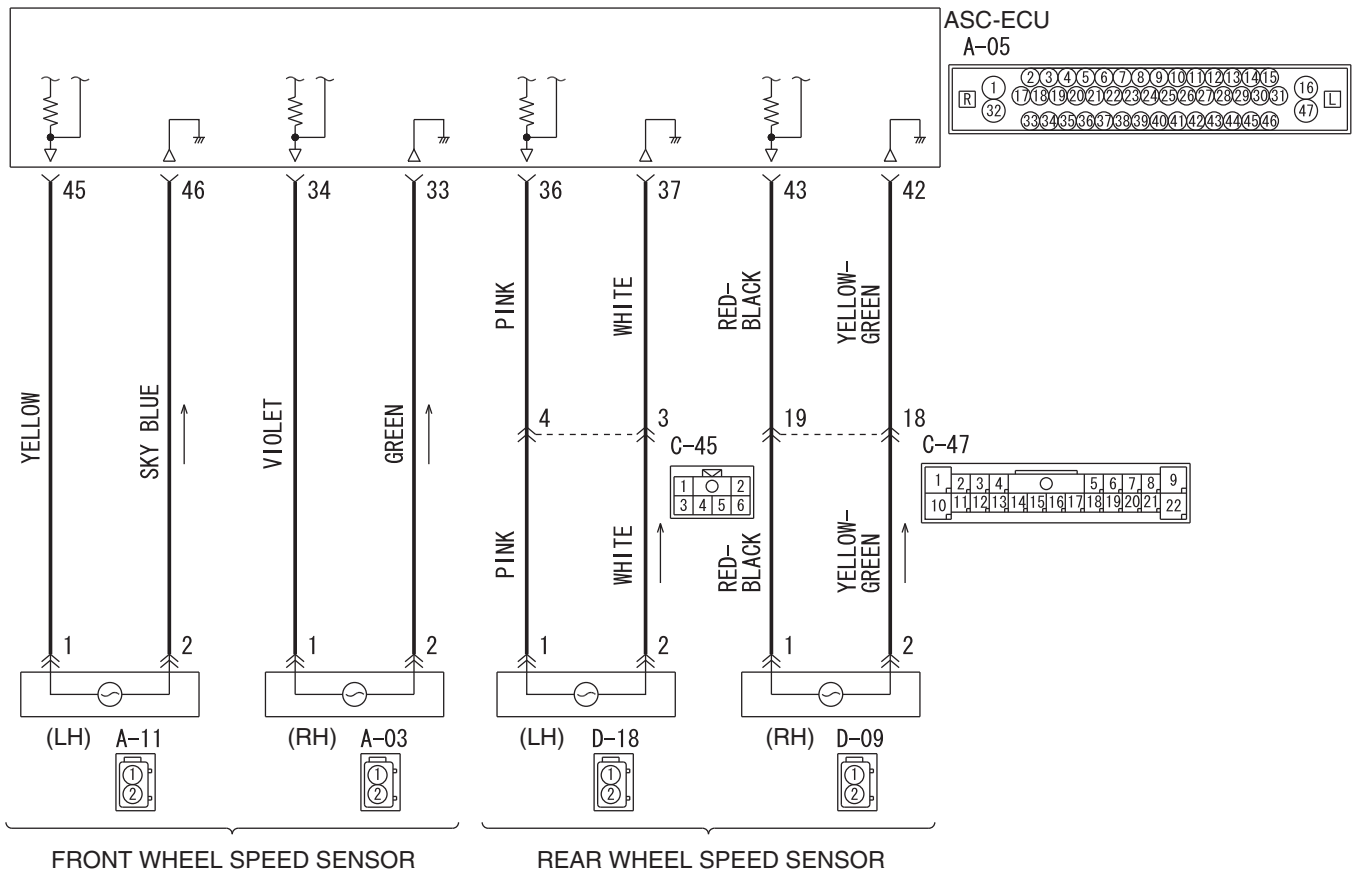

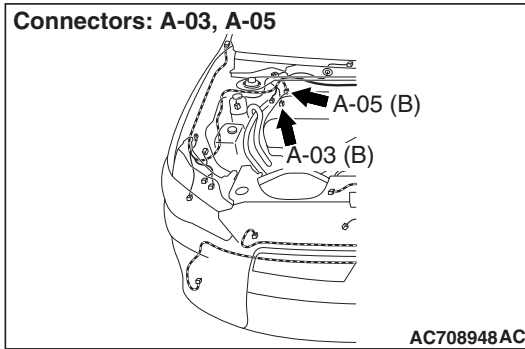

⚠ CAUTION

- If there is any problem in the CAN bus lines, an incorrect diagnostic trouble code may be set. Prior to this diagnosis, diagnose the CAN bus lines.
- Whenever the ECU is replaced, ensure that the CAN bus lines are normal.
- When the hydraulic unit (integrated with ASC-ECU) is replaced, always perform the calibration of steering wheel sensor, G and yaw rate sensor, brake fluid pressure sensor, cut valve, and inlet valve. (Refer to [P.35C-287](#), [P.35C-289](#), [P.35C-294](#), and [P.35C-295](#).)

CIRCUIT OPERATION

- Each wheel speed detecting section is a kind of a pulse generator. It consists of the encoder (plate on which the north and south pole of magnet are arranged alternately) for detecting the wheel speed, which rotates at the same speed of the wheels, and the wheel speed sensor. This detecting section outputs the frequency pulse signals in proportion to the wheel speed.
- The pulse signals generated by the wheel speed detecting section are sent to ASC-ECU. ASC-ECU uses the frequency of the pulse signals to determine the wheel speed.

DTC SET CONDITIONS

This diagnostic trouble code is set if any malfunction below is detected.

- When the brake fluid pressure is decreased for a long time.
- When the brake fluid pressure is held for a long time.

NOTE: ABS controls the vehicle based on the wheel speed signal. When the brake fluid pressure is decreased or held for an abnormally long time, the wheel speed sensor signal may have a problem.

PROBABLE CAUSES

- Damaged wiring harness and connectors
- External noise interference
- Malfunction of wheel speed sensor
- ABS-ECU malfunction

- Excessive gap between the wheel speed sensor and the wheel speed detection encoder
- Adhesion of foreign materials on the wheel speed sensor
- Adhesion of foreign materials on the wheel speed detection encoder
- Wheel bearing malfunction
- Improper installation of the wheel speed sensor
- Deformation of the wheel speed detection encoder
- Disturbance of magnetization pattern for wheel speed detection encoder
- Missing teeth of the wheel speed detection encoder

DIAGNOSIS

Required Special Tools:

- MB991958 Scan Tool (M.U.T.-III Sub Assembly)
 - MB991824: Vehicle Communication Interface (V.C.I.)
 - MB991827 M.U.T.-III USB Cable
 - MB991910 M.U.T.-III Main Harness A
- MB991997: ASC check harness

STEP 1. Using scan tool MB991958, diagnose the CAN bus lines.

Using scan tool MB991958, diagnose the CAN bus lines.

Q: Is the check result normal?

YES : Go to Step 3.

NO : Repair the CAN bus lines. (Refer to GROUP 54C – Troubleshooting [P.54C-15](#).) After repairing the CAN bus line, go to Step 2.

STEP 2. DTC recheck after repairing the CAN bus line

Q: Is DTC C1047 set?

YES : Go to Step 3.

NO : This diagnosis is complete.

STEP 3. Scan tool diagnostic trouble code

Check that the diagnostic trouble codes No. C1015, C101C, C101F, and C1042 are simultaneously set.

Q: Are DTC C1015, C101C, C101F, and C1042 also set?

YES : Carry out the diagnosis for the diagnostic trouble codes that are set, and then go to Step 5.

NO : Go to Step 4.

STEP 4. Scan tool service data

Check the following service data. (Refer to [P.35C-276](#).)

- Item No.02: FR wheel speed sensor

Q: Is the check result normal?

YES : Go to Step 16.

NO : Go to Step 5.

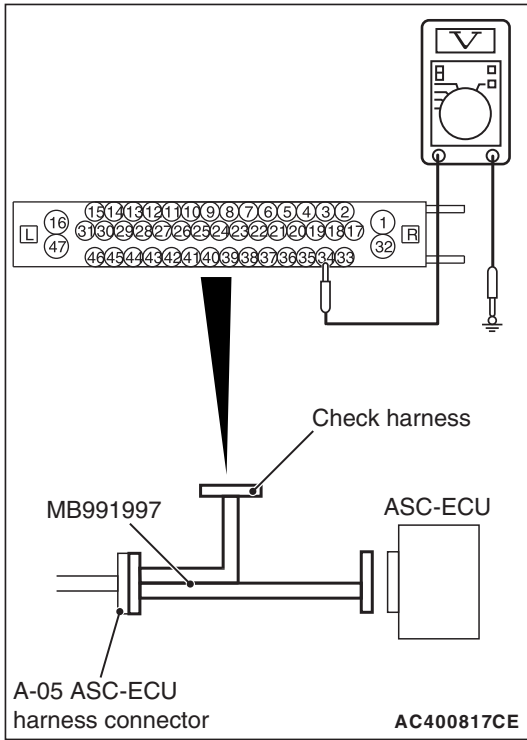

STEP 5. Voltage measurement at A-05 ASC-ECU connector

- (1) Disconnect the ASC-ECU connector, connect the special tool ASC check harness (MB991997) to the wiring harness-side connector, and then measure at the special tool connector side.

NOTE: Do not connect the special tool to ASC-ECU.

- (2) Turn the ignition switch to the ON position.
- (3) Measure the voltage between the wheel speed sensor power supply terminal (signal terminal) No. 34 and the body ground as well as between the ground terminal No. 33 and the body ground.

OK: 1 volt or less

Q: Is the check result normal?

YES : Go to Step 6.

NO (Not normal at terminal 34 or 33) : Go to Step 7.

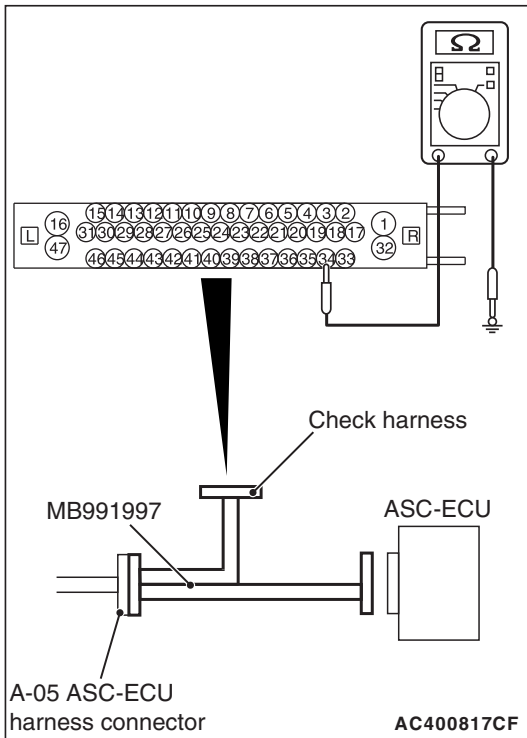

STEP 6. Resistance measurement at A-05 ASC-ECU connector

- (1) Disconnect the ASC-ECU connector, connect the special tool ASC check harness (MB991997) to the wiring harness-side connector, and then measure at the special tool connector side.

NOTE: Do not connect the special tool to ASC-ECU.

- (2) Measure the resistance between the wheel speed sensor circuit power supply terminal (signal terminal) No. 34 and the body ground as well as between the ground terminal No. 33 and the body ground.

OK: No continuity

Q: Is the check result normal?

YES : Go to Step 9.

NO (Not normal at terminal No. 34 or 33) : Go to Step 7.

STEP 7. Connector check: A-05 ASC-ECU connector, A-03 wheel speed sensor <FR> connector

Q: Is the check result normal?

YES : Go to Step 8.

NO : Repair the defective connector. Then go to Step 17.

STEP 8. Wiring harness check between A-05 ASC-ECU connector terminal No. 34 and A-03 wheel speed sensor <FR> connector terminal No. 1, and between A-05 ASC-ECU connector terminal No. 33 and A-03 wheel speed sensor <FR> connector terminal No. 2

- Short circuit check of wheel speed sensor <FR> circuit

Q: Is the check result normal?

YES : Replace the wheel speed sensor <FR>. (Refer to [P.35C-300.](#)) Then go to Step 17.

NO : Repair the wiring harness. Then go to Step 17.

STEP 9. Voltage measurement at A-05 ASC-ECU connector

- (1) Disconnect the ASC-ECU connector, connect the special tool ASC check harness (MB991997) to the ASC-ECU-side connector and the wiring harness-side connector, and then measure at the special tool connector side.
- (2) Turn the ignition switch to the ON position.
- (3) Measure the voltage between the wheel speed sensor circuit power supply terminal (signal terminal) No. 34 and the body ground.

OK: Battery positive voltage

Q: Is the check result normal?

YES : Go to Step 10.

NO : Go to Step 12.

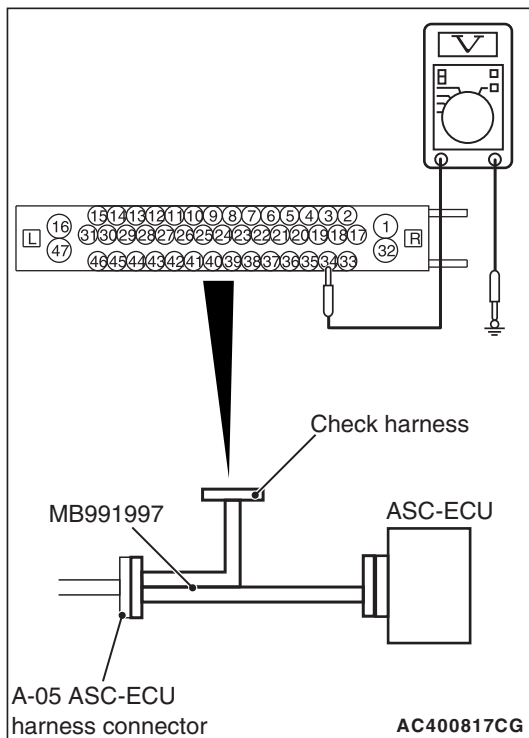

STEP 10. Wiring harness check between A-05 ASC-ECU connector terminal No. 34 and A-03 wheel speed sensor <FR> connector terminal No. 1, and between A-05 ASC-ECU connector terminal No. 33 and A-03 wheel speed sensor <FR> connector terminal No. 2

- Open circuit check of wheel speed sensor <FR> circuit

Q: Is the check result normal?

YES : Go to Step 11.

NO : Repair the wiring harness. Then go to Step 17.

STEP 11. Check of wheel speed sensor as a single unit

Refer to [P.35C-303](#).

Q: Is the check result normal?

YES : Go to Step 13.

NO : Replace the wheel speed sensor <FR>. (Refer to [P.35C-300](#).) Then go to Step 17.

STEP 12. Connector check: A-05 ASC-ECU connector, A-03 wheel speed sensor <FR> connector**Q: Is the check result normal?**

YES : Go to Step 16.

NO : Repair the defective connector. Then go to Step 17.

STEP 13. Check of wheel speed sensor installation status

Check the installation status of wheel speed sensor <FR> (disconnection of wheel speed sensor, looseness of mounting bolt, etc.).

Q: Is the check result normal?

YES : Go to Step 14.

NO : Reinstall the wheel speed sensor <FR> correctly. (Refer to [P.35C-300](#).) Then go to Step 17.

STEP 14. Wheel bearing looseness check**NOTE:**

- Wheel bearing looseness may increase the gap between the wheel speed sensor and the wheel speed detection magnet encoder.
- Check the wheel bearing <FR> for looseness. (Refer to GROUP 26 –On-vehicle Service [P.26-7](#).)

Q: Is the check result normal?

YES : Go to Step 15.

NO : Replace the front hub assembly. (Refer to GROUP 26 –Front Axle Hub Assembly [P.26-9](#).)

STEP 15. Check of wheel speed detection encoder

Check the encoder for adhesion of foreign materials or deformation.

Q: Is the check result normal?

YES : Go to Step 16.

NO (Adhesion of foreign materials) : Clean the encoder so as not to disturb the magnetization pattern on the encoder while taking care of the magnet, magnetic substance, and magnetic attraction.

NO (Deformation) : Replace the front hub assembly. (Refer to GROUP 26 –Front Axle Hub Assembly [P.26-9](#).)

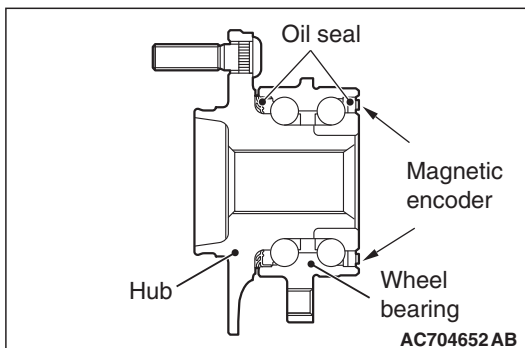

STEP 16. Check whether the DTC is reset.

Drive the vehicle at 12mph (20 km/h) or more.

NOTE: The ABS warning light does not turn OFF in some cases unless the vehicle runs at 12mph (20 km/h) or higher.

Q: Is DTC C1047 set?

YES : Replace the hydraulic unit (incorporates in ASC-ECU).(Refer to P.35C-298.) Then go to Step 17.

NO : Intermittent malfunction. (Refer to GROUP 00 –How to Cope with Intermittent Malfunction P.00-15.)

STEP 17. Check whether the DTC is reset.

Drive the vehicle at 12mph (20 km/h) or more.

NOTE: The ABS warning light does not turn OFF in some cases unless the vehicle runs at 12mph (20 km/h) or higher.

Q: Is DTC C1047 set?

YES : Return to Step 1.

NO : This diagnosis is complete.

DTC C1048: RL wheel speed sensor control phase time exceeded

Wheel Speed Sensor Circuit

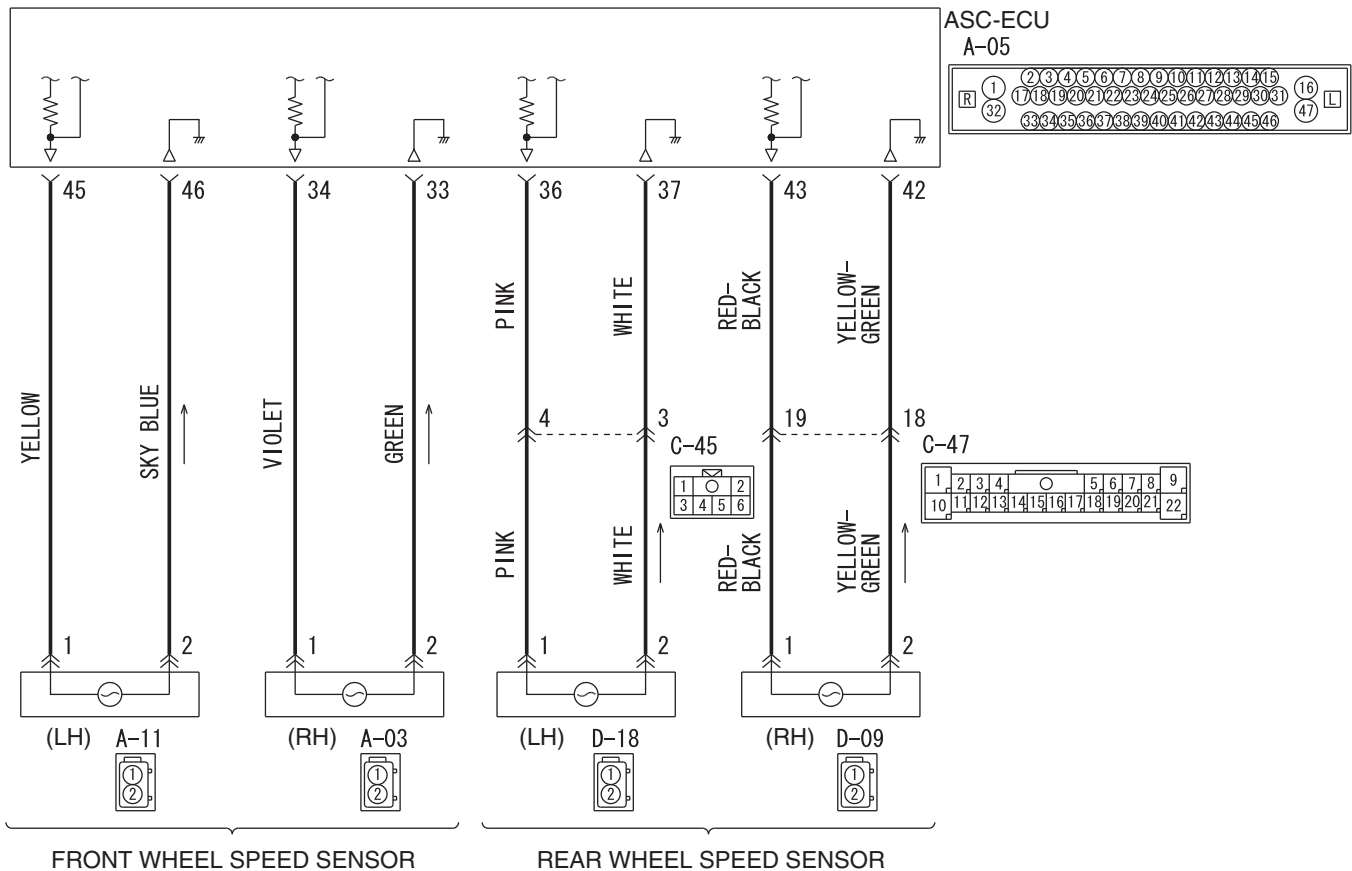

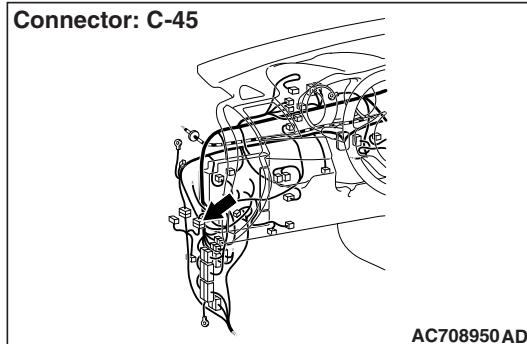
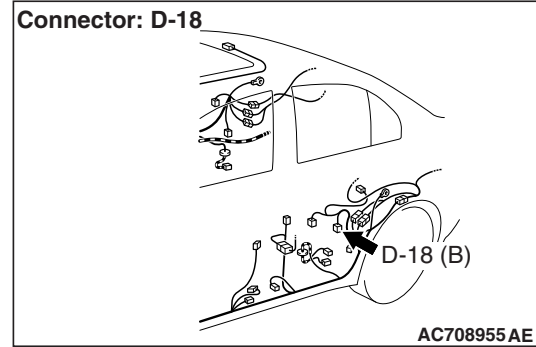
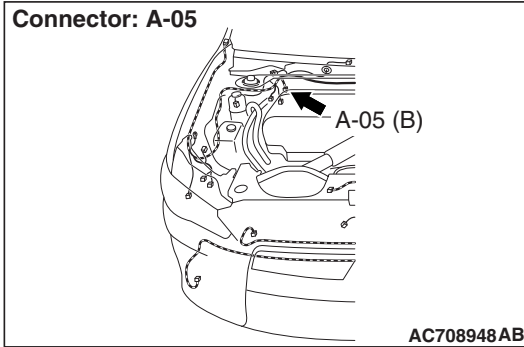

⚠ CAUTION

- If there is any problem in the CAN bus lines, an incorrect diagnostic trouble code may be set. Prior to this diagnosis, diagnose the CAN bus lines.
- Whenever the ECU is replaced, ensure that the CAN bus lines are normal.
- When the hydraulic unit (integrated with ASC-ECU) is replaced, always perform the calibration of steering wheel sensor, G and yaw rate sensor, brake fluid pressure sensor, cut valve, and inlet valve. (Refer to [P.35C-287](#), [P.35C-289](#), [P.35C-294](#), and [P.35C-295](#).)

CIRCUIT OPERATION

- Each wheel speed detecting section is a kind of a pulse generator. It consists of the encoder (plate on which the north and south pole of magnet are arranged alternately) for detecting the wheel speed, which rotates at the same speed of the wheels, and the wheel speed sensor. This detecting section outputs the frequency pulse signals in proportion to the wheel speed.
- The pulse signals generated by the wheel speed detecting section are sent to ASC-ECU. ASC-ECU uses the frequency of the pulse signals to determine the wheel speed.

DTC SET CONDITIONS

This diagnostic trouble code is set if any malfunction below is detected.

- When the brake fluid pressure is decreased for a long time.
- When the brake fluid pressure is held for a long time.

NOTE: ASC controls the vehicle based on the wheel speed signal. When the brake fluid pressure is decreased or held for an abnormally long time, the wheel speed sensor signal may have a problem.

PROBABLE CAUSES

- Damaged wiring harness and connectors
- External noise interference
- Malfunction of wheel speed sensor
- ABS-ECU malfunction
- Excessive gap between the wheel speed sensor and the wheel speed detection encoder
- Adhesion of foreign materials on the wheel speed sensor
- Adhesion of foreign materials on the wheel speed detection encoder
- Wheel bearing malfunction
- Improper installation of the wheel speed sensor
- Deformation of the wheel speed detection encoder
- Disturbance of magnetization pattern for wheel speed detection encoder
- Missing teeth of the wheel speed detection encoder

DIAGNOSIS

Required Special Tools:

- MB991958 Scan Tool (M.U.T.-III Sub Assembly)
 - MB991824: Vehicle Communication Interface (V.C.I.)
 - MB991827 M.U.T.-III USB Cable
 - MB991910 M.U.T.-III Main Harness A
- MB991997: ASC check harness

STEP 1. Using scan tool MB991958, diagnose the CAN bus lines.

Using scan tool MB991958, diagnose the CAN bus lines.

Q: Is the check result normal?

YES : Go to Step 3.

NO : Repair the CAN bus lines. (Refer to GROUP 54C – Troubleshooting [P.54C-15.](#)) After repairing the CAN bus line, go to Step 2.

STEP 2. DTC recheck after repairing the CAN bus line

Q: Is DTC C1048 set?

YES : Go to Step 3.

NO : This diagnosis is complete.

STEP 3. Scan tool diagnostic trouble code

Check that DTC No. C1020, C1027, C102A, and C1043 are simultaneously set.

Q: Are DTC C1020, C1027, C102A and C1043 also set?

YES : Carry out the diagnosis for the diagnostic trouble codes that are set, and then go to Step 5.

NO : Go to Step 4.

STEP 4. Scan tool service data

Check the following service data. (Refer to P.35C-276.)

- Item No.03: RL wheel speed sensor

Q: Is the check result normal?

YES : Go to Step 16.

NO : Go to Step 5.

STEP 5. Voltage measurement at A-05 ASC-ECU connector

- (1) Disconnect the ASC-ECU connector, connect the special tool ASC check harness (MB991997) to the wiring harness-side connector, and then measure at the special tool connector side.

NOTE: Do not connect the special tool to ASC-ECU.

- (2) Turn the ignition switch to the ON position.
- (3) Measure the voltage between the wheel speed sensor power supply terminal (signal terminal) No. 36 and the body ground as well as between the ground terminal No. 37 and the body ground.

OK: 1 volt or less

Q: Is the check result normal?

YES : Go to Step 6.

NO (Not normal at terminal No. 34 or 33) : Go to Step 7.

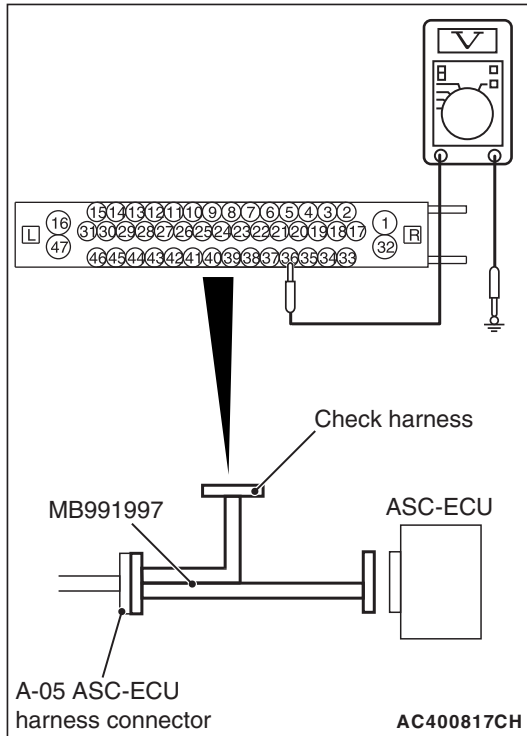

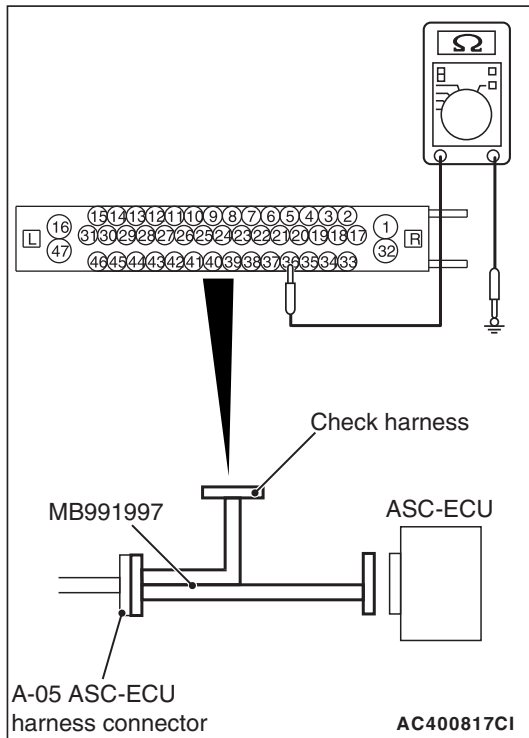

STEP 6. Resistance measurement at A-05 ASC-ECU connector

- (1) Disconnect the ASC-ECU connector, connect the special tool ASC check harness (MB991997) to the wiring harness-side connector, and then measure at the special tool connector side.

NOTE: Do not connect the special tool to ASC-ECU.

- (2) Measure the resistance between the wheel speed sensor circuit power supply terminal (signal terminal) No. 36 and the body ground as well as between the ground terminal No. 37 and the body ground.

OK: No continuity

Q: Is the check result normal?

YES : Go to Step 9.

NO (Not normal at the terminal No. 36 or 37) : Go to Step 7.

STEP 7. Connector check: A-05 ASC-ECU connector, C-45 intermediate connector, D-18 wheel speed sensor <RL> connector

Q: Is the check result normal?

YES : Go to Step 8.

NO : Repair the defective connector. Then go to Step 17.

STEP 8. Wiring harness check between A-05 ASC-ECU connector terminal No. 36 and D-18 wheel speed sensor <RL> connector terminal No. 1, and between A-05 ASC-ECU connector terminal No. 37 and D-18 wheel speed sensor <RL> connector terminal No. 2

- Short circuit check of wheel speed sensor <RL> circuit

Q: Is the check result normal?

YES : Replace the wheel speed sensor <RL>. (Refer to [P.35C-300.](#)) Then go to Step 17.

NO : Repair the wiring harness. Then go to Step 17.

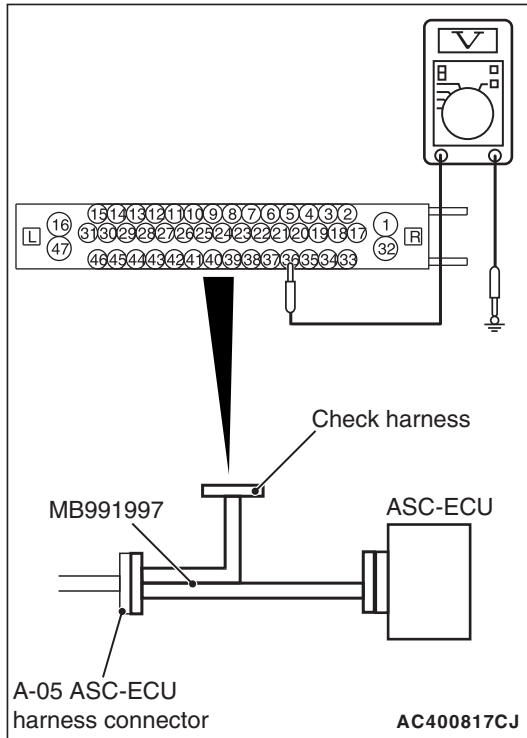
**STEP 9. Voltage measurement at A-05 ASC-ECU connector**

- (1) Disconnect the ASC-ECU connector, connect the special tool ASC check harness (MB991997) to the ASC-ECU-side connector and the wiring harness-side connector, and then measure at the special tool connector side.
- (2) Turn the ignition switch to the ON position.
- (3) Measure the voltage between the wheel speed sensor circuit power supply terminal (signal terminal) No. 36 and the body ground.

OK: Battery positive voltage

Q: Is the check result normal?

YES : Go to Step 10.

NO : Go to Step 12.

STEP 10. Wiring harness check between A-05 ASC-ECU connector terminal No. 36 and D-18 wheel speed sensor <RL> connector terminal No. 1, and between A-05 ASC-ECU connector terminal No. 37 and D-18 wheel speed sensor <RL> connector terminal No. 2

- Open circuit check of wheel speed sensor <RL> circuit

Q: Is the check result normal?

YES : Go to Step 11.

NO : Repair the wiring harness. Then go to Step 17.

STEP 11. Check of wheel speed sensor as a single unit

Refer to [P.35C-303](#).

Q: Is the check result normal?

YES : Go to Step 13.

NO : Replace the wheel speed sensor <RL>. (Refer to [P.35C-300](#).) Then go to Step 17.

STEP 12. Connector check: A-05 ASC-ECU connector, C-45 intermediate connector, D-18 wheel speed sensor <RL> connector

Q: Is the check result normal?

YES : Go to Step 16.

NO : Repair the defective connector. Then go to Step 17.

STEP 13. Check of wheel speed sensor installation status

Check the installation status of wheel speed sensor <RL> (disconnection of wheel speed sensor, looseness of mounting bolt, etc.).

Q: Is the check result normal?

YES : Go to Step 14.

NO : Reinstall the wheel speed sensor <RL> correctly. (Refer to P.35C-300.) Then go to Step 17.

STEP 14. Wheel bearing looseness check

NOTE:

- Wheel bearing looseness may increase the gap between the wheel speed sensor and the wheel speed detection magnet encoder.
- Check the wheel bearing <RL> for looseness. (Refer to GROUP 27 –On-vehicle Service P.27-32.)

Q: Is the check result normal?

YES : Go to Step 15.

NO : Replace the rear wheel hub assembly. (Refer to GROUP 27 –Rear Axle Hub Assembly P.27-35.)

STEP 15. Check of wheel speed detection encoder

Check the encoder for adhesion of foreign materials or deformation.

Q: Is the check result normal?

YES : Go to Step 16.

NO (Adhesion of foreign materials) : Clean the encoder so as not to disturb the magnetization pattern on the encoder while taking care of the magnet, magnetic substance, and magnetic attraction.

NO (Deformation) : Replace the rear wheel hub assembly. (Refer to GROUP 27 –Rear Axle Hub Assembly P.27-35.)

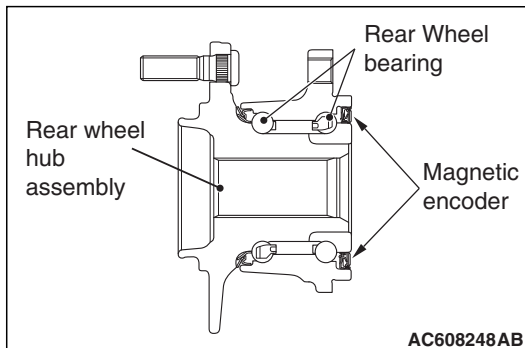

STEP 16. Check whether the DTC is reset.

Drive the vehicle at 12mph (20 km/h) or more.

NOTE: The ABS warning light does not turn OFF in some cases unless the vehicle runs at 12mph (20 km/h) or higher.

Q: Is DTC C1048 set?

YES : Replace the hydraulic unit (incorporates in ASC-ECU).(Refer to P.35C-298.) Then go to Step 17.

NO : Intermittent malfunction. (Refer to GROUP 00 –How to Cope with Intermittent Malfunction P.00-15.)

STEP 17. Check whether the DTC is reset.

Drive the vehicle at 12mph (20 km/h) or more.

NOTE: The ABS warning light does not turn OFF in some cases unless the vehicle runs at 12mph (20 km/h) or higher.

Q: Is DTC C1048 set?

YES : Return to Step 1.

NO : This diagnosis is complete.

DTC C1049: RR wheel speed sensor control phase time exceeded

Wheel Speed Sensor Circuit

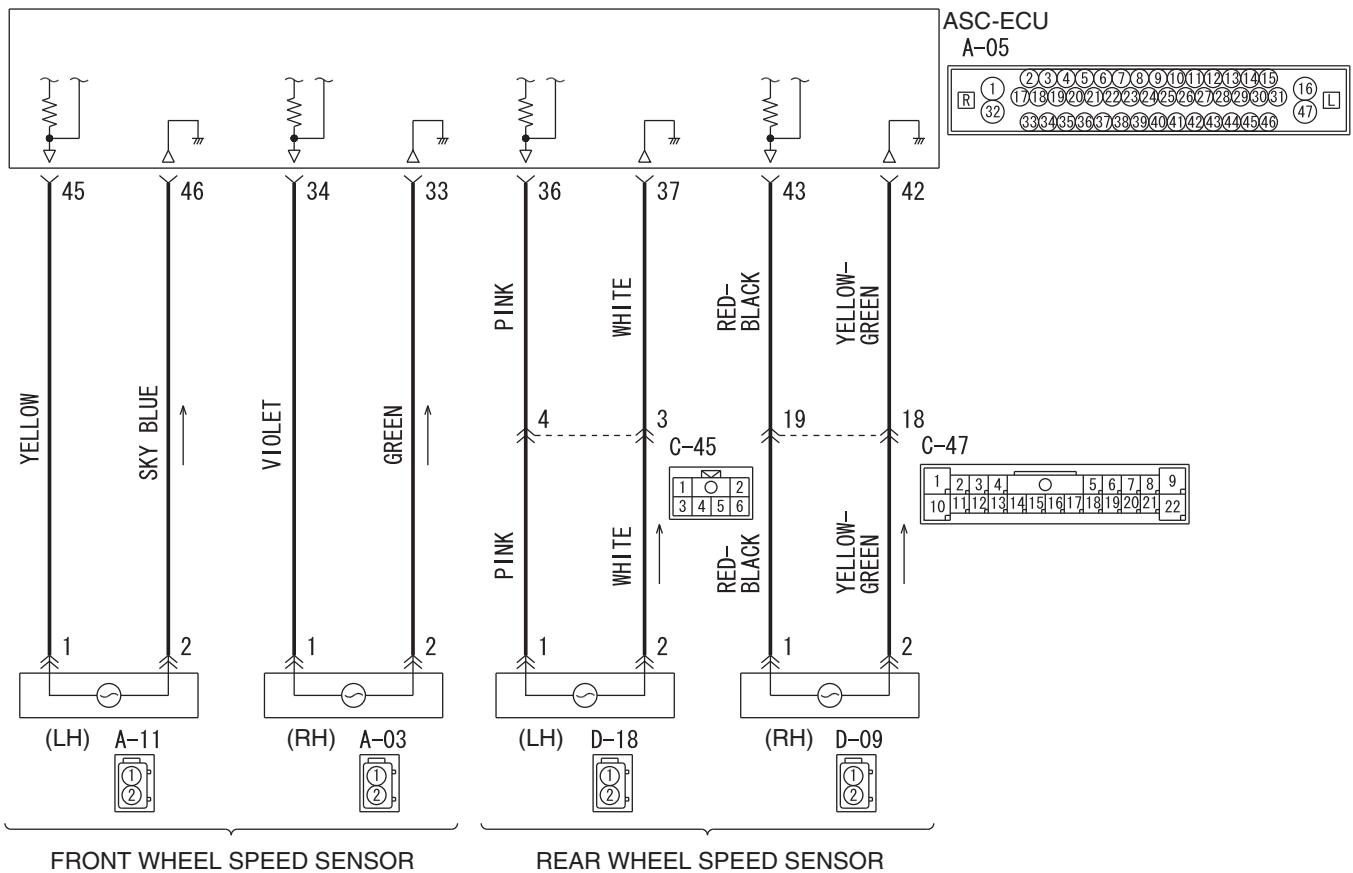

AC804587

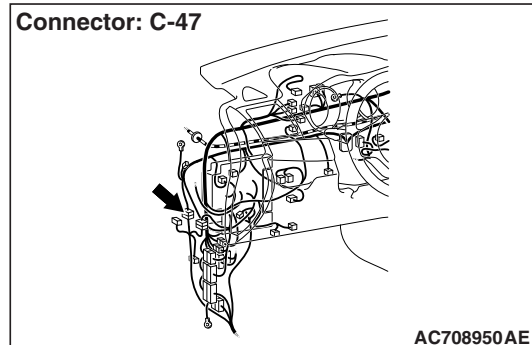
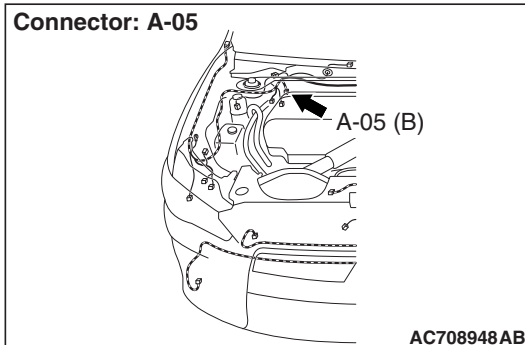

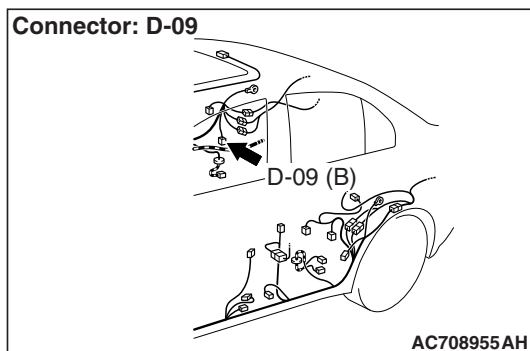

⚠ CAUTION

- If there is any problem in the CAN bus lines, an incorrect diagnostic trouble code may be set. Prior to this diagnosis, diagnose the CAN bus lines.
- Whenever the ECU is replaced, ensure that the CAN bus lines are normal.
- When the hydraulic unit (integrated with ASC-ECU) is replaced, always perform the calibration of steering wheel sensor, G and yaw rate sensor, brake fluid pressure sensor, cut valve, and inlet valve. (Refer to [P.35C-287](#), [P.35C-289](#), [P.35C-294](#), and [P.35C-295](#).)

CIRCUIT OPERATION

- Each wheel speed detecting section is a kind of a pulse generator. It consists of the encoder (plate on which the north and south pole of magnet are arranged alternately) for detecting the wheel speed, which rotates at the same speed of the wheels, and the wheel speed sensor. This detecting section outputs the frequency pulse signals in proportion to the wheel speed.
- The pulse signals generated by the wheel speed detecting section are sent to ASC-ECU. ASC-ECU uses the frequency of the pulse signals to determine the wheel speed.

DTC SET CONDITIONS

This diagnostic trouble code is set if any malfunction below is detected.

- When the brake fluid pressure is decreased for a long time.
- When the brake fluid pressure is held for a long time.

NOTE: ASC controls the vehicle based on the wheel speed signal. When the brake fluid pressure is decreased or held for an abnormally long time, the wheel speed sensor signal may have a problem.

PROBABLE CAUSES

- Damaged wiring harness and connectors
- External noise interference
- Malfunction of wheel speed sensor
- ABS-ECU malfunction

- Excessive gap between the wheel speed sensor and the wheel speed detection encoder
- Adhesion of foreign materials on the wheel speed sensor
- Adhesion of foreign materials on the wheel speed detection encoder
- Wheel bearing malfunction
- Improper installation of the wheel speed sensor
- Deformation of the wheel speed detection encoder
- Disturbance of magnetization pattern for wheel speed detection encoder
- Missing teeth of the wheel speed detection encoder

DIAGNOSIS

Required Special Tools:

- MB991958 Scan Tool (M.U.T.-III Sub Assembly)
 - MB991824: Vehicle Communication Interface (V.C.I.)
 - MB991827 M.U.T.-III USB Cable
 - MB991910 M.U.T.-III Main Harness A
- MB991997: ASC check harness

STEP 1. Using scan tool MB991958, diagnose the CAN bus lines.

Using scan tool MB991958, diagnose the CAN bus lines.

Q: Is the check result normal?

YES : Go to Step 3.

NO : Repair the CAN bus lines. (Refer to GROUP 54C – Troubleshooting [P.54C-15](#).) After repairing the CAN bus line, go to Step 2.

STEP 2. DTC recheck after repairing the CAN bus line

Q: Is DTC C1049 set?

YES : Go to Step 3.

NO : This diagnosis is complete.

STEP 3. Scan tool diagnostic trouble code

Check whether DTC No. C102B, C1032, C1035, and C1044 are simultaneously set.

Q: Are DTC C102B, C1032, C1035 and C1044 also set?

YES : Carry out the diagnosis for the diagnostic trouble codes that are set, and then go to Step 5.

NO : Go to Step 4.

STEP 4. Scan tool service data

Check the following service data. (Refer to [P.35C-276](#).)

- Item No.04: RR wheel speed sensor

Q: Is the check result normal?

YES : Go to Step 16.

NO : Go to Step 5.

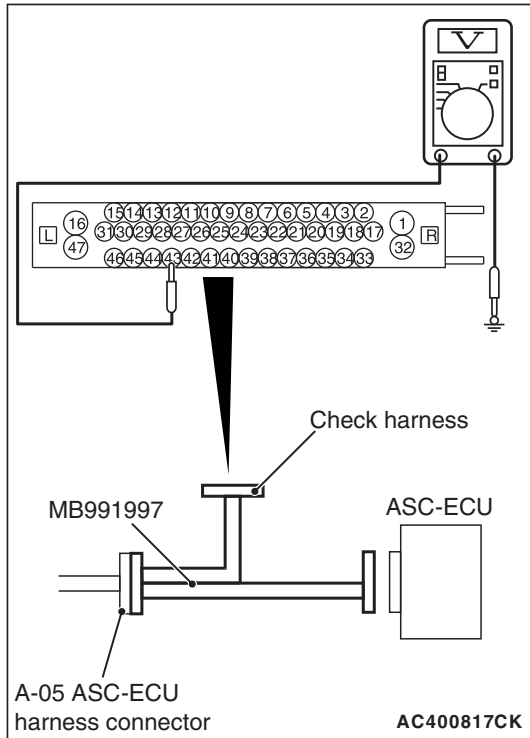

STEP 5. Voltage measurement at A-05 ASC-ECU connector

- (1) Disconnect the ASC-ECU connector, connect the special tool ASC check harness (MB991997) to the wiring harness-side connector, and then measure at the special tool connector side.

NOTE: Do not connect the special tool to ASC-ECU.

- (2) Turn the ignition switch to the ON position.
- (3) Measure the voltage between the wheel speed sensor power supply terminal (signal terminal) No. 43 and the body ground as well as between the ground terminal No. 42 and the body ground.

OK: 1 volt or less

Q: Is the check result normal?

YES : Go to Step 6.

NO (Not normal at the terminal No. 43 or 42) : Go to Step 7.

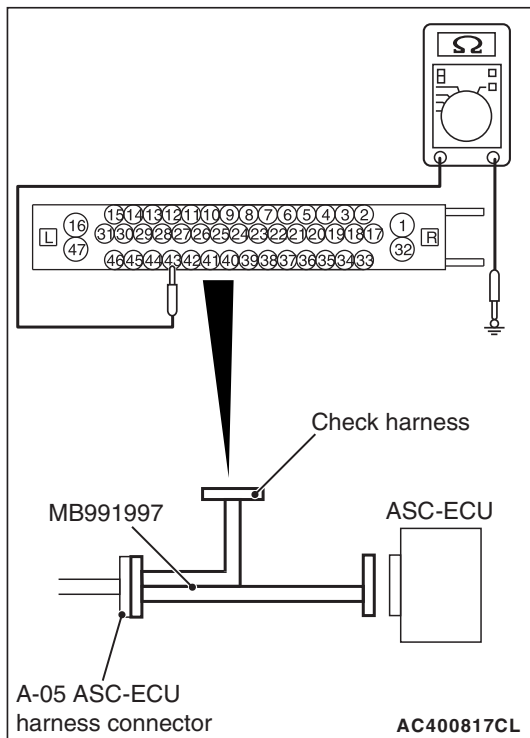

STEP 6. Resistance measurement at A-05 ASC-ECU connector

- (1) Disconnect the ASC-ECU connector, connect the special tool ASC check harness (MB991997) to the wiring harness-side connector, and then measure at the special tool connector side.

NOTE: Do not connect the special tool to ASC-ECU.

- (2) Measure the resistance between the wheel speed sensor circuit power supply terminal (signal terminal) No. 43 and the body ground as well as between the ground terminal No. 42 and the body ground.

OK: No continuity

Q: Is the check result normal?

YES : Go to Step 9.

NO (Not normal at the terminal No. 43 or 42) : Go to Step 7.

STEP 7. Connector check: A-05 ASC-ECU connector, C-47 intermediate connector, D-09 wheel speed sensor <RR> connector

Q: Is the check result normal?

YES : Go to Step 8.

NO : Repair the defective connector. Then go to Step 17.

STEP 8. Wiring harness check between A-05 ASC-ECU connector terminal No. 43 and D-09 wheel speed sensor <RR> connector terminal No. 1, and between A-05 ASC-ECU connector terminal No. 42 and D-09 wheel speed sensor <RR> connector terminal No. 2

- Short circuit check of wheel speed sensor <RR> circuit

Q: Is the check result normal?

YES : Replace the wheel speed sensor <RR>. (Refer to [P.35C-300.](#)) Then go to Step 17.

NO : Repair the wiring harness. Then go to Step 17.

STEP 9. Voltage measurement at A-05 ASC-ECU connector

- (1) Disconnect the ASC-ECU connector, connect the special tool ASC check harness (MB991997) to the ASC-ECU-side connector and the wiring harness-side connector, and then measure at the special tool connector side.
- (2) Turn the ignition switch to the ON position.
- (3) Measure the voltage between the wheel speed sensor circuit power supply terminal (signal terminal) No. 43 and the body ground.

OK: Battery positive voltage

Q: Is the check result normal?

YES : Go to Step 10.

NO : Go to Step 12.

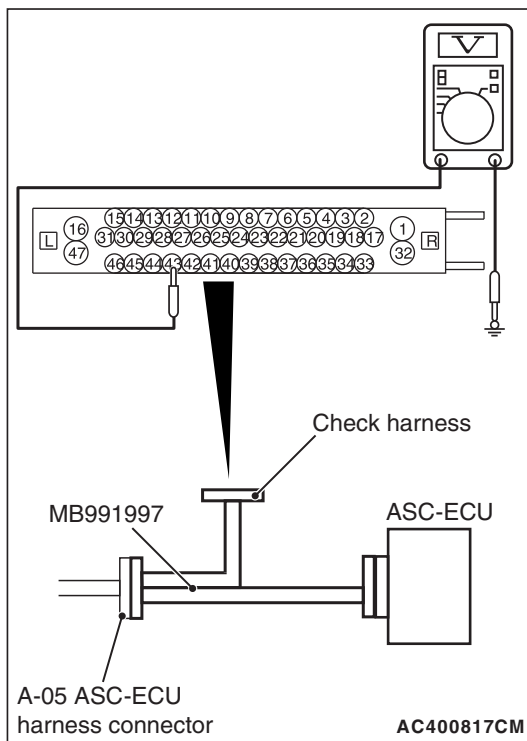

STEP 10. Wiring harness check between A-05 ASC-ECU connector terminal No. 43 and D-09 wheel speed sensor <RR> connector terminal No. 1, and between A-05 ASC-ECU connector terminal No. 42 and D-09 wheel speed sensor <RR> connector terminal No. 2

- Open circuit check of wheel speed sensor <RR> circuit

Q: Is the check result normal?

YES : Go to Step 11.

NO : Repair the wiring harness. Then go to Step 17.

STEP 11. Check of wheel speed sensor as a single unit
Refer to [P.35C-303](#).

Q: Is the check result normal?

YES : Go to Step 13.

NO : Replace the wheel speed sensor <RR>. (Refer to [P.35C-300](#).) Then go to Step 17.

STEP 12. Connector check: A-05 ASC-ECU connector, C-47 intermediate connector, D-09 wheel speed sensor <RR> connector

Q: Is the check result normal?

YES : Go to Step 16.

NO : Repair the defective connector. Then go to Step 17.

STEP 13. Check of wheel speed sensor installation status
Check the installation status of wheel speed sensor <RR> (disconnection of wheel speed sensor, looseness of mounting bolt, etc.).

Q: Is the check result normal?

YES : Go to Step 14.

NO : Reinstall the wheel speed sensor <RR> correctly. (Refer to [P.35C-300](#).) Then go to Step 17.

STEP 14. Wheel bearing looseness check

NOTE:

- Wheel bearing looseness may increase the gap between the wheel speed sensor and the wheel speed detection magnet encoder.
- Check the wheel bearing <RR> for looseness. (Refer to GROUP 27 –On-vehicle Service [P.27-32](#).)

Q: Is the check result normal?

YES : Go to Step 15.

NO : Replace the rear wheel hub assembly. (Refer to GROUP 27 –Rear Axle Hub Assembly [P.27-35](#).)

STEP 15. Check of wheel speed detection encoder

Check the encoder for adhesion of foreign materials or deformation.

Q: Is the check result normal?

YES : Go to Step 16.

NO (Adhesion of foreign materials) : Clean the encoder so as not to disturb the magnetization pattern on the encoder while taking care of the magnet, magnetic substance, and magnetic attraction.

NO (Deformation) : Replace the rear hub assembly. (Refer to GROUP 27 –Rear Axle Hub Assembly [P.27-35](#).)

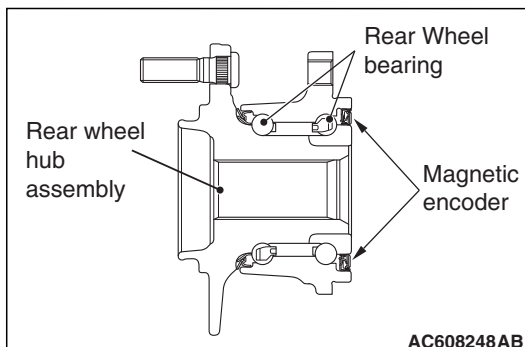

STEP 16. Check whether the DTC is reset.

Drive the vehicle at 12mph (20 km/h) or more.

NOTE: The ABS warning light does not turn OFF in some cases unless the vehicle runs at 12mph (20 km/h) or higher.

Q: Is DTC C1049 set?

YES : Replace the hydraulic unit (incorporates in ASC-ECU).(Refer to [P.35C-298.](#)) Then go to Step 17.

NO : Intermittent malfunction. (Refer to GROUP 00 –How to Cope with Intermittent Malfunction [P.00-15.](#))

STEP 17. Check whether the DTC is reset.

Drive the vehicle at 12mph (20 km/h) or more.

NOTE: The ABS warning light does not turn OFF in some cases unless the vehicle runs at 12mph (20 km/h) or higher.

Q: Is DTC C1049 set?

YES : Return to Step 1.

NO : This diagnosis is complete.

DTC C104B: Abnormality in FL wheel inlet valve system
 DTC C104F: Abnormality in FR wheel inlet valve system
 DTC C1053: Abnormality in RL wheel inlet valve system
 DTC C1057: Abnormality in RR wheel inlet valve system
 DTC C105F: Abnormality in FL wheel outlet valve system
 DTC C1063: Abnormality in FR wheel outlet valve system
 DTC C1067: Abnormality in RL wheel outlet valve system
 DTC C105B: Abnormality in RR wheel outlet valve system
 DTC C1200: Abnormality in FL/RR wheel cut valve system
 DTC C1204: Abnormality in FR/RL wheel cut valve system
 DTC C1208: Abnormality in FL/RR wheel suction valve system
 DTC C120C: Abnormality in FR/RL wheel suction valve system

⚠ CAUTION

- If there is any problem in the CAN bus lines, an incorrect diagnostic trouble code may be set. Prior to this diagnosis, diagnose the CAN bus lines.
- Whenever the ECU is replaced, ensure that the CAN bus lines are normal.
- When the hydraulic unit (integrated with ASC-ECU) is replaced, always perform the calibration of steering wheel sensor, G and yaw rate sensor, brake fluid pressure sensor, cut valve, and inlet valve.(Refer to [P.35C-287](#), [P.35C-289](#), [P.35C-294](#), and [P.35C-295.](#))

CIRCUIT OPERATION

- ASC-ECU contains the power supply circuit (terminal No. 32) for the solenoid valve. The solenoid valve is energized by the valve relay, which is incorporated in ASC-ECU.

- The valve relay in ASC-ECU is energized at all times, and the solenoid valve is always energized while the system is in operation unless the initial check is in progress when the ignition switch is turned ON, or unless the periodical system check is in progress.
- ASC-ECU activates the solenoid valve by turning on its driving transistor.

DTC SET CONDITIONS

These diagnostic trouble codes are set under the cases below.

- The solenoid valve is not energized even after ASC-ECU has turned on the driving transistor. (Open circuit is present in the power supply circuit to ASC-ECU solenoid valve or ASC-ECU solenoid valve circuit, or the valve relay has failed.)
- The solenoid valve still remains energized even after ASC-ECU has turned off the driving transistor. (Short circuit in the solenoid valve circuit.)
- When a solenoid valve failure is detected

PROBABLE CAUSES

ASC-ECU malfunction

DIAGNOSIS

Required Special Tools:

- MB991958 Scan Tool (M.U.T.-III Sub Assembly)
 - MB991824: Vehicle Communication Interface (V.C.I.)
 - MB991827 M.U.T.-III USB Cable
 - MB991910 M.U.T.-III Main Harness A
- MB991997: ASC check harness

STEP 1. Using scan tool MB991958, diagnose the CAN bus lines.

Using scan tool MB991958, diagnose the CAN bus lines.

Q: Is the check result normal?

YES : Go to Step 3.

NO : Repair the CAN bus lines. (Refer to GROUP 54C – Troubleshooting [P.54C-15](#).) After repairing the CAN bus line, go to Step 2.

STEP 2. DTC recheck after repairing the CAN bus line

Q: Are DTC C104B, C104F, C1053, C1057, C105F, C1063, C1067, C105B, C1200, C1204, C1208 or C120C set?

YES : Go to Step 3.

NO : This diagnosis is complete.

STEP 3. Check whether the DTC is reset.

Q: Are DTC C104B, C104F, C1053, C1057, C105F, C1063, C1067, C105B, C1200, C1204, C1208 or C120C set?

YES : Replace the hydraulic unit (incorporates in ASC-ECU).(Refer to P.35C-298.) Then go to Step 4.

NO : Intermittent malfunction. (Refer to GROUP 00 –How to Cope with Intermittent Malfunction P.00-15.)

STEP 4. Check whether the DTC is reset.

Q: Are DTC C104B, C104F, C1053, C1057, C105F, C1063, C1067, C105B, C1200, C1204, C1208 or C120C set?

YES : Return to Step 1.

NO : This diagnosis is complete.

DTC C2104: Faulty valve power supply circuit

Solenoid Valve Power Supply Circuit

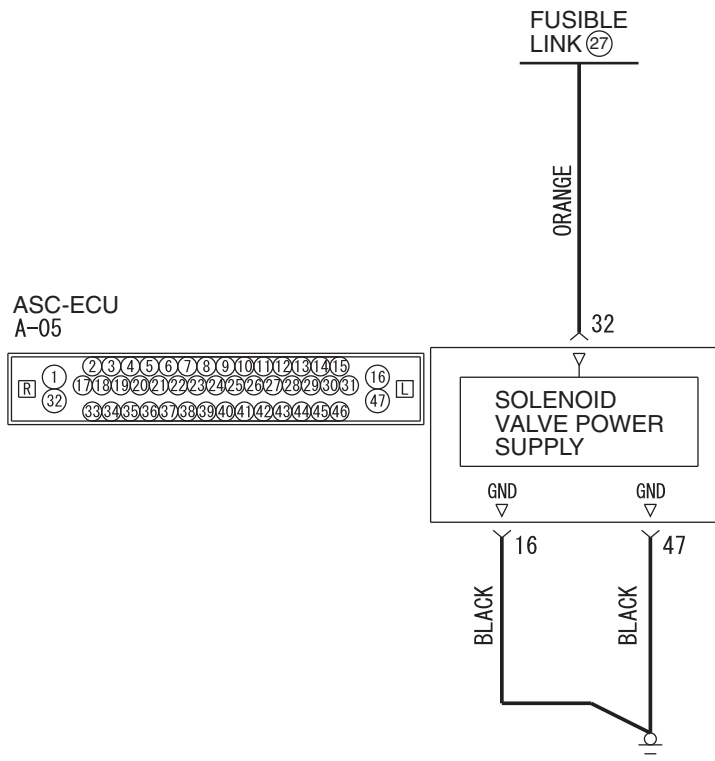

AC804600

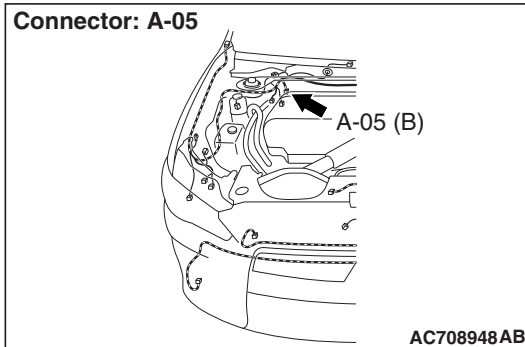

⚠ CAUTION

- If there is any problem in the CAN bus lines, an incorrect diagnostic trouble code may be set. Prior to this diagnosis, diagnose the CAN bus lines.
- Whenever the ECU is replaced, ensure that the CAN bus lines are normal.
- When the hydraulic unit (integrated with ASC-ECU) is replaced, always perform the calibration of steering wheel sensor, G and yaw rate sensor, brake fluid pressure sensor, cut valve, and inlet valve. (Refer to [P.35C-287](#), [P.35C-289](#), [P.35C-294](#), and [P.35C-295](#).)

CIRCUIT OPERATION

- ASC-ECU contains the power supply circuit (terminal No. 32) for the solenoid valve. The solenoid valve is energized by the valve relay, which is incorporated in ASC-ECU.
- The valve relay in ASC-ECU is energized at all times, and the solenoid valve is always energized while the system is in operation unless the initial check is in progress when the ignition switch is turned ON, or unless the periodical system check is in progress.

DTC SET CONDITIONS

This diagnostic trouble code is set when the solenoid valve supply voltage is out of the standard value.

PROBABLE CAUSES

Current trouble

- Fusible link malfunction
- Damaged wiring harness and connectors
- Abnormality in battery or generator
- ASC-ECU malfunction

Past trouble

- Carry out the diagnosis with a particular emphasis on the wiring harness and connector failures in the ASC-ECU solenoid valve power supply circuit (terminal No. 32) and in the ground circuit (terminal No. 16 and No. 47). For diagnosis procedures, refer to How to Treat Past Trouble (GROUP 00 –How to Use Troubleshooting/Inspection Service Points [P.00-16](#)).

DIAGNOSIS**Required Special Tools:**

- MB991958 Scan Tool (M.U.T.-III Sub Assembly)
 - MB991824: Vehicle Communication Interface (V.C.I.)
 - MB991827 M.U.T.-III USB Cable
 - MB991910 M.U.T.-III Main Harness A
- MB991997: ASC check harness

STEP 1. Using scan tool MB991958, diagnose the CAN bus lines.

Using scan tool MB991958, diagnose the CAN bus lines.

Q: Is the check result normal?

YES : Go to Step 3.

NO : Repair the CAN bus lines (Refer to GROUP 54C – CAN Bus Diagnostics table [P.54C-9](#)). On completion, go to Step 2.

STEP 2. DTC recheck after repairing the CAN bus line**Q: Is DTC C2104 set?**

YES : Go to Step 3.

NO : This diagnosis is complete.

STEP 3. Battery check

Refer to GROUP 54A –Battery Test [P.54A-9](#).

Q: Is the battery in good condition?

YES : Go to Step 4.

NO : Replace the battery. Then go to Step 11.

STEP 4. Charging system check

Refer to GROUP 16 –Output Current Test [P.16-8](#).

Q: Is the charging system in good condition?

YES : Go to Step 5.

NO : Repair or replace the charging system component(s). Then go to Step 11.

STEP 5. Connector check: A-05 ASC-ECU connector**Q: Is the check result normal?**

YES : Go to Step 6.

NO : Repair the defective connector. Then go to Step 11.

STEP 6. Fusible link check: Check the fusible link No.27.

Visually check for open circuit in the fusible link No.27.

Q: Is the check result normal?

YES : Go to Step 8.

NO : Go to Step 7.

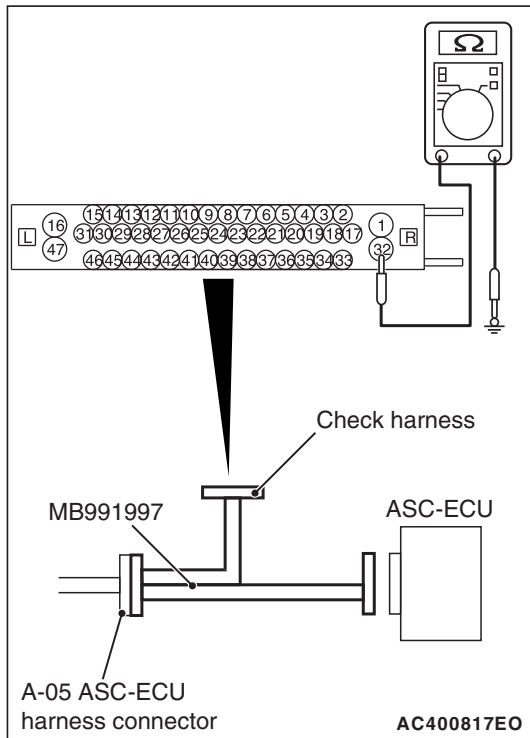

STEP 7. Resistance measurement at A-05 ASC-ECU connector

(1) Disconnect the ASC-ECU connector, connect special tool ASC check harness (MB991997) to the harness-side connector, and then measure the resistance at the special tool connector side.

NOTE: Do not connect the special tool ASC check harness (MB991997) to ASC-ECU.

- (2) Disconnect the fusible link No.27.
- (3) Resistance between the terminal No.32 and the body ground.

OK: No continuity

Q: Is the check result normal?

YES : Replace the fusible link No.27. Then go to Step 11.

NO : The short circuit may be present in the power supply circuit. Repair the wiring harness between the A-05 ASC-ECU connector terminal No.32 and the fusible link No.27, and then replace the fusible link No.27. Then go to Step 11.

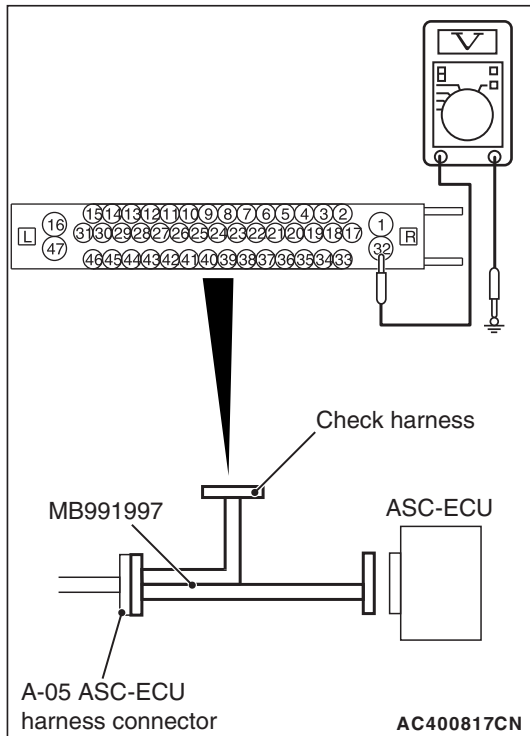

STEP 8. Voltage measurement at A-05 ASC-ECU connector

(1) Disconnect the connector, connect the special tool ASC check harness (MB991997) to the wiring harness-side connector, and measure the voltage at the special tool connector side.

NOTE: Do not connect the special tool to ASC-ECU.

- (2) Measure the voltage between the terminal No. 32 and the body ground.

OK: Battery positive voltage

Q: Is the check result normal?

YES : Go to Step 9.

NO : The open circuit may be present in the power supply circuit. Repair the wiring harness between the A-05 ASC-ECU connector terminal No.32 and the fusible link No.27. Then go to Step 11.

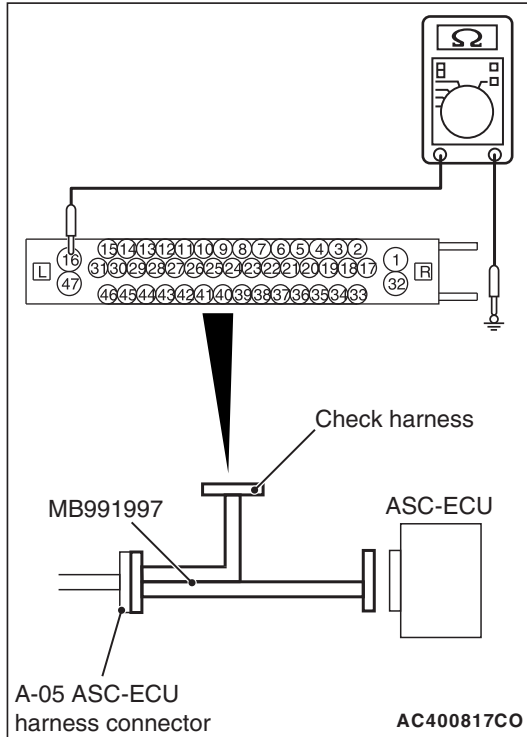
**STEP 9. Resistance measurement at A-05 ASC-ECU connector**

- (1) Disconnect the connector, connect the special tool ASC check harness (MB991997) to the wiring harness-side connector, and measure the voltage at the special tool connector side.

NOTE: Do not connect the special tool to ASC-ECU.

- (2) Measure the resistance between the terminal No. 16 and the body ground as well as between the terminal No. 47 and the body ground.

OK: Continuity exists (2Ω or less)

Q: Is the check result normal?

YES : Go to Step 10.

NO : An open circuit may be present in the ground circuit. Repair the wiring harness between the A-05 ASC-ECU connector terminal No.16 and the body ground, and between the A-05 ASC-ECU connector terminal No.47 and the body ground. Then go to Step 11.

STEP 10. Check whether the DTC is reset.**Q: Is DTC C2104 set?**

YES : Replace the hydraulic unit (incorporates in ASC-ECU).(Refer to [P.35C-298.](#)) Then go to Step 11.

NO : Intermittent malfunction. (Refer to GROUP 00 –How to Cope with Intermittent Malfunction [P.00-15.](#))

STEP 11. Check whether the DTC is reset.**Q: Is DTC C2104 set?**

YES : Return to Step 1.

NO : This diagnosis is complete.

DTC C1073: Faulty motor drive circuit

Motor Power Supply Circuit

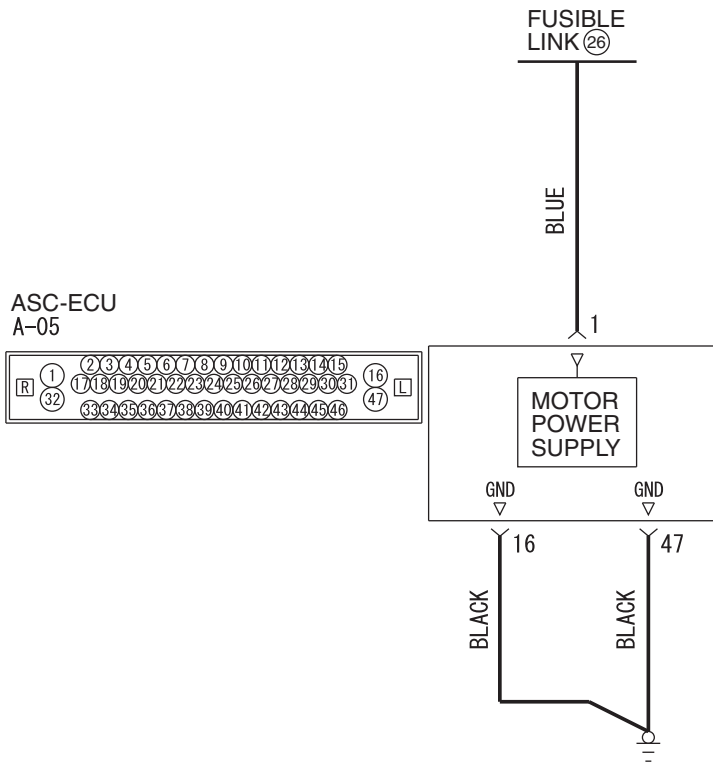

AC804602

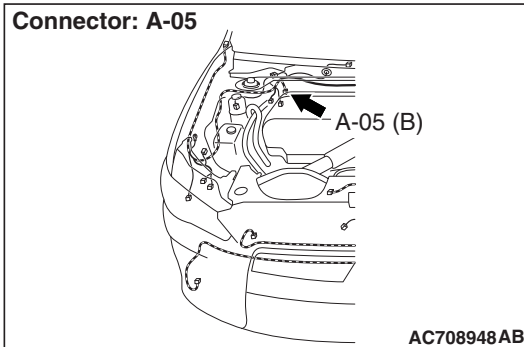

CAUTION

- If there is any problem in the CAN bus lines, an incorrect diagnostic trouble code may be set. Prior to this diagnosis, diagnose the CAN bus lines.
- Whenever the ECU is replaced, ensure that the CAN bus lines are normal.
- When the hydraulic unit (integrated with ASC-ECU) is replaced, always perform the calibration of steering wheel sensor, G and yaw rate sensor, brake fluid pressure sensor, cut valve, and inlet valve.(Refer to [P.35C-287](#), [P.35C-289](#), [P.35C-294](#), and [P.35C-295](#).)

CIRCUIT OPERATION

- ASC-ECU contains the power supply circuit (terminal No. 1) for the motor. The pump motor is energized by the pump motor switch, which is incorporated in ASC-ECU.
- The pump motor switch in ASC-ECU is turned off at all times unless during the motor solenoid valve check performed when the vehicle is started.
- ASC-ECU activates the pump motor by turning on the ECU built-in pump motor switch.

DTC SET CONDITIONS

If the variation of pump motor switch voltage drop during or after the pump motor operation becomes larger than the specified value, the pump motor operation is stopped and this DTC is set.

PROBABLE CAUSES**Current trouble**

- Fusible link malfunction
- Damaged wiring harness and connectors
- Abnormality in battery or generator
- ASC-ECU malfunction

Past trouble

- Perform the diagnosis with a particular emphasis on the wiring harness and connector failures in the ASC-ECU motor power supply circuit (A-05 ASC-ECU connector terminal No. 1) and in the ground circuit (A-05 ASC-ECU connector terminal No. 16 and No.47). For diagnosis procedures, refer to How to Treat Past Trouble (GROUP 00 –How to Use Troubleshooting/Inspection Service Points [P.00-16](#)).

DIAGNOSIS**Required Special Tools:**

- MB991958 Scan Tool (M.U.T.-III Sub Assembly)
 - MB991824: Vehicle Communication Interface (V.C.I.)
 - MB991827 M.U.T.-III USB Cable
 - MB991910 M.U.T.-III Main Harness A
- MB991997: ASC check harness

STEP 1. Using scan tool MB991958, diagnose the CAN bus lines.

Using scan tool MB991958, diagnose the CAN bus lines.

Q: Is the check result normal?

YES : Go to Step 3.

NO : Repair the CAN bus lines (Refer to GROUP 54C – CAN Bus Diagnosis table [P.54C-15](#)). On completion, go to Step 2.

STEP 2. DTC recheck after repairing the CAN bus line

Q: Is DTC C1073 set?

YES : Go to Step 3.

NO : The procedure is complete.

STEP 3. Battery check

Refer to GROUP 54A –Battery Test [P.54A-9](#).

Q: Is the battery in good condition?

YES : Go to Step 4.

NO : Replace the battery. Then go to Step 11.

STEP 4. Charging system check

Refer to GROUP 16 –Output Current Test [P.16-8](#).

Q: Is the charging system in good condition?

YES : Go to Step 5.

NO : Repair or replace the charging system component(s).
Then go to Step 11.

STEP 5. Connector check: A-05 ASC-ECU connector

Q: Is the check result normal?

YES : Go to Step 6.

NO : Repair the defective connector. Then go to Step 11.

STEP 6. Fusible link check: Check the fusible link No. 26.

Visually check for open circuit in the fusible link No.26.

Q: Is the check result normal?

YES : Go to Step 8.

NO : Go to Step 7.

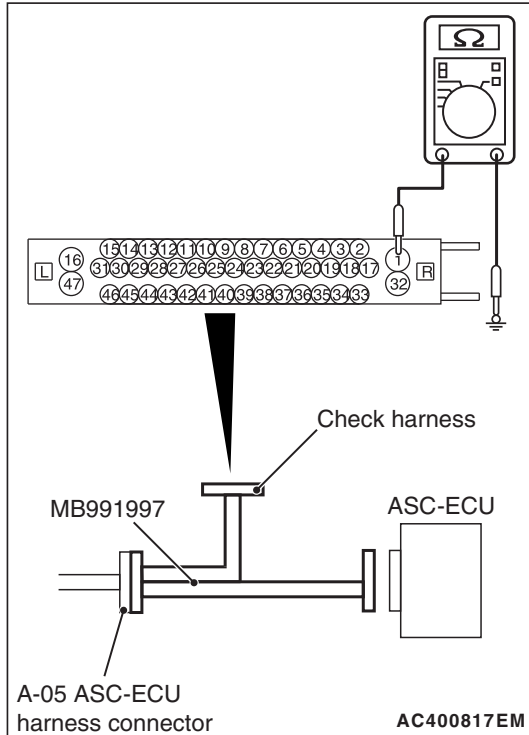
**STEP 7. Resistance measurement at A-05 ASC-ECU connector**

- (1) Disconnect the ASC-ECU connector, connect the special tool ASC check harness (MB991997) to the wiring harness-side connector, and then measure the resistance at the special tool connector side.

NOTE: Do not connect the special tool to ASC-ECU.

- (2) Disconnect the fusible link No. 26.
- (3) Measure the resistance between the terminal No. 1 and the body ground.

OK: No continuity

Q: Is the check result normal?

YES : Replace the fusible link No.26. Then go to Step 11.

NO : The short circuit may be present in the power supply circuit. Repair the wiring harness between the A-05 ASC-ECU connector terminal No.1 and the fusible link No.26, and then replace the fusible link No.26. Then go to Step 11.

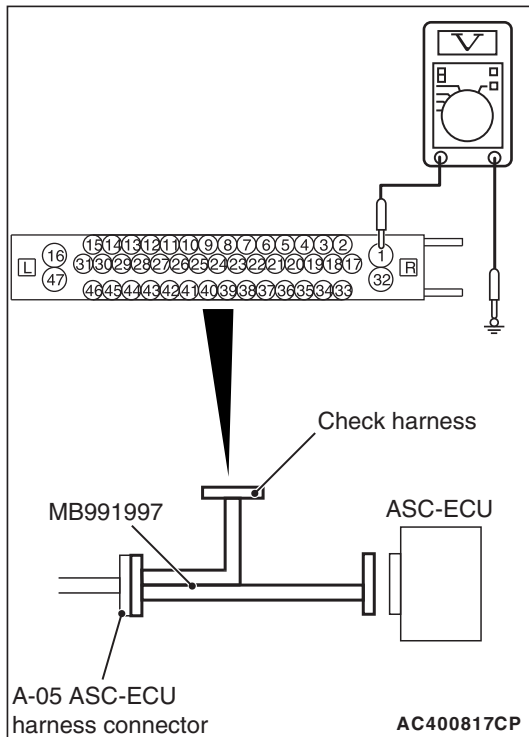
**STEP 8. Voltage measurement at the A-05 ASC-ECU connector**

- (1) Disconnect the ASC-ECU connector, connect the special tool ASC check harness (MB991997) to the wiring harness-side connector, and then measure the voltage at the special tool connector side.

NOTE: Do not connect the special tool to ASC-ECU.

- (2) Measure the voltage between the terminal No. 1 and the body ground.

OK: Battery positive voltage

Q: Is the check result normal?

YES : Go to Step 9.

NO : The open circuit may be present in the power supply circuit. Repair the wiring harness between the A-05 ASC-ECU connector terminal No.1 and the fusible link No.26. Then go to Step 11.

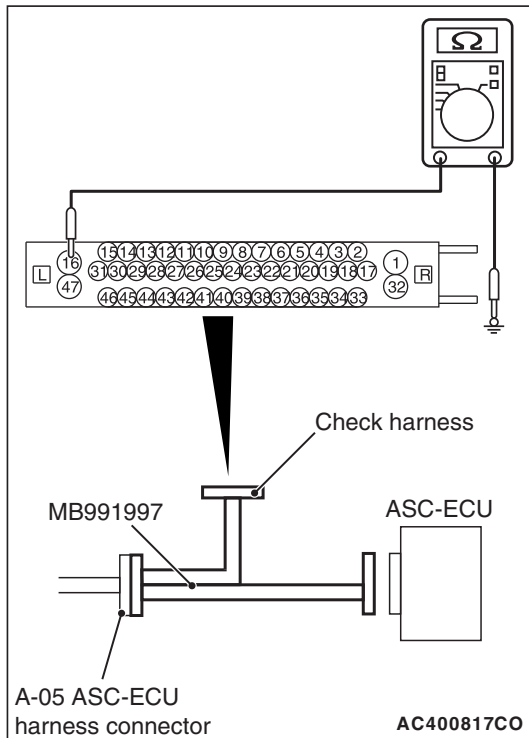

STEP 9. Resistance measurement at A-05 ASC-ECU connector

- (1) Disconnect the ASC-ECU connector, connect the special tool ASC check harness (MB991997) to the wiring harness-side connector, and then measure the resistance at the special tool connector side.

NOTE: Do not connect the special tool to ASC-ECU.

- (2) Measure the resistance between the terminal No. 16 and the body ground as well as between the terminal No. 47 and the body ground.

OK: Continuity exists (2 Ω or less)

Q: Is the check result normal?

YES : Go to Step 10.

NO : An open circuit may be present in the ground circuit. Repair the wiring harness between the A-05 ASC-ECU connector terminal No.16 and the body ground, and between the A-05 ASC-ECU connector terminal No.47 and the body ground. Then go to Step 11.

STEP 10. Check whether the DTC is reset.

- (1) Erase the DTC.
- (2) Drive the vehicle at 12mph (20 km/h) or more.

NOTE: The ABS warning light does not turn OFF in some cases unless the vehicle runs at 12mph (20 km/h) or higher.

Q: Is DTC C1073 set?

YES : Replace the hydraulic unit (incorporates in ASC-ECU).(Refer to [P.35C-298.](#)) Then go to Step 11.

NO : Intermittent malfunction. (Refer to GROUP 00 –How to Cope with Intermittent Malfunction [P.00-15.](#))

STEP 11. Check whether the DTC is reset.

- (1) Erase the DTC.
- (2) Drive the vehicle at 12mph (20 km/h) or more.

NOTE: The ABS warning light does not turn OFF in some cases unless the vehicle runs at 12mph (20 km/h) or higher.

Q: Is DTC C1073 set?

YES : Return to Step 1.

NO : This diagnosis is complete.

DTC C2116: Abnormality in power supply voltage in pump motor

Motor Power Supply Circuit

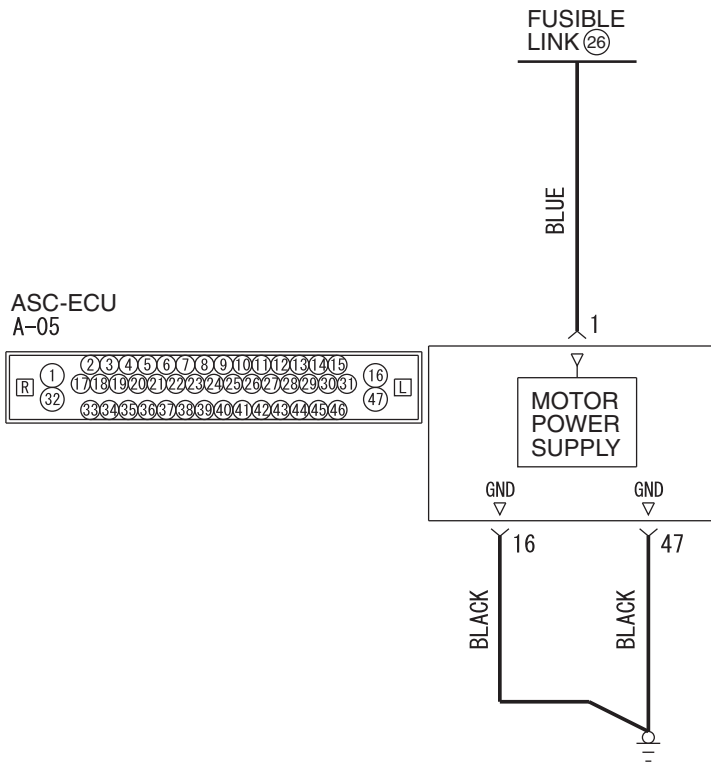

ASC-ECU
A-05

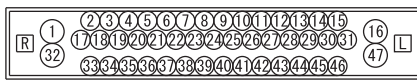

AC804602

Connector: A-05

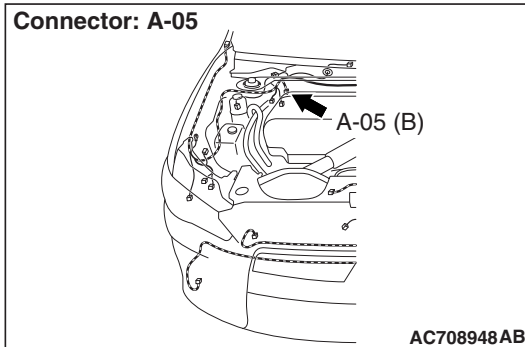

CAUTION

- If there is any problem in the CAN bus lines, an incorrect diagnostic trouble code may be set. Prior to this diagnosis, diagnose the CAN bus lines.
- Whenever the ECU is replaced, ensure that the CAN bus lines are normal.
- When the hydraulic unit (integrated with ASC-ECU) is replaced, always perform the calibration of steering wheel sensor, G and yaw rate sensor, brake fluid pressure sensor, cut valve, and inlet valve.(Refer to [P.35C-287](#), [P.35C-289](#), [P.35C-294](#), and [P.35C-295](#).)

CIRCUIT OPERATION

- ASC-ECU contains the power supply circuit (terminal No. 1) for the motor. The pump motor is energized by the pump motor switch, which is incorporated in ASC-ECU.
- The pump motor switch, which is incorporated in ASC-ECU, is always off unless the motor solenoid valve check is activated when the vehicle is started.
- ASC-ECU activates the pump motor by turning on the ECU built-in pump motor switch.

DTC SET CONDITIONS

This DTC will be set under the cases below:

- When the power supply voltage of the pump motor, which is not in operation, is abnormally low for a prolonged period
- When the power supply voltage of the pump motor, which is not in operation, is abnormally high for a prolonged period

PROBABLE CAUSES

Current trouble

- Fusible link malfunction
- Damaged wiring harness and connectors
- Abnormality in battery or generator
- ASC-ECU malfunction

Past trouble

- Perform the diagnosis with a particular emphasis on the wiring harness and connector failures in the ASC-ECU motor power supply circuit (A-05 ASC-ECU connector terminal No. 1) and in the ground circuit (A-05 ASC-ECU connector terminal No. 16 and No.47). For diagnosis procedures, refer to How to Treat Past Trouble (GROUP 00 –How to Use Troubleshooting/Inspection Service Points [P.00-16](#)).

DIAGNOSTIC PROCEDURE

Required Special Tools:

- MB991958 Scan Tool (M.U.T.-III Sub Assembly)
 - MB991824: Vehicle Communication Interface (V.C.I.)
 - MB991827 M.U.T.-III USB Cable
 - MB991910 M.U.T.-III Main Harness A
- MB991997: ASC check harness

STEP 1. Using scan tool MB991958, diagnose the CAN bus lines.

Using scan tool MB991958, diagnose the CAN bus lines.

Q: Is the check result normal?

YES : Go to Step 3.

NO : Repair the CAN bus lines (Refer to GROUP 54C – CAN Bus Diagnosis table [P.54C-15](#)). On completion, go to Step 2.

STEP 2. DTC recheck after repairing the CAN bus line**Q: Is DTC C2116 set?****YES** : Go to Step 3.**NO** : This diagnosis is complete.

STEP 3. Battery checkRefer to GROUP 54A –Battery Test [P.54A-9](#).**Q: Is the battery in good condition?****YES** : Go to Step 4.**NO** : Replace the battery. Then go to Step 11.

STEP 4. Charging system checkRefer to GROUP 16 –Output Current Test [P.16-8](#).**Q: Is the charging system in good condition?****YES** : Go to Step 5.**NO** : Repair or replace the charging system component(s).

STEP 5. Connector check: A-05 ASC-ECU connector**Q: Is the check result normal?****YES** : Go to Step 6.**NO** : Repair the defective connector. Then go to Step 11.

STEP 6. Fusible link check: Check the fusible link No.26.

Visually check for open circuit in the fusible link No.26.

Q: Is the check result normal?**YES** : Go to Step 8.**NO** : Go to Step 7.

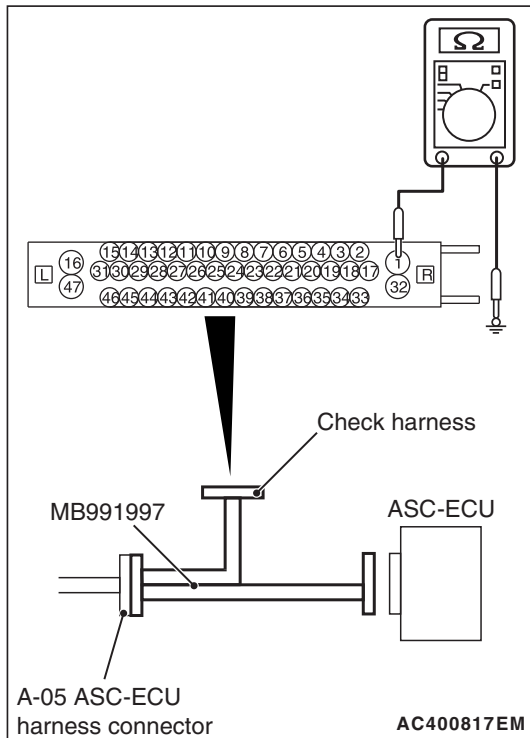

STEP 7. Resistance measurement at A-05 ASC-ECU connector

- (1) Disconnect the ASC-ECU connector, connect the special tool ASC check harness (MB991997) to the wiring harness-side connector, and then measure the resistance at the special tool connector side.

NOTE: Do not connect the special tool to ASC-ECU.

- (2) Disconnect the fusible link No. 26.
- (3) Resistance between the terminal No. 1 and the body ground.

OK: No continuity

Q: Is the check result normal?

YES : Replace the fusible link No.26. Then go to Step 11.

NO : The short circuit may be present in the power supply circuit. Repair the wiring harness between the A-05 ASC-ECU connector terminal No.1 and the fusible link No.26, and then replace the fusible link No.26. Then go to Step 11.

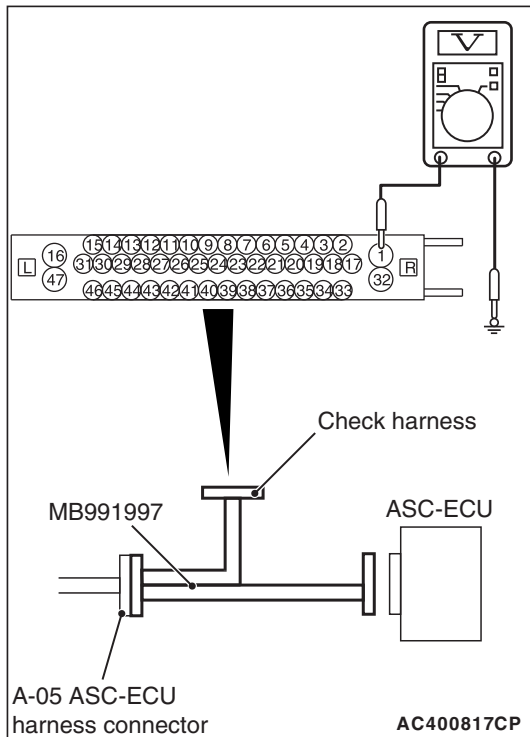

STEP 8. Voltage measurement at the A-05 ASC-ECU connector

- (1) Disconnect the connector, connect the special tool ASC check harness (MB991997) to the wiring harness-side connector, and measure the voltage at the special tool connector side.

NOTE: Do not connect the special tool to ASC-ECU.

- (2) Measure the voltage between the terminal No. 1 and the body ground.

OK: Battery positive voltage

Q: Is the check result normal?

YES : Go to Step 9.

NO : The open circuit may be present in the power supply circuit. Repair the wiring harness between the A-05 ASC-ECU connector terminal No.1 and the fusible link No.26. Then go to Step 11.

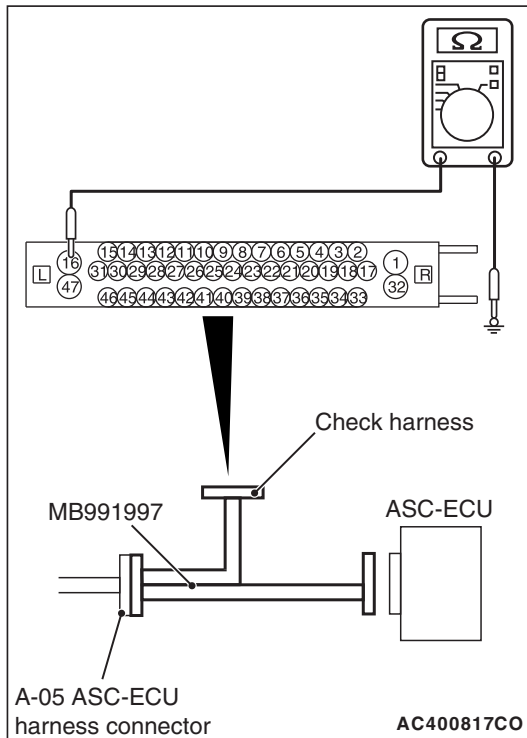
**STEP 9. Resistance measurement at A-05 ASC-ECU connector**

- (1) Disconnect the connector, connect the special tool ASC check harness (MB991997) to the wiring harness-side connector, and then measure the voltage at the special tool connector side.

NOTE: Do not connect the special tool to ASC-ECU.

- (2) Measure the resistance between the terminal No. 16 and the body ground as well as between the terminal No. 47 and the body ground.

OK: Continuity exists (2 Ω or less)

Q: Is the check result normal?

YES : Go to Step 10.

NO : An open circuit may be present in the ground circuit. Repair the wiring harness between the A-05 ASC-ECU connector terminal No.16 and the body ground, and between the A-05 ASC-ECU connector terminal No.47 and the body ground. Then go to Step 11.

STEP 10. Check whether the DTC is reset.

- (1) Erase the DTC.
- (2) Drive the vehicle at 12mph (20 km/h) or more.

NOTE: The ABS warning light does not turn OFF in some cases unless the vehicle runs at 12mph (20 km/h) or higher.

Q: Is DTC C2116 set?

YES : Replace the hydraulic unit (incorporates in ASC-ECU).(Refer to [P.35C-298.](#)) Then go to Step 11.

NO : Intermittent malfunction. (Refer to GROUP 00 –How to Cope with Intermittent Malfunction [P.00-15.](#))

STEP 11. Check whether the DTC is reset.

- (1) Erase the DTC.
- (2) Drive the vehicle at 12mph (20 km/h) or more.

NOTE: The ABS warning light does not turn OFF in some cases unless the vehicle runs at 12mph (20 km/h) or higher.

Q: Is DTC C2116 set?

YES : Return to Step 1.

NO : This diagnosis is complete.

DTC C121D: Abnormality in brake fluid pressure sensor circuit

⚠ CAUTION

- If there is any problem in the CAN bus lines, an incorrect diagnostic trouble code may be set. Prior to this diagnosis, diagnose the CAN bus lines.
- Whenever the ECU is replaced, ensure that the CAN bus lines are normal.
- When the hydraulic unit (integrated with ASC-ECU) is replaced, always perform the calibration of steering wheel sensor, G and yaw rate sensor, brake fluid pressure sensor, cut valve, and inlet valve.(Refer to [P.35C-287](#), [P.35C-289](#), [P.35C-294](#), and [P.35C-295](#).)

CIRCUIT OPERATION

The pressure sensor is incorporated in the hydraulic unit. When the brake pedal is depressed, the pressure sensor detects the brake pressure applied from the master cylinder, converts this pressure into the voltage signal, and then outputs the signal.

DTC SET CONDITIONS

If the pressure sensor output signal is outside the standard value range, this diagnostic trouble code is set.

PROBABLE CAUSES

- Incorrect brake pedal height
- Incorrect adjustment of stoplight switch
- Master cylinder malfunction
- Brake booster malfunction
- ASC-ECU malfunction

DIAGNOSIS**Required Special Tools:**

- MB991958 Scan Tool (M.U.T.-III Sub Assembly)
 - MB991824: Vehicle Communication Interface (V.C.I.)
 - MB991827 M.U.T.-III USB Cable
 - MB991910 M.U.T.-III Main Harness A
- MB991997: ASC check harness

STEP 1. Using scan tool MB991958, diagnose the CAN bus lines.

Using scan tool MB991958, diagnose the CAN bus lines.

Q: Is the check result normal?

YES : Go to Step 3.

NO : Repair the CAN bus lines. (Refer to GROUP 54C – Troubleshooting [P.54C-15](#).) After repairing the CAN bus line, go to Step 2.

STEP 2. DTC recheck after repairing the CAN bus line**Q: Is DTC C121D set?****YES** : Go to Step 3.**NO** : The procedure is complete.

STEP 3. Brake pedal checkRefer to GROUP 35A –On-vehicle Service [P.35A-12](#).**Q: Is the check result normal?****YES** : Go to Step 4.**NO** : Adjust the brake pedal height. (Refer to GROUP 35A – On-vehicle Service [P.35A-12](#).) Then go to Step 7.

STEP 4. Check of stoplight switch installation statusRefer to GROUP 35A –On-vehicle Service [P.35A-12](#).**Q: Is the check result normal?****YES** : Go to Step 5.**NO** : Install the stoplight switch correctly. (Refer to GROUP 35A –On-vehicle Service [P.35A-12](#).) Then go to Step 7.

STEP 5. Brake booster checkRefer to GROUP 35A –On-vehicle Service [P.35A-15](#).**Q: Is the check result normal?****YES** : Go to Step 6.**NO** : Replace the brake booster. (Refer to GROUP 35A – Master Cylinder Assembly and Brake Booster [P.35A-26](#).) Then go to Step 7.

STEP 6. Check whether the DTC is reset.**Q: Is DTC C121D set?****YES** : Replace the hydraulic unit (incorporates in ASC-ECU).(Refer to [P.35C-298](#).) Then go to Step 7.**NO** : Intermittent malfunction. (Refer to GROUP 00 –How to Cope with Intermittent Malfunction [P.00-15](#).)

STEP 7. Check whether the DTC is reset.**Q: Is DTC C121D set?****YES** : Return to Step 1.**NO** : The procedure is complete.

DTC C121E: Abnormality in brake fluid pressure sensor output signal

⚠ CAUTION

- If there is any problem in the CAN bus lines, an incorrect diagnostic trouble code may be set. Prior to this diagnosis, diagnose the CAN bus lines.
- Whenever the ECU is replaced, ensure that the CAN bus lines are normal.
- When the hydraulic unit (integrated with ASC-ECU) is replaced, always perform the calibration of steering wheel sensor, G and yaw rate sensor, brake fluid pressure sensor, cut valve, and inlet valve.(Refer to [P.35C-287](#), [P.35C-289](#), [P.35C-294](#), and [P.35C-295](#).)

CIRCUIT OPERATION

The pressure sensor is incorporated in the hydraulic unit. When the brake pedal is depressed, the pressure sensor detects the brake pressure applied from the master cylinder, converts this pressure into the voltage signal, and then outputs the signal.

DTC SET CONDITIONS

This diagnostic trouble codes will be set under the cases below:

- The pressure sensor offset is outside the specified range. (Pressure is generated at all times)
- The estimated pressure sensor temperature is not normal.

PROBABLE CAUSES

- Incorrect adjustment of brake pedal height
- Master cylinder malfunction
- Brake booster malfunction
- Incorrect installation position of stoplight switch
- Malfunction of the stoplight switch
- Brake drag
- Malfunction of the ASC-ECU

DIAGNOSIS

Required Special Tools:

- MB991958 Scan Tool (M.U.T.-III Sub Assembly)
 - MB991824: Vehicle Communication Interface (V.C.I.)
 - MB991827 M.U.T.-III USB Cable
 - MB991910 M.U.T.-III Main Harness A
- MB991997: ASC check harness

STEP 1. Using scan tool MB991958, diagnose the CAN bus lines.

Using scan tool MB991958, diagnose the CAN bus lines.

Q: Is the check result normal?

YES : Go to Step 3.

NO : Repair the CAN bus lines. (Refer to GROUP 54C – Troubleshooting [P.54C-15](#).) After repairing the CAN bus line, go to Step 2.

STEP 2. DTC recheck after repairing the CAN bus line**Q: Is DTC C121E set?**

YES : Go to Step 3.

NO : The procedure is complete.

STEP 3. Brake pedal check

Refer to GROUP 35A –On-vehicle Service [P.35A-12](#).

Q: Is the check result normal?

YES : Go to Step 4.

NO : Adjust the brake pedal height. (Refer to GROUP 35A – On-vehicle Service [P.35A-12](#).) Then go to Step 9.

STEP 4. Check for stoplight switch installation

Refer to GROUP 35A –On-vehicle Service [P.35A-12](#).

Q: Is the check result normal?

YES : Go to Step 5.

NO : Install the stoplight switch correctly. (Refer to GROUP 35A –On-vehicle Service [P.35A-12](#).) Then go to Step 9.

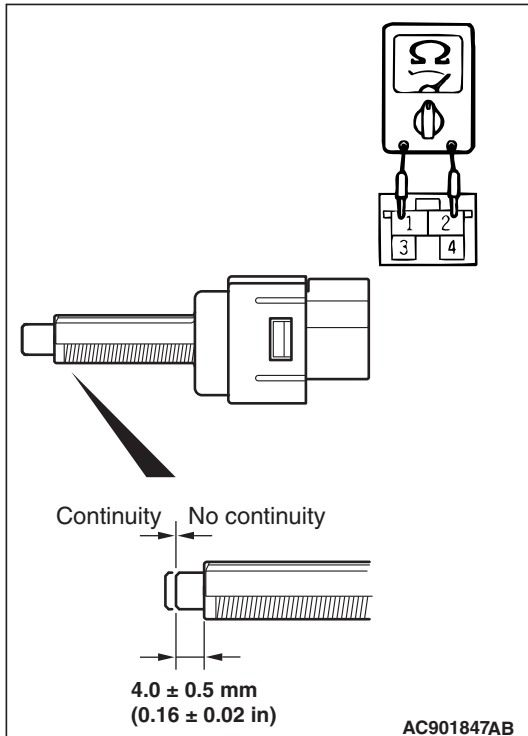

STEP 5. Stoplight switch continuity check

- (1) Remove the stoplight switch. (Refer to GROUP 35A –Brake Pedal [P.35A-24.](#))
- (2) Connect the circuit tester (Ω range) to the stoplight switch connector terminal Nos. 1 and 2.
- (3) When continuity does not exist with the plunger pressed from the outer case end face by the dimension shown in the figure, and when continuity exists with the plunger released, the switch is in good condition.

Q: Is the check result normal?

YES : Go to Step 6.

NO : Replace the stoplight switch. (Refer to GROUP 35A – Brake Pedal [P.35A-24.](#)) Then go to Step 9.

STEP 6. Brake drag check

Check the brake drag force. (Refer to GROUP 35A –On-vehicle Service [P.35A-23.](#))

Q: Is the check result normal?

YES : Go to Step 7.

NO : Adjust the brake drag, and then go to Step 9.

STEP 7. Brake booster check

Refer to GROUP 35A –On-vehicle Service [P.35A-15.](#)

Q: Is the check result normal?

YES : Go to Step 8.

NO : Replace the brake booster. (Refer to GROUP 35A – Master Cylinder Assembly and Brake Booster [P.35A-26.](#)) Then go to Step 9.

STEP 8. Check whether the DTC is reset.

Q: Is DTC C121E set?

YES : Replace the hydraulic unit (incorporates in ASC-ECU).(Refer to [P.35C-298.](#)) Then go to Step 9.

NO : Intermittent malfunction. (Refer to GROUP 00 –How to Cope with Intermittent Malfunction [P.00-15.](#))

STEP 9. Check whether the DTC is reset.**Q: Is DTC C121E set?****YES :** Return to Step 1.**NO :** The procedure is complete.

DTC C2000: Abnormality in wheel fluid pressure sensor circuit

⚠ CAUTION

- If there is any problem in the CAN bus lines, an incorrect diagnostic trouble code may be set. Prior to this diagnosis, diagnose the CAN bus lines.
- Whenever the ECU is replaced, ensure that the CAN bus lines are normal.
- When the hydraulic unit (integrated with ASC-ECU) is replaced, always perform the calibration of steering wheel sensor, G and yaw rate sensor, brake fluid pressure sensor, cut valve, and inlet valve.(Refer to [P.35C-287](#), [P.35C-289](#), [P.35C-294](#), and [P.35C-295](#).)

CIRCUIT OPERATION

The wheel cylinder pressure sensor is integrated into the hydraulic unit. It converts the signal of brake fluid pressure in wheel cylinder of each wheel to the voltage value, then outputs the value to ASC-ECU.

DTC SET CONDITIONS

This diagnostic trouble code is set when the voltage value, which was converted from the signal of brake fluid pressure in wheel cylinder of each wheel and sent by the wheel cylinder pressure sensor to ASC-ECU, is outside the standard range.

PROBABLE CAUSES

- Damaged wiring harness and connectors
- Malfunction of hydraulic unit (with built-in wheel cylinder pressure sensor)

DIAGNOSIS**Required Special Tools:**

- MB991958 Scan Tool (M.U.T.-III Sub Assembly)
 - MB991824: Vehicle Communication Interface (V.C.I.)
 - MB991827 M.U.T.-III USB Cable
 - MB991910 M.U.T.-III Main Harness A
- MB991997: ASC check harness

STEP 1. Using scan tool MB991958, diagnose the CAN bus lines.

Using scan tool MB991958, diagnose the CAN bus lines.

Q: Is the check result normal?

YES : Go to Step 3.

NO : Repair the CAN bus lines. (Refer to GROUP 54C – Troubleshooting [P.54C-15.](#)) After repairing the CAN bus line, go to Step 2.

STEP 2. DTC recheck after repairing the CAN bus line

Q: Is DTC C2000 set?

YES : Go to Step 3.

NO : The procedure is complete.

STEP 3. Check whether the DTC is reset.

Q: Is DTC C2000 set?

YES : Replace the hydraulic unit (incorporates in ASC-ECU).(Refer to [P.35C-298.](#)) Then go to Step 4.

NO : Intermittent malfunction. (Refer to GROUP 00 –How to Cope with Intermittent Malfunction [P.00-15.](#))

STEP 4. Check whether the DTC is reset.

Q: Is DTC C2000 set?

YES : Return to Step 1.

NO : The procedure is complete.

DTC C2001: Abnormality in wheel fluid pressure sensor output signal

⚠ CAUTION

- If there is any problem in the CAN bus lines, an incorrect diagnostic trouble code may be set. Prior to this diagnosis, diagnose the CAN bus lines.
- Whenever the ECU is replaced, ensure that the CAN bus lines are normal.
- When the hydraulic unit (integrated with ASC-ECU) is replaced, always perform the calibration of steering wheel sensor, G and yaw rate sensor, brake fluid pressure sensor, cut valve, and inlet valve.(Refer to [P.35C-287](#), [P.35C-289](#), [P.35C-294](#), and [P.35C-295.](#))

CIRCUIT OPERATION

- The wheel cylinder pressure sensor is integrated into the hydraulic unit. It converts the signal of brake fluid pressure in wheel cylinder of each wheel to the voltage value, then outputs the value to ASC-ECU.
- The wheel cylinder pressure sensor contains the following two signal output sections: Fluid pressure signal output section and fluid pressure and temperature signal output section.

DTC SET CONDITIONS

This diagnostic trouble codes will be set under the cases below:

- The pressure sensor offset is outside the specified range. (Pressure is generated at all times)
- The estimated pressure sensor temperature is not normal.

PROBABLE CAUSES

- Damaged wiring harness and connectors
- Incorrect adjustment of brake pedal height
- Master cylinder malfunction
- Brake booster malfunction
- Incorrect installation position of stoplight switch
- Malfunction of the stoplight switch
- Brake drag
- Malfunction of the ASC-ECU

DIAGNOSIS**Required Special Tools:**

- MB991958 Scan Tool (M.U.T.-III Sub Assembly)
 - MB991824: Vehicle Communication Interface (V.C.I.)
 - MB991827 M.U.T.-III USB Cable
 - MB991910 M.U.T.-III Main Harness A
- MB991997: ASC check harness

STEP 1. Using scan tool MB991958, diagnose the CAN bus lines.

Using scan tool MB991958, diagnose the CAN bus lines.

Q: Is the check result normal?

YES : Go to Step 3.

NO : Repair the CAN bus lines. (Refer to GROUP 54C – Troubleshooting [P.54C-15.](#)) After repairing the CAN bus line, go to Step 2.

STEP 2. DTC recheck after repairing the CAN bus line**Q: Is DTC C2001 set?**

YES : Go to Step 3.

NO : This diagnosis is complete.

STEP 3. Check for diagnostic trouble codes of other systems

Check if the diagnostic trouble code No. C121E is set in ASC-ECU.

Q: Is the check result normal?

YES : Go to Step 4.

NO : Carry out the diagnosis for the diagnostic trouble code No. C121E. (Refer to [P.35C-139.](#))

STEP 4. Scan tool service data

Check the following service data. (Refer to [P.35C-276.](#))

- Item 129: FL wheel cylinder pressure
- Item 130: FR wheel cylinder pressure
- Item 131: RL wheel cylinder pressure
- Item 132: RR wheel cylinder pressure

Q: Is the check result normal?

YES : Go to Step 5.

NO : Go to Step 10.

STEP 5. Brake drag check

Check the brake drag force. (Refer to GROUP 35A –On-vehicle Service [P.35A-23.](#))

Q: Is the check result normal?

YES : Go to Step 6.

NO : Adjust the brake drag, and then go to Step 11.

STEP 6. Brake pedal check

Refer to GROUP 35A –On-vehicle Service [P.35A-12.](#)

Q: Is the check result normal?

YES : Go to Step 7.

NO : Adjust the brake pedal height to the standard value.
(Refer to GROUP 35A –On-vehicle Service [P.35A-12.](#)) Then go to Step 11.

STEP 7. Check for stoplight switch installation

Refer to GROUP 35A –On-vehicle Service [P.35A-12.](#)

Q: Is the check result normal?

YES : Go to Step 8.

NO : Install the stoplight switch correctly. (Refer to GROUP 35A –On-vehicle Service [P.35A-12.](#)) Then go to Step 11.

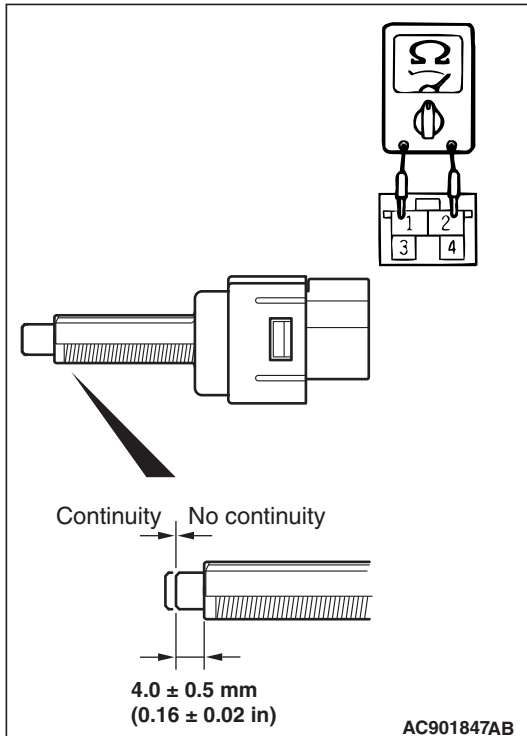
**STEP 8. Stoplight switch continuity check**

- (1) Remove the stoplight switch. (Refer to GROUP 35A –Brake Pedal [P.35A-24.](#))
- (2) Connect the circuit tester (Ω range) to the stoplight switch connector terminal Nos. 1 and 2.
- (3) When continuity does not exist with the plunger pressed from the outer case end face by the dimension shown in the figure, and when continuity exists with the plunger released, the switch is in good condition.

Q: Is the check result normal?**YES** : Go to Step 9.**NO** : Replace the stoplight switch. (Refer to GROUP 35A – Brake Pedal [P.35A-24.](#)) Then go to Step 11.**STEP 9. Brake booster check**Refer to GROUP 35A –On-vehicle Service [P.35A-15.](#)**Q: Is the check result normal?****YES** : Go to Step 10.**NO** : Replace the brake booster. (Refer to GROUP 35A – Master Cylinder Assembly and Brake Booster [P.35A-26.](#)) Then go to Step 11.**STEP 10. Check whether the DTC is reset.****Q: Is DTC C2001 set?****YES** : Replace the hydraulic unit (incorporates in ASC-ECU).(Refer to [P.35C-298.](#)) Then go to Step 11.**NO** : Intermittent malfunction. (Refer to GROUP 00 –How to Cope with Intermittent Malfunction [P.00-15.](#))**STEP 11. Check whether the DTC is reset.****Q: Is DTC C2001 set?****YES** : Return to Step 1.**NO** : The procedure is complete.

DTC C1000: Abnormality in stoplight switch circuit

Stoplight Circuit

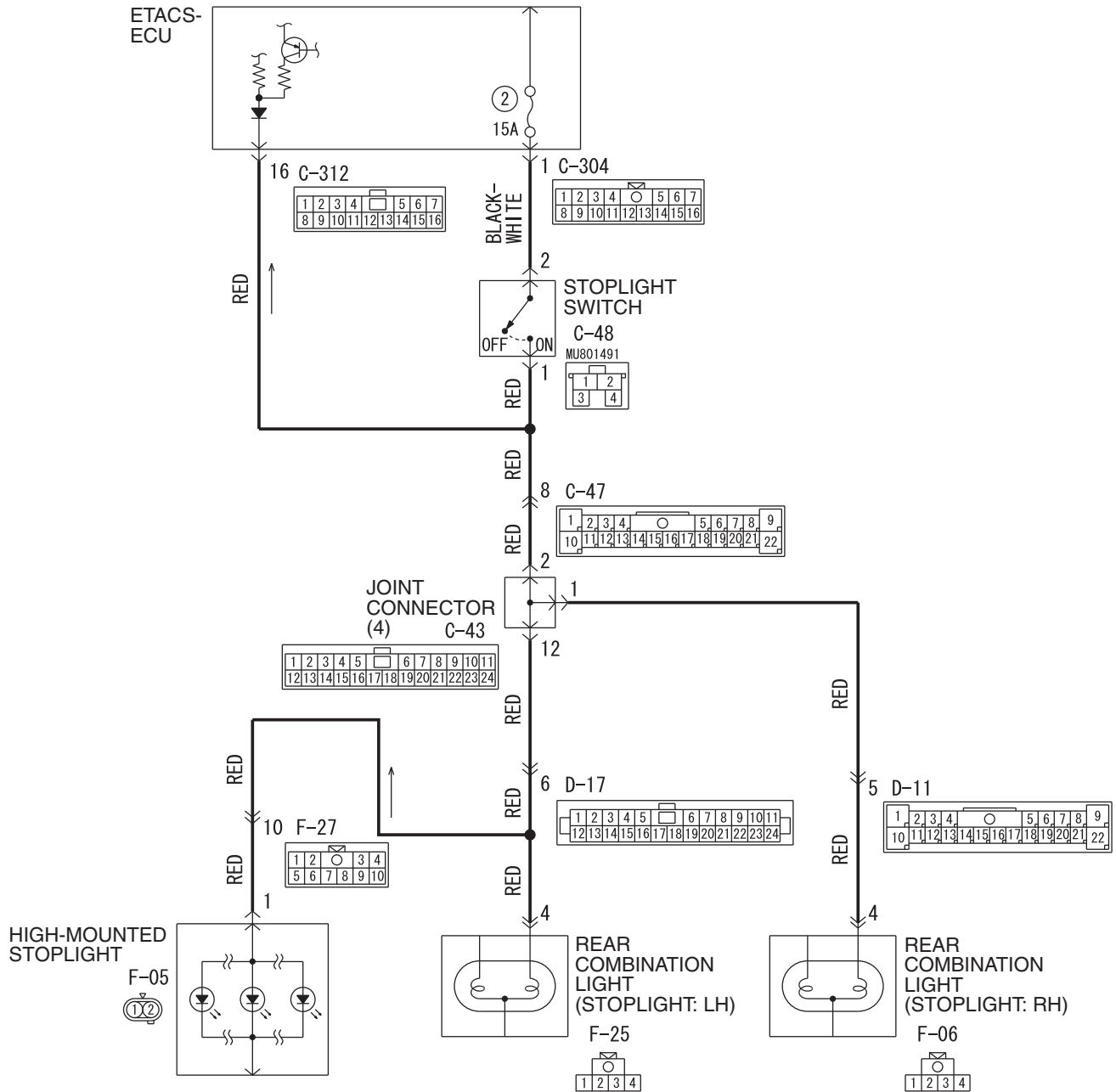

AC804604

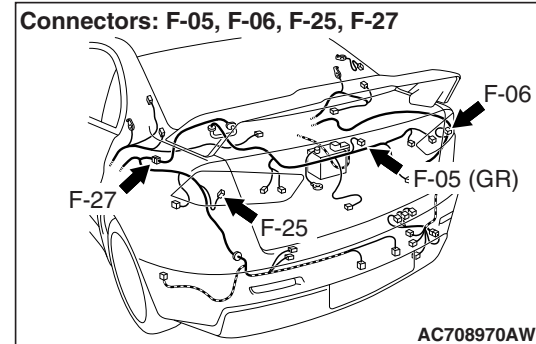
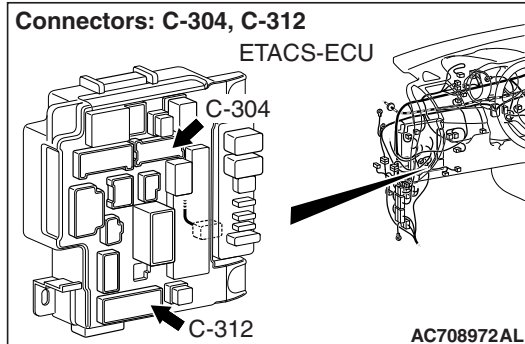
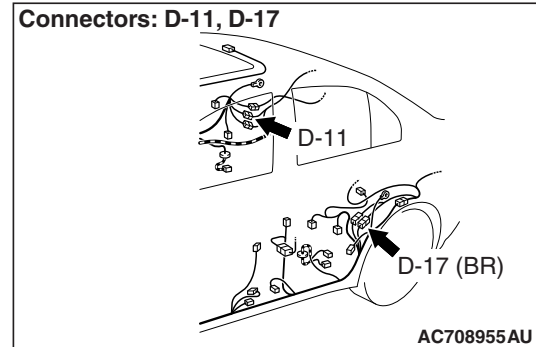
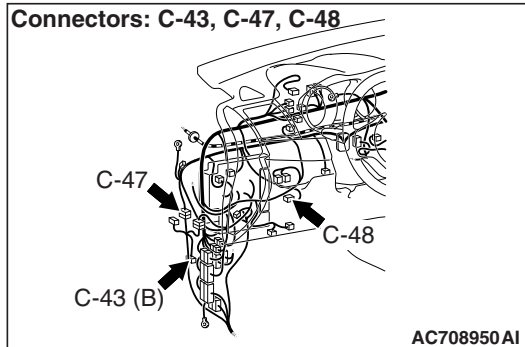

⚠ CAUTION

- If there is any problem in the CAN bus lines, an incorrect diagnostic trouble code may be set. Prior to this diagnosis, diagnose the CAN bus lines.
- Whenever the ECU is replaced, ensure that the CAN bus lines are normal.
- When the hydraulic unit (integrated with ASC-ECU) is replaced, always perform the calibration of steering wheel sensor, G and yaw rate sensor, brake fluid pressure sensor, cut valve, and inlet valve. (Refer to [P.35C-287](#), [P.35C-289](#), [P.35C-294](#), and [P.35C-295](#).)

CIRCUIT OPERATION

ETACS-ECU sends the ON signal generated when the brake pedal is depressed and OFF signal generated when the pedal is released to ASC-ECU via CAN bus lines.

DTC SET CONDITIONS

This diagnostic trouble code is set in the following case.

- The vehicle has run for a long time with the stoplight switch turned ON.
- The OFF status of the stoplight switch does not match the vehicle behavior.

PROBABLE CAUSES

- Improper adjustment of stoplight switch installation position
- Malfunction of the stoplight switch
- Malfunction of the stoplight
- Damaged wiring harness and connectors
- Malfunction of ETACS-ECU
- Malfunction of the ASC-ECU

DIAGNOSIS

Required Special Tools:

- MB991958 Scan Tool (M.U.T.-III Sub Assembly)
 - MB991824: Vehicle Communication Interface (V.C.I.)
 - MB991827 M.U.T.-III USB Cable
 - MB991910 M.U.T.-III Main Harness A

STEP 1. Using scan tool MB991958, diagnose the CAN bus lines.

Using scan tool MB991958, diagnose the CAN bus lines.

Q: Is the check result normal?

YES : Go to Step 3.

NO : Repair the CAN bus lines. (Refer to GROUP 54C – CAN Bus Diagnosis table [P.54C-15.](#)) On completion, go to Step 2.

STEP 2. DTC recheck after repairing the CAN bus line

Q: Is DTC C1000 set?

YES : Go to Step 3.

NO : This diagnosis is complete.

STEP 3. Battery check

Refer to GROUP 54A –Battery Test [P.54A-9.](#)

Q: Is the battery in good condition?

YES : Go to Step 4.

NO : Charge or replace the battery, and the go to Step 16.

STEP 4. Stoplight operation check

Check the stoplight operation when the brake pedal is depressed. Check that all the stoplight illuminates when the brake pedal is depressed and that it goes out when the brake pedal is released.

OK:

When the brake pedal is released: OFF

When the brake pedal is depressed: Illuminates

Q: Is the check result normal?

YES : Go to Step 18.

NO : Go to Step 5.

STEP 5. Check for stoplight switch installation

Refer to GROUP 35A –On-vehicle Service [P.35A-12.](#)

Q: Is the check result normal?

YES : Go to Step 6.

NO : Install the stoplight switch correctly. (Refer to GROUP 35A –On-vehicle Service [P.35A-12.](#)) Then, go to Step 23.

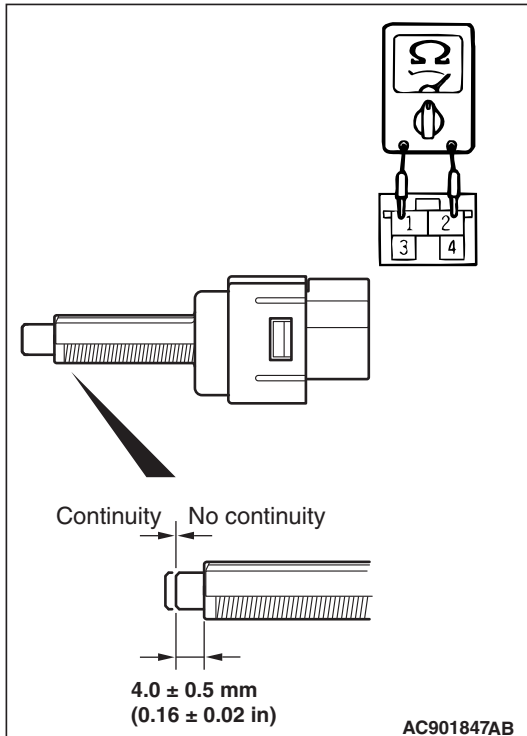
**STEP 6. Stoplight switch continuity check**

- (1) Remove the stoplight switch. (Refer to GROUP 35A –Brake Pedal [P.35A-24.](#))
- (2) Connect the circuit tester (Ω range) to the stoplight switch connector terminal Nos. 1 and 2.
- (3) When continuity does not exist with the plunger pressed from the outer case end face by the dimension shown in the figure, and when continuity exists with the plunger released, the switch is in good condition.

Q: Is the check result normal?**YES** : Go to Step 7.**NO** : Replace the stoplight switch. (Refer to GROUP 35A – Brake Pedal [P.35A-24.](#)) Then go to Step 23.**STEP 7. ETACS-ECU fuse No.2 check****Q: Is the check result normal?****YES** : Go to Step 12.**NO** : Go to Step 8.

STEP 8. Connector check: C-43 joint connector, C-47 intermediate connector, C-48 stoplight switch connector, C-304 ETACS-ECU connector, C-309 ETACS-ECU connector, C-312 ETACS-ECU connector, D-11 intermediate connector, D-17 intermediate connector, F-05 high-mounted stoplight, F-06 rear combination light (stoplight: RH), F-25 rear combination light (stoplight: LH), F-27 intermediate connector

Q: Is the check result normal?**YES** : Go to Step 9.**NO** : Repair the defective connector. Then, replace fuse No. 2. Then go to Step 23.

STEP 9. Resistance measurement at C-48 stoplight switch connector

- (1) Disconnect C-48 stoplight switch connector, and measure at the wiring harness side.
- (2) Disconnect C-312 ETACS-ECU connector and C-43 joint connector.
- (3) Measure the resistance between the terminal No.1 and the body ground.

OK: No continuity

Q: Is the check result normal?

YES : Go to Step 10.

NO : A short circuit may be present in the wiring harness between C-43 joint connector terminal No.2 and C-48 stoplight switch connector terminal No.1 or between C-312 ETACS-ECU connector terminal No.16 and C-48 stoplight switch connector terminal No.1. Repair the wiring harness if necessary, and then replace fuse No.2. Then go to Step 23.

STEP 10. Resistance measurement at C-48 stoplight switch connector

- (1) Disconnect C-48 stoplight switch connector, and measure at the wiring harness side.
- (2) Disconnect C-304 ETACS-ECU connector.
- (3) Measure the resistance between the terminal No.2 and the body ground.

OK: No continuity

Q: Is the check result normal?

YES : Go to Step 11.

NO : A short circuit may be present in the wiring harness between C-304 ETACS-ECU connector terminal No.1 and C-48 stoplight switch connector terminal No.2. Repair the wiring harness if necessary, and then replace fuse No.2. Then go to Step 23.

STEP 11. Resistance measurement at C-43 joint connector

- (1) Disconnect C-43 joint connector, and measure at the wiring harness side.
- (2) Disconnect F-06 rear combination light (stoplight: RH) connector, F-25 rear combination light (stoplight: LH) connector, F-05 highmounted stoplight connector.
- (3) Measure the resistance between the terminal No.2 and the body ground.

OK: No continuity

Q: Is the check result normal?

YES : Replace fuse No.2. Then go to Step 23.

NO : A short circuit may be present in the wiring harness between C-43 joint connector terminal No.2 and F-06 rear combination light (stoplight: RH) connector terminal No.4 or between C-43 joint connector terminal No.2 and F-25 rear combination light (stoplight: LH) connector terminal No.4 or between C-43 joint connector terminal No.2 and F-05 highmounted stoplight connector terminal No.1. Repair the wiring harness if necessary, and then replace fuse No.2. Then go to Step 23 .

STEP 12. Connector check: C-304 ETACS-ECU connector**Q: Is the check result normal?**

YES : Go to Step 13.

NO : Repair the damaged connector.

STEP 13. Measure the voltage at the C-304 ETACS-ECU connector.** CAUTION**

Measure while the brake pedal is not depressed.

Measure the voltage between terminal No. 1 and the body ground by backprobing.

OK: Battery positive voltage

Q: Is the check result normal?

YES : Go to Step 14.

NO : Replace the ETACS-ECU (Refer to GROUP 54A – ETACS-ECU [P.54A-742](#)). Then go to Step 23.

STEP 14. Connector check: C-24 Stoplight switch connector**Q: Is the check result normal?**

YES : Go to Step 15.

NO : Repair the damaged connector.

STEP 15. Measure the voltage at C-48 stoplight switch connector.

- (1) Disconnect C-48 stoplight switch connector, and measure the voltage at harness connector side.
- (2) Measure the voltage between the terminal No.2 and the body ground.

OK: Battery positive voltage

Q: Is the check result normal?

YES : Go to Step 16.

NO : An open circuit may be present in the wiring harness between C-304 ETACS-ECU connector terminal No. 1 and C-48 stoplight switch connector terminal No. 2. Repair the wiring harness.

STEP 16. Connector check: C-43 joint connector

Q: Is the check result normal?

YES : Go to Step 17.

NO : Repair the damaged connector.

STEP 17. Voltage measurement at C-43 joint connector

⚠ CAUTION

Measure while the brake pedal is depressed.

- (1) Disconnect the connector, and measure at the wiring harness side.
- (2) Measure the voltage between the terminal No.2 and the body ground.

OK: Battery positive voltage

Q: Is the check result normal?

YES : Go to Step 18.

NO : An open circuit may be present in the wiring harness between C-43 joint connector terminal No.2 and C-48 stoplight switch connector terminal No.1. Repair the wiring harness.

STEP 18. Connector check: C-312 ETACS-ECU connector

Q: Is the check result normal?

YES : Go to Step 19.

NO : Repair the damaged connector.

STEP 19. Measure the voltage at the C-312 ETACS-ECU connector.

- (1) Measure by backprobing without disconnecting the connector.
- (2) Measure the voltage between the terminal No.16 and the body ground.

OK:

When the brake pedal is released: 0 V - 5V (pulse)
When the brake pedal is depressed: Approximately battery positive voltage

Q: Is the check result normal?

YES : Go to Step 22.

NO : Go to Step 20.

STEP 20. Check the wiring harness between C-312 ETACS-ECU connector terminal No.16 and C-48 stoplight switch connector terminal No.1

- Check the signal line for open circuit.

Q: Is the check result normal?

YES : Go to Step 21.

NO : Replace the wiring harness.

STEP 21. Diagnostic trouble code recheck**Q: Is diagnostic trouble code No.C1000 set?**

YES : Replace the hydraulic unit (ASC-ECU) (Refer to [P.35C-298](#)). Then go to Step 23.

NO : Intermittent malfunction (Refer to GROUP 00 –How to Cope with Intermittent Malfunction [P.00-15](#).)

STEP 22. Check whether the DTC is reset.**Q: Is DTC 1000 set?**

YES : Replace the hydraulic unit (incorporates in ASC-ECU).(Refer to [P.35C-298](#).) Then go to Step 23.

NO : Intermittent malfunction. (Refer to GROUP 00 –How to Cope with Intermittent Malfunction [P.00-15](#).)

STEP 23. Check whether the DTC is reset.**Q: Is DTC 1000 set?**

YES : Return to Step 1.

NO : The procedure is complete.

DTC C123B: Prolonged operation of ASC

⚠ CAUTION

- If there is any problem in the CAN bus lines, an incorrect diagnostic trouble code may be set. Prior to this diagnosis, diagnose the CAN bus lines.
- Whenever the ECU is replaced, ensure that the CAN bus lines are normal.
- When the steering wheel sensor is replaced or re-installed, always perform the calibration to make ASC-ECU learn the neutral point. (Refer to [P.35C-289](#).)
- Do not drop the G and yaw rate sensor or subject it to a shock.
- When the G and yaw rate sensor is replaced, always perform the calibration to make ASC-ECU learn the neutral point. (Refer to [P.35C-287](#).)
- When the hydraulic unit (integrated with ASC-ECU) is replaced, always perform the calibration of steering wheel sensor, G and yaw rate sensor, brake fluid pressure sensor, cut valve, and inlet valve. (Refer to [P.35C-287](#), [P.35C-289](#), [P.35C-294](#), and [P.35C-295](#).)

CIRCUIT OPERATION

ASC-ECU controls ASC by calculating the data sent from the wheel speed sensor, steering wheel sensor, and G and yaw rate sensor.

DTC SET CONDITIONS

This diagnostic trouble code is set when ASC control is operated for a prolonged period.

NOTE: This diagnostic trouble code may be set when the vehicle runs on a slippery or rough road, or when the vehicle performs a steady state cornering.

PROBABLE CAUSES

- Steering wheel sensor malfunction
- G and yaw rate sensor malfunction
- Improper installation of steering wheel sensor or G and yaw rate sensor
- ASC-ECU malfunction
- Different steering wheel
- Wheel alignment not performed

DIAGNOSIS**Required Special Tools:**

- MB991958 Scan Tool (M.U.T.-III Sub Assembly)
 - MB991824: Vehicle Communication Interface (V.C.I.)
 - MB991827 M.U.T.-III USB Cable
 - MB991910 M.U.T.-III Main Harness A

STEP 1. Using scan tool MB991958, diagnose the CAN bus lines.

Using scan tool MB991958, diagnose the CAN bus lines.

Q: Is the check result normal?

YES : Go to Step 3.

NO : Repair the CAN bus lines. (Refer to GROUP 54C – Troubleshooting [P.54C-15.](#)) After repairing the CAN bus line, go to Step 2.

STEP 2. DTC recheck after repairing the CAN bus line**Q: Is DTC C123B set?**

YES : Go to Step 3.

NO : This diagnosis is complete.

STEP 3. Scan tool diagnostic trouble code

Check that DTCs C100A, C1015, C1020, C102B, C1011, C101C, C1027, C1032, C1014, C101F, C102A, C1035, C1041, C1042, C1043, C1044, C1219, C2205, C123C, and C2204 are also set.

Q: Are DTCs C100A, C1015, C1020, C102B, C1011, C101C, C1027, C1032, C1014, C101F, C102A, C1035, C1041, C1042, C1043, C1044, C1219, C2205, C123C, and C2204 also set?

YES : Carry out the diagnosis for the diagnostic trouble code that is set. (Refer to [P.35C-22.](#)) Then go to Step 10.

NO : Go to Step 4.

STEP 4. Check of G and yaw rate sensor installation status

Check that the G and yaw rate sensor is installed correctly.

Q: Is the check result normal?

YES : After checking the G and yaw rate sensor, perform the calibration of the G and yaw rate sensor to make ASC-ECU relearn the neutral point.(Refer to [P.35C-287.](#)) Then go to Step 5.

NO : Reinstall the G and yaw rate sensor correctly. (Refer to [P.35C-304.](#)) Then go to Step 10.

STEP 5. Scan tool service data

Check the following service data. (Refer to [P.35C-276.](#))

- Item 08: Lateral G sensor
- Item 09: G sensor
- Item 12: Yaw rate sensor

Q: Is the check result normal?

YES : Go to Step 6.

NO : Replace the G and yaw rate sensor. (Refer to [P.35C-304.](#)) Then go to Step 10.

STEP 6. Check of steering wheel sensor installation status

Check that the steering wheel sensor is installed correctly.

Q: Is the check result normal?

YES : Go to Step 7.

NO : Install the steering wheel sensor correctly. (Refer to [P.35C-305.](#)) Then go to Step 7.

STEP 7. Wheel alignment check

Refer to GROUP 33 –On-vehicles service [P.33-8.](#)

Q: Is the check result normal?

YES : After checking the wheel alignment, perform the calibration of steering wheel sensor to make ASC-ECU relearn the neutral point. (Refer to [P.35C-289.](#)) Then go to Step 8.

NO : After adjusting the wheel alignment, perform the calibration of steering wheel sensor to make ASC-ECU relearn the neutral point. (Refer to [P.35C-289.](#)) Then go to Step 8.

STEP 8. Scan tool service data

Check the following service data. (Refer to [P.35C-276.](#))

- Item 11: Steering angle

Q: Is the check result normal?

YES : Go to Step 9.

NO : Replace the steering wheel sensor. (Refer to [P.35C-305.](#)) Then go to Step 10.

STEP 9. Check whether the DTC is reset.

Drive the vehicle for 15 seconds or more at 25 mph (40 km/h) or higher.

Q: Is DTC C123B set?

YES : Replace the hydraulic unit (incorporates in ASC-ECU). (Refer to [P.35C-298.](#)) Then go to Step 10.

NO : Intermittent malfunction. (Refer to GROUP 00 –How to Cope with Intermittent Malfunction [P.00-15.](#))

STEP 10. Check whether the DTC is reset.

Drive the vehicle for 15 seconds or more at 25 mph (40 km/h) or higher.

Q: Is DTC C123B set?

YES : Return to Step 1.

NO : The procedure is complete.

DTC C2200: Abnormality in ASC-ECU

⚠ CAUTION

- If there is any problem in the CAN bus lines, an incorrect diagnostic trouble code may be set. Prior to this diagnosis, diagnose the CAN bus lines.
- Whenever the ECU is replaced, ensure that the CAN bus lines are normal.
- When the hydraulic unit (integrated with ASC-ECU) is replaced, always perform the calibration of steering wheel sensor, G and yaw rate sensor, brake fluid pressure sensor, cut valve, and inlet valve. (Refer to [P.35C-287](#), [P.35C-289](#), [P.35C-294](#), and [P.35C-295](#).)

CIRCUIT OPERATION

ASC-ECU controls ASC by calculating the data sent from the wheel speed sensor, steering wheel sensor, and G and yaw rate sensor.

DTC SET CONDITIONS

This diagnostic trouble code is set when ASC-ECU has malfunction.

PROBABLE CAUSES

ASC-ECU malfunction

DIAGNOSIS**Required Special Tools:**

- MB991958 Scan Tool (M.U.T.-III Sub Assembly)
 - MB991824: Vehicle Communication Interface (V.C.I.)
 - MB991827 M.U.T.-III USB Cable
 - MB991910 M.U.T.-III Main Harness A

STEP 1. Using scan tool MB991958, diagnose the CAN bus lines.

Using scan tool MB991958, diagnose the CAN bus lines.

Q: Is the check result normal?

YES : Go to Step 2.

NO : Repair the CAN bus lines. (Refer to GROUP 54C – Troubleshooting [P.54C-15](#).) After repairing the CAN bus line, go to Step 3.

STEP 2. Check whether the DTC is reset.**Q: Is DTC C2200 set?**

YES : Replace the hydraulic unit (incorporates in ASC-ECU). (Refer to [P.35C-298](#).) Then go to Step 3.

NO : Intermittent malfunction. (Refer to GROUP 00 –How to Cope with Intermittent Malfunction [P.00-15](#).)

STEP 3. Check whether the DTC is reset.

Q: Is DTC C2200 set?

YES : Return to Step 1.

NO : This diagnosis is complete.

DTC C2101: Abnormality in battery voltage (high voltage)

Solenoid Valve, Motor and ASC-ECU Power Supply Circuit

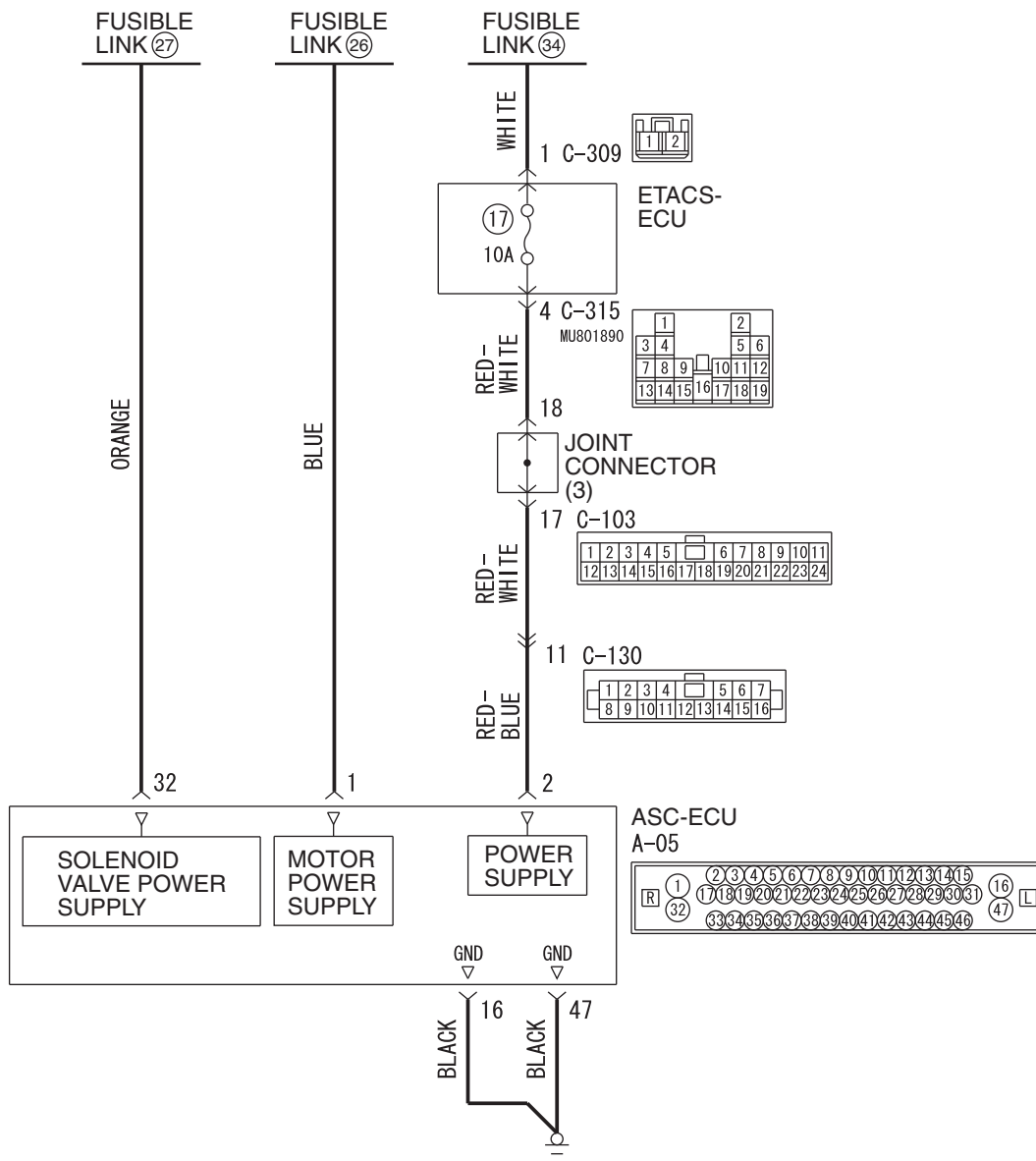

AC804606

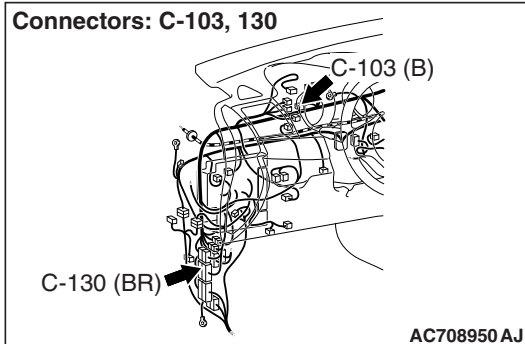
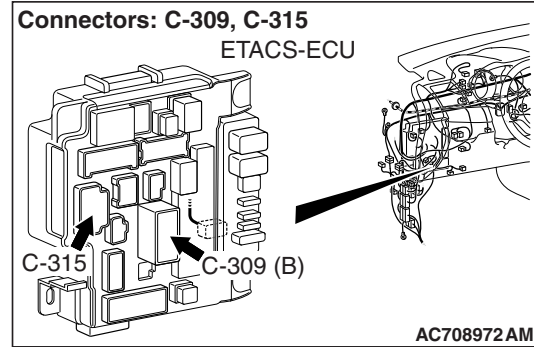
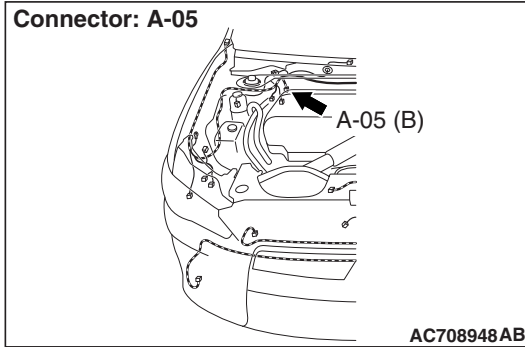

⚠ CAUTION

- If there is any problem in the CAN bus lines, an incorrect diagnostic trouble code may be set. Prior to this diagnosis, diagnose the CAN bus lines.
- Whenever the ECU is replaced, ensure that the CAN bus lines are normal.
- When the hydraulic unit (integrated with ASC-ECU) is replaced, always perform the calibration of steering wheel sensor, G and yaw rate sensor, brake fluid pressure sensor, cut valve, and inlet valve. (Refer to [P.35C-287](#), [P.35C-289](#), [P.35C-294](#), and [P.35C-295](#).)

CIRCUIT OPERATION

- ASC-ECU contains the power supply circuit (terminal No. 32) for the solenoid valve. The solenoid valve is energized by the valve relay, which is incorporated in ASC-ECU.
- ASC-ECU contains the power supply circuit (terminal No. 2) for ASC-ECU, and the power is supplied from the fusible link No. 34 through the multi-purpose fuse No. 17.
- The valve relay in ASC-ECU is energized at all times, and the solenoid valve is always energized while the system is in operation unless the initial check is in progress when the ignition switch is turned ON, or unless the periodical system check is in progress.

DTC SET CONDITIONS

This diagnostic trouble code is set when the ASC-ECU power supply voltage and solenoid valve power supply voltage become 18.0 ± 1.0 V or higher.

PROBABLE CAUSES

- Battery failure
- Battery terminal looseness
- Fusible link malfunction
- Damaged wiring harness and connectors
- ASC-ECU malfunction
- Charging system failed

DIAGNOSIS

Required Special Tools:

- MB991958 Scan Tool (M.U.T.-III Sub Assembly)
 - MB991824: Vehicle Communication Interface (V.C.I.)
 - MB991827 M.U.T.-III USB Cable
 - MB991910 M.U.T.-III Main Harness A
- MB991997: ASC check harness

STEP 1. Using scan tool MB991958, diagnose the CAN bus lines.

Using scan tool MB991958, diagnose the CAN bus lines.

Q: Is the check result normal?

YES : Go to Step 3.

NO : Repair the CAN bus lines (Refer to GROUP 54C – CAN Bus Diagnosis table [P.54C-15](#)). On completion, go to Step 2.

STEP 2. DTC recheck after repairing the CAN bus line

Q: Is DTC C2101 set?

YES : Go to Step 3.

NO : The procedure is complete.

STEP 3. Battery terminal check

Check that the battery terminal is not loose.

Q: Is the check result normal?

YES : Go to Step 4.

NO : Securely install the battery terminal. Then go to Step 4.

STEP 4. Battery check

Refer to GROUP 54A –Battery Test [P.54A-9](#).

Q: Is the battery in good condition?

YES : Go to Step 6.

NO : Charge or replace the battery, and then go to Step 5.

STEP 5. Charging system check

Refer to GROUP 16 –Charging System [P.16-7](#).

Q: Is the charging system in good condition?

YES : Go to Step 6.

NO : Repair or replace the charging system component(s).

STEP 6. Connector check: A-05 ASC-ECU connector, C-309 ETACS-ECU connector and C-315 ETACS-ECU connector, C-103 joint connector, C-130 intermediate connector

Q: Is the check result normal?

YES : Go to Step 7.

NO : Repair the defective connector.

STEP 7. Fusible link check: Check the fusible link No.27.

Check that the fusible link No. 27 is normal and does not exceed the capacity.

Q: Is the check result normal?

YES : Go to Step 9.

NO : Go to Step 8.

STEP 8. Resistance measurement at A-05 ASC-ECU connector

(1) Disconnect the connector, connect the special tool ASC check harness (MB991997) to the wiring harness-side connector, and then measure the resistance at the special tool connector side.

NOTE: Do not connect the special tool to ASC-ECU.

(2) Measure the resistance between the terminal No. 32 and the body ground.

OK: No continuity

Q: Is the check result normal?

YES : Replace the fusible link No.27. Then go to Step 15.

NO : The short circuit may be present in the power supply circuit. Repair the wiring harness between the A-05 ASC-ECU connector terminal No.32 and the fusible link No.27, and then replace the fusible link No.27. Then go to Step 15.

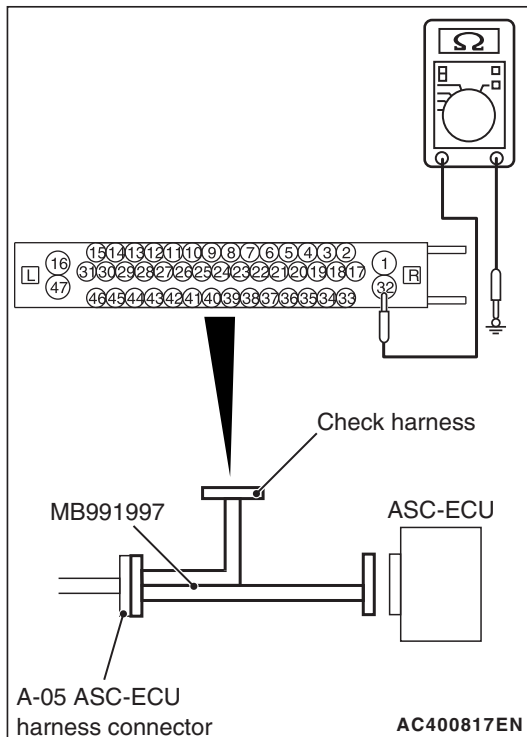

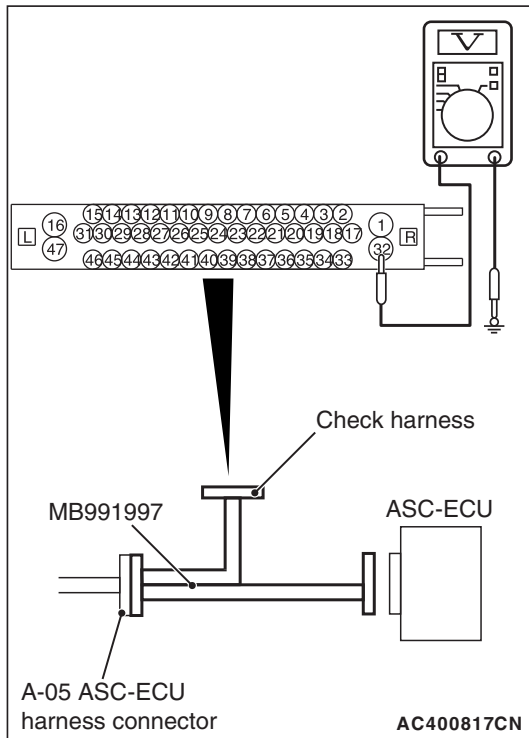

STEP 9. Voltage measurement at the A-05 ASC-ECU connector

- (1) Disconnect the connector, connect the special tool ASC check harness (MB991997) to the wiring harness-side connector, and measure the voltage at the special tool connector side.

NOTE: Do not connect the special tool to ASC-ECU.

- (2) Measure the voltage between the terminal No. 32 and the body ground.

OK: Battery positive voltage

Q: Is the check result normal?

YES : Go to Step 10.

NO : The open circuit may be present in the power supply circuit. Repair the wiring harness between the A-05 ASC-ECU connector terminal No.32 and the fusible link No.27. Then go to Step 15.

STEP 10. Fusible link check: Check the fusible link No. 34.

Check that the fusible link No. 34 is normal and does not exceed the capacity.

Q: Is the check result normal?

YES : Go to Step 12.

NO : Go to Step 11.

STEP 11. Resistance measurement at C-309 ETACS-ECU connector

- (1) Removal the fusible link No.34.
- (2) Disconnect the C-309 ETACS-ECU connector, and then measure the resistance at the connector side.
- (3) Measure the resistance between the terminal No.1 and the body ground.

OK: No continuity

Q: Is the check result normal?

YES : Replace the fusible link No.34. Then go to Step 15.

NO : The short circuit may be present in the power supply circuit. Repair the wiring harness between the C-309 ETACS-ECU connector terminal No.1 and the fusible link No.34, and then replace the fusible link No.34. Then go to Step 15.

STEP 12. Resistance measurement at fusible link No.34 and C-309 ETACS-ECU connector

- (1) Disconnect the C-309 ETACS-ECU connector and fusible link No.34, and then measure the resistance at the harness connector side.
- (2) Measure the resistance between the fusible link No.34 and C-309 ETACS-ECU connector terminal No.1.

OK: Continuity exists (2 Ω or less)

Q: Is the check result normal?

YES : Go to Step 13.

NO : The open circuit may be present in the power supply circuit. Repair the wiring harness between the fusible link No.34 and C-309 ETACS-ECU connector terminal No.1. Then go to Step 15.

STEP 13. Resistance measurement at A-05 ASC-ECU connector

- (1) Disconnect the connector, connect the special tool ASC check harness (MB991997) to the wiring harness-side connector, and measure the resistance at the special tool connector side.

NOTE: Do not connect the special tool to ASC-ECU.

- (2) Measure the resistance between the terminal No. 16 and the body ground as well as between the terminal No. 47 and the body ground.

OK: Continuity exists (2 Ω or less)

Q: Is the check result normal?

YES : Go to Step 14.

NO : Repair the wiring harness.

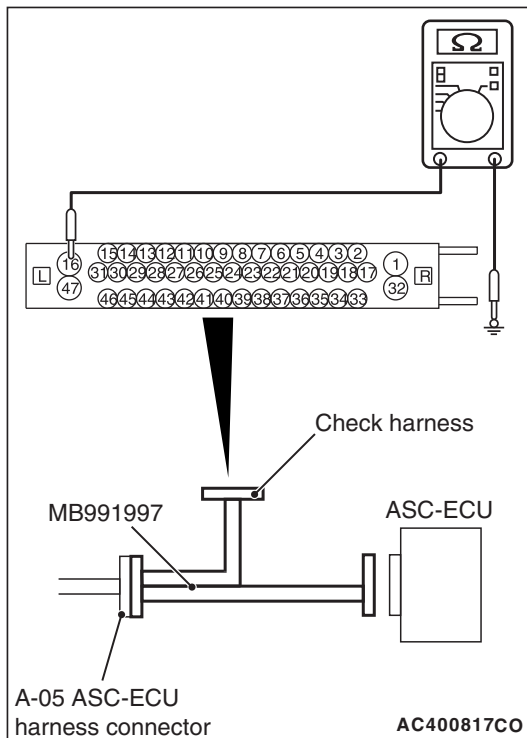
**STEP 14. Check whether the DTC is reset.****Q: Is DTC C2101 set?**

YES : Replace the hydraulic unit (incorporates in ASC-ECU). (Refer to [P.35C-298.](#)) Then go to Step 15.

NO : Intermittent malfunction. (Refer to GROUP 00 –How to Cope with Intermittent Malfunction [P.00-15.](#))

STEP 15. Check whether the DTC is reset.

Q: Is DTC C2101 set?

YES : Return to Step 1.

NO : The procedure is complete.

DTC C1395: Brake fluid filling not completed

 **CAUTION**

- If there is any problem in the CAN bus lines, an incorrect diagnostic trouble code may be set. Prior to this diagnosis, diagnose the CAN bus lines.
- Whenever the ECU is replaced, ensure that the CAN bus lines are normal.
- When the hydraulic unit (integrated with ASC-ECU) is replaced, always perform the calibration of steering wheel sensor, G and yaw rate sensor, brake fluid pressure sensor, cut valve, and inlet valve.(Refer to [P.35C-287](#), [P.35C-289](#), [P.35C-294](#), and [P.35C-295](#).)

DTC SET CONDITIONS

This diagnostic trouble code is set when the brake fluid is not filled in the hydraulic unit.

PROBABLE CAUSES

- Different hydraulic unit (For delivery to factory)
- ASC-ECU malfunction

DIAGNOSIS

Required Special Tools:

- MB991958 Scan Tool (M.U.T.-III Sub Assembly)
 - MB991824: V.C.I.
 - MB991827 M.U.T.-III USB Cable
 - MB991910 M.U.T.-III Main Harness A

STEP 1. Using scan tool MB991958, diagnose the CAN bus lines.

Using scan tool MB991958, diagnose the CAN bus lines.

Q: Is the check result normal?

YES : Go to Step 2.

NO : Repair the CAN bus lines. (Refer to GROUP 54C – Troubleshooting [P.54C-15](#).) After repairing the CAN bus line, go to Step 2.

STEP 2. DTC recheck after repairing the CAN bus line

Q: Is DTC C1395 set?

YES : Replace the hydraulic unit (incorporates in ASC-ECU).(Refer to [P.35C-298](#).)

NO : The procedure is complete.

DTC C121C: Torque request signal rejection

⚠ CAUTION

- If there is any problem in the CAN bus lines, an incorrect diagnostic trouble code may be set. Prior to this diagnosis, diagnose the CAN bus lines.
- Whenever the ECU is replaced, ensure that the CAN bus lines are normal.
- When the hydraulic unit (integrated with ASC-ECU) is replaced, always perform the calibration of steering wheel sensor, G and yaw rate sensor, brake fluid pressure sensor, cut valve, and inlet valve.(Refer to [P.35C-287](#), [P.35C-289](#), [P.35C-294](#), and [P.35C-295](#).)

CIRCUIT OPERATION

ASC-ECU sends the signal to the engine control module as necessary to decrease the engine output for ASC system operation.

DTC SET CONDITIONS

This diagnostic trouble code is set when the output decrease request is rejected by the engine control module.

PROBABLE CAUSES

- Wrong coding
- Engine ECU malfunction
- ASC-ECU malfunction
- External noise interference

DIAGNOSIS**Required Special Tools:**

- MB991958 Scan Tool (M.U.T.-III Sub Assembly)
 - MB991824: Vehicle Communication Interface (V.C.I.)
 - MB991827 M.U.T.-III USB Cable
 - MB991910 M.U.T.-III Main Harness A

STEP 1. Using scan tool MB991958, diagnose the CAN bus lines.

Using scan tool MB991958, diagnose the CAN bus lines.

Q: Is the check result normal?

YES : Go to Step 3.

NO : Repair the CAN bus lines. (Refer to GROUP 54C – Troubleshooting [P.54C-15](#).) After repairing the CAN bus line, go to Step 2.

STEP 2. DTC recheck after repairing the CAN bus line**Q: Is DTC C121C set?**

YES : Go to Step 3.

NO : The procedure is complete.

STEP 3. M.U.T.-III other system diagnostic trouble code

Using scan tool MB991958, check if a diagnostic trouble code is set in the engine control module. (Refer to GROUP 13A – Troubleshooting P.13A-48.)

Q: Is any DTC set?

YES : Troubleshoot the diagnostic trouble code of engine control module. (Refer to GROUP 13A – Troubleshooting P.13A-48.)

NO : Go to Step 4.

STEP 4. Scan tool service data

Check the following service data. (Refer to P.35C-276.)

- Item 68: Allow ESP torque request

Q: Is the check result normal?

YES : Go to Step 5.

NO : Replace the engine control module. (Refer to GROUP 13A –Engine Control Module P.13A-888.) Then go to Step 5.

STEP 5. Check whether the DTC is reset.

Q: Is DTC C121C set?

YES : Replace the hydraulic unit (incorporates in ASC-ECU).(Refer to P.35C-298.) Then go to Step 6.

NO : Intermittent malfunction. (Refer to GROUP 00 –How to Cope with Intermittent Malfunction P.00-15.)

STEP 6. Check whether the DTC is reset.

Q: Is DTC C121C set?

YES : Return to Step 1.

NO : The procedure is complete.

DTC C1290: CAN time-out error

⚠ CAUTION

- If diagnostic trouble code No. C1290 is set in ASC-ECU, always diagnose the CAN bus lines. If there is any fault in the CAN bus lines, an incorrect DTC may be set.
- When the diagnostic trouble code No. C1290 is set in ASC-ECU, a diagnostic trouble code for another system may also be set. When the diagnostic trouble code for another system is set, carry out diagnosis for that system first.
- Whenever the ECU is replaced, ensure that the communication circuit is normal.
- When the steering wheel sensor is replaced, always perform calibration to make ASC-ECU learn the neutral point. (Refer to [P.35C-289](#).)
- When the hydraulic unit (integrated with ASC-ECU) is replaced, always perform the calibration of steering wheel sensor, G and yaw rate sensor, brake fluid pressure sensor, cut valve, and inlet valve.(Refer to [P.35C-287](#), [P.35C-289](#), [P.35C-294](#), and [P.35C-295](#).)

CIRCUIT OPERATION

ASC-ECU receives signals necessary for the operations of ABS, stability control, and TCL from the engine control module, transaxle assembly (with built-in ECU) <TC-SST>, S-AWC-ECU, ETACS-ECU, and the steering wheel sensor via the CAN bus lines.

DTC SET CONDITIONS

This diagnostic trouble code is stored if ASC-ECU cannot receive signals necessary for the operations of ABS, stability control, and TCL from the engine control module, transaxle assembly (with built-in ECU) <TC-SST>, S-AWC-ECU, ETACS-ECU, and the steering wheel sensor.

PROBABLE CAUSES

- ECM malfunction
- Malfunction of transaxle assembly <TC-SST>
- S-AWC-ECU malfunction
- ETACS-ECU malfunction
- Steering wheel sensor malfunction
- Malfunction of the CAN bus
- ASC-ECU malfunction
- Interchanging of ETACS-ECU with another vehicle

DIAGNOSIS

Required Special Tools:

- MB991958 Scan Tool (M.U.T.-III Sub Assembly)
 - MB991824: Vehicle Communication Interface (V.C.I.)
 - MB991827 M.U.T.-III USB Cable
 - MB991910 M.U.T.-III Main Harness A

STEP 1. Using scan tool MB991958, diagnose the CAN bus lines.

Using scan tool MB991958, diagnose the CAN bus lines.

Q: Is the check result normal?

YES : Go to Step 2.

NO : Repair the CAN bus lines. (Refer to GROUP 54C – Troubleshooting [P.54C-15](#).) After repairing the CAN bus line, go to Step 4.

STEP 2. Scan tool diagnostic trouble code

Check that diagnostic trouble code U0100, U0101, U0126, U0141, U0136 or U0251 is set in ASC-ECU.

Q: Is any DTC set?

YES : Perform troubleshooting for the diagnostic trouble code that is set. (Refer to [P.35C-22](#).)

NO : Go to Step 3.

STEP 3. Scan tool diagnostic trouble code for other systems

Using scan tool MB991958, check if the diagnostic trouble codes are set from the engine control module, transaxle assembly (with built-in ECU) <TC-SST>, S-AWC-ECU, and ETACS-ECU.

Q: Is any DTC set?

YES : Perform troubleshooting for the diagnostic trouble code that is set. Then go to Step 4.

NO : Go to Step 4.

STEP 4. ETACS-ECU coding data check

Check the following coding data stored in ETACS-ECU. (Refer to GROUP 00 –Coding Table [P.00-26.](#))

Vehicle line

OK: LANCER EVO

Transaxle

OK (Vehicles without TC-SST): 5MT

OK (Vehicles with TC-SST): TC-SST

Engine type

OK: D4 V.V.T. 2.0L TC

Engine power

OK: Normal

Chassis Type for A.S.C.

OK: Type 1

Final drive

OK: AWD FF Base

Transfer

OK: ACD

SAS

OK: Present

AWD

OK: Not present

TCM

OK (Vehicles without TC-SST): Not present

OK (Vehicles with TC-SST): Present

ACDAYC

OK: Present

Q: Is the check result normal?

YES : Go to Step 5.

NO : Replace the ETACS-ECU. (Refer to GROUP 54A – ETACS-ECU [P.54A-742.](#)) Then go to Step 6.

STEP 5. Check whether the DTC is reset.**Q: Is DTC C1290 set?**

YES : Replace the hydraulic unit (incorporates in ASC-ECU).(Refer to [P.35C-298.](#)) Then go to Step 6.

NO : Intermittent malfunction. (Refer to GROUP 00 –How to Cope with Intermittent Malfunction [P.00-15.](#))

STEP 6. Check whether the DTC is reset.**Q: Is DTC C1290 set?**

YES : Return to Step 1.

NO : The procedure is complete.

DTC C2203: VIN not recorded

 **CAUTION**

- If there is any problem in the CAN bus lines, an incorrect diagnostic trouble code may be set. Prior to this diagnosis, diagnose the CAN bus lines.
- When another diagnostic trouble code for ASC-ECU is set, troubleshoot that diagnostic trouble code first.
- Whenever the ECU is replaced, ensure that the CAN bus lines are normal.
- This diagnostic trouble code is set after ASC-ECU is swapped and the ignition switch is turned ON for the first time. However, on and after the second time, the diagnostic trouble code will not be set when ASC-ECU successfully receives the normal vehicle information from the engine control module.
- When the hydraulic unit (integrated with ASC-ECU) is replaced, always perform the calibration of steering wheel sensor, G and yaw rate sensor, brake fluid pressure sensor, cut valve, and inlet valve.(Refer to [P.35C-287](#), [P.35C-289](#), [P.35C-294](#), and [P.35C-295](#).)

CIRCUIT OPERATION

ASC-ECU receives vehicle information from the engine control module and stores it.

DTC SET CONDITIONS

This diagnostic trouble code is set when ASC-ECU cannot receive the vehicle information, after the ignition switch is turned ON, from the engine control module.

PROBABLE CAUSES

- Malfunction of the CAN bus
- Engine ECU malfunction
- ASC-ECU malfunction
- First ignition switch ON after replacement of ASC-ECU

DIAGNOSIS

Required Special Tools:

- MB991958 Scan Tool (M.U.T.-III Sub Assembly)
 - MB991824: Vehicle Communication Interface (V.C.I.)
 - MB991827 M.U.T.-III USB Cable
 - MB991910 M.U.T.-III Main Harness A

STEP 1. Using scan tool MB991958, diagnose the CAN bus lines.

Using scan tool MB991958, diagnose the CAN bus lines.

Q: Is the check result normal?

YES : Go to Step 3.

NO : Repair the CAN bus lines. (Refer to GROUP 54C – Troubleshooting [P.54C-15](#).) After repairing the CAN bus line, go to Step 2.

STEP 2. DTC recheck after repairing the CAN bus line

(1) Ignition switch "LOCK" (OFF)

(2) Ignition switch "ON"

Q: Is DTC C2203 set?

YES : Go to Step 3.

NO : The procedure is complete.

STEP 3. Scan tool diagnostic trouble code for other systems

Check if the engine control module sets a DTC. (Refer to GROUP 13A – Troubleshooting [P.13A-48](#).)

Q: Is any DTC set?

YES : Troubleshoot the diagnostic trouble code of engine control module. (Refer to GROUP 13A – Troubleshooting [P.13A-48](#).) Then go to Step 5.

NO : Go to Step 4.

STEP 4. Check whether the DTC is reset.

(1) Ignition switch: "LOCK" (OFF) position

(2) Ignition switch: "ON" position

Q: Is DTC C2203 set?

YES : Replace the hydraulic unit (incorporates in ASC-ECU).(Refer to [P.35C-298](#).) Then go to Step 5.

NO : Intermittent malfunction. (Refer to GROUP 00 –How to Cope with Intermittent Malfunction [P.00-15](#).)

STEP 5. Check whether the DTC is reset.

(1) Ignition switch: "LOCK" (OFF) position

(2) Ignition switch: "ON" position

Q: Is DTC C2203 set?

YES : Return to Step 1.

NO : The procedure is complete.

DTC C2206: Re-execution of variant coding

⚠ CAUTION

- If diagnostic trouble code No. C2206 is set in ASC-ECU, always diagnose the CAN bus lines. If there is any fault in the CAN bus lines, an incorrect DTC may be set.
- Whenever the ECU is replaced, ensure that the communication circuit is normal.
- When diagnostic trouble code No. C2206 is set in ASC-ECU, the diagnostic trouble code may also be set in ETACS-ECU. When the diagnostic trouble code is set in ETACS-ECU, perform the diagnosis of the diagnostic trouble code for ETACS-ECU first.
- When the hydraulic unit (integrated with ASC-ECU) is replaced, always perform the calibration of steering wheel sensor, G and yaw rate sensor, brake fluid pressure sensor, cut valve, and inlet valve.(Refer to [P.35C-287](#), [P.35C-289](#), [P.35C-294](#), and [P.35C-295](#).)

CIRCUIT OPERATION

ASC-ECU receives the vehicle information stored in ETACS-ECU via CAN bus lines.

DTC SET CONDITIONS

ASC-ECU communicates with ETACS-ECU via CAN bus lines. This diagnostic trouble code is set if the vehicle information stored in ETACS-ECU has been altered from the one that was stored at the previous ignition switch ON.

PROBABLE CAUSES

- ETACS-ECU or ASC-ECU which was equipped with other vehicle is used.
- Malfunction of ETACS-ECU
- ASC-ECU malfunction
- External noise interference

DIAGNOSIS**Required Special Tools:**

- MB991958 Scan Tool (M.U.T.-III Sub Assembly)
 - MB991824: Vehicle Communication Interface (V.C.I.)
 - MB991827 M.U.T.-III USB Cable
 - MB991910 M.U.T.-III Main Harness A

STEP 1. Using scan tool MB991958, diagnose the CAN bus lines.

Using scan tool MB991958, diagnose the CAN bus lines.

Q: Is the check result normal?

YES : Go to Step 2.

NO : Repair the CAN bus lines. (Refer to GROUP 54C – Troubleshooting [P.54C-15](#).) After repairing the CAN bus line, go to Step 7.

STEP 2. Scan tool diagnostic trouble code

Check that the diagnostic trouble code U1415 or U1417 is set in ASC-ECU.

Q: Is any DTC set?

YES : Perform troubleshooting for the diagnostic trouble code that is set. (Refer to [P.35C-22.](#))

NO : Go to Step 3.

STEP 3. Scan tool diagnostic trouble code for other systems

Use scan tool to check that the vehicles information-related DTC is set by the ETACS-ECU.

Q: Is any DTC set?

YES : Troubleshoot the relevant diagnostic trouble code, and then go to Step 4.

NO : Go to Step 4.

STEP 4. ETACS-ECU coding data check

Check the following coding data stored in ETACS-ECU. (Refer to GROUP 00 –Coding Table [P.00-26.](#))

Vehicle line

OK: LANCER EVO

Transmission

OK (Vehicles without TC-SST): 5MT

OK (Vehicles with TC-SST): TC-SST

Engine type

OK: D4 V.V.T. 2.0L TC

Engine power

OK: Normal

Chassis Type for A.S.C.

OK: Type 1

Final drive

OK: AWD FF Base

Transfer

OK: ACD

SAS

OK: Present

AWD

OK: Not present

TCM

OK (Vehicles without TC-SST): Not present

OK (Vehicles with TC-SST): Present

ACDAYC

OK: Present

Q: Is the check result normal?

YES : Go to Step 6.

NO : Go to Step 5.

STEP 5. ETACS-ECU variant coding

Perform the variant coding to the ETACS-ECU.

Q: Dose variant coding succeed?

YES : Go to Step 7.

NO : Replace the ETACS-ECU (Refer to GROUP 54A – ETACS-ECU [P.54A-742](#)), and then go to Step 7.

STEP 6. Check whether the DTC is reset.

(1) Ignition switch: "LOCK" (OFF) position.

(2) Ignition switch: "ON" position.

Q: Is DTC C2206 set?

YES : Replace the hydraulic unit (incorporates in ASC-ECU).(Refer to [P.35C-298](#).) Then go to Step 7.

NO : The procedure is complete.

STEP 7. Check whether the DTC is reset.

(1) Ignition switch: "LOCK" (OFF) position.

(2) Ignition switch: "ON" position.

Q: Is DTC C2206 set?

YES : Return to Step 1.

NO : The procedure is complete.

DTC C1210: Abnormality in G and yaw rate sensor (longitudinal G sensor)

⚠ CAUTION

- If there is any problem in the CAN bus lines, an incorrect diagnostic trouble code may be set. Prior to this diagnosis, diagnose the CAN bus lines.
- Whenever the ECU is replaced, ensure that the CAN bus lines are normal.
- When the steering wheel sensor is replaced, always perform calibration to make ASC-ECU learn the neutral point. (Refer to [P.35C-289](#).)
- Do not drop the G and yaw rate sensor or subject it to a shock.
- When the G and yaw rate sensor is replaced, always perform the calibration to make ASC-ECU learn the neutral point. (Refer to [P.35C-287](#).)
- When the hydraulic unit (integrated with ASC-ECU) is replaced, always perform the calibration of steering wheel sensor, G and yaw rate sensor, brake fluid pressure sensor, cut valve, and inlet valve.(Refer to [P.35C-287](#), [P.35C-289](#), [P.35C-294](#), and [P.35C-295](#).)

CIRCUIT OPERATION

- ASC-ECU supplies power to the G and yaw rate sensor at the terminal No. 1.
- The G and yaw rate sensor outputs the signal to ASC-ECU via the local CAN bus lines.

DTC SET CONDITIONS

This diagnostic trouble code is set if any malfunction below is detected.

- Longitudinal G value output from G and yaw rate sensor is abnormal.
- Abnormality is detected by the self-diagnosis of the longitudinal G sensor.

PROBABLE CAUSES

- G and yaw rate sensor malfunction
- ASC-ECU malfunction
- External noise interference
- The G and yaw rate sensor for FWD is installed.

DIAGNOSIS**Required Special Tools:**

- MB991958 Scan Tool (M.U.T.-III Sub Assembly)
 - MB991824: Vehicle Communication Interface (V.C.I.)
 - MB991827 M.U.T.-III USB Cable
 - MB991910 M.U.T.-III Main Harness A

STEP 1. Using scan tool MB991958, diagnose the CAN bus lines.

Using scan tool MB991958, diagnose the CAN bus lines.

Q: Is the check result normal?

YES : Go to Step 3.

NO : Repair the CAN bus lines. (Refer to GROUP 54C – Troubleshooting [P.54C-15.](#)) After repairing the CAN bus line, go to Step 2.

STEP 2. Check whether the DTC is reset.**Q: Is DTC C1210 set?**

YES : Go to Step 3.

NO : This diagnosis is complete.

STEP 3. Scan tool service data

Check the following service data. (Refer to [P.35C-276.](#))

- Item 09: G sensor

Q: Is the check result normal?

YES : Go to Step 4.

NO : Go to Step 5.

STEP 4. Check of G and yaw rate sensor part number**Q: Is the check result normal?**

YES : After checking the G and yaw rate sensor, perform the calibration of the G and yaw rate sensor to make ASC-ECU relearn the neutral point.(Refer to [P.35C-287.](#)) Then go to Step 5.

NO : Replace the G and yaw rate sensor. (Refer to [P.35C-304.](#)) Then go to Step 6.

STEP 5. Check whether the DTC is reset.

Q: Is DTC C1210 set?

- YES** : Replace the G and yaw rate sensor. (Refer to [P.35C-304.](#)) Then go to Step 6.
NO : The procedure is complete.

STEP 6. Check whether the DTC is reset.

Q: Is DTC C1210 set?

- YES** : Replace the hydraulic unit (incorporates in ASC-ECU).(Refer to [P.35C-298.](#)) Then go to Step 7.
NO : Intermittent malfunction. (Refer to GROUP 00 –How to Cope with Intermittent Malfunction [P.00-15.](#))

STEP 7. Check whether the DTC is reset.

Q: Is DTC C1210 set?

- YES** : Return to Step 1.
NO : The procedure is complete.

DTC C1242: Abnormality in G and yaw rate sensor (longitudinal G sensor)

⚠ CAUTION

- If there is any problem in the CAN bus lines, an incorrect diagnostic trouble code may be set. Prior to this diagnosis, diagnose the CAN bus lines.
- Whenever the ECU is replaced, ensure that the CAN bus lines are normal.
- Do not drop the G and yaw rate sensor or subject it to a shock.
- When the G and yaw rate sensor is replaced, always perform the calibration to make ASC-ECU learn the neutral point. (Refer to [P.35C-287.](#))
- When the hydraulic unit (integrated with ASC-ECU) is replaced, always perform the calibration of steering wheel sensor, G and yaw rate sensor, brake fluid pressure sensor, cut valve, and inlet valve.(Refer to [P.35C-287](#), [P.35C-289](#), [P.35C-294](#), and [P.35C-295.](#))

CIRCUIT OPERATION

- ASC-ECU supplies power to the G and yaw rate sensor at the terminal No. 1.
- The G and yaw rate sensor outputs the signal to ASC-ECU via the local CAN bus lines.

DTC SET CONDITIONS

This diagnostic trouble code is set when an abnormality is detected by a comparison of the longitudinal G value output from G and yaw rate sensor with the wheel speed value output from wheel speed sensor.

PROBABLE CAUSES

- Improper installation of the G and yaw rate sensor
- G and yaw rate sensor malfunction
- Wheel speed sensor malfunction
- ASC-ECU malfunction
- External noise interference

NOTE: This DTC may be set also when the vehicle is driven on the four-wheel drum tester.

DIAGNOSIS**Required Special Tools:**

- MB991958 Scan Tool (M.U.T.-III Sub Assembly)
 - MB991824: Vehicle Communication Interface (V.C.I.)
 - MB991827 M.U.T.-III USB Cable
 - MB991910 M.U.T.-III Main Harness A

STEP 1. Using scan tool MB991958, diagnose the CAN bus lines.

Using scan tool MB991958, diagnose the CAN bus lines.

Q: Is the check result normal?

YES : Go to Step 2.

NO : Repair the CAN bus lines. (Refer to GROUP 54C – Troubleshooting [P.54C-15](#).) After repairing the CAN bus line, go to Step 2.

STEP 2. Check for diagnostic trouble codes of other systems

Check if diagnostic trouble code No. U0125 is also set in ASC-ECU.

Q: Is DTC U0125 set?

YES : Perform troubleshooting for the diagnostic trouble code that is set. (Refer to [P.35C-212](#).) Then go to Step 3.

NO : Go to Step 3.

STEP 3. Check whether the DTC is reset.**Q: Is DTC C1242 set?**

YES : Go to Step 4.

NO : This diagnosis is complete.

STEP 4. Check of wheel speed sensor-related diagnostic trouble code

Using scan tool MB991958, check if the wheel speed sensor-related diagnostic trouble code is set. (Refer to [P.35C-22](#).)

Q: Is any DTC set?

YES : Perform troubleshooting for the diagnostic trouble code that is set. (Refer to [P.35C-22](#).)

NO : Go to Step 5.

STEP 5. G and yaw rate sensor check

Check that the G and yaw rate sensor is installed correctly.

Q: Is the check result normal?

YES : After checking the G and yaw rate sensor, perform the calibration of the G and yaw rate sensor to make ASC-ECU relearn the neutral point.(Refer to [P.35C-287.](#)) Then go to Step 6.

NO : Reinstall the G and yaw rate sensor correctly. (Refer to [P.35C-304.](#)) Then go to Step 8.

STEP 6. Scan tool service data

Check the following service data. (Refer to [P.35C-276.](#))

- Item 09: G sensor
- Item 96: G sensor offset

Q: Is the check result normal?

YES : Go to Step 7.

NO : Replace the G and yaw rate sensor. (Refer to [P.35C-304.](#)) Then go to Step 7.

STEP 7. Check whether the DTC is reset.

Q: Is DTC C1242 set?

YES : Replace the hydraulic unit (incorporates in ASC-ECU).(Refer to [P.35C-298.](#)) Then go to Step 8.

NO : Intermittent malfunction. (Refer to GROUP 00 –How to Cope with Intermittent Malfunction [P.00-15.](#))

STEP 8. Check whether the DTC is reset.

Q: Is DTC C1242 set?

YES : Return to Step 1.

NO : The procedure is complete.

DTC C123C: Abnormality in G and yaw rate sensor (lateral G or yaw rate)

⚠ CAUTION

- If there is any problem in the CAN bus lines, an incorrect diagnostic trouble code may be set. Prior to this diagnosis, diagnose the CAN bus lines.
- Whenever the ECU is replaced, ensure that the CAN bus lines are normal.
- When the steering wheel sensor is replaced, always perform calibration to make ASC-ECU learn the neutral point. (Refer to [P.35C-289](#).)
- Do not drop the G and yaw rate sensor or subject it to a shock.
- When the G and yaw rate sensor is replaced, always perform the calibration to make ASC-ECU learn the neutral point. (Refer to [P.35C-287](#).)
- When the hydraulic unit (integrated with ASC-ECU) is replaced, always perform the calibration of steering wheel sensor, G and yaw rate sensor, brake fluid pressure sensor, cut valve, and inlet valve. (Refer to [P.35C-287](#), [P.35C-289](#), [P.35C-294](#), and [P.35C-295](#).)

CIRCUIT OPERATION

- ASC-ECU supplies power to the G and yaw rate sensor at the terminal No. 1.
- The G and yaw rate sensor outputs the signal to ASC-ECU via the local CAN bus lines.

DTC SET CONDITIONS

This diagnostic trouble code is set if any malfunction below is found:

- Lateral G value or yaw rate value output from G and yaw rate sensor is abnormal.
- When abnormality is detected by comparing the value output from the lateral G and yaw rate with the one from the steering wheel sensor and wheel speed sensor

PROBABLE CAUSES

- Improper installation of the G and yaw rate sensor
- G and yaw rate sensor malfunction
- Steering wheel sensor malfunction
- Improper installation of steering wheel sensor
- Malfunction of wheel speed sensor
- ASC-ECU malfunction
- External noise interference

DIAGNOSIS**Required Special Tools:**

- MB991958 Scan Tool (M.U.T.-III Sub Assembly)
 - MB991824: Vehicle Communication Interface (V.C.I.)
 - MB991827 M.U.T.-III USB Cable
 - MB991910 M.U.T.-III Main Harness A

STEP 1. Using scan tool MB991958, diagnose the CAN bus lines.

Using scan tool MB991958, diagnose the CAN bus lines.

Q: Is the check result normal?

YES : Go to Step 2.

NO : Repair the CAN bus lines. (Refer to GROUP 54C – Troubleshooting [P.54C-15.](#)) After repairing the CAN bus line, go to Step 2.

STEP 2. Check for diagnostic trouble codes of other systems

Check if diagnostic trouble code No. U0125 is also set in ASC-ECU.

Q: Is DTC U0125 set?

YES : Perform troubleshooting for the diagnostic trouble code that is set. (Refer to [P.35C-212.](#)) Then go to Step 3.

NO : Go to Step 3.

STEP 3. Check whether the DTC is reset.

Q: Is DTC C123C set?

YES : Go to Step 4.

NO : The procedure is complete.

STEP 4. Check of wheel speed sensor-related diagnostic trouble code

Using scan tool MB991958, check if the wheel speed sensor-related or steering wheel sensor-related diagnostic trouble code is set. (Refer to [P.35C-22.](#))

Q: Is any DTC set?

YES : Perform troubleshooting for the diagnostic trouble code that is set. (Refer to [P.35C-22.](#))

NO : Go to Step 5.

STEP 5. Check of G and yaw rate sensor installation status

Check that the G and yaw rate sensor is installed correctly.

Q: Is the check result normal?

YES : After checking the G and yaw rate sensor, perform the calibration of the G and yaw rate sensor to make ASC-ECU relearn the neutral point.(Refer to [P.35C-287.](#)) Then go to Step 6.

NO : Reinstall the G and yaw rate sensor correctly. (Refer to [P.35C-304.](#)) Then go to Step 10.

STEP 6. Scan tool service data

Check the following service data. (Refer to [P.35C-276.](#))

- Item 08: Lateral G-sensor
- Item 12: Yaw rate sensor

Q: Is the check result normal?

YES : Go to Step 7.

NO : Replace the G and yaw rate sensor. (Refer to [P.35C-304.](#)) Then go to Step 10.

STEP 7. Check of steering wheel sensor installation status

Check that the steering wheel sensor is installed correctly.

Q: Is the check result normal?

YES : Go to Step 8.

NO : Install the steering wheel sensor correctly. (Refer to [P.35C-305.](#)) Then go to Step 8.

STEP 8. Wheel alignment check

Refer to [P.33-8.](#)

Q: Is the check result normal?

YES : After checking the wheel alignment, perform the calibration of steering wheel sensor to make ASC-ECU relearn the neutral point.(Refer to [P.35C-289.](#)) Then go to Step 9.

NO : After adjusting the wheel alignment, perform the calibration of steering wheel sensor to make ASC-ECU relearn the neutral point.(Refer to [P.35C-289.](#)) Then go to Step 9.

STEP 9. Scan tool service data

Check the following service data. (Refer to [P.35C-276.](#))

- Item 11: Steering angle sensor

Q: Is the check result normal?

YES : Go to Step 10.

NO : Replace the steering wheel sensor. (Refer to [P.35C-305.](#)) Then go to Step 10.

STEP 10. Check whether the DTC is reset.**Q: Is DTC C123C set?**

YES : Replace the hydraulic unit (incorporates in ASC-ECU).(Refer to [P.35C-298.](#)) Then go to Step 11.

NO : Intermittent malfunction. (Refer to GROUP 00 –How to Cope with Intermittent Malfunction [P.00-15.](#))

STEP 11. Check whether the DTC is reset.**Q: Is DTC C123C set?**

YES : Return to Step 1.

NO : The procedure is complete.

DTC C2204: Internal abnormality in G and yaw rate sensor

⚠ CAUTION

- If there is any problem in the CAN bus lines, an incorrect diagnostic trouble code may be set. Prior to this diagnosis, diagnose the CAN bus lines.
- Whenever the ECU is replaced, ensure that the CAN bus lines are normal.
- Do not drop the G and yaw rate sensor or subject it to a shock.
- When the G and yaw rate sensor is replaced, always perform the calibration to make ASC-ECU learn the neutral point. (Refer to [P.35C-287](#).)
- When the hydraulic unit (integrated with ASC-ECU) is replaced, always perform the calibration of steering wheel sensor, G and yaw rate sensor, brake fluid pressure sensor, cut valve, and inlet valve. (Refer to [P.35C-287](#), [P.35C-289](#), [P.35C-294](#), and [P.35C-295](#).)

CIRCUIT OPERATION

- ASC-ECU supplies power to the G and yaw rate sensor at the terminal No. 1.
- The G and yaw rate sensor outputs the signal to ASC-ECU via the local CAN bus lines.

DTC SET CONDITIONS

This diagnostic trouble code is set if any malfunction below is found:

- Abnormality is detected by the self-diagnosis of the G and yaw rate sensor.
- Output value of the G and yaw rate sensor is not within the standard value range.

NOTE: This diagnostic trouble code may be set when G and yaw rate sensor is put on the turntable turning at high speed.

PROBABLE CAUSES

- Improper installation of the G and yaw rate sensor
- Damaged wiring harness and connectors
- G and yaw rate sensor malfunction
- ASC-ECU malfunction

DIAGNOSIS**Required Special Tools:**

- MB991958 Scan Tool (M.U.T.-III Sub Assembly)
 - MB991824: Vehicle Communication Interface (V.C.I.)
 - MB991827 M.U.T.-III USB Cable
 - MB991910 M.U.T.-III Main Harness A

STEP 1. Using scan tool MB991958, diagnose the CAN bus lines.

Using scan tool MB991958, diagnose the CAN bus lines.

Q: Is the check result normal?

YES : Go to Step 2.

NO : Repair the CAN bus lines. (Refer to GROUP 54C – Troubleshooting [P.54C-15.](#)) After repairing the CAN bus line, go to Step 2.

STEP 2. Check for diagnostic trouble codes of other systems

Check if diagnostic trouble code No. U0125 is also set in ASC-ECU.

Q: Is DTC U0125 set?

YES : Perform troubleshooting for the diagnostic trouble code that is set. (Refer to [P.35C-212.](#)) Then go to Step 3.

NO : Go to Step 3.

STEP 3. Check whether the DTC is reset.**Q: Is DTC C2204 set?**

YES : Go to Step 4.

NO : The procedure is complete.

STEP 4. Scan tool service data

Check the following service data. (Refer to [P.35C-276.](#))

- Item 08: Lateral G sensor
- Item 09: G sensor
- Item 12: Yaw rate sensor
- Item 73: Lateral G sensor offset
- Item 97: Yaw rate sensor offset

Q: Is the check result normal?

YES : Go to Step 5.

NO : Replace the G and yaw rate sensor. (Refer to [P.35C-304.](#)) Then go to Step 5.

STEP 5. Check whether the DTC is reset.**Q: Is DTC C2204 set?**

YES : Replace the hydraulic unit (incorporates in ASC-ECU).(Refer to [P.35C-298.](#)) Then, go to Step 6.

NO : The procedure is complete.

STEP 6. Check whether the DTC is reset.**Q: Is DTC C2204 set?**

YES : Return to Step 1.

NO : The procedure is complete.

DTC C2111: Brake fluid pressure sensor power supply circuit (low input)**DTC C2112: Brake fluid pressure sensor power supply circuit (high input)**

⚠ CAUTION

- If there is any problem in the CAN bus lines, an incorrect diagnostic trouble code may be set. Prior to this diagnosis, diagnose the CAN bus lines.
- Whenever the ECU is replaced, ensure that the CAN bus lines are normal.
- When the hydraulic unit (integrated with ASC-ECU) is replaced, always perform the calibration of steering wheel sensor, G and yaw rate sensor, brake fluid pressure sensor, cut valve, and inlet valve.(Refer to [P.35C-287](#), [P.35C-289](#), [P.35C-294](#), and [P.35C-295](#).)

CIRCUIT OPERATION

When the brake pedal is depressed, the master cylinder pressure sensor integrated in the hydraulic unit detects the brake fluid pressure applied from the master cylinder. At the same time, it converts the pressure value into voltage signal, and outputs the signal.

DTC SET CONDITIONS

If the voltage supplied to the master cylinder pressure sensor is outside the standard value range, these diagnostic trouble codes are set.

PROBABLE CAUSES

ASC-ECU malfunction

DIAGNOSIS**Required Special Tools:**

- MB991958 Scan Tool (M.U.T.-III Sub Assembly)
 - MB991824: Vehicle Communication Interface (V.C.I.)
 - MB991827 M.U.T.-III USB Cable
 - MB991910 M.U.T.-III Main Harness A

STEP 1. Using scan tool MB991958, diagnose the CAN bus lines.

Using scan tool MB991958, diagnose the CAN bus lines.

Q: Is the check result normal?

YES : Go to Step 3.

NO : Repair the CAN bus lines. (Refer to GROUP 54C – Troubleshooting [P.54C-15](#).) After repairing the CAN bus line, go to Step 2.

STEP 2. DTC recheck after repairing the CAN bus line**Q: Is DTC C2111 or C2112 set?**

YES : Go to Step 3.

NO : This diagnosis is complete.

STEP 3. Battery check

Refer to GROUP 54A –Battery Test [P.54A-9](#).

Q: Is the battery in good condition?

YES : Go to Step 4.

NO : Charge or replace the battery.

STEP 4. Charging system check

Refer to GROUP 16 –Charging System [P.16-7](#).

Q: Is the charging system in good condition?

YES : Go to Step 5.

NO : Repair or replace the charging system component(s).

STEP 5. Check whether the DTC is reset.**Q: Is DTC C2111 or C2112 set?**

YES : Replace the hydraulic unit (incorporates in ASC-ECU).(Refer to [P.35C-298](#).) Then go to Step 6.

NO : Intermittent malfunction. (Refer to GROUP 00 –How to Cope with Intermittent Malfunction [P.00-15](#).)

STEP 6. Check whether the DTC is reset.**Q: Is DTC C2111 or C2112 set?**

YES : Return to Step 1.

NO : The procedure is complete.

DTC C2114: Abnormality in G and yaw rate sensor operation voltage (Low voltage)
DTC C2115: Abnormality in G and yaw rate sensor operation voltage (High voltage)

G and Yaw Rate Sensor Circuit

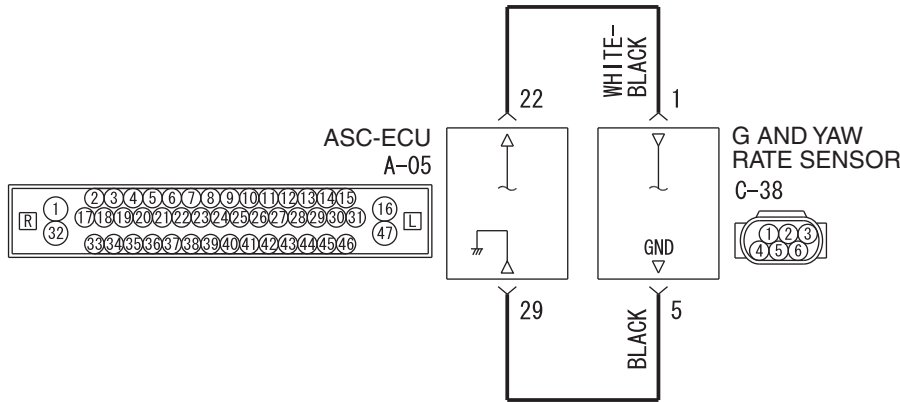

WAH35M010A

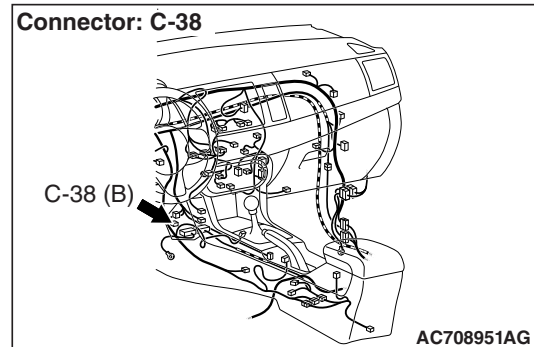
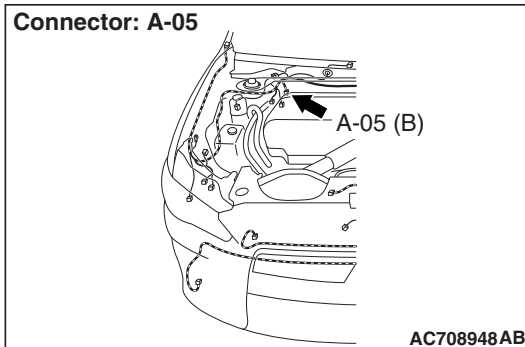

CAUTION

- If there is any problem in the CAN bus lines, an incorrect diagnostic trouble code may be set. Prior to this diagnosis, diagnose the CAN bus lines.
- Whenever the ECU is replaced, ensure that the CAN bus lines are normal.
- Do not drop the G and yaw rate sensor or subject it to a shock.
- When the G and yaw rate sensor is replaced, always perform the calibration to make ASC-ECU learn the neutral point. (Refer to [P.35C-287](#).)
- When the hydraulic unit (integrated with ASC-ECU) is replaced, always perform the calibration of steering wheel sensor, G and yaw rate sensor, brake fluid pressure sensor, cut valve, and inlet valve. (Refer to [P.35C-287](#), [P.35C-289](#), [P.35C-294](#), and [P.35C-295](#).)

CIRCUIT OPERATION

- ASC-ECU supplies power to the G and yaw rate sensor at the terminal No. 1.
- The G and yaw rate sensor outputs the signal to ASC-ECU via the local CAN bus lines.

DTC SET CONDITIONS

This diagnostic trouble code is set if any malfunction below is found:

DTC C2114

- When the power supply voltage applied from ASC-ECU to the G and yaw rate sensor is not within the standard value range (low)

DTC C2115

- When the power supply voltage applied from ASC-ECU to the G and yaw rate sensor is not within the standard value range (high)

PROBABLE CAUSES

- Damaged wiring harness and connectors
- G and yaw rate sensor malfunction
- ASC-ECU malfunction

DIAGNOSIS**Required Special Tools:**

- MB991958 Scan Tool (M.U.T.-III Sub Assembly)
 - MB991824: Vehicle Communication Interface (V.C.I.)
 - MB991827 M.U.T.-III USB Cable
 - MB991910 M.U.T.-III Main Harness A

STEP 1. Using scan tool MB991958, diagnose the CAN bus lines.

Using scan tool MB991958, diagnose the CAN bus lines.

Q: Is the check result normal?

YES : Go to Step 2.

NO : Repair the CAN bus lines. (Refer to GROUP 54C – CAN Bus Diagnostics table [P.54C-15](#)). On completion, go to Step 2.

STEP 2. Check for diagnostic trouble codes of other systems

Check if DTC U0125 is also set in ASC-ECU.

Q: Is DTC U0125 set?

YES : Perform troubleshooting for the diagnostic trouble code that is set. (Refer to [P.35C-212](#).) Then go to Step 3.

NO : Go to Step 3.

STEP 3. DTC recheck after repairing the CAN bus line

Q: Is DTC C2114 or C2115 set?

YES : Go to Step 4.

NO : The procedure is complete.

STEP 4. Scan tool service data

Check the following service data. (Refer to [P.35C-276.](#))

- Item 08: Lateral G sensor
- Item 09: G sensor
- Item 12: Yaw rate sensor

Q: Is the check result normal?

YES : Go to Step 12.

NO : Go to Step 5.

STEP 5. G and yaw rate sensor installation check

Check that the G and yaw rate sensor is installed correctly.

Q: Is the check result normal?

YES : Go to Step 6.

NO : Reinstall the G and yaw rate sensor correctly. (Refer to [P.35C-304.](#)) Then go to Step 13.

STEP 6. Connector check: A-05 ASC-ECU connector, C-38 G and yaw rate sensor connector

Q: Is the check result normal?

YES : Go to Step 7.

NO : Repair the defective connector.

STEP 7. Voltage measurement at C-38 G and yaw rate sensor connector

- (1) Disconnect the connector.
- (2) Turn the ignition switch to the ON position.
- (3) Measure the voltage between the terminal No.1 and the body ground.

OK: Battery positive voltage

Q: Is the check result normal?

YES : Go to Step 10.

NO : Go to Step 8.

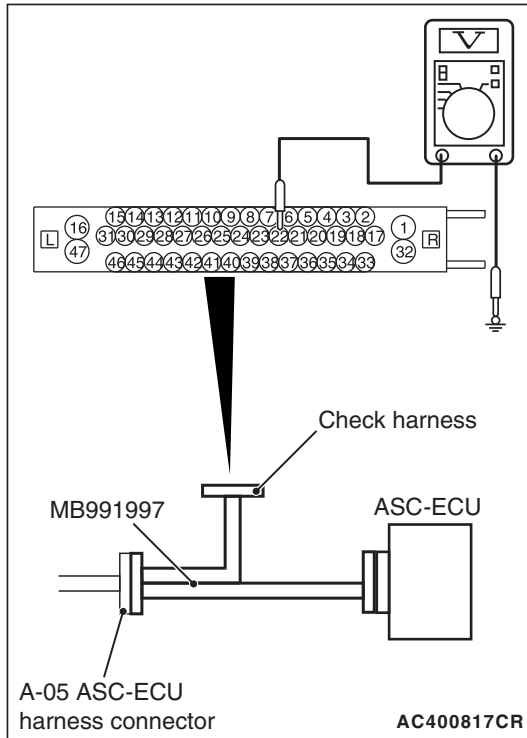
**STEP 8. Voltage measurement at A-05 ASC-ECU connector**

- (1) Disconnect the ASC-ECU connector, connect the special tool ASC check harness (MB991997) to the ASC-ECU-side connector and the wiring harness-side connector, and then measure at the special tool connector side.
- (2) Disconnect C-38 G and yaw rate sensor connector.
- (3) Turn the ignition switch to the ON position.
- (4) Measure the voltage between the terminal No.22 and the body ground.

OK: Battery positive voltage

Q: Is the check result normal?

YES : Repair the wiring harness between A-05 ASC-ECU connector terminal No. 22 and C-38 G and yaw rate sensor connector terminal No. 1.

NO : Go to Step 9.

STEP 9. Wiring harness check between A-05 ASC-ECU connector terminal No.22 and C-38 G and yaw rate sensor connector terminal No.1.

- Short circuit check of power supply circuit

Q: Is the check result normal?

YES : Go to Step 12.

NO : Repair the wiring harness between A-05 ASC-ECU connector terminal No. 22 and C-38 G and yaw rate sensor connector terminal No. 1.

STEP 10. Wiring harness check between A-05 ASC-ECU connector terminal No.29 and C-38 G and yaw rate sensor connector terminal No.5.

- Open circuit check of the ground circuit

Q: Is the check result normal?

YES : Replace the G and yaw rate sensor. (Refer to [P.35C-304.](#)) Then go to Step 11.

NO : Repair the wiring harness between A-05 ASC-ECU connector terminal No. 29 and C-38 G and yaw rate sensor connector terminal No. 5.

STEP 11. Check whether the DTC is reset.**Q: Is DTC C2114 or C2115 set?**

YES : Replace the hydraulic unit (incorporates in ASC-ECU). (Refer to [P.35C-298.](#)) Then go to Step 13.

NO : The procedure is complete.

STEP 12. Check whether the DTC is reset.

Q: Is DTC C2114 or C2115 set?

- YES :** Replace the hydraulic unit (incorporates in ASC-ECU).(Refer to [P.35C-298.](#)) Then go to Step 13.
- NO :** Intermittent malfunction. (Refer to GROUP 00 –How to Cope with Intermittent Malfunction [P.00-15.](#))

STEP 13. Check whether the DTC is reset.

Q: Is DTC C2114 or C2115 set?

- YES :** Return to Step 1.
- NO :** The procedure is complete.

DTC C123A: Abnormality in sensor calibration

 **CAUTION**

- If there is any problem in the CAN bus lines, an incorrect diagnostic trouble code may be set. Prior to this diagnosis, diagnose the CAN bus lines.
- Whenever the ECU is replaced, ensure that the CAN bus lines are normal.
- Do not drop the G and yaw rate sensor or subject it to a shock.
- When the G and yaw rate sensor is replaced, always perform the calibration to make ASC-ECU learn the neutral point. (Refer to [P.35C-287.](#))
- When the hydraulic unit (integrated with ASC-ECU) is replaced, always perform the calibration of steering wheel sensor, G and yaw rate sensor, brake fluid pressure sensor, cut valve, and inlet valve.(Refer to [P.35C-287](#), [P.35C-289](#), [P.35C-294](#), and [P.35C-295.](#))

CIRCUIT OPERATION

ASC-ECU stores the calibrated value of the G and yaw rate sensor, steering wheel sensor, and master cylinder pressure sensor.

DTC SET CONDITIONS

This diagnostic trouble code is set when the calibrated value for each sensor stored in ASC-ECU is abnormal.

- Abnormality of G and yaw rate sensor neutral position
- Abnormality of steering wheel sensor neutral position
- Abnormality of master cylinder pressure sensor neutral position

PROBABLE CAUSES

- Accidental shutdown of power supply during storing operation of calibrated value
- ASC-ECU malfunction
- External noise interference

DIAGNOSIS**Required Special Tools:**

- MB991958 Scan Tool (M.U.T.-III Sub Assembly)
 - MB991824: Vehicle Communication Interface (V.C.I.)
 - MB991827 M.U.T.-III USB Cable
 - MB991910 M.U.T.-III Main Harness A

STEP 1. Using scan tool MB991958, diagnose the CAN bus lines.

Using scan tool MB991958, diagnose the CAN bus lines.

Q: Is the check result normal?

YES : Go to Step 3.

NO : Repair the CAN bus lines. (Refer to GROUP 54C – Troubleshooting [P.54C-15.](#)) After repairing the CAN bus line, go to Step 2.

STEP 2. DTC recheck after repairing the CAN bus line**Q: Is DTC C123A set?**

YES : Go to Step 3.

NO : The procedure is complete.

STEP 3. Check for diagnostic trouble code is set.

Check if the diagnostic trouble code is set related to the G and yaw rate sensor, steering wheel sensor, and master cylinder pressure sensor.

Q: Is any DTC set?

YES : Carry out the diagnosis for the diagnostic trouble code that is set. (Refer to [P.35C-22.](#))

NO : Go to Step 4.

STEP 4. G and yaw rate sensor calibration

Perform calibration of the G and yaw rate sensor. (Refer to [P.35C-287.](#))

Q: Has the calibration succeeded?

YES : Go to Step 5.

NO : Replace the hydraulic unit (incorporates in ASC-ECU).(Refer to [P.35C-298.](#)) Then go to Step 8.

STEP 5. Steering wheel sensor calibration

Perform calibration of the steering wheel sensor. (Refer to [P.35C-289.](#))

Q: Has the calibration succeeded?

YES : Go to Step 6.

NO : Replace the hydraulic unit (incorporates in ASC-ECU).(Refer to [P.35C-298.](#)) Then go to Step 8.

STEP 6. Master cylinder pressure sensor calibration

Perform calibration of the brake fluid pressure sensor. (Refer to [P.35C-294](#).)

Q: Has the calibration succeeded?

YES : Go to Step 7.

NO : Replace the hydraulic unit (incorporates in ASC-ECU).(Refer to [P.35C-298](#).) Then go to Step 8.

STEP 7. Check whether the DTC is reset.

Q: Is DTC C123A set?

YES : Replace the hydraulic unit (incorporates in ASC-ECU).(Refer to [P.35C-298](#).) Then go to Step 8.

NO : Intermittent malfunction. (Refer to GROUP 00 –How to Cope with Intermittent Malfunction [P.00-15](#).)

STEP 8. Check whether the DTC is reset.

Q: Is DTC C123A set?

YES : Return to Step 1.

NO : The procedure is complete.

DTC C1219: Abnormality in steering wheel sensor signal

⚠ CAUTION

- If there is any problem in the CAN bus lines, an incorrect diagnostic trouble code may be set. Prior to this diagnosis, diagnose the CAN bus lines.
- Whenever the ECU is replaced, ensure that the CAN bus lines are normal.
- When the steering wheel sensor is replaced, always perform calibration to make ASC-ECU learn the neutral point. (Refer to [P.35C-289](#).)
- Do not drop the G and yaw rate sensor or subject it to a shock.
- When the G and yaw rate sensor is replaced, always perform the calibration to make ASC-ECU learn the neutral point. (Refer to [P.35C-287](#).)
- When the hydraulic unit (integrated with ASC-ECU) is replaced, after turning the ignition switch ON and OFF (vehicle information from ETACS-ECU is registered), always perform the calibration of steering wheel sensor, G and yaw rate sensor, brake fluid pressure sensor, cut valve, and inlet valve.(Refer to [P.35C-287](#), [P.35C-289](#), [P.35C-294](#), and [P.35C-295](#).)

CIRCUIT OPERATION

Steering wheel sensor outputs the signal to ASC-ECU via CAN bus lines.

DTC SET CONDITIONS

This diagnostic trouble code is set if any malfunction below is found:

- The tolerance of the neutral position of steering wheel sensor exceeds the specified range.
- Abnormality in steering wheel sensor output value
- Abnormality is detected by a comparison of output value from the steering wheel sensor with the output values from wheel speed sensor and G and yaw rate sensor.

PROBABLE CAUSES

- Improper installation of steering wheel sensor
- Wheel alignment not performed
- Steering wheel sensor malfunction
- Different steering wheel
- G and yaw rate sensor malfunction
- Wheel speed sensor malfunction
- ASC-ECU malfunction
- External noise interference

DIAGNOSIS**Required Special Tools:**

- MB991958 Scan Tool (M.U.T.-III Sub Assembly)
 - MB991824: Vehicle Communication Interface (V.C.I.)
 - MB991827 M.U.T.-III USB Cable
 - MB991910 M.U.T.-III Main Harness A

STEP 1. Using scan tool MB991958, diagnose the CAN bus lines.

Using scan tool MB991958, diagnose the CAN bus lines.

Q: Is the check result normal?

YES : Go to Step 3.

NO : Repair the CAN bus lines. (Refer to GROUP 54C – Troubleshooting [P.54C-15.](#)) After repairing the CAN bus line, go to Step 2.

STEP 2. DTC recheck after repairing the CAN bus line**Q: Is DTC C1219 set?**

YES : Go to Step 3.

NO : The procedure is complete.

STEP 3. Check the DTC.

Check if the wheel speed sensor-related, G and yaw rate sensor-related, or steering wheel sensor-related diagnostic trouble code is set.

Q: Is any DTC set?

YES : Troubleshoot the relevant diagnostic trouble code, and then go to Step 8.

NO : Go to Step 4.

STEP 4. Check of steering wheel sensor installation status

Check that the steering wheel sensor is installed correctly.
(Refer to [P.35C-305](#).)

Q: Is the check result normal?

YES : Go to Step 5.

NO : Install the steering wheel sensor correctly. (Refer to [P.35C-305](#).) Then go to Step 5.

STEP 5. Wheel alignment check

Q: Is the check result normal?

YES : After checking the wheel alignment, perform the calibration of steering wheel sensor to make ASC-ECU relearn the neutral point.(Refer to [P.35C-289](#).) Then go to Step 6.

NO : After adjusting the wheel alignment, perform the calibration of steering wheel sensor to make ASC-ECU relearn the neutral point.(Refer to [P.35C-289](#).) Then go to Step 6.

STEP 6. Scan tool service data

Check the following service data. (Refer to [P.35C-276](#).)

- Item 11: Steering angle sensor

Q: Is the check result normal?

YES : Go to Step 7.

NO : Replace the steering wheel sensor.(Refer to [P.35C-305](#).) Then go to Step 8.

STEP 7. Check whether the DTC is reset.

Q: Is DTC C1219 set?

YES : Replace the hydraulic unit (incorporates in ASC-ECU).(Refer to [P.35C-298](#).) Then go to Step 8.

NO : The procedure is complete.

STEP 8. Check whether the DTC is reset.

Q: Is DTC C1219 set?

YES : Return to Step 1.

NO : The procedure is complete.

DTC C121A: Abnormality in steering wheel sensor initialization

⚠ CAUTION

- If there is any problem in the CAN bus lines, an incorrect diagnostic trouble code may be set. Prior to this diagnosis, diagnose the CAN bus lines.
- Whenever the ECU is replaced, ensure that the CAN bus lines are normal.
- When the steering wheel sensor is replaced, always perform calibration to make ASC-ECU learn the neutral point. (Refer to [P.35C-289](#).)
- When the hydraulic unit (integrated with ASC-ECU) is replaced, after turning the ignition switch ON and OFF (vehicle information from ETACS-ECU is registered), always perform the calibration of steering wheel sensor, G and yaw rate sensor, brake fluid pressure sensor, cut valve, and inlet valve. (Refer to [P.35C-287](#), [P.35C-289](#), [P.35C-294](#), and [P.35C-295](#).)

CIRCUIT OPERATION

Steering wheel sensor stores the neutral position learned using scan tool MB991958. When the neutral position has not been learned, the steering wheel sensor outputs the signal indicating that the learning has not been performed.

DTC SET CONDITIONS

This diagnostic trouble code is set when it is detected that the steering wheel sensor has not learned the neutral position.

PROBABLE CAUSES

- Neutral position of steering wheel sensor not learned
- Steering wheel sensor malfunction
- ASC-ECU malfunction

DIAGNOSIS**Required Special Tools:**

- MB991958 Scan Tool (M.U.T.-III Sub Assembly)
 - MB991824: Vehicle Communication Interface (V.C.I.)
 - MB991827 M.U.T.-III USB Cable
 - MB991910 M.U.T.-III Main Harness A

STEP 1. Using scan tool MB991958, diagnose the CAN bus lines.

Using scan tool MB991958, diagnose the CAN bus lines.

Q: Is the check result normal?

YES : Go to Step 3.

NO : Repair the CAN bus lines. (Refer to GROUP 54C – Troubleshooting [P.54C-15](#).) After repairing the CAN bus line, go to Step 2.

STEP 2. DTC recheck after repairing the CAN bus line

Q: Is DTC C121A set?

YES : Go to Step 3.

NO : The procedure is complete.

STEP 3. Steering wheel sensor calibration

Perform calibration of the steering wheel sensor. (Refer to [P.35C-289.](#))

Q: Has the calibration succeeded?

YES : Go to Step 4.

NO : Replace the steering wheel sensor.(Refer to [P.35C-305.](#)) Then go to Step 4.

STEP 4. Check whether the DTC is reset.

Q: Is DTC C121A set?

YES : Replace the hydraulic unit (incorporates in ASC-ECU).(Refer to [P.35C-298.](#)) Then go to Step 5.

NO : The procedure is complete.

STEP 5. Check whether the DTC is reset.

Q: Is DTC C121A set?

YES : Return to Step 1.

NO : The procedure is complete.

DTC C2205: Internal malfunction of steering wheel sensor

⚠ CAUTION

- If there is any problem in the CAN bus lines, an incorrect diagnostic trouble code may be set. Prior to this diagnosis, diagnose the CAN bus lines.
- Whenever the ECU is replaced, ensure that the CAN bus lines are normal.
- When the steering wheel sensor is replaced, always perform calibration to make ASC-ECU learn the neutral point. (Refer to [P.35C-289.](#))
- When the hydraulic unit (integrated with ASC-ECU) is replaced, after turning the ignition switch ON and OFF (vehicle information from ETACS-ECU is registered), always perform the calibration of steering wheel sensor, G and yaw rate sensor, brake fluid pressure sensor, cut valve, and inlet valve.(Refer to [P.35C-287](#), [P.35C-289](#), [P.35C-294](#), and [P.35C-295.](#))

CIRCUIT OPERATION

Steering wheel sensor sends its status signal to ASC-ECU.

DTC SET CONDITIONS

This diagnostic trouble code is set when ASC-ECU detects that the steering wheel sensor has a malfunction.

PROBABLE CAUSES

- Steering wheel sensor malfunction
- ASC-ECU malfunction
- External noise interference

DIAGNOSIS**Required Special Tools:**

- MB991958 Scan Tool (M.U.T.-III Sub Assembly)
 - MB991824: Vehicle Communication Interface (V.C.I.)
 - MB991827 M.U.T.-III USB Cable
 - MB991910 M.U.T.-III Main Harness A

STEP 1. Using scan tool MB991958, diagnose the CAN bus lines.

Using scan tool MB991958, diagnose the CAN bus lines.

Q: Is the check result normal?

YES : Go to Step 2.

NO : Repair the CAN bus lines. (Refer to GROUP 54C – Troubleshooting [P.54C-15.](#)) After repairing the CAN bus line, go to Step 4.

STEP 2. Check whether the DTC is reset.**Q: Is DTC C2205 set?**

YES : Replace the steering wheel sensor.(Refer to [P.35C-305.](#)) Then go to Step 3.

NO : The procedure is complete.

STEP 3. Check whether the DTC is reset.**Q: Is DTC C2205 set?**

YES : Replace the hydraulic unit (incorporates in ASC-ECU).(Refer to [P.35C-298.](#)) Then go to Step 4.

NO : The procedure is complete.

STEP 4. Check whether the DTC is reset.**Q: Is DTC C2205 set?**

YES : Go to Step 1.

NO : The procedure is complete.

DTC C1608: Implausible diagnosis data

ASC-ECU Power Supply Circuit

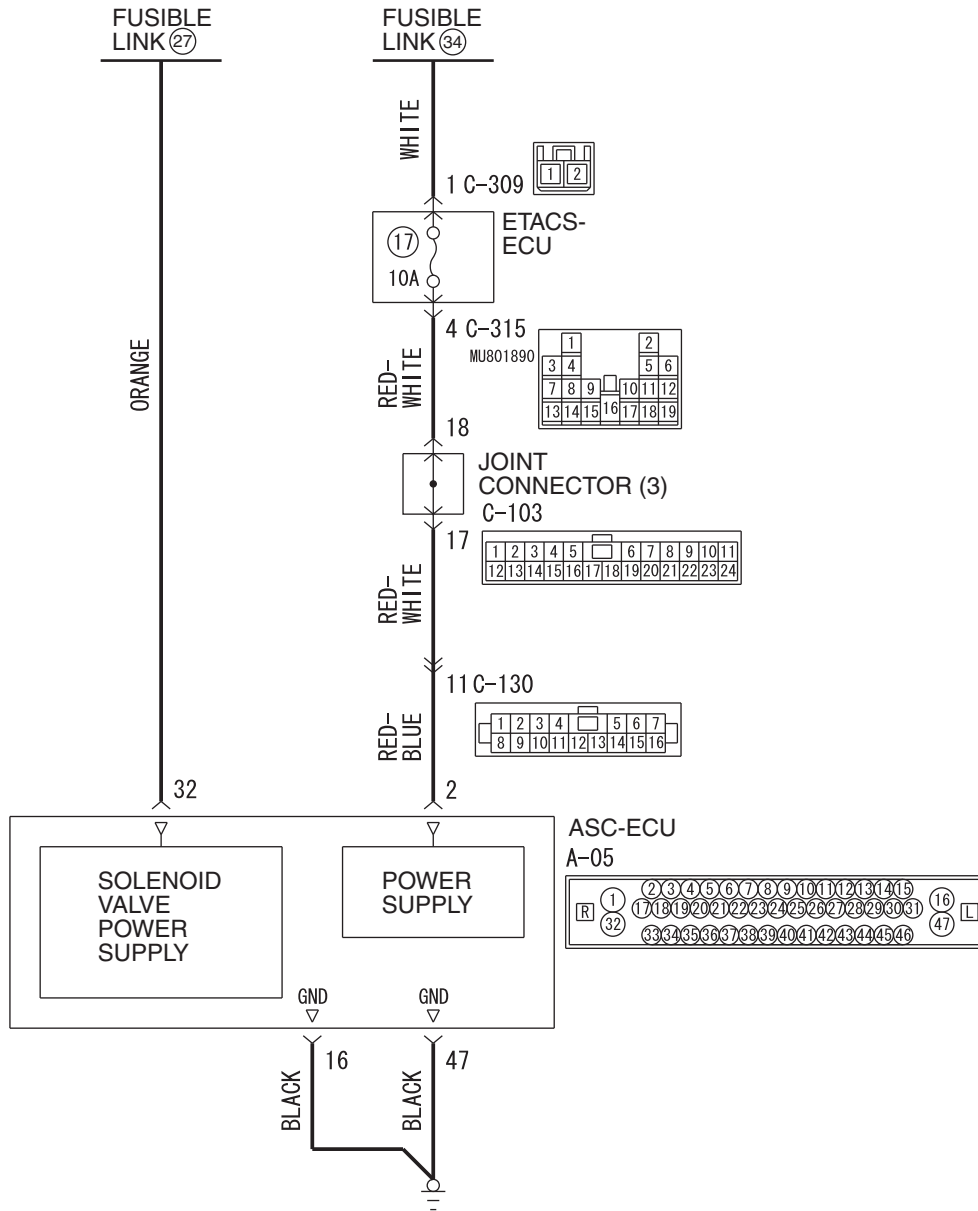

WAH35M011A

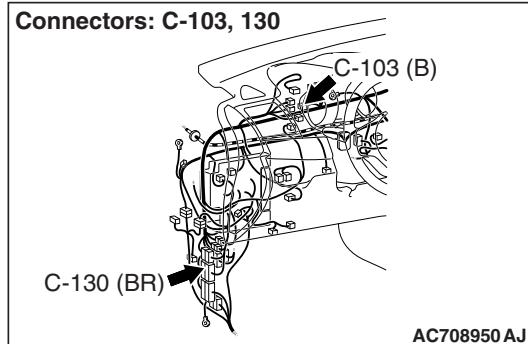
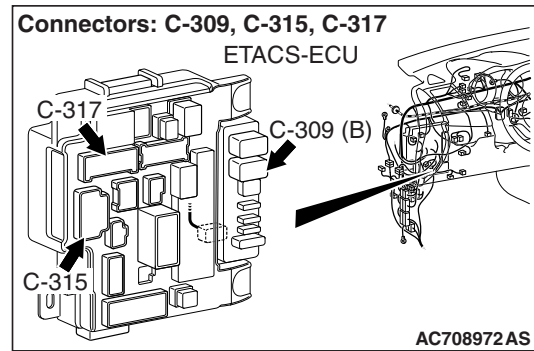
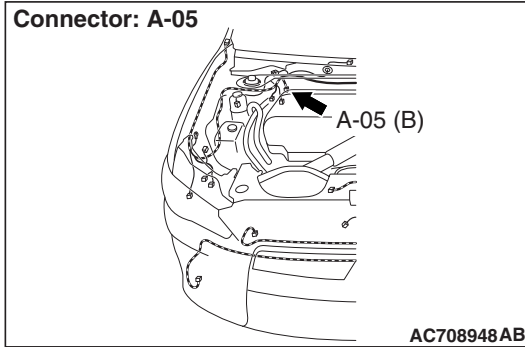

⚠ CAUTION

- If there is any problem in the CAN bus lines, an incorrect diagnostic trouble code may be set. Prior to this diagnosis, diagnose the CAN bus lines.
- Whenever the ECU is replaced, ensure that the CAN bus lines are normal.
- When the hydraulic unit (integrated with ASC-ECU) is replaced, after turning the ignition switch ON and OFF (vehicle information from ETACS-ECU is registered), always perform the calibration of steering wheel sensor, G and yaw rate sensor, brake fluid pressure sensor, cut valve, and inlet valve. (Refer to [P.35C-287](#), [P.35C-289](#), [P.35C-294](#), and [P.35C-295](#).)
- When the ASC-ECU connector or battery terminal is disconnected with the ignition switch ON, this diagnostic trouble code may be set.
- When this diagnostic trouble code is set, no other failure information will be set.

CIRCUIT OPERATION

- The ASC-ECU stores diagnostic trouble codes and failure information in the EEPROM*.
- ASC-ECU (EEPROM*) contains the power supply circuit (terminal No.2).

NOTE: *EEPROM (Electrical Erasable and Programmable ROM)

DTC SET CONDITIONS

This diagnostic trouble code is set under the cases below.

- Trouble information stored in the EEPROM is not reliable.
- ASC-ECU power supply is shut down while the trouble information is being written to EEPROM.

PROBABLE CAUSES

- Disconnection of the ASC-ECU connector or the battery terminal when the ignition switch is ON
- Loose battery terminal
- Abnormality in battery
- Damaged wiring harness and connectors
- ASC-ECU malfunction

DIAGNOSIS

Required Special Tools:

- MB991958 Scan Tool (M.U.T.-III Sub Assembly)
 - MB991824: Vehicle Communication Interface (V.C.I.)
 - MB991827 M.U.T.-III USB Cable
 - MB991910 M.U.T.-III Main Harness A
- MB991997: ASC check harness

STEP 1. Using scan tool MB991958, diagnose the CAN bus lines.

Using scan tool MB991958, diagnose the CAN bus lines.

Q: Is the check result normal?

YES : Go to Step 3.

NO : Repair the CAN bus lines. (Refer to GROUP 54C – Troubleshooting P.54C-15.) After repairing the CAN bus line, go to Step 2.

STEP 2. DTC recheck after repairing the CAN bus line

Q: Is DTC C1608 set?

YES : Go to Step 3.

NO : This diagnosis is complete.

STEP 3. Battery check

Refer to GROUP 54A –Battery Test P.54A-9.

Q: Is the battery in good condition?

YES : Go to Step 5.

NO : Go to Step 4.

STEP 4. Charging system check

Refer to GROUP 16 –Output Current Test P.16-8.

Q: Is the charging system in good condition?

YES : Replace the battery. Then go to Step 15.

NO : Repair or replace the charging system component(s), and then go to Step 15.

STEP 5. Connector check: A-05 ASC-ECU connector, C-103 joint connector, C-130 intermediate connector, C-309 ETACS-ECU connector, C-315 ETACS-ECU connector

Q: Is the check result normal?

YES : Go to Step 6.

NO : Repair the defective connector, and then go to Step 15.

STEP 6. Check of fusible link No. 27

Visually check for open circuit in the fusible link No. 27.

Q: Is the check result normal?

YES : Go to Step 8.

NO : Go to Step 7.

STEP 7. Resistance measurement at A-05 ASC-ECU connector

(1) Disconnect the connector, connect the special tool ASC check harness (MB991997) to the wiring harness-side connector, and measure the voltage at the special tool connector side.

NOTE: Do not connect the special tool to ASC-ECU.

(2) Measure the resistance between the terminal No.32 and the body ground.

OK: No continuity

Q: Is the check result normal?

YES : Replace the fusible link No.27, and then go to Step 15.

NO : An short circuit may be present in the power supply circuit. Repair the wiring harness between A-05 ASC-ECU connector terminal No.32 and the fusible link No.27. Replace the fusible link No.27, and then go to Step 15.

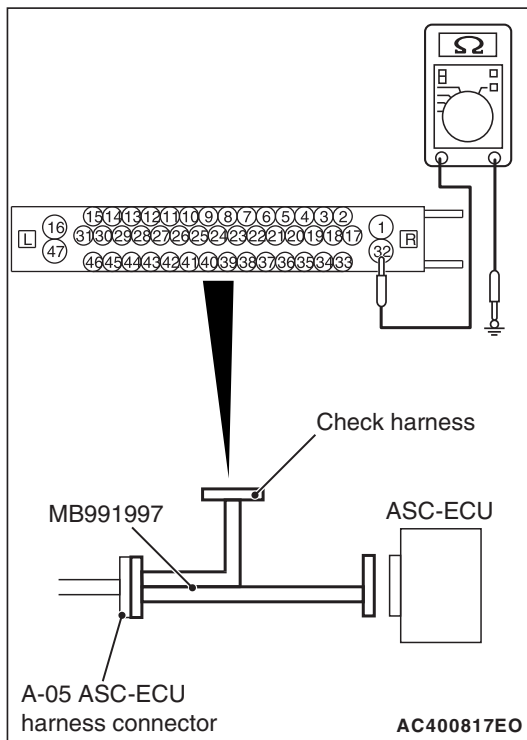

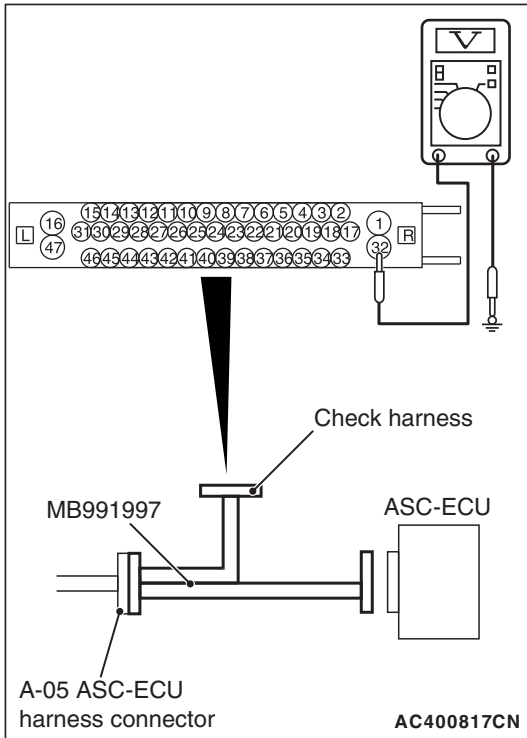

STEP 8. Voltage measurement at A-05 ASC-ECU connector

- (1) Disconnect the connector, connect the special tool ASC check harness (MB991997) to the wiring harness-side connector, and measure the voltage at the special tool connector side.

NOTE: Do not connect the special tool to ASC-ECU.

- (2) Measure the voltage between the terminal No.32 and the body ground.

OK: Battery positive voltage

Q: Is the check result normal?

YES : Go to Step 9.

NO : An open circuit may be present in the power supply circuit. Repair the wiring harness between A-05 ASC-ECU connector terminal No.32 and the fusible link No.27, and then go to Step 15.

STEP 9. Check of fusible link No.34

Visually check for open circuit in the fusible link No.34.

Q: Is the check result normal?

YES : Go to Step 11.

NO : Go to Step 10.

STEP 10. Resistance measurement at C-309 ETACS-ECU connector

- (1) Disconnect the connector, and measure the resistance at the harness connector side.
- (2) Measure the resistance between the terminal No.1 and the body ground.

OK: No continuity

Q: Is the check result normal?

YES : Replace the fusible link No.34, and then go to Step 15.

NO : An short circuit may be present in the power supply circuit. Repair the wiring harness between C-309 ETACS-ECU connector terminal No.1 and the fusible link No.34. Replace the fusible link No.34, and then go to Step 15.

STEP 11. Check of fuse No.17

Visually check for open circuit in the fuse No.17.

Q: Is the check result normal?

YES : Go to Step 13.

NO : Go to Step 12.

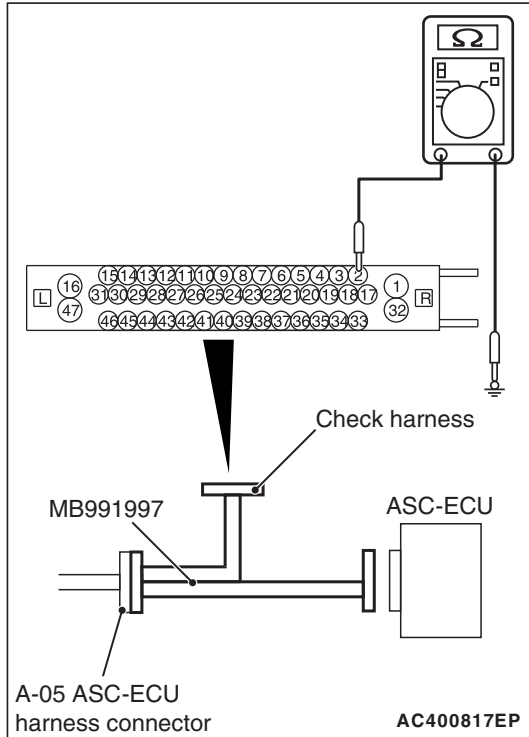

STEP 12. Resistance measurement at A-05 ASC-ECU connector

- (1) Disconnect the connector, connect the special tool ASC check harness (MB991997) to the wiring harness-side connector, and measure the voltage at the special tool connector side.

NOTE: Do not connect the special tool to ASC-ECU.

- (2) Remove fuse No.17.
- (3) Measure the resistance between the terminal No.2 and the body ground.

OK:No continuity

Q: Is the check result normal?

YES : Replace the fuse No.17, and then go to Step 15.

NO : An short circuit may be present in the power supply circuit. Repair the wiring harness between C-315 ETACS-ECU connector terminal No.4 and the A-05 ASC-ECU connector terminal No.2. Replace the fuse No.17, and then go to Step 15.

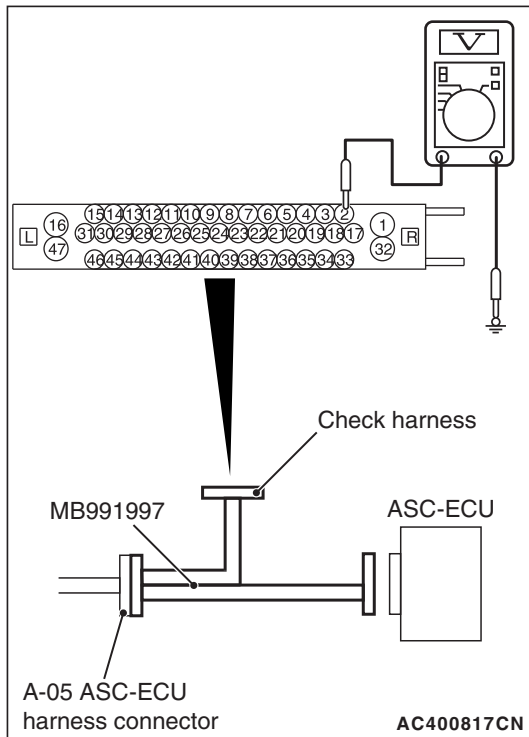

STEP 13. Voltage measurement at the A-05 ASC-ECU connector

- (1) Disconnect the connector, connect the special tool ASC check harness (MB991997) to the wiring harness-side connector, and measure the voltage at the special tool connector side.

NOTE: Do not connect the special tool to ASC-ECU.

- (2) Measure the voltage between the terminal No.2 and the body ground.

OK: Battery positive voltage

Q: Is the check result normal?

YES : Go to Step 14.

NO : An open circuit may be present in the power supply circuit. Repair the wiring harness between A-05 ASC-ECU connector terminal No.2 and the fusible link No.34, and then go to Step 15.

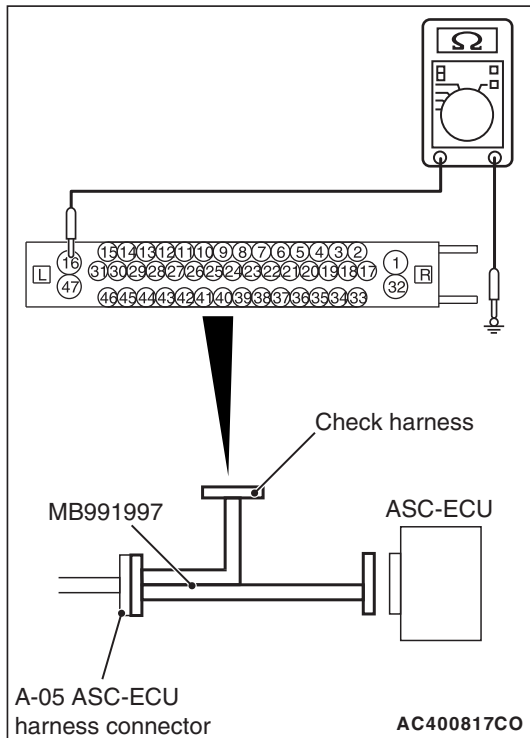

STEP 14. Resistance measurement at A-05 ASC-ECU connector

- (1) Disconnect the connector, connect the special tool ASC check harness (MB991997) to the wiring harness-side connector, and measure the voltage at the special tool connector side.

NOTE: Do not connect the special tool to ASC-ECU.

- (2) Measure the resistance between the terminal No.16 and the body ground, and between the terminal No.47 and the body ground

OK: Continuity exists (2 Ω or less)

Q: Is the check result normal?

YES : Go to Step 15.

NO : An open circuit may be present in the ground circuit. Repair the wiring harness between A-05 ASC-ECU connector terminal No. 16 and the body ground as well as between A-05 ASC-ECU connector terminal No. 47 and the body ground, and then go to Step 15.

STEP 15. Check whether the DTC is reset.

- (1) Erase the diagnostic trouble code.
- (2) Turn the ignition switch to the "LOCK" (OFF) position.
- (3) Turn the ignition switch to the "ON" position.
- (4) Perform a test run of the vehicle at the vehicle speed of 12 mph (20 km/h) or more. Then, check if the diagnostic trouble code is set in ASC-ECU.

Q: Is the DTC set?

YES (DTC C1608 is set) : Replace the hydraulic unit (integrated with ASC-ECU). (Refer to P.35C-298.)

YES (DTC other than C1608 is set) : Carry out the applicable troubleshooting for the DTC.

NO : This diagnosis is complete.

DTC C2002: Abnormality in valve calibration

⚠ CAUTION

- If there is any problem in the CAN bus lines, an incorrect diagnostic trouble code may be set. Prior to this diagnosis, diagnose the CAN bus lines.
- Whenever the ECU is replaced, ensure that the CAN bus lines are normal.
- During the calibrations of cut valve and inlet valve, do not depress the brake pedal or subject the vehicle to a vibration.
- When the hydraulic unit (integrated with ASC-ECU) is replaced, always perform the calibration of steering wheel sensor, G and yaw rate sensor, brake fluid pressure sensor, cut valve, and inlet valve. (Refer to [P.35C-287](#), [P.35C-289](#), [P.35C-294](#), and [P.35C-295](#).)

CIRCUIT OPERATION

ASC-ECU stores the correction values of cut valve and inlet valve in the EEPROM.

DTC SET CONDITIONS

This diagnostic trouble code is set when the calibration of the cut valve or inlet valve has not been performed, or when the correction value of cut valve or inlet valve is abnormal.

PROBABLE CAUSES

- ASC-ECU malfunction
- Noise interference

DIAGNOSIS**Required Special Tools:**

- MB991958 Scan Tool (M.U.T.-III Sub Assembly)
 - MB991824: Vehicle Communication Interface (V.C.I.)
 - MB991827 M.U.T.-III USB Cable
 - MB991910 M.U.T.-III Main Harness A

STEP 1. Using scan tool MB991958, diagnose the CAN bus lines.

Using scan tool MB991958, diagnose the CAN bus lines.

Q: Is the check result normal?

YES : Go to Step 2.

NO : Repair the CAN bus lines. (Refer to GROUP 54C – Troubleshooting [P.54C-15](#).) After repairing the CAN bus line, go to Step 2.

STEP 2. DTC recheck after repairing the CAN bus line**Q: Is DTC C2002 set?**

YES : Go to Step 3.

NO : This diagnosis is complete.

STEP 3. Check for diagnostic trouble codes

Check if any diagnostic trouble code other than No. C2002 is set in ASC-ECU.

Q: Is the check result normal?

YES : Carry out the diagnosis for the diagnostic trouble code that is set.(Refer to [P.35C-22.](#)) Then go to Step 4.

NO : Go to Step 4.

STEP 4. Cut valve and inlet valve calibration

Refer to [P.35C-295.](#)

Q: Is the calibration performed normally?

YES : Go to Step 7.

NO : Go to Step 5.

STEP 5. Service data check

Check the following service data. (Refer to [P.35C-276.](#))

- Item No. 14: Brake switch

Q: Is the check result normal?

YES : Go to Step 6.

NO : Check the stoplight switch. (Refer to GROUP 35A – Stoplight Switch Check [P.35A-25.](#))

STEP 6. Cut valve and inlet valve calibration

Refer to [P.35C-295.](#)

Q: Is the calibration performed normally?

YES : Go to Step 7.

NO : Replace the hydraulic unit (integrated with ASC-ECU).(Refer to [P.35C-298.](#)) Then, return to Step 1.

STEP 7. Check whether the DTC is reset.

Q: Is DTC C2002 set?

YES : Return to Step 1.

NO : This diagnosis is complete.

DTC U0001: Bus-off

⚠ CAUTION

- If there is any problem in the CAN bus lines, an incorrect diagnostic trouble code may be set. Prior to this diagnosis, diagnose the CAN bus lines.
- If diagnostic trouble code U0001 is set in ASC-ECU, always diagnose CAN bus lines. If there is any fault in the CAN bus lines, an incorrect DTC may be set.
- Whenever the ECU is replaced, ensure that the CAN bus lines are normal.
- When the hydraulic unit (integrated with ASC-ECU) is replaced, after turning the ignition switch ON and OFF (vehicle information from ETACS-ECU is registered), always perform the calibration of steering wheel sensor, G and yaw rate sensor, brake fluid pressure sensor, cut valve, and inlet valve.(Refer to [P.35C-287](#), [P.35C-289](#), [P.35C-294](#), and [P.35C-295](#).)

DTC SET CONDITIONS

This diagnostic trouble code is set when ASC-ECU has ceased CAN communication (bus off).

PROBABLE CAUSES

- Wiring harness or connector failure of CAN bus line
- ASC-ECU malfunction
- ECU malfunction of other system

DIAGNOSIS**Required Special Tools:**

- MB991958 Scan Tool (M.U.T.-III Sub Assembly)
 - MB991824: Vehicle Communication Interface (V.C.I.)
 - MB991827 M.U.T.-III USB Cable
 - MB991910 M.U.T.-III Main Harness A

STEP 1. Using scan tool MB991958, diagnose the CAN bus lines.

Using scan tool MB991958, diagnose the CAN bus lines.

Q: Is the check result normal?

YES : Go to Step 2.

NO : Repair the CAN bus lines. (Refer to GROUP 54C – Troubleshooting [P.54C-15](#).) After repairing the CAN bus line, go to Step 3.

STEP 2. Check whether the DTC is reset.**Q: Is DTC U0001 set?**

YES : Replace the hydraulic unit (incorporates in ASC-ECU).(Refer to [P.35C-298](#).) Then go to Step 3.

NO : Intermittent malfunction. (Refer to GROUP 00 –How to Cope with Intermittent Malfunction [P.00-15](#).)

STEP 3. Check whether the DTC is reset.

Q: Is DTC U0001 set?

YES : Return to Step 1.

NO : The procedure is complete.

DTC U0100: Engine time-out error
DTC U0101: TC-SST time-out error
DTC U0126: Steering wheel sensor time-out error
DTC U0141: ETACS time-out error
DTC U0136: AWC time-out error

⚠ CAUTION

- If there is any problem in the CAN bus lines, an incorrect diagnostic trouble code may be set. Prior to this diagnosis, diagnose the CAN bus lines.
- If diagnostic trouble codes U0100, U0101, U0126, U0141, and U0136 are set in ASC-ECU, always diagnose CAN bus lines. If there is any fault in the CAN bus lines, an incorrect DTC may be set.
- Whenever the ECU is replaced, ensure that the CAN bus lines are normal.
- When the steering wheel sensor is replaced, always perform calibration to make ASC-ECU learn the neutral point. (Refer to [P.35C-289](#).)
- When the hydraulic unit (integrated with ASC-ECU) is replaced, after turning the ignition switch ON and OFF (vehicle information from ETACS-ECU is registered), always perform the calibration of steering wheel sensor, G and yaw rate sensor, brake fluid pressure sensor, cut valve, and inlet valve. (Refer to [P.35C-287](#), [P.35C-289](#), [P.35C-294](#), and [P.35C-295](#).)

CIRCUIT OPERATION

ASC-ECU communicates with the engine control module, TC-SST-ECU, steering wheel sensor, ETACS-ECU, and AWC-ECU via the CAN bus lines.

DTC SET CONDITIONS

The diagnostic trouble code is stored if ASC-ECU cannot receive the signal sent from other ECU for a specified period.

PROBABLE CAUSES**DTC U0100**

- Wiring harness or connector failure of CAN bus line
- Engine ECU malfunction
- ASC-ECU malfunction

DTC U0101

- Wiring harness or connector failure of CAN bus line
- Malfunction of TC-SST-ECU
- ASC-ECU malfunction
- Interchanging of ETACS-ECU

DTC U0126

- Damaged wiring harness or connector in CAN bus line
- Malfunction of steering wheel sensor
- Malfunction of ASC-ECU

DTC U0141

- Wiring harness or connector failure of CAN bus line
- Malfunction of ETACS-ECU
- ASC-ECU malfunction

DTC U0136

- Wiring harness or connector failure of CAN bus line
- AWC-ECU malfunction
- ASC-ECU malfunction

DIAGNOSIS**Required Special Tools:**

- MB991958 Scan Tool (M.U.T.-III Sub Assembly)
 - MB991824: Vehicle Communication Interface (V.C.I.)
 - MB991827 M.U.T.-III USB Cable
 - MB991910 M.U.T.-III Main Harness A

STEP 1. Using scan tool MB991958, diagnose the CAN bus lines.

Using scan tool MB991958, diagnose the CAN bus lines.

Q: Is the check result normal?

YES : Go to Step 2.

NO : Repair the CAN bus lines. (Refer to GROUP 54C – Troubleshooting P.54C-15.) After repairing the CAN bus line, go to Step 5.

STEP 2. Scan tool diagnostic trouble code for other systems

Using scan tool MB991958, check if any other diagnostic trouble code is set in the ECU corresponding to the relevant diagnosis.

Q: Is other DTC set?

YES : Perform troubleshooting for the diagnostic trouble code that is set.

NO : Go to Step 3.

STEP 3. Using scan tool MB991958, check read the DTC other system.

Use scan tool to check if the same DTC (time-out) is set in the other ECU (CAN-C).

Q: Is any DTC set?

YES (DTC U0100 is set) : Replace the engine control module (ECM), and then go to Step 4.

YES (DTC U0101 is set) : Replace the TC-SST-ECU, and then go to Step 4.

YES (DTC U0126 is set) : Replace steering wheel sensor, and then go to Step 4.

YES (DTC U0141 is set) : Replace the ETACS-ECU, and then go to Step 4.

YES (DTC U0136 is set) : Replace the AWC-ECU, and then go to Step 4.

NO (No DTC is set.) : The procedure is complete.

STEP 4. Check whether the DTC is reset.

Q: Is DTC U0100, U0101, U0126, U0141 or U0136 set?

YES : Replace the hydraulic unit (incorporates in ASC-ECU).(Refer to [P.35C-298.](#)) Then go to Step 5.

NO : Intermittent malfunction. (Refer to GROUP 00 –How to Cope with Intermittent Malfunction [P.00-15.](#))

STEP 5. Check whether the DTC is reset.

Q: Is DTC U0100, U0101, U0126, U0141 or U0136 set?

YES : Return to Step 1.

NO : The procedure is complete.

DTC U0125: G and yaw rate sensor message time-out error/message error

G and Yaw Rate Sensor Circuit

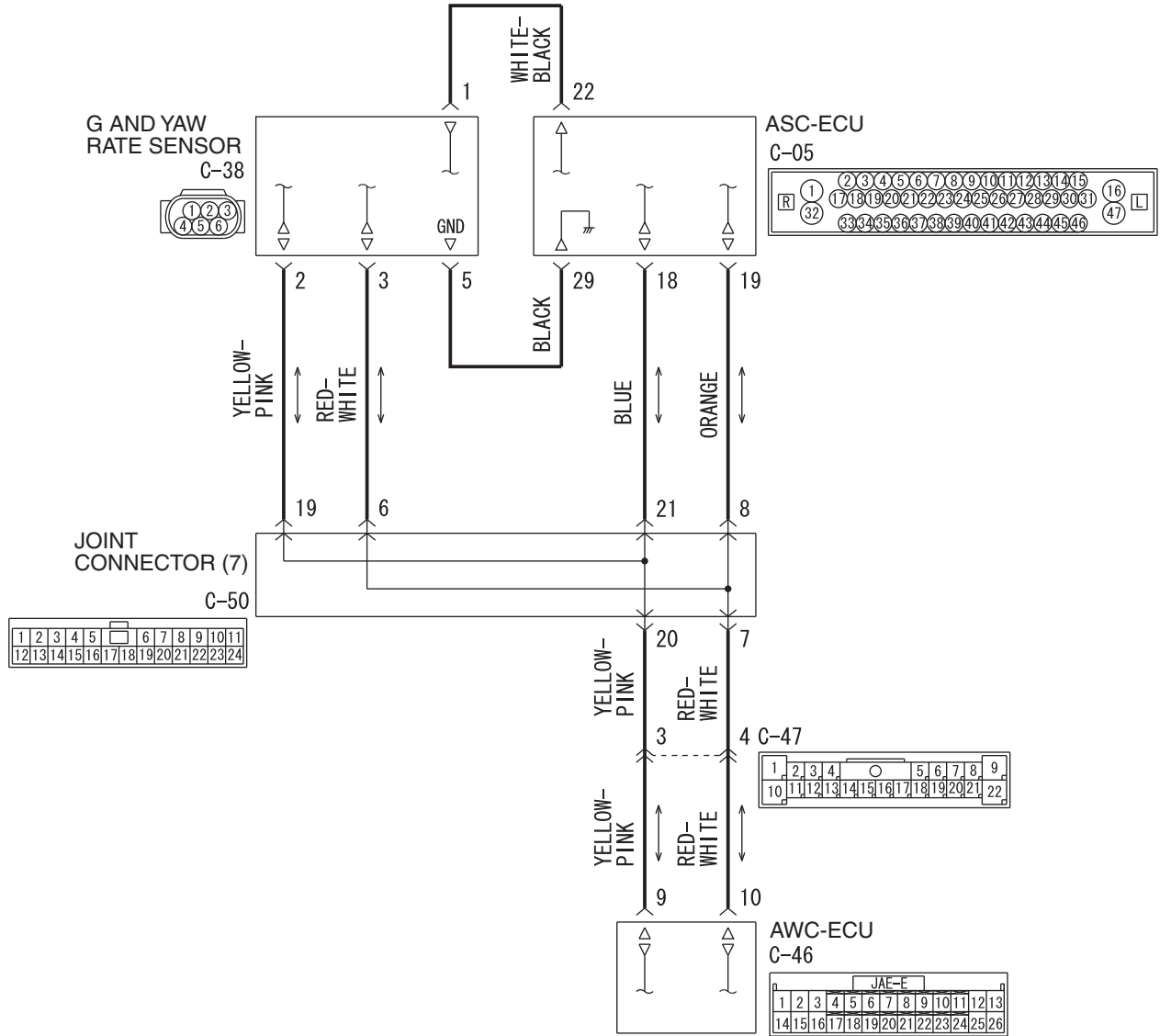

WAH35M012A

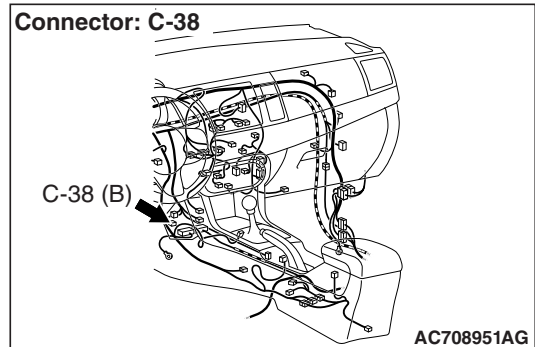
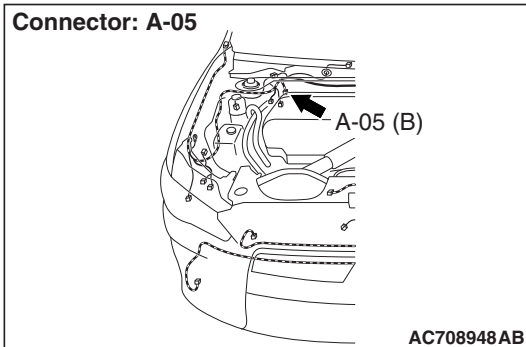

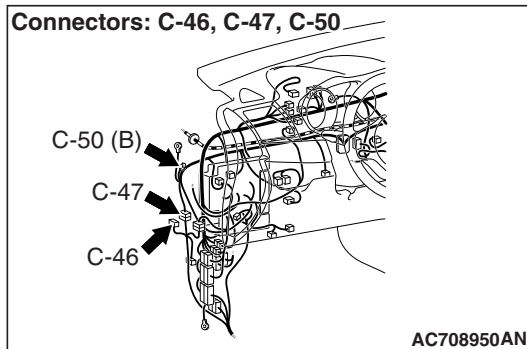

⚠ CAUTION

- If there is any problem in the CAN bus lines, an incorrect diagnostic trouble code may be set. Prior to this diagnosis, diagnose the CAN bus lines.
- Whenever the ECU is replaced, ensure that the CAN bus lines are normal.
- Do not drop the G and yaw rate sensor or subject it to a shock.
- When the G and yaw rate sensor is replaced, always perform the calibration to make ASC-ECU learn the neutral point. (Refer to [P.35C-287](#).)
- When the hydraulic unit (integrated with ASC-ECU) is replaced, after turning the ignition switch ON and OFF (vehicle information from ETACS-ECU is registered), always perform the calibration of steering wheel sensor, G and yaw rate sensor, brake fluid pressure sensor, cut valve, and inlet valve. (Refer to [P.35C-287](#), [P.35C-289](#), [P.35C-294](#), and [P.35C-295](#).)

CIRCUIT OPERATION

The G and yaw rate sensor outputs the signal to ASC-ECU and AWC-ECU via the special CAN bus lines (Local CAN).

DTC SET CONDITIONS

This diagnostic trouble code is set if ASC-ECU cannot receive the signal sent from the G and yaw rate sensor even when the voltage supplied to ASC-ECU is normal.

PROBABLE CAUSES

- Wiring harness or connector failure in special CAN bus lines (Local CAN) between ASC-ECU and G and yaw rate sensor.
- G and yaw rate sensor malfunction
- ASC-ECU malfunction
- External noise interference

DIAGNOSIS**Required Special Tools:**

- MB991958 Scan Tool (M.U.T.-III Sub Assembly)
 - MB991824: Vehicle Communication Interface (V.C.I.)
 - MB991827 M.U.T.-III USB Cable
 - MB991910 M.U.T.-III Main Harness A

STEP 1. Using scan tool MB991958, diagnose the CAN bus lines.

Using scan tool MB991958, diagnose the CAN bus lines.

Q: Is the check result normal?

YES : Go to Step 2.

NO : Repair the CAN bus lines. (Refer to GROUP 54C – Troubleshooting [P.54C-15](#).) After repairing the CAN bus line, go to Step 3.

STEP 2. Check for diagnostic trouble codes

Check if diagnostic trouble code No. U0251, U0440, and U0435 are simultaneously set in ASC-ECU.

Q: Are DTCs U0251, U0440 or U0435 set?

YES : Perform troubleshooting for the diagnostic trouble code that is set. (Refer to [P.35C-219](#).)

NO : Go to Step 3.

STEP 3. DTC recheck after repairing the CAN bus line**Q: Is DTC U0125 set?**

YES : Go to Step 4.

NO : This diagnosis is complete.

STEP 4. Connector check: A-05 ASC-ECU connector, C-46 AWC-ECU connector, C-47 intermediate connector, C-50 joint connector**Q: Is the check result normal?**

YES : Go to Step 5.

NO : Repair the connector, and then go to Step 8.

STEP 5. Wiring harness check between A-05 ASC-ECU connector terminal No. 18 and C-38 G and yaw rate sensor connector terminal No. 2, between A-05 ASC-ECU connector terminal No. 19 and C-38 G and yaw rate sensor connector terminal No. 3, between C-46 AWC-ECU connector terminal No. 9 and C-38 G and yaw rate sensor connector terminal No. 2, between C-46 AWC-ECU connector terminal No. 10 and C-38 G and yaw rate sensor connector terminal No. 3

- Open or short circuit check of communication circuit

Q: Is the check result normal?

YES : Go to Step 6.

NO : Repair the wiring harness, and then go to Step 8.

STEP 6. Check whether the DTC is reset.

Q: Is DTC U0125 set?

YES : Replace the G and yaw rate sensor. (Refer to [P.35C-304.](#)) Then go to Step 7.

NO : Intermittent malfunction. (Refer to GROUP 00 –How to Cope with Intermittent Malfunction [P.00-15.](#))

STEP 7. Check whether the DTC is reset.

Q: Is DTC U0125 set?

YES : Replace the hydraulic unit (incorporates in ASC-ECU). (Refer to [P.35C-298.](#)) Then go to Step 8.

NO : The procedure is complete.

STEP 8. Check whether the DTC is reset.

Q: Is DTC U0125 set?

YES : Return to Step 1.

NO : The procedure is complete.

DTC U0401: Engine malfunction detected

⚠ CAUTION

- If there is any problem in the CAN bus lines, an incorrect diagnostic trouble code may be set. Prior to this diagnosis, diagnose the CAN bus lines.
- Whenever the ECU is replaced, ensure that the CAN bus lines are normal.
- If diagnostic trouble code U0401 is set in ASC-ECU, always diagnose CAN bus lines. If there is any fault in the CAN bus lines, an incorrect DTC may be set.
- When the hydraulic unit (integrated with ASC-ECU) is replaced, after turning the ignition switch ON and OFF (vehicle information from ETACS-ECU is registered), always perform the calibration of steering wheel sensor, G and yaw rate sensor, brake fluid pressure sensor, cut valve, and inlet valve. (Refer to [P.35C-287](#), [P.35C-289](#), [P.35C-294](#), and [P.35C-295.](#))

CIRCUIT OPERATION

Engine-related signals are sent or received to and from between ASC-ECU and ECM via CAN bus lines.

DTC SET CONDITIONS

This diagnostic trouble code is set when the ECM malfunction has been detected.

PROBABLE CAUSES

- Malfunction of engine system
- ECM malfunction
- ASC-ECU malfunction
- External noise interference

DIAGNOSIS**Required Special Tools:**

- MB991958 Scan Tool (M.U.T.-III Sub Assembly)
 - MB991824: Vehicle Communication Interface (V.C.I.)
 - MB991827 M.U.T.-III USB Cable
 - MB991910 M.U.T.-III Main Harness A

STEP 1. Using scan tool MB991958, diagnose the CAN bus lines.

Using scan tool MB991958, diagnose the CAN bus lines.

Q: Is the check result normal?

YES : Go to Step 2.

NO : Repair the CAN bus lines. (Refer to GROUP 54C – Troubleshooting [P.54C-15.](#)) After repairing the CAN bus line, go to Step 5.

STEP 2. Scan tool diagnostic trouble code

Using scan tool MB991958, check if any diagnostic trouble code other than code No. U0401 is set in ASC-ECU.

Q: Is any DTC set?

YES : Troubleshoot the relevant diagnostic trouble code, and then go to Step 5.

NO : Go to Step 3.

STEP 3. Diagnostic trouble code check of other system using scan tool MB991958

Using scan tool MB991958, check if a diagnostic trouble code is set in the engine control module.

Q: Is any DTC set?

YES : Troubleshoot the relevant diagnostic trouble code, and then go to Step 5.

NO : Go to Step 4.

STEP 4. Check whether the DTC is reset.**Q: Is DTC U0401 set?**

YES : Replace the hydraulic unit (incorporates in ASC-ECU).(Refer to [P.35C-298.](#)) Then go to Step 5.

NO : Intermittent malfunction. (Refer to GROUP 00 –How to Cope with Intermittent Malfunction [P.00-15.](#))

STEP 5. Check whether the DTC is reset.**Q: Is DTC U0401 set?**

YES : Return to Step 1.

NO : The procedure is complete.

DTC U0428: Communication error in steering wheel sensor

 **CAUTION**

- If diagnostic trouble code U0428 is set in ASC-ECU, always diagnose the CAN bus lines. If there is any fault in the CAN bus lines, an incorrect DTC may be set.
- Whenever the ECU is replaced, ensure that the CAN bus lines are normal.
- When the steering wheel sensor is replaced, always perform calibration to make ASC-ECU learn the neutral point. (Refer to [P.35C-289](#).)
- When the hydraulic unit (integrated with ASC-ECU) is replaced, after turning the ignition switch ON and OFF (vehicle information from ETACS-ECU is registered), always perform the calibration of steering wheel sensor, G and yaw rate sensor, brake fluid pressure sensor, cut valve, and inlet valve.(Refer to [P.35C-287](#), [P.35C-289](#), [P.35C-294](#), and [P.35C-295](#).)

CIRCUIT OPERATION

The steering wheel sensor outputs the steering wheel status to ASC-ECU via the CAN bus lines.

DTC SET CONDITIONS

This diagnostic trouble code is set when ASC-ECU has detected the communication error in the steering wheel sensor.

PROBABLE CAUSES

- Steering wheel sensor malfunction
- ASC-ECU malfunction
- External noise interference

DIAGNOSIS**Required Special Tools:**

- MB991958 Scan Tool (M.U.T.-III Sub Assembly)
 - MB991824: Vehicle Communication Interface (V.C.I.)
 - MB991827 M.U.T.-III USB Cable
 - MB991910 M.U.T.-III Main Harness A

STEP 1. Using scan tool MB991958, diagnose the CAN bus lines.

Using scan tool MB991958, diagnose the CAN bus lines.

Q: Is the check result normal?

YES : Replace the steering wheel sensor.(Refer to [P.35C-305.](#)) Then go to Step 2.

NO : Repair the CAN bus lines. (Refer to GROUP 54C – Troubleshooting [P.54C-15.](#)) After repairing the CAN bus line, go to Step 3.

STEP 2. Check whether the DTC is reset.**Q: Is DTC U0428 set?**

YES : Replace the hydraulic unit (incorporates in ASC-ECU).(Refer to [P.35C-298.](#)) Then go to Step 3.

NO : The procedure is complete.

STEP 3. Check whether the DTC is reset.**Q: Is DTC U0428 set?**

YES : Return to Step 1.

NO : The procedure is complete.

DTC U0251: AWC time-out error (Local CAN)
DTC U0440: AWC communication error in AWC (Local CAN)
DTC U0435: AWC signal abnormality (Local CAN)

G and Yaw Rate Sensor Circuit

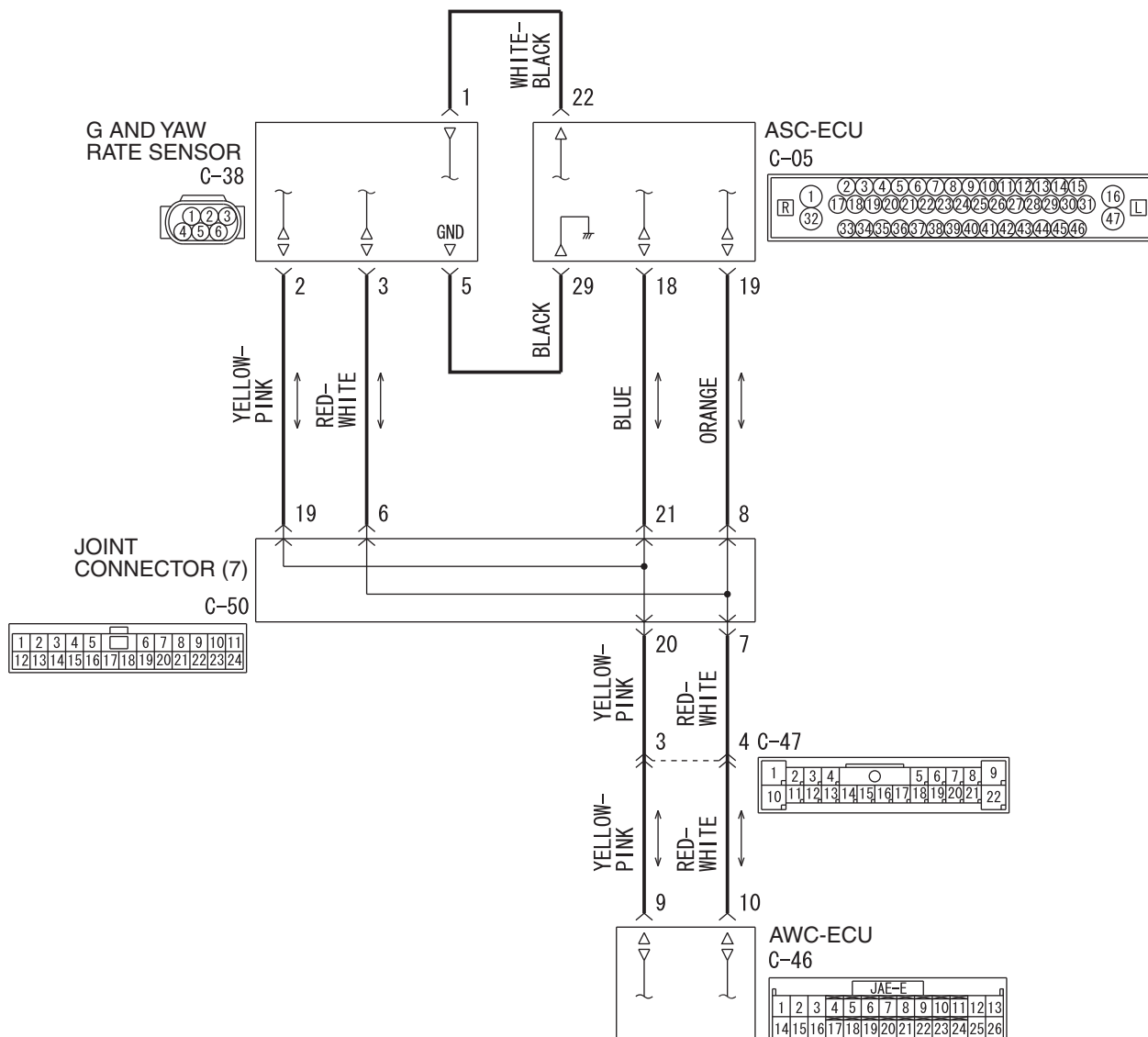

WAH35M012A

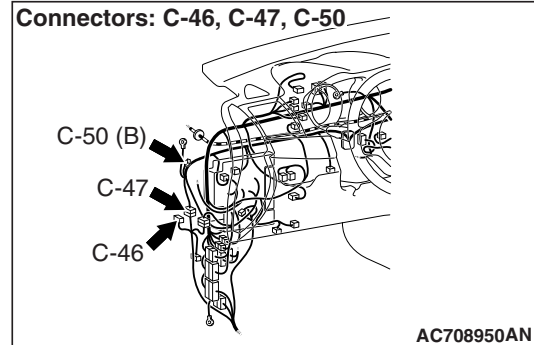
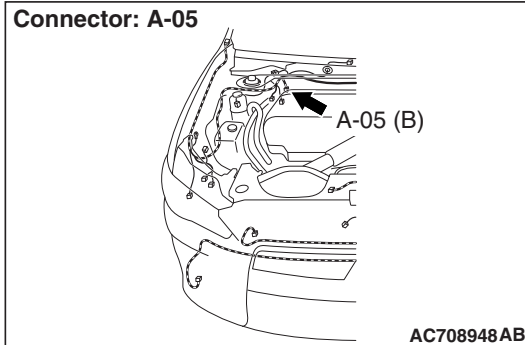

⚠ CAUTION

- If there is any problem in the CAN bus lines, an incorrect diagnostic trouble code may be set. Prior to this diagnosis, diagnose the CAN bus lines.
- Whenever the ECU is replaced, ensure that the CAN bus lines are normal.
- When the hydraulic unit (integrated with ASC-ECU) is replaced, always perform the calibration of steering wheel sensor, G and yaw rate sensor, brake fluid pressure sensor, cut valve, and inlet valve. (Refer to [P.35C-287](#), [P.35C-289](#), [P.35C-294](#), and [P.35C-295](#).)

CIRCUIT OPERATION

AWC-ECU outputs the signal to ASC-ECU via the special CAN bus lines (Local CAN).

DTC SET CONDITIONS

These diagnostic trouble codes will be set under the cases below.

DTC U0251

- Signals sent from AWC-ECU to ASC-ECU cannot be received for a specified period.

DTC U0440

- Signals sent from AWC-ECU to ASC-ECU have an error.

DTC U0435

- A brake control request of outside the specified range is output by AWC-ECU.

PROBABLE CAUSES

- Wiring harness or connector failure in special CAN bus lines (Local CAN) between ASC-ECU and AWC-ECU
- AWC-ECU malfunction
- ASC-ECU malfunction

DIAGNOSIS

Required Special Tools:

- MB991958 Scan Tool (M.U.T.-III Sub Assembly)
 - MB991824: Vehicle Communication Interface (V.C.I.)
 - MB991827 M.U.T.-III USB Cable
 - MB991910 M.U.T.-III Main Harness A

STEP 1. Using scan tool MB991958, diagnose the CAN bus lines.

Using scan tool MB991958, diagnose the CAN bus lines.

Q: Is the check result normal?

YES : Go to Step 3.

NO : Repair the CAN bus lines. (Refer to GROUP 54C – Troubleshooting P.54C-15.) After repairing the CAN bus line, go to Step 2.

STEP 2. DTC recheck after repairing the CAN bus line

Q: Is DTC U0251, U0440 or U0435 set?

YES : Go to Step 3.

NO : This diagnosis is complete.

STEP 3. Diagnostic trouble code check of other system using scan tool MB991958

Using scan tool MB991958, check if a diagnostic trouble code is set in AWC-ECU.

Q: Is other DTC set?

YES : Troubleshoot the relevant diagnostic trouble code, and then go to Step 8.

NO : Go to Step 4.

STEP 4. Connector check: A-05 ASC-ECU connector, C-46 AWC-ECU connector, C-47 intermediate connector, C-50 joint connector

Q: Is the check result normal?

YES : Go to Step 5.

NO : Repair the connector, and then go to Step 8.

STEP 5. Wiring harness check between A-05 ASC-ECU connector terminal No. 18 and C-46 AWC-ECU connector terminal No. 9, between A-05 ASC-ECU connector terminal No. 19 and C-46 AWC-ECU connector terminal No. 10

- Open or short circuit check of communication circuit

Q: Is the check result normal?

YES : Go to Step 6.

NO : Repair the wiring harness, and then go to Step 8.

STEP 6. Check whether the DTC is reset.**Q: Are DTC U0251, U0440, and U0435 set?**

YES : Replace the AWC-ECU. (Refer to GROUP 22A – Manual Transaxle, AWC-ECU [P.22A-133.](#)) Then go to Step 7.

NO : Intermittent malfunction. (Refer to GROUP 00 –How to Cope with Intermittent Malfunction [P.00-15.](#))

STEP 7. Check whether the DTC is reset.**Q: Is DTC U0251, U0440 or U0435 set?**

YES : Replace the hydraulic unit (incorporates in ASC-ECU). (Refer to [P.35C-298.](#)) Then go to Step 8.

NO : The procedure is complete.

STEP 8. Check whether the DTC is reset.**Q: Is DTC U0251, U0440 or U0435 set?**

YES : Return to Step 1.

NO : The procedure is complete.

DTC U1003: G and yaw rate sensor bus-off

G and Yaw Rate Sensor Circuit

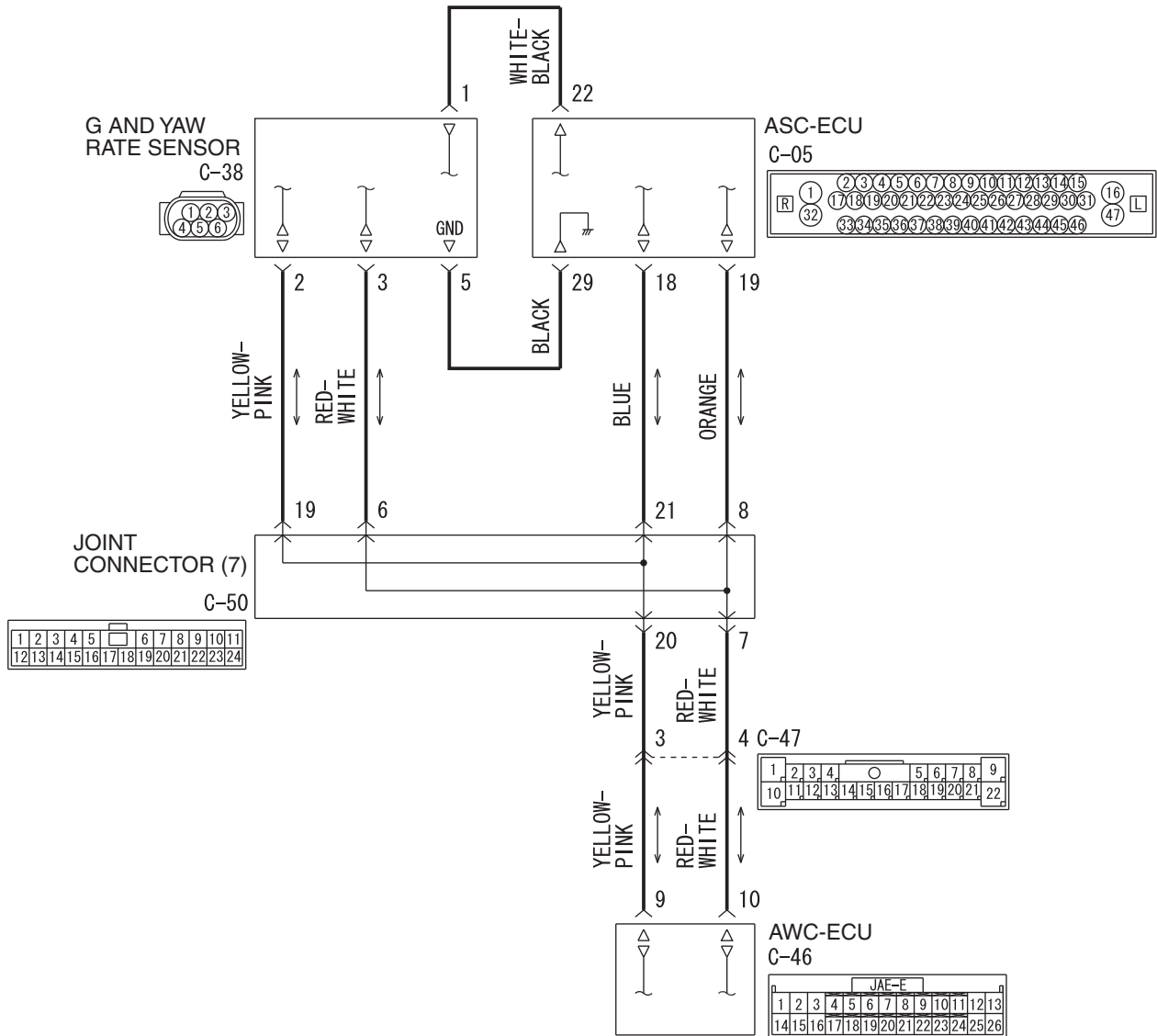

WAH35M012A

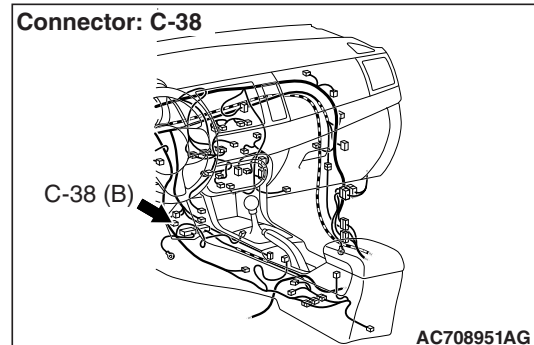
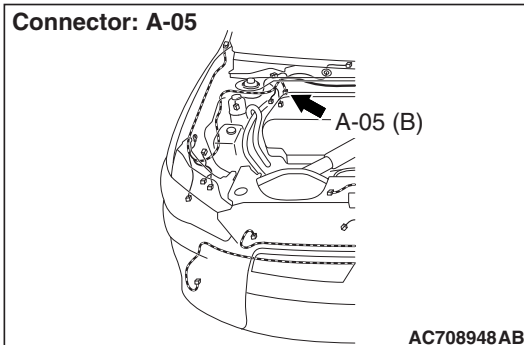

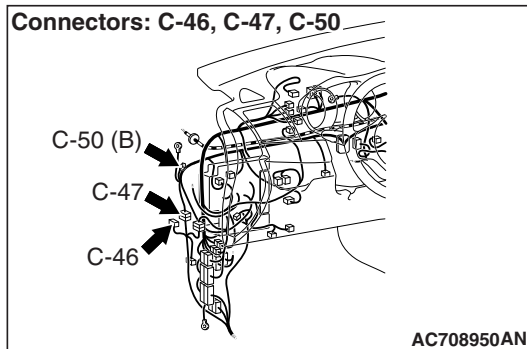

⚠ CAUTION

- If there is any problem in the CAN bus lines, an incorrect diagnostic trouble code may be set. Prior to this diagnosis, diagnose the CAN bus lines.
- Whenever the ECU is replaced, ensure that the CAN bus lines are normal.
- Do not drop the G and yaw rate sensor or subject it to a shock.
- When the G and yaw rate sensor is replaced, always perform the calibration to make ASC-ECU learn the neutral point (Refer to [P.35C-287](#).)
- When the hydraulic unit (integrated with ASC-ECU) is replaced, after turning the ignition switch ON and OFF (vehicle information from ETACS-ECU is registered), always perform the calibration of steering wheel sensor, G and yaw rate sensor, brake fluid pressure sensor, cut valve, and inlet valve (Refer to [P.35C-287](#), [P.35C-289](#), [P.35C-294](#), and [P.35C-295](#).)

CIRCUIT OPERATION

The G and yaw rate sensor outputs the signal to ASC-ECU and AWC-ECU via the local CAN bus lines.

DTC SET CONDITIONS

This diagnostic trouble code is set when ASC-ECU cannot receive the signal sent from the G and yaw rate sensor.

PROBABLE CAUSES

- Wiring harness or connector failure in special CAN bus lines between ASC-ECU and G and yaw rate sensor
- G and yaw rate sensor malfunction
- ASC-ECU malfunction

DIAGNOSIS

Required Special Tools:

- MB991958 Scan Tool (M.U.T.-III Sub Assembly)
 - MB991824: Vehicle Communication Interface (V.C.I.)
 - MB991827 M.U.T.-III USB Cable
 - MB991910 M.U.T.-III Main Harness A

STEP 1. Using scan tool MB991958, diagnose the CAN bus lines.

Using scan tool MB991958, diagnose the CAN bus lines.

Q: Is the check result normal?

YES : Go to Step 3.

NO : Repair the CAN bus lines. (Refer to GROUP 54C – Troubleshooting [P.54C-15.](#)) After repairing the CAN bus line, go to Step 2.

STEP 2. DTC recheck after repairing the CAN bus line

Q: Is DTC U1003 set?

YES : Go to Step 3.

NO : The procedure is complete.

STEP 3. Connector check: A-05 ASC-ECU connector, C-46 AWC-ECU connector, C-47 intermediate connector, C-50 joint connector

Q: Is the check result normal?

YES : Go to Step 4.

NO : Repair the connector, and then go to Step 7.

STEP 4. Wiring harness check between A-05 ASC-ECU connector terminal No. 18 and C-38 G and yaw rate sensor connector terminal No. 2, between A-05 ASC-ECU connector terminal No. 19 and C-38 G and yaw rate sensor connector terminal No. 3, between C-46 AWC-ECU connector terminal No. 9 and C-38 G and yaw rate sensor connector terminal No. 2, between C-46 AWC-ECU connector terminal No. 10 and C-38 G and yaw rate sensor connector terminal No. 3

- Open or short circuit check of communication circuit

Q: Is the check result normal?

YES : Go to Step 5.

NO : Repair the wiring harness, and then go to Step 7.

STEP 5. Check whether the DTC is reset.

Q: Is DTC U1003 set?

YES : Replace the G and yaw rate sensor. (Refer to [P.35C-304.](#)) Then go to Step 6.

NO : Intermittent malfunction. (Refer to GROUP 00 –How to Cope with Intermittent Malfunction [P.00-15.](#))

STEP 6. Check whether the DTC is reset.

Q: Is DTC U1003 set?

YES : Replace the hydraulic unit (incorporates in ASC-ECU). (Refer to [P.35C-298.](#)) Then go to Step 7.

NO : The procedure is complete.

STEP 7. Check whether the DTC is reset.**Q: Is DTC U1003 set?****YES** : Return to Step 1.**NO** : The procedure is complete.

DTC U1415: Variant coding not completed

⚠ CAUTION

- If there is any problem in the CAN bus lines, an incorrect diagnostic trouble code may be set. Prior to this diagnosis, diagnose the CAN bus lines.
- Whenever the ECU is replaced, ensure that the CAN bus lines are normal.
- When diagnostic trouble code No. U1415 is set in ASC-ECU, the diagnostic trouble code may also be set in ETACS-ECU. When the diagnostic trouble code is set in ETACS-ECU, perform the diagnosis of the diagnostic trouble code for ETACS-ECU first.
- When the hydraulic unit (integrated with ASC-ECU) is replaced, after turning the ignition switch ON and OFF (vehicle information from ETACS-ECU is registered), always perform the calibration of steering wheel sensor, G and yaw rate sensor, brake fluid pressure sensor, cut valve, and inlet valve. (Refer to [P.35C-287](#), [P.35C-289](#), [P.35C-294](#), and [P.35C-295](#).)

CIRCUIT OPERATION

ASC-ECU receives the vehicle information stored in the ETACS-ECU via CAN bus lines.

DTC SET CONDITIONS

This diagnostic trouble code is set when the variant coding for ETACS-ECU has not been completed.

PROBABLE CAUSES

- Variant coding for ETACS-ECU has not been implemented.
- ASC-ECU malfunction

DIAGNOSIS**Required Special Tools:**

- MB991958 Scan Tool (M.U.T.-III Sub Assembly)
 - MB991824: Vehicle Communication Interface (V.C.I.)
 - MB991827 M.U.T.-III USB Cable
 - MB991910 M.U.T.-III Main Harness A

STEP 1. Using scan tool MB991958, diagnose the CAN bus lines.

Using scan tool MB991958, diagnose the CAN bus lines.

Q: Is the check result normal?

YES : Go to Step 2.

NO : Repair the CAN bus lines. (Refer to GROUP 54C – Troubleshooting [P.54C-15](#).) After repairing the CAN bus line, go to Step 5.

STEP 2. Scan tool diagnostic trouble code for other system

Use scan tool to check that the diagnostic trouble code B222C is set in the ETACS-ECU.

Q: Is any DTC set?

YES : Perform troubleshooting for the diagnostic trouble code that is set. Then go to Step 4.

NO : Go to Step 3.

STEP 3. Check for diagnostic trouble codes

Q: Is DTC U1417 set?

YES : Perform the troubleshooting for diagnostic trouble code No. U1417. (Refer to [P.35C-228](#).)

NO : Go to Step 4.

STEP 4. Check whether the DTC is reset.

- (1) Ignition switch "LOCK" (OFF)
- (2) Ignition switch "ON"
- (3) Check that the ABS warning light is extinguished.

Q: Is DTC U1415 set?

YES : Replace the hydraulic unit (incorporates in ASC-ECU).(Refer to [P.35C-298](#).) Then go to Step 5.

NO : Intermittent malfunction. (Refer to GROUP 00 –How to Cope with Intermittent Malfunction [P.00-15](#).)

STEP 5. Check whether the DTC is reset.

- (1) Ignition switch "LOCK" (OFF)
- (2) Ignition switch "ON"
- (3) Check that the ABS warning light is extinguished.

Q: Is DTC U1415 set?

YES : Return to Step 1.

NO : The procedure is complete.

DTC U1417: Variant coding value invalid (includes faulty installation)

⚠ CAUTION

- If diagnostic trouble code No. U1417 is set in ASC-ECU, always diagnose the CAN bus lines. If there is any fault in the CAN bus lines, an incorrect DTC may be set.
- Whenever the ECU is replaced, ensure that the communication circuit is normal.
- When diagnostic trouble code No. U1417 is set in ASC-ECU, the diagnostic trouble code may also be set in ETACS-ECU. When the diagnostic trouble code is set in ETACS-ECU, perform the diagnosis of the diagnostic trouble code for ETACS-ECU first.
- When the hydraulic unit (integrated with ASC-ECU) is replaced, after turning the ignition switch ON and OFF (vehicle information from ETACS-ECU is registered), always perform the calibration of steering wheel sensor, G and yaw rate sensor, brake fluid pressure sensor, cut valve, and inlet valve. (Refer to [P.35C-287](#), [P.35C-289](#), [P.35C-294](#), and [P.35C-295](#).)

CIRCUIT OPERATION

ASC-ECU receives the vehicle information stored in the ETACS-ECU via CAN bus lines.

DTC SET CONDITIONS

ASC-ECU communicates with ETACS-ECU via CAN bus lines. This diagnostic trouble code is set when the vehicle information received from ETACS-ECU is invalid.

This diagnostic trouble code is also set when the engine control module sends the ASC intervention rejection (ASC not supported) signal consecutively.

PROBABLE CAUSES

- ETACS-ECU malfunction
- ECM malfunction
- ETACS-ECUs have been interchanged between two vehicles.
- ASC-ECU malfunction
- Noise interference
- ASC-ECUs have been interchanged between two vehicles.

DIAGNOSIS

Required Special Tools:

- MB991958 Scan Tool (M.U.T.-III Sub Assembly)
 - MB991824: Vehicle Communication Interface (V.C.I.)
 - MB991827 M.U.T.-III USB Cable
 - MB991910 M.U.T.-III Main Harness A

STEP 1. Using scan tool MB991958, diagnose the CAN bus lines.

Using scan tool MB991958, diagnose the CAN bus lines.

Q: Is the check result normal?

YES : Go to Step 3.

NO : Repair the CAN bus lines. (Refer to GROUP 54C – Troubleshooting [P.54C-15](#).) After repairing the CAN bus line, go to Step 2.

STEP 2. DTC recheck after repairing the CAN bus line

Q: Is DTC U1417 set?

YES : Go to Step 3.

NO : This diagnosis is complete.

STEP 3. Check for diagnostic trouble codes

Check if diagnostic trouble code No. C121C is set in ASC-ECU.

Q: Is the check result normal?

YES : Perform troubleshooting for the diagnostic trouble code that is set. (Refer to [P.35C-166](#).)

NO : Go to Step 4.

STEP 4. Scan tool diagnostic trouble code for other systems

Use scan tool to check whether any diagnostic trouble code related to vehicles information is set or not by the ETACS-ECU or engine control module (ECM).

Q: Is any DTC set?

YES : Perform troubleshooting for the diagnostic trouble code that is set.

NO : Go to Step 5.

STEP 5. ETACS-ECU coding data check

Using the scan tool, check if there is any abnormality to the following coding data stored in the ETACS-ECU. (Refer to GROUP 00 –Coding Table [P.00-26](#).)

Vehicle line

OK: LANCER EVO

Transaxle

OK (Vehicles without TC-SST): 5MT

OK (Vehicles with TC-SST): TC-SST

Engine type

OK: D4 V.V.T. 2.0L TC

Engine power

OK: Normal

Chassis Type for A.S.C.

OK: Type 1

Final drive

OK: AWD FF Base

Transfer

OK: ACD

SAS

OK: Present

AWD

OK: Not present

TCM

OK (Vehicles without TC-SST): Not present

OK (Vehicles with TC-SST): Present

ACDAYC

OK: Present

Q: Is the check result normal?

YES : Go to Step 6.

NO : Replace the ETACS-ECU. (Refer to GROUP 54A – ETACS-ECU [P.54A-742](#).) Then go to Step 10.

STEP 6. Engine control module coding data check

Using the scan tool, check if there is any abnormality to the coding data stored in the engine control module. (Refer to GROUP 00 –Coding Table [P.00-26](#).)

Q: Is the check result normal?

YES : Go to Step 7.

NO : Replace the engine control module. (Refer to GROUP 13A –Engine Control Module [P.13A-888](#).) Then go to Step 10.

STEP 7. Check of ETACS-ECU part number

Check the part number of ETACS-ECU.

Q: Is the check result normal?

YES : Go to Step 8.

NO : Replace the ETACS-ECU. (Refer to GROUP 54A – ETACS-ECU [P.54A-742.](#)) Then go to Step 10.

STEP 8. Check of ASC-ECU part number

Check the part number of ASC-ECU.

Q: Is the check result normal?

YES : Go to Step 9.

NO : Replace the hydraulic unit (incorporates in ASC-ECU).(Refer to [P.35C-298.](#)) Then go to Step 10.

STEP 9. Check whether the DTC is reset.

Q: Is DTC U1417 set?

YES : Replace the hydraulic unit (incorporates in ASC-ECU).(Refer to [P.35C-298.](#)) Then go to Step 10.

NO : Intermittent malfunction. (Refer to GROUP 00 –How to Cope with Intermittent Malfunction [P.00-15.](#))

STEP 10. Check whether the DTC is reset.

Q: Is DTC U1417 set?

YES : Return to Step 1.

NO : The procedure is complete.

Trouble symptom chart

⚠ CAUTION

- **ABS may operate in the following conditions without hard braking: Low mu road surface, high-speed turn, and bumpy road surface. When asking the customers, confirm if they have encountered ABS operation in corresponding conditions.**
- **Even when the ASC operation display does not appear, the ASC operation noise (pump, motor, and others) may be generated. This occurs because the pump, motor, and others operate to accumulate the braking force before the application of braking force to wheels, and it is not a malfunction.**
- **During ABS operation, as the brake pedal is gradually drawn inward, the noise is generated. This occurs because the brake line pressure varies intermittently to prevent the wheel lock, and it is not a malfunction.**

⚠ CAUTION

During diagnosis, a DTC associated with other system may be set when the ignition switch is turned ON with connector(s) disconnected. On completion, confirm all systems for diagnostic trouble code(s). If diagnostic trouble code(s) are set, erase them all.

Trouble symptoms		Inspection procedure number	Reference page
The scan tool cannot communicate with the ABS/ASC system.	The scan tool cannot communicate with all systems.	–	Refer to GROUP 54C – Troubleshooting P.54C-15.
	The scan tool cannot communicate only with ASC-ECU.	1	P.35C-233
With the parking brake released, the brake warning light remains illuminated (ABS warning light is turned off).		2	P.35C-234
The ABS warning light does not illuminate when ignition switch is turned to the ON position (engine stopped).		3	P.35C-239
The brake warning light does not illuminate when ignition switch is turned to the ON position (engine stopped).		4	P.35C-242
The ABS warning light remains illuminated even after the engine is started.		5	P.35C-244
The ASC warning display remains illuminated even after the engine is started.		6	P.35C-246
The ASC OFF display remains illuminated after the engine is started.		7	P.35C-248
After the ASC OFF switch is pressed to turn "OFF," the skid control/TCL cannot be cancelled.		8	P.35C-252
Abnormality in brake operation		9	P.35C-255
Skid control/TCL does not operate.		10	P.35C-256
ASC-ECU power supply circuit system		11	P.35C-258
ABS/skid control/TCL operates too frequently.		12	P.35C-267
Steering wheel sensor power supply circuit system		13	P.35C-271

SYMPTOM PROCEDURES

Inspection Procedure 1: The scan tool cannot communicate with the ABS/ASC system.

⚠ CAUTION

- If there is any problem in the CAN bus lines, an incorrect diagnostic trouble code may be set. Prior to this diagnosis, diagnose the CAN bus lines.
- Whenever the ECU is replaced, ensure that the CAN bus lines are normal.
- If the power is supplied with the ground circuit of CAN communication devices open circuited, a potential abnormality may occur to the connected CAN bus line.
- When the hydraulic unit (integrated with ASC-ECU) is replaced, always perform the calibration of steering wheel sensor, G and yaw rate sensor, brake fluid pressure sensor, cut valve, and inlet valve.(Refer to [P.35C-287](#), [P.35C-289](#), [P.35C-294](#), and [P.35C-295](#).)

TECHNICAL DESCRIPTION (COMMENT)

When the scan tool MB991958 cannot communicate with the ABS/ASC system, there may be a malfunction to the CAN bus lines, ASC-ECU power supply circuit, ground, or ASC-ECU.

PROBABLE CAUSES

- Damaged wiring harness and connectors
- ASC-ECU malfunction
- Wrong M.U.T.-III wiring harness
- Abnormality in battery or generator
- Abnormality in power supply voltage to ASC-ECU
- ECU malfunction of other system

DIAGNOSIS

Required Special Tools:

- MB991958: Scan Tool (M.U.T.-III Sub Assembly)
 - MB991824: Vehicle Communication Interface (V.C.I.)
 - MB991827: M.U.T.-III USB Cable
 - MB991910: M.U.T.-III Main Harness A

Using scan tool MB991958, diagnose the CAN bus lines.

Using the scan tool, diagnose the CAN bus lines.

Q: Is the check result normal?

YES : Check and repair the power supply circuit system. (Refer to [P.35C-258](#).)

NO : Repair the CAN bus lines. (Refer to GROUP 54C – Troubleshooting [P.54C-15](#).)

Inspection Procedure 2: With the parking brake released, the brake warning light remains illuminated (ABS warning light is turned off).

Brake Fluid Level Switch and Parking Brake Switch Circuit

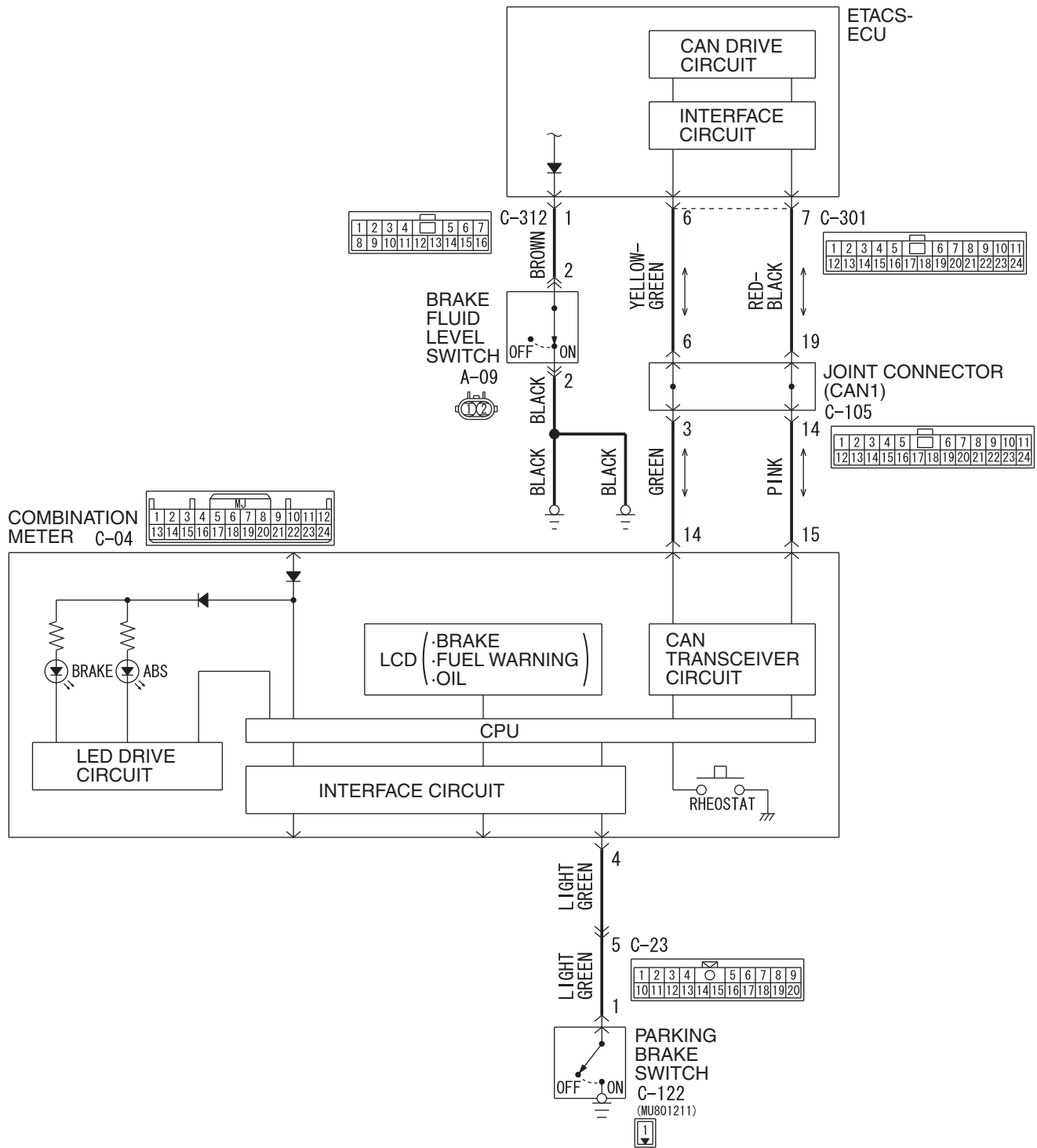

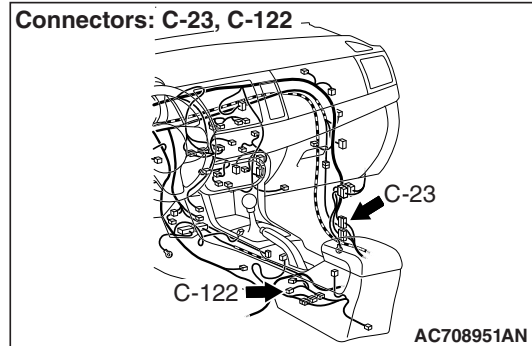
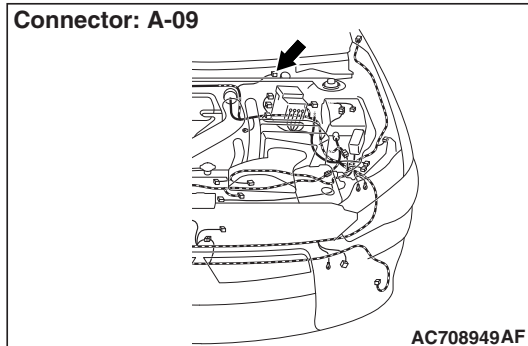
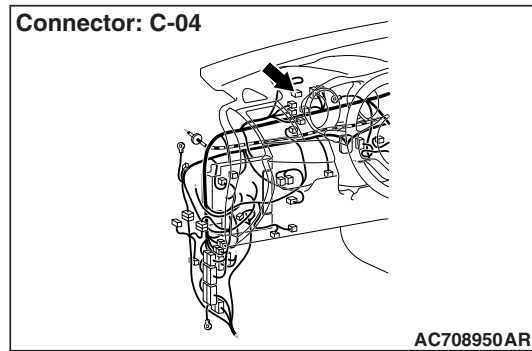
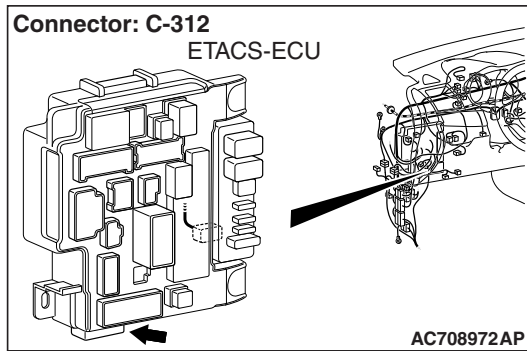

⚠ CAUTION

- If there is any problem in the CAN bus lines, an incorrect diagnostic trouble code may be set. Prior to this diagnosis, diagnose the CAN bus lines.
- Whenever the ECU is replaced, ensure that the communication circuit is normal.

CIRCUIT OPERATION

- When the parking brake switch is turned ON, the combination meter terminal No. 4 is grounded, and then the brake warning light is illuminated.
- When the brake fluid level drop is detected, the brake fluid level switch is turned from ON to OFF. ETACS-ECU monitors the brake fluid level switch, and gives an instruction via the CAN bus line to the combination meter to illuminate the brake warning light.

PROBABLE CAUSES

- The brake pad thickness is at the limit value or less.
- The brake fluid amount is at the "LOWER" level or lower.
- Poor adjustment of the parking brake lever
- Damaged wiring harness and connectors
- Parking brake switch malfunction
- Brake fluid level switch malfunction
- Combination meter malfunction
- ETACS-ECU malfunction

DIAGNOSIS**Required Special Tools:**

- MB991958 Scan Tool (M.U.T.-III Sub Assembly)
 - MB991824: Vehicle Communication Interface (V.C.I.)
 - MB991827 M.U.T.-III USB Cable
 - MB991910 M.U.T.-III Main Harness A

STEP 1. Using scan tool MB991958, diagnose the CAN bus lines.

Using scan tool MB991958, diagnose the CAN bus lines.

Q: Is the check result normal?

YES : Go to Step 2.

NO : Repair the CAN bus lines. (Refer to GROUP 54C – Troubleshooting [P.54C-15.](#))

STEP 2. Scan tool diagnostic trouble code for other systems

Using scan tool MB991958, check if the diagnostic trouble code is set in the combination meter and ETACS-ECU.

Q: Is any DTC set?

YES : Carry out the diagnosis for the DTC.

NO : Go to Step 3.

STEP 3. Brake fluid level check

Check that the brake fluid is filled up to the "MIN" level or higher.

Q: Is the check result normal?

YES : Go to Step 5.

NO : Go to Step 4.

STEP 4. Brake pad check

Refer to GROUP 35A –On-vehicle Service, Brake Pad Check [P.35A-18.](#)

Q: Is the check result normal?

YES : Fill the brake fluid up to the "MAX" level. Then go to Step 18.

NO : Replace the brake pad. (Refer to GROUP 35A – On-vehicle Service, Brake Pad Replacement [P.35A-18.](#)) Then, go to Step 18.

STEP 5. Brake fluid level switch check

Refer to GROUP 35A –On-vehicle Service, Brake Fluid Level Switch Check [P.35A-17.](#)

Q: Is the check result normal?

YES : Go to Step 6.

NO : Replace the reservoir tank assembly. (Refer to GROUP 35A –Master Cylinder Assembly and Brake Booster Assembly [P.35A-26.](#)) Then, go to Step 18.

STEP 6. Connector check: C-312 ETACS-ECU connector, A-09 brake fluid level switch connector

Q: Is the check result normal?

YES : Go to Step 7.

NO : Repair the defective connector.

STEP 7. Voltage measurement at A-09 brake fluid level switch connector

- (1) Disconnect the connector, and measure at the wiring harness side.
- (2) Turn the ignition switch to the ON position.
- (3) Measure the voltage between the terminal No.2 and the body ground.

OK: Battery positive voltage

Q: Is the check result normal?

YES : Go to Step 9.

NO : Go to Step 8.

STEP 8. Voltage measurement at C-312 ETACS-ECU connector



Keep the C-312 ETACS-ECU connector remain connected, then disconnect A-09 brake fluid level switch connector.

- (1) Turn the ignition switch to the ON position.
- (2) Measure the voltage between the terminal No. 1 and the body ground by backprobing.

OK: Approximately battery voltage

Q: Is the check result normal?

YES : Repair the wiring harness between C-312 ETACS-ECU connector terminal No. 1 and A-09 brake fluid level switch connector terminal No. 2.

NO : Replace the ETACS-ECU. (Refer to GROUP 54A – ETACS [P.54A-742.](#)) Then go to Step 18.

STEP 9. Wiring harness check: Between A-09 brake fluid level switch connector and the body ground

Check for an open circuit in the wiring harness between A-09 brake fluid level switch connector terminal No. 1 and the body ground.

Q: Is the check result normal?

YES : Go to Step 10.

NO : Repair the wiring harness.

STEP 10. Parking brake lever stroke check

Refer to GROUP 36 –On-vehicle Service [P.36-8.](#)

Q: Is the check result normal?

YES : Go to Step 11.

NO : Adjust the parking brake lever stroke (Refer to GROUP 36 –On-vehicle Service [P.36-8.](#)) Then, go to Step 18.

STEP 11. Parking brake switch check

Refer to GROUP 36 –On-vehicle Service [P.36-9](#).

Q: Is the check result normal?

YES : Go to Step 12.

NO : Replace the parking brake switch (Refer to GROUP 36 –Parking Brake Lever [P.36-10](#).) Then, go to Step 18.

STEP 12. Connector check: C-122 parking brake switch connector**Q: Is the check result normal?**

YES : Go to Step 13.

NO : Repair the defective connector.

STEP 13. Voltage measurement at C-122 parking brake switch connector

- (1) Disconnect the connector, and measure at the wiring harness side.
- (2) Turn the ignition switch to the ON position.
- (3) Measure the voltage between the terminal No. 1 and the body ground.

OK: Battery positive voltage

Q: Is the check result normal?

YES : Go to Step 17.

NO : Go to Step 14.

STEP 14. Connector check: C-04 combination meter connector, C-23 intermediate connector**Q: Is the check result normal?**

YES : Go to Step 15.

NO : Repair the defective connector.

STEP 15. Voltage measurement at C-04 combination meter connector

- (1) Release the parking brake lever (not operated).
- (2) Turn the ignition switch to the ON position.
- (3) Without disconnecting the connector, measure the voltage between the terminal No. 4 and the body ground by backprobing.

OK: Battery positive voltage

Q: Is the check result normal?

YES : Go to Step 17.

NO : Go to Step 16.

STEP 16. Wiring harness check: Between C-04 combination meter connector and C-122 parking brake switch connector

Check for a short circuit in the wiring harness between C-04 combination meter connector terminal No. 4 and C-122 parking brake switch connector terminal No. 1.

Q: Is the check result normal?

YES : Go to Step 17.

NO : Repair the wiring harness.

STEP 17. Retest the system.

Q: Does the brake warning light turn ON and OFF normally according to the parking brake lever operation?

YES : Intermittent malfunction. (Refer to GROUP 00 –How to Cope with Intermittent Malfunction [P.00-15.](#))

NO : Replace the combination meter assembly. (Refer to GROUP 54A –Combination Meter [P.54A-110.](#)) Then, go to Step 18.

STEP 18. Retest the system.

Q: Does the brake warning light turn ON and OFF normally according to the parking brake lever operation?

YES : The procedure is complete.

NO : Return to Step 1.

Inspection Procedure 3: The ABS warning light does not illuminate when ignition switch is turned to the ON position (engine stopped).

⚠ CAUTION

- If there is any problem in the CAN bus lines, an incorrect diagnostic trouble code may be set. Prior to this diagnosis, diagnose the CAN bus lines.
- Whenever the ECU is replaced, ensure that the CAN bus lines are normal.
- When the hydraulic unit (integrated with ASC-ECU) is replaced, always perform the calibration of steering wheel sensor, G and yaw rate sensor, brake fluid pressure sensor, cut valve, and inlet valve.(Refer to [P.35C-287](#), [P.35C-289](#), [P.35C-294](#), and [P.35C-295.](#))

SYSTEM OPERATION

- ASC-ECU sends the illumination signal of ABS warning light to the combination meter through ETACS-ECU via CAN communication.
- When the ignition switch is turned ON, ASC-ECU illuminates the ABS warning light via ETACS-ECU for approximately 3 seconds for the purpose of bulb check.

TECHNICAL DESCRIPTION (COMMENT)

In the case of this trouble symptom, there may be a malfunction to the CAN bus line, ETACS-ECU, combination meter, or ASC-ECU.

PROBABLE CAUSES

- Damaged harness wires and connectors
- Malfunction of the ETACS-ECU
- Malfunction of the combination meter
- Malfunction of ASC-ECU
- Abnormality with ETACS-ECU coding data

DIAGNOSIS**Required Special Tools:**

- MB991958 Scan Tool (M.U.T.-III Sub Assembly)
 - MB991824: Vehicle Communication Interface (V.C.I.)
 - MB991827 M.U.T.-III USB Cable
 - MB991910 M.U.T.-III Main Harness A

STEP 1. Using scan tool MB991958, diagnose the CAN bus line.

Using scan tool MB991958, diagnose the CAN bus lines.

Q: Is the check result normal?

YES : Go to Step 2.

NO : Repair the CAN bus lines. (Refer to GROUP 54C – Troubleshooting [P.54C-15](#).) Then go to Step 8.

STEP 2. Scan tool diagnostic trouble code

Using scan tool, check the diagnostic trouble code for ASC system.

Q: Is the DTC set?

YES : Carry out the diagnosis for the diagnostic trouble code. (Refer to [P.35C-22](#)).

NO : Go to Step 3.

STEP 3. M.U.T.-III actuator test

Perform the following actuator tests from the combination meter system to check if the ABS warning light is illuminated. (Refer to GROUP 54A –Combination Meter, Actuator Test Table [P.54A-89](#).)

- Item 07: Indicator1

Q: Is the check result normal?

YES : Go to Step 4.

NO : Carry out the diagnosis of the combination meter. (Refer to GROUP 54A –Combination Meter, Trouble Symptom Chart [P.54A-67](#).) Then go to Step 8.

STEP 4. Coding data check

Using the scan tool, check if there is any abnormality to the coding data stored in the ETACS-ECU. (Refer to GROUP 00 – Coding Table [P.00-26](#).)

Q: Is the check result normal?

YES : Go to Step 5.

NO : Replace the ETACS-ECU. (Refer to GROUP 54A – ETACS-ECU [P.54A-742](#).) Then go to Step 8.

STEP 5. Scan tool diagnostic trouble code for other systems

Using scan tool MB991958, check if diagnostic trouble code No. U0141 is set by the combination meter system.

Q: Is the DTC set?

YES : Diagnose the combination meter. (Refer to GROUP 54A –Combination Meter, Troubleshooting [P.54A-49](#).) Then go to Step 8.

NO : Go to Step 6.

STEP 6. Scan tool diagnostic trouble code for other systems

Using scan tool MB991958, check if diagnostic trouble code No. U0121 is set by ETACS system.

Q: Is the DTC set?

YES : Diagnose the ETACS-ECU. (Refer to GROUP 54A – ETACS, Troubleshooting [P.54A-655](#).) Then go to Step 8.

NO : Go to Step 7.

STEP 7. Retest the system.

Q: Does the ABS warning light turn ON and OFF normally?

YES : Intermittent malfunction. (Refer to GROUP 00 –How to Cope with Intermittent Malfunction [P.00-15](#).)

NO : Replace the hydraulic unit (incorporates in ASC-ECU).(Refer to [P.35C-298](#).) Then go to Step 8.

STEP 8. Retest the system.

Q: Does the ABS warning light turn ON and OFF normally?

YES : The procedure is complete.

NO : Return to Step 1.

Inspection Procedure 4: The brake warning light does not illuminate when ignition switch is turned to the ON position (engine stopped).

⚠ CAUTION

- Whenever the ECU is replaced, ensure that the CAN bus lines are normal.
- When the hydraulic unit (integrated with ASC-ECU) is replaced, always perform the calibration of steering wheel sensor, G and yaw rate sensor, brake fluid pressure sensor, cut valve, and inlet valve. (Refer to [P.35C-287](#), [P.35C-289](#), [P.35C-294](#), and [P.35C-295](#).)

CIRCUIT OPERATION

- ASC-ECU sends the illumination request signal of the brake warning light to the combination meter through ETACS-ECU via CAN communication.
- When the ignition switch is turned ON, ASC-ECU illuminates the brake warning light via ETACS-ECU for approximately 3 seconds for the purpose of bulb check.

TECHNICAL DESCRIPTION (COMMENT)

In the case of this trouble symptom, there may be a malfunction to the CAN bus line, ETACS-ECU, combination meter, or ASC-ECU.

PROBABLE CAUSES

- Damaged wiring harness and connectors
- Malfunction of ETACS-ECU
- Combination meter malfunction
- ASC-ECU malfunction

DIAGNOSIS**Required Special Tools:**

- MB991958 Scan Tool (M.U.T.-III Sub Assembly)
 - MB991824: Vehicle Communication Interface (V.C.I.)
 - MB991827 M.U.T.-III USB Cable
 - MB991910 M.U.T.-III Main Harness A

STEP 1. Using scan tool MB991958, diagnose the CAN bus lines.

Using scan tool MB991958, diagnose the CAN bus lines.

Q: Is the check result normal?

YES : Go to Step 2.

NO : Repair the CAN bus lines. (Refer to GROUP 54C – Troubleshooting [P.54C-15](#).) Then go to Step 7.

STEP 2. Scan tool diagnostic trouble code

Using scan tool, check the diagnostic trouble code for ASC system.

Q: Is any DTC set?

YES : Carry out the diagnosis for the DTC. (Refer to [P.35C-22.](#))

NO : Go to Step 3.

STEP 3. M.U.T.-III actuator test

Perform the following actuator tests from the combination meter system to check if the brake warning light is illuminated. (Refer to GROUP 54A –Combination Meter, Actuator Test Table [P.54A-89.](#))

- Item 07: Indicator1

Q: Is the check result normal?

YES : Go to Step 4.

NO : Carry out the diagnosis of the combination meter. (Refer to GROUP 54A –Combination Meter, Trouble Symptom Chart [P.54A-67.](#)) Then go to Step 7.

STEP 4. Scan tool diagnostic trouble code for other system

Using scan tool MB991958, check if diagnostic trouble code No. U0141 is set by the combination meter system.

Q: Is the DTC set?

YES : Diagnose the combination meter. (Refer to GROUP 54A –Combination Meter, Troubleshooting [P.54A-49.](#)) Then go to Step 7.

NO : Go to Step 5.

STEP 5. Scan tool diagnostic trouble code for other system

Using scan tool MB991958, check if diagnostic trouble code No. U0121 is set by ETACS system.

Q: Is the DTC set?

YES : Diagnose the ETACS-ECU. (Refer to GROUP 54A – ETACS, Troubleshooting [P.54A-655.](#)) Then go to Step 7.

NO : Go to Step 6.

STEP 6. Retest the system.

Q: Does the brake warning light turn ON and OFF normally?

YES : Intermittent malfunction. (Refer to GROUP 00 –How to Cope with Intermittent Malfunction [P.00-15.](#))

NO : Replace the hydraulic unit (incorporates in ASC-ECU).(Refer to [P.35C-298.](#)) Then go to Step 7.

STEP 7. Retest the system.

Q: Does the brake warning light turn ON and OFF normally?

YES : The procedure is complete.

NO : Return to Step 1.

Inspection Procedure 5: The ABS warning light remains illuminated even after the engine is started.

⚠ CAUTION

- If there is any problem in the CAN bus lines, an incorrect diagnostic trouble code may be set. Prior to this diagnosis, diagnose the CAN bus lines.
- Whenever the ECU is replaced, ensure that the CAN bus lines are normal.
- When the hydraulic unit (integrated with ASC-ECU) is replaced, always perform the calibration of steering wheel sensor, G and yaw rate sensor, brake fluid pressure sensor, cut valve, and inlet valve.(Refer to [P.35C-287](#), [P.35C-289](#), [P.35C-294](#), and [P.35C-295](#).)

SYSTEM OPERATION

- ASC-ECU sends the illumination signal of ABS warning light to the combination meter through ETACS-ECU via CAN communication.
- When the ignition switch is turned ON, ASC-ECU illuminates the ABS warning light via ETACS-ECU for approximately 3 seconds for the purpose of bulb check.

TECHNICAL DESCRIPTION (COMMENT)

In the case of this trouble symptom, there may be a malfunction to the CAN bus line, ETACS-ECU, combination meter, or ASC-ECU.

PROBABLE CAUSES

- Damaged wiring harness and connectors
- Malfunction of ETACS-ECU
- Combination meter malfunction
- ASC-ECU malfunction
- Control stop due to the low voltage

NOTE: Due to the abnormality in the supply voltage, the diagnostic trouble code may not be set even when the ABS warning light is illuminated.

DIAGNOSIS

Required Special Tools:

- MB991958 Scan Tool (M.U.T.-III Sub Assembly)
 - MB991824: Vehicle Communication Interface (V.C.I.)
 - MB991827 M.U.T.-III USB Cable
 - MB991910 M.U.T.-III Main Harness A

STEP 1. Using scan tool MB991958, diagnose the CAN bus lines.

Using scan tool MB991958, diagnose the CAN bus lines.

Q: Is the check result normal?

YES : Go to Step 2.

NO : Repair the CAN bus lines. (Refer to GROUP 54C – Troubleshooting [P.54C-15.](#)) Then go to Step 7.

STEP 2. Scan tool diagnostic trouble code

Using scan tool, check the diagnostic trouble code for ASC system.

Q: Is any DTC set?

YES : Carry out the diagnosis for the DTC. (Refer to [P.35C-22.](#))

NO : Go to Step 3.

STEP 3. Check of ASC-ECU power supply circuit

Refer to [P.35C-258.](#)

Q: Is the check result normal?

YES : Go to Step 4.

NO : Carry out the diagnosis of ASC-ECU power supply circuit system.(Refer to [P.35C-258.](#))

STEP 4. Scan tool diagnostic trouble code for other system

Using scan tool MB991958, check if diagnostic trouble code No. U0141 is set by the combination meter system.

Q: Is the DTC set?

YES : Diagnose the combination meter. (Refer to GROUP 54A –Combination Meter, Troubleshooting [P.54A-49.](#)) Then go to Step 7.

NO : Go to Step 5.

STEP 5. Scan tool diagnostic trouble code for other system

Using scan tool MB991958, check if diagnostic trouble code No. U0121 is set by ETACS system.

Q: Is the DTC set?

YES : Diagnose the ETACS-ECU. (Refer to GROUP 54A – ETACS, Troubleshooting [P.54A-646.](#)) Then go to Step 7.

NO : Go to Step 6.

STEP 6. Retest the system.**Q: Does the ABS warning light turn ON and OFF normally?****YES :** Intermittent malfunction. (Refer to GROUP 00 –How to Cope with Intermittent Malfunction [P.00-15.](#))**NO :** Replace the hydraulic unit (incorporates in ASC-ECU).(Refer to [P.35C-298.](#)) Then go to Step 7.**STEP 7. Retest the system.****Q: Does the ABS warning light turn ON and OFF normally?****YES :** The procedure is complete.**NO :** Return to Step 1.

Inspection Procedure 6: The ASC warning display stays ON even after the engine is started.

⚠ CAUTION

- Whenever the ECU is replaced, ensure that the CAN bus lines are normal.
- When the hydraulic unit (integrated with ASC-ECU) is replaced, always perform the calibration of steering wheel sensor, G and yaw rate sensor, brake fluid pressure sensor, cut valve, and inlet valve.(Refer to [P.35C-287](#), [P.35C-289](#), [P.35C-294](#), and [P.35C-295.](#))

SYSTEM OPERATION

ASC-ECU sends the illumination request signal of ASC warning display to the combination meter through ETACS-ECU via CAN communication.

TECHNICAL DESCRIPTION (COMMENT)

In the case of this trouble symptom, there may be a malfunction to the CAN bus line, ETACS-ECU, combination meter, or ASC-ECU.

PROBABLE CAUSES

- Damaged wiring harness and connectors
- Malfunction of ETACS-ECU
- Combination meter malfunction
- ASC-ECU malfunction
- Control stop due to the low voltage

NOTE: Due to the abnormality in the supply voltage, the diagnostic trouble code may not be set even when the ASC warning display is illuminated.

DIAGNOSIS

Required Special Tools:

- MB991958 Scan Tool (M.U.T.-III Sub Assembly)
 - MB991824: Vehicle Communication Interface (V.C.I.)
 - MB991827 M.U.T.-III USB Cable
 - MB991910 M.U.T.-III Main Harness A

STEP 1. Using scan tool MB991958, diagnose the CAN bus lines.

Using scan tool MB991958, diagnose the CAN bus lines.

Q: Is the check result normal?

YES : Go to Step 2.

NO : Repair the CAN bus lines. (Refer to GROUP 54C – Troubleshooting [P.54C-15.](#)) Then go to Step 7.

STEP 2. Scan tool diagnostic trouble code

Using scan tool, check the diagnostic trouble code for ASC system.

Q: Is any DTC set?

YES : Carry out the diagnosis for the DTC. (Refer to [P.35C-22.](#))

NO : Go to Step 3.

STEP 3. Check of ASC-ECU power supply circuit

Refer to [P.35C-258.](#)

Q: Is the check result normal?

YES : Go to Step 4.

NO : Carry out the diagnosis of ASC-ECU power supply circuit system.(Refer to [P.35C-258.](#))

STEP 4. Scan tool diagnostic trouble code for other system

Using scan tool MB991958, check if diagnostic trouble code No. U0141 is set by the combination meter system.

Q: Is the DTC set?

YES : Diagnose the combination meter. (Refer to GROUP 54A –Combination Meter, Troubleshooting [P.54A-49.](#)) Then go to Step 7.

NO : Go to Step 5.

STEP 5. Scan tool diagnostic trouble code for other system

Using scan tool MB991958, check if diagnostic trouble code No. U0121 is set by ETACS system.

Q: Is the DTC set?

YES : Diagnose the ETACS-ECU. (Refer to GROUP 54A – ETACS, Troubleshooting [P.54A-655.](#)) Then go to Step 7.

NO : Go to Step 6.

STEP 6. Retest the system.

Q: Does the ASC warning display turn ON and OFF normally?

YES : Intermittent malfunction. (Refer to GROUP 00 –How to Cope with Intermittent Malfunction P.00-15.)

NO : Replace the hydraulic unit (incorporates in ASC-ECU).(Refer to P.35C-298.) Then go to Step 7.

STEP 7. Retest the system.

Q: Does the ASC warning display turn ON and OFF normally?

YES : The procedure is complete.

NO : Return to Step 1.

Inspection Procedure 7: The ASC OFF display remains illuminated after the engine is started.

ASC OFF Switch Circuit

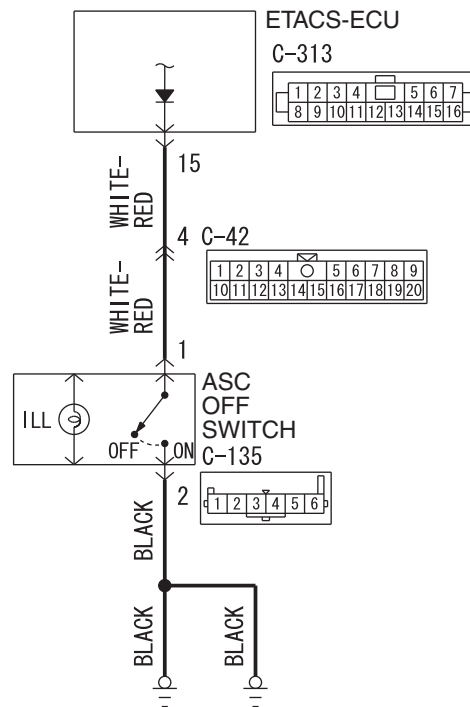

WAH35M014A

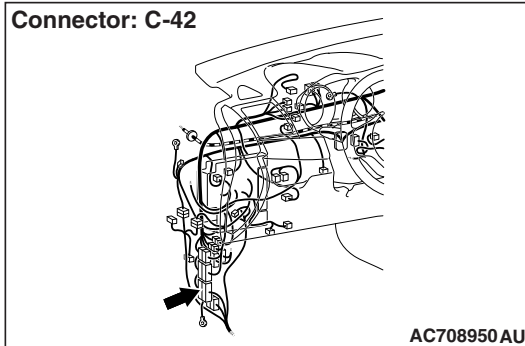
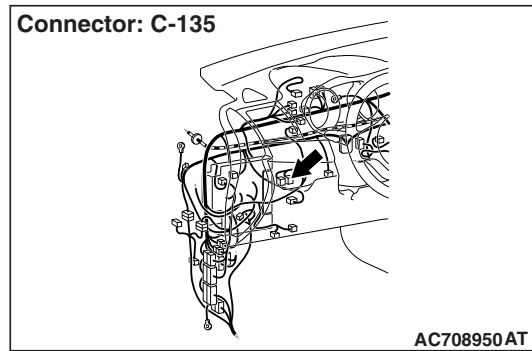
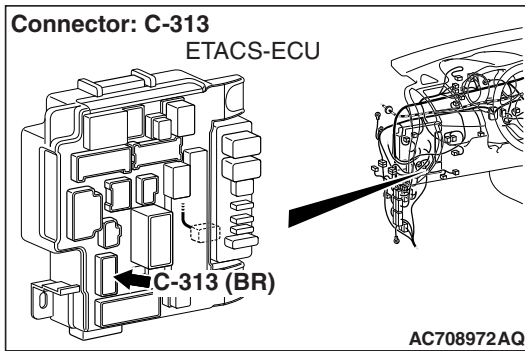

⚠ CAUTION

- Whenever the ECU is replaced, ensure that the CAN bus lines are normal.
- When the hydraulic unit (integrated with ASC-ECU) is replaced, always perform the calibration of steering wheel sensor, G and yaw rate sensor, brake fluid pressure sensor, cut valve, and inlet valve.(Refer to [P.35C-287](#), [P.35C-289](#), [P.35C-294](#), and [P.35C-295](#).)

SYSTEM OPERATION

- ASC-ECU sends the illumination request signal of ASC OFF display to the combination meter through ETACS-ECU via CAN communication.
- By the operation of ASC OFF switch, the ASC OFF display illuminates when the ASC function is stopped.
- When the ASC OFF switch is pressed shortly, the ASC system is turned OFF.

TECHNICAL DESCRIPTION (COMMENT)

In the case of this trouble symptom, there may be a short circuit to the ASC OFF switch circuit.

PROBABLE CAUSES

- Damaged wiring harness and connectors
- ASC OFF switch malfunction
- ETACS-ECU malfunction
- Combination meter malfunction
- ASC-ECU malfunction

DIAGNOSIS**Required Special Tools:**

- MB991958 Scan Tool (M.U.T.-III Sub Assembly)
 - MB991824: Vehicle Communication Interface (V.C.I.)
 - MB991827 M.U.T.-III USB Cable
 - MB991910 M.U.T.-III Main Harness A

STEP 1. Using scan tool MB991958, diagnose the CAN bus lines.

Using scan tool MB991958, diagnose the CAN bus lines.

Q: Is the check result normal?

YES : Go to Step 2.

NO : Repair the CAN bus lines. (Refer to GROUP 54C – Troubleshooting [P.54C-15.](#)) Then go to Step 9.

STEP 2. Scan tool diagnostic trouble code

Using scan tool, check the diagnostic trouble code for ASC system.

Q: Is any DTC set?

YES : Carry out the diagnosis for the DTC. (Refer to [P.35C-22.](#))

NO : Go to Step 3.

STEP 3. ASC OFF switch check

Refer to [P.35C-297.](#)

Q: Is the check result normal?

YES : Go to Step 4.

NO : Replace the ASC OFF switch (Refer to [P.35C-296.](#)) Then go to Step 9.

STEP 4. Connector check: C-313 ETACS-ECU connector, C-42 intermediate connector, C-135 ASC OFF switch connector**Q: Is the check result normal?**

YES : Go to Step 5.

NO : Repair the defective connector.

STEP 5. Wiring harness check between C-313 ETACS-ECU connector terminal No. 15 and C-135 ASC OFF switch connector terminal No. 1

- Short circuit check of the signal line circuit

Q: Is the check result normal?

YES : Go to Step 6.

NO : Repair the wiring harness between C-313 ETACS-ECU connector terminal No. 15 and C-119 ASC OFF switch connector terminal No. 1.

STEP 6. Scan tool diagnostic trouble code for other system

Using scan tool MB991958, check if diagnostic trouble code No. U0141 is set by the combination meter system.

Q: Is the DTC set?

YES : Diagnose the combination meter. (Refer to GROUP 54A –Combination Meter, Troubleshooting [P.54A-49.](#)) Then go to Step 9.

NO : Go to Step 7.

STEP 7. Scan tool diagnostic trouble code for other system

Using scan tool MB991958, check if diagnostic trouble code No. U0121 is set by ETACS system.

Q: Is the DTC set?

YES : Diagnose the ETACS-ECU (Refer to GROUP 54A – ETACS, Troubleshooting [P.54A-655.](#)) Then go to Step 8.

NO : Go to Step 8.

STEP 8. Retest the system.

Q: Does the ASC OFF display turn ON and OFF normally?

YES : Intermittent malfunction. (Refer to GROUP 00 –How to Cope with Intermittent Malfunction [P.00-15.](#))

NO : Replace the hydraulic unit (incorporates in ASC-ECU). (Refer to [P.35C-298.](#)) Then go to Step 9.

STEP 9. Retest the system.

Q: Does the ASC OFF display turn ON and OFF normally?

YES : The procedure is complete.

NO : Return to Step 1.

Inspection Procedure 8: After the ASC OFF switch is pressed to turn "OFF," the stability control/TCL cannot be cancelled.

ASC OFF Switch Circuit

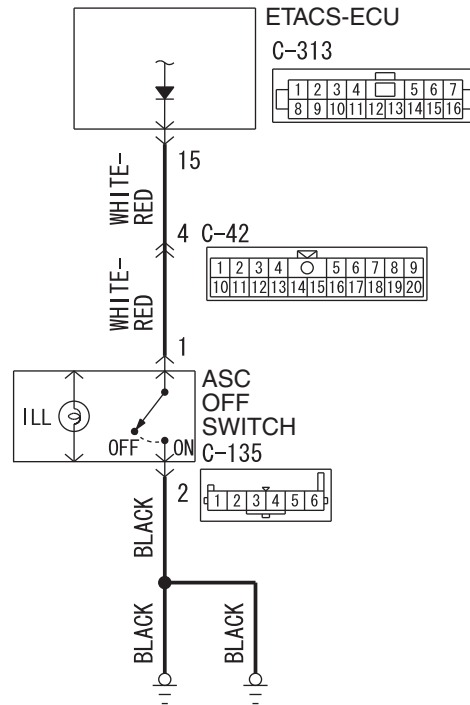

WAH35M014A

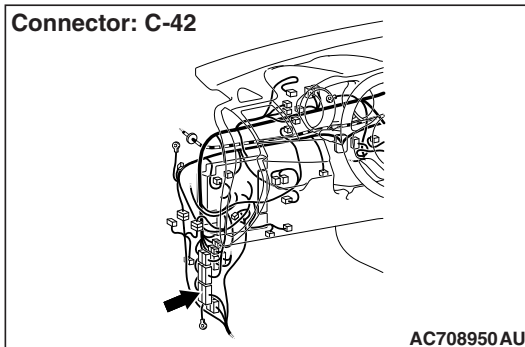
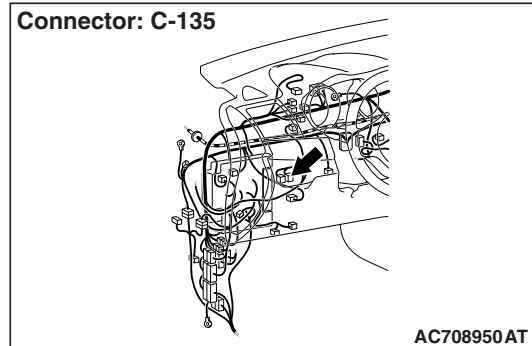
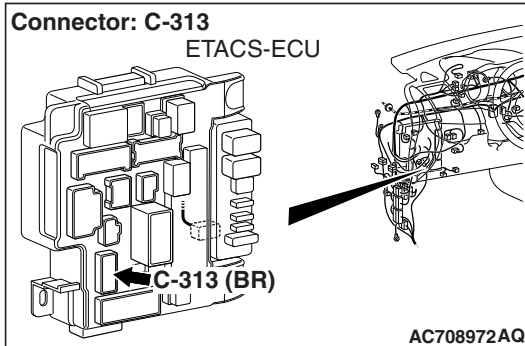

⚠ CAUTION

- If there is any problem in the CAN bus lines, an incorrect diagnostic trouble code may be set. Prior to this diagnosis, diagnose the CAN bus lines.
- Whenever the ECU is replaced, ensure that the CAN bus lines are normal.

SYSTEM OPERATION

- The ETACS-ECU terminal No. 15 is grounded when the ASC OFF switch is pressed. The ON/OFF status of ASC OFF switch is sent from ETACS-ECU to ASC-ECU via CAN bus line.
- When the ASC OFF switch is pressed shortly, the ASC system is turned OFF.
- When the ASC OFF switch is pressed and held for 15 seconds or more, the ASC OFF indicator light is turned off, and the ASC system is turned ON.

TECHNICAL DESCRIPTION (COMMENT)

In the case of this trouble symptom, there may be an open and short circuit to the ASC OFF switch circuit.

PROBABLE CAUSES

- Damaged wiring harness and connectors
- ASC OFF switch malfunction
- ETACS-ECU malfunction
- Combination meter malfunction

DIAGNOSIS

Required Special Tools:

- MB991958 Scan Tool (M.U.T.-III Sub Assembly)
 - MB991824: Vehicle Communication Interface (V.C.I.)
 - MB991827 M.U.T.-III USB Cable
 - MB991910 M.U.T.-III Main Harness A

STEP 1. Using scan tool MB991958, diagnose the CAN bus lines.

Using scan tool MB991958, diagnose the CAN bus lines.

Q: Is the check result normal?

YES : Go to Step 2.

NO : Repair the CAN bus lines. (Refer to GROUP 54C – Troubleshooting [P.54C-15.](#)) After repairing the CAN bus line, go to Step 8.

STEP 2. ASC OFF switch check

Refer to [P.35C-297.](#)

Q: Is the check result normal?

YES : Go to Step 3.

NO : Replace the ASC OFF switch. (Refer to [P.35C-296.](#)) Then, go to Step 8.

STEP 3. Connector check: C-313 ETACS-ECU connector, C-42 intermediate connector, C-135 ASC OFF switch connector

Q: Is the check result normal?

YES : Go to Step 4.

NO : Repair the defective connector.

STEP 4. Wiring harness check between C-313 ETACS-ECU connector terminal No. 15 and C-135 ASC OFF switch connector terminal No. 1

- Check the power supply circuit for open and short circuit.

Q: Is the check result normal?

YES : Go to Step 5.

NO : Repair the wiring harness between C-313 ETACS-ECU connector terminal No. 15 and C-135 ASC OFF switch connector terminal No. 1.

STEP 5. Wiring harness check between C-135 ASC OFF switch connector terminal No. 2 and the body ground

- Open circuit check of the ground circuit

Q: Is the check result normal?

YES : Go to Step 6.

NO : Repair the wiring harness between C-135 ASC OFF switch connector terminal No. 2 and the body ground.

STEP 6. Retest the system.

Q: Does ASC turn ON and OFF normally using the ASC OFF switch?

YES : Intermittent malfunction. (Refer to GROUP 00 –How to Cope with Intermittent Malfunction [P.00-15](#).)

NO : Replace the ETACS-ECU. (Refer to GROUP 54A – ETACS-ECU [P.54A-742](#).) Then, go to Step 7.

STEP 7. Retest the system.

Q: Does ASC turn ON and OFF normally using the ASC OFF switch?

YES : The procedure is complete.

NO : Replace the combination meter. (Refer to GROUP 54A –Combination Meter [P.54A-110](#).) Then, go to Step 8.

STEP 8. Retest the system.

Q: Does ASC turn ON and OFF normally using the ASC OFF switch?

YES : The procedure is complete.

NO : Return to Step 1.

Inspection Procedure 9: Abnormality in brake operation

⚠ CAUTION

- If there is any problem in the CAN bus lines, an incorrect diagnostic trouble code may be set. Prior to this diagnosis, diagnose the CAN bus lines.
- Whenever the ECU is replaced, ensure that the CAN bus lines are normal.
- When the hydraulic unit (integrated with ASC-ECU) is replaced, always perform the calibration of steering wheel sensor, G and yaw rate sensor, brake fluid pressure sensor, cut valve, and inlet valve.(Refer to [P.35C-287](#), [P.35C-289](#), [P.35C-294](#), and [P.35C-295](#).)

TECHNICAL DESCRIPTION (COMMENT)

Although it is difficult to determine the trouble cause since it depends on the running status and road surface condition, a malfunction of hydraulic circuit may be present if no diagnostic trouble code is detected.

PROBABLE CAUSES

- Malfunction of hydraulic unit (integrated with ABS-ECU)
- Malfunction of hydraulic circuit
- Malfunction of brake assembly
- Malfunction of brake booster
- Malfunction of master cylinder assembly

DIAGNOSIS**Required Special Tools:**

- MB991958 Scan Tool (M.U.T.-III Sub Assembly)
 - MB991824: Vehicle Communication Interface (V.C.I.)
 - MB991827 M.U.T.-III USB Cable
 - MB991910 M.U.T.-III Main Harness A

STEP 1. Check the DTC.

Using scan tool, check the diagnostic trouble code for ASC system. (Refer to [P.35C-22](#).)

Q: Is the check result normal?

YES : Go to Step 2.

NO : Carry out the diagnosis for DTC. (Refer to [P.35C-22](#).)

STEP 2. Hydraulic unit (integrated with ASC-ECU) check

Check that the brake tube is correctly mounted to the hydraulic unit (integrated with ASC-ECU). (Refer to [P.35C-284](#).)

Q: Is the check result normal?

YES : Go to Step 3.

NO : Connect the brake tubes correctly, and repair or replace the external brake lines of the hydraulic unit (integrated with ASC-ECU).

STEP 3. Brake operation check

Perform the following checks.

- Brake pedal check (Refer to GROUP 35A –On-vehicle Service, Brake Pedal Check [P.35A-12.](#))
- Brake booster check (Refer to GROUP 35A –On-vehicle Service, Brake Booster Operation Check [P.35A-15.](#))
- Check valve check (Refer to GROUP 35A –On-vehicle Service, Check Valve Operation Check [P.35A-16.](#))

Q: Can any fault be found with the brake operation?

YES : Check the brake-related parts, and repair if necessary. Then, go to Step 4.

NO : Go to Step 4.

STEP 4. Hydraulic unit check

Perform the following actuator tests. (Refer to [P.35C-278.](#))

- Item 01: FL wheel ABS drive
- Item 02: FR wheel ABS drive
- Item 03: RL wheel ABS drive
- Item 04: RR wheel ABS drive
- Item 05: FL wheel TCL drive
- Item 06: FR wheel TCL drive
- Item 07: RL wheel TCL drive
- Item 08: RR wheel TCL drive

Q: Is the check result normal?

YES : The procedure is complete.

NO : Replace the hydraulic unit (incorporates in ASC-ECU).(Refer to [P.35C-298.](#))

Inspection Procedure 10: Skid control/TCL does not operate.

⚠ CAUTION

- If there is any problem in the CAN bus lines, an incorrect diagnostic trouble code may be set. Prior to this diagnosis, diagnose the CAN bus lines.
- Whenever the ECU is replaced, ensure that the CAN bus lines are normal.
- When the hydraulic unit (integrated with ASC-ECU) is replaced, always perform the calibration of steering wheel sensor, G and yaw rate sensor, brake fluid pressure sensor, cut valve, and inlet valve.(Refer to [P.35C-287](#), [P.35C-289](#), [P.35C-294](#), and [P.35C-295.](#))

TECHNICAL DESCRIPTION (COMMENT)

In case of this trouble symptom, the operation of skid control/TCL system may be disabled. In this case, a diagnostic trouble code may be set by the skid control/TCL system using the scan tool.

PROBABLE CAUSES

- Low battery output
- Wiring harness or connector failure of CAN bus line
- ASC-ECU malfunction
- Different ETACS-ECU, abnormal variant coding information
- Abnormal engine coding data

DIAGNOSIS

Required Special Tools:

- MB991958: Scan Tool (M.U.T.-III Sub Assembly)
 - MB991824: Vehicle Communication Interface (V.C.I.)
 - MB991827: M.U.T.-III USB Cable
 - MB991910: M.U.T.-III Main Harness A

STEP 1. Check the DTC.

Using scan tool, check the diagnostic trouble code for ASC system. (Refer to [P.35C-22.](#))

Q: Is the check result normal?

YES : Go to Step 2.

NO : Carry out the diagnosis for the DTC. (Refer to [P.35C-22.](#))

STEP 2. Engine control module coding data check

Using the scan tool, check if there is any abnormality to the following coding data stored in the engine control module. (Refer to GROUP 00 –Coding Table [P.00-26.](#))

A.S.C.

OK: Present

Q: Is the check result normal?

YES : Go to Step 3.

NO : Replace the engine control module. (Refer to GROUP 13A –Engine Control Module [P.13A-888.](#)) Then go to Step 4.

STEP 3. Hydraulic unit (integrated with ASC-ECU) check

Check that the brake tube is correctly mounted to the hydraulic unit (integrated with ASC-ECU). (Refer to [P.54A-646.](#))

Q: Is the check result normal?

YES : Replace the hydraulic unit (incorporates in ASC-ECU).(Refer to [P.35C-284.](#)) Then go to Step 4.

NO : Connect the brake tubes correctly, and repair or replace the external brake lines of the hydraulic unit (integrated with ASC-ECU).

STEP 4. Operation check

Q: Does the skid control/TCL operate normally?

YES : The procedure is complete.

NO : Check the brake related components other than the skid control/TCL.

Inspection Procedure 11: ASC-ECU power supply circuit system

ASC-ECU Power Supply Circuit

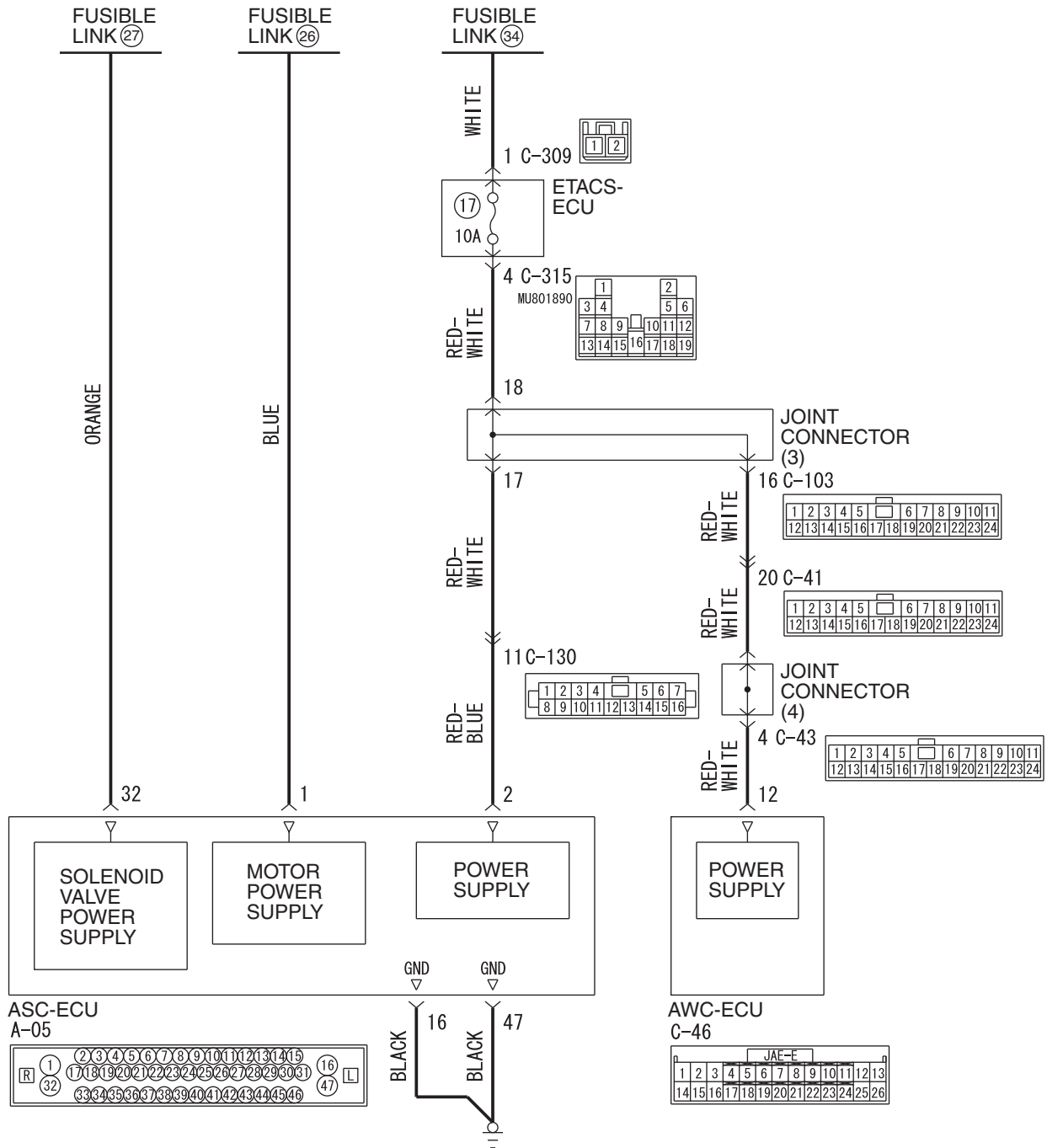

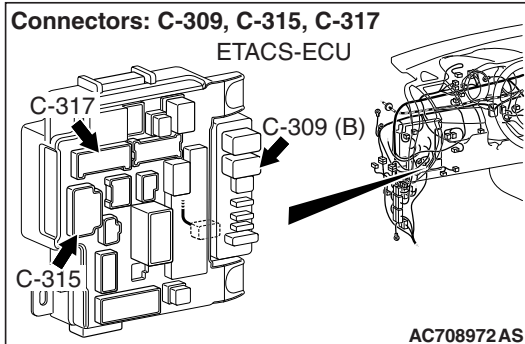
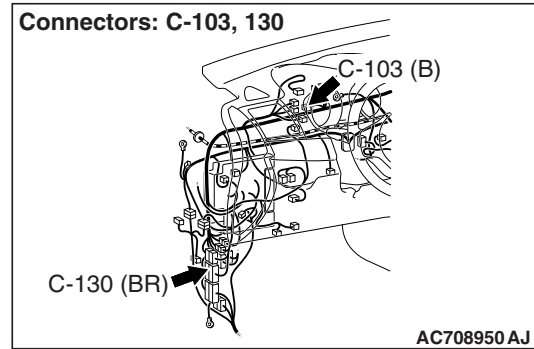
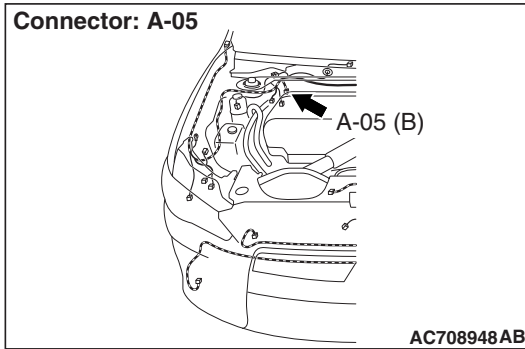

⚠ CAUTION

- When the ASC-ECU power supply voltage becomes 9.7 ± 0.3 V or less, the ABS warning light, ASC warning display, and ASC OFF display illuminate, and the ABS, stability control, and TCL controls are prohibited.
- If the battery terminal is not tightened properly, a dump surge may occur and the power supply voltage may become abnormally high for a short period of time.
- If there is any problem in the CAN bus lines, an incorrect diagnostic trouble code may be set. Prior to this diagnosis, diagnose the CAN bus lines.
- Whenever the ECU is replaced, ensure that the CAN bus lines are normal.
- When the hydraulic unit (integrated with ASC-ECU) is replaced, always perform the calibration of steering wheel sensor, G and yaw rate sensor, brake fluid pressure sensor, cut valve, and inlet valve. (Refer to [P.35C-287](#), [P.35C-289](#), [P.35C-294](#), and [P.35C-295](#).)

SYSTEM OPERATION

- ASC-ECU contains the power supply circuit (terminal No. 32) for the solenoid valve. The solenoid valve is energized by the valve relay, which is incorporated in ASC-ECU.
- ASC-ECU contains the power supply circuit (terminal No. 1) for the pump motor. The pump motor is energized by the motor relay, which is incorporated in ASC-ECU.
- ASC-ECU contains the power supply circuit (terminal No. 2) for ASC-ECU, and the power is supplied from the fusible link No. 34 through the multi-purpose fuse No. 17.
- If a malfunction occurs in the ASC-ECU power supply, the communication with scan tool becomes unavailable.

PROBABLE CAUSES

- Damaged wiring harness and connectors
- Malfunction of fuse or fusible link
- Improper tightening of battery terminal
- Improper tightening of grounding bolt
- Battery failure
- Charging system failed
- ASC-ECU malfunction

DIAGNOSIS**Required Special Tools:**

- MB991958 Scan Tool (M.U.T.-III Sub Assembly)
 - MB991824: Vehicle Communication Interface (V.C.I.)
 - MB991827 M.U.T.-III USB Cable
 - MB991910 M.U.T.-III Main Harness A
- MB991997: ASC check harness

STEP 1. Battery check

Refer to GROUP 54A –Battery Test [P.54A-9](#).

Q: Is the battery in good condition?

YES : Go to Step 3.

NO : Charge or replace the battery. Then, go to Step 2.

STEP 2. Charging system check

Refer to GROUP 16 –Output Current Test [P.16-8](#).

Q: Is the charging system in good condition?

YES : Go to Step 3.

NO : Repair or replace the charging system component(s).

STEP 3. Connector check: A-05 ASC-ECU connector**Q: Is the check result normal?**

YES : Go to Step 4.

NO : Repair the defective connector.

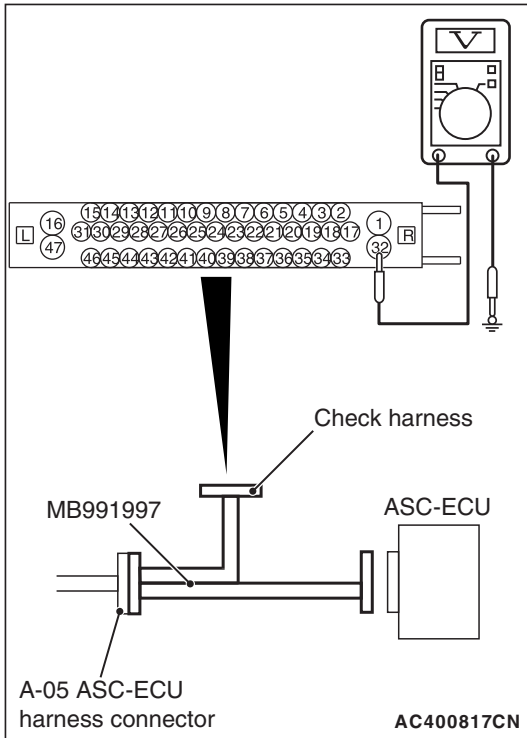

STEP 4. Voltage measurement at A-05 ASC-ECU connector

- (1) Disconnect the connector, connect the ASC check harness (Special tool: MB991997) to the wiring harness-side connector, and measure the voltage at the special tool connector side.

NOTE: Do not connect the special tool to ASC-ECU.

- (2) Measure the voltage between the terminal No. 32 and the body ground.

OK: Battery positive voltage

Q: Is the check result normal?

YES : Go to Step 7.

NO : Go to Step 5.

STEP 5. Fusible link check: Check the fusible link No. 27.

Q: Is the check result normal?

YES : An open circuit may be present in the power supply circuit. Repair the wiring harness between A-05 ASC-ECU connector terminal No. 32 and the fusible link No. 27.

NO : Go to Step 6.

STEP 6. Wiring harness check between A-05 ASC-ECU connector and fusible link No. 27.

- (1) Disconnect ASC-ECU connector A-05.
- (2) Remove fusible link No. 27.
- (3) Check the continuity (short to ground) between A-05 ASC-ECU connector terminal No. 32 and the ground.

OK: No continuity

Q: Is the check result normal?

YES : Replace the fusible link No.27.

NO : Short circuit may be present in the power supply circuit. Repair the wiring harness between A-05 ASC-ECU connector terminal No. 32 and fusible link No. 27.

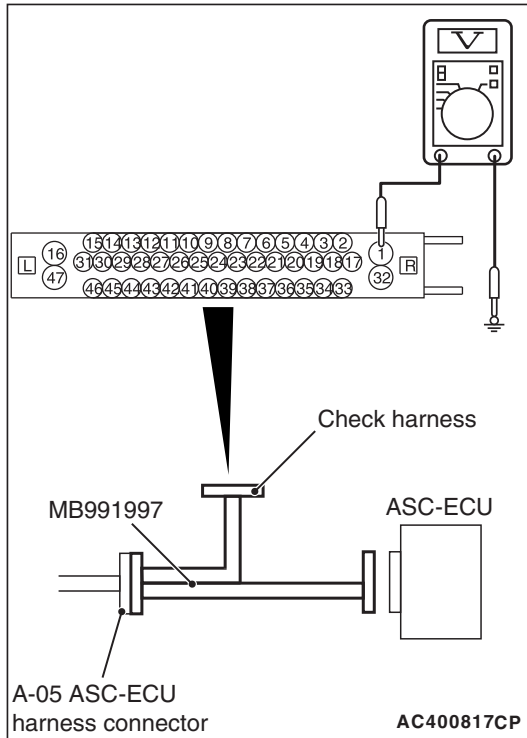
**STEP 7. Voltage measurement at A-05 ASC-ECU connector**

- (1) Disconnect the connector, connect the ASC check harness (Special tool: MB991997) to the wiring harness-side connector, and measure the voltage at the special tool connector side.

NOTE: Do not connect the special tool to ASC-ECU.

- (2) Measure the voltage between the terminal No. 1 and the body ground.

OK: Battery positive voltage

Q: Is the check result normal?

YES : Go to Step 10.

NO : Go to Step 8.

STEP 8. Fusible link check: Check the fusible link No.26.

Visually check for open circuit in the fusible link No.26.

Q: Is the check result normal?

YES : An open circuit may be present in the pump motor power supply circuit. Repair the wiring harness between A-05 ASC-ECU connector terminal No. 1 and the fusible link No. 26.

NO : Go to Step 9.

STEP 9. Wiring harness check between A-05 ASC-ECU connector and fusible link No. 26.

- (1) Disconnect ASC-ECU connector A-05.
- (2) Remove fusible link No. 26.
- (3) Check the continuity (short to ground) between A-05 ASC-ECU connector terminal No. 1 and the ground.

OK: No continuity

Q: Is the check result normal?

YES : Replace the fusible link No.26.

NO : Short circuit may be present in the power supply circuit. Repair the wiring harness between A-05 ASC-ECU connector terminal No. 1 and fusible link No. 26.

STEP 10. Check of fuse No. 17 and fusible link No. 34

Visually check for open circuit in the fuse No. 17 and the fusible link No. 34.

Q: Is the check result normal?

YES : Go to Step 16.

NO : Go to Step 11.

STEP 11. Connector check: C-41 intermediate connector, C-43 joint connector, C-46 ETACS-ECU connector, C-103 joint connector, C-130 intermediate connector, C-309 ETACS-ECU connector and C-315 ETACS-ECU connector

Q: Is the check result normal?

YES : Go to Step 12.

NO : Repair the connector. Then, replace fuse No. 17 or fusible link No. 34.

STEP 12. Wiring harness check between C-309 ETACS-ECU connector and fusible link No. 34.

- (1) Remove fusible link No. 34.
- (2) Disconnect ETACS-ECU connector C-309, and measure at the wiring harness side.
- (3) Check the continuity (short to ground) between terminal No. 1 and the ground.

OK: No continuity

Q: Is the check result normal?

YES : Go to Step 13.

NO : Repair the wiring harness between C-309 ETACS-ECU connector terminal No. 1 and fusible link No. 34. Then, replace fuse No. 17 or fusible link No. 34.

STEP 13. Wiring harness check between C-315 ETACS-ECU connector and C-103 joint connector.

- (1) Disconnect the C-103 joint connector.
- (2) Disconnect ETACS-ECU connector C-315, and measure at the wiring harness side.
- (3) Check the continuity (short to ground) between terminal No. 4 and the ground.

OK: No continuity

Q: Is the check result normal?

YES : Go to Step 14.

NO : Repair the wiring harness between C-315 ETACS-ECU connector terminal No. 4 and C-103 joint connector terminal No.18. Then, replace fuse No. 17 or fusible link No. 34.

STEP 14. Wiring harness check between the C-103 joint connector and the C-46 AWC-ECU connector.

- (1) Disconnect the C-46 AWC-ECU connector.
- (2) Disconnect the C-103 joint connector, and measure at the wiring harness side.
- (3) Check the continuity (short to ground) between terminal No. 16 and the ground.

OK: No continuity

Q: Is the check result normal?

YES : Go to Step 15.

NO : Repair the wiring harness between C-103 joint connector terminal No.16 and C-46 AWC-ECU connector terminal No.12. Then, replace fuse No. 17 or fusible link No. 34.

STEP 15. Wiring harness check between the C-103 joint connector and the A-05 ASC-ECU connector.

- (1) Disconnect ASC-ECU connector A-05.
- (2) Disconnect the C-103 joint connector, and measure at the wiring harness side.
- (3) Check the continuity (short to ground) between terminal No.17 and the ground.

OK: No continuity

Q: Is the check result normal?

YES : Replace the fuse No. 17 or the fusible link No. 34. Then, go to Step 20.

NO : Repair the wiring harness between C-103 joint connector terminal No.17 and A-05 ASC-ECU connector terminal No.2. Then, replace fuse No. 17 or fusible link No. 34.

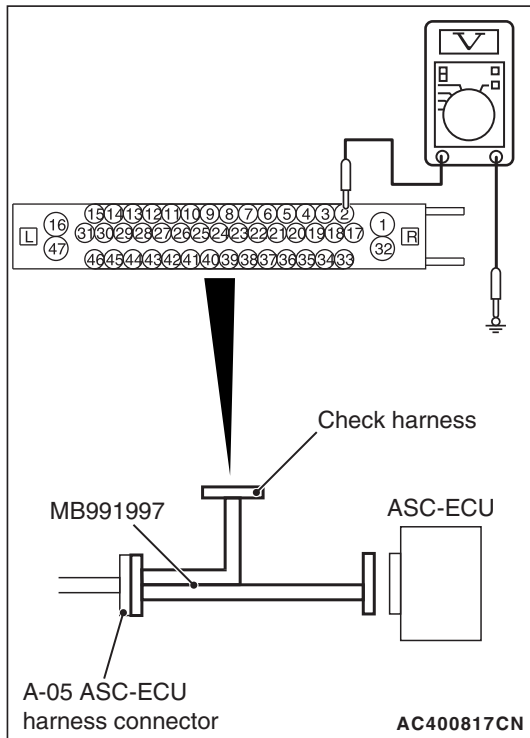

STEP 16. Voltage measurement at A-05 ASC-ECU connector

- (1) Disconnect the connector, connect the ASC check harness (Special tool: MB991997) to the wiring harness-side connector, and measure the voltage at the special tool connector side.

NOTE: Do not connect the special tool to ASC-ECU.

- (2) Measure the voltage between the terminal No. 2 and the body ground.

OK: Battery positive voltage

Q: Is the check result normal?

YES : Go to Step 20.

NO : Go to Step 17.

STEP 17. Measure the voltage at the C-309 ETACS-ECU connector.

- (1) Disconnect the connector, and measure at the wiring harness-side connector.
- (2) Measure the voltage between the terminal No. 1 and the body ground.

OK: Battery positive voltage

Q: Is the check result normal?

YES : Go to Step 18.

NO : Repair the wiring harness between C-309 ETACS-ECU connector terminal No. 1 and the fusible link No. 34.

STEP 18. Measure the voltage at the C-315 ETACS-ECU connector.

- (1) Without disconnecting the connector, measure by backprobing.
- (2) Measure the voltage between the terminal No. 4 and the body ground.

OK: Battery positive voltage

Q: Is the check result normal?

YES : Go to Step 20.

NO : Go to Step 19.

STEP 19. Wiring harness check between A-05 ASC-ECU connector terminal No. 2 and C-315 ETACS-ECU connector terminal No. 4

- Check for open circuit.

Q: Is the check result normal?**YES** : Go to Step 20.**NO** : Repair the wiring harness.**STEP 20. Resistance measurement at A-05 ASC-ECU connector**

- (1) Disconnect the connector, connect the ASC check harness (Special tool: MB991997) to the wiring harness-side connector, and measure the voltage at the special tool connector side.

NOTE: Do not connect the special tool to ASC-ECU.

- (2) Measure the resistance between the terminal No. 16 and the body ground as well as between the terminal No. 47 and the body ground.

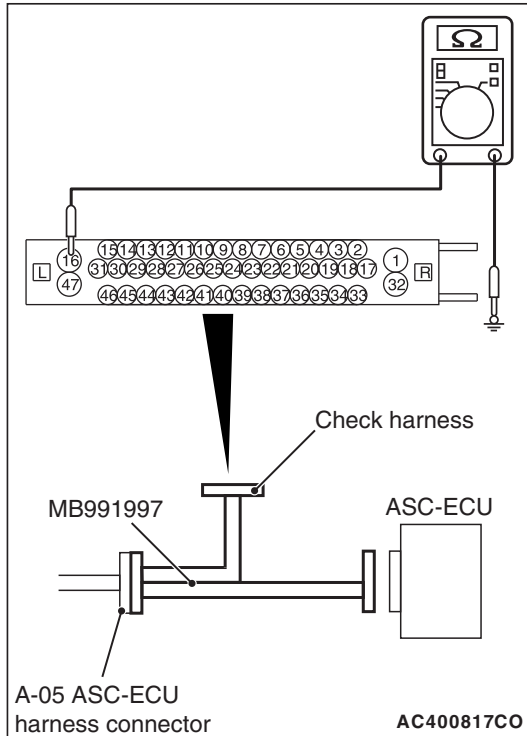
OK: Continuity exists (2 Ω or less)**Q: Is the check result normal?****YES** : Go to Step 21.**NO** : Repair the wiring harness.**STEP 21. Retest the system.****Q: Is the communication with scan tool MB991958 possible?****YES** : Intermittent malfunction. (Refer to GROUP 00 –How to Cope with Intermittent Malfunction [P.00-15.](#))**NO** : Check that the scan tool connection cable is properly connected, and that the V.C.I. switch is turned ON. Then, replace the hydraulic unit (integrated with ASC-ECU).(Refer to [P.35C-298.](#)) Then go to Step 22.**STEP 22. Retest the system.****Q: Is the communication with scan tool MB991958 possible?****YES** : Return to Step 1.**NO** : This diagnosis is complete.

Inspection Procedure 12: ABS/skid control/TCL operates too frequently.

 **CAUTION**

- If there is any problem in the CAN bus lines, an incorrect diagnostic trouble code may be set. Prior to this diagnosis, diagnose the CAN bus lines.
- Whenever the ECU is replaced, ensure that the CAN bus lines are normal.

COMMENTS ON TROUBLE SYMPTOM

- Although it is difficult to determine the trouble cause since it depends on the running status and road surface condition, a malfunction of hydraulic circuit may be present if no diagnostic trouble code is detected.
- If a wheel or tire of other than the genuine specified size is mounted, the ABS/skid control/TCL may be activated prematurely.
- If non-genuine braking device or non-genuine impact reducing device is mounted, the ABS/skid control/TCL may be activated prematurely.

PROBABLE CAUSES

- Installation of wheel or tire other than genuine specified size
- Tire pressure abnormality
- Tire wear and deterioration
- Installation of non-genuine braking device or non-genuine impact reducing device
- Wheel alignment abnormality
- Malfunction of brake-related components
- Malfunction of wheel speed sensor
- Malfunction of G and yaw rate sensor
- Malfunction of steering wheel sensor
- Malfunction of hydraulic unit (integrated with ASC-ECU)
- Malfunction of hydraulic circuit
- External noise interference

DIAGNOSIS

Required Special Tools:

- MB991958 Scan Tool (M.U.T.-III Sub Assembly)
 - MB991824: Vehicle Communication Interface (V.C.I.)
 - MB991827 M.U.T.-III USB Cable
 - MB991910 M.U.T.-III Main Harness A
- MB991997: ASC check harness

STEP 1. Check of wheels and tires

Perform the following checks.

- Check of wheel and tire size
- Tire wear and deterioration
- Tire pressure check

NOTE: For the tire pressure, refer to the tire pressure label attached to the lower section of driver's side door striker.

Q: Is the check result normal?

YES : Go to Step 2.

NO : Correct the wheels and tires. Then go to Step 9.

STEP 2. Check the DTC.

Using scan tool, check the diagnostic trouble code for ASC system. (Refer to [P.35C-22.](#))

Q: Is the check result normal?

YES : Go to Step 3.

NO : Carry out the diagnosis for the DTC. (Refer to [P.35C-22.](#)) Then go to Step 9.

STEP 3. Check of brake-related components other than hydraulic unit (integrated with ASC-ECU)

Perform the following checks, and also check that no non-genuine parts are installed.

- Brake pad check (Refer to GROUP 35A –On-vehicle Service, Brake Pad Check [P.35A-18.](#))
- Brake disc runout check (Refer to GROUP 35A –On-vehicle Service, Brake Disc Rotor Check [P.35A-21.](#))
- Brake drag force check (Refer to GROUP 35A –On-vehicle Service, Brake Drag Force Check [P.35A-23.](#))

Q: Is the check result normal?

YES : Go to Step 4.

NO : Repair or replace the trouble spot. Then go to Step 9.

STEP 4. Wheel alignment check

Perform the following checks, and also check that no non-genuine parts are installed.

- Front wheel alignment check (Refer to GROUP 33 – On-vehicle Service, Front Wheel Alignment Check and Adjustment [P.33-8.](#))
- Rear wheel alignment check (Refer to GROUP 34 – On-vehicle Service, Rear Wheel Alignment Check and Adjustment [P.34-9.](#))

Q: Is the check result normal?

YES : Go to Step 5.

NO : Repair or replace the trouble spot. Then go to Step 9.

STEP 5. Check of wheel speed sensor

Check for the presence of non-genuine electronic components and wiring harness of non-genuine electronic components to near the wheel speed sensor (wheel speed detecting section and wiring harness section). (Refer to [P.35C-300.](#))

Q: Is the check result normal?

YES : Go to Step 6.

NO : Remove the non-genuine electronic components and wiring harness of non-genuine electronic components. Then go to Step 9.

STEP 6. Scan tool service data

Check the following service data. (Refer to [P.35C-276.](#))

- Item 01: FL wheel speed sensor
- Item 02: FR wheel speed sensor
- Item 03: RL wheel speed sensor
- Item 04: RR wheel speed sensor
- Item 08: Lateral G sensor
- Item 10: Master cylinder pressure
- Item 11: Steering angle
- Item 12: Yaw rate sensor
- Item 129: FL wheel cylinder pressure
- Item 130: FR wheel cylinder pressure
- Item 131: RL wheel cylinder pressure
- Item 132: RR wheel cylinder pressure

Q: Is the check result normal?

YES : Go to Step 7.

NO (Abnormality of items 01 to 04) : Check the installation status of corresponding wheel speed sensor. (Refer to [P.35C-300.](#))

NO (Abnormality of items 08, 12) : Check the installation status of G and yaw rate sensor. (Refer to [P.35C-304.](#))

NO (Abnormality of item 11) : Check the installation status of steering wheel sensor. (Refer to [P.35C-305.](#))

NO (Abnormality of items 10, 129 to 132) : Replace the hydraulic unit (incorporates in ASC-ECU).(Refer to [P.35C-298.](#))

STEP 7. Hydraulic unit check

Perform the following actuator tests, and check that the operation is normal. (Refer to [P.35C-276.](#))

- Item 01: FL wheel ABS drive
- Item 02: FR wheel ABS drive
- Item 03: RL wheel ABS drive
- Item 04: RR wheel ABS drive
- Item 05: FL wheel TCL drive
- Item 06: FR wheel TCL drive
- Item 07: RL wheel TCL drive
- Item 08: RR wheel TCL drive

Q: Is the check result normal?

YES : Go to Step 8.

NO : Replace the hydraulic unit (incorporates in ASC-ECU).(Refer to [P.35C-298.](#)) Then go to Step 9.

STEP 8. Operation check of ABS/skid control/TCL**Q: Is the check result normal?**

YES : Intermittent malfunction. (Refer to GROUP 00 –How to Cope with Intermittent Malfunction [P.00-15.](#))

NO : Replace the hydraulic unit (incorporates in ASC-ECU).(Refer to [P.35C-298.](#)) Then go to Step 9.

STEP 9. Operation check of ABS/skid control/TCL**Q: Is the check result normal?**

YES : The procedure is complete.

NO : Return to Step 1.

Inspection Procedure 13: Steering wheel sensor power supply circuit system

Steering Wheel Sensor Power Supply Circuit

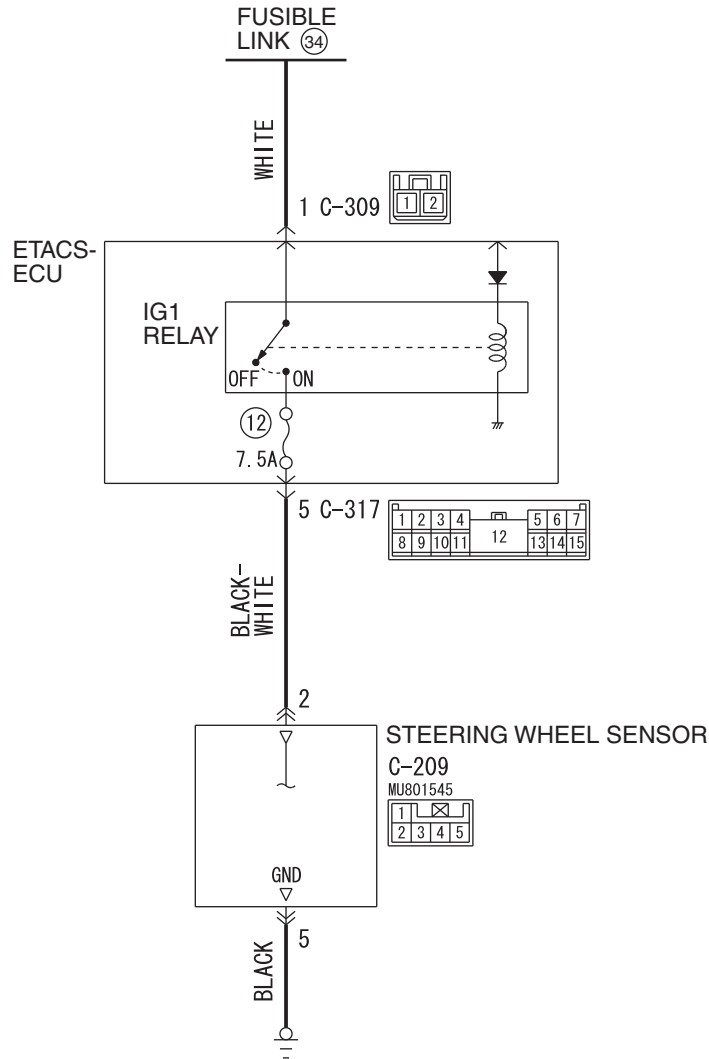

AC902052

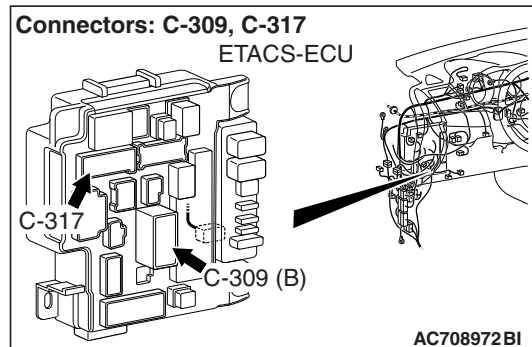
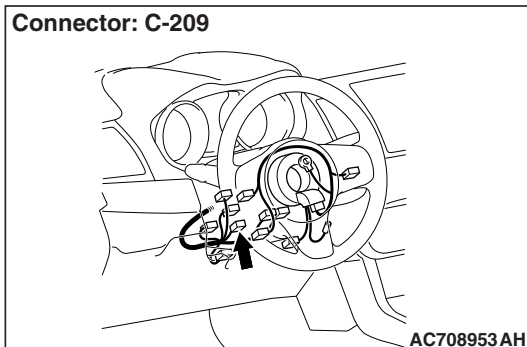

⚠ CAUTION

- If there is any problem in the CAN bus lines, an incorrect diagnostic trouble code may be set. Prior to this diagnosis, diagnose the CAN bus lines (Refer to GROUP 54C, Trouble code diagnosis P.54C-15).
- Whenever ECU is replaced, ensure that the CAN bus lines are normal.
- When the steering wheel sensor is replaced, always carry out calibration to make ASC-ECU learn the neutral point (Refer to P.35C-289).

OPERATION

- Steering wheel sensor contains the power supply circuit (terminal No.2) for Steering wheel sensor. The power is supplied from the ETACS-ECU (terminal No.5). The power is supplied from the fusible link No.33 through the multi-purpose fuse No.12.
- When malfunction occurs in Steering wheel sensor power supply, the communication with scan tool becomes unavailable.

PROBABLE CAUSES

- Damaged wiring harness and connectors
- Fuse and fusible link malfunction
- Improper tightening of battery terminal
- Battery failure
- Charging system failed
- Steering wheel sensor malfunction

DIAGNOSIS**Required Special Tools:**

- MB991958: Scan Tool (M.U.T.-III Sub Assembly)
 - MB991824: Vehicle Communication Interface (V.C.I.)
 - MB991827: M.U.T.-III USB Cable
 - MB991910: M.U.T.-III Main Harness A
- MB991997: ASC check harness

STEP 1. Connector check: C-209 steering wheel sensor connector**Q: Is the check result normal?****YES** : Go to Step 2.**NO** : Repair the damaged connector.

STEP 2. Resistance measurement at C-209 steering wheel sensor connector.

- (1) Disconnect C-209 steering wheel sensor connector and measure the resistance available at the wiring harness side of the connector.
- (2) Check the continuity between C-209 steering wheel sensor connector terminal No.5 and body ground.

OK: Continuity exists (2 Ω or less)

Q: Is the check result normal?

YES : Go to Step 4.

NO : Go to Step 3.

STEP 3. Check the wiring harness between C-209 steering wheel sensor connector terminal No.5 and the body ground.

- Check the ground wires for open circuit.

Q: Is the check result normal?

YES : If a trouble is solved, it is determined that there is an intermittent malfunction such as poor engaged connector(s) or open circuit (Refer to GROUP 00 – How to Cope with Intermittent Malfunction [P.00-15](#)).

NO : Repair the wiring harness.

STEP 4. Connector check: C-309 ETACS-ECU connector, C-317 ETACS-ECU connector

Q: Is the check result normal?

YES : Go to Step 5.

NO : Repair the damaged connector.

STEP 5. Voltage measurement at C-309 ETACS-ECU connector

- (1) Disconnect C-306 ETACS-ECU connector and measure the voltage available at the wiring harness side of the connector.
- (2) Measure the voltage between C-309 ETACS-ECU connector terminal No.1 and body ground.

OK: Battery positive voltage

Q: Is the check result normal?

YES : Go to Step 7.

NO : Go to Step 6.

STEP 6. Check the wiring harness between fusible link No. 34 and C-309 ETACS-ECU connector terminal No.1.

- Check the power supply lines (battery power supply) for open circuit and short circuit.

Q: Is the check result normal?

YES : If a trouble is solved, it is determined that there is an intermittent malfunction such as poor engaged connector(s) or open circuit (Refer to GROUP 00 – How to Cope with Intermittent Malfunction [P.00-15](#)).

NO : Repair the wiring harness.

STEP 7. Measure the voltage at the C-209 steering wheel sensor connector.

- (1) Disconnect C-209 steering wheel sensor connector and measure the voltage at the wiring harness side of the connector.
- (2) Turn the ignition switch to the ON position.
- (3) Measure the voltage between the terminal No.2 and the body ground.

OK: Approximately battery positive voltage

Q: Is the check result normal?

YES : Go to Step 10.

NO : Go to Step 8.

STEP 8. Check the fuse No.12.

Visually check for open circuit in fuse No.12.

Q: Is the check result normal?

YES : Go to Step 9.

NO : The short circuit may be present in the power supply circuit. Check the wiring harness between the C-209 steering wheel sensor connector terminal No.2 and the C-317 ETACS-ECU connector terminal No.5, and repair if necessary. And then replace the fuse No.12.

STEP 9. Check the wiring harness between C-209 steering wheel sensor connector terminal No.2 and C-317 ETACS-ECU connector terminal No.5.

- Check the power supply lines (battery power supply) for open circuit.

Q: Is the check result normal?

YES : Go to Step 10.

NO : Repair the wiring harness between the C-209 steering wheel sensor connector terminal No.2 and the C-317 ETACS-ECU connector terminal No.5.

STEP 10. Using scan tool MB991958, check the ETACS system data list

Check the input signal of IG1 relay.

- Turn the ignition switch to the ON position.

Item No.	Item name	Normal condition
Item 254	IG voltage	System voltage

OK: Normal condition is displayed.

Q: Is the check result normal?

YES : Replace the steering wheel sensor.

NO : Refer to GROUP 54A - ETACS -Input Signal Procedure 2 "The ignition switch (IG1) signal is not received." [P.54A-704](#).

DATA LIST REFERENCE TABLE

The following items of ECU input data can be read using the scan tool.

1. The system is normal.

Item No.	Check item	Check conditions	Normal conditions
01	FL wheel speed sensor	Perform a test run of the vehicle.	The speedometer display and scan tool display almost agree with each other. <Vehicle stopped: Approximately 0.7 km/h (1.1 mph)>
02	FR wheel speed sensor		
03	RL wheel speed sensor		
04	RR wheel speed sensor		
05	Power supply voltage		System voltage (10 to 18 V ASC operable range)
07	Brake switch (input)	The brake pedal is depressed.	ON
		The brake pedal is released.	OFF
08	Lateral G sensor (+: left turn, -: right turn)	Vehicle stopped (level)	-0.11 to 0.11 G
		Running	-1 to 1 G
09	G sensor (+: deceleration, -: acceleration)	Vehicle stopped (level)	-0.11 to 0.11 G
		Running	-1 to 1 G
10	Master cylinder pressure	The brake pedal is depressed.	Increases by the amount of the brake pedal depression.
		The brake pedal is released.	-3 to 3 bar
11	Steering angle (+: left turn, -: right turn)	Vehicle stopped (Steering wheel in neutral position)	-6 to 6 deg
		Running	Nearly the same as the steering wheel operation angle <-720 to 720 deg (ASC-ECU normal detection value)>
		When removed from vehicle (Steering wheel sensor as a single unit)	Nearly the same as the steering wheel operation angle <-850 to 850 deg (Sensor normal value as a single unit)>
12	Yaw rate sensor (+: left turn, -: right turn)	Vehicle stopped (level)	-3.6 to 3.6 deg/s
		Running	-100 to 100 deg/s
14	Brake switch	The brake pedal is depressed.	ON
		The brake pedal is released.	OFF
15	Emission test mode	Emission test mode: ON	ON
		Emission test mode: OFF	OFF
26	Brake fluid pressure switch	Brake fluid level is lower than the "LOWER" marking.	Low
		Brake fluid level is higher than the "LOWER" marking.	Normal

Item No.	Check item	Check conditions	Normal conditions
28	ASC/TCL off switch	ASC OFF switch not operated (ASC control is available)	ON
		When ASC OFF switch is operated (pressed shortly) (ASC control is prohibited)	OFF
		When ASC OFF switch is operated (pressed and held for 15 seconds or more) (ASC OFF control is prohibited by fail-safe.)	ON
45	SAS OK flag	When the learning is completed	Comp
		When the learning is not completed	Not Comp
		When the steering wheel sensor is faulty	SAS fail SAS fail&Not Comp
65	Engine Speed	When the accelerator pedal is depressed (engine started)	The tachometer display and the scan tool display almost agree with each other.
66	Engine torque		Displays the engine torque.
67	APS sensor		Displays the accelerator pedal opening angle.
68	Allow ESP torque request	Engine torque intervention is permitted	Allow
70	Target gear	The shift lever is operated	Displays the shift lever position.
71	Actual gear		
72	Master cylinder pressure Offset	Master cylinder pressure sensor correction amount at the master cylinder pressure sensor calibration	-8 to 8 bar
73	Lateral G sensor offset	Lateral G sensor correction amount at G and yaw rate sensor calibration	-0.15 to 0.15 G
86	Ignition switch	Ignition switch is "ON" position	ON
87	Ignition switch (input)	Ignition switch is "ON" position	ON
		Ignition switch is "START" position	START
88	Vehicle speed	Perform a test run of the vehicle.	The speedometer display and scan tool display almost agree with each other.
91	Brake pressure sensor	The brake pedal is depressed.	Pressed
		The brake pedal is released.	Not pressed
96	G sensor offset	Longitudinal G sensor correction amount at G and yaw rate sensor calibration	-0.3 to 0.3 G
97	Yaw rate sensor offset	Yaw rate sensor correction amount at G and yaw rate sensor calibration	-6.0 to 6.0 deg/s

Item No.	Check item	Check conditions	Normal conditions
105	Power supply voltage (input)		System voltage (10 to 18 V ASC operable range)
120	Parking brake switch (input)	When the parking brake lever is pulled up.	ON
		When the parking brake lever is released.	OFF
128	ASC/TCL off switch	When the ASC OFF switch is pressed.	ON
		When the ASC OFF switch is not pressed.	OFF
129	FL wheel cylinder pressure	The brake pedal is depressed.	Increases by the amount of the brake pedal depression.
		The brake pedal is released.	-3 to 3 bar
130	FR wheel cylinder pressure	The brake pedal is depressed.	Increases by the amount of the brake pedal depression.
		The brake pedal is released.	-3 to 3 bar
131	RL wheel cylinder pressure	The brake pedal is depressed.	Increases by the amount of the brake pedal depression.
		The brake pedal is released.	-3 to 3 bar
132	RR wheel cylinder pressure	The brake pedal is depressed.	Increases by the amount of the brake pedal depression.
		The brake pedal is released.	-3 to 3 bar
133	FL wheel cylinder pres. offset	Wheel cylinder fluid pressure sensor correction amount	-8 to 8 bar
134	FR wheel cylinder pres. offset		
135	RL wheel cylinder pres. offset		
136	RR wheel cylinder pres. offset		

2. System shutdown by ECU

While ASC-ECU is disabled by the diagnostic function, the scan tool displayed data is different from the actual measurement.

ACTUATOR TEST REFERENCE TABLE

Using scan tool, the following actuators can be forcibly operated:

NOTE:

- ABS, TCL, and stability control are operated by ASC-ECU.
- When ASC-ECU is disabled due to the fail-safe function, the actuator test cannot be performed.
- The actuator test can be performed only when the vehicle is stationary.

M1355001600172

- While the actuator test is performed, the ABS warning light flashes at a rate of 2 Hz.
- After the actuator test has been performed, the brake warning light, ABS warning light, ASC ON indicator light, and ASC OFF indicator light illuminate until the ignition switch is turned to ON again or the communication between scan tool and ASC-ECU is terminated.

Actuator test specifications

Item No.	Check item	Driven component
01	FL wheel ABS drive	Solenoid valve for the corresponding channel of the hydraulic unit and pump motor (simplified inspection mode)
02	FR wheel ABS drive	
03	RL wheel ABS drive	
04	RR wheel ABS drive	
05	FL wheel TCL drive	
06	FR wheel TCL drive	
07	RL wheel TCL drive	
08	RR wheel TCL drive	
09	Engine TCL drive	Outputs the engine torque control signal (engine torque = 0 N·m) to the engine ECU for three seconds.

Operation pattern of items 01 to 08

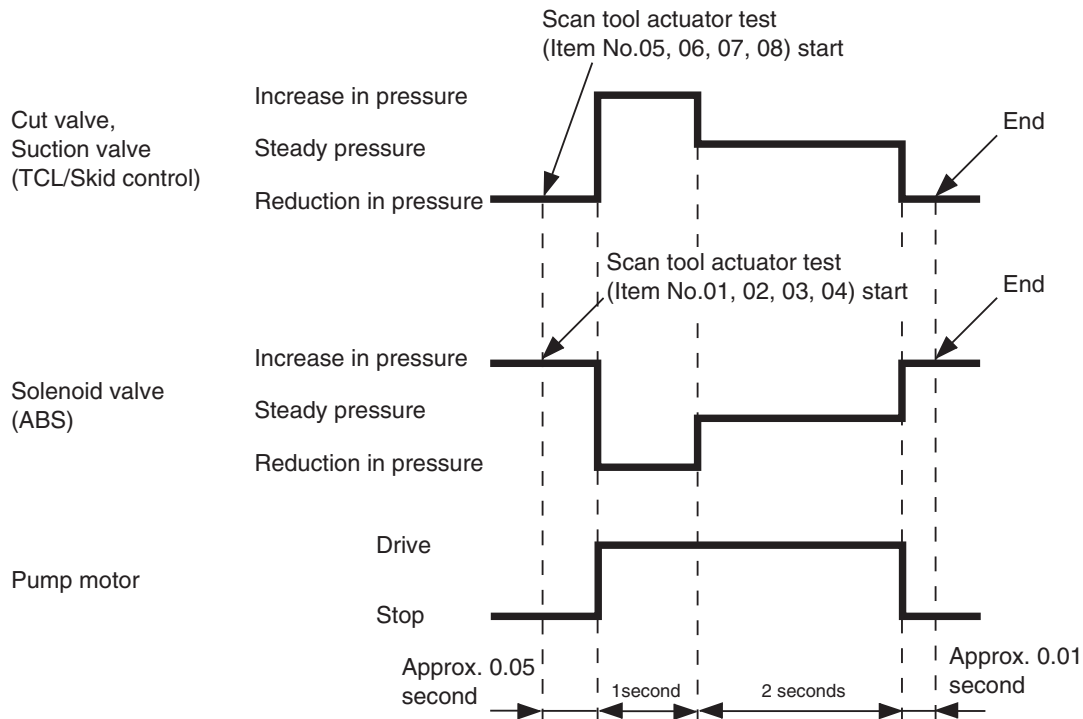

AC400776AB

CHECK AT ECU TERMINALS

M1355001700191

TERMINAL VOLTAGE CHECK

Required Special Tool:

MB991997: ASC Check Harness

1. Operate the lock lever as shown in the figure to disconnect the ASC-ECU wiring harness connector.

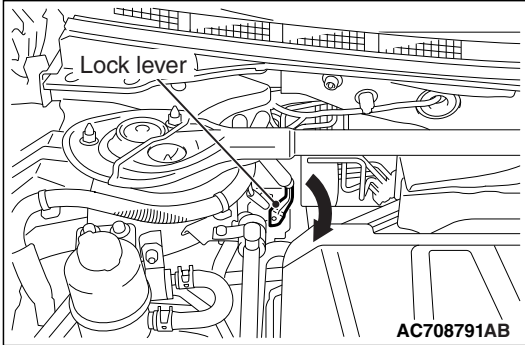

2. Connect special tool ASC Check Harness (MB991997) to measure the voltage between each check connector terminal and the ground terminal (No. 16 or 47).

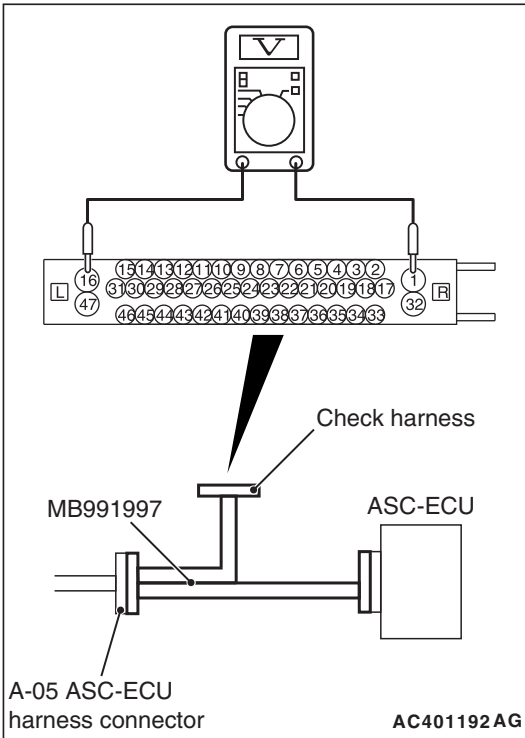

Terminal No.	Check item	Check conditions	Normal conditions
1	Motor power supply	Ignition switch: ON (OFF)	Battery positive voltage
2	ASC-ECU power supply	Ignition switch: ON (OFF)	Battery positive voltage
22	G and yaw rate sensor power supply	Ignition switch: ON	Battery positive voltage
32	Solenoid valve power supply	Ignition switch: ON (OFF)	Battery positive voltage
34	Wheel speed sensor (FR) power supply	Ignition switch: ON	Battery positive voltage
36	Wheel speed sensor (RL) power supply	Ignition switch: ON	Battery positive voltage
43	Wheel speed sensor (RR) power supply	Ignition switch: ON	Battery positive voltage
45	Wheel speed sensor (FL) power supply	Ignition switch: ON	Battery positive voltage

**RESISTANCE AND CONTINUITY BETWEEN
HARNESS-SIDE CONNECTOR TERMINALS**

Required Special Tool:

MB991997: ASC Check Harness

1. Operate the lock lever as shown in the figure to disconnect the ASC-ECU wiring harness connector.

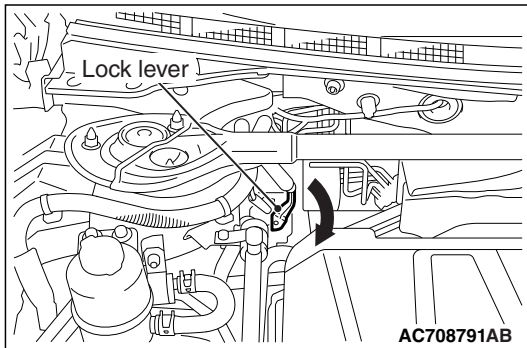

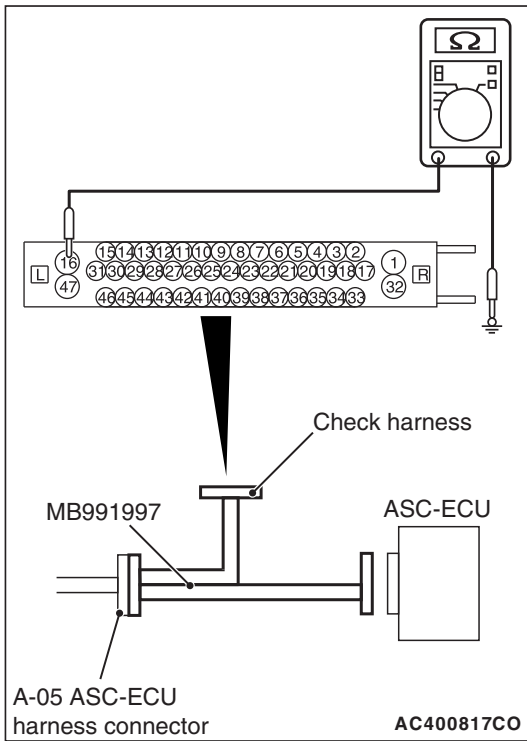

2. When performing the continuity check, turn the ignition switch to LOCK (OFF) position, connect special tool ASC Check Harness (MB991997) as shown in the figure, and disconnect the ASC-ECU connector.
3. Check for continuity between terminals shown in the chart below.
4. Terminal layout is shown in the figure.

Terminal No.	Signal	Normal conditions
16 -body ground	Ground	Continuity exists (2 Ω or less)
47 -body ground	Ground	Continuity exists (2 Ω or less)

SPECIAL TOOLS

M1355005800101

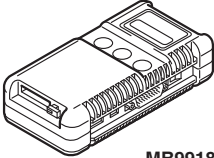
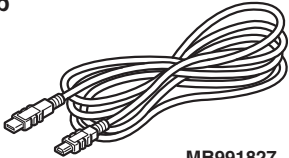
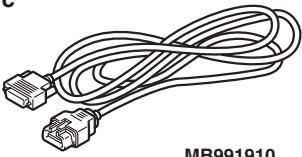
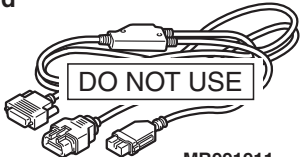
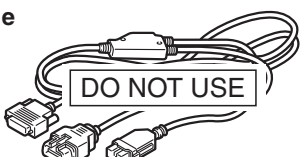
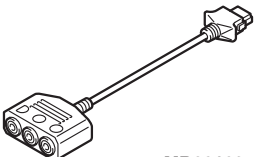
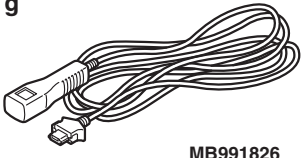
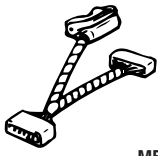
Tool	Tool number and name	Supersession	Application
<p>a</p>  <p>MB991824</p> <p>b</p>  <p>MB991827</p> <p>c</p>  <p>MB991910</p> <p>d</p>  <p>MB991911</p> <p>e</p>  <p>MB991914</p> <p>f</p>  <p>MB991825</p> <p>g</p>  <p>MB991826 MB991958</p>	<p>MB991958</p> <p>a. MB991824</p> <p>b. MB991827</p> <p>c. MB991910</p> <p>d. MB991911</p> <p>e. MB991914</p> <p>f. MB991825</p> <p>g. MB991826</p> <p>M.U.T.-III sub assembly</p> <p>a. Vehicle communication interface (V.C.I.)</p> <p>b. M.U.T.-III USB cable</p> <p>c. M.U.T.-III main harness A (Vehicles with CAN communication system)</p> <p>d. M.U.T.-III main harness B (Vehicles without CAN communication system)</p> <p>e. M.U.T.-III main harness C (for Daimler Chrysler models only)</p> <p>f. M.U.T.-III measurement adapter</p> <p>g. M.U.T.-III trigger harness</p>	<p>MB991824-KIT</p> <p><i>NOTE: G: MB991826 M.U.T.-III Trigger Harness is not necessary when pushing V.C.I. ENTER key.</i></p>	<p>⚠ CAUTION</p> <p>M.U.T.-III main harness A (MB991910) should be used. M.U.T.-III main harness B and C should not be used for this vehicle.</p> <p>ASC check (Diagnostic trouble code display, service data display and calibration by scan tool)</p>
 <p>MB991997</p>	<p>MB991997</p>	<p>ASC check harness</p>	<p>Voltage inspection at ASC-ECU terminals</p>

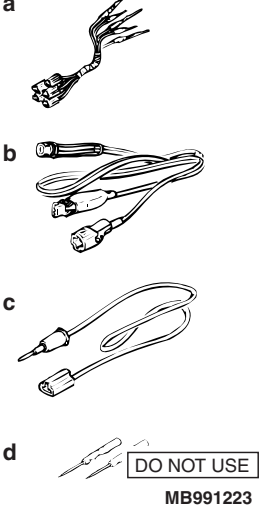
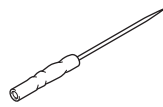
Tool	Tool number and name	Supersession	Application
	<p>MB991223</p> <p>a. MB991219 b. MB991220 c. MB991221 d. MB991222</p> <p>Harness set</p> <p>a. Test harness b. LED harness c. LED harness adaptor d. Probe</p>	<p>General service tools</p>	<p>Continuity check and voltage measurement at harness wire or connector for loose, corroded or damaged terminals, or terminals pushed back in the connector.</p> <p>a. Connector pin contact pressure inspection b. Power circuit inspection c. Power circuit inspection d. Commercial tester connection</p>
 <p>MB992006</p>	<p>MB992006</p> <p>Extra fine probe</p>	<p>–</p>	<p>Continuity check and voltage measurement at harness wire or connector for loose, corroded or damaged terminals, or terminals pushed back in the connector.</p>

ON-VEHICLE SERVICE

HYDRAULIC UNIT CHECK

M1355006100138

Required Special Tools:

- MB991958: M.U.T.-III Sub Assembly
 - MB991824: Vehicle Communication Interface (V.C.I.)
 - MB991827: M.U.T.-III USB Cable
 - MB991910: M.U.T.-III Main Harness A (Vehicles with CAN communication system)

1. Raise the vehicle using a jack and support the specified points with a rigid rack.

⚠ CAUTION

Before connecting or disconnecting scan tool, always turn the ignition switch to the LOCK (OFF) position.

2. Before setting scan tool, turn the ignition key to the LOCK (OFF) position.
3. With the M/T vehicles, check that the shift lever is in the neutral position. With the TC-SST vehicle, check that the selector lever is in the "N" position. Then, start the engine of the vehicle.

- When carrying out the actuator tests No. 01 to 04, perform the actuator tests using scan tool while depressing the brake pedal. When carrying out the actuator tests No.05 to 08, perform the actuator tests using scan tool without depressing the brake pedal. When carrying out the actuator tests, rotate the wheel by hands to confirm that the braking force changes.

NOTE:

- While performing the actuator test, the ABS warning light flashes at a rate of 2 Hz.
- When ASC-ECU is disabled due to the fail-safe function, the M.U.T.-III actuator test cannot be performed.
- After the actuator test has been performed, the ABS warning light, brake warning light, ASC warning display, and ASC OFF indicator light illuminate until the ignition switch is turned to ON again or the communication between scan tool and ASC-ECU is terminated.

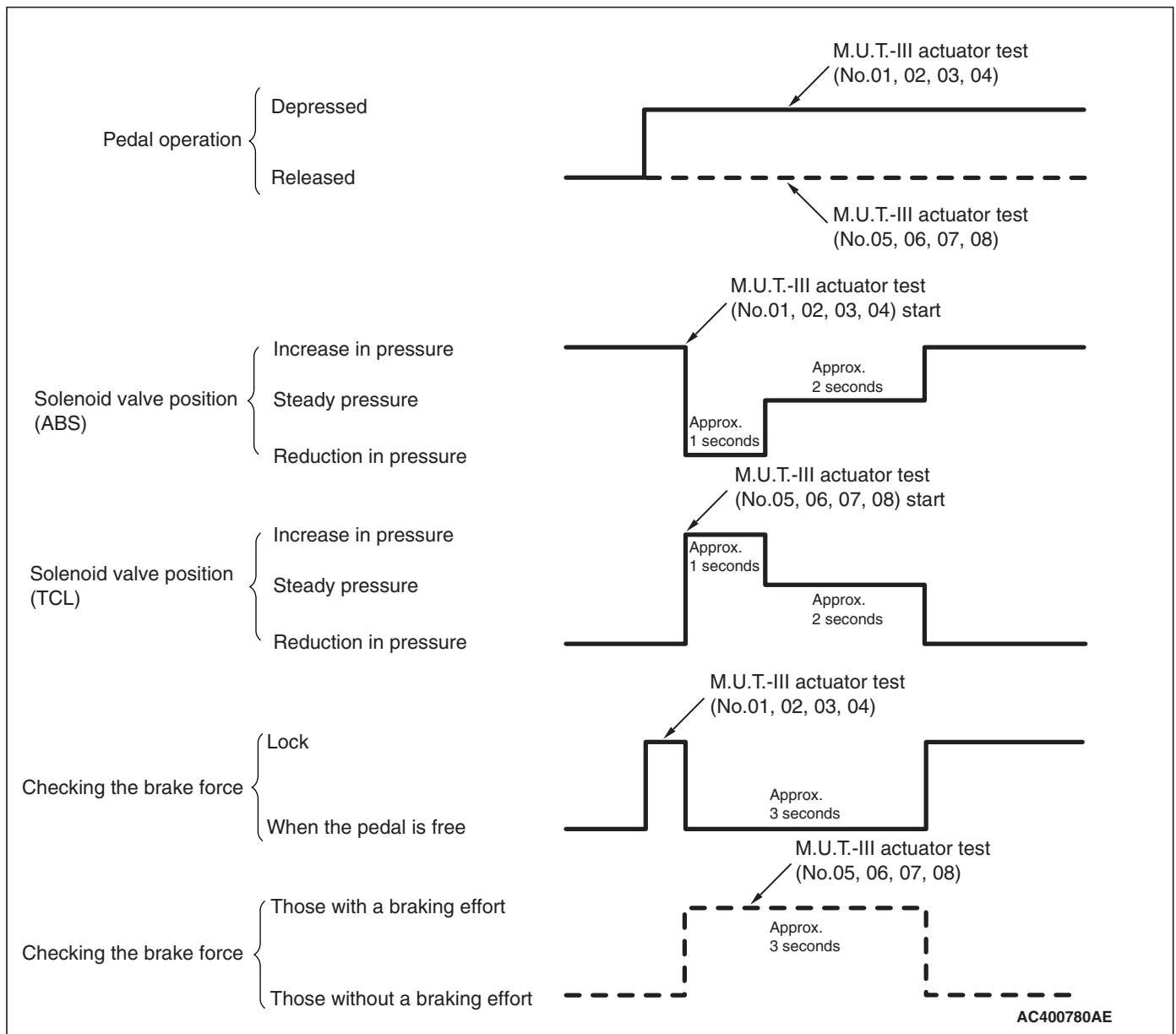

5. This is indicated as shown in the above.
6. When any malfunction has been found, take a necessary action according to the "Judgment Table."

Judgment Table

Display on scan tool	Operation	Inspection result	Judgment	Probable cause	Remedy
01 FL wheel ABS drive 02 FR wheel ABS drive 03 RL wheel ABS drive 04 RR wheel ABS drive	<ul style="list-style-type: none"> • Depress the brake pedal to lock the vehicle. • Select the vehicle to be inspected using scan tool, perform the actuator test. • Rotate the selected wheel by hands to confirm the braking force. 	Braking force decreases for 3 seconds from the lock status.	Normal	–	–
		The wheel does not lock even if the brake pedal is depressed.	Error	Clogged brake line other than hydraulic unit	Check and clean the brake line.
		Braking force does not decrease.	Error	Clogged hydraulic circuit in the hydraulic unit	Replace the hydraulic unit assembly.
				Faulty routing of hydraulic unit brake tube	Route the brake tube correctly.
05 FL wheel TCL drive 06 FR wheel TCL drive 07 RL wheel TCL drive 08 RR wheel TCL drive	<ul style="list-style-type: none"> • Select the vehicle to be inspected using scan tool, perform the actuator test. • Rotate the selected wheel by hands to confirm the braking force. 	Lock condition occurs for 3 seconds from the status without braking force.	Normal	–	–
		The wheel does not lock.	Error	<ul style="list-style-type: none"> • Faulty routing of hydraulic unit brake tube • Clogged brake line other than hydraulic unit 	Check and clean the brake line.
				Clogged hydraulic circuit in the hydraulic unit	Replace the hydraulic unit assembly.

7. After the inspection, turn the ignition switch to the LOCK (OFF) position, and then disconnect scan tool.

IN THE EVENT OF A DISCHARGED BATTERY

M1355006200146

WARNING

If the ASC is not operating, the vehicle will be unstable during braking. Do not drive the vehicle with the ASC-ECU connector disconnected or with the ASC not operating.

If the engine is started using a booster cable when the battery is completely flat, and the vehicle is then driven without waiting for the battery to be recharged, the engine may misfire and it may not be possible to drive the vehicle. This is because the ASC consumes a large amount of current when carrying out its initial checks. If this happens, recharge the battery fully.

G AND YAW RATE SENSOR CALIBRATION

M1355009300142

CAUTION

Before performing calibration, check that the G and yaw rate sensor-related diagnostic trouble code is not set.

CAUTION

After the next operation has been completed, carry out the calibration to make ASC-ECU learn the neutral point of the G and yaw rate sensor.

- G and yaw rate sensor replacement
- ASC-ECU replacement

<Vehicles without TC-SST>

1. Park the vehicle on a level surface.
2. Turn the ignition switch to the ON position.
3. Turn the ignition key to the LOCK (OFF) position.

CAUTION

Before connecting or disconnecting scan tool, always turn the ignition switch to the LOCK (OFF) position.

4. Check that the ignition key is in the LOCK (OFF) position, and then set scan tool.
5. Turn the ignition switch to the ON position.
6. On the Menu, select "System selection."
7. On the "System selection," select "ABS/ASC/ASTC/WSS" in the "System table," and then click the "OK" button.
8. In the "ABS/ASC/ASTC/WSS" field, select "Special function".
9. In the "Special function," select "Learn sensor neutral position."
10. Among the selected items, select "Learn G-sensor neutral position" and then press the "OK" button.
11. "Learn G-sensor neutral position: Are you sure to execute the selected item? Note: Check the execution conditions." is displayed. Then, press the "OK" button.
12. "Execute command: Executed" is displayed. Then, press the "OK" button.

13. Among the selected items, select "Learn lateral G-sensor neutral position" and then press the "OK" button.
14. "Learn lateral G-sensor neutral position: Are you sure to execute the selected item? Note: Check the execution conditions." is displayed. Then, press the "OK" button.
15. "Execute command: Executed" is displayed. Then, press the "OK" button.
16. The neutral point is learned.
17. Turn the ignition key to the LOCK (OFF) position, and remove scan tool from the vehicle.

<Vehicles with TC-SST (When the G and yaw rate sensor is replaced)>

1. Perform Step 1-15 of G and yaw rate sensor calibration vehicle without TC-SST.
2. On the Menu, select "System selection."
3. On the "System selection," select "ACD/AYC" in the "System table," and then click the "OK" button.
4. In the "ACD/AYC" field, select "Special function".
5. In the "Special function," select "Learn sensor neutral position."
6. Among the selected items, select "Learn lateral G-sensor neutral position" and then press the "OK" button.
7. "Learn lateral G-sensor neutral position: Are you sure to execute the selected item? Note: Check the execution conditions." is displayed. Then, press the "OK" button.
8. "Execute command: Executed" is displayed. Then, press the "OK" button.
9. Among the selected items, select "Learn G-sensor neutral position" and then press the "OK" button.
10. "Learn G-sensor neutral position: Are you sure to execute the selected item? Note: Check the execution conditions." is displayed. Then, press the "OK" button.
11. "Execute command: Executed" is displayed. Then, press the "OK" button.
12. The neutral point is learned.
13. Turn the ignition key to the LOCK (OFF) position, and remove scan tool from the vehicle.

STEERING WHEEL SENSOR CALIBRATION

M1355009200156

<Vehicles without TC-SST>

CAUTION

After the next operation has been completed, carry out the following two operations:

- Alignment adjustment <Front>
 - Steering wheel sensor (column switch assembly) replacement, removal, installation
 - ASC-ECU replacement
1. Update the neutral position stored in the steering wheel sensor.
 2. Reset the calibrated value of the steering angle stored in ASC-ECU.

CAUTION

- Before performing the calibration, check if the steering wheel sensor-related diagnostic trouble code is set in ASC-ECU.
 - When the diagnostic trouble code other than C121A is set, carry out the inspection according to each troubleshooting procedure.
1. Park the vehicle on a level surface with tires and steering wheel positioned in a straight ahead direction.
 2. Turn the ignition switch to the ON position.
 3. Turn the ignition key to the LOCK (OFF) position.

CAUTION

Before connecting or disconnecting scan tool, always turn the ignition switch to the LOCK (OFF) position.

4. Check that the ignition key is in the LOCK (OFF) position, and then set scan tool.
5. Turn the ignition switch to the ON position.
6. On the Menu, select "System selection."
7. In "System table" of "System selection," select "Steering angle sensor," and then press the "OK" button.
8. In "Steering angle sensor," select "Special function."
9. In "Special function," select "Learn neutral position of steering angle sensor."

NOTE: When the neutral position of steering angle sensor has been learned, "Neutral position learned already: in order to relearn the neutral position, press the OK button to initialize the steering angle sensor neutral position." is displayed. If it is okay, press the "OK" button.

10. In "Learn neutral position of steering angle sensor," "Initialize neutral position of steering angle sensor" is selected, thus press the "OK" button.

NOTE: When the neutral position of steering angle sensor has been learned, "Initialize neutral position of steering angle sensor: Do you want to execute? Note: The diagnostic trouble code will be erased." is displayed. Then, press the "OK" button.

11. "Initialize neutral position of steering angle sensor: Completed" is displayed. Then, press the "OK" button.
12. Press the "OK" button.
13. "Learn neutral position of steering angle sensor: Do you want to execute? Note: Execute after the tires and steering wheel are aligned in a straight ahead direction." is displayed. Then, press the "OK" button.
14. "Learn neutral position of steering angle sensor: Completed" is displayed. Then, press the "OK" button.
15. After turning the ignition switch to LOCK (OFF) position, turn it to the ON position again.
16. On the Menu, select "System selection."
17. On the "System selection," select "ABS/ASC/ASTC/WSS" in the "System table," and then click the "OK" button.
18. In the "ABS/ASC/ASTC/WSS" field, select "Special function".
19. In the "Special function," select "Learn sensor neutral position."
20. In "Learn sensor neutral position," select "Learn neutral position of steering angle sensor," and then press the "OK" button.
21. "Learn neutral position of steering angle sensor: Are you sure to execute the selected item? Note: Check the execution conditions." is displayed. Then, press the "OK" button.
22. "Execute command: Executed" is displayed. Then, press the "OK" button.
23. In the "ABS/ASC/ASTC/WSS" field, select "Self diagnosis." If diagnostic trouble code of "C2205 SAS internal error (past failure)" is set, erase it.
24. The neutral point is learned.
25. Turn the ignition key to the LOCK (OFF) position, and remove scan tool from the vehicle.

<Vehicles with TC-SST>

CAUTION

After the next operation has been completed, carry out the following two operations:

- Alignment adjustment <Front>
 - Steering wheel sensor (column switch assembly) replacement, removal, installation
 - ASC-ECU replacement
1. Update the neutral position stored in the steering wheel sensor.
 2. Reset the calibrated value of the steering angle stored in ASC-ECU.
 3. Reset the calibrated value of the steering angle stored in AWC-ECU. <Only when replace of the steering wheel sensor, removal, or installation is performed.>

CAUTION

- Before performing the calibration, check if the steering wheel sensor-related diagnostic trouble code is set in ASC-ECU.
- When the diagnostic trouble code other than C121A is set, carry out the inspection according to each troubleshooting procedure.

<When ASC-ECU is replaced>

1. Park the vehicle on a level surface with tires and steering wheel positioned in a straight ahead direction.
2. Turn the ignition switch to the ON position.
3. Turn the ignition key to the LOCK (OFF) position.

CAUTION

Before connecting or disconnecting scan tool, always turn the ignition switch to the LOCK (OFF) position.

4. Check that the ignition key is in the LOCK (OFF) position, and then set scan tool.
5. Turn the ignition switch to the ON position.
6. On the Menu, select "System selection."
7. In "System table" of "System selection," select "Steering angle sensor," and then press the "OK" button.
8. In "Steering angle sensor," select "Special function."
9. In "Special function," select "Learn neutral position of steering angle sensor."

NOTE: When the neutral position of steering angle sensor has been learned, "Neutral position learned already: in order to relearn the neutral position, press the OK button to initialize the steering angle sensor neutral position." is displayed. If it is okay, press the "OK" button.

10. In "Learn neutral position of steering angle sensor," "Initialize neutral position of steering angle sensor" is selected, thus press the "OK" button.

NOTE: When the neutral position of steering angle sensor has been learned, "Initialize neutral position of steering angle sensor: Do you want to execute? Note: The diagnostic trouble code will be erased." is displayed. Then, press the "OK" button.

11. "Initialize neutral position of steering angle sensor: Completed" is displayed. Then, press the "OK" button.
12. Press the "OK" button.
13. "Learn neutral position of steering angle sensor: Do you want to execute? Note: Execute after the tires and steering wheel are aligned in a straight ahead direction." is displayed. Then, press the "OK" button.
14. "Learn neutral position of steering angle sensor: Completed" is displayed. Then, press the "OK" button.
15. After turning the ignition switch to LOCK (OFF) position, turn it to the ON position again.
16. On the Menu, select "System selection."
17. On the "System selection," select "ABS/ASC/ASTC/WSS" in the "System table," and then click the "OK" button.
18. In the "ABS/ASC/ASTC/WSS" field, select "Special function".
19. In the "Special function," select "Learn sensor neutral position."
20. In "Learn sensor neutral position," select "Learn neutral position of steering angle sensor," and then press the "OK" button.
21. "Learn neutral position of steering angle sensor: Are you sure to execute the selected item? Note: Check the execution conditions." is displayed. Then, press the "OK" button.
22. "Execute command: Executed" is displayed. Then, press the "OK" button.
23. In the "ABS/ASC/ASTC/WSS" field, select "Self diagnosis." If diagnostic trouble code of "C2205 SAS internal error (past failure)" is set, erase it.
24. The neutral point is learned.
25. Turn the ignition key to the LOCK (OFF) position, and remove scan tool from the vehicle.

<When steering wheel sensor is replaced>

1. When the ASC-ECU has been changed, carry out the steering wheel sensor calibration procedures from Step 1–23.
2. On the Menu, select "System selection."
3. In "System table" of "System selection," select "ACD/AYC" and then press the "OK" button.
4. In "ACD/AYC" select "Special function."
5. In "Special function," select "Learn neutral position of steering angle sensor."

NOTE: When the neutral position of steering angle sensor has been learned, "Neutral position learned already: in order to relearn the neutral position, press the OK button to initialize the steering angle sensor neutral position." is displayed. If it is okay, press the "OK" button.

6. In "Learn neutral position of steering angle sensor," "Initialize neutral position of steering angle sensor" is selected, thus press the "OK" button.

NOTE: When the neutral position of steering angle sensor has been learned, "Initialize neutral position of steering angle sensor: Do you want to execute? Note: The diagnostic trouble code will be erased." is displayed. Then, press the "OK" button.

7. "Initialize neutral position of steering angle sensor: Completed" is displayed. Then, press the "OK" button.
8. Press the "OK" button.
9. "Learn neutral position of steering angle sensor: Do you want to execute? Note: Execute after the tires and steering wheel are aligned in a straight ahead direction." is displayed. Then, press the "OK" button.
10. "Learn neutral position of steering angle sensor: Completed" is displayed. Then, press the "OK" button.
11. After turning the ignition switch to LOCK (OFF) position, turn it to the ON position again.
12. On the Menu, select "System selection."
13. On the "System selection," select "ACD/AYC" in the "System table," and then click the "OK" button.
14. In the "ACD/AYC" field, select "Special function".
15. In the "Special function," select "Learn sensor neutral position."
16. In "Learn sensor neutral position," select "Learn neutral position of steering angle sensor," and then press the "OK" button.
17. "Learn neutral position of steering angle sensor: Are you sure to execute the selected item? Note: Check the execution conditions." is displayed. Then, press the "OK" button.
18. "Execute command: Executed" is displayed. Then, press the "OK" button.
19. In the "ACD/AYC" field, select "Self diagnosis." If diagnostic trouble code of "U1428 G and yaw rate sensor data error (past failure)" is set, erase it.
20. The neutral point is learned.
21. Turn the ignition key to the LOCK (OFF) position, and remove scan tool from the vehicle.

**MASTER CYLINDER BRAKE FLUID PRESSURE
SENSOR CALIBRATION**

M1355024500013

⚠ CAUTION

- Before performing the calibration, check that the wheel cylinder brake fluid pressure sensor-related diagnostic trouble code is not set.
- Always perform the calibration with the brake pedal released (stoplight switch is turned off).
- After the operation below is completed, perform the calibration to make ASC-ECU to learn the neutral point of the wheel cylinder brake fluid pressure sensor.
 1. Troubleshooting for diagnostic trouble code No. C123A
 2. ASC-ECU replacement
 1. Park the vehicle on a level surface.
 2. Turn the ignition key to the ON position.
 3. Turn the ignition key to the LOCK (OFF) position.

⚠ CAUTION

Before connecting or disconnecting scan tool MB991958, always turn the ignition switch to the LOCK (OFF) position.

4. Check that the ignition key is in the LOCK (OFF) position, and then set scan tool MB991958.
5. Turn the ignition switch to the ON position.
6. On the Menu, select "System selection."
7. On the "System selection," select "ABS/ASC/ASTC/WSS" in the system list, and then click the "OK" button.
8. Select "Special function" in the "ABS/ASC/ASTC/WSS" field.
9. In the "Special function," select "Learn sensor neutral position."
10. Among the selected items, select "Learn M/C pressure sensor neutral position," and then press the "OK" button.
11. When a message "Learn M/C pressure sensor neutral position: Are you sure to execute the selected item? Caution: Check the execution conditions" is displayed, press the "OK" button.
12. When a message "Command execution: Command has been executed" is displayed, press the "OK" button.
13. The neutral point is learned.
14. Turn the ignition key to the LOCK (OFF) position, and then remove the scan tool from the vehicle.

Calibration of cut valve and inlet valve

M1355024700017

CAUTION

- Before the calibration work of the cut valve and inlet valve, check that no diagnostic trouble code is set relating to the cut valve, inlet valve, motor system, power supply system, or ECU system.
- Always perform the calibration of cut valve and inlet valve with the brake pedal released (stoplight switch is turned off).
- If any diagnostic trouble code other than No. C2002 is also set, always perform the diagnosis of the diagnostic trouble code other than No. C2002 first.
- After the replacement of ASC-ECU, the calibration of cut valve and inlet valve must be performed with the new ASC-ECU.
- When the cut valve calibration is performed, the calibration of master cylinder fluid pressure sensor is also executed at the same time.
- When the cut valve calibration is not completed, the inlet valve calibration cannot be performed.
- After the completion of following works, always perform the calibration of cut valve and inlet valve.
 1. Diagnosis for the diagnostic trouble code No. C2002 is performed.
 2. ASC-ECU replacement
 1. Park the vehicle on a level surface.
 2. Turn the ignition key to the ON position.
 3. Turn the ignition key to the LOCK (OFF) position.

CAUTION

Before connecting or disconnecting scan tool, always turn the ignition switch to the LOCK (OFF) position.

4. Check that the ignition key is in the LOCK (OFF) position, and then set scan tool.
5. Turn the ignition switch to the ON position.
6. On the Menu, select "System selection."
7. On the "System selection," select "ABS/ASC/ASTC/WSS" in the system list, and then click the "OK" button.
8. Select "Special function" in the "ABS/ASC/ASTC/WSS" field.
9. In the "Special function," select "Learn valve fluid pressure."
10. Among the selected items, select "Cut valve fluid pressure," and then press the "OK" button.
11. When a message "Cut valve fluid pressure: Are you sure to execute the selected item? Caution: Check the execution conditions" is displayed, press the "OK" button.
12. When a message "Command execution: Command has been executed" is displayed, press the "OK" button.
13. Check that the message changes from "Under execution" to "Complete."

NOTE: The cut valve fluid pressure learning requires approximately 20 seconds.

14. Among the selected items, select "Inlet valve fluid pressure," and then press the "OK" button.
15. When a message "Inlet valve fluid pressure: Are you sure to execute the selected item? Caution: Check the execution conditions" is displayed, press the "OK" button.
16. When a message "Command execution: Command has been executed" is displayed, press the "OK" button.
17. Check that the message changes from "Under execution" to "Complete."

NOTE: The inlet valve fluid pressure learning requires approximately 20 seconds.

18. The valve fluid pressure learning is complete.
19. Turn the ignition key to the LOCK (OFF) position, and then remove the scan tool from the vehicle.

ASC OFF SWITCH

REMOVAL AND INSTALLATION

M1355020100109

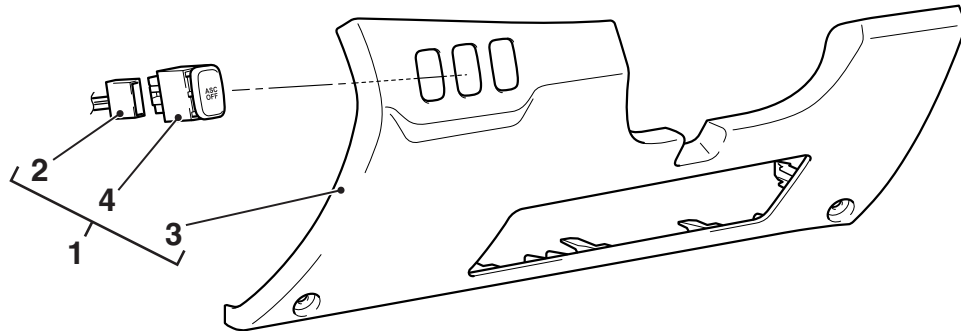

AC708758AB

Removal steps

1. Instrument panel lower assembly
(Refer to GROUP 52A –
Instrumental Lower Panel [P.52A-9.](#))
2. ASC OFF switch connector

Removal steps (Continued)

3. Instrument panel lower
4. ASC OFF switch

INSPECTION

M1355020200106

ASC OFF SWITCH CONTINUITY CHECK

1. As shown in the figure, connect the circuit tester to the ASC OFF switch as a single unit.
2. Check the continuity of when the ASC OFF switch is pressed and released.

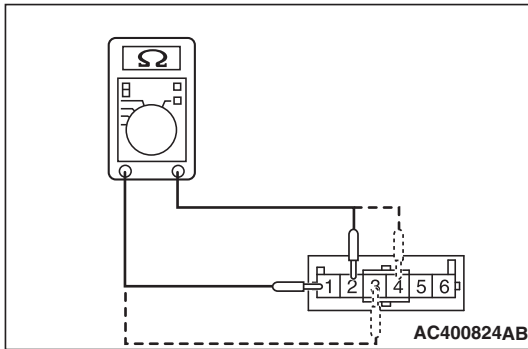

Item	ASC OFF switch is released (not operated)	ASC OFF switch is pressed
Continuity between terminal No. 1 and No. 2	No continuity	Continuity exists (2Ω or less)
Continuity between terminal No. 3 and No. 4	Continuity exists	Continuity exists

HYDRAULIC UNIT

REMOVAL AND INSTALLATION

M1355005600196

NOTE: ASC-ECU is located in the hydraulic unit.

CAUTION

When the hydraulic unit (integrated with ASC-ECU) is replaced, after turning the ignition switch ON and OFF (vehicle information from ETACS-ECU is registered), always perform the calibration of steering wheel sensor, G and yaw rate sensor, brake fluid pressure sensor, cut valve, and inlet valve. (Refer to P.35C-287, P.35C-289, P.35C-294, and P.35C-295.)

<p>Pre-removal operation</p> <ul style="list-style-type: none"> • Strut tower bar removal (Refer to GROUP 42A –Strut Tower Bar P.42A-14). • Brake fluid draining. 	<p>Post-installation operation</p> <ul style="list-style-type: none"> • Brake fluid refilling and air bleeding (Refer to GROUP 35A –On-vehicle Service, Brake Fluid Level Inspection and Bleeding P.35A-16). • Strut tower bar installation (Refer to GROUP 42A –Strut Tower Bar P.42A-14). • Hydraulic unit check (Refer to P.35C-284).
--	--

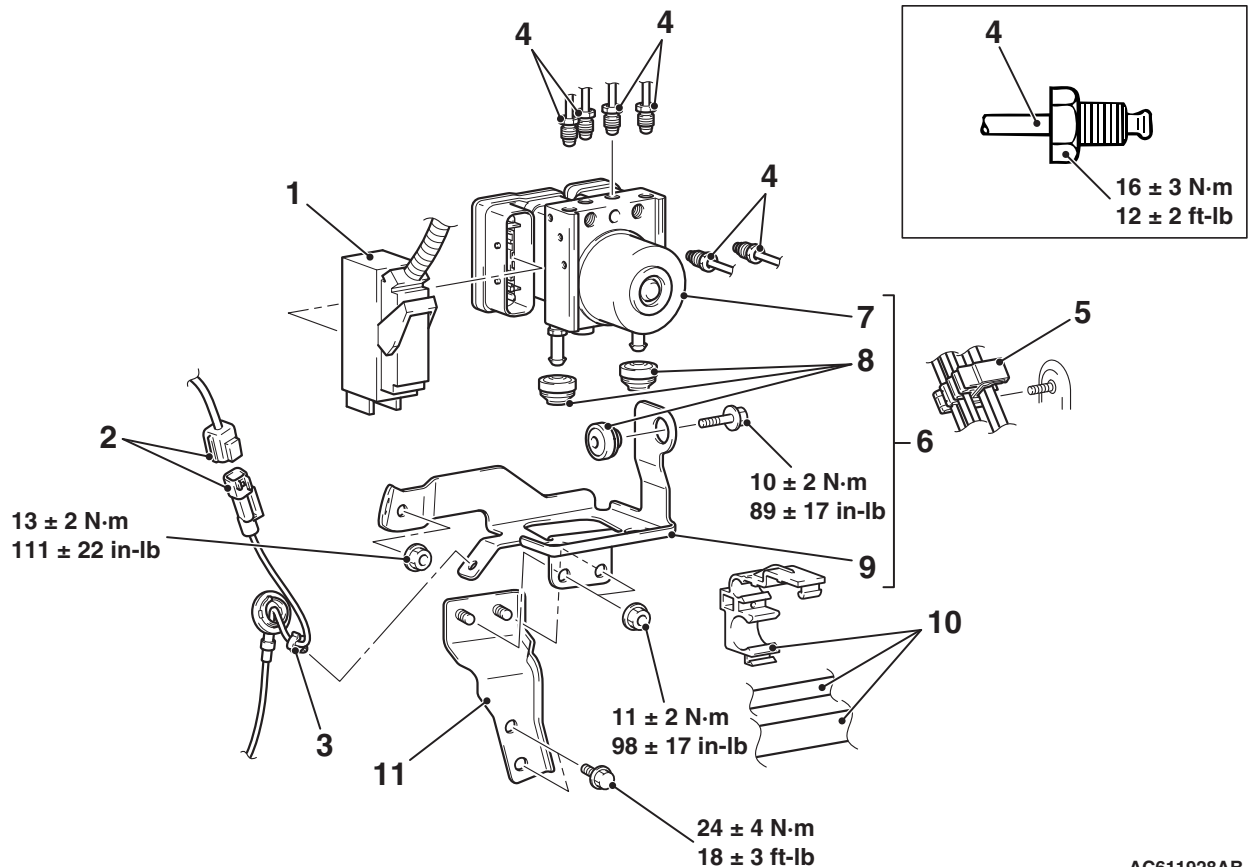

AC611928AB

- <<A>>
- Removal steps**
1. ASC-ECU harness connector
 2. Wheel speed sensor harness connector connection
 3. Wheel speed sensor harness clip connection
- >>A<<
4. Brake tube connection
 5. Brake tube clip and body connection

<>

- Removal steps (Continued)**
6. Hydraulic unit (ASC-ECU) and hydraulic unit bracket
 7. Hydraulic unit (ASC-ECU)
 8. Hydraulic unit bracket insulator
 9. Hydraulic unit bracket B
 10. Suction pipe, liquid pipe and clip connection
 11. Hydraulic unit bracket A

REMOVAL SERVICE POINTS

<<A>> ASC-ECU WIRING HARNESS CONNECTOR DISCONNECTION

Operate the lock lever as shown in the figure to disconnect the ASC-ECU wiring harness connector.

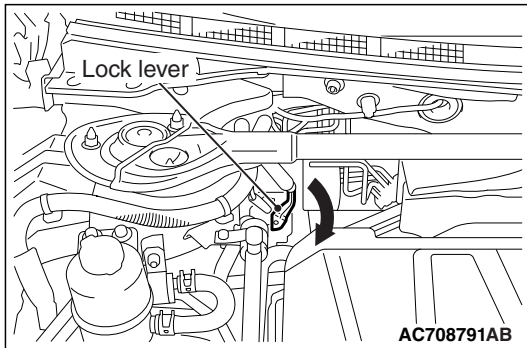

<> HYDRAULIC UNIT (ASC-ECU) REMOVAL

⚠ CAUTION

- Be careful when removing the hydraulic unit because it is heavy.
- Never loosen the nuts and the bolts because the hydraulic unit cannot be disassembled.
- Do not drop or shock the hydraulic unit.
- Do not turn the hydraulic unit upside down or lay down the unit because the inner air becomes difficult to be bled.

INSTALLATION SERVICE POINT

>>A<< BRAKE TUBE CONNECTION

Install the brake pipe to the hydraulic unit as shown in the figure.

1. From master cylinder (primary)
2. To front brake (RH)
3. To front brake (LH)
4. From master cylinder (secondary)
5. To rear brake (RH)
6. To rear brake (LH)

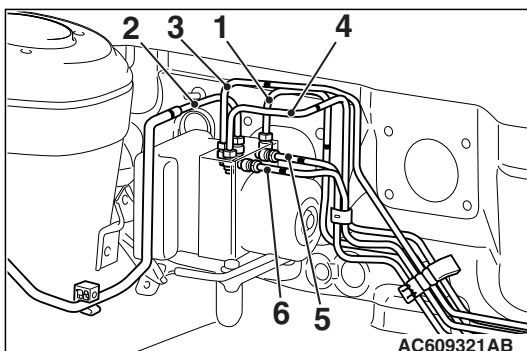

WHEEL SPEED SENSOR

REMOVAL AND INSTALLATION

M1355005300162

CAUTION

The vehicle speed detection encoder collects any metallic particle easily, because it is magnetized. Make sure that the encoder should not collect any metallic particle. Check that there is not any trouble prior to reassembling it.

<Front>

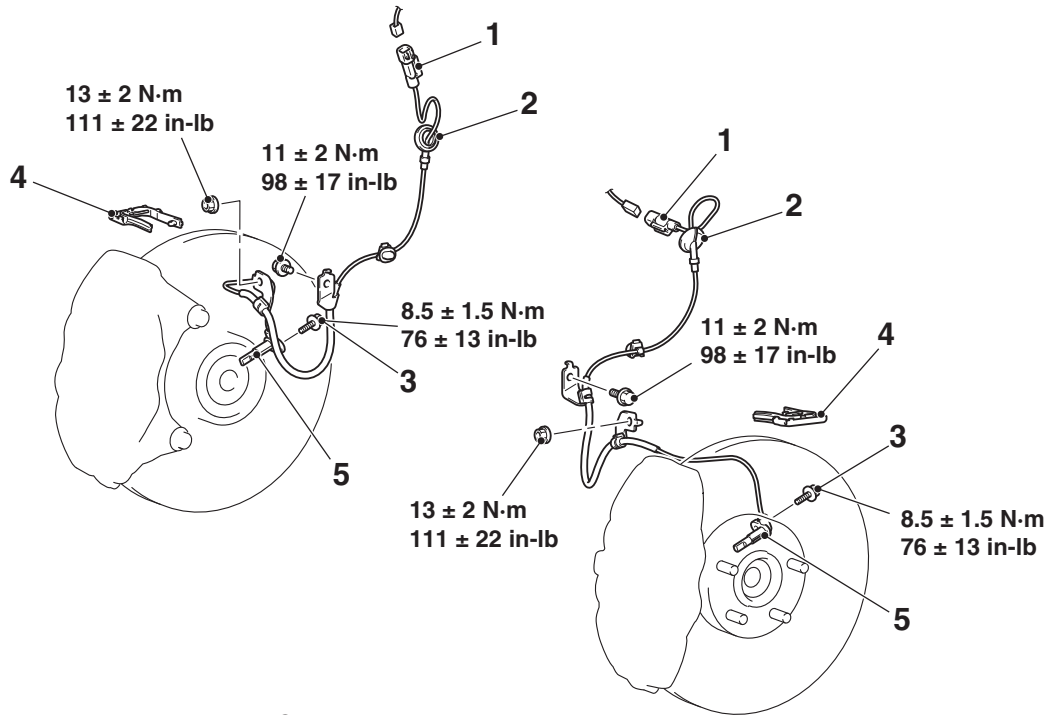

<Rear>

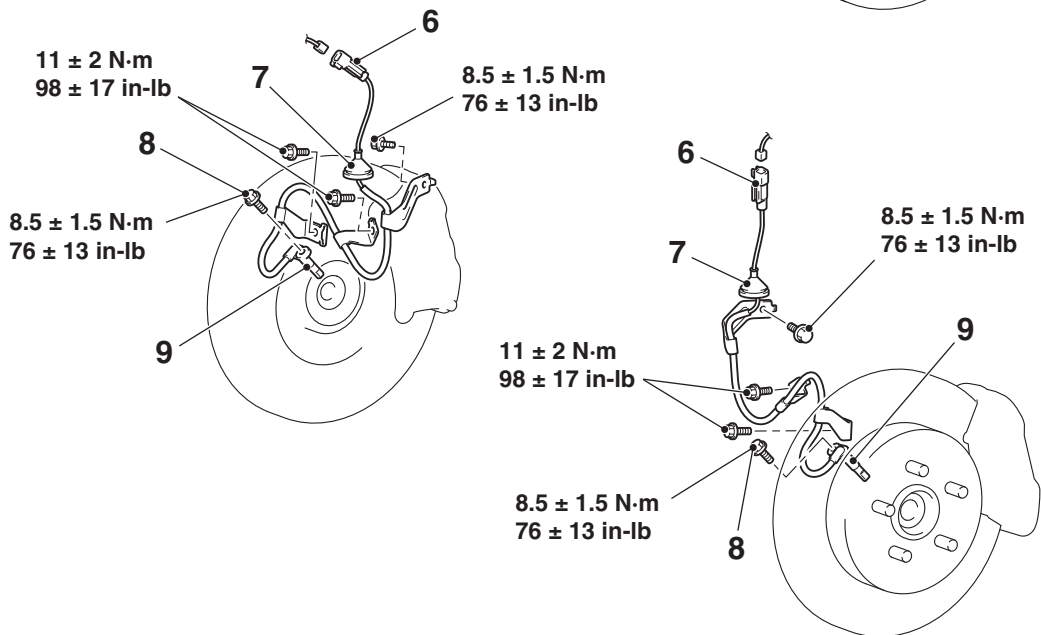

AC704283AB

Front wheel speed sensor removal steps

- >>C<< 1. Front wheel speed sensor connector
- >>A<< 2. Front wheel speed sensor grommet
- 3. Bolt (front wheel speed sensor and knuckle connection)
- >>B<< 4. Sensor harness clip
- 5. Front wheel speed sensor

Rear wheel speed sensor removal steps

- Trunk room front trim (Refer to GROUP 52A –Trim P.52A-12.)
- 6. Rear wheel speed sensor connector
- >>A<< 7. Rear wheel speed sensor grommet
- 8. Bolt (rear wheel speed sensor and knuckle assembly connection)
- 9. Rear wheel speed sensor

NOTE: The vehicle speed detection encoder is integrated with the front wheel bearing and the rear hub assembly, which cannot be disassembled.

INSTALLATION SERVICE POINTS

>>A<< FRONT WHEEL SPEED SENSOR GROMMET/REAR WHEEL SPEED SENSOR GROMMET INSTALLATION

Install the front wheel speed sensor grommet and the rear wheel speed sensor grommet to the body panel snugly as shown in the figure.

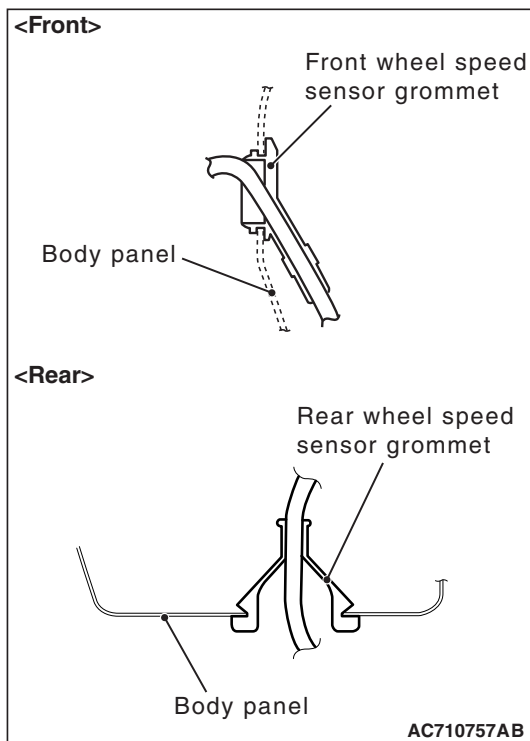

>>B<< SENSOR HARNESS CLIP INSTALLATION

As shown in the figure, align the edge of front wheel speed sensor marking with the edge of sensor wiring harness clip, then perform the installation.

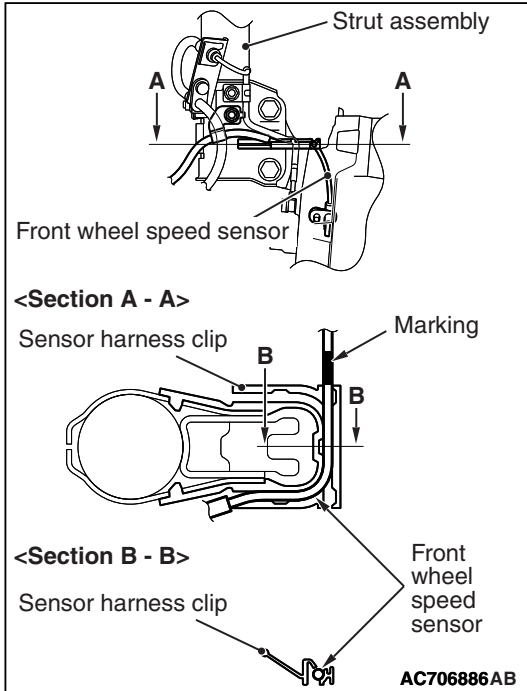

>>C<< FRONT WHEEL SPEED SENSOR CONNECTOR INSTALLATION

As shown in the figure, align the edge of front wheel speed sensor marking with the edge of clip, then perform the installation.

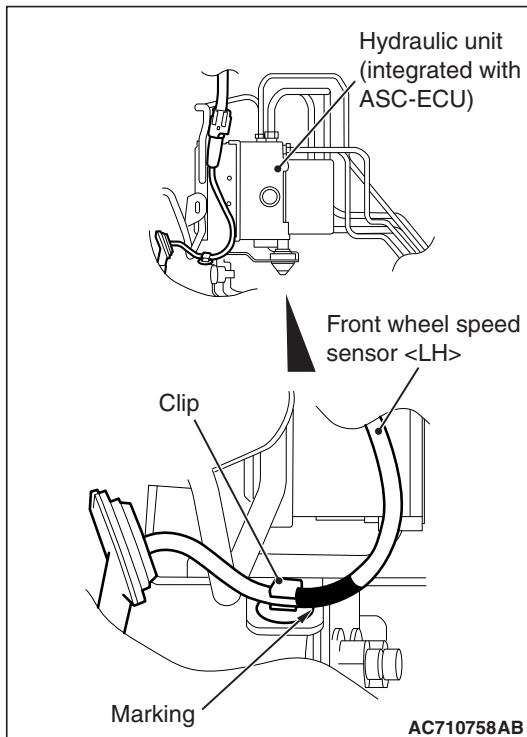

INSPECTION

WHEEL SPEED SENSOR CURRENT CHECK

⚠ CAUTION

Do not connect the battery terminals in reverse as the wheel speed sensor may be damaged.

1. Connect the circuit tester to the wheel speed sensor using the special tool extra fine probe (MB992006), and measure the sensor current as a single unit.

NOTE:

When measuring at the front wheel speed sensor

- Do not remove the front wheel speed sensor from the knuckle.

When measuring at the rear wheel speed sensor

- Do not remove the rear wheel speed sensor from the knuckle.

Standard value: 5.9 to 8.4 mA or 11.8 to 16.8 mA

2. If the measurement value is not within the standard value range, replace the wheel speed sensor with a new one.

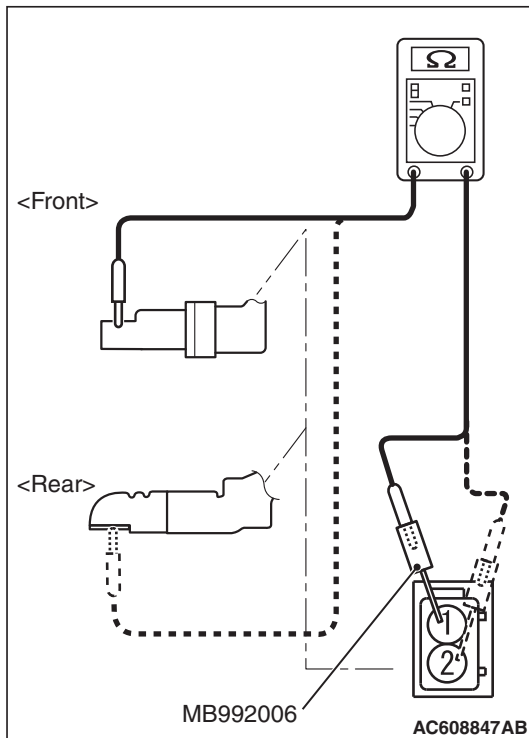
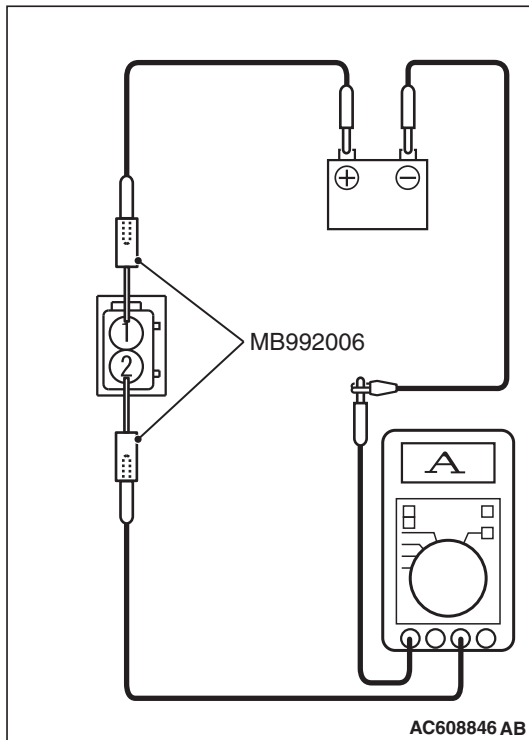

WHEEL SPEED SENSOR INSULATION CHECK

1. Connect the circuit tester to the wheel speed sensor using the special tool extra fine probe (MB992006), and measure the insulation resistance between terminal No. 1/2 and the wheel speed sensor body as a single unit.

Standard value: 5 MΩ or more

2. If the insulation resistance is not within the standard value range, replace the wheel speed sensor with a new one.

G AND YAW RATE SENSOR**REMOVAL AND INSTALLATION**

M1355004500204

CAUTION

- Do not use an impact wrench.
- Do not drop or shock the G and yaw rate sensor.
- When the G and yaw rate sensor is replaced, always carry out calibration to make ASC-ECU learn the neutral point. (Refer to [P.35C-287.](#))

Pre-removal and post-installation steps

Floor console side cover removal and installation (Refer to GROUP 52A –Floor Console Assembly [P.52A-10.](#))

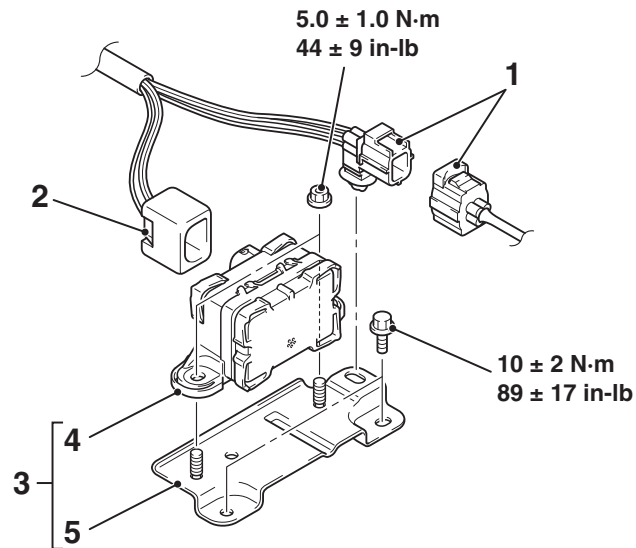

AC613540AB

Removal steps

1. Front O₂ sensor connector
2. G and yaw rate sensor connector

Removal steps (Continued)

3. G and yaw rate sensor and G and yaw rate sensor bracket
4. G and yaw rate sensor
5. G and yaw rate sensor bracket

STEERING WHEEL SENSOR

REMOVAL AND INSTALLATION

M1355005100221

CAUTION

- Always align the center of the clock spring before installing the steering wheel sensor. Otherwise, the sensor can be damaged.
- If the center of the clock spring is not correctly aligned, the steering wheel may not be turned fully or the cable inside the clock spring may be broken, causing the SRS air bag to be inoperative or operated incorrectly.
- Before removing the steering wheel assembly and driver's air bag module, always refer to GROUP 52B –Service Precautions P.52B-24 and Driver's Air bag Module and Clock Spring P.52B-413.
- When the steering wheel sensor is replaced, always carry out calibration to make ASC-ECU learn the neutral point. (Refer to P.35C-289.)

Pre-removal operation

- Position the front wheels in a straight ahead direction.
- Driver's air bag module removal (Refer to GROUP 52B – Driver's Air bag Module and Clock Spring P.52B-413.)
- Steering wheel assembly removal (Refer to GROUP 37 – Steering Wheel P.37-29.)
- Steering column upper cover and steering column lower cover removal (Refer to GROUP 37 –Steering Shaft P.37-33.)
- Paddle shift assembly removal (Refer to GROUP 37 – Steering Shaft P.37-33.) <Vehicles with paddle shift>

Post-installation operation

- Paddle shift assembly installation (Refer to GROUP 37 – Steering Shaft P.37-33.) <Vehicles with paddle shift>
- Steering column upper cover and steering column lower cover installation (Refer to GROUP 37 –Steering Shaft P.37-33.)
- Steering wheel assembly installation (Refer to GROUP 37 –Steering Wheel P.37-29.)
- Driver's air bag module installation (Refer to GROUP 52B –Driver's Air bag Module and Clock Spring P.52B-413.)
- Performing the steering wheel calibration (Refer to P.35C-289.)

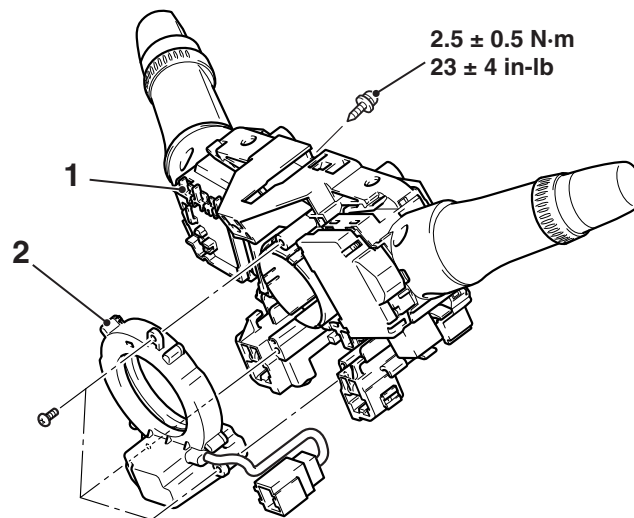

AC707231AB

Removal steps

- >>A<< 1. column switch assembly
>>A<< 2. Steering wheel sensor

INSTALLATION SERVICE POINT

>>A<< NEUTRAL POSITIONING OF STEERING WHEEL SENSOR

⚠ CAUTION

- Always align the center of the clock spring before installing the steering wheel sensor. Otherwise, the sensor can be damaged.
- If the center of the clock spring is not correctly aligned, the steering wheel may not be turned fully or the cable inside the clock spring may be broken, causing the SRS air bag to be inoperative or operated incorrectly.

1. Align the mating marks of the clock spring.

<Alignment of mating marks>

- (1) Turn the clock spring clockwise fully.
- (2) Turn the clock spring counterclockwise approximately three and 3/4 turns to align the mating marks.
- (3) Check that the white roller is visible from the window for checking the neutral point with the mating marks being aligned.

NOTE: If the white roller is invisible, the neutral point is

⚠ CAUTION *ned correctly.*

Always align three mating marks of the steering wheel sensor simultaneously as shown in the figure. If these mating marks are not aligned correctly, the steering wheel sensor may be damaged.

2. Align three mating marks of the steering wheel sensor simultaneously as shown in the figure.

<Alignment of mating marks>

- (1) Check the window for inspecting the neutral position of the steering wheel sensor. If the mating marks cannot be seen from the window, align the mating marks as shown in the figure.
- (2) Install the steering wheel sensor to the column switch assembly, maintaining the neutral position correctly.

NOTE: A new steering wheel sensor has a lock clip for preventing the rotation of (fixing) the steering wheel sensor. After installing the column switch assembly, remove this lock clip.

- (3) Install the column switch assembly to the vehicle, maintaining the neutral position correctly.

