

GROUP 13A

MULTIPOINT FUEL INJECTION (MFI)

CONTENTS

GENERAL INFORMATION	13A-2	FUEL PUMP OPERATION CHECK	13A-869
GENERAL SPECIFICATIONS	13A-5	MULTIPOINT FUEL INJECTION (MFI) RELAY CONTINUITY CHECK	13A-870
SERVICE SPECIFICATIONS	13A-6	FUEL PUMP RELAY CONTINUITY CHECK	13A-871
SEALANT AND ADHESIVE	13A-6	INJECTOR RELAY CONTINUITY CHECK ..	13A-873
SPECIAL TOOL	13A-7	THROTTLE ACTUATOR CONTROL MOTOR RELAY CONTINUITY CHECK	13A-873
MULTIPOINT FUEL INJECTION (MFI) DIAGNOSIS	13A-9	FUEL PUMP CIRCUIT RESISTOR CHECK	13A-874
TROUBLESHOOTING STRATEGY	13A-9	INTAKE AIR TEMPERATURE SENSOR CHECK	13A-874
DIAGNOSTIC FUNCTION	13A-9	ENGINE COOLANT TEMPERATURE SENSOR CHECK	13A-875
FAIL-SAFE FUNCTION REFERENCE TABLE	13A-44	HEATED OXYGEN SENSOR CHECK	13A-876
DIAGNOSTIC TROUBLE CODE CHART ..	13A-48	INJECTOR CHECK	13A-878
SYMPTOM CHART	13A-53	THROTTLE ACTUATOR CONTROL MOTOR CHECK	13A-879
DIAGNOSTIC TROUBLE CODE PROCEDURES	13A-56	ENGINE OIL CONTROL VALVE CHECK ..	13A-880
SYMPTOM PROCEDURES	13A-704	EVAPORATIVE EMISSION VENTILATION SOLENOID CHECK	13A-881
DATA LIST REFERENCE TABLE	13A-818	EVAPORATIVE EMISSION PURGE SOLENOID CHECK	13A-881
GENERAL SCAN TOOL (GST) MODE 01 REFERENCE TABLE	13A-834	INJECTOR	13A-882
ACTUATOR TEST REFERENCE TABLE ..	13A-840	REMOVAL AND INSTALLATION	13A-882
CHECK AT THE ENGINE CONTROL MODULE (ECM)	13A-841	THROTTLE BODY ASSEMBLY	13A-886
INSPECTION PROCEDURE USING AN OSCILLOSCOPE	13A-850	REMOVAL AND INSTALLATION	13A-886
ON-VEHICLE SERVICE	13A-859	ENGINE CONTROL RESISTOR	13A-887
COMPONENT LOCATION	13A-859	REMOVAL AND INSTALLATION	13A-887
THROTTLE BODY (THROTTLE VALVE AREA) CLEANING	13A-865	ENGINE CONTROL MODULE (ECM)	13A-888
FUEL PRESSURE TEST	13A-865	REMOVAL AND INSTALLATION	13A-888
HOW TO REDUCE PRESSURIZED FUEL PRESSURE	13A-868		

GENERAL INFORMATION

M1131000104929

The Multiport Fuel Injection System consists of sensors which detect the engine conditions, the ENGINE CONTROL MODULE (ECM) which controls the system based on signals from these sensors, and actuators which operate under the control of the ECM.

The ECM carries out activities such as fuel injection control, idle air control, and ignition timing control. In addition, the ECM is equipped with several diagnostic test modes which simplify troubleshooting when a problem develops.

FUEL INJECTION CONTROL

The injector drive times and injection timing are controlled so that the optimum air/fuel mixture is supplied to the engine to correspond to the continually-changing engine operation conditions. A single injector is mounted at the intake port of each cylinder. Fuel is sent under pressure from the fuel tank to the fuel injectors by the fuel pump, with the pressure being regulated by the fuel pressure regulator. The regulated fuel is distributed to each of the injectors.

Fuel injection is normally carried out once for each cylinder for every two rotations of the crankshaft. The firing order is 1-3-4-2. Each cylinder has a dedicated fuel injector. This is called multiport.

The ECM provides a richer air/fuel mixture by carrying out "open-loop" control when the engine is cold or operating under high load conditions in order to maintain engine performance. In addition, when the engine is under normal operating temperature after warming-up, the ECM controls the air/fuel mixture by using the heated oxygen sensor signal to carry out "closed-loop" control. The closed-loop control achieves the theoretical air/fuel mixture ratio where the catalytic converter can obtain the maximum cleaning performance.

THROTTLE VALVE OPENING CONTROL

This system electrically controls the opening of the throttle valve. The ECM detects the amount of travel of the accelerator pedal via the accelerator pedal position sensor, and controls the actuation of the throttle actuator control motor, which is mounted on the throttle body, in order to attain the target throttle valve opening that has been predetermined in accordance with driving conditions.

IDLE AIR CONTROL

The idle speed is kept at the optimum speed by controlling the amount of air that passes through the throttle valve in accordance with changes in idling conditions and engine load during idling.

The ECM drives the throttle actuator control motor to keep the engine running at the pre-set idle target speed in accordance with the engine coolant temperature and A/C and other electrical load. In addition, when the air conditioning switch is turned off and on while the engine is idling, the throttle actuator control motor adjusts the throttle valve pass-through air amount according to the engine load conditions to avoid fluctuations in the engine speed.

IGNITION TIMING CONTROL

The ignition power transistor located in the ignition primary circuit turns ON and OFF to control the primary current flow to the ignition coil. This controls the ignition timing to provide the optimum ignition timing with respect to the engine operating conditions. The ignition timing is determined by the ECM from engine speed, intake air volume, engine coolant temperature, and atmospheric pressure.

DIAGNOSTIC TEST MODE

- When a fault is detected in one of the sensors or actuators related to emission control, the Malfunction Indicator Lamp (SERVICE ENGINE SOON or Check Engine Lamp) illuminates to warn the driver.
- When a fault is detected in one of the sensors or actuators, a diagnostic trouble code corresponding to the fault is stored in the ECM.
- The RAM data inside the ECM that is related to the sensors and actuators can be read with the scan tool. In addition, the actuators can be controlled by scan tool MB991958 (M.U.T.-III sub assembly) under certain circumstances.

OTHER CONTROL FUNCTIONS

Fuel Pump Control

- Turns the fuel pump relay ON so that current is supplied to the fuel pump while the engine is cranking or running.
- In accordance with the driving conditions, switches the actuation condition of the fuel pump.

A/C Compressor Clutch Relay Control

- Turns the compressor clutch of the A/C ON and OFF.

Engine Oil Control Valve Control

- The ECM carries out the duty control of the engine oil control valve according to the operation condition. This varies the phase angle of the camshaft to optimize the valve timing.

Intake Charge Pressure Control

- Control the intake charge pressure by controlling the duty of the turbocharger wastegate solenoid.

Generator Output Current Control

- Prevent generator output current from increasing suddenly and idle speed from dropping at times such as when the headlights are turned on.

Evaporative Emission Purge Control

- (Refer to GROUP 17, Emission Control –Evaporative Emission Control System –General Information [P.17-73.](#))

MULTIPOINT FUEL INJECTION (MFI) SYSTEM DIAGRAM

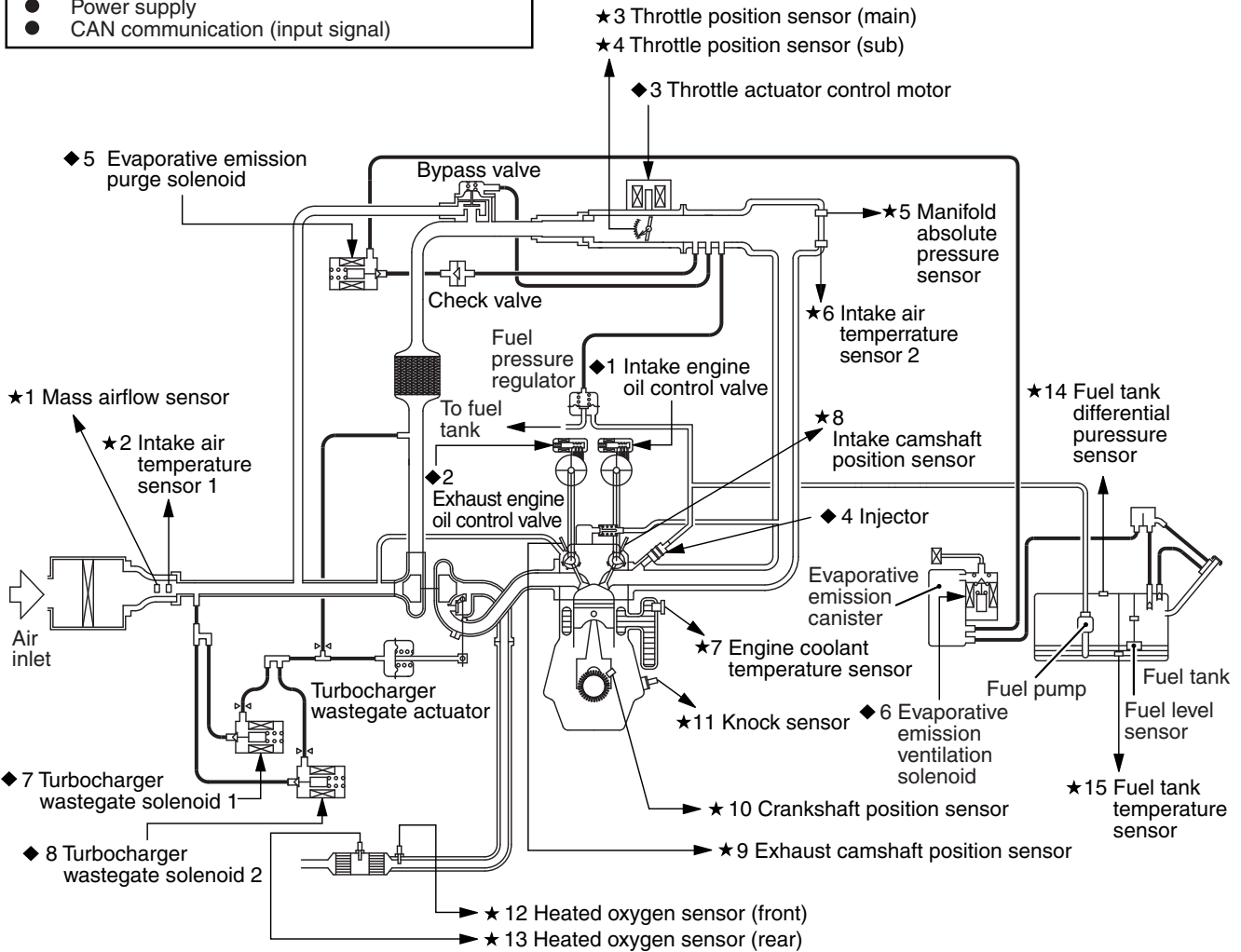
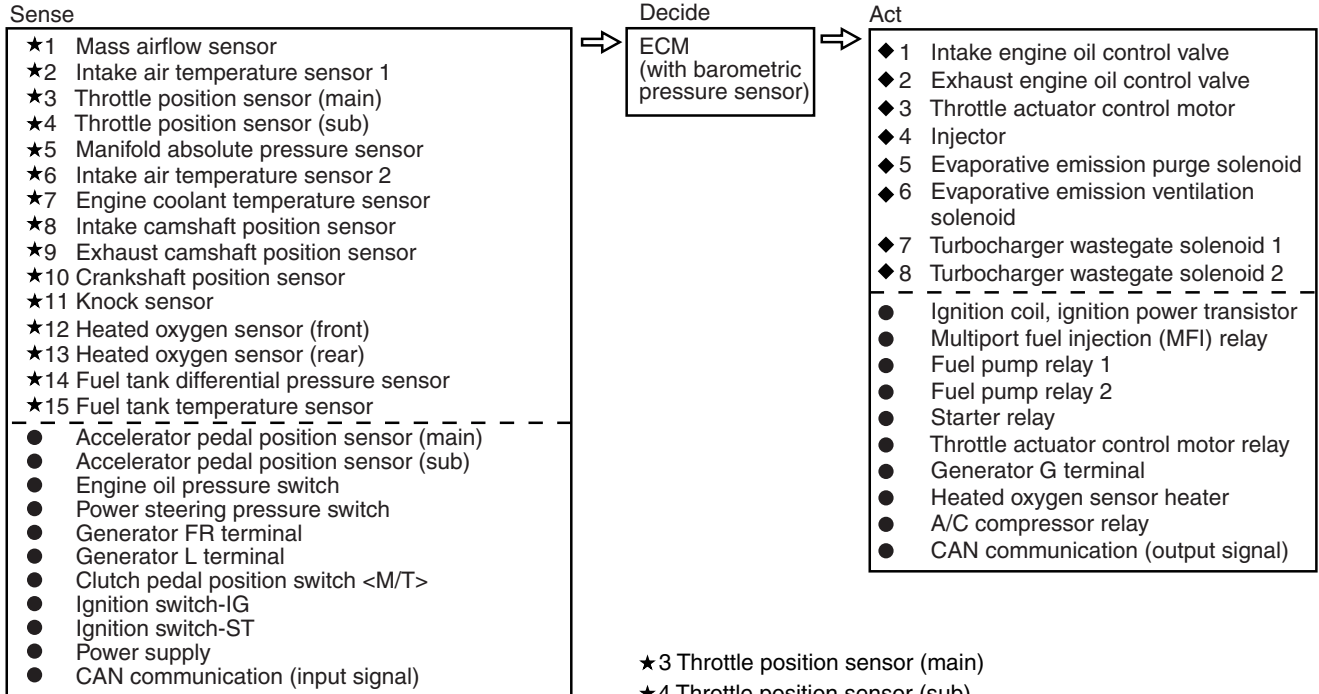

AK703839 AB

NOTE: For the vacuum routing, refer to GROUP 17, Emission Control –Vacuum Hoses –Vacuum Hose Routing P.17-69.

GENERAL SPECIFICATIONS

M1131000201574

ITEMS	SPECIFICATIONS	
Throttle body	Throttle bore mm (in.)	60 (2.36)
	Throttle position sensor	Hall element type
	Throttle actuator control motor	DC motor type, having brushes
Engine control module (ECM)	Identification model No.	E6T76477 <M/T> E6T76478 <TC-SST>
Sensors	Mass airflow sensor	Heat sensitizing type
	Barometric pressure sensor	Semi conductor type
	Intake air temperature sensor 1	Thermistor type
	Intake air temperature sensor 2	Thermistor type
	Engine coolant temperature sensor	Thermistor type
	Heated oxygen sensor	Zirconia type
	Accelerator pedal position sensor	Hall element type
	Camshaft position sensor	Magneto resistance element type
	Crankshaft position sensor	Magneto resistance element type
	Knock sensor	Piezoelectric type
	Power steering pressure switch	Contact switch type
	Manifold absolute pressure sensor	Semiconductor type
	Clutch pedal position switch <M/T>	Contact switch type
Actuators	Multiport fuel injection (MFI) relay	Contact switch type
	Fuel pump relay	Contact switch type
	Throttle actuator control motor relay	Contact switch type
	Injector type and number	Electromagnetic type, 4
	Injector identification mark	JME600G
	Engine oil control valve	Duty cycle type solenoid valve
	Evaporative emission purge solenoid	Duty cycle type solenoid valve
	Turbocharger wastegate solenoid	Duty cycle type solenoid valve
Fuel pressure regulator	Regulator pressure kPa (psi)	329 (48)

SERVICE SPECIFICATIONS

M1131000302154

ITEMS		STANDARD VALUE
Fuel pressure kPa (psi)	Vacuum hose disconnected	310 –345 (45 –50) at curb idle
	Vacuum hose connected	Approximately 260 (38) at curb idle
Intake air temperature sensor 1 resistance k Ω	-20° C (-4° F)	13 –17
	0° C (32° F)	5.4 –6.6
	20° C (68° F)	2.3 –3.0
	40° C (104° F)	1.0 –1.5
	60° C (140° F)	0.56 –0.76
	80° C (176° F)	0.31 –0.43
Intake air temperature sensor 2 resistance k Ω	-20° C (-4° F)	13 –18
	0° C (32° F)	5.1 –6.9
	20° C (68° F)	2.0 –3.0
	40° C (104° F)	0.9 –1.5
	60° C (140° F)	0.40 –0.78
	80° C (176° F)	0.23 –0.42
Engine coolant temperature sensor resistance k Ω	-20° C (-4° F)	14 –17
	0° C (32° F)	5.1 –6.5
	20° C (68° F)	2.1 –2.7
	40° C (104° F)	0.9 –1.3
	60° C (140° F)	0.48 –0.68
	80° C (176° F)	0.26 –0.36
Heated oxygen sensor output voltage V		0.6 –1.0
Heated oxygen sensor heater resistance Ω	Front	4.5 –8.0
	Rear	4.5 –8.0
Injector coil resistance Ω		10.5 –13.5 [at 20° C (68° F)]
Throttle actuator control motor coil resistance Ω		0.3 –80 [at 20° C (68° F)]
Fuel pump circuit resistor resistance Ω		0.45 –0.65 [at 20° C (68° F)]
Intake engine oil control valve coil resistance Ω		6.9 –7.9 [at 20° C (68° F)]
Exhaust engine oil control valve coil resistance Ω		6.9 –7.9 [at 20° C (68° F)]



SEALANT AND ADHESIVE

M1131000501490

ITEM	SPECIFIED SEALANT
Engine coolant temperature sensor threaded portion	LOCTITE 262, Three bond 1324N or equivalent

SPECIAL TOOL

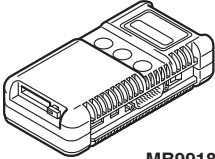
M1131000603396

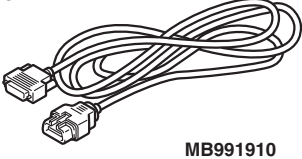
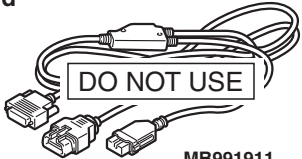
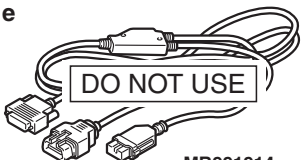
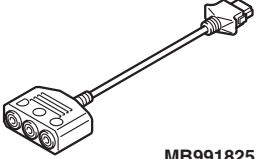
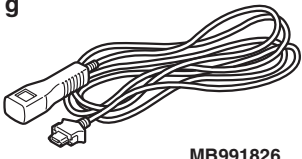
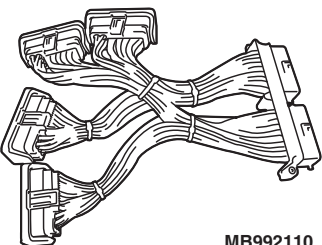
Tool	Tool number and name	Supersession	Application
<p>a</p>  <p>MB991824</p> <p>b</p>  <p>MB991827</p> <p>c</p>  <p>MB991910</p> <p>d</p>  <p>MB991911</p> <p>e</p>  <p>MB991914</p> <p>f</p>  <p>MB991825</p> <p>g</p>  <p>MB991826 MB991958</p>	<p>MB991958</p> <p>a. MB991824</p> <p>b. MB991827</p> <p>c. MB991910</p> <p>d. MB991911</p> <p>e. MB991914</p> <p>f. MB991825</p> <p>g. MB991826</p> <p>M.U.T.-III sub assembly</p> <p>a. Vehicle Communication Interface (V.C.I.)</p> <p>b. M.U.T.-III USB Cable</p> <p>c. M.U.T.-III Main Harness A (Vehicles with CAN communication system)</p> <p>d. M.U.T.-III Main Harness B (Vehicles without CAN communication system)</p> <p>e. M.U.T.-III Main Harness C (for Chrysler models only)</p> <p>f. M.U.T.-III Measurement Adapter</p> <p>g. M.U.T.-III Trigger Harness</p>	<p>MB991824-KIT</p> <p><i>NOTE: g: MB991826 M.U.T.-III Trigger Harness is not necessary when pushing V.C.I. ENTER key.</i></p>	<ul style="list-style-type: none"> • Reading diagnostic trouble code • MFI system inspection • Measurement of fuel pressure <p>CAUTION</p> <p>For vehicles with CAN communication, use M.U.T.-III main harness A to send simulated vehicle speed. If you connect M.U.T.-III main harness B instead, the CAN communication does not function correctly.</p>
 <p>MB992110</p>	<p>MB992110</p> <p>Power plant ECU check harness</p>	<p>–</p>	<ul style="list-style-type: none"> • Inspection using an oscilloscope • Inspection of the engine control module (ECM) terminal voltage check

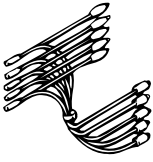
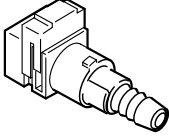
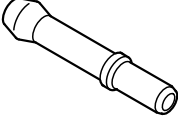
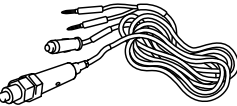
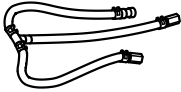
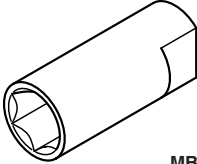
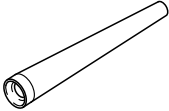
Tool	Tool number and name	Supersession	Application
	MB991709 Test harness	MB991709-01	Inspection using an oscilloscope
 MB991658	MB991658 Test harness	Tool not available	<ul style="list-style-type: none"> • Inspection using an oscilloscope • Inspection of throttle position sensor • Inspection of heated oxygen sensor • Inspection of engine oil control valve
 MB992049	MB992049	MB992049-01	Measurement of fuel pressure
 MB992001	MB992001	Hose adaptor	Measurement of fuel pressure
 MB991981	MB991981 Fuel pressure gauge set	Tool not available	Measurement of fuel pressure
 MB992076	MB992076	Injector test set	Measurement of fuel pressure
 MB992042	MB992042 Engine coolant temperature sensor wrench	-	Removal and installation of the engine coolant temperature sensor
 B992106	MB992106 O-ring installer	-	Installation of O-ring on injector injection nozzle side

MULTIPOINT FUEL INJECTION (MFI) DIAGNOSIS

TROUBLESHOOTING STRATEGY

M1131150002188

NOTE: If a DTC is erased, its "freeze frame" data will also be erased and system readiness test status will be reset. Store the "freeze frame" data before erasing the DTC.

Use these steps to plan your diagnostic strategy. If you follow them carefully, you will be sure to have exhausted most of the possible ways to find an MFI fault.

1. Gather as much information as possible about the complaint from the customer.
2. Verify that the condition described by the customer exists.
3. Check the vehicle for any MFI Diagnostic Trouble Code (DTC).
4. If you cannot verify the condition and there are no DTCs, the malfunction is intermittent. For information on how to cope with intermittent malfunctions, refer to GROUP 00, How to Use Troubleshooting/Inspection Service Points –How to Cope with Intermittent Malfunctions P.00-15.
5. If you can verify the condition but there are no DTCs, or the system cannot communicate with the scan tool, refer to the trouble symptom classification table.

6. If there is a DTC, store the number of the code, then erase the code from the memory using the scan tool.
7. Reconfirm the malfunction symptom and carry out a test drive with the drive cycle pattern.
8. If DTC is set again, carry out an inspection with appropriate diagnostic trouble code procedures.
9. If DTC is not set again, the malfunction is intermittent. For information on how to cope with intermittent malfunctions, refer to GROUP 00, How to Use Troubleshooting/Inspection Service Points –How to Cope with Intermittent Malfunctions P.00-15.
10. After repairs are completed, conduct a road test duplicating the complaint set conditions to confirm the malfunction has been corrected.

NOTE: If the engine control module (ECM) is replaced, Immobilizer Encrypted Code Registration should be carried out, refer to GROUP 42B, ID Code Registration Necessity Judgment Table <Vehicles with KOS> P.42B-11 or GROUP 42C, ID Codes Registration Judgment Table <Vehicles with WCM> P.42C-9.

DIAGNOSTIC FUNCTION

M1131155503738

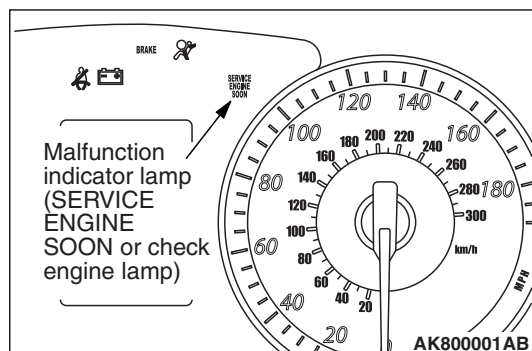

MALFUNCTION INDICATOR LAMP (SERVICE ENGINE SOON OR CHECK ENGINE LAMP)

Among the on-board diagnostic items, Malfunction Indicator Lamp (SERVICE ENGINE SOON or Check Engine Lamp) illuminates to notify the driver of an emission control malfunction. However, when an irregular signal returns to normal and the engine control module judges that it has returned to normal, the Malfunction Indicator Lamp (SERVICE ENGINE SOON or Check Engine Lamp) will switch off.

There are two methods for checking the Malfunction Indicator Lamp (SERVICE ENGINE SOON or Check Engine Lamp) burn out: When the ignition switch is in ON position, the Malfunction Indicator Lamp (SERVICE ENGINE SOON or Check Engine Lamp) is illuminated, and then extinguished few seconds later. When the ignition switch is in ON position and the engine starts, the Malfunction Indicator Lamp (SERVICE ENGINE SOON or Check Engine Lamp) is extinguished.

NOTE: When the Transmission Control Module (TCM) detects malfunctions related to the TC-SST, the Malfunction indicator Lamp (SERVICE ENGINE SOON or Check Engine Lamp) is also illuminated.

Items Indicated by the Malfunction Indicator Lamp (SERVICE ENGINE SOON or Check Engine Lamp)

DTC	ITEM
P0010	Intake engine oil control valve circuit
P0011	Intake variable valve timing system target error
P0013	Exhaust engine oil control valve circuit
P0014	Exhaust variable valve timing system target error
P0016	Crankshaft/camshaft (intake) position sensor phase problem
P0017	Crankshaft/camshaft (exhaust) position sensor phase problem
P0031	Heated oxygen sensor (front) heater circuit low
P0032	Heated oxygen sensor (front) heater circuit high
P0037	Heated oxygen sensor (rear) heater circuit low
P0038	Heated oxygen sensor (rear) heater circuit high
P0069	Abnormal correlation between manifold absolute pressure sensor and barometric pressure sensor
P0096*1	Intake air temperature circuit range/performance problem (sensor 2)
P0097*1	Intake air temperature circuit low input (sensor 2)
P0098*1	Intake air temperature circuit high input (sensor 2)
P0101*1	Mass airflow circuit range/performance problem
P0102*1	Mass airflow circuit low input
P0103*1	Mass airflow circuit high input
P0106	Manifold absolute pressure circuit range/performance problem
P0107	Manifold absolute pressure circuit low input
P0108	Manifold absolute pressure circuit high input
P0111*1	Intake air temperature circuit range/performance problem (sensor 1)
P0112*1	Intake air temperature circuit low input (sensor 1)
P0113*1	Intake air temperature circuit high input (sensor 1)
P0116*1	Engine coolant temperature circuit range/performance problem
P0117*1	Engine coolant temperature circuit low input
P0118*1	Engine coolant temperature circuit high input
P0122*1	Throttle position sensor (main) circuit low input
P0123*1	Throttle position sensor (main) circuit high input
P0125*1	Insufficient coolant temperature for closed loop fuel control
P0128	Coolant thermostat (coolant temperature below thermostat regulating temperature)
P0131	Heated oxygen sensor (front) circuit low voltage
P0132	Heated oxygen sensor (front) circuit high voltage
P0133	Heated oxygen sensor (front) circuit slow response
P0134*1	Heated oxygen sensor (front) circuit no activity detected
P0137	Heated oxygen sensor (rear) circuit low voltage

DTC	ITEM
P0138	Heated oxygen sensor (rear) circuit high voltage
P0139	Heated oxygen sensor (rear) circuit slow response
P0140	Heated oxygen sensor (rear) circuit no activity detected
P0171	System too lean
P0172	System too rich
P0181	Fuel tank temperature sensor circuit range/performance
P0182	Fuel tank temperature sensor circuit low input
P0183	Fuel tank temperature sensor circuit high input
P0201	Injector circuit –cylinder 1
P0202	Injector circuit –cylinder 2
P0203	Injector circuit –cylinder 3
P0204	Injector circuit –cylinder 4
P0222*1	Throttle position sensor (sub) circuit low input
P0223*1	Throttle position sensor (sub) circuit high input
P0234	Turbocharger wastegate system malfunction
P0243	Turbocharger wastegate solenoid 1 circuit
P0247	Turbocharger wastegate solenoid 2 circuit
P0300*2	Random/multiple cylinder misfire detected
P0301*2	Cylinder 1 misfire detected
P0302*2	Cylinder 2 misfire detected
P0303*2	Cylinder 3 misfire detected
P0304*2	Cylinder 4 misfire detected
P0327	Knock sensor circuit low
P0328	Knock sensor circuit high
P0335*1	Crankshaft position sensor circuit
P0340*1	Intake camshaft position sensor circuit
P0365*1	Exhaust camshaft position sensor circuit
P0420	Warm up catalyst efficiency below threshold
P0441	Evaporative emission control system incorrect purge flow
P0442	Evaporative emission control system leak detected (small leak)
P0443	Evaporative emission control system purge control valve circuit
P0446	Evaporative emission control system vent control circuit
P0450	Evaporative emission control system pressure sensor malfunction
P0451	Evaporative emission control system pressure sensor range/performance
P0452	Evaporative emission control system pressure sensor low input
P0453	Evaporative emission control system pressure sensor high input
P0455	Evaporative emission control system leak detected (gross leak)
P0456	Evaporative emission control system leak detected (very small leak)

DTC	ITEM
P0461	Fuel level sensor (main) circuit range/performance
P0462	Fuel level sensor circuit low input
P0463	Fuel level sensor circuit high input
P0500*1	Vehicle speed signal malfunction
P0506	Idle control system RPM lower than expected
P0507	Idle control system RPM higher than expected
P050B	Ignition timing retard insufficient
P0551	Power steering pressure switch circuit range/performance
P0554	Power steering pressure switch circuit intermittent
P0603*1	EEPROM malfunction
P0606*1	Engine control module main processor malfunction
P0630*1	Vehicle Identification Number (VIN) malfunction
P0638*1	Throttle actuator control motor circuit range/performance
P0642*1	Throttle position sensor power supply
P0657*1	Throttle actuator control motor relay circuit malfunction
P1233*1	Throttle position sensor (main) plausibility
P1234*1	Throttle position sensor (sub) plausibility
P1235*1	Mass airflow sensor plausibility
P1236*1	A/D converter
P1237*1	Accelerator pedal position sensor plausibility
P1238*1	Mass airflow sensor plausibility (torque monitor)
P1239*1	Engine RPM plausibility
P1241*1	Torque monitor
P1506	Idle control system RPM lower than expected at low temperature
P1507	Idle control system RPM higher than expected at low temperature
P1590*1	TCM to ECM communication error in torque reduction request <TC-SST>
P1603*1	Battery backup circuit malfunction
P1676*1	Variant coding
P2066	Fuel level sensor (sub) circuit range/performance
P2096	Post catalyst fuel trim system too lean
P2097	Post catalyst fuel trim system too rich
P2100*1	Throttle actuator control motor circuit (open)
P2101*1	Throttle actuator control motor magneto malfunction
P2122*1	Accelerator pedal position sensor (main) circuit low input
P2123*1	Accelerator pedal position sensor (main) circuit high input
P2127*1	Accelerator pedal position sensor (sub) circuit low input

DTC	ITEM
P2128*1	Accelerator pedal position sensor (sub) circuit high input
P2135*1	Throttle position sensor (main and sub) range/performance problem
P2138*1	Accelerator pedal position sensor (main and sub) range/performance problem
P2195	Heated oxygen sensor (front) inactive
P2228*1	Barometric pressure circuit low input
P2229*1	Barometric pressure circuit high input
P2252	Heated oxygen sensor offset circuit low voltage
P2253	Heated oxygen sensor offset circuit high voltage
U0101*1	TC-SST-ECU time-out <TC-SST>
U0121*1	ASC-ECU time-out
U0141*1	ETACS-ECU time-out
U1180*1	Combination meter time-out

NOTE: If the Malfunction Indicator Lamp (SERVICE ENGINE SOON or Check Engine Lamp) illuminates because of a malfunction of the engine control module (ECM), communication between the scan tool MB991958 (M.U.T.-III sub assembly) and the ECM is impossible. In this case, the diagnostic trouble code cannot be read.

*NOTE: After the ECM has detected a malfunction, the Malfunction Indicator Lamp (SERVICE ENGINE SOON or Check Engine Lamp) illuminates when the engine is next turned on and the same malfunction is re-detected. However, for items marked with a "*1" in the diagnostic trouble code number column, the Malfunction Indicator Lamp (SERVICE ENGINE SOON or Check Engine Lamp) illuminates only on the first detection of the malfunction.*

*NOTE: The codes marked with a "*2" in the diagnostic trouble code number column have the following two conditions for illuminating the Malfunction Indicator Lamp (SERVICE ENGINE SOON or Check Engine Lamp).*

- In case that the misfire causing the damaged catalyst is detected, the Malfunction Indicator Lamp (SERVICE ENGINE SOON or Check Engine Lamp) is illuminated at the time.
- In case that the misfire deteriorating the exhaust gas is detected, the Malfunction Indicator Lamp (SERVICE ENGINE SOON or Check Engine Lamp) is illuminated when the same malfunction is redetected after the next engine start.

NOTE: After the Malfunction Indicator Lamp (SERVICE ENGINE SOON or Check Engine Lamp) illuminates, it will be switched off under the following conditions.

- When the ECM monitored the powertrain malfunction three times* and met set condition requirements, it detected no malfunction. *: In this case, "one time" indicates from engine start to next engine start.
- For misfiring or a fuel trim malfunction, when driving conditions (engine speed, engine coolant temperature, etc.) are similar to those when the malfunction was first recorded.
- The illuminated MIL for the vehicle identification number related faults is extinguished when the vehicle identification number is detected.

NOTE: Sensor 1 of the heated oxygen sensor indicates the sensor mounted at a position closest to the engine, and sensor 2 of the heated oxygen sensor indicates the sensor mounted at the position second closest to the engine.

HOW TO CONNECT THE SCAN TOOL (M.U.T.-III)

Required Special Tools:

- MB991958: Scan Tool (M.U.T.-III Sub Assembly)
 - MB991824: V.C.I.
 - MB991827: USB Cable
 - MB991910: Main Harness A

⚠ CAUTION

To prevent damage to scan tool MB991958, always turn the ignition switch to the "LOCK" (OFF) position before connecting or disconnecting scan tool MB991958.

1. Ensure that the ignition switch is at the "LOCK" (OFF) position.
2. Start up the personal computer.
3. Connect special tool MB991827 to special tool MB991824 and the personal computer.
4. Connect special tool MB991910 to special tool MB991824.
5. Connect special tool MB991910 to the data link connector.
6. Turn the power switch of special tool MB991824 to the "ON" position.

NOTE: When the special tool MB991824 is energized, special tool MB991824 indicator light will be illuminated in a green color.

7. Start the M.U.T.-III system on the personal computer.

NOTE: Disconnecting the scan tool MB991958 is the reverse of the connecting sequence, making sure that the ignition switch is at the "LOCK" (OFF) position.

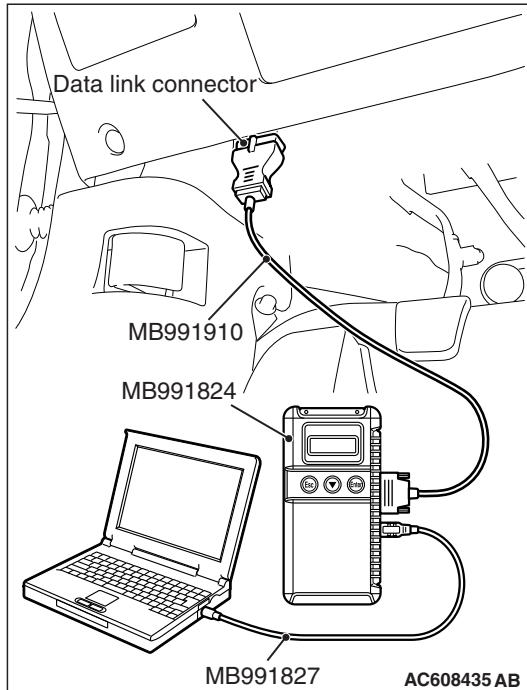

HOW TO READ AND ERASE DIAGNOSTIC TROUBLE CODES.

Required Special Tools:

- MB991958: Scan Tool (M.U.T.-III Sub Assembly)
 - MB991824: V.C.I.
 - MB991827: USB Cable
 - MB991910: Main Harness A

⚠ CAUTION

To prevent damage to scan tool MB991958, always turn the ignition switch to the "LOCK" (OFF) position before connecting or disconnecting scan tool MB991958.

1. Connect scan tool MB991958 to the data link connector.
2. Turn the ignition switch to the "ON" position.
3. Select "System select."
4. Choose "from 2006 MY" under "MODEL YEAR".
5. Check that "Vehicle Information" contents are correct.
6. Choose "MFI".
7. Select "Diagnostic Trouble Code"
8. If a DTC is set, it is shown.
9. Choose "Erase DTCs" to erase the DTC.

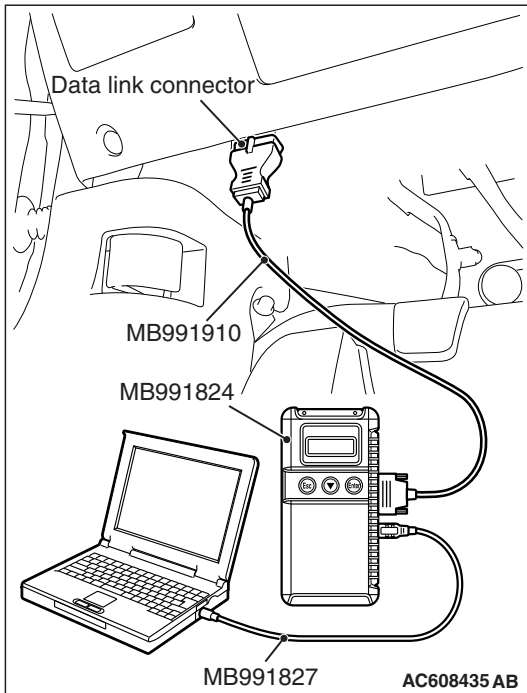

HOW TO READ DATA LIST

Required Special Tools:

- MB991958: Scan Tool (M.U.T.-III Sub Assembly)
 - MB991824: V.C.I.
 - MB991827: USB Cable
 - MB991910: Main Harness A

⚠ CAUTION

To prevent damage to scan tool MB991958, always turn the ignition switch to the "LOCK" (OFF) position before connecting or disconnecting scan tool MB991958.

1. Connect scan tool MB991958 to the data link connector.
2. Turn the ignition switch to the "ON" position.
3. Select "System select."
4. Choose "from 2006 MY" under "MODEL YEAR".
5. Check that "Vehicle Information" contents are correct.
6. Choose "MFI".
7. Select "Data List."
8. Choose an appropriate item and select the "OK" button.

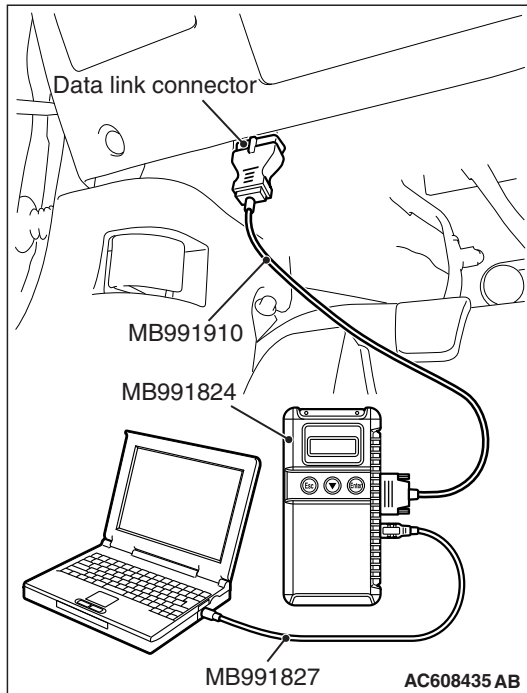

HOW TO PERFORM ACTUATOR TEST

Required Special Tools:

- MB991958: Scan Tool (M.U.T.-III Sub Assembly)
 - MB991824: V.C.I.
 - MB991827: USB Cable
 - MB991910: Main Harness A

⚠ CAUTION

To prevent damage to scan tool MB991958, always turn the ignition switch to the "LOCK" (OFF) position before connecting or disconnecting scan tool MB991958.

1. Connect scan tool MB991958 to the data link connector.
2. Turn the ignition switch to the "ON" position.
3. Select "System select."
4. Choose "from 2006 MY" under "MODEL YEAR".
5. Check that "Vehicle Information" contents are correct.
6. Choose "MFI".
7. Select "Actuator Test."
8. Choose an appropriate item and select the "OK" button.

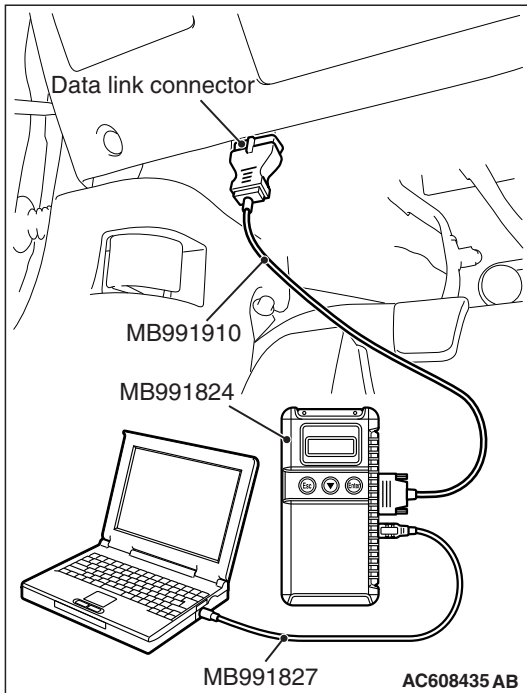

HOW TO DIAGNOSE THE CAN BUS LINES

Required Special Tools:

- MB991958: Scan Tool (M.U.T.-III Sub Assembly)
 - MB991824: V.C.I.
 - MB991827: USB Cable
 - MB991910: Main Harness A

⚠ CAUTION

To prevent damage to scan tool MB991958, always turn the ignition switch to the "LOCK" (OFF) position before connecting or disconnecting scan tool MB991958.

1. Connect scan tool MB991958 to the data link connector.
2. Turn the ignition switch to the "ON" position.
3. Select "CAN bus diagnosis" from the start-up screen.
4. When the vehicle information is displayed, confirm that it matches the vehicle whose CAN bus lines will be diagnosed.
 - If they matches, go to step 8.
 - If not, go to step 5.
5. Select the "view vehicle information" button.
6. Enter the vehicle information and select the "OK" button.
7. When the vehicle information is displayed, confirm again that it matches the vehicle whose CAN bus lines will be diagnosed.
 - If they matches, go to step 8.
 - If not, go to step 5.
8. Select the "OK" button.
9. When the optional equipment screen is displayed, choose the one which the vehicle is fitted with, and then select the "OK" button.

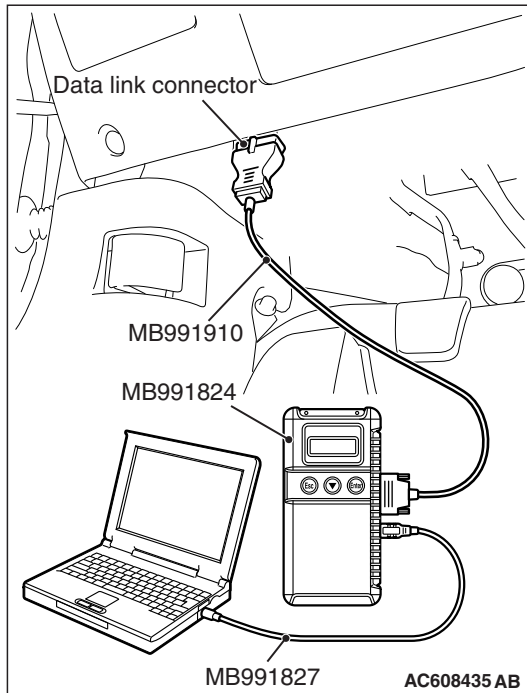

HOW TO READ PROVISIONAL DIAGNOSTIC TROUBLE CODES

Required Special Tools:

- MB991958: Scan Tool (M.U.T.-III Sub Assembly)
 - MB991824: V.C.I.
 - MB991827: USB Cable
 - MB991910: Main Harness A

If detecting the malfunction during the first drive cycle, the ECM temporarily stores the diagnosis code as the provisional diagnosis code. If detecting the same malfunction during the next drive cycle, the ECM determines that the malfunction exists. The ECM outputs the diagnosis code. On Scan Tool MB991958, it is possible to display the stored provisional diagnosis code which the ECM had detected during the first drive cycle. This makes it possible to confirm in one drive cycle whether the malfunction could happen again after the repair.

CONFIRMATION METHOD

CAUTION

To prevent damage to scan tool MB991958, always turn the ignition switch to the "LOCK" (OFF) position before connecting or disconnecting scan tool MB991958.

1. Connect scan tool MB991958 to the data link connector.
2. Turn the ignition switch to the "ON" position.
3. Select "System select."
4. Choose "from 2006 MY" under "MODEL YEAR".
5. Check that "Vehicle Information" contents are correct.
6. Choose "MFI".
7. Select "Special Function" from MFI Screen.
8. Select "Provisional DTCs" from Special Function Screen.

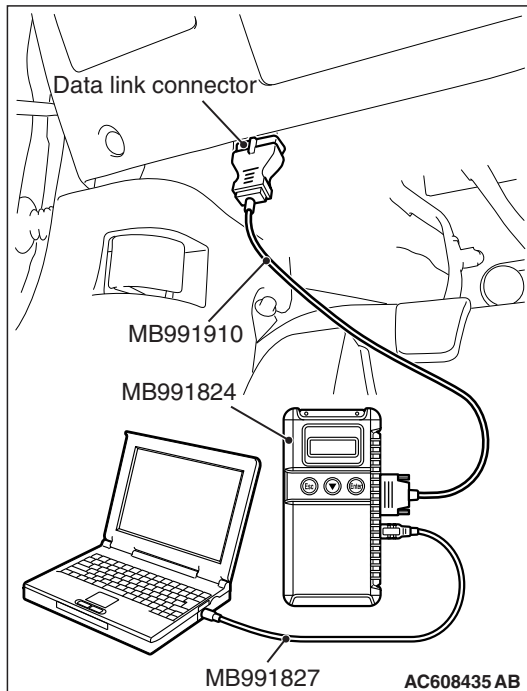

PERMANENT DTC

The permanent DTC(PDTC) is stored in the EEPROM of the engine control module (ECM) as the permanent status, which checks that the malfunction of the emission related components/ the system has not been repaired yet. When detecting the malfunction necessary to illuminate the malfunction indicator lamp (SERVICE ENGINE SOON or Check Engine Lamp), the ECM illuminates the MIL and stores the appropriate DTC as the permanent DTC in the EEPROM concurrently. The usual DTC is stored in the EEPROM aside from this. The ECM can store up to 6 PDTCs. The ECM, therefore, cannot store the 7th and subsequent PDTCs. If the temporary malfunction causes the malfunction indicator lamp to be illuminated and then the reinstatement during the subsequent driving causes it to be extinguished, the PDTC is erased. Also if the ECM checks that the DTC malfunction is fixed during the driving after the DTC repair is completed, the PDTC is erased. The permanent DTC, however, is not erased by disconnecting the battery terminal or erasing with the scan tool (M.U.T-III). The permanent DTC can be erased if all readiness statuses are erased or not completed at the time of reprogramming the ECM. If must be erased while the vehicle is repaired, the PDTC can be erased by the procedures shown below. If must be erased because of the failure to pass the Inspection and Maintenance (I/M) test, the permanent DTC can also be erased by the following procedure:

PROCEDURES FOR ERASING PERMANENT DTC

1. Check that the DTC is not stored. If the DTC is stored, perform the DTC troubleshooting, then repair the DTC.
NOTE: The order of step 2 and 3 can be exchanged.
2. Drive the vehicle at least once under the conditions satisfying all the following requirements:
 - The total driving (engine running) time must be more than 10 consecutive minutes.
 - More than 30 seconds of idling must be included in the driving
 - More than 5 consecutive minutes of driving at more than 40 km/h (25 mph) must be included in the driving.
3. Drive the vehicle at least two times in the drive cycle pattern suitable for the permanent DTC. (Refer to OBD-II DRIVE CYCLE for the drive cycle pattern.) If the DTC does not have the drive cycle pattern, start and stop the engine. Wait 15 seconds or more to start again after the stop. Repeat at least 2 times.
4. Restart and stop the engine.
5. Check that the permanent DTC is erased. If the permanent DTC is not erased, check the DTC or the provisional DTC. If the malfunction code is stored, repair the DTC. Try to erase the permanent DTC again (from Step 1 to 5). If the malfunction code is not stored, the drive cycle pattern (Step 3) monitoring the malfunction can possibly be insufficient.

MODE 6 REFERENCE TABLE

The engine control module (ECM) monitors the condition of emission control system.

By selecting MODE 6 using scan tool, Test Result and Limit Value (minimum) *1 or (maximum) *2 about the main items of emission control system which ECM monitors can be confirmed. The value at the last monitoring is output by ECM as a test result.

ON-BOARD DIAGNOSTIC MONITOR ID	STANDARDIZED / MANUFACTURER DEFINE TEST ID	MONITORING ITEM	SIMPLE TECHNICAL DESCRIPTION	CONVERSION COEFFICIENT IN USING GENERAL SCAN TOOL
01	81	Oxygen Sensor Monitor Bank 1 –Sensor 1 Rich/Lean Switching frequency	ECM monitors the deteriorated condition of the heated oxygen sensor (front) by checking the rich/lean switching frequency of the heated oxygen sensor (front).	× 1 count
02	08	Oxygen Sensor Monitor Bank 1 –Sensor 2 Maximum Sensor Voltage for Test Cycle	ECM checks the output voltage of the heated oxygen sensor (rear) in order to monitor whether the heated oxygen sensor (rear) outputs the rich signal.	× 0.122 mV
	82	Oxygen Sensor Monitor Bank 1 –Sensor 2 Output Voltage change	ECM checks the output voltage of the heated oxygen sensor (rear) in order to monitor whether the heated oxygen sensor (rear) output is stuck.	× 0.122 mV
	05	Oxygen Sensor Monitor Bank 1 –Sensor 2 Rich To Lean Sensor Switch Time	ECM checks the rich to lean switching time of the heated oxygen sensor (rear) in order to monitor the response of the heated oxygen sensor (rear).	× 1 msec
	88	Oxygen Sensor Monitor Bank 1 –Sensor 2 Output Voltage drop slope	ECM checks the output voltage drop slope of the heated oxygen sensor (rear) in order to monitor the response of the heated oxygen sensor (rear).	× 1 msec
21	83	Catalyst Monitor Bank 1 Frequency ratio between Front- and Rear-Oxygen Sensors	ECM monitors the deterioration of catalyst by the output frequency ratio between heated oxygen sensor (front) and heated oxygen sensor (rear).	× 0.0039

ON-BOARD DIAGNOSTIC MONITOR ID	STANDARDIZED / MANUFACTURER DEFINE TEST ID	MONITORING ITEM	SIMPLE TECHNICAL DESCRIPTION	CONVERSION COEFFICIENT IN USING GENERAL SCAN TOOL
35	89	VVT Monitor Bank 1 (L4-IN) Cam Phase Angle Deviation (between target and actual position)	ECM monitors the deviation between the intake camshaft target phase angle and the intake camshaft actual phase angle.	× 0.01°
36	89	VVT Monitor Bank 2 (L4-EX) Cam Phase Angle Deviation (between target and actual position)	ECM monitors the deviation between the exhaust camshaft target phase angle and the exhaust camshaft actual phase angle.	× 0.01°
39	85	EVAP Monitor (Cap off) Pressure drop during de-pressurizing	ECM monitors the leak of fuel evaporation gas by checking whether the pressure can be reduced (the amount of pressure reduction) using the fuel tank differential pressure sensor after sealing the fuel tank and the fuel line.	× 0.0117 kPa
3B	85	EVAP Monitor (0.040") Pressure rise during airtight condition	After ECM vacuumizes the fuel tank and the fuel line and then the specified time is passed, ECM monitors the leak of fuel evaporation gas through the fuel tank differential pressure sensor to check the reduction of vacuum in the fuel tank.	× 0.0117 kPa
3C	85	EVAP Monitor (0.020") Pressure rise during airtight condition	After ECM vacuumizes the fuel tank and the fuel line and then the specified time is passed, ECM monitors the leak of fuel evaporation gas through the fuel tank differential pressure sensor to check the reduction of vacuum in the fuel tank.	× 0.0117 kPa

**MULTIPOINT FUEL INJECTION (MFI)
MULTIPOINT FUEL INJECTION (MFI) DIAGNOSIS**

13A-23

ON-BOARD DIAGNOSTIC MONITOR ID	STANDARDIZED / MANUFACTURER DEFINED TEST ID	MONITORING ITEM	SIMPLE TECHNICAL DESCRIPTION	CONVERSION COEFFICIENT IN USING GENERAL SCAN TOOL
A2	0B	Mis-Fire Cylinder 1 Data EWMA Misfire Counts For Last 10 Driving Cycles	ECM monitors angular acceleration of crankshaft and detect misfire. EWMA (Exponential Weighted Moving Average) misfire counts for last 10 driving cycles.	× 1 count
	0C	Mis-Fire Cylinder 1 Data Misfire Counts For Last/Current Driving Cycle	ECM monitors angular acceleration of crankshaft and detect misfire. Misfire counts for last/current driving cycle.	× 1 count
A3	0B	Mis-Fire Cylinder 2 Data EWMA Misfire Counts For Last 10 Driving Cycles	ECM monitors angular acceleration of crankshaft and detect misfire. EWMA (Exponential Weighted Moving Average) misfire counts for last 10 driving cycles.	× 1 count
	0C	Mis-Fire Cylinder 2 Data Misfire Counts For Last/Current Driving Cycle	ECM monitors angular acceleration of crankshaft and detect misfire. Misfire counts for last/current driving cycle.	× 1 count
A4	0B	Mis-Fire Cylinder 3 Data EWMA Misfire Counts For Last 10 Driving Cycles	ECM monitors angular acceleration of crankshaft and detect misfire. EWMA (Exponential Weighted Moving Average) misfire counts for last 10 driving cycles.	× 1 count
	0C	Mis-Fire Cylinder 3 Data Misfire Counts For Last/Current Driving Cycle	ECM monitors angular acceleration of crankshaft and detect misfire. Misfire counts for last/current driving cycle.	× 1 count
A5	0B	Mis-Fire Cylinder 4 Data EWMA Misfire Counts For Last 10 Driving Cycles	ECM monitors angular acceleration of crankshaft and detect misfire. EWMA (Exponential Weighted Moving Average) misfire counts for last 10 driving cycles.	× 1 count
	0C	Mis-Fire Cylinder 4 Data Misfire Counts For Last/Current Driving Cycle	ECM monitors angular acceleration of crankshaft and detect misfire. Misfire counts for last/current driving cycle.	× 1 count

*NOTE: *1: Minimum value: The test fails if test value is less than this value.*

*NOTE: *2: Maximum value: The test fails if test value is greater than this value.*

NOTE: When not finishing the monitor of the driving cycle for the request of On-Board Monitoring Test Request, the ECM outputs the stored latest monitor test result.

NOTE: When the monitored test results are erased by the battery disconnection and so on, the ECM outputs the values in hexadecimal of "0000" or "FFFF", otherwise it outputs abnormal values and so on. In case of this, the ECU outputs are handled as invalid-values. When the first monitor (Readiness Status) is completed after this, the ECM outputs the valid-values.

NOTE: "Test Limit Type & Component ID byte" output from the ECM is given in hexadecimal of "00" or "80". "00" means the maximum value and "80" means the minimum value.

ON-BOARD DIAGNOSTICS

The engine control module (ECM) monitors the input/output signals (some signals all the time and others under specified conditions) of the ECM. When a malfunction continues for a specified time or longer after the irregular signal is initially monitored, the ECM judges that a malfunction has occurred. After the ECM first detects a malfunction, a diagnostic trouble code is recorded when the engine is restarted and the same malfunction is re-detected. However, for items marked with a "*1", a diagnostic trouble code is recorded on the first detection of the malfunction. There are 137 diagnostic items. The diagnostic results can be read out with a scan tool. Since memorization of the diagnostic trouble codes is backed up directly by the battery, the diagnostic results are memorized even if the ignition key is turned off. The diagnostic trouble codes will, however, be erased when the battery terminal or the ECM connector is disconnected. In addition, the diagnostic trouble code can also be erased by turning the ignition switch to ON and sending the diagnostic trouble code erase signal from scan tool MB991958 to the ECM.

NOTE: If the sensor connector is disconnected with the ignition switch turned on, the diagnostic trouble code is memorized. In this case, send the diagnostic trouble code erase signal to the ECM in order to erase the diagnostic memory. The 137 diagnostic items are all indicated sequentially from the smallest code number. The ECM records the engine operating condition when the diagnostic trouble code is set. This data is called "Freeze-frame" data. This data can be read by using the scan tool, and can then be used in simulation tests for troubleshooting. Data items are as follows:

NOTE: If the ECM detects multiple malfunctions, the ECM stores the "Freeze-frame" data for only the first item that was detected. However, if the ECM detects a misfire or a fuel system malfunction, the ECM stores the data by giving priority to the misfire or fuel system malfunction, regardless of the order in which the malfunction was detected.

NOTE: As for Diagnostic trouble code P1603, "Freeze-frame" data is not memorized.

Freeze Frame Data for M.U.T.-III

ITEM NO.	M.U.T.-III SCAN TOOL DISPLAY	DATA ITEM	UNIT or STATE
1	Odometer	Odometer	km or mile
2	Ignition cycle (Warm up cycle)	Ignition cycle (Warm up cycle)	–
4	Accumulated minute	Accumulated minute*	min

*NOTE: *: Accumulated time of current malfunction from time point when malfunction is detected.*

Freeze Frame Data (OBD) for M.U.T.-III

ITEM NO.	M.U.T.-III SCAN TOOL DISPLAY	DATA ITEM	UNIT or STATE
AA	Airflow sensor	Mass airflow sensor	g/s
AB	TP sensor (main)	Throttle position sensor (main)	%
BB	Barometric pressure sensor	Barometric pressure sensor	kPa or in.Hg
BC	Relative TP sensor	Relative throttle position sensor	%
BD	TP sensor (sub)	Throttle position sensor (sub)	%
BE	APP sensor (main)	Accelerator pedal position sensor (main)	%
BF	APP sensor (sub)	Accelerator pedal position sensor (sub)	%
C0	Fuel system status (bank 1)	Fuel control system status	• Open loop
			• Closed loop
			• Open loop-drive condition
			• Open loop-DTC set
			• Closed loop-O2 (rear) failed
C1*	Fuel system status (bank 2)	Fuel control system status (bank 2)	N/A
C2	Calculated load value	Calculated load value	%
C3	ECT sensor	Engine coolant temperature sensor	° C or ° F
C4	Short term fuel trim (bank 1)	Short term fuel trim	%
C5*	Short term fuel trim (bank 3)	Short term fuel trim (bank 3)	****
C6	Long term fuel trim (bank 1)	Long term fuel trim	%
C7*	Long term fuel trim (bank 3)	Long term fuel trim (bank 3)	****
CC	MAP sensor	Manifold absolute pressure sensor	kPa or in.Hg
CD	Crankshaft position sensor	Crankshaft position sensor	r/min
CE	Vehicle speed	Vehicle speed	km/h or mph
CF	Spark advance	Spark advance	° CA
D0	Intake air temperature sensor 1	Intake air temperature sensor 1	° C or ° F
D1	Time since engine running	Time since engine running	sec
D6	EVAP. emission purge SOL. duty	Evaporative emission purge solenoid duty	%
D7	Fuel level gauge	Fuel level gauge	%
D8	Power supply voltage	Power supply voltage	V
D9	Absolute load value	Absolute load value	%

ITEM NO.	M.U.T.-III SCAN TOOL DISPLAY	DATA ITEM	UNIT or STATE
DA	Target equivalence ratio	Target equivalence ratio	–
DB	Intake air temperature sensor 1	Intake air temperature sensor 1 (ambient air temperature)	° C or ° F
DC	Throttle actuator	Throttle actuator control motor	%
DD	Relative APP sensor	Relative accelerator pedal position sensor	%
DE	Intake air temperature sensor 2	Intake air temperature sensor 2	° C or ° F
242	Fuel tank differential PRS.SNSR	Fuel tank differential pressure sensor	Pa

*NOTE: *: Data items are displayed on M.U.T.-III display, but the in-line 4 engine is not applicable and its data is displayed as "N/A" or "*****".*

Freeze Frame Data for General Scan Tool

COMMON EXAMPLE of GENERAL SCAN TOOL DISPLAY	PRAMETER IDENTIFICATION (PID)	DESCRIPTION	UNIT or STATE
DTCFRZF	02	DTC that caused required freeze frame data storage	Pxxxx, Uxxxx
FUELSYS 1	03	See M.U.T.-III Item No. C0	
LOAD_PCT	04	See M.U.T.-III Item No. C2	
ECT	05	See M.U.T.-III Item No. C3	
SHRTFT 1	06	See M.U.T.-III Item No. C4	
LONGFT 1	07	See M.U.T.-III Item No. C6	
MAP	0B	See M.U.T.-III Item No. CC	
RPM	0C	See M.U.T.-III Item No. CD	
VSS	0D	See M.U.T.-III Item No. CE	
SPARKADV	0E	See M.U.T.-III Item No. CF	
IAT	0F	See M.U.T.-III Item No. D0	
MAF	10	See M.U.T.-III Item No. AA	
TP	11	See M.U.T.-III Item No. AB	
RUNTM	1F	See M.U.T.-III Item No. D1	
EVAP_PCT	2E	See M.U.T.-III Item No. D6	
FLI	2F	See M.U.T.-III Item No. D7	
EVAP_VP	32	See M.U.T.-III Item No. 242	
BARO	33	See M.U.T.-III Item No. BB	
VPWR	42	See M.U.T.-III Item No. D8	
LOAD_ABS	43	See M.U.T.-III Item No. D9	
EQ_RAT	44	See M.U.T.-III Item No. DA	
TP_R	45	See M.U.T.-III Item No. BC	
AAT	46	See M.U.T.-III Item No. DB	
TP_B	47	See M.U.T.-III Item No. BD	
APP_D	49	See M.U.T.-III Item No. BE	
APP_E	4A	See M.U.T.-III Item No. BF	
TAC_PCT	4C	Command Throttle Actuator Control	%
APP_R	5A	See M.U.T.-III Item No. DD	
IAT2	68	See M.U.T.-III Item No. DE	

OBD- II DRIVE CYCLE

All kinds of diagnostic trouble codes (DTCs) can be monitored by carrying out a short drive according to the following 23 drive cycle patterns. In other words, doing such a drive regenerates any kind of trouble which involves illuminating the Malfunction Indicator Lamp (SERVICE ENGINE SOON or Check Engine Lamp) and verifies the repair procedure has been eliminated [the trouble the Malfunction Indicator Lamp (SERVICE ENGINE SOON or Check Engine Lamp) is no longer illuminated].

⚠ CAUTION

Two technicians should always be in the vehicle when carrying out a test.

NOTE: Check that the diagnosis trouble code (DTC) is not output before driving the OBD-II drive cycle. Erase the DTC if it has been output.

NOTE: Drive cycle patterns are not established for Vehicle speed signal monitor (DTC P0500), Power steering pressure switch monitor (P0551), and Fuel level sensor monitor (DTC P0461, P2066). Please reference the M.U.T. data list to judge whether these monitor items are normal.

DRIVE CYCLE PATTERN LIST

MONITOR ITEM	DIAGNOSTIC TROUBLE CODE (DTC)	PATTERN
Heated oxygen sensor (front) monitor <Readiness test item>	P0133	1
Heated oxygen sensor (rear) feedback control system monitor	P2096, P2097	
Heated oxygen sensor heater monitor <Readiness test item>	P0031, P0037	2
Heated oxygen sensor heater monitor	P0032, P0038	
Catalytic converter monitor <Readiness test item>	P0420	3
Evaporative emission system leak monitor (small leak and gross leak) <Readiness test item>	P0442, P0455	4
Evaporative purge system monitor	P0441	
Fuel tank pressure sensor monitor	P0450	
Evaporative emission system leak monitor (very small leak) <Readiness test item>	P0456	5
Airflow sensor monitor	P0101	6
Manifold absolute pressure (MAP) sensor monitor	P0106, P0107	
Intake air temperature sensor monitor	P0096, P0111	7
Engine coolant temperature sensor monitor	P0116, P0125	8
Thermostat monitor	P0128	9
Heated oxygen sensor (rear) monitor <Readiness test item>	P0139	10
Air fuel ratio feedback monitor	P0134	11
Heated oxygen sensor (rear) monitor <Readiness test item>	P0140	12
Fuel tank temperature sensor monitor	P0181	13
Misfire monitor	P0300, P0301, P0302, P0303, P0304	14
Fuel tank pressure sensor monitor	P0451	15

MONITOR ITEM	DIAGNOSTIC TROUBLE CODE (DTC)	PATTERN
Power steering pressure switch monitor	P0554	16
Throttle position sensor plausibility monitor	P1233, P1234	
Mass airflow sensor plausibility monitor	P1235, P1238	
Torque monitor	P1241	
Wastegate system monitor	P0234	17
Idle speed control system monitor	P0506, P0507	18
Ignition timing retard control (cold start strategy) monitor	P050B	19
Idle speed control system monitor	P1506, P1507	
Variable valve timing system (MIVEC) monitor	P0010, P0011, P0013, P0014, P0016, P0017	20
Fuel trim monitor	P0171, P0172	21
Heated oxygen sensor monitor	P0131, P0137, P2195	22
Intake air temperature sensor monitor	P0097, P0098, P0112, P0113	23
Airflow sensor monitor	P0102, P0103	
Manifold absolute pressure (MAP) sensor monitor	P0108	
Engine coolant temperature sensor monitor	P0117, P0118	
Heated oxygen sensor monitor	P0132, P0138, P2252, P2253	
Fuel tank temperature sensor monitor	P0182, P0183	
Injector monitor	P0201, P0202, P0203, P0204	
Turbocharger wastgate solenoid monitor	P0243, P0247	
Knock sensor monitor	P0327, P0328	
Crankshaft position sensor monitor	P0335	
Camshaft position sensor monitor	P0340, P0365	
Evaporative emission purge solenoid monitor	P0443	
Evaporative emission ventilation solenoid monitor	P0446	
Fuel tank pressure sensor monitor	P0452, P0453	
Fuel level sensor monitor	P0462, P0463	
Engine RPM plausibility monitor	P1239	
Barometric pressure sensor monitor	P2228, P2229	

PATTERN 1

<p>Drive cycle pattern</p>	
<p>Inspection conditions</p>	<ul style="list-style-type: none"> • Engine coolant temperature: More than 76° C (169° F) • Condition of TC-SST: Shift lever "D" range
<p>Test procedure</p>	<ol style="list-style-type: none"> 1. Start the engine with all the accessories switched OFF. 2. Drive the vehicle for 6 minutes at the following conditions. (During the monitor) <p><i>NOTE: When the system is normal, the monitor is completed earlier.</i></p> <ul style="list-style-type: none"> • Vehicle speed: More than 30 km/h (19 mph) • Engine speed: More than 1,500 r/min, less than 3,500 r/min • Engine load: More than 20 %, less than 60 % • Without rapid accelerator pedal movement 3. Stop the vehicle in a safe place and turn the ignition switch to "LOCK" (OFF) position. 4. Start the engine and do Steps 1 to 3 again. <p><i>NOTE: When the vehicle is operating normally and the OBD-II Drive Cycle is carried out, the Readiness Codes will be set as "Complete" on the first drive cycle. The second drive cycle is required to set the Readiness Codes as "Complete" if a fault is detected during the first drive cycle.</i></p> 5. Confirm that the diagnostic trouble code (DTC) is not output.

PATTERN 2

<p>Test procedure</p>	<ol style="list-style-type: none"> 1. Start the engine with all the accessories switched OFF. 2. Let the engine idle for 10 seconds. (During the monitor) 3. Turn the ignition switch to the "LOCK" (OFF) position. 4. Start the engine and do Steps 1 to 3 again. <p><i>NOTE: When the vehicle is operating normally and the OBD-II Drive Cycle is carried out, the Readiness Codes will be set as "Complete" on the first drive cycle. The second drive cycle is required to set the Readiness Codes as "Complete" if a fault is detected during the first drive cycle.</i></p> 5. Confirm that the diagnostic trouble code (DTC) is not output.
-----------------------	--

PATTERN 3

<p>Drive cycle pattern</p>	<p>AK402432AD</p>
<p>Inspection conditions</p>	<ul style="list-style-type: none"> • Engine coolant temperature: More than 7° C (45° F) • Intake air temperature: More than -10° C (14° F) • Barometric pressure: More than 76 kPa (22.4 in.Hg) • Condition of TC-SST: Shift lever "D" range
<p>Test procedure</p>	<ol style="list-style-type: none"> 1. Start the engine with all accessories switched OFF. 2. Drive the vehicle for 5 minutes at the following conditions. (During the monitor) <ul style="list-style-type: none"> • Engine speed: Less than 3,500 r/min • Airflow rate: More than 13 g/sec, less than 45 g/sec • Accelerator pedal: Except full close • Without rapid accelerator pedal movement 3. Release the accelerator pedal for 5 seconds. 4. Drive the vehicle for 3 minutes at the following conditions. (During the monitor) <ul style="list-style-type: none"> • Engine speed: Less than 3,500 r/min • Airflow rate: More than 13 g/sec, less than 45 g/sec • Accelerator pedal: Except full close • Without rapid accelerator pedal movement <p><i>NOTE: When the system is normal, the monitor is completed earlier.</i></p> 5. Stop the vehicle in a safe place and turn the ignition switch to "LOCK" (OFF) position. 6. Start the engine and do Steps 1 to 5 again. <p><i>NOTE: When the vehicle is operating normally and the OBD-II Drive Cycle is carried out, the Readiness Codes will be set as "Complete" on the first drive cycle. The second drive cycle is required to set the Readiness Codes as "Complete" if a fault is detected during the first drive cycle.</i></p> 7. Confirm that the diagnostic trouble code (DTC) is not output.

PATTERN 4

<p>Drive cycle pattern</p>	<p style="text-align: right;">AK402430 AI</p>
<p>Inspection conditions</p>	<ul style="list-style-type: none"> • Engine coolant temperature at engine start: Less than 36° C (96° F) • Intake air temperature at engine start: Less than 36° C (96° F) • Fuel amount at engine start: More than 15 %, less than 40 % • Engine coolant temperature: More than 60° C (140° F) • Intake air temperature: More than 5° C (41° F), less than 45° C (113° F) • Barometric pressure: More than 76 kPa (22.4 in.Hg) • Fuel temperature: Less than 36° C (96° F) • Condition of TC-SST: Shift lever "D" range
<p>Test procedure</p>	<ol style="list-style-type: none"> 1. Start the engine with all the accessories switched OFF. 2. Drive the vehicle for 16 minutes at the following conditions. (During the monitor) <ul style="list-style-type: none"> • Engine speed: More than 1,600 r/min, less than 4,000 r/min • Vehicle speed: More than 20 km/h (12 mph) • Engine load: More than 20 %, less than 50 % • Without rapid accelerator pedal movement <p><i>NOTE: Keep running as long as possible with the power steering pressure switch in the OFF position.</i></p> <p><i>NOTE: When the system is normal, the monitor is completed earlier.</i></p> 3. Stop the vehicle in a safe place and turn the ignition switch to "LOCK" (OFF) position. 4. Start the engine and do Steps 1 to 3 again. <p><i>NOTE: When the vehicle is operating normally and the OBD-II Drive Cycle is carried out, the Readiness Codes will be set as "Complete" on the first drive cycle. The second drive cycle is required to set the Readiness Codes as "Complete" if a fault is detected during the first drive cycle.</i></p> 5. Confirm that the diagnostic trouble code (DTC) is not output.

PATTERN 5

Inspection conditions	<ul style="list-style-type: none"> • Engine coolant temperature at engine start: Less than 36° C (96° F) • Intake air temperature at engine start: Less than 36° C (96° F) • Fuel amount at engine start: More than 40 %, less than 85 % • Engine coolant temperature: More than 20° C (68° F) • Intake air temperature: More than -10° C (14° F) • Barometric pressure: More than 76 kPa (22.4 in.Hg) • Fuel temperature: Less than 33° C (91° F)
Test procedure	<ol style="list-style-type: none"> 1. Start the engine with all the accessories switched OFF. 2. Let the engine idle for 16 minutes. (During the monitor) <i>NOTE: When the system is normal, the monitor is completed earlier.</i> 3. Turn the ignition switch to "LOCK" (OFF) position. 4. Start the engine and do Steps 1 to 3 again. <i>NOTE: When the vehicle is operating normally and the OBD-II Drive Cycle is carried out, the Readiness Codes will be set as "Complete" on the first drive cycle. The second drive cycle is required to set the Readiness Codes as "Complete" if a fault is detected during the first drive cycle.</i> 5. Confirm that the diagnostic trouble code (DTC) is not output.

PATTERN 6

Drive cycle pattern	<p style="text-align: right;">AK402442AE</p>
Inspection conditions	<ul style="list-style-type: none"> • Engine coolant temperature at engine start: More than 0° C (32° F) • Condition of TC-SST: Shift lever "D" range
Test procedure	<ol style="list-style-type: none"> 1. Start the engine with all the accessories switched OFF. 2. Let the engine idle for 30 seconds. (During the monitor) 3. Accelerate the vehicle for 2 seconds at the following conditions. (During the monitor) <ul style="list-style-type: none"> • Engine speed: More than 1,500 r/min • Engine load: More than 20 % • Throttle position sensor output voltage: More than 3.5 volts 4. Stop the vehicle in a safe place and turn the ignition switch to "LOCK" (OFF) position. 5. Start the engine and do Steps 1 to 4 again. 6. Confirm that the diagnostic trouble code (DTC) is not output.

PATTERN 7

<p>Drive cycle pattern</p>	<p style="text-align: right;">AK402435AC</p>
<p>Inspection conditions</p>	<ul style="list-style-type: none"> • Engine coolant temperature: More than 76° C (169° F) • Condition of TC-SST: Shift lever "D" range
<p>Test procedure</p>	<ol style="list-style-type: none"> 1. Start the engine with all the accessories switched OFF. 2. Drive the vehicle at more than 50 km/h (31 mph) for 1 minute. 3. Stop the vehicle in a safe place and let the engine idle for 30 seconds. 4. Repeat Steps 2 and 3 again. 5. Stop the vehicle in a safe place and turn the ignition switch to "LOCK" (OFF) position. 6. Confirm that the diagnostic trouble code (DTC) is not output.

PATTERN 8

<p>Drive cycle pattern</p>	<p style="text-align: right;">AK900473 AB</p>
<p>Inspection conditions</p>	<ul style="list-style-type: none"> • Engine coolant temperature at engine start: More than 7° C (47° F) • Intake air temperature: Less than 60° C (140° F) • Engine coolant temperature: More than 40° C (104° F) • Condition of TC-SST: Shift lever "D" range
<p>Test procedure</p>	<ol style="list-style-type: none"> 1. Start the engine with all the accessories switched OFF. 2. Drive the vehicle for 5 minutes at the following condition. <ul style="list-style-type: none"> • Vehicle speed: More than 50 km/h (31 mph) • Air flow rate: More than 12 g/sec • Except fuel cut 3. Stop the vehicle in a safe place and let the engine idle for 30 seconds. 4. Turn the ignition switch to "LOCK" (OFF) position. 5. Confirm that the diagnostic trouble code (DTC) is not output.

PATTERN 9

<p>Drive cycle pattern</p>	
<p>Inspection conditions</p>	<ul style="list-style-type: none"> • Engine coolant temperature at engine start: More than -10°C (14°F), less than 60°C (140°F) • Intake air temperature: More than -10°C (14°F) • Dropping of intake air temperature since engine start: Less than 10°C (18°F) • Condition of TC-SST: Shift lever "D" range
<p>Test procedure</p>	<ol style="list-style-type: none"> 1. Start the engine with all the accessories switched OFF. 2. Drive the vehicle for 6 minutes at the following conditions. (During the monitor) <ul style="list-style-type: none"> • Vehicle speed: More than 50 km/h (31 mph) • Air flow rate: More than 10 g/sec <p><i>NOTE: The system is normal if engine coolant temperature will rise more than 77°C (171°F) within 6 minutes.</i></p> 3. Stop the vehicle in a safe place and turn the ignition switch to "LOCK" (OFF) position. 4. Start the engine and do Steps 1 to 3 again. 5. Confirm that the diagnostic trouble code (DTC) is not output.

PATTERN 10

<p>Drive cycle pattern</p>	
<p>Inspection conditions</p>	<ul style="list-style-type: none"> • Engine coolant temperature: More than 76° C (169° F) • Barometric pressure: More than 76 kPa (22.4 in.Hg) • Condition of TC-SST: Shift lever "D" range
<p>Test procedure</p>	<ol style="list-style-type: none"> 1. Start the engine with all the accessories switched OFF. 2. Drive the vehicle at 50 km/h (31 mph) for 6 minutes. 3. Release the accelerator pedal for 10 seconds then stop the vehicle in a safe place. (During the monitor) 4. Turn the ignition switch to "LOCK" (OFF) position. 5. Start the engine and do Steps 1 to 4 again. <p><i>NOTE: When the vehicle is operating normally and the OBD-II Drive Cycle is carried out, the Readiness Codes will be set as "Complete" on the first drive cycle. The second drive cycle is required to set the Readiness Codes as "Complete" if a fault is detected during the first drive cycle.</i></p> <ol style="list-style-type: none"> 6. Confirm that the diagnostic trouble code (DTC) is not output.

PATTERN 11

<p>Drive cycle pattern</p>	<p style="text-align: right;">AK402436AD</p>
<p>Inspection conditions</p>	<ul style="list-style-type: none"> • Engine coolant temperature: More than 7° C (45° F) • Condition of TC-SST: Shift lever "D" range
<p>Test procedure</p>	<ol style="list-style-type: none"> 1. Start the engine with all the accessories switched OFF. 2. Let the engine idle for 6 minutes. 3. Drive the vehicle for 30 seconds at the following conditions. (During the monitor) <ul style="list-style-type: none"> • Engine speed: More than 1,200 r/min • Engine load: More than 30 % • Throttle position sensor output: Less than 3.3 volts • Except fuel cut 4. Stop the vehicle in a safe place and turn the ignition switch to "LOCK" (OFF) position. 5. Confirm that the diagnostic trouble code (DTC) is not output.

PATTERN 12

<p>Drive cycle pattern</p>	
<p>Inspection conditions</p>	<ul style="list-style-type: none"> • Engine coolant temperature: More than 76° C (169° F) • Condition of TC-SST: Shift lever "D" range
<p>Test procedure</p>	<ol style="list-style-type: none"> 1. Start the engine with all the accessories switched OFF. 2. Drive the vehicle at 50 km/h (31 mph) for 5 minutes. 3. Release the accelerator pedal for 5 seconds then stop the vehicle in a safe place. 4. Increase the speed of the vehicle to 50 km/h (31 mph) under the following conditions, and then drive the vehicle for 1 minute. <ul style="list-style-type: none"> • Engine speed: More than 1,500 r/min • Engine load: More than 40 % 5. Release the accelerator pedal for 5 seconds then stop the vehicle in a safe place. 6. Repeat Steps 4 and 5 for 2 times. 7. Stop the vehicle in a safe place and turn the ignition switch to "LOCK" (OFF) position. 8. Start the engine and do Steps 1 to 7 again. <p><i>NOTE: When the vehicle is operating normally and the OBD-II Drive Cycle is carried out, the Readiness Codes will be set as "Complete" on the first drive cycle. The second drive cycle is required to set the Readiness Codes as "Complete" if a fault is detected during the first drive cycle.</i></p> <ol style="list-style-type: none"> 9. Confirm that the diagnostic trouble code (DTC) is not output.

PATTERN 13

<p>Inspection conditions</p>	<ul style="list-style-type: none"> • Engine coolant temperature at engine start: More than -10° C (14° F), less than 36° C (97° F) • Difference between engine coolant temperature and intake air temperature at engine start: Less than 5° C (9° F) • Condition of TC-SST: Shift lever "D" range
<p>Test procedure</p>	<ol style="list-style-type: none"> 1. Start the engine with all the accessories switched OFF. 2. Drive the vehicle at more than 30 km/h (19 mph) until engine coolant temperature rises more than 60° C (140° F). (During the monitor) 3. Stop the vehicle in a safe place and turn the ignition switch to "LOCK" (OFF) position. 4. Start the engine and do Steps 1 to 3 again. 5. Confirm that the diagnostic trouble code (DTC) is not output.

PATTERN 14

<p>Drive cycle pattern</p>	<p>AK402440AE</p>
<p>Inspection conditions</p>	<ul style="list-style-type: none"> • Engine coolant temperature: More than -10°C (14°F) • Barometric pressure: More than 76 kPa (22.4 in.Hg) • Condition of TC-SST: Shift lever "D" range
<p>Test procedure</p>	<ol style="list-style-type: none"> 1. Start the engine with all the accessories switched OFF. 2. Drive the vehicle for 3 minutes at the following conditions. (During the monitor) <ul style="list-style-type: none"> • Engine speed: More than 500 r/min, less than 3,000 r/min • Engine load: More than 25 % • Without rapid accelerator pedal change • Except fuel cut 3. Stop the vehicle in a safe place and turn the ignition switch to "LOCK" (OFF) position. 4. Start the engine and do Steps 1 to 3 again. 5. Confirm that the diagnostic trouble code (DTC) is not output.

PATTERN 15

<p>Drive cycle pattern</p>	<p>Vehicle speed</p> <p>50 km/h (31 mph)</p> <p>Idling</p> <p>Ignition switch: "LOCK" (OFF)</p> <p>1st monitor</p> <p>2nd monitor</p> <p>9th monitor</p> <p>10th monitor</p> <p>20 seconds</p> <p>20 seconds</p> <p>Time</p> <p>AK402438AC</p>
<p>Inspection condition</p>	<p>Condition of TC-SST: Shift lever "D" range</p>
<p>Test procedure</p>	<ol style="list-style-type: none"> 1. Start the engine with all the accessories switched OFF. 2. Accelerate until the vehicle speed is more than 50 km/h (31 mph). 3. Stop the vehicle in a safe place and let the engine idle for 20 seconds. (During the monitor) 4. Repeat Steps 2 and 3 for 10 times. 5. Stop the vehicle in a safe place and turn the ignition switch to "LOCK" (OFF) position. 6. Start the engine and do Steps 1 to 5 again. 7. Confirm that the diagnostic trouble code (DTC) is not output.

PATTERN 16

<p>Drive cycle pattern</p>	<p>Vehicle speed</p> <p>50 km/h (31 mph)</p> <p>During the monitor</p> <p>Ignition switch: "LOCK" (OFF)</p> <p>30 seconds</p> <p>Time</p> <p>AK402441AP</p>
<p>Inspection conditions</p>	<ul style="list-style-type: none"> • Engine coolant temperature: More than 65° C (149° F) • Condition of TC-SST: Shift lever "D" range
<p>Test procedure</p>	<ol style="list-style-type: none"> 1. Start the engine with all the accessories switched OFF. 2. Drive the vehicle at more than 50 km/h (31 mph) for 30 seconds. (During the monitor) 3. Stop the vehicle in a safe place and turn the ignition switch to "LOCK" (OFF) position. 4. Start the engine and do Steps 1 to 3 again. 5. Confirm that the diagnostic trouble code (DTC) is not output.

PATTERN 17

Inspection conditions	Condition of TC-SST: Shift lever "D" range
Test procedure	<ol style="list-style-type: none"> 1. Start the engine with all the accessories switched OFF. 2. Drive the vehicle with the accelerator pedal fully depressed for 5 seconds. (During the monitor) 3. Stop at safe place and turn the ignition switch to "LOCK" (OFF) position. 4. Start the engine and do Steps 1 to 3 again. 5. Confirm that the diagnostic trouble code (DTC) is not output.

PATTERN 18

Inspection conditions	<ul style="list-style-type: none"> • Engine coolant temperature: More than 41° C (106° F) • Intake air temperature: More than -10° C (14° F) • Barometric pressure: More than 76 kPa (22.4 in.Hg)
Test procedure	<ol style="list-style-type: none"> 1. Start the engine with all the accessories switched OFF. 2. Let the engine idle for 1 minute. (During the monitor) 3. Turn the ignition switch to "LOCK" (OFF) position. 4. Start the engine and do Steps 1 to 3 again. 5. Confirm that the diagnostic trouble code (DTC) is not output.

PATTERN 19

Inspection conditions	<ul style="list-style-type: none"> • Engine coolant temperature: More than 7° C (45° F), less than 36° C (97° F) • Intake air temperature: More than -10° C (14° F) • Barometric pressure: More than 76 kPa (22.4 in.Hg)
Test procedure	<ol style="list-style-type: none"> 1. Start the engine with all the accessories switched OFF. 2. Let the engine idle for 1 minute. (During the monitor) 3. Turn the ignition switch to "LOCK" (OFF) position. 4. Start the engine and do Steps 1 to 3 again. 5. Confirm that the diagnostic trouble code (DTC) is not output.

PATTERN 20

Inspection condition	Engine coolant temperature: More than 77° C (171° F), less than 87° C (189° F)
Test procedure	<ol style="list-style-type: none"> 1. Start the engine with all the accessories switched OFF. 2. Drive the engine at 1,200 –1,500 r/min for 30 seconds. (During the monitor) 3. Turn the ignition switch to "LOCK" (OFF) position. 4. Start the engine and do Steps 1 to 3 again. 5. Confirm that the diagnostic trouble code (DTC) is not output.

PATTERN 21

Inspection condition	Engine coolant temperature: More than 76° C (169° F)
Test procedure	<ol style="list-style-type: none"> 1. Start the engine with all the accessories switched OFF. 2. Let the engine idle for 15 minutes. (During the monitor) 3. Turn the ignition switch to "LOCK" (OFF) position. 4. Start the engine and do Steps 1 to 3 again. 5. Confirm that the diagnostic trouble code (DTC) is not output.

PATTERN 22

Inspection conditions	<ul style="list-style-type: none"> • Intake air temperature: More than -10° C (14° F) • Engine coolant temperature: More than 7° C (45° F)
Test procedure	<ol style="list-style-type: none"> 1. Start the engine with all the accessories switched OFF. 2. Let the engine idle for 8 minutes. (During the monitor) 3. Turn the ignition switch to "LOCK" (OFF) position. 4. Start the engine and do Steps 1 to 3 again. 5. Confirm that the diagnostic trouble code (DTC) is not output.

PATTERN 23

Inspection conditions	<ul style="list-style-type: none"> • Engine coolant temperature: More than 0° C (32° F) <Manifold absolute pressure sensor monitor> • Fuel temperature: Less than 36° C (96° F) <Fuel tank pressure sensor monitor> • Fuel amount at engine start: Less than 85 % <Fuel tank pressure sensor monitor>
Test procedure	<ol style="list-style-type: none"> 1. Start the engine with all the accessories switched OFF. 2. Let the engine idle at the engine speed less than 1,000 r/min for 15 seconds. (During the monitor) 3. Turn the ignition switch to "LOCK" (OFF) position. 4. Start the engine and do Steps 1 to 3 again. 5. Confirm that the diagnostic trouble code (DTC) is not output.

SYSTEM READINESS TEST STATUS

PURPOSE

The Readiness function (also referred to as I/M Readiness or I/M Flags) indicates if a full diagnostic check has been "Completed" (is "Ready") for each non-continuous monitor. Enhanced I/M State Emission Programs will use the Readiness status (Codes) to see if the vehicle is ready for OBD-II testing. "Incomplete" (Not Ready) codes will be one of the triggers for I/M failure.

OVERVIEW

The ECM monitors the following main diagnosis items and records whether the evaluation was completed or is incomplete. The Readiness Codes are established for the I/M programs, thereby confirming that the vehicles have not been tampered with by erasing the diagnostic trouble code(s) (DTCs) before I/M testing. The Readiness Codes and DTCs can be reset by disconnecting the battery or by erasing the codes with a scan tool MB991958 (M.U.T.-III sub assembly). For this reason, all the Readiness Codes must be displayed "Complete" before I/M testing.

When the monitors run and complete, the scan tool MB991958 (M.U.T.-III sub assembly) will display the Readiness Codes as "Complete" (General Scan Tools display as "Ready"). When the vehicle is operating normally and the OBD-II Drive Cycle is carried out, the Readiness Codes will be set as "Complete" on the first drive cycle. For DTCs requiring two drive cycles to detect a fault, the second drive cycle is required to set the Readiness Codes as "Complete" if a fault is detected during the first drive cycle. If the fault is still there after the second drive cycle, a DTC will be set.

- Catalyst: P0420
- Evaporative system: P0442, P0455, P0456
- Heated oxygen sensor: P0133, P0139, P0140
- Heated oxygen sensor heater: P0031, P0037

After all the Readiness Codes are displayed as "Complete", the technician is assured that any DTCs related to the monitor will be displayed if the system has a problem. That is why some State's I/M programs require the Readiness Code as "Complete" before they check for DTCs.

NOTE: After a repair is made for a DTC, the technician should drive the OBD-II Drive Cycle checking that the scan tool MB991958 (M.U.T.-III Sub Assembly) displays all the Readiness Codes as "Complete".

FAIL-SAFE FUNCTION REFERENCE TABLE

The control is carried out, which keeps the safety driving by the preset control logic when the diagnostic trouble code is output. The diagnostic trouble code having the fail-safe function is as follows.

DTC	DIAGNOSTIC ITEM	FAIL-SAFE AND BACKUP FUNCTION
P0010	Intake engine oil control valve circuit	V.V.T.phase angle (intake) becomes most retarded angle.
P0013	Exhaust engine oil control valve circuit	V.V.T.phase angle (exhaust) becomes most advanced angle.
P0096	Intake air temperature circuit range/performance problem (sensor 2)	Control as if the intake air temperature in the intake manifold is 25° C.
P0097	Intake air temperature circuit low input (sensor 2)	Control as if the intake air temperature in the intake manifold is 25° C.
P0098	Intake air temperature circuit high input (sensor 2)	Control as if the intake air temperature in the intake manifold is 25° C.
P0111	Intake air temperature circuit range/performance problem (sensor 1)	Control as if the intake air temperature is 25° C.
P0112	Intake air temperature circuit low input (sensor 1)	Control as if the intake air temperature is 25° C.
P0113	Intake air temperature circuit high input (sensor 1)	Control as if the intake air temperature is 25° C.
P0116	Engine coolant temperature circuit range/performance problem	Control as if the engine coolant temperature is 80° C.
P0117	Engine coolant temperature circuit low input	Control as if the engine coolant temperature is 80° C.
P0118	Engine coolant temperature circuit high input	Control as if the engine coolant temperature is 80° C.
P0122	Throttle position sensor (main) circuit low input	<ul style="list-style-type: none"> • Throttle opening degree is restricted. • Throttle opening degree position is in default position if throttle position sensor (sub) fails.
P0123	Throttle position sensor (main) circuit high input	<ul style="list-style-type: none"> • Throttle opening degree is restricted. • Throttle opening degree position is in default position if throttle position sensor (sub) fails.
P0125	Insufficient coolant temperature for closed loop fuel control	Control as if the engine coolant temperature is 80° C.
P0222	Throttle position sensor (sub) circuit low input	<ul style="list-style-type: none"> • Throttle opening degree is restricted. • Throttle opening degree position is in default position if throttle position sensor (main) fails.
P0223	Throttle position sensor (sub) circuit high input	<ul style="list-style-type: none"> • Throttle opening degree is restricted. • Throttle opening degree position is in default position if throttle position sensor (main) fails.
P0234	Turbocharger wastegate system malfunction	Fuel is cut in abnormal engine overboost condition.

DTC	DIAGNOSTIC ITEM	FAIL-SAFE AND BACKUP FUNCTION
P0300	Random/multiple cylinder misfire detected	The supply of fuel to the misfiring cylinder can possibly be cut.
P0301	Cylinder 1 misfire detected	The supply of fuel to the misfiring cylinder can possibly be cut.
P0302	Cylinder 2 misfire detected	The supply of fuel to the misfiring cylinder can possibly be cut.
P0303	Cylinder 3 misfire detected	The supply of fuel to the misfiring cylinder can possibly be cut.
P0304	Cylinder 4 misfire detected	The supply of fuel to the misfiring cylinder can possibly be cut.
P0327	Knock sensor circuit low	Fix the ignition timing with an allowance against knock.
P0328	Knock sensor circuit high	Fix the ignition timing with an allowance against knock.
P0340	Intake camshaft position sensor circuit	<ul style="list-style-type: none"> • Engine runs in learned pattern until engine stops. • Does not control variable valve timing (V.V.T.).
P0365	Exhaust camshaft position sensor circuit	Does not control variable valve timing (V.V.T.).
P0513	Immobilizer malfunction	Engine start is prohibited.
P0606	Engine control module main processor malfunction	Throttle opening degree position is in default position.
P0622	Generator FR terminal circuit malfunction	Prohibits generator output suppression control against current consumers. (Operates as a normal generator.)
P0638	Throttle actuator control motor circuit range/performance	Throttle opening degree position is in default position.
P0642	Throttle position sensor power supply	Throttle opening degree position is in default position.
P0657	Throttle actuator control motor relay circuit malfunction	Throttle opening degree position is in default position.
P1231	Active stability control plausibility	Torque requested by active stability control (ASC) is ignored.
P1232	Fail safe system	Microcomputer is reset.
P1233	Throttle position sensor (main) plausibility	<ul style="list-style-type: none"> • Throttle opening degree is restricted. • Throttle opening degree position is in default position if throttle position sensor (sub) fails.
P1234	Throttle position sensor (sub) plausibility	<ul style="list-style-type: none"> • Throttle opening degree is restricted. • Throttle opening degree position is in default position if throttle position sensor (main) fails.
P1235	Mass airflow sensor plausibility	Fuel control is carried out using throttle opening degree and engine speed in accordance with preset map.

DTC	DIAGNOSTIC ITEM	FAIL-SAFE AND BACKUP FUNCTION
P1236	A/D converter	Throttle opening degree position is in default position.
P1237	Accelerator pedal position sensor plausibility	Throttle opening degree position is in default position.
P1238	Mass airflow sensor plausibility (torque monitor)	Throttle opening degree position is in default position.
P1239	Engine RPM plausibility	Throttle opening degree position is in default position.
P1240	Ignition angle	Ignition retard is not carried out.
P1241	Torque monitor	Throttle opening degree position is in default position.
P1242	Fail safe control monitor	Throttle opening degree position is in default position.
P1243	Inquiry/response error	Microcomputer is reset.
P1244	RAM test for all area	Microcomputer is reset.
P1245	Cycle RAM test (engine)	Microcomputer is reset.
P1247	TC-SST plausibility <TC-SST>	Torque requested by TC-SST-ECU is ignored.
P1590	TCM to ECM communication error in torque reduction request <TC-SST>	Engine output is restricted.
P1603	Battery backup circuit malfunction	All diagnosis codes are stored once failure judgment is completed.
P2100	Throttle actuator control motor circuit (open)	Throttle opening degree position is in default position.
P2101	Throttle actuator control motor magneto malfunction	Throttle opening degree position is in default position.
P2122	Accelerator pedal position sensor (main) circuit low input	<ul style="list-style-type: none"> • Throttle opening degree is restricted. • Throttle opening degree position is in default position if accelerator pedal position sensor (sub) fails.
P2123	Accelerator pedal position sensor (main) circuit high input	<ul style="list-style-type: none"> • Throttle opening degree is restricted. • Throttle opening degree position is in default position if accelerator pedal position sensor (sub) fails.
P2127	Accelerator pedal position sensor (sub) circuit low input	<ul style="list-style-type: none"> • Throttle opening degree is restricted. • Throttle opening degree position is in default position if accelerator pedal position sensor (main) fails.
P2128	Accelerator pedal position sensor (sub) circuit high input	<ul style="list-style-type: none"> • Throttle opening degree is restricted. • Throttle opening degree position is in default position if accelerator pedal position sensor (main) fails.
P2135	Throttle position sensor (main and sub) range/performance problem	Throttle opening degree position is in default position.

DTC	DIAGNOSTIC ITEM	FAIL-SAFE AND BACKUP FUNCTION
P2138	Accelerator pedal position sensor (main and sub) range/performance problem	<ul style="list-style-type: none"> • Throttle opening degree is restricted. • Throttle opening degree position is in default position if accelerator pedal position sensor (sub) fails.
P2228	Barometric pressure circuit low input	Control as if the barometric pressure is 101 kPa.
P2229	Barometric pressure circuit high input	Control as if the barometric pressure is 101 kPa.
P2253	Heated oxygen sensor offset circuit high voltage	Does not control air-fuel ratio closed loop.
P2263	Intake charge system malfunction	Fuel is cut in engine overboost condition.
U0167	Immobilizer communication error	Engine start is prohibited.

DIAGNOSTIC TROUBLE CODE CHART

⚠ CAUTION

During diagnosis, a DTC code associated with other system may be set when the ignition switch is turned on with connector(s) disconnected. On completion, confirm all systems for DTC(s). If DTC(s) are set, erase them all.

DTC	DIAGNOSTIC ITEM	REFERENCE PAGE
P0010	Intake engine oil control valve circuit	P.13A-56
P0011	Intake variable valve timing system target error	P.13A-62
P0012	Camshaft position - timing over-retarded	P.13A-66
P0013	Exhaust engine oil control valve circuit	P.13A-67
P0014	Exhaust variable valve timing system target error	P.13A-73
P0016	Crankshaft/camshaft (intake) position sensor phase problem	P.13A-76
P0017	Crankshaft/camshaft (exhaust) position sensor phase problem	P.13A-80
P0031	Heated oxygen sensor (front) heater circuit low	P.13A-84
P0032	Heated oxygen sensor (front) heater circuit high	P.13A-91
P0037	Heated oxygen sensor (rear) heater circuit low	P.13A-95
P0038	Heated oxygen sensor (rear) heater circuit high	P.13A-102
P0069	Abnormal correlation between manifold absolute pressure sensor and barometric pressure sensor	P.13A-106
P0096* ¹	Intake air temperature circuit range/performance problem (sensor 2)	P.13A-110
P0097* ¹	Intake air temperature circuit low input (sensor 2)	P.13A-117
P0098* ¹	Intake air temperature circuit high input (sensor 2)	P.13A-121
P0101* ¹	Mass airflow circuit range/performance problem	P.13A-127
P0102* ¹	Mass airflow circuit low input	P.13A-133
P0103* ¹	Mass airflow circuit high input	P.13A-140
P0106	Manifold absolute pressure circuit range/performance problem	P.13A-145
P0107	Manifold absolute pressure circuit low input	P.13A-154
P0108	Manifold absolute pressure circuit high input	P.13A-162
P0111* ¹	Intake air temperature circuit range/performance problem (sensor 1)	P.13A-167
P0112* ¹	Intake air temperature circuit low input (sensor 1)	P.13A-173
P0113* ¹	Intake air temperature circuit high input (sensor 1)	P.13A-177
P0116* ¹	Engine coolant temperature circuit range/performance problem	P.13A-183
P0117* ¹	Engine coolant temperature circuit low input	P.13A-189
P0118* ¹	Engine coolant temperature circuit high input	P.13A-194
P0122* ¹	Throttle position sensor (main) circuit low input	P.13A-201
P0123* ¹	Throttle position sensor (main) circuit high input	P.13A-205
P0125* ¹	Insufficient coolant temperature for closed loop fuel control	P.13A-212

DTC	DIAGNOSTIC ITEM	REFERENCE PAGE
P0128	Coolant thermostat (coolant temperature below thermostat regulating temperature)	P.13A-220
P0131	Heated oxygen sensor (front) circuit low voltage	P.13A-223
P0132	Heated oxygen sensor (front) circuit high voltage	P.13A-231
P0133	Heated oxygen sensor (front) circuit slow response	P.13A-235
P0134* ¹	Heated oxygen sensor (front) circuit no activity detected	P.13A-240
P0137	Heated oxygen sensor (rear) circuit low voltage	P.13A-246
P0138	Heated oxygen sensor (rear) circuit high voltage	P.13A-254
P0139	Heated oxygen sensor (rear) circuit slow response	P.13A-258
P0140	Heated oxygen sensor (rear) circuit no activity detected	P.13A-263
P0171	System too lean	P.13A-267
P0172	System too rich	P.13A-273
P0181	Fuel tank temperature sensor circuit range/performance	P.13A-279
P0182	Fuel tank temperature sensor circuit low input	P.13A-286
P0183	Fuel tank temperature sensor circuit high input	P.13A-291
P0201	Injector circuit-cylinder 1	P.13A-298
P0202	Injector circuit-cylinder 2	P.13A-308
P0203	Injector circuit-cylinder 3	P.13A-318
P0204	Injector circuit-cylinder 4	P.13A-328
P0219* ¹	Engine over speed condition	P.13A-338
P0222* ¹	Throttle position sensor (sub) circuit low input	P.13A-339
P0223* ¹	Throttle position sensor (sub) circuit high input	P.13A-345
P0234	Turbocharger wastegate system malfunction	P.13A-350
P0243	Turbocharger wastegate solenoid 1 circuit	P.13A-352
P0247	Turbocharger wastegate solenoid 2 circuit	P.13A-359
P0300* ²	Random/multiple cylinder misfire detected	P.13A-365
P0301* ²	Cylinder 1 misfire detected	P.13A-370
P0302* ²	Cylinder 2 misfire detected	P.13A-373
P0303* ²	Cylinder 3 misfire detected	P.13A-376
P0304* ²	Cylinder 4 misfire detected	P.13A-379
P0327	Knock sensor circuit low	P.13A-383
P0328	Knock sensor circuit high	P.13A-386
P0335* ¹	Crankshaft position sensor circuit	P.13A-389
P0340* ¹	Intake camshaft position sensor circuit	P.13A-399
P0365* ¹	Exhaust camshaft position sensor circuit	P.13A-407
P0420	Warm up catalyst efficiency below threshold	P.13A-416

DTC	DIAGNOSTIC ITEM	REFERENCE PAGE
P0441	Evaporative emission control system incorrect purge flow	P.13A-418
P0442	Evaporative emission control system leak detected (small leak)	P.13A-422
P0443	Evaporative emission control system purge control valve circuit	P.13A-434
P0446	Evaporative emission control system vent control circuit	P.13A-441
P0450	Evaporative emission control system pressure sensor malfunction	P.13A-448
P0451	Evaporative emission control system pressure sensor range/performance	P.13A-456
P0452	Evaporative emission control system pressure sensor low input	P.13A-465
P0453	Evaporative emission control system pressure sensor high input	P.13A-475
P0455	Evaporative emission control system leak detected (gross leak)	P.13A-483
P0456	Evaporative emission control system leak detected (very small leak)	P.13A-494
P0461	Fuel level sensor (main) circuit range/performance	P.13A-505
P0462	Fuel level sensor circuit low input	P.13A-508
P0463	Fuel level sensor circuit high input	P.13A-511
P0500* ¹	Vehicle speed signal malfunction	P.13A-513
P0506	Idle control system RPM lower than expected	P.13A-516
P0507	Idle control system RPM higher than expected	P.13A-519
P050B	Ignition timing retard insufficient	P.13A-522
P0513	Immobilizer malfunction	P.13A-525
P0551	Power steering pressure switch circuit range/performance	P.13A-527
P0554	Power steering pressure switch circuit intermittent	P.13A-534
P0603* ¹	EEPROM malfunction	P.13A-538
P0606* ¹	Engine control module main processor malfunction	P.13A-540
P0622	Generator FR terminal circuit malfunction	P.13A-546
P0630* ¹	Vehicle Identification Number (VIN) malfunction	P.13A-551
P0638* ¹	Throttle actuator control motor circuit range/performance	P.13A-553
P0642* ¹	Throttle position sensor power supply	P.13A-556
P0657* ¹	Throttle actuator control motor relay circuit malfunction	P.13A-558
P0830	Clutch pedal position switch circuit range/performance <M/T>	P.13A-566
P1231	Active stability control plausibility	P.13A-570
P1232	Fail safe system	P.13A-572
P1233* ¹	Throttle position sensor (main) plausibility	P.13A-573
P1234* ¹	Throttle position sensor (sub) plausibility	P.13A-577
P1235* ¹	Mass airflow sensor plausibility	P.13A-580
P1236* ¹	A/D converter	P.13A-583
P1237* ¹	Accelerator pedal position sensor plausibility	P.13A-584

DTC	DIAGNOSTIC ITEM	REFERENCE PAGE
P1238*1	Mass airflow sensor plausibility (torque monitor)	P.13A-587
P1239*1	Engine RPM plausibility	P.13A-590
P1240	Ignition angle	P.13A-593
P1241*1	Torque monitor	P.13A-594
P1242	Fail safe control monitor	P.13A-598
P1243	Inquiry/response error	P.13A-600
P1244	RAM test for all area	P.13A-601
P1245	Cycle RAM test (engine)	P.13A-602
P1247	TC-SST plausibility <TC-SST>	P.13A-603
P1506	Idle control system RPM lower than expected at low temperature	P.13A-604
P1507	Idle control system RPM higher than expected at low temperature	P.13A-607
P1590*1	TCM to ECM communication error in torque reduction request <TC-SST>	P.13A-610
P1603*1	Battery backup circuit malfunction	P.13A-613
P1676*1	Variant coding	P.13A-617
P2066	Fuel level sensor (sub) circuit range/performance	P.13A-619
P2096	Post catalyst fuel trim system too lean	P.13A-622
P2097	Post catalyst fuel trim system too rich	P.13A-625
P2100*1	Throttle actuator control motor circuit (open)	P.13A-629
P2101*1	Throttle actuator control motor magneto malfunction	P.13A-634
P2122*1	Accelerator pedal position sensor (main) circuit low input	P.13A-638
P2123*1	Accelerator pedal position sensor (main) circuit high input	P.13A-643
P2127*1	Accelerator pedal position sensor (sub) circuit low input	P.13A-648
P2128*1	Accelerator pedal position sensor (sub) circuit high input	P.13A-653
P2135*1	Throttle position sensor (main and sub) range/performance problem	P.13A-657
P2138*1	Accelerator pedal position sensor (main and sub) range/performance problem	P.13A-663
P2195	Heated oxygen sensor (front) inactive	P.13A-670
P2228*1	Barometric pressure circuit low input	P.13A-673
P2229*1	Barometric pressure circuit high input	P.13A-675
P2252	Heated oxygen sensor offset circuit low voltage	P.13A-677
P2253	Heated oxygen sensor offset circuit high voltage	P.13A-679
P2263	Intake charge system malfunction	P.13A-681
U0001	Bus off	P.13A-684
U0101*1	TC-SST-ECU time-out <TC-SST>	P.13A-685
U0121*1	ASC-ECU time-out	P.13A-689

DTC	DIAGNOSTIC ITEM	REFERENCE PAGE
U0141* ¹	ETACS-ECU time-out	P.13A-694
U0167	Immobilizer communication error	P.13A-698
U1180* ¹	Combination meter time-out	P.13A-700

NOTE: Do not replace the engine control module (ECM) until a through terminal check reveals there are no short/open circuits.

NOTE: Check that the ECM ground circuit is normal before checking for the cause of the problem.

*NOTE: After the ECM detects a malfunction, a diagnostic trouble code is recorded the next time the engine is started and the same malfunction is re-detected. However, for items marked with a "*1", the diagnostic trouble code is recorded on the first detection of the malfunction.*

*NOTE: The codes marked with a "*2" in the diagnostic trouble code number column have the following two conditions for recording the diagnostic trouble code.*

- In case that the misfire causing the damaged catalyst is detected, the diagnostic trouble code is recorded at the time.
- In case that the misfire deteriorating the exhaust gas is detected, the diagnostic trouble code is recorded when the same malfunction is re-detected after the next engine start.

NOTE: Sensor 1 of the heated oxygen sensor indicates the sensor mounted at a position closest to the engine, and sensor 2 of the heated oxygen sensor indicates the sensor mounted at the position second closest to the engine.

SYMPTOM CHART

M1131151503134

⚠ CAUTION

During diagnosis, a DTC associated with other systems may be set when the ignition switch is turned on with connector(s) disconnected. On completion, confirm all systems for DTC(s). If DTC(s) are set, erase them all.

⚠ CAUTION

Disconnecting the battery cables or removing the combination meter will erase the learned value of the fuel gauge. To recover the learned value, input a vehicle speed (by actually driving the vehicle or inputting a simulated vehicle speed), and stop the vehicle. This will complete the learning process.

NOTE: Check that the ECM ground circuit is normal before checking for the cause of the problem.

NOTE: When the racing (2,000 to 5,000 r/min or more) continues on the vehicle stopped with no load during the specified time or more, the increase in the engine speed might be limited. This comes from the engine protection and control functions and is not a malfunction.

TROUBLE SYMPTOMS		INSPECTION PROCEDURE	REFERENCE PAGE
Communication with scan tool is impossible	Communication with ECM only is not possible	1	P.13A-704
Malfunction Indicator Lamp (SERVICE ENGINE SOON or Check Engine Lamp) and related parts	The Malfunction Indicator Lamp (SERVICE ENGINE SOON or Check Engine Lamp) does not illuminate right after the ignition switch is turned to the "ON" position	2	P.13A-708
	The Malfunction Indicator Lamp (SERVICE ENGINE SOON or Check Engine Lamp) remains illuminated and never goes out	3	P.13A-709
Starting	Cranks, won't start	4	P.13A-711
	Starts up and dies	5	P.13A-718
	Hard starting	6	P.13A-722
Idling stability (improper idling)	Unstable idle (rough idle, hunting)	7	P.13A-727
	Idle speed is high (improper idle speed)	8	P.13A-730
	Idle speed is low (improper idle speed)	9	P.13A-732
Idling stability (engine stalls)	When the engine is cold, it stalls at idle (die out)	10	P.13A-733
	When the engine is hot, it stalls at idle (die out)	11	P.13A-735
	The engine stalls when accelerating (pass out)	12	P.13A-738
	The engine stalls when decelerating	13	P.13A-740
Driving	Hesitation, sag, Stumble, Poor acceleration or Surge	14	P.13A-742
	Acceleration shock	15	P.13A-745
	Knocking	16	P.13A-747
Too high CO and HC concentration when idling		17	P.13A-749

TROUBLE SYMPTOMS		INSPECTION PROCEDURE	REFERENCE PAGE
IM240 test failure	Transient, mass emission tailpipe test failure	18	P.13A-751
	Purge flow test of the evaporative emission canister failure	19	P.13A-755
	Pressure test of the evaporative system failure	20	P.13A-756
Generator output voltage is low (approximately 12.3 volts)		21	P.13A-757
Power supply system and ignition switch-IG system		22	P.13A-760
Fuel pump system		23	P.13A-771
Ignition switch-ST system and starter relay system <M/T>		24	P.13A-784
Ignition switch-ST system and starter relay system <TC-SST>		25	P.13A-796
Ignition circuit system		26	P.13A-808
A/C system		27	P.13A-813
Engine oil pressure switch system		28	P.13A-816

PROBLEM SYMPTOMS TABLE (FOR YOUR INFORMATION)

ITEMS		SYMPTOM
At starting	Won't start	The starter cranks the engine, but there is no combustion within the cylinders, and the engine won't start.
	Starts up and dies	The engine starts, but then engine soon stalls.
	Hard starting	Engine starts after cranking a while.
Idling stability	Hunting	Engine speed doesn't remain constant; changes at idle.
	Rough idle	Usually, a judgement can be based upon the movement of the tachometer pointer, and the vibration transmitted to the steering wheel, shift lever, body, etc.
	Incorrect idle speed	The engine doesn't idle at the correct speed.
	Engine stall (die out)	The engine stalls when the foot is taken from the accelerator pedal, regardless of whether the vehicle is moving or not.
	Engine stall (pass out)	The engine stalls when the accelerator pedal is depressed.

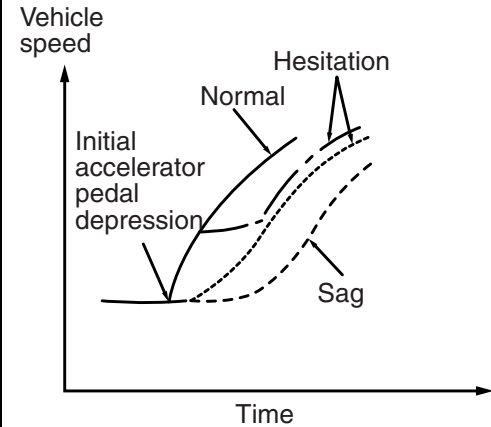
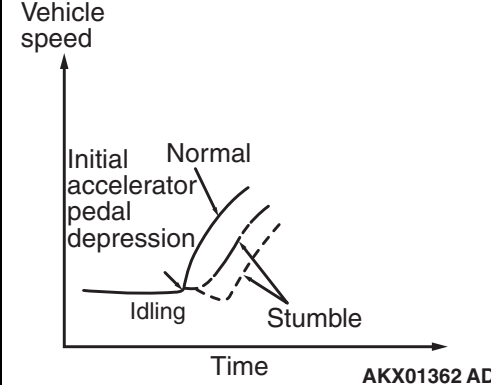
ITEMS	SYMPTOM	
At driving	Hesitation Sag	<p>"Hesitation" is the delay in response of the vehicle speed (engine speed). This occurs when the accelerator is depressed in order to accelerate from the speed at which the vehicle is now traveling, or a temporary drop in vehicle speed (engine speed) during such acceleration. Serious hesitation is called "sag".</p>  <p align="right">AKX01361AC</p>
	Poor acceleration	<p>Poor acceleration is inability to obtain an acceleration corresponding to the degree of throttle opening, even though acceleration is smooth. Also the inability to reach maximum speed.</p>
	Stumble	<p>Engine speed increase is delayed when the accelerator pedal is initially depressed for acceleration.</p>  <p align="right">AKX01362 AD</p>
	Shock	<p>The feeling of a comparatively large impact or vibration when the engine is accelerated or decelerated.</p>
	Surge	<p>This is slight acceleration and deceleration feel usually felt during steady, light throttle cruise. Most notable under light loads.</p>
	Knocking	<p>A sharp sound during driving, which sounds like a hammer striking the cylinder walls. It makes poor driveability.</p>
At stopped	Run on ("Dieseling")	<p>The condition in which the engine continues to run after the ignition switch is turned to the "LOCK" (OFF) position. Also called "dieseling".</p>

DIAGNOSTIC TROUBLE CODE PROCEDURES

DTC P0010: Intake Engine Oil Control Valve Circuit

INTAKE ENGINE OIL CONTROL VALVE CIRCUIT

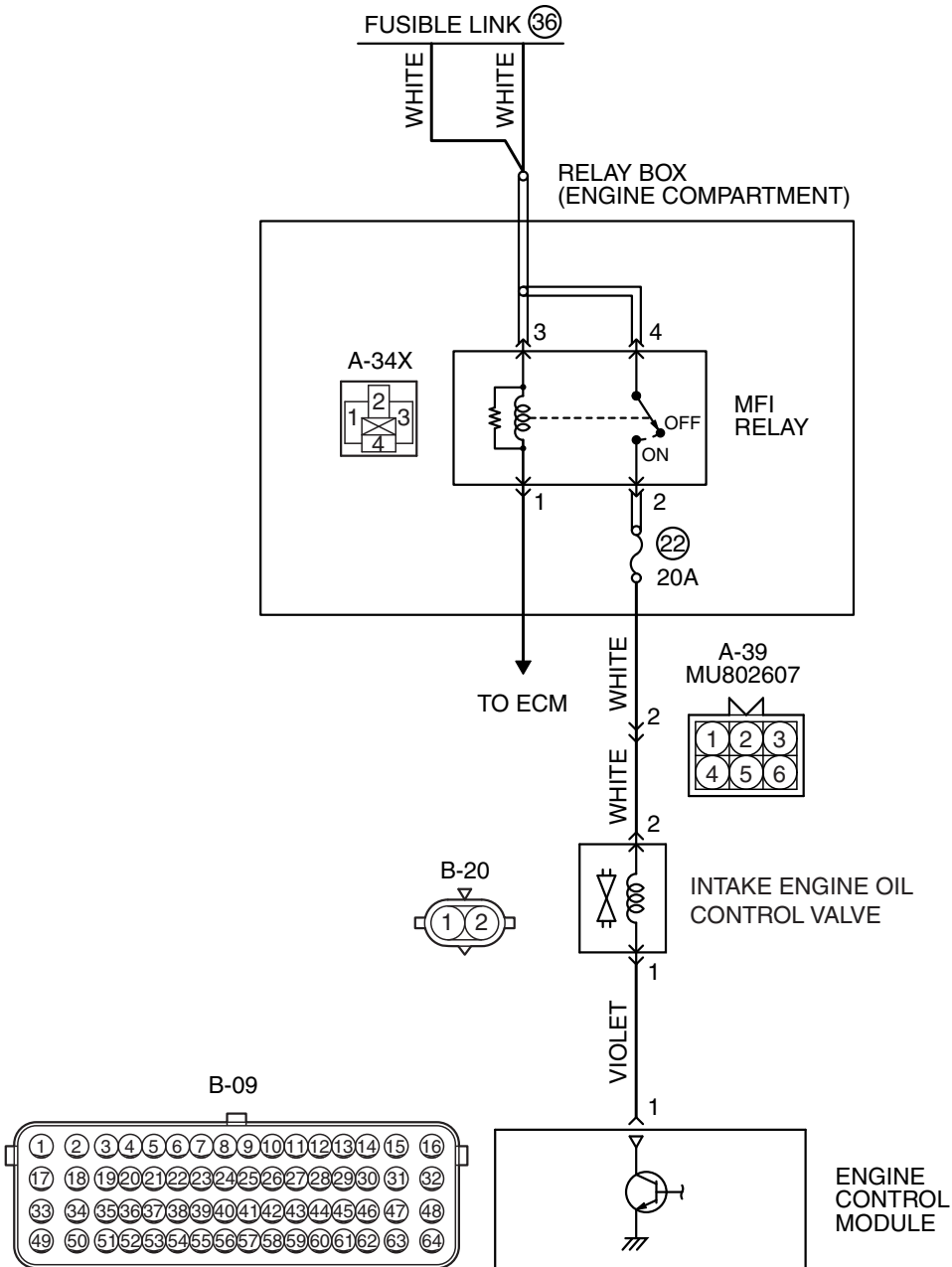

AK704290 AB

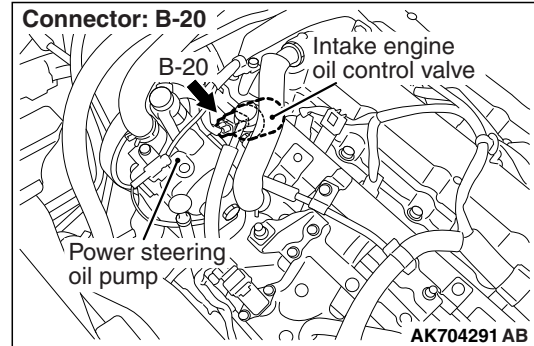
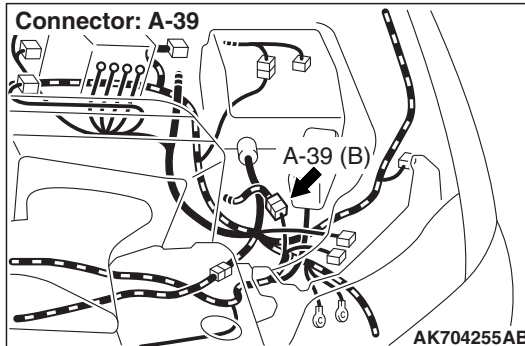
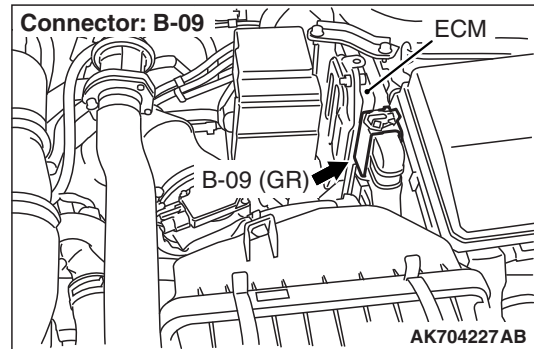
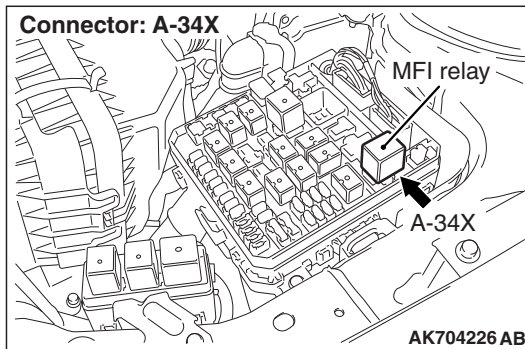

CIRCUIT OPERATION

- The intake engine oil control valve power is supplied from the MFI relay (terminal No. 2).
- The ECM controls ground intake engine oil control valve by turning the power transistor in the ECM "ON" and "OFF".

TECHNICAL DESCRIPTION

- The intake engine oil control valve change the phase angle to operate the MIVEC system in the advance or retard side in accordance with the signals from the ECM.

DESCRIPTIONS OF MONITOR METHODS

Intake engine oil control valve circuit current is out of the specified range.

MONITOR EXECUTION

Continuous

MONITOR EXECUTION CONDITIONS (Other monitor and Sensor)

Other Monitor (There is no temporary DTC stored in memory for the item monitored below)

- Not applicable

Sensor (The sensor below is determined to be normal)

- Camshaft position sensor
- Crankshaft position sensor
- Engine coolant temperature sensor
- Throttle position sensor
- Engine oil control valve

DTC SET CONDITIONS

Logic Flow Chart

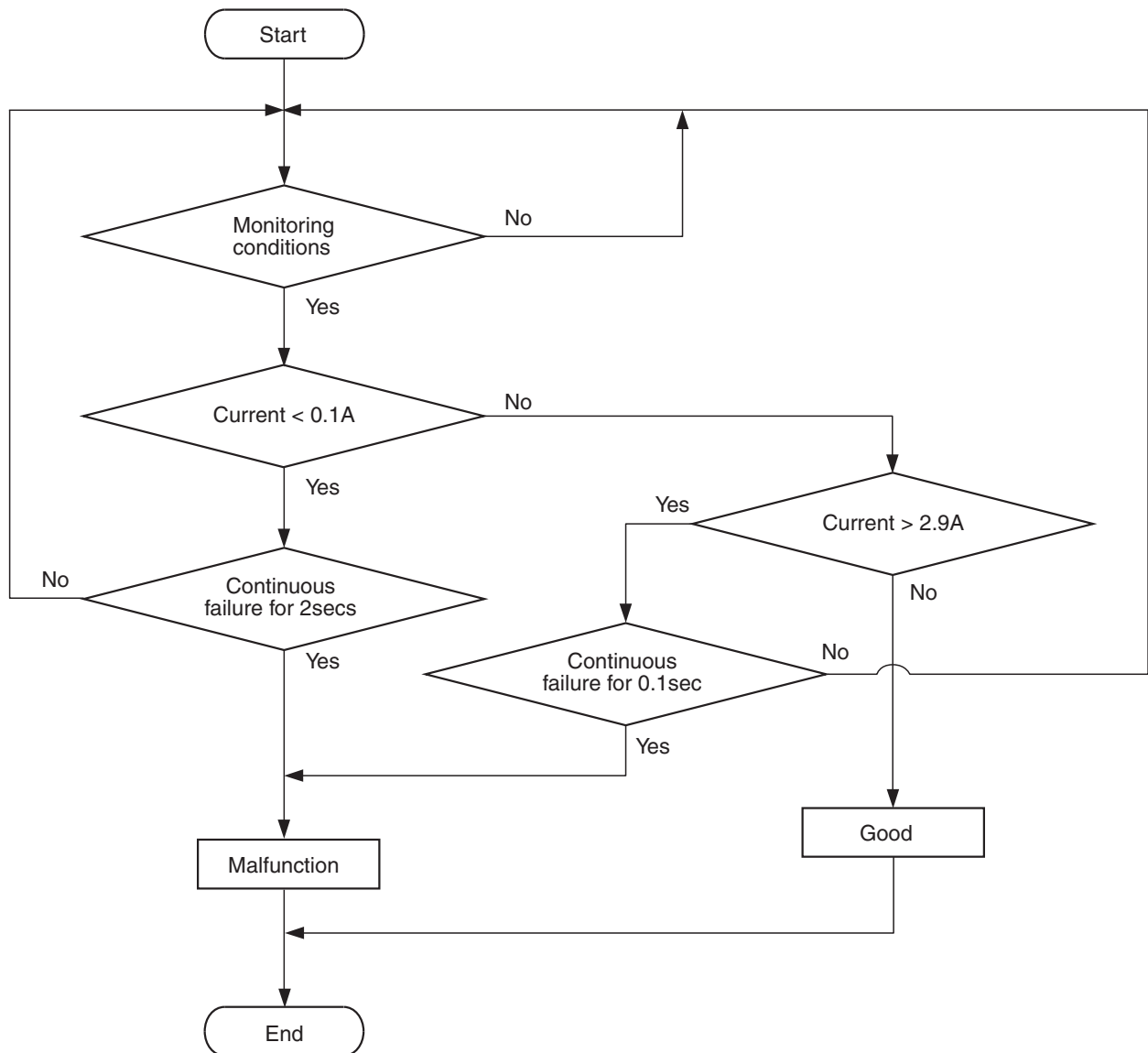

AK704777

Check Conditions

- Ignition switch is "ON" position
- Battery positive voltage is between 10 and 16.5 volts.
- ON duty cycle of the intake engine oil control valve circuit is higher than 20 percent.

Judgement Criterion

- The ECM terminal current of intake engine oil control valve circuit is less than 0.1 ampere for 2 seconds.

Check Conditions

- Ignition switch is "ON" position

- Battery positive voltage is between 10 and 16.5 volts.

Judgement Criterion

- The ECM terminal current of intake engine oil control valve circuit is higher than 2.9 amperes for 0.1 second.

FAIL-SAFE AND BACKUP FUNCTION

- V.V.T.phase angle (intake) becomes most retarded angle.

OBD-II DRIVE CYCLE PATTERN

Refer to Diagnostic Function –OBD-II Drive Cycle –
Pattern 20 [P.13A-9](#).

TROUBLESHOOTING HINTS (The most likely causes for this code to be set are:)

- Intake engine oil control valve failed.
- Open or shorted intake engine oil control valve circuit, or harness damage, or connector damage.
- ECM failed.

DIAGNOSIS

Required Special Tools:

- MB992110: Power Plant ECU Check Harness

STEP 1. Check harness connector B-20 at the intake engine oil control valve for damage.

Q: Is the harness connector in good condition?

YES : Go to Step 2.

NO : Repair or replace it. Refer to GROUP 00E, Harness Connector Inspection [P.00E-2](#). Then go to Step 10.

STEP 2. Check the intake engine oil control valve.

- (1) Disconnect the intake engine oil control valve connector B-20.
- (2) Measure the resistance between intake engine oil control valve side connector terminal No. 1 and No. 2.

Standard value: 6.9 –7.9 Ω [at 20° C (68° F)]

Q: Is the measured resistance between 6.9 and 7.9 Ω [at 20° C (68° F)]?

YES : Go to Step 3.

NO : Replace the intake engine oil control valve. Then go to Step 10.

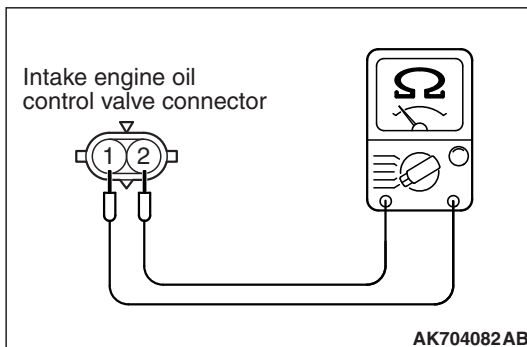

STEP 3. Measure the power supply voltage at intake engine oil control valve harness side connector B-20.

- (1) Disconnect the connector B-20 and measure at the harness side.
- (2) Turn the ignition switch to the "ON" position.
- (3) Measure the voltage between terminal No. 2 and ground.
 - Voltage should be battery positive voltage.
- (4) Turn the ignition switch to the "LOCK" (OFF) position.

Q: Is battery positive voltage (approximately 12 volts) present?

YES : Go to Step 5.

NO : Go to Step 4.

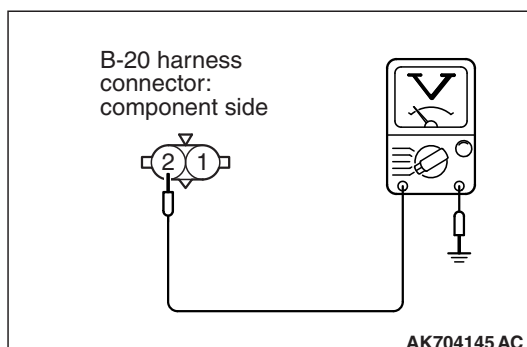

STEP 4. Check harness connector A-34X at MFI relay for damage.

Q: Is the harness connector in good condition?

YES : Check harness connector A-39 at intermediate connector for damage, and repair or replace as required. Refer to GROUP 00E, Harness Connector Inspection [P.00E-2](#). If intermediate connector is in good condition, repair harness wire between MFI relay connector A-34X (terminal No. 2) and intake engine oil control valve connector B-20 (terminal No. 2) because of open circuit or short circuit to ground. Then go to Step 10.

NO : Repair or replace it. Refer to GROUP 00E, Harness Connector Inspection [P.00E-2](#). Then go to Step 10.

STEP 5. Check harness connector B-09 at ECM for damage.

Q: Is the harness connector in good condition?

YES : Go to Step 6.

NO : Repair or replace it. Refer to GROUP 00E, Harness Connector Inspection [P.00E-2](#). Then go to Step 10.

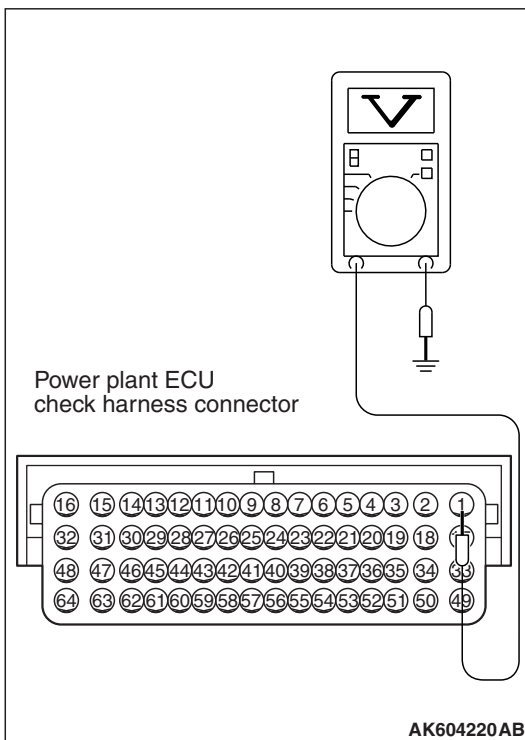
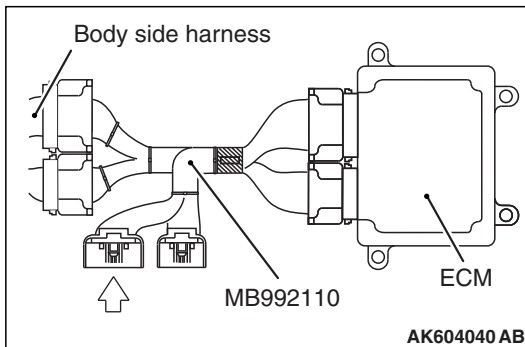

STEP 6. Measure the power supply voltage at ECM connector B-09 by using power plant ECU check harness special tool MB992110.

- (1) Disconnect all ECM connectors. Connect the power plant ECU check harness special tool MB992110 between the separated connectors.
- (2) Turn the ignition switch to the "ON" position.

- (3) Measure the voltage between terminal No. 1 and ground.
 - Voltage should be battery positive voltage.
- (4) Turn the ignition switch to the "LOCK" (OFF) position.

Q: Is battery positive voltage (approximately 12 volts) present?

YES : Go to Step 7.

NO : Repair harness wire between intake engine oil control valve connector B-20 (terminal No. 1) and ECM connector B-09 (terminal No. 1) because of open circuit or short circuit to ground. Then go to Step 10.

STEP 7. Check for harness damage between MFI relay connector A-34X (terminal No. 2) and intake engine oil control valve connector B-20 (terminal No. 2).

NOTE: Check harness after checking intermediate connector A-39. If intermediate connector is damaged, repair or replace it. Refer to GROUP 00E, Harness Connector Inspection P.00E-2. Then go to Step 10.

Q: Is the harness wire in good condition?

YES : Go to Step 8.

NO : Repair it. Then go to Step 10.

STEP 8. Check for harness damage between intake engine oil control valve connector B-20 (terminal No. 1) and ECM connector B-09 (terminal No. 1).

Q: Is the harness wire in good condition?

YES : Go to Step 9.

NO : Repair it. Then go to Step 10.

STEP 9. Check the trouble symptoms.

(1) Carry out test drive with the drive cycle pattern. Refer to Diagnostic Function –OBD-II Drive Cycle –Pattern 20 [P.13A-9](#).

(2) Check the diagnostic trouble code (DTC).

Q: Is DTC P0010 set?

YES : Replace the ECM. When the ECM is replaced, register the ID code. Refer to GROUP 42B, ID Code Registration Necessity Judgment Table <Vehicles with KOS> [P.42B-11](#) or GROUP 42C, ID Codes Registration Judgment Table <Vehicles with WCM> [P.42C-9](#). Then go to Step 10.

NO : It can be assumed that this malfunction is intermittent. Refer to GROUP 00, How to Use Troubleshooting/Inspection Service Points –How to Cope with Intermittent Malfunctions [P.00-15](#).

STEP 10. Test the OBD-II drive cycle.

(1) Carry out test drive with the drive cycle pattern. Refer to Diagnostic Function –OBD-II Drive Cycle –Pattern 20 [P.13A-9](#).

(2) Check the diagnostic trouble code (DTC).

Q: Is DTC P0010 set?

YES : Retry the troubleshooting.

NO : The inspection is complete.

DTC P0011: Intake Variable Valve Timing System Target Error

TECHNICAL DESCRIPTION

- The ECM checks the variable valve timing system for malfunction.

DESCRIPTIONS OF MONITOR METHODS

The phase angle of the intake camshaft is higher than the specified value.

MONITOR EXECUTION

Continuous

MONITOR EXECUTION CONDITIONS (Other monitor and Sensor)

Other Monitor (There is no temporary DTC stored in memory for the item monitored below)

- Not applicable

Sensor (The sensor below is determined to be normal)

- Camshaft position sensor
- Crankshaft position sensor
- Engine coolant temperature sensor
- Throttle position sensor
- Engine oil control valve

DTC SET CONDITIONS

Logic Flow Chart

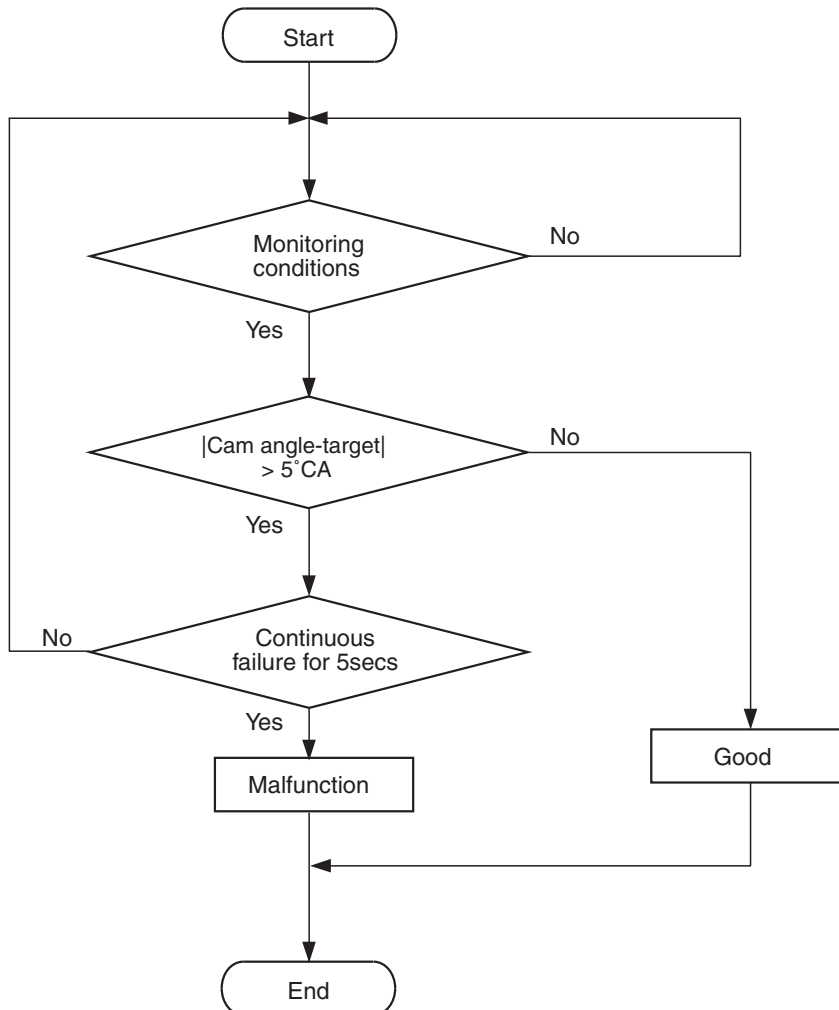

Cam angle: Intake valve open timing (intake side)
Exhaust valve close timing (exhaust side)

AK704222

Check Conditions

- More than 20 seconds have passed since the engine starting sequence was completed.
- Engine speed is 1,188 r/min or more.
- Engine coolant temperature is higher than 76° C (169° F).

Judgment Criterion

- The difference between the actual intake valve opening timing and the intake valve target opening timing is more than 5 degrees for 5 seconds.

FAIL-SAFE AND BACKUP FUNCTION

- None

OBD-II DRIVE CYCLE PATTERN

Refer to Diagnostic Function –OBD-II Drive Cycle – Pattern 20 [P.13A-9](#).

TROUBLESHOOTING HINTS (The most likely causes for this code to be set are:)

- Intake engine oil control valve failed.
- Oil passage of variable valve timing control system clogged.
- Intake variable valve timing sprocket operation mechanism stuck.
- ECM failed.

DIAGNOSIS

Required Special Tools

- MB991958: Scan tool (M.U.T.-III Sub Assembly)
 - MB991824: V.C.I.
 - MB991827: USB Cable
 - MB991910: Main Harness A

STEP 1. Using scan tool MB991958, read the diagnostic trouble code (DTC).

⚠ CAUTION

To prevent damage to scan tool MB991958, always turn the ignition switch to the "LOCK" (OFF) position before connecting or disconnecting scan tool MB991958.

- (1) Connect scan tool MB991958 to the data link connector.
- (2) Turn the ignition switch to the "ON" position.
- (3) Set scan tool MB991958, read the DTC.
- (4) Turn the ignition switch to the "LOCK" (OFF) position.

Q: Is the diagnostic trouble code other than P0011 set?

- YES** : Refer to, Diagnostic Trouble Code Chart [P.13A-48](#).
NO : Go to Step 2.

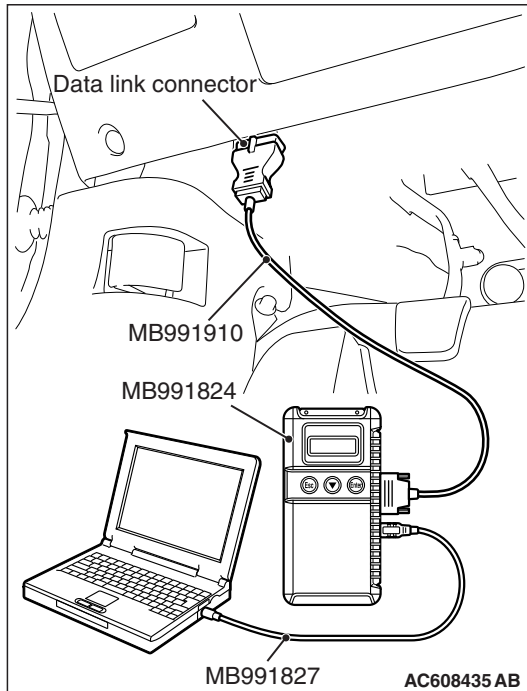

STEP 2. Check intake engine oil control valve itself.

- Check intake engine oil control valve itself (Refer to Engine Oil Control Valve Check [P.13A-880](#)).

Q: Is the check result normal?

- YES** : Go to Step 3.
NO : Replace intake engine oil control valve. Then go to Step 6.

STEP 3. Check oil passage of intake variable valve timing control system for being clogged.

Q: Is the check result normal?

- YES** : Go to Step 4.
NO : Repair it. Then go to Step 6.

STEP 4. Check intake variable valve timing sprocket operation mechanism for being stuck.

Q: Is the check result normal?

YES : Go to Step 5.

NO : Repair it. Then go to Step 6.

STEP 5. Check the trouble symptoms.

(1) Carry out test drive with the drive cycle pattern. Refer to Diagnostic Function –OBD-II Drive Cycle –Pattern 20 [P.13A-9](#).

(2) Check the diagnostic trouble code (DTC).

Q: Is DTC P0011 set?

YES : Replace the ECM. When the ECM is replaced, register the ID code. Refer to GROUP 42B, ID Code Registration Necessity Judgment Table <Vehicles with KOS> [P.42B-11](#) or GROUP 42C, ID Codes Registration Judgment Table <Vehicles with WCM> [P.42C-9](#). Then go to Step 6.

NO : It can be assumed that this malfunction is intermittent. Refer to GROUP 00, How to Use Troubleshooting/Inspection Service Points –How to Cope with Intermittent Malfunctions [P.00-15](#).

STEP 6. Test the OBD-II drive cycle.

(1) Carry out a test drive with the drive cycle pattern. Refer to Diagnostic Function –OBD-II Drive Cycle –Pattern 20 [P.13A-9](#).

(2) Check the diagnostic trouble code (DTC).

Q: Is DTC P0011 set?

YES : Retry the troubleshooting.

NO : The inspection is complete.

DTC P0012: Camshaft Position –Timing Over-Retarded

TECHNICAL DESCRIPTION

- If the vehicle equipped with 4B11-T/C engine continues the rough driving like competitive running (the running that constantly repeats the cycle of the full opened position of the accelerator pedal and the full closed position of the accelerator pedal.), the amount of carbon mixed into the engine oil tends to increase. This can possibly cause the timing chain to gradually elongate. To prevent this, the function or logic monitoring the amount of elongation of the timing chain is integrated into the ECM. The details are shown in timing chain maintenance (Refer to GROUP 00, Precautions Before Service –Timing Chain Maintenance [P.00-37](#)).

DTC SET CONDITIONS**Check Condition**

- Ignition switch is "ON" position.

Judgment Criterion

- The learning value for the current phase angle of V.V.T. at the intake (retard angle) side and the exhaust (advanced angle) side is different from the initial phase angle of V.V.T. by more than the specified value.

FAIL-SAFE AND BACKUP FUNCTION

- None

TROUBLESHOOTING HINTS (The most likely causes for this code to be set are:)

- Timing chain elongated.

DIAGNOSIS

STEP 1. Timing Chain Elongation Visual Check

Refer to GROUP 11A, On-vehicle Service –Timing Chain Elongation Visual Check [P.11A-17](#).

Q: Are there any abnormalities?

- YES** : Initialize the learning value for the elongation of the timing chain. Refer to GROUP 00, Precautions Before Service –Timing Chain Maintenance [P.00-37](#).
- NO** : Replace the timing chain and the oil pump chain. Then initialize the learning value for the elongation of the timing chain. Refer to GROUP 00, Precautions Before Service –Timing Chain Maintenance [P.00-37](#).

DTC P0013: Exhaust Engine Oil Control Valve Circuit

EXHAUST ENGINE OIL CONTROL VALVE CIRCUIT

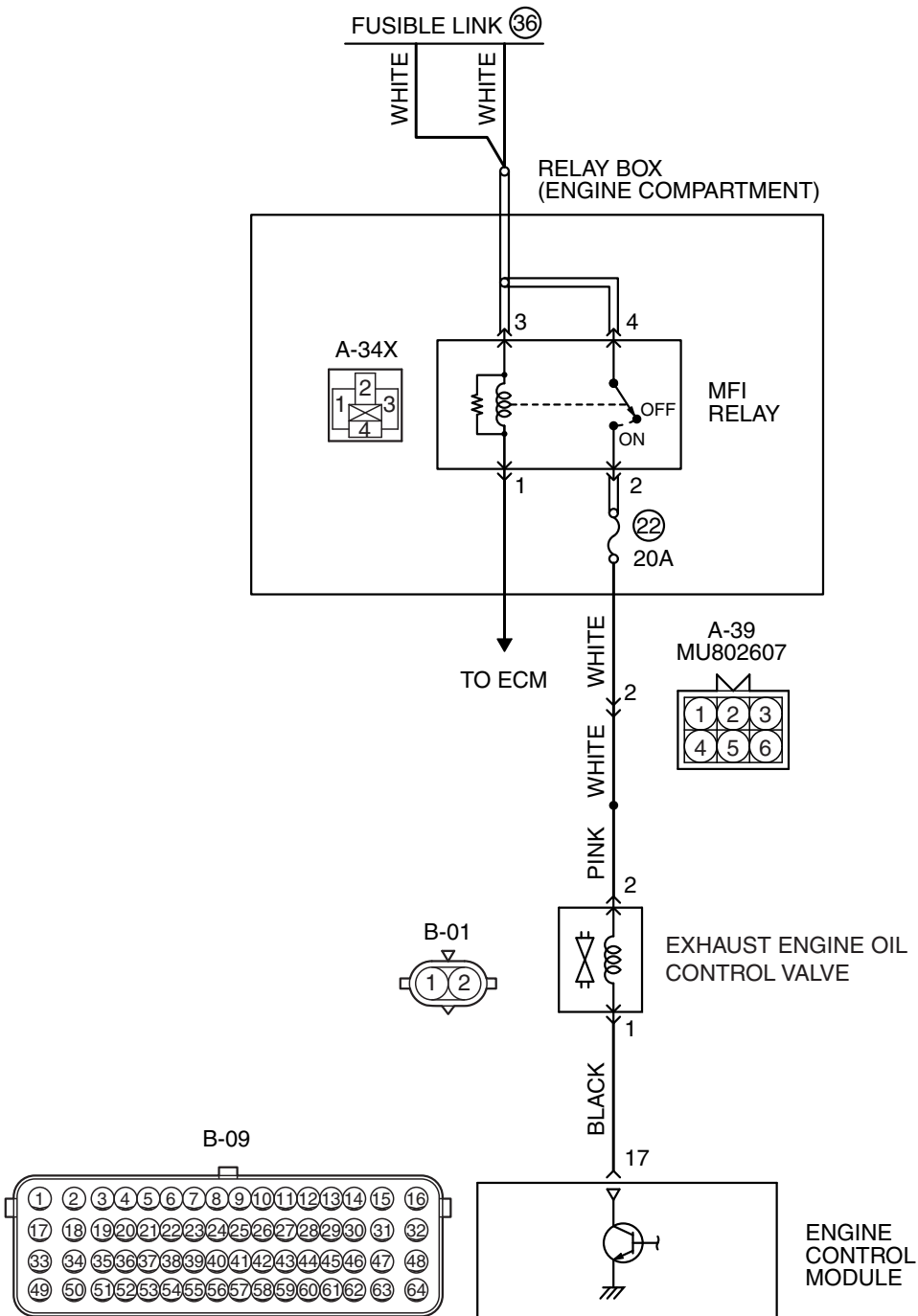

AK704292 AB

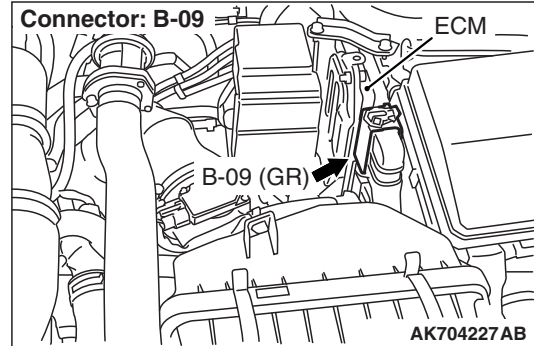
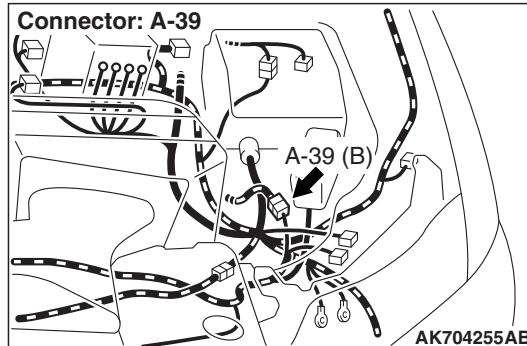
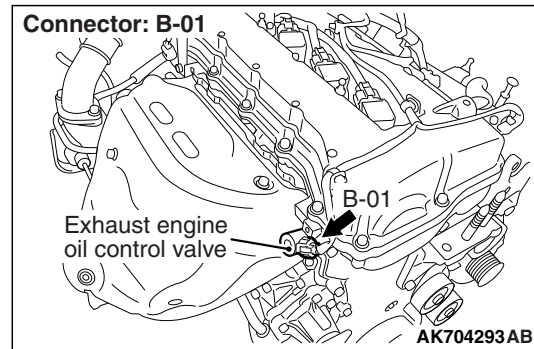
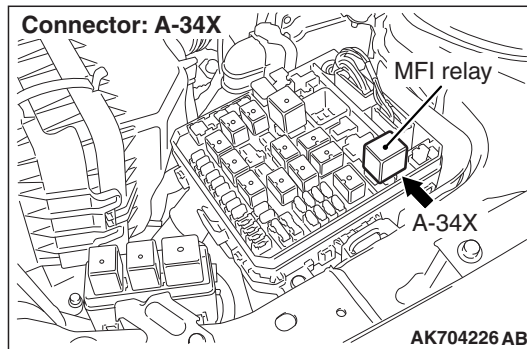

CIRCUIT OPERATION

- The exhaust engine oil control valve power is supplied from the MFI relay (terminal No. 2).
- The ECM controls ground exhaust engine oil control valve by turning the power transistor in the ECM "ON" and "OFF".

TECHNICAL DESCRIPTION

- The exhaust engine oil control valve change the phase angle to operate the MIVEC system in the advance or retard side in accordance with the signals from the ECM.

DESCRIPTIONS OF MONITOR METHODS

Exhaust engine oil control valve circuit current is less than specified value.

MONITOR EXECUTION

Continuous

MONITOR EXECUTION CONDITIONS (Other monitor and Sensor)

Other Monitor (There is no temporary DTC stored in memory for the item monitored below)

- Not applicable

Sensor (The sensor below is determined to be normal)

- Camshaft position sensor
- Crankshaft position sensor
- Engine coolant temperature sensor
- Throttle position sensor
- Engine oil control valve

DTC SET CONDITIONS

Logic Flow Chart

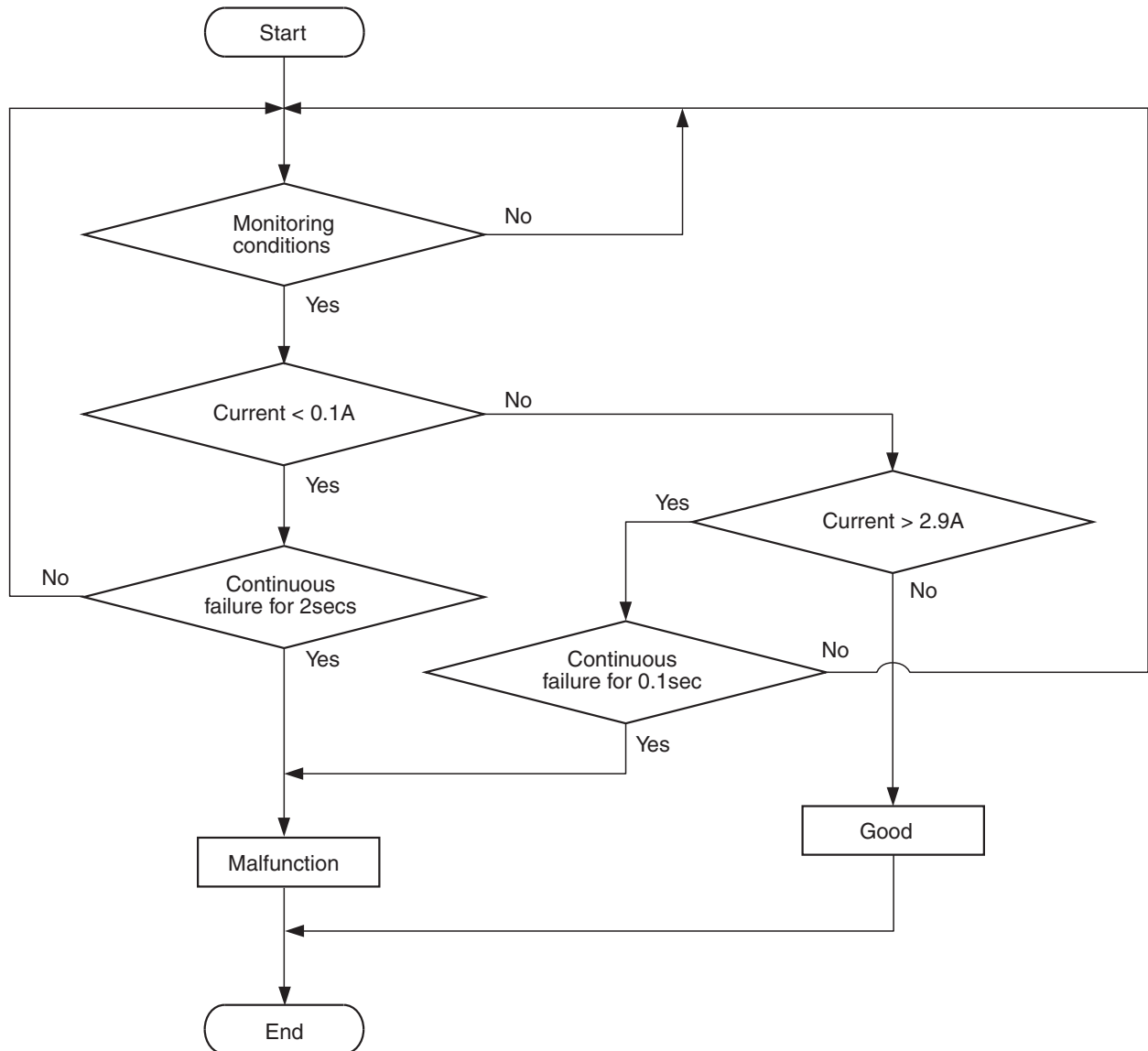

AK704777

Check Conditions

- Ignition switch is "ON" position.
- Battery positive voltage is between 10 and 16.5 volts.
- ON duty cycle of the exhaust engine oil control valve circuit is higher than 20 percent.

Judgement Criterion

- The ECM terminal current of exhaust engine oil control valve circuit is less than 0.1 ampere for 2 seconds.

Check Conditions

- Ignition switch is "ON" position

- Battery positive voltage is between 10 and 16.5 volts.

Judgement Criterion

- The ECM terminal current of exhaust engine oil control valve circuit is higher than 2.9 amperes for 0.1 second.

FAIL-SAFE AND BACKUP FUNCTION

- V.V.T.phase angle (exhaust) becomes most advanced angle.

OBD-II DRIVE CYCLE PATTERN

Refer to Diagnostic Function –OBD-II Drive Cycle –
Pattern 20 [P.13A-9](#).

TROUBLESHOOTING HINTS (The most likely causes for this code to be set are:)

- Exhaust engine oil control valve failed.
- Open or shorted exhaust engine oil control valve circuit, or harness damage, or connector damage.
- ECM failed.

DIAGNOSIS

Required Special Tools:

- MB992110:Power Plant ECU CHeck Harness

STEP 1. Check harness connector B-01 at the exhaust engine oil control valve for damage.

Q: Is the harness connector in good condition?

YES : Go to Step 2.

NO : Repair or replace it. Refer to GROUP 00E, Harness Connector Inspection [P.00E-2](#). Then go to Step 10.

STEP 2. Check the exhaust engine oil control valve.

- (1) Disconnect the exhaust engine oil control valve connector B-01.
- (2) Measure the resistance between exhaust engine oil control valve side connector terminal No. 1 and No. 2.

Standard value: 6.9 –7.9 Ω [at 20° C (68° F)]

Q: Is the measured resistance between 6.9 and 7.9 Ω [at 20° C (68° F)]?

YES : Go to Step 3.

NO : Replace the exhaust engine oil control valve. Then go to Step 10.

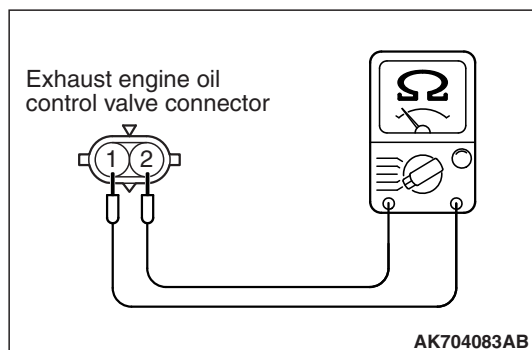

STEP 3. Measure the power supply voltage at exhaust engine oil control valve harness side connector B-01.

- (1) Disconnect the connector B-01 and measure at the harness side.
- (2) Turn the ignition switch to the "ON" position.
- (3) Measure the voltage between terminal No. 2 and ground.
 - Voltage should be battery positive voltage.
- (4) Turn the ignition switch to the "LOCK" (OFF) position.

Q: Is battery positive voltage (approximately 12 volts) present?

YES : Go to Step 5.

NO : Go to Step 4.

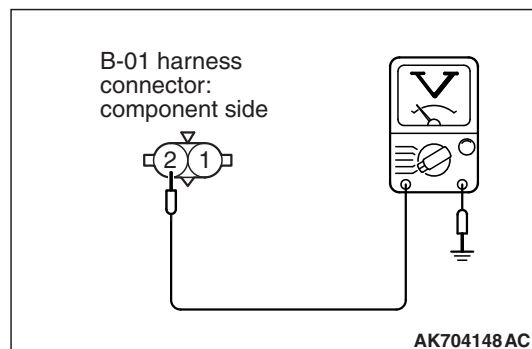

STEP 4. Check harness connector A-34X at MFI relay for damage.

Q: Is the harness connector in good condition?

YES : Check harness connector A-39 at intermediate connector for damage, and repair or replace as required. Refer to GROUP 00E, Harness Connector Inspection [P.00E-2](#). If intermediate connector is in good condition, repair harness wire between MFI relay connector A-34X (terminal No. 2) and exhaust engine oil control valve connector B-01 (terminal No. 2) because of open circuit or short circuit to ground. Then go to Step 10.

NO : Repair or replace it. Refer to GROUP 00E, Harness Connector Inspection [P.00E-2](#). Then go to Step 10.

STEP 5. Check harness connector B-09 at ECM for damage.

Q: Is the harness connector in good condition?

YES : Go to Step 6.

NO : Repair or replace it. Refer to GROUP 00E, Harness Connector Inspection [P.00E-2](#). Then go to Step 10.

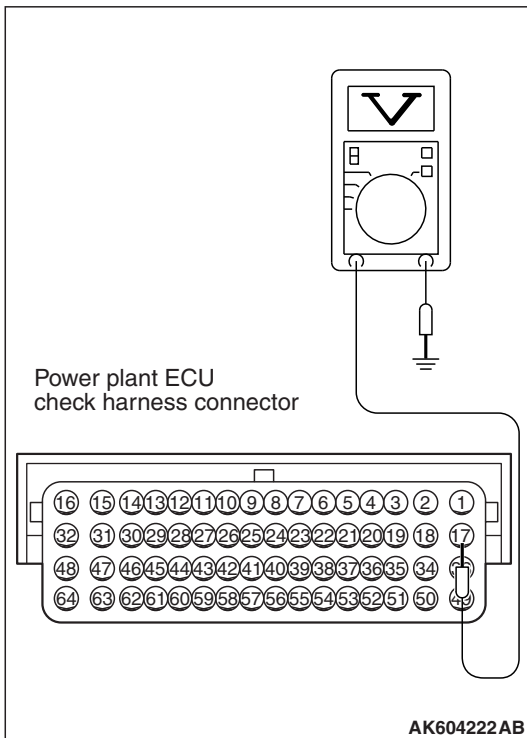
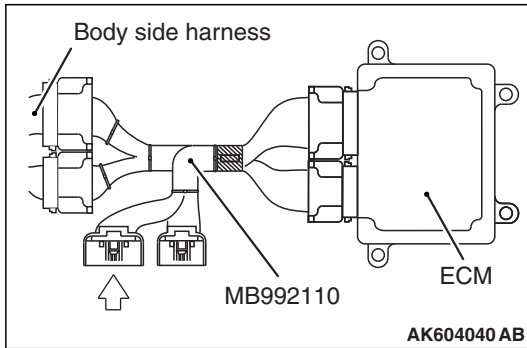

STEP 6. Measure the power supply voltage at ECM connector B-09 by using power plant ECU check harness special tool MB992110.

(1) Disconnect all ECM connectors. Connect the power plant ECU check harness special tool MB992110 between the separated connectors.

(2) Turn the ignition switch to the "ON" position.

(3) Measure the voltage between terminal No. 17 and ground.

- Voltage should be battery positive voltage.

(4) Turn the ignition switch to the "LOCK" (OFF) position.

Q: Is battery positive voltage (approximately 12 volts) present?

YES : Go to Step 7.

NO : Repair harness wire between exhaust engine oil control valve connector B-01 (terminal No. 1) and ECM connector B-09 (terminal No. 17) because of open circuit or short circuit to ground. Then go to Step 10.

STEP 7. Check for harness damage between MFI relay connector A-34X (terminal No. 2) and exhaust engine oil control valve connector B-01 (terminal No. 2).

NOTE: Check harness after checking intermediate connector A-39. If intermediate connector is damaged, repair or replace it. Refer to GROUP 00E, Harness Connector Inspection P.00E-2. Then go to Step 10.

Q: Is the harness wire in good condition?

YES : Go to Step 8.

NO : Repair it. Then go to Step 10.

STEP 8. Check for harness damage between exhaust engine oil control valve connector B-01 (terminal No. 1) and ECM connector B-09 (terminal No. 17).

Q: Is the harness wire in good condition?

YES : Go to Step 9.

NO : Repair it. Then go to Step 10.

STEP 9. Check the trouble symptoms.

(1) Carry out test drive with the drive cycle pattern. Refer to Diagnostic Function –OBD-II Drive Cycle –Pattern 20 [P.13A-9](#).

(2) Check the diagnostic trouble code (DTC).

Q: Is DTC P0013 set?

YES : Replace the ECM. When the ECM is replaced, register the ID code. Refer to GROUP 42B, ID Code Registration Necessity Judgment Table <Vehicles with KOS> [P.42B-11](#) or GROUP 42C, ID Codes Registration Judgment Table <Vehicles with WCM> [P.42C-9](#). Then go to Step 10.

NO : It can be assumed that this malfunction is intermittent. Refer to GROUP 00, How to Use Troubleshooting/Inspection Service Points –How to Cope with Intermittent Malfunctions [P.00-15](#).

STEP 10. Test the OBD-II drive cycle.

(1) Carry out test drive with the drive cycle pattern. Refer to Diagnostic Function –OBD-II Drive Cycle –Pattern 20 [P.13A-9](#).

(2) Check the diagnostic trouble code (DTC).

Q: Is DTC P0013 set?

YES : Retry the troubleshooting.

NO : The inspection is complete.

DTC P0014: Exhaust Variable Valve Timing System Target Error

TECHNICAL DESCRIPTION

- The ECM checks the variable valve timing system for malfunction.

DESCRIPTIONS OF MONITOR METHODS

The phase angle of the exhaust camshaft is higher than the specified value.

MONITOR EXECUTION

Continuous

MONITOR EXECUTION CONDITIONS (Other monitor and Sensor)

Other Monitor (There is no temporary DTC stored in memory for the item monitored below)

- Not applicable

Sensor (The sensor below is determined to be normal)

- Camshaft position sensor
- Crankshaft position sensor
- Engine coolant temperature sensor
- Throttle position sensor
- Engine oil control valve

DTC SET CONDITIONS

Logic Flow Chart

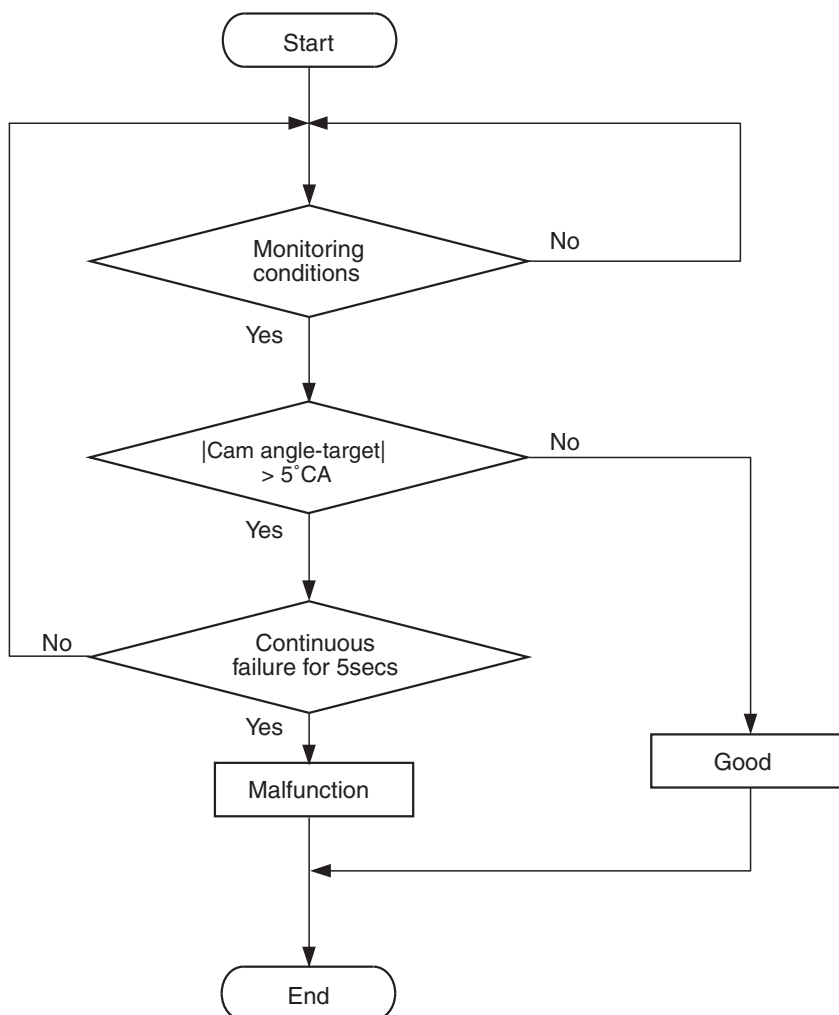

Cam angle: Intake valve open timing (intake side)
Exhaust valve close timing (exhaust side)

AK704222

Check Conditions

- More than 20 seconds have passed since the engine starting sequence was completed.
- Engine speed is 1,188 r/min or more.
- Engine coolant temperature is higher than 76° C (169° F).

Judgment Criterion

- The difference between the actual exhaust valve closing timing and the exhaust valve target closing timing is more than 5 degrees for 5 seconds.

FAIL-SAFE AND BACKUP FUNCTION

- None

OBD-II DRIVE CYCLE PATTERN

Refer to Diagnostic Function –OBD-II Drive Cycle – Pattern 20 [P.13A-9](#).

TROUBLESHOOTING HINTS (The most likely causes for this code to be set are:)

- Exhaust engine oil control valve failed.
- Oil passage of variable valve timing control system clogged.
- Exhaust variable valve timing sprocket operation mechanism stuck.
- ECM failed.

DIAGNOSIS

Required Special Tools

- MB991958: Scan tool (M.U.T.-III Sub Assembly)
 - MB991824: V.C.I.
 - MB991827: USB Cable
 - MB991910: Main Harness A

STEP 1. Using scan tool MB991958, read the diagnostic trouble code (DTC).

⚠ CAUTION

To prevent damage to scan tool MB991958, always turn the ignition switch to the "LOCK" (OFF) position before connecting or disconnecting scan tool MB991958.

- (1) Connect scan tool MB991958 to the data link connector.
- (2) Turn the ignition switch to the "ON" position.
- (3) Set scan tool MB991958, read the DTC.
- (4) Turn the ignition switch to the "LOCK" (OFF) position.

Q: Is the diagnostic trouble code other than P0014 set?

- YES :** Refer to, Diagnostic Trouble Code Chart [P.13A-48](#).
NO : Go to Step 2.

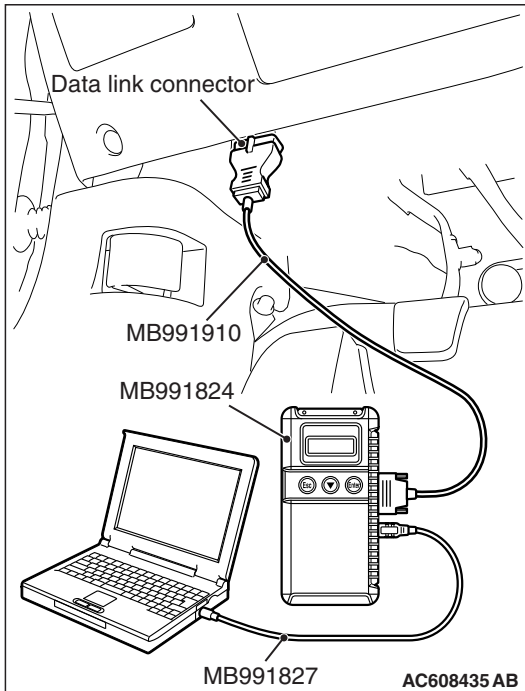

STEP 2. Check exhaust engine oil control valve itself.

- Check exhaust engine oil control valve itself (Refer to Engine Oil Control Valve Check [P.13A-880](#)).

Q: Is the check result normal?

- YES :** Go to Step 3.
NO : Replace exhaust engine oil control valve. Then go to Step 6.

STEP 3. Check oil passage of exhaust variable valve timing control system for being clogged.

Q: Is the check result normal?

- YES :** Go to Step 4.
NO : Repair it. Then go to Step 6.

STEP 4. Check exhaust variable valve timing sprocket operation mechanism for being stuck.

Q: Is the check result normal?

- YES :** Go to Step 5.
NO : Repair it. Then go to Step 6.

STEP 5. Check the trouble symptoms.

- (1) Carry out test drive with the drive cycle pattern. Refer to Diagnostic Function –OBD-II Drive Cycle –Pattern 20 [P.13A-9](#).
- (2) Check the diagnostic trouble code (DTC).

Q: Is DTC P0014 set?

YES : Replace the ECM. When the ECM is replaced, register the ID code. Refer to GROUP 42B, ID Code Registration Necessity Judgment Table <Vehicles with KOS> [P.42B-11](#) or GROUP 42C, ID Codes Registration Judgment Table <Vehicles with WCM> [P.42C-9](#). Then go to Step 6.

NO : It can be assumed that this malfunction is intermittent. Refer to GROUP 00, How to Use Troubleshooting/Inspection Service Points –How to Cope with Intermittent Malfunctions [P.00-15](#).

STEP 6. Test the OBD-II drive cycle.

- (1) Carry out a test drive with the drive cycle pattern. Refer to Diagnostic Function –OBD-II Drive Cycle –Pattern 20 [P.13A-9](#).
- (2) Check the diagnostic trouble code (DTC).

Q: Is DTC P0014 set?

YES : Retry the troubleshooting.

NO : The inspection is complete.

DTC P0016: Crankshaft/camshaft (intake) Position Sensor Phase Problem

TECHNICAL DESCRIPTION

- The ECM checks the variable valve timing system for malfunction.

DESCRIPTIONS OF MONITOR METHODS

The open timing of the intake valve is faster or slower than the specified value.

MONITOR EXECUTION

Continuous

**MONITOR EXECUTION CONDITIONS
(Other monitor and Sensor)**

Other Monitor (There is no temporary DTC stored in memory for the item monitored below)

- Not applicable

Sensor (The sensor below is determined to be normal)

- Camshaft position sensor
- Crankshaft position sensor
- Engine coolant temperature sensor
- Throttle position sensor
- Engine oil control valve

DTC SET CONDITIONS

Logic Flow Chart

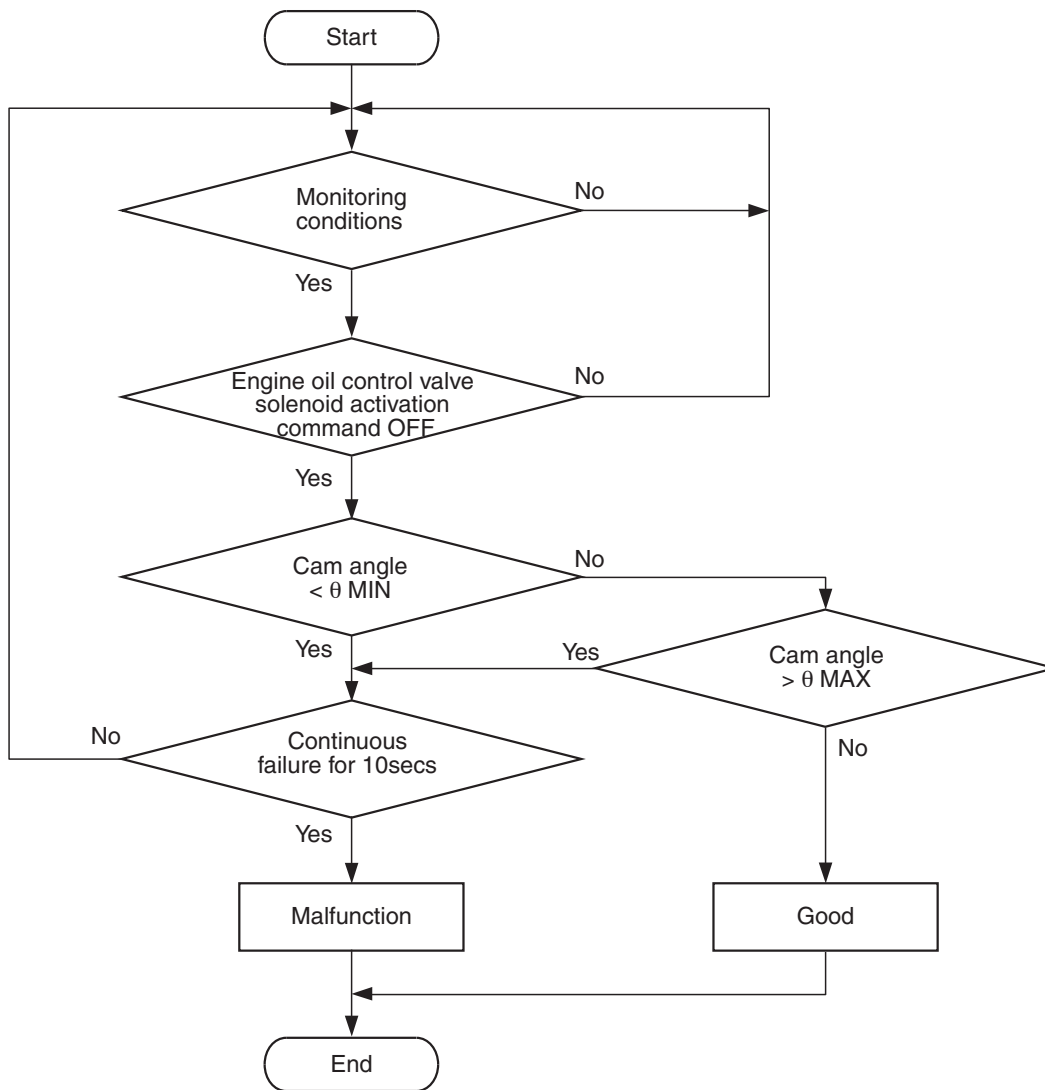

Cam angle: Intake valve open timing (intake side)
Exhaust valve close timing (exhaust side)
θ MAX : Maximum threshold value
θ MIN : Minimum threshold value

AK900350

Check Conditions

- Engine speed is between 594 r/min and 1,500 r/min.
- Engine coolant temperature is between 20° C (68° F) and 88° C (190° F).
- Intake engine oil control valve is "OFF".
- 1 second has elapsed after the above mentions have been met.

Judgment Criterion

- The open timing of the intake valve is faster than -17.0 degrees (ATDC) for 10 seconds.
- or
- The open timing of the intake valve is slower than -3.9 degrees (ATDC) for 10 seconds.

FAIL-SAFE AND BACKUP FUNCTION

- None

OBD-II DRIVE CYCLE PATTERN

Refer to Diagnostic Function –OBD-II Drive Cycle –
Pattern 20 P.13A-9.

TROUBLESHOOTING HINTS (The most likely causes for this code to be set are:)

- Timing chain in out of place.
- Loose timing chain.
- Intake variable valve timing sprocket tooth coming off.
- ECM failed.

DIAGNOSIS**Required Special Tools**

- MB991709: Test Harness
- MB992110: Power Plant ECU Check Harness

STEP 1. Using the oscilloscope, measure output wave pattern at crankshaft position sensor and intake camshaft position sensor.

- (1) Disconnect the crankshaft position sensor connector B-13 and connect the test harness special tool (MB991709) between the separated connectors.
- (2) Connect the oscilloscope probe to the crankshaft position sensor side connector terminal No. 3.
- (3) Disconnect the intake camshaft position sensor connector B-07, and connect test harness special tool (MB991709) between the separated connectors.

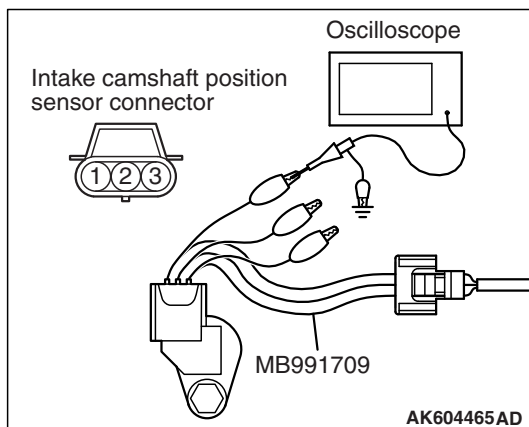
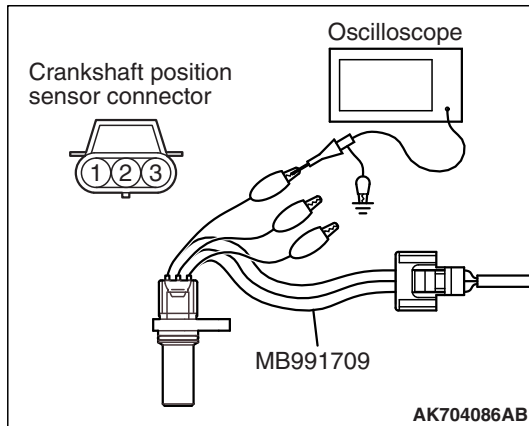

- (4) Connect the oscilloscope probe to the intake camshaft position sensor side connector terminal No. 3.

NOTE: When measuring with the ECM side connector, disconnect all ECM connectors. Connect the check harness special tool (MB992110) between the separated connectors. Then connect the oscilloscope probe to the check harness connector terminal No. 8 (crankshaft position sensor) and terminal No. 14 (intake camshaft position sensor).

- (5) Start the engine and run at idle.

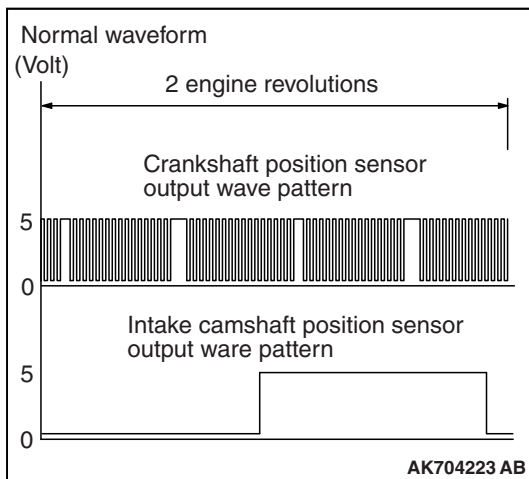

- (6) Check the waveform.
- The waveform should show a pattern similar to the illustration.
- (7) Turn the ignition switch to the "LOCK" (OFF) position.

Q: Is the waveform normal?

- YES** : Go to Step 2.
NO : Go to Step 3.

STEP 2. Check the trouble symptoms.

- (1) Carry out a test drive with the drive cycle pattern. Refer to Diagnostic Function –OBD-II Drive Cycle –Pattern 20 [P.13A-9](#).
- (2) Check the diagnostic trouble code (DTC).

Q: Is DTC P0016 set?

- YES** : Replace the ECM. When the ECM is replaced, register the ID code. Refer to GROUP 42B, ID Code Registration Necessity Judgment Table <Vehicles with KOS> [P.42B-11](#) or GROUP 42C, ID Codes Registration Judgment Table <Vehicles with WCM> [P.42C-9](#). Then go to Step 4.
- NO** : It can be assumed that this malfunction is intermittent. Refer to GROUP 00, How to Use Troubleshooting/ Inspection Service Points –How to Cope with Intermittent Malfunctions [P.00-15](#).

STEP 3. Check timing mark on the timing chain.

Q: Is timing chain in out of place?

- YES** : Repair it. Then go to Step 4.
- NO** : Check the following items, and repair or replace the defective items.
- a. Check the timing chain loose.
 - b. Check the intake variable valve timing sprocket tooth coming off.
- Then go to Step 4.

STEP 4. Test the OBD-II drive cycle.

- (1) Carry out a test drive with the drive cycle pattern. Refer to Diagnostic Function –OBD-II Drive Cycle –Pattern 20 [P.13A-9](#).
- (2) Check the diagnostic trouble code (DTC).

Q: Is DTC P0016 set?

- YES** : Retry the troubleshooting.
- NO** : The inspection is complete.

DTC P0017: Crankshaft/camshaft (exhaust) Position Sensor Phase Problem

TECHNICAL DESCRIPTION

- The ECM checks the variable valve timing system for malfunction.

DESCRIPTIONS OF MONITOR METHODS

The close timing of the exhaust valve is faster or slower than the specified value.

MONITOR EXECUTION

Continuous

**MONITOR EXECUTION CONDITIONS
(Other monitor and Sensor)**

Other Monitor (There is no temporary DTC stored in memory for the item monitored below)

- Not applicable

Sensor (The sensor below is determined to be normal)

- Camshaft position sensor
- Crankshaft position sensor
- Engine coolant temperature sensor
- Throttle position sensor
- Engine oil control valve

DTC SET CONDITIONS

Logic Flow Chart

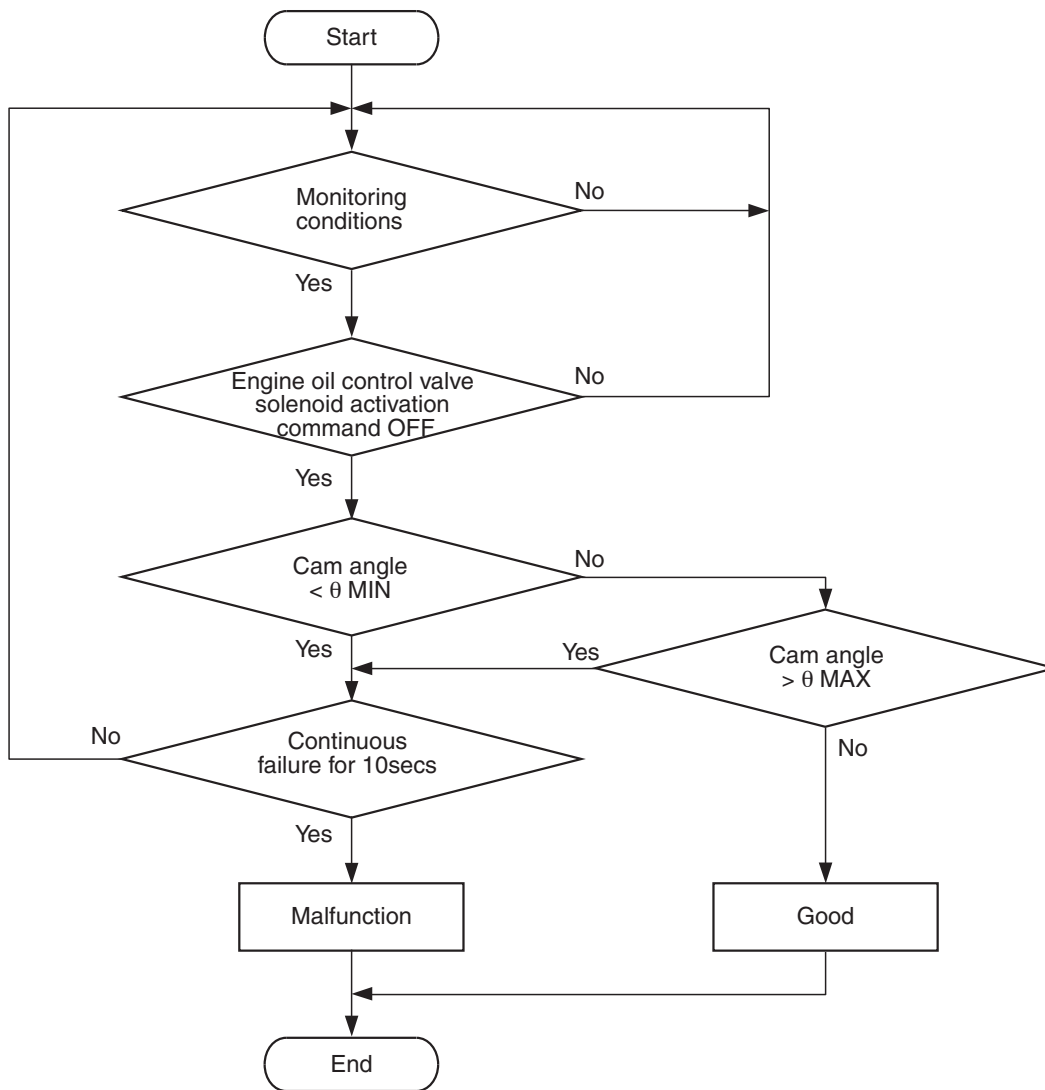

Cam angle: Intake valve open timing (intake side)
Exhaust valve close timing (exhaust side)
θ MAX : Maximum threshold value
θ MIN : Minimum threshold value

AK900350

Check Conditions

- Engine speed is between 594 r/min and 1,500 r/min.
- Engine coolant temperature is between 20° C (68° F) and 88° C (190° F).
- Exhaust engine oil control valve is "OFF".
- 1 second has elapsed after the above mentions have been met.

Judgment Criterion

- The close timing of the exhaust valve is faster than -7.7 degrees (ATDC) for 10 seconds.
- or
- The close timing of the exhaust valve is slower than 5.4 degrees (ATDC) for 10 seconds.

FAIL-SAFE AND BACKUP FUNCTION

- None

OBD-II DRIVE CYCLE PATTERN

Refer to Diagnostic Function –OBD-II Drive Cycle –
Pattern 20 P.13A-9.

TROUBLESHOOTING HINTS (The most likely causes for this code to be set are:)

- Timing chain in out of place.
- Loose timing chain.
- Exhaust variable valve timing sprocket tooth coming off.
- ECM failed.

DIAGNOSIS**Required Special Tools**

- MB991709: Test Harness
- MB992110: Power Plant ECU Check Harness

STEP 1. Using the oscilloscope, measure output wave pattern at crankshaft position sensor and exhaust camshaft position sensor.

- (1) Disconnect the crankshaft position sensor connector B-13 and connect the test harness special tool (MB991709) between the separated connectors.
- (2) Connect the oscilloscope probe to the crankshaft position sensor side connector terminal No. 3.
- (3) Disconnect the exhaust camshaft position sensor connector B-05, and connect test harness special tool (MB991709) between the separated connectors.

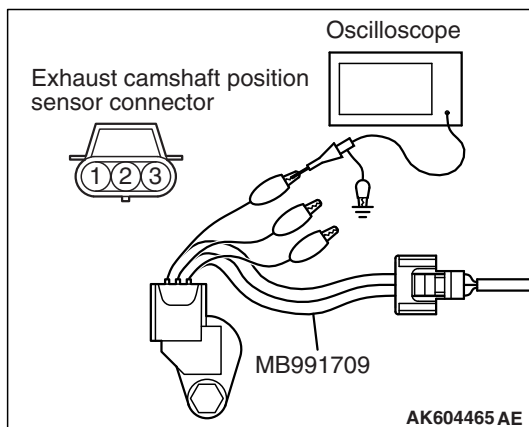
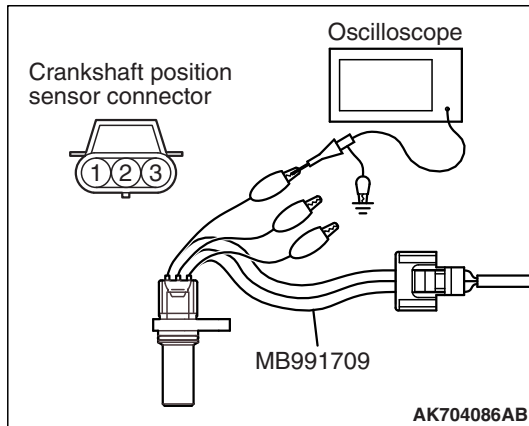

- (4) Connect the oscilloscope probe to the exhaust camshaft position sensor side connector terminal No. 3.

NOTE: When measuring with the ECM side connector, disconnect all ECM connectors. Connect the check harness special tool (MB992110) between the separated connectors. Then connect the oscilloscope probe to the check harness connector terminal No. 8 (crankshaft position sensor) and terminal No. 7 (exhaust camshaft position sensor).

- (5) Start the engine and run at idle.

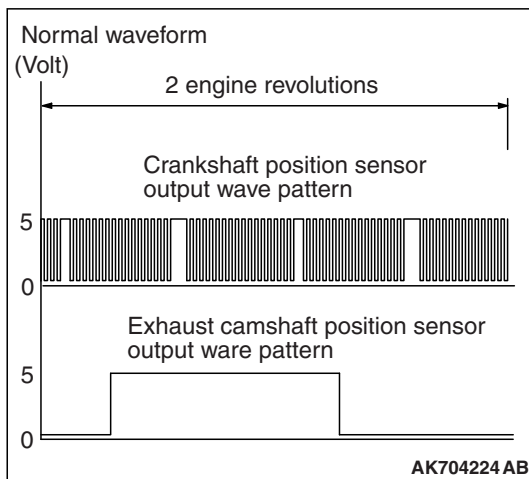

- (6) Check the waveform.
- The waveform should show a pattern similar to the illustration.
- (7) Turn the ignition switch to the "LOCK" (OFF) position.

Q: Is the waveform normal?

- YES** : Go to Step 2.
NO : Go to Step 3.

STEP 2. Check the trouble symptoms.

- (1) Carry out a test drive with the drive cycle pattern. Refer to Diagnostic Function –OBD-II Drive Cycle –Pattern 20 [P.13A-9](#).
- (2) Check the diagnostic trouble code (DTC).

Q: Is DTC P0017 set?

- YES** : Replace the ECM. When the ECM is replaced, register the ID code. Refer to GROUP 42B, ID Code Registration Necessity Judgment Table <Vehicles with KOS> [P.42B-11](#) or GROUP 42C, ID Codes Registration Judgment Table <Vehicles with WCM> [P.42C-9](#). Then go to Step 4.
- NO** : It can be assumed that this malfunction is intermittent. Refer to GROUP 00, How to Use Troubleshooting/ Inspection Service Points –How to Cope with Intermittent Malfunctions [P.00-15](#).

STEP 3. Check timing mark on the timing chain.

Q: Is timing chain in out of place?

- YES** : Repair it. Then go to Step 4.
- NO** : Check the following items, and repair or replace the defective items.
- a. Check the timing chain loose.
 - b. Check the exhaust variable valve timing sprocket tooth coming off.
- Then go to Step 4.

STEP 4. Test the OBD-II drive cycle.

- (1) Carry out a test drive with the drive cycle pattern. Refer to Diagnostic Function –OBD-II Drive Cycle –Pattern 20 [P.13A-9](#).
- (2) Check the diagnostic trouble code (DTC).

Q: Is DTC P0017 set?

- YES** : Retry the troubleshooting.
- NO** : The inspection is complete.

DTC P0031: Heated Oxygen Sensor (front) Heater Circuit Low

HEATED OXYGEN SENSOR (FRONT) HEATER CIRCUIT

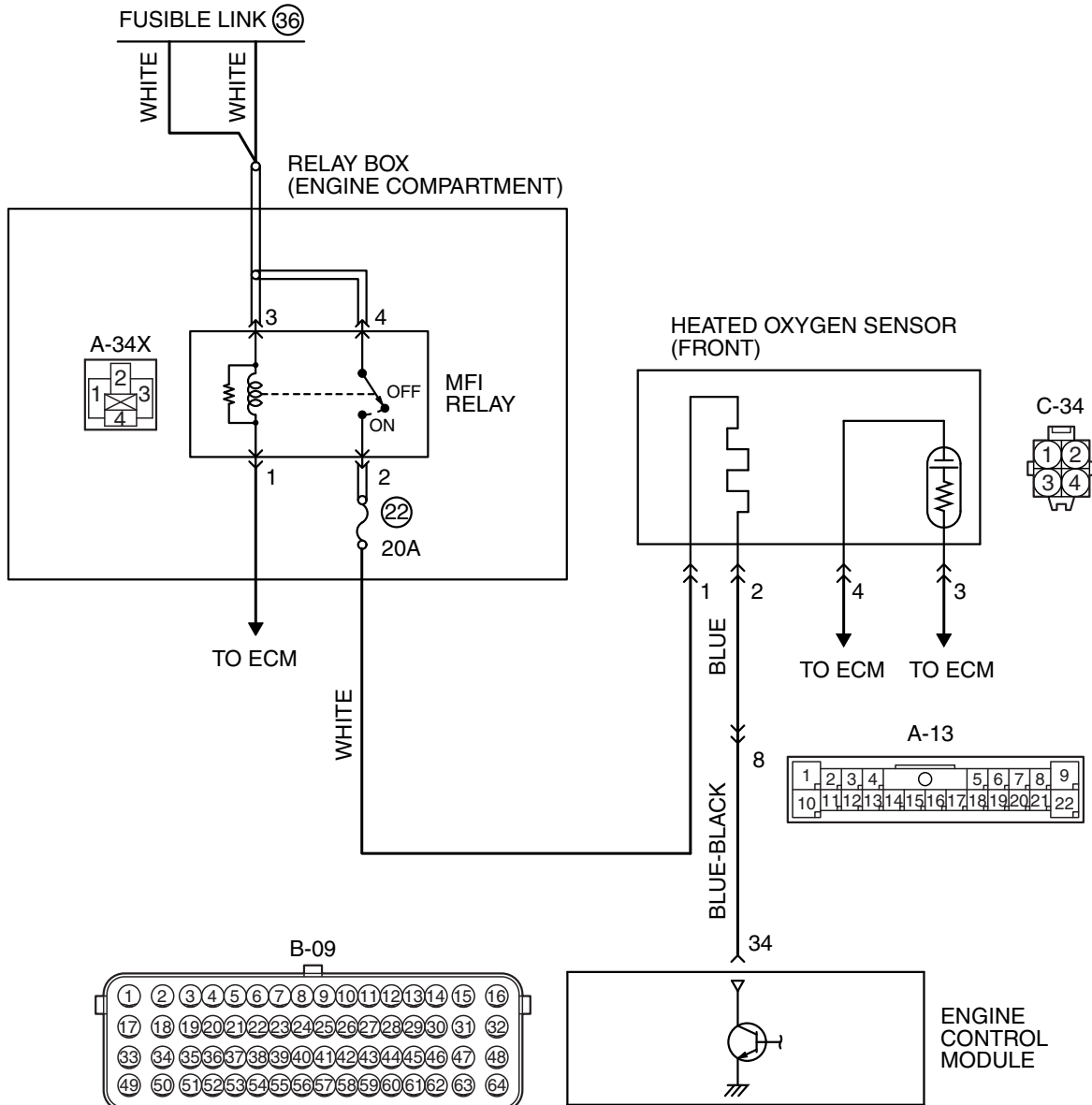

AK704225AB

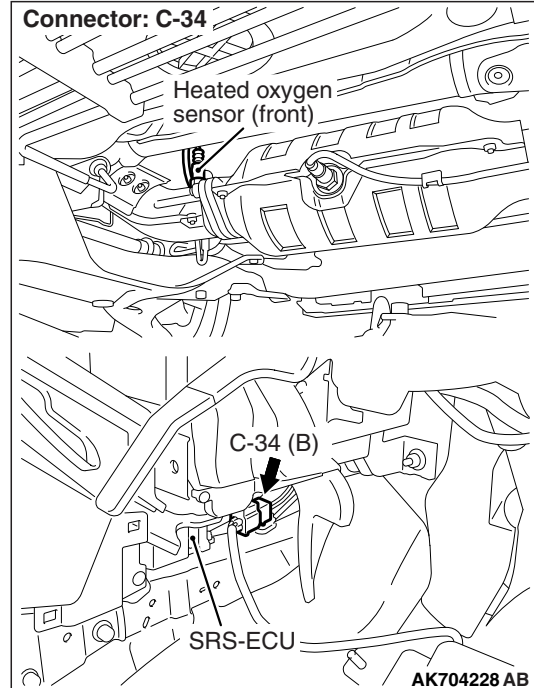
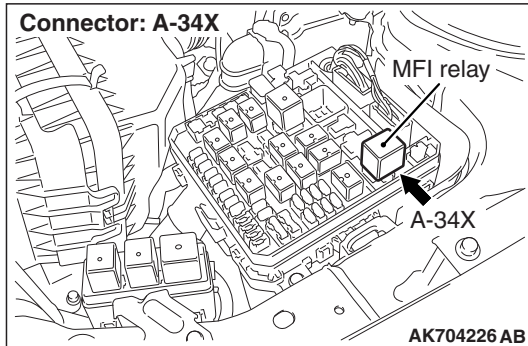
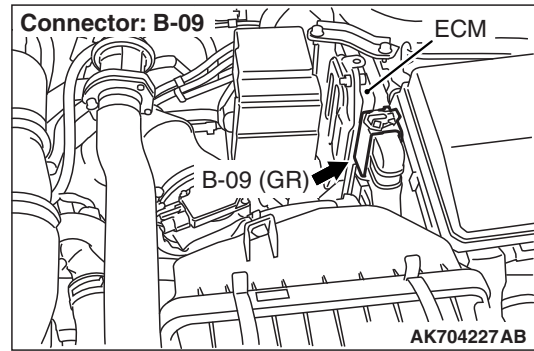
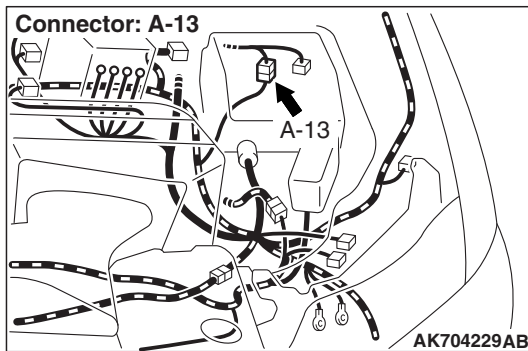

CIRCUIT OPERATION

- Power is supplied from the MFI relay (terminal No. 2) to the heated oxygen sensor (front) heater.
- The ECM (terminal No. 34) controls continuity to the heated oxygen sensor (front) heater by turning the power transistor in the ECM "ON" and "OFF".

TECHNICAL DESCRIPTION

- The ECM checks whether the heater current is within a specified range when the heater is energized.
- The ECM checks whether the heater voltage is within a specified range when the heater is not energized.

DESCRIPTIONS OF MONITOR METHODS

Heated oxygen sensor heater (front) current or voltage is out of specified range.

MONITOR EXECUTION

Continuous

MONITOR EXECUTION CONDITIONS (Other monitor and Sensor)

Other Monitor (There is no temporary DTC stored in memory for the item monitored below)

- Not applicable

Sensor (The sensor below is determined to be normal)

- Not applicable

DTC SET CONDITIONS

Logic Flow Chart

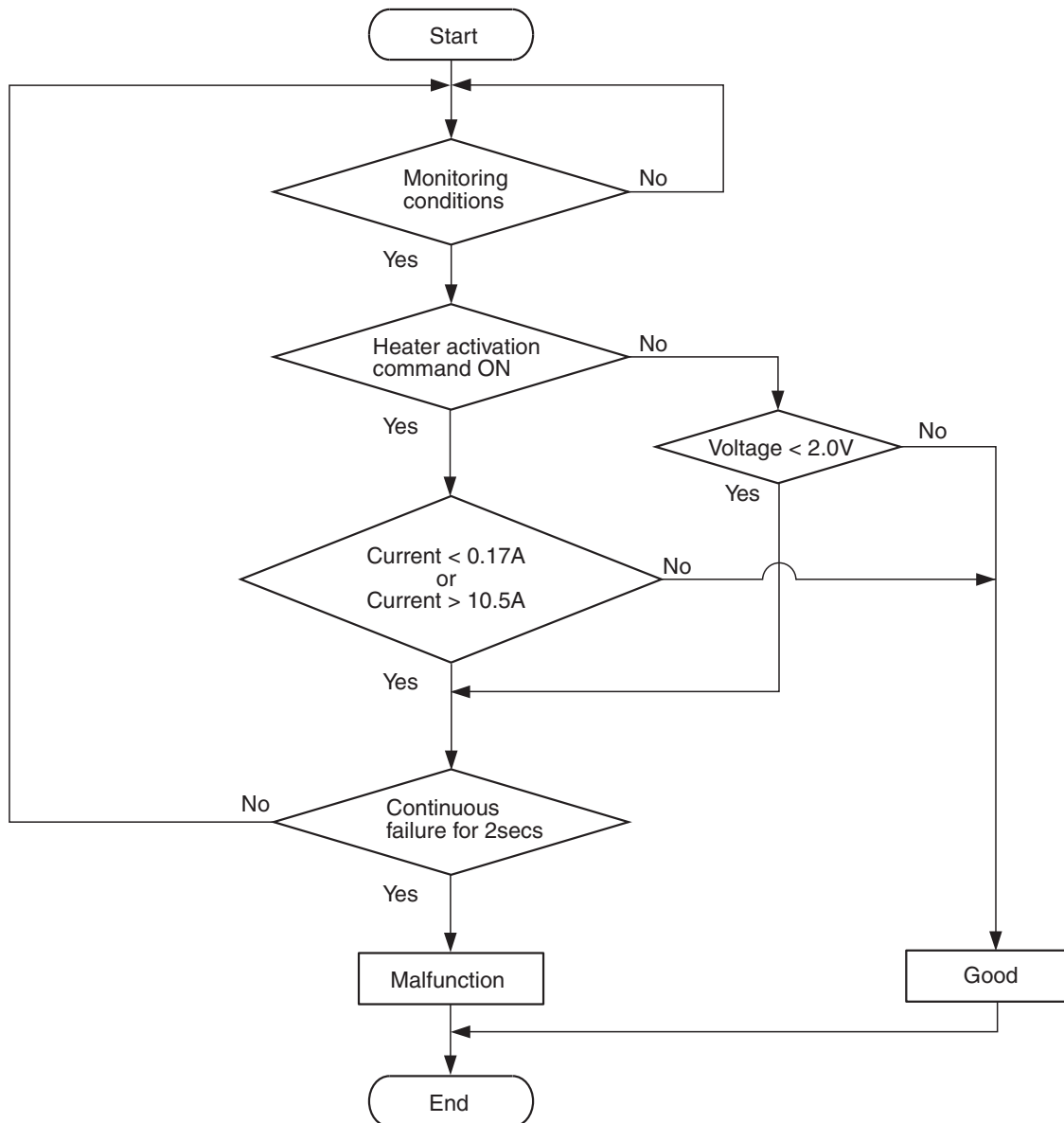

AK900352

Check Conditions

- More than 2 seconds have passed since the engine starting sequence was completed.
- While the heated oxygen sensor (front) heater is on.
- Battery positive voltage is between 11 and 16.5 volts.

Judgement Criterion

- The heated oxygen sensor (front) heater current has continued to be lower than 0.17 ampere for 2 seconds.

Check Conditions

- More than 2 seconds have passed since the engine starting sequence was completed.
- While the heated oxygen sensor (front) heater is off.
- Battery positive voltage is between 11 and 16.5 volts.

Judgement Criterion

- The heated oxygen sensor (front) heater voltage has continued to be lower than 2.0 volts for 2 seconds.

FAIL-SAFE AND BACKUP FUNCTION

- None

OBD-II DRIVE CYCLE PATTERN

Refer to Diagnostic Function –OBD-II Drive Cycle –
Pattern 2 [P.13A-9](#).

TROUBLESHOOTING HINTS (The most likely causes for this code to be set are:)

- Open or shorted heated oxygen sensor (front) heater circuit, harness damage or connector damage.
- Heated oxygen sensor (front) heater failed.
- ECM failed.

DIAGNOSIS

Required Special Tools:

- MB991658: Test Harness
- MB992110: Power Plant ECU Check Harness

STEP 1. Check harness connector C-34 at the heated oxygen sensor (front) for damage.

Q: Is the harness connector in good condition?

YES : Go to Step 2.

NO : Repair or replace it. Refer to GROUP 00E, Harness Connector Inspection [P.00E-2](#). Then go to Step 12.

STEP 2. Check the heated oxygen sensor (front).

- (1) Disconnect heated oxygen sensor (front) connector C-34 and connect test harness special tool, MB991658, to the connector on the heated oxygen sensor (front) side.
- (2) Measure the resistance between heated oxygen sensor connector terminal No. 1 and terminal No. 2.

Standard value: 4.5 –8.0 Ω [at 20° C (68° F)]

Q: Is the measured resistance between 4.5 and 8.0 Ω [at 20° C (68° F)]?

YES : Go to Step 3.

NO : Replace the heated oxygen sensor (front). Then go to Step 12.

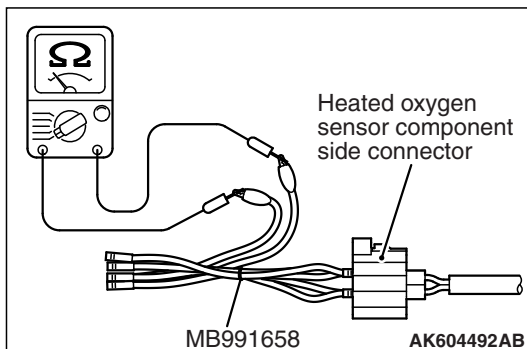

STEP 3. Measure the power supply voltage at heated oxygen sensor (front) harness side connector C-34.

- (1) Disconnect the connector C-34 and measure at the harness side.
- (2) Turn the ignition switch to the "ON" position.
- (3) Measure the voltage between terminal No. 1 and ground.
 - Voltage should be battery positive voltage.
- (4) Turn the ignition switch to the "LOCK" (OFF) position.

Q: Is battery positive voltage (approximately 12 volts) present?

YES : Go to Step 5.

NO : Go to Step 4.

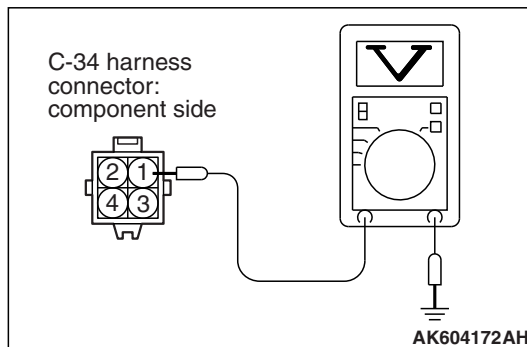

STEP 4. Check harness connector A-34X at the MFI relay for damage.

Q: Is the harness connector in good condition?

YES : Repair harness wire between MFI relay connector A-34X (terminal No. 2) and heated oxygen sensor (front) connector C-34 (terminal No. 1) because of open circuit or short circuit to ground. Then go to Step 12.

NO : Repair or replace it. Refer to GROUP 00E, Harness Connector Inspection P.00E-2. Then go to Step 12.

STEP 5. Measure the power supply voltage at ECM connector B-09 by using power plant ECU check harness special tool MB992110.

- (1) Disconnect all ECM connectors. Connect the power plant ECU check harness special tool MB992110 between the separated connectors.
- (2) Turn the ignition switch to the "ON" position.

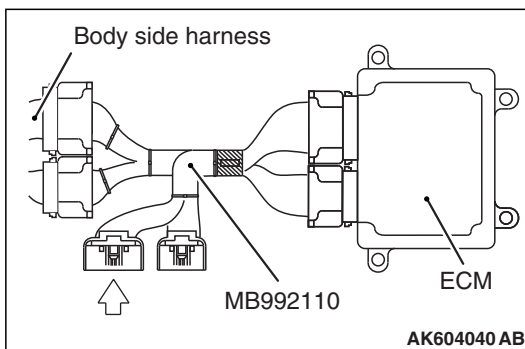

- (3) Measure the voltage between terminal No. 34 and ground.
 - Voltage should be battery positive voltage.
- (4) Turn the ignition switch to the "LOCK" (OFF) position.

Q: Is battery positive voltage (approximately 12 volts) present?

YES : Go to Step 8.

NO : Go to Step 6.

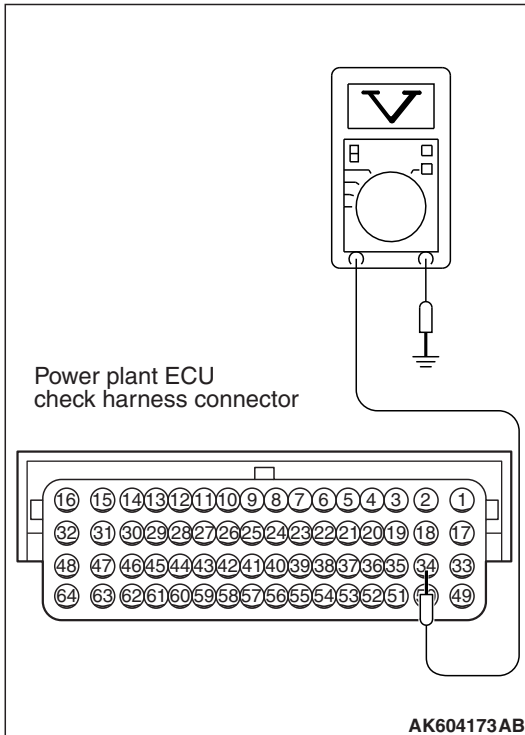

STEP 6. Check harness connector B-09 at ECM for damage.

Q: Is the harness connector in good condition?

YES : Go to Step 7.

NO : Repair or replace it. Refer to GROUP 00E, Harness Connector Inspection [P.00E-2](#). Then go to Step 12.

STEP 7. Check for open circuit and short circuit to ground between heated oxygen sensor (front) connector C-34 (terminal No. 2) and ECM connector B-09 (terminal No. 34).

NOTE: Check harness after checking intermediate connector A-13. If intermediate connector is damaged, repair or replace it. Refer to GROUP 00E, Harness Connector Inspection [P.00E-2](#). Then go to Step 12.

Q: Is the harness wire in good condition?

YES : Replace the ECM. When the ECM is replaced, register the ID code. Refer to GROUP 42B, ID Code Registration Necessity Judgment Table <Vehicles with KOS> [P.42B-11](#) or GROUP 42C, ID Codes Registration Judgment Table <Vehicles with WCM> [P.42C-9](#). Then go to Step 12.

NO : Repair it. Then go to Step 12.

STEP 8. Check harness connector B-09 at ECM for damage.

Q: Is the harness connector in good condition?

YES : Go to Step 9.

NO : Repair or replace it. Refer to GROUP 00E, Harness Connector Inspection [P.00E-2](#). Then go to Step 12.

STEP 9. Check for harness damage between MFI relay connector A-34X (terminal No. 2) and heated oxygen sensor (front) connector C-34 (terminal No. 1).

Q: Is the harness wire in good condition?

YES : Go to Step 10.

NO : Repair it. Then go to Step 12.

STEP 10. Check for harness damage between heated oxygen sensor (front) connector C-34 (terminal No. 2) and ECM connector B-09 (terminal No. 34).

NOTE: Check harness after checking intermediate connector A-13. If intermediate connector is damaged, repair or replace it. Refer to GROUP 00E, Harness Connector Inspection [P.00E-2](#). Then go to Step 12.

Q: Is the harness wire in good condition?

YES : Go to Step 11.

NO : Repair it. Then go to Step 12.

STEP 11. Check the trouble symptoms.

- (1) Carry out a test drive with the drive cycle pattern. Refer to Diagnostic Function –OBD-II Drive Cycle –Pattern 2 [P.13A-9](#).
- (2) Check the diagnostic trouble code (DTC).

Q: Is DTC P0031 set?

YES : Replace the ECM. When the ECM is replaced, register the ID code. Refer to GROUP 42B, ID Code Registration Necessity Judgment Table <Vehicles with KOS> [P.42B-11](#) or GROUP 42C, ID Codes Registration Judgment Table <Vehicles with WCM> [P.42C-9](#). Then go to Step 12.

NO : It can be assumed that this malfunction is intermittent. Refer to GROUP 00, How to Use Troubleshooting/Inspection Service Points –How to Cope with Intermittent Malfunctions [P.00-15](#).

STEP 12. Test the OBD-II drive cycle.

- (1) Carry out a test drive with the drive cycle pattern. Refer to Diagnostic Function –OBD-II Drive Cycle –Pattern 2 [P.13A-9](#).
- (2) Check the diagnostic trouble code (DTC).

Q: Is DTC P0031 set?

YES : Retry the troubleshooting.

NO : The inspection is complete.

DTC P0032: Heated Oxygen Sensor (front) Heater Circuit High

HEATED OXYGEN SENSOR (FRONT) HEATER CIRCUIT

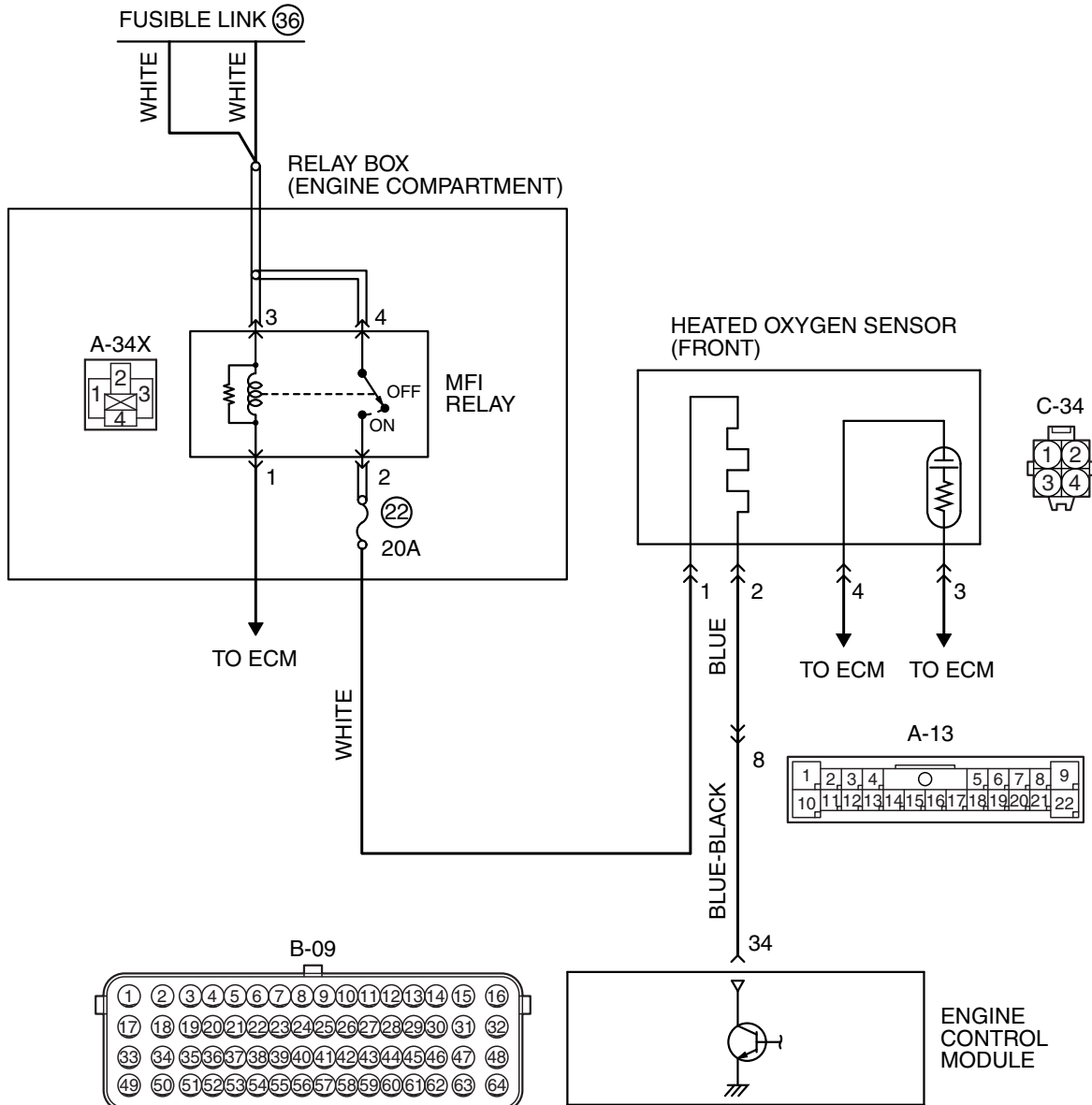

AK704225AB

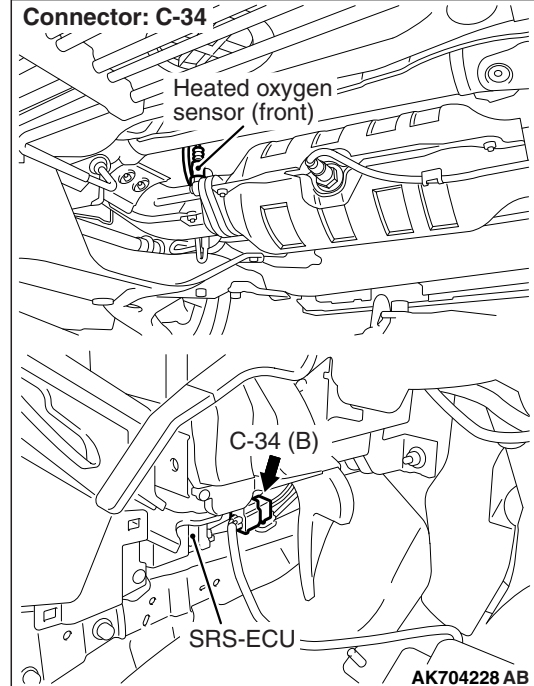
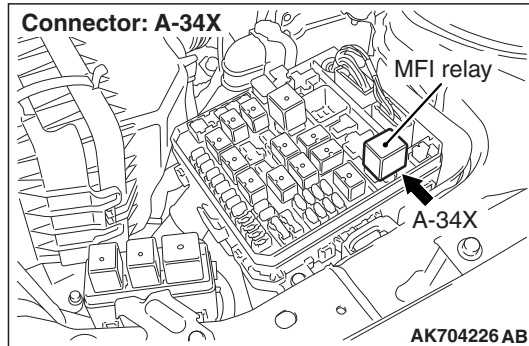
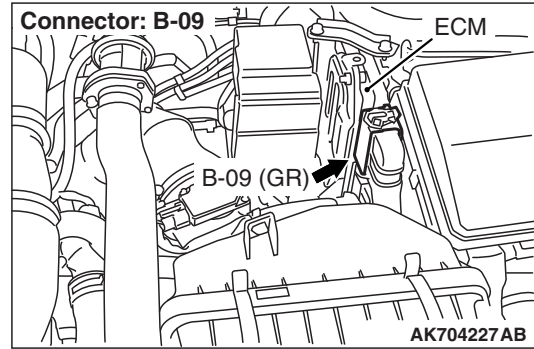
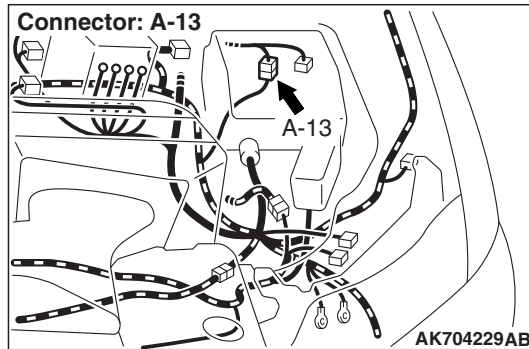

CIRCUIT OPERATION

- Power is supplied from the MFI relay (terminal No. 2) to the heated oxygen sensor (front) heater.
- The ECM (terminal No. 34) controls continuity to the heated oxygen sensor (front) heater by turning the power transistor in the ECM "ON" and "OFF".

TECHNICAL DESCRIPTION

- The ECM checks whether the heater current is within a specified range when the heater is energized.

DESCRIPTIONS OF MONITOR METHODS

Heated oxygen sensor heater (front) current is out of specified range.

MONITOR EXECUTION

Continuous

MONITOR EXECUTION CONDITIONS (Other monitor and Sensor)

Other Monitor (There is no temporary DTC stored in memory for the item monitored below)

- Not applicable

Sensor (The sensor below is determined to be normal)

- Not applicable

DTC SET CONDITIONS

Logic Flow Chart

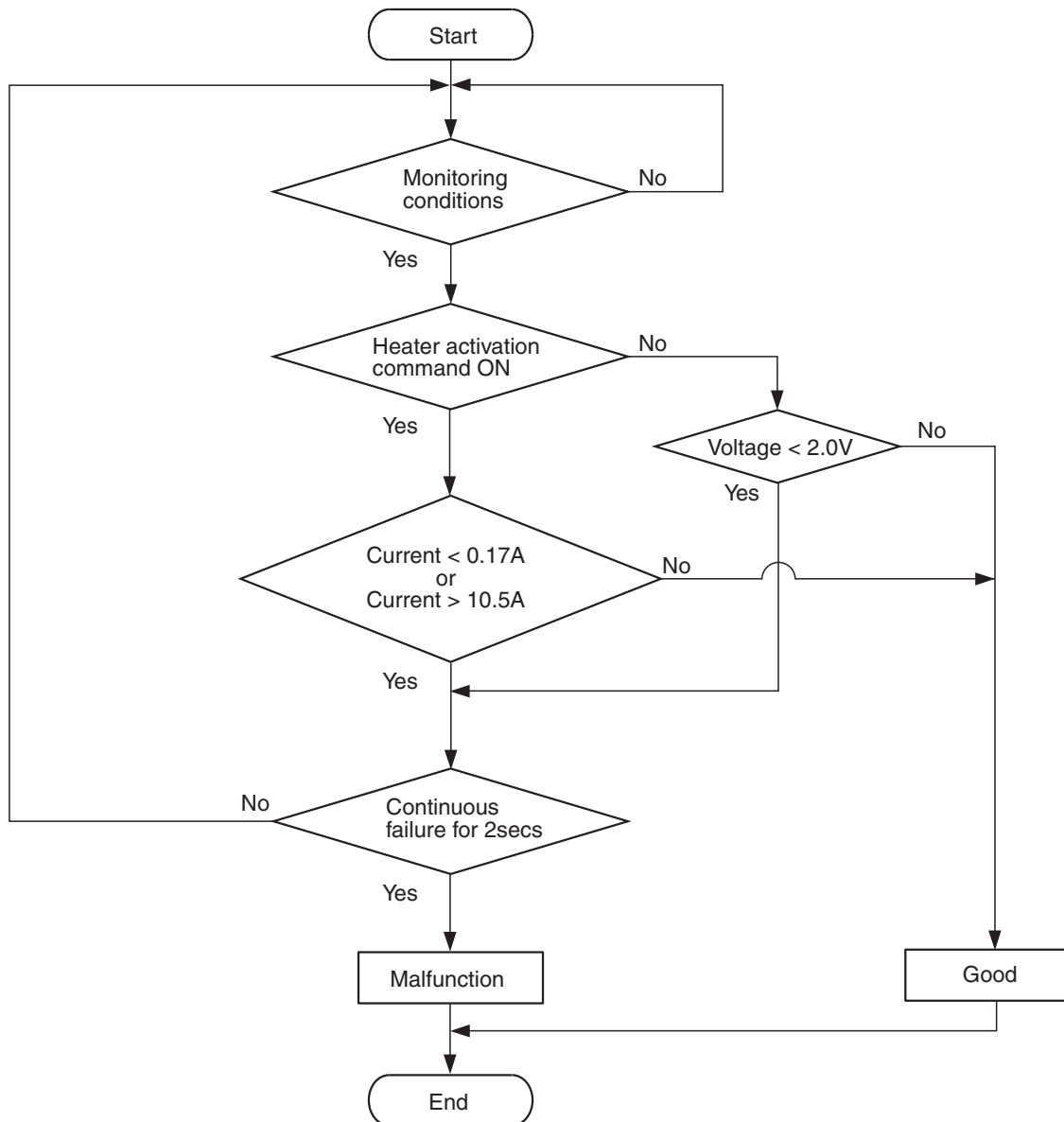

AK900352

Check Conditions

- More than 2 seconds have passed since the engine starting sequence was completed.
- While the heated oxygen sensor (front) heater is on.
- Battery positive voltage is between 11 and 16.5 volts.

Judgement Criterion

- The heated oxygen sensor (front) heater current has continued to be higher than 10.5 ampere for 2 seconds.

FAIL-SAFE AND BACKUP FUNCTION

- None

OBD-II DRIVE CYCLE PATTERN

Refer to Diagnostic Function –OBD-II Drive Cycle – Pattern 2 [P.13A-9](#).

TROUBLESHOOTING HINTS (The most likely causes for this code to be set are:)

- Heated oxygen sensor (front) heater failed.
- ECM failed.

DIAGNOSIS

Required Special Tool:

- MB991658: Test Harness

STEP 1. Check the heated oxygen sensor (front).

- (1) Disconnect heated oxygen sensor (front) connector C-34 and connect test harness special tool, MB991658, to the connector on the heated oxygen sensor (front) side.
- (2) Measure the resistance between heated oxygen sensor connector terminal No. 1 and terminal No. 2.

Standard value: 4.5 –8.0 Ω [at 20° C (68° F)]

Q: Is the measured resistance between 4.5 and 8.0 Ω [at 20° C (68° F)]?

YES : Go to Step 2.

NO : Replace the heated oxygen sensor (front). Then go to Step 3.

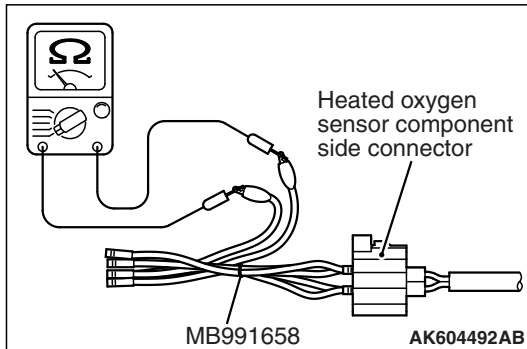

STEP 2. Check the trouble symptoms.

- (1) Carry out a test drive with the drive cycle pattern. Refer to Diagnostic Function –OBD-II Drive Cycle –Pattern 2 [P.13A-9](#).
- (2) Check the diagnostic trouble code (DTC).

Q: Is DTC P0032 set?

YES : Replace the ECM. When the ECM is replaced, register the ID code. Refer to GROUP 42B, ID Code Registration Necessity Judgment Table <Vehicles with KOS> [P.42B-11](#) or GROUP 42C, ID Codes Registration Judgment Table <Vehicles with WCM> [P.42C-9](#). Then go to Step 3.

NO : It can be assumed that this malfunction is intermittent. Refer to GROUP 00, How to Use Troubleshooting/Inspection Service Points –How to Cope with Intermittent Malfunctions [P.00-15](#).

STEP 3. Test the OBD-II drive cycle.

- (1) Carry out a test drive with the drive cycle pattern. Refer to Diagnostic Function –OBD-II Drive Cycle –Pattern 2 [P.13A-9](#).
- (2) Check the diagnostic trouble code (DTC).

Q: Is DTC P0032 set?

YES : Retry the troubleshooting.

NO : The inspection is complete.

DTC P0037: Heated Oxygen Sensor (rear) Heater Circuit Low

HEATED OXYGEN SENSOR (REAR) HEATER CIRCUIT

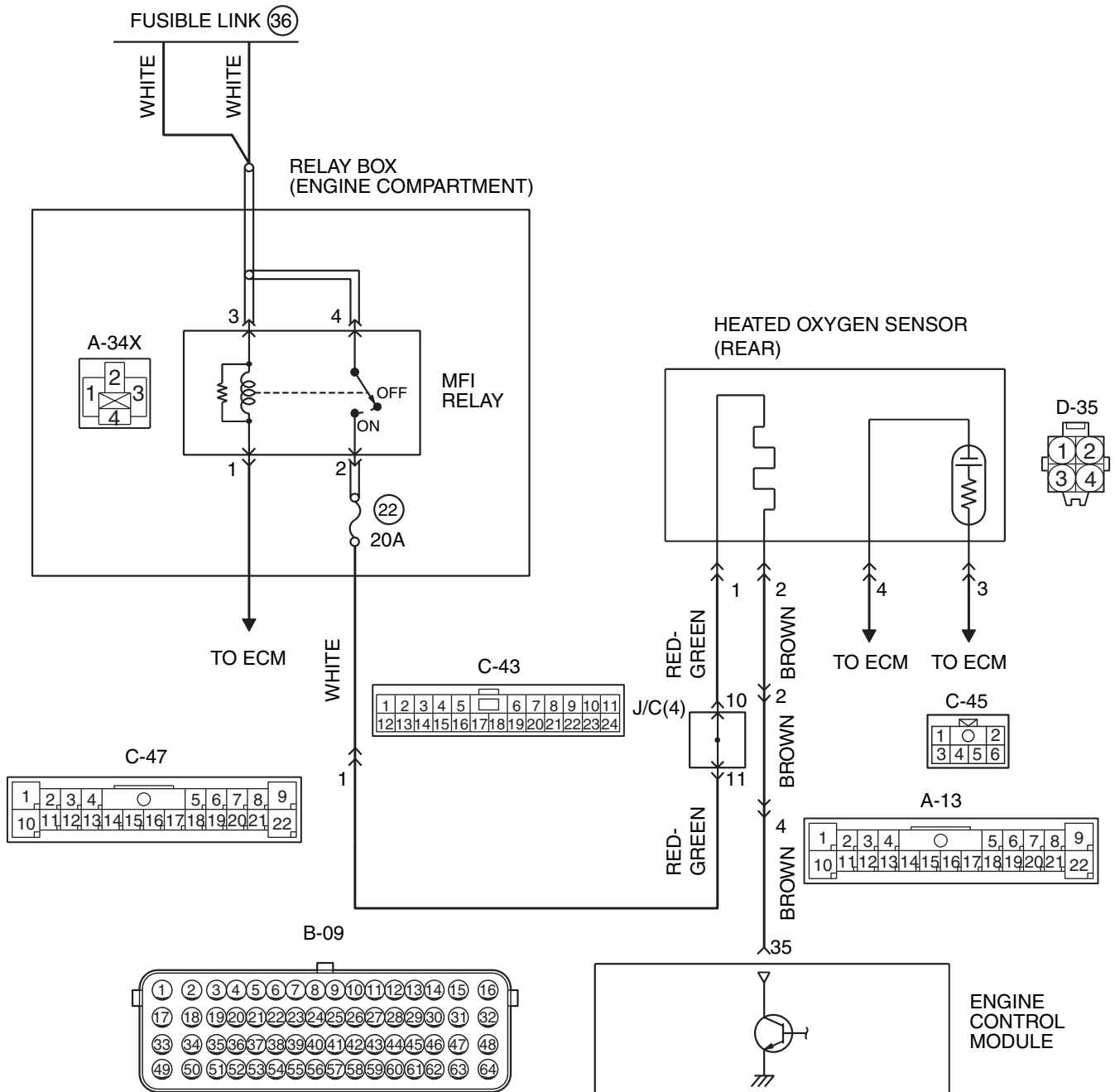

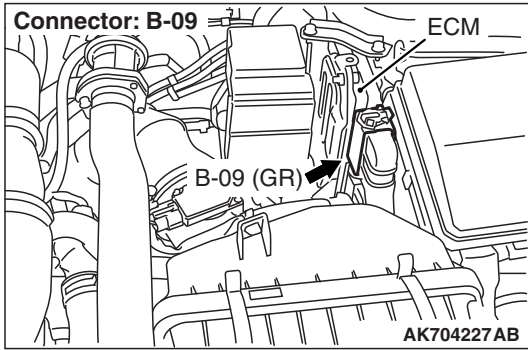
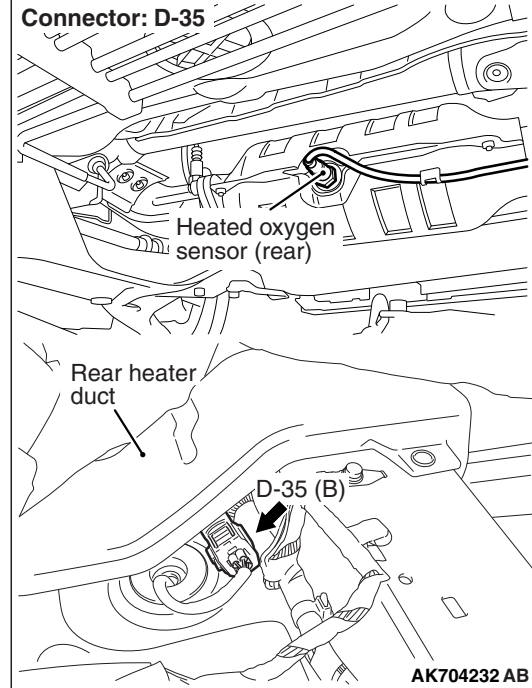
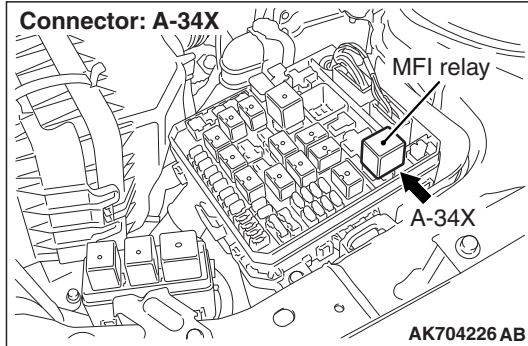
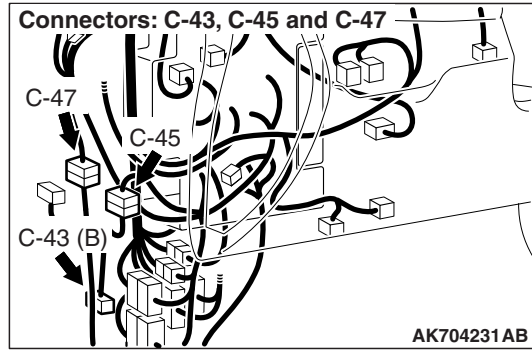
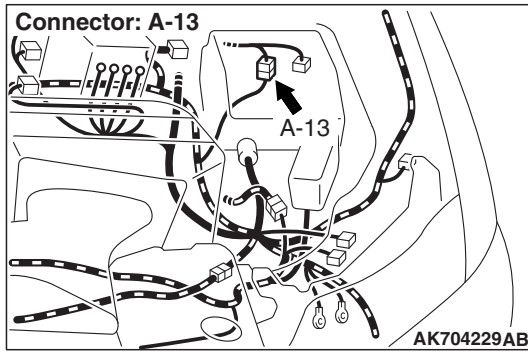

CIRCUIT OPERATION

- Power is supplied from the MFI relay (terminal No. 2) to the heated oxygen sensor (rear) heater.
- The ECM (terminal No. 35) controls continuity to the heated oxygen sensor (rear) heater by turning the power transistor in the ECM "ON" and "OFF".

TECHNICAL DESCRIPTION

- The ECM checks whether the heater current is within a specified range when the heater is energized.
- The ECM checks whether the heater voltage is within a specified range when the heater is not energized.

DESCRIPTIONS OF MONITOR METHODS

Heated oxygen sensor (rear) heater current or voltage is out of specified range.

MONITOR EXECUTION

Continuous

MONITOR EXECUTION CONDITIONS (Other monitor and Sensor)

Other Monitor (There is no temporary DTC stored in memory for the item monitored below)

- Not applicable

Sensor (The sensor below is determined to be normal)

- Not applicable

DTC SET CONDITIONS

Logic Flow Chart

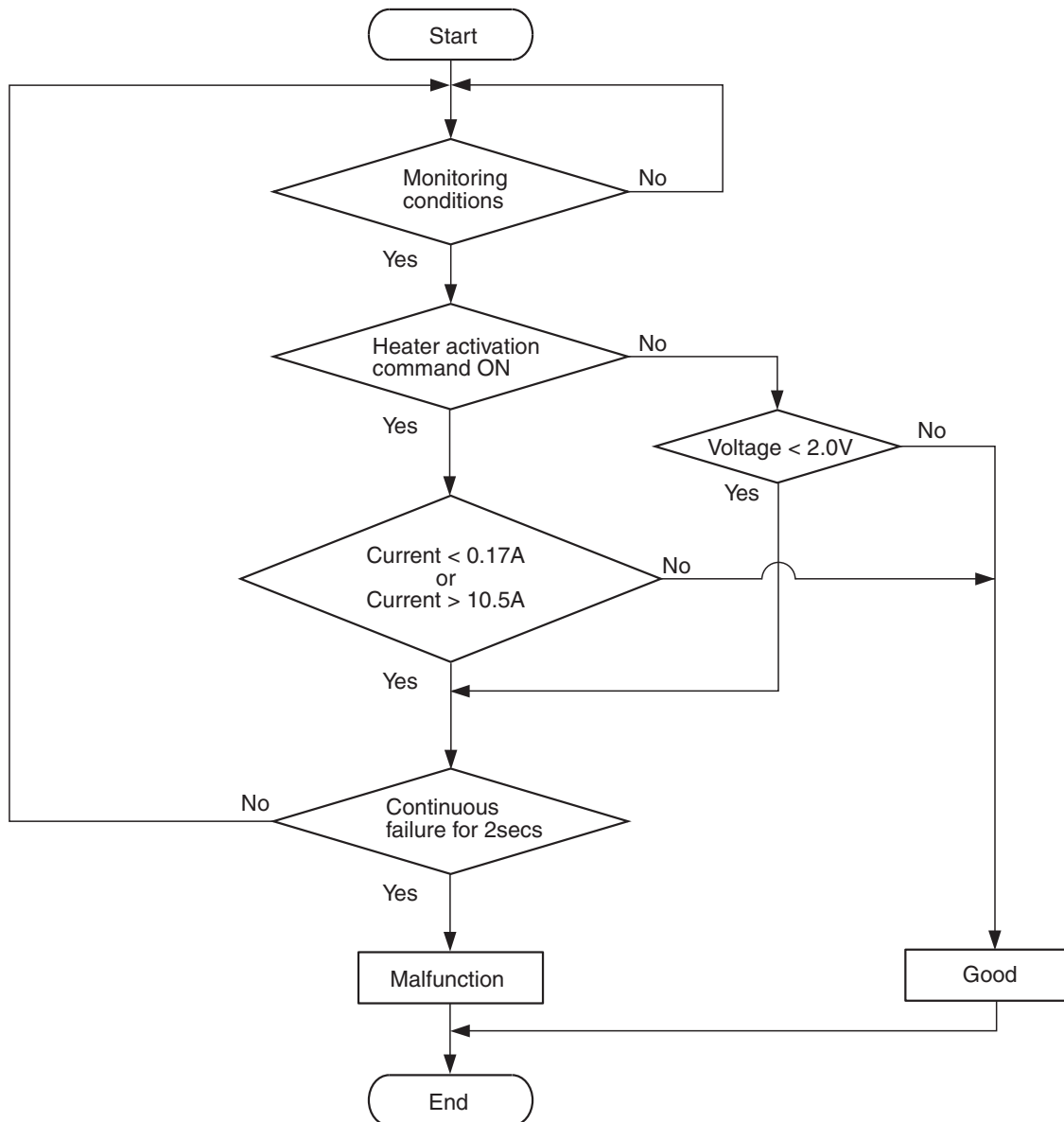

AK900352

Check Conditions

- More than 2 seconds have passed since the engine starting sequence was completed.
- While the heated oxygen sensor (rear) heater is on.
- Battery positive voltage is between 11 and 16.5 volts.

Judgement Criterion

- The heated oxygen sensor (rear) heater current has continued to be lower than 0.17 ampere for 2 seconds.

Check Conditions

- More than 2 seconds have passed since the engine starting sequence was completed.
- While the heated oxygen sensor (rear) heater is off.
- Battery positive voltage is between 11 and 16.5 volts.

Judgement Criterion

- The heated oxygen sensor (rear) heater voltage has continued to be lower than 2.0 volts for 2 seconds.

FAIL-SAFE AND BACKUP FUNCTION

- None

OBD-II DRIVE CYCLE PATTERN

Refer to Diagnostic Function –OBD-II Drive Cycle –
Pattern 2 [P.13A-9](#).

TROUBLESHOOTING HINTS (The most likely causes for this code to be set are:)

- Open or shorted heated oxygen sensor (rear) heater circuit, or harness damage.
- Heated oxygen sensor (rear) heater failed.
- Connector damage.
- ECM failed.

DIAGNOSIS**Required Special Tools:**

- MB991658: Test Harness
- MB992110: Power Plant ECU Check Harness

STEP 1. Check harness connector D-35 at the heated oxygen sensor (rear) for damage.**Q: Is the harness connector in good condition?**

YES : Go to Step 2.

NO : Repair or replace it. Refer to GROUP 00E, Harness Connector Inspection [P.00E-2](#). Then go to Step 12.

STEP 2. Check the heated oxygen sensor (rear).

- (1) Disconnect heated oxygen sensor (rear) connector D-35 and connect test harness special tool, MB991658, to the connector on the heated oxygen sensor (rear) side.
- (2) Measure the resistance between heated oxygen sensor connector terminal No. 1 and terminal No. 2.

Standard value: 4.5 –8.0 Ω [at 20° C (68° F)]

Q: Is the measured resistance between 4.5 and 8.0 Ω [at 20° C (68° F)]?

YES : Go to Step 3.

NO : Replace the heated oxygen sensor (rear). Then go to Step 12.

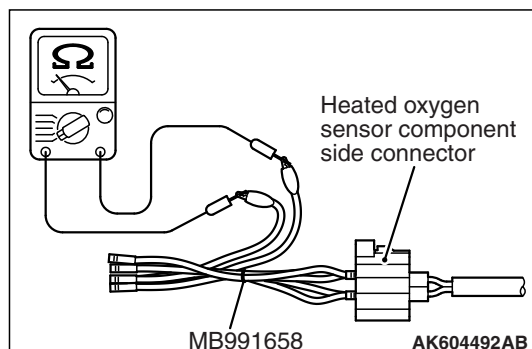
**STEP 3. Measure the power supply voltage at heated oxygen sensor (rear) harness side connector D-35.**

- (1) Disconnect the connector D-35 and measure at the harness side.
- (2) Turn the ignition switch to the "ON" position.
- (3) Measure the voltage between terminal No. 1 and ground.
 - Voltage should be battery positive voltage.
- (4) Turn the ignition switch to the "LOCK" (OFF) position.

Q: Is battery positive voltage (approximately 12 volts) present?

YES : Go to Step 5.

NO : Go to Step 4.

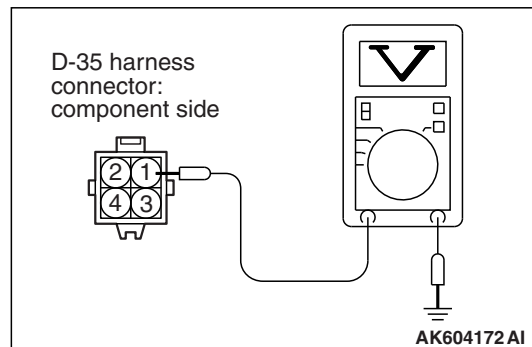

STEP 4. Check harness connector A-34X at the MFI relay for damage.

Q: Is the harness connector in good condition?

YES : Check harness connectors C-43 and C-47 at intermediate connectors for damage, and repair or replace as required. Refer to GROUP 00E, Harness Connector Inspection P.00E-2. If intermediate connectors are in good condition, repair harness wire between MFI relay connector A-34X (terminal No. 2) and heated oxygen sensor (rear) connector D-35 (terminal No. 1) because of open circuit or short circuit to ground. Then go to Step 12.

NO : Repair or replace it. Refer to GROUP 00E, Harness Connector Inspection P.00E-2. Then go to Step 12.

STEP 5. Measure the power supply voltage at ECM connector B-09 by using power plant ECU check harness special tool MB992110.

- (1) Disconnect all ECM connectors. Connect the power plant ECU check harness special tool MB992110 between the separated connectors.
- (2) Turn the ignition switch to the "ON" position.

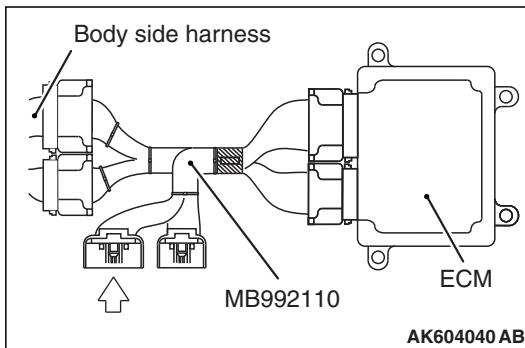

- (3) Measure the voltage between terminal No. 35 and ground.
 - Voltage should be battery positive voltage.
- (4) Turn the ignition switch to the "LOCK" (OFF) position.

Q: Is battery positive voltage (approximately 12 volts) present?

YES : Go to Step 8.

NO : Go to Step 6.

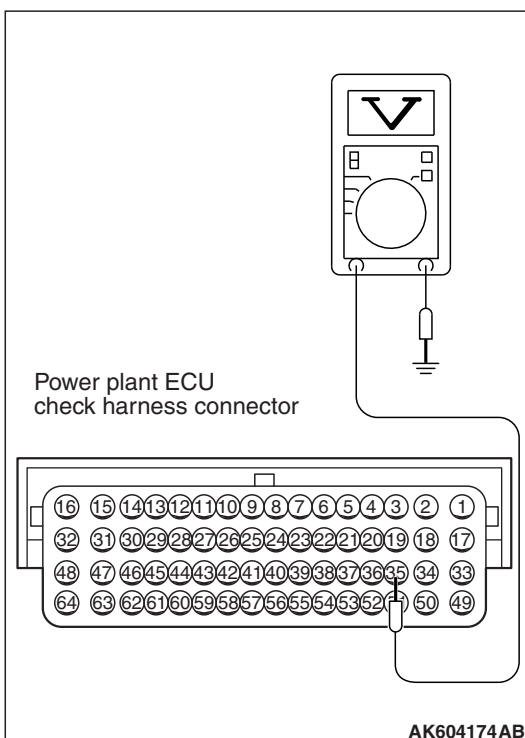

STEP 6. Check harness connector B-09 at ECM for damage.

Q: Is the harness connector in good condition?

YES : Go to Step 7.

NO : Repair or replace it. Refer to GROUP 00E, Harness Connector Inspection [P.00E-2](#). Then go to Step 12.

STEP 7. Check for open circuit and short circuit to ground between heated oxygen sensor (rear) connector D-35 (terminal No. 2) and ECM connector B-09 (terminal No. 35).

NOTE: Check harness after checking intermediate connectors A-13 and C-45. If intermediate connectors are damaged, repair or replace them. Refer to GROUP 00E, Harness Connector Inspection [P.00E-2](#). Then go to Step 12.

Q: Is the harness wire in good condition?

YES : Replace the ECM. When the ECM is replaced, register the ID code. Refer to GROUP 42B, ID Code Registration Necessity Judgment Table <Vehicles with KOS> [P.42B-11](#) or GROUP 42C, ID Codes Registration Judgment Table <Vehicles with WCM> [P.42C-9](#). Then go to Step 12.

NO : Repair it. Then go to Step 12.

STEP 8. Check harness connector B-09 at ECM for damage.

Q: Is the harness connector in good condition?

YES : Go to Step 9.

NO : Repair or replace it. Refer to GROUP 00E, Harness Connector Inspection [P.00E-2](#). Then go to Step 12.

STEP 9. Check for harness damage between MFI relay connector A-34X (terminal No. 2) and heated oxygen sensor (rear) connector D-35 (terminal No. 1).

NOTE: Check harness after checking intermediate connectors C-43 and C-47. If intermediate connectors are damaged, repair or replace them. Refer to GROUP 00E, Harness Connector Inspection [P.00E-2](#). Then go to Step 12.

Q: Is the harness wire in good condition?

YES : Go to Step 10.

NO : Repair it. Then go to Step 12.

STEP 10. Check for harness damage between heated oxygen sensor (rear) connector D-35 (terminal No. 2) and ECM connector B-09 (terminal No. 35).

NOTE: Check harness after checking intermediate connectors A-13 and C-45. If intermediate connectors are damaged, repair or replace them. Refer to GROUP 00E, Harness Connector Inspection P.00E-2. Then go to Step 12.

Q: Is the harness wire in good condition?

YES : Go to Step 11.

NO : Repair it. Then go to Step 12.

STEP 11. Check the trouble symptoms.

(1) Carry out a test drive with the drive cycle pattern. Refer to Diagnostic Function –OBD-II Drive Cycle –Pattern 2 P.13A-9.

(2) Check the diagnostic trouble code (DTC).

Q: Is DTC P0037 set?

YES : Replace the ECM. When the ECM is replaced, register the ID code. Refer to GROUP 42B, ID Code Registration Necessity Judgment Table <Vehicles with KOS> P.42B-11 or GROUP 42C, ID Codes Registration Judgment Table <Vehicles with WCM> P.42C-9. Then go to Step 12.

NO : It can be assumed that this malfunction is intermittent. Refer to GROUP 00, How to Use Troubleshooting/Inspection Service Points –How to Cope with Intermittent Malfunctions P.00-15.

STEP 12. Test the OBD-II drive cycle.

(1) Carry out a test drive with the drive cycle pattern. Refer to Diagnostic Function –OBD-II Drive Cycle –Pattern 2 P.13A-9.

(2) Check the diagnostic trouble code (DTC).

Q: Is DTC P0037 set?

YES : Retry the troubleshooting.

NO : The inspection is complete.

DTC P0038: Heated Oxygen Sensor (rear) Heater Circuit High

HEATED OXYGEN SENSOR (REAR) HEATER CIRCUIT

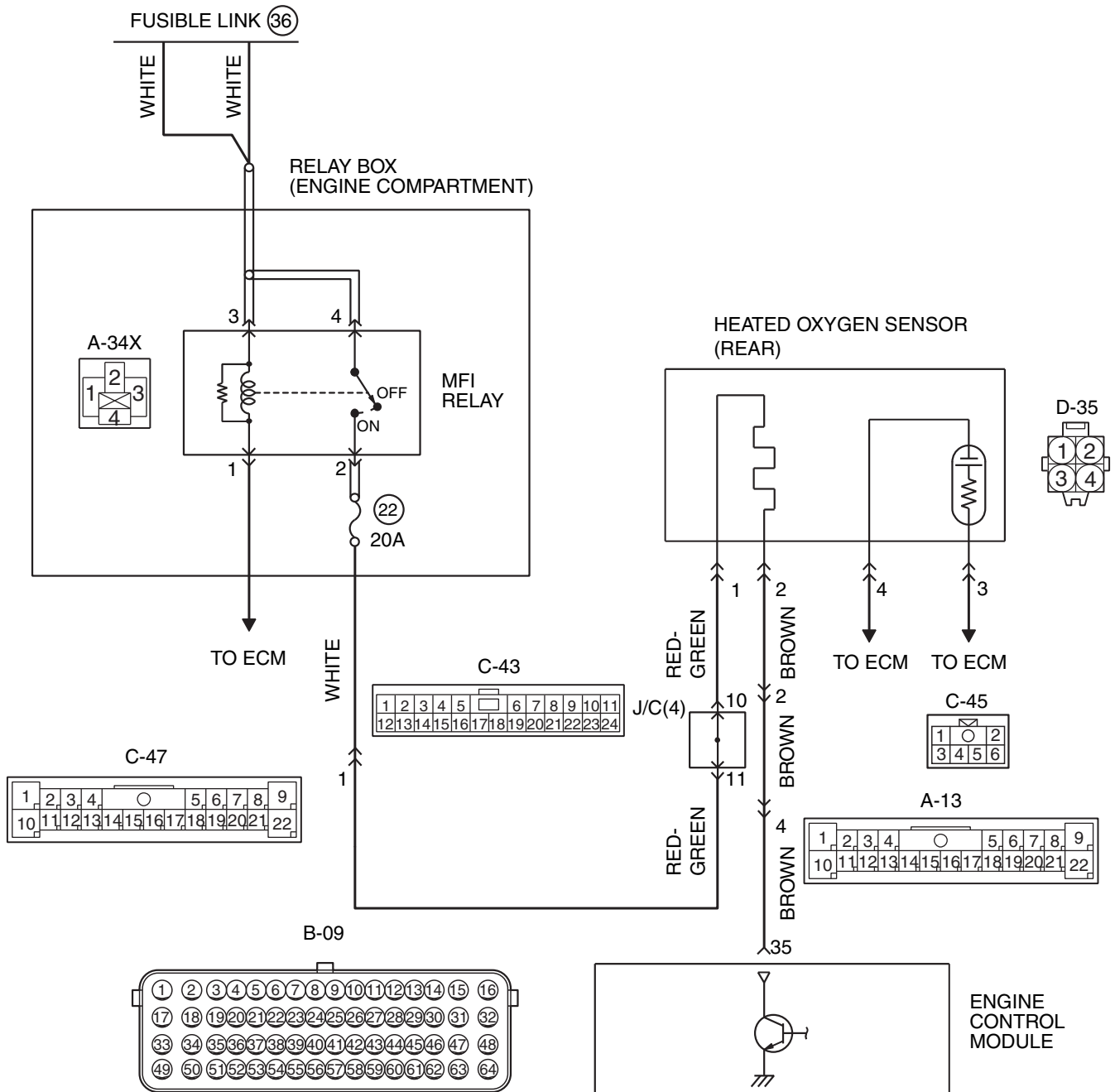

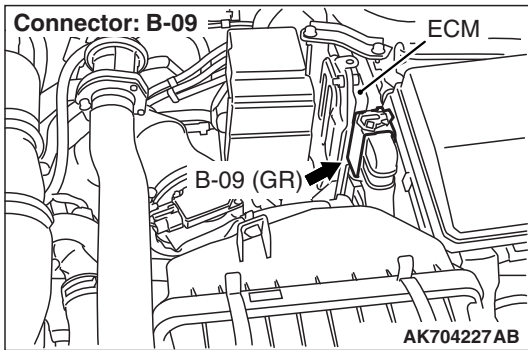
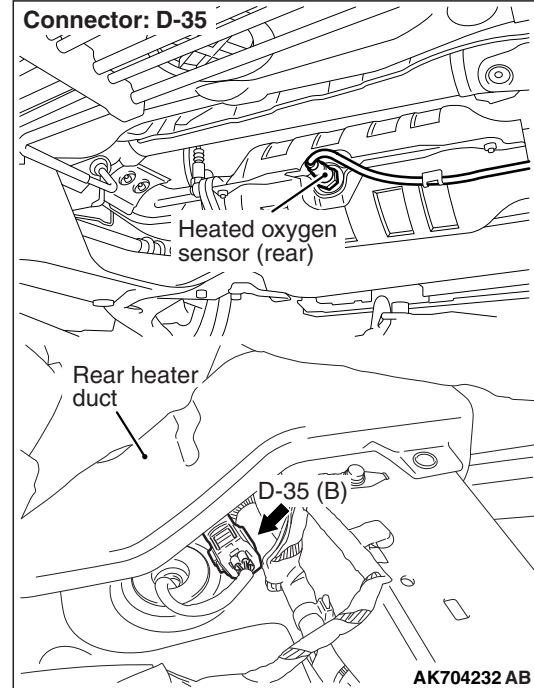
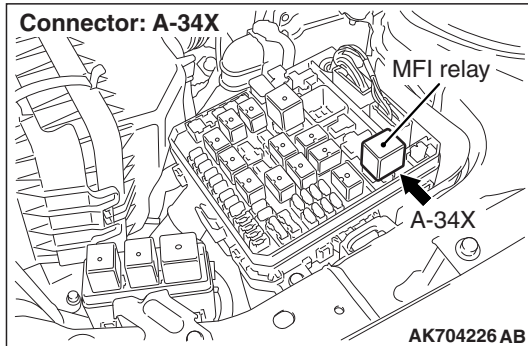
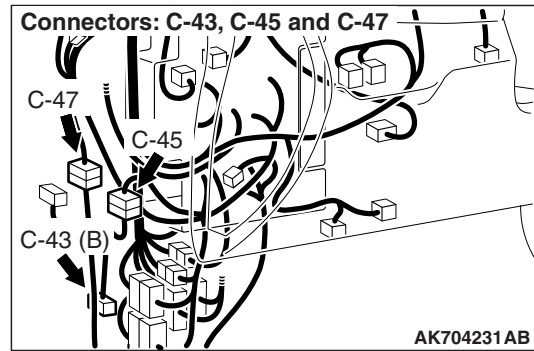
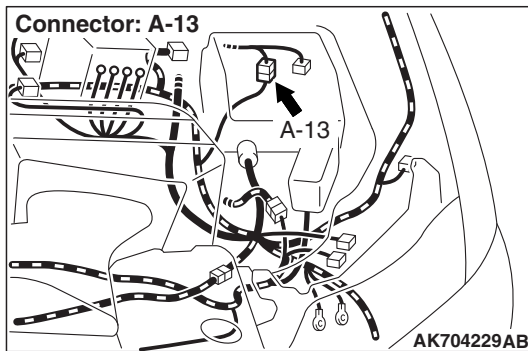

CIRCUIT OPERATION

- Power is supplied from the MFI relay (terminal No. 2) to the heated oxygen sensor (rear) heater.
- The ECM (terminal No. 35) controls continuity to the heated oxygen sensor (rear) heater by turning the power transistor in the ECM "ON" and "OFF".

TECHNICAL DESCRIPTION

- The ECM checks whether the heater current is within a specified range when the heater is energized.

DESCRIPTIONS OF MONITOR METHODS

Heated oxygen sensor heater (rear) current is out of specified range.

MONITOR EXECUTION

Continuous

MONITOR EXECUTION CONDITIONS (Other monitor and Sensor)

Other Monitor (There is no temporary DTC stored in memory for the item monitored below)

- Not applicable

Sensor (The sensor below is determined to be normal)

- Not applicable

DTC SET CONDITIONS

Logic Flow Chart

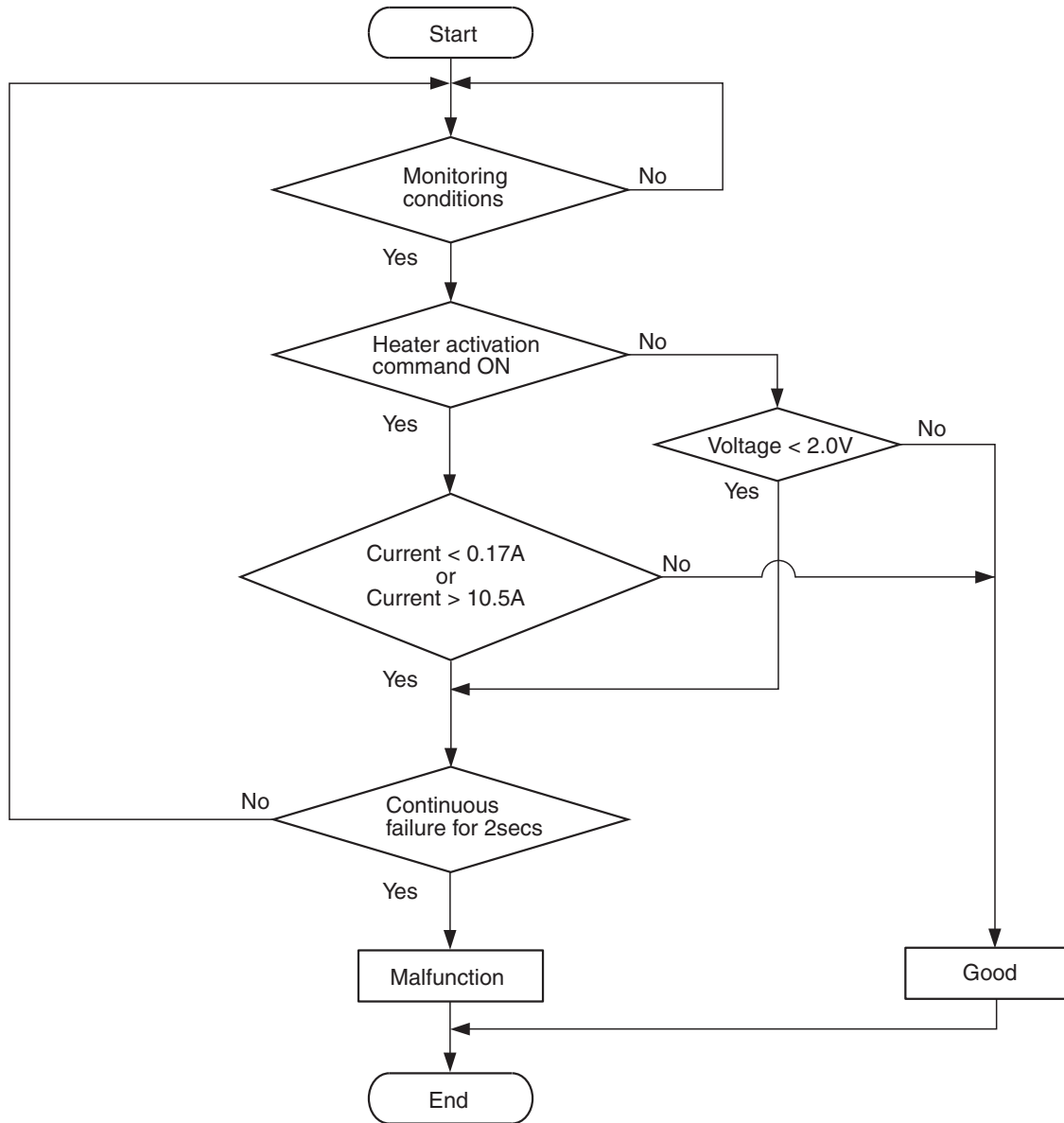

AK900352

Check Conditions

- More than 2 seconds have passed since the engine starting sequence was completed.
- While the heated oxygen sensor (rear) heater is on.
- Battery positive voltage is between 11 and 16.5 volts.

Judgement Criterion

- The heated oxygen sensor (rear) heater current has continued to be higher than 10.5 ampere for 2 seconds.

FAIL-SAFE AND BACKUP FUNCTION

- None

OBD-II DRIVE CYCLE PATTERN

Refer to Diagnostic Function –OBD-II Drive Cycle – Pattern 2 [P.13A-9](#).

TROUBLESHOOTING HINTS (The most likely causes for this code to be set are:)

- Heated oxygen sensor (rear) failed.
- ECM failed.

DIAGNOSIS

Required Special Tool:

- MB991658: Test Harness

STEP 1. Check the heated oxygen sensor (rear).

- (1) Disconnect heated oxygen sensor (rear) connector D-35 and connect test harness special tool, MB991658, to the connector on the heated oxygen sensor (rear) side.
- (2) Measure the resistance between heated oxygen sensor connector terminal No. 1 and terminal No. 2.

Standard value: 4.5 –8.0 Ω [at 20° C (68° F)]

Q: Is the measured resistance between 4.5 and 8.0 Ω [at 20° C (68° F)]?

YES : Go to Step 2.

NO : Replace the heated oxygen sensor (rear). Then go to Step 3.

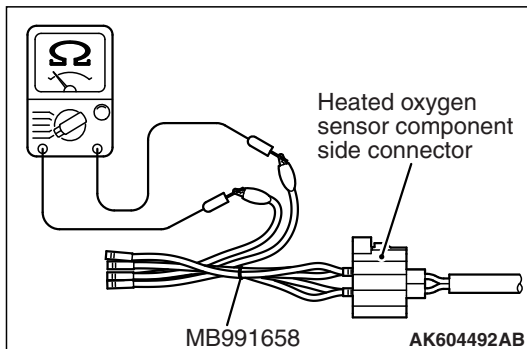

STEP 2. Check the trouble symptoms.

- (1) Carry out a test drive with the drive cycle pattern. Refer to Diagnostic Function –OBD-II Drive Cycle –Pattern 2 [P.13A-9](#).
- (2) Check the diagnostic trouble code (DTC).

Q: Is DTC P0038 set?

YES : Replace the ECM. When the ECM is replaced, register the ID code. Refer to GROUP 42B, ID Code Registration Necessity Judgment Table <Vehicles with KOS> [P.42B-11](#) or GROUP 42C, ID Codes Registration Judgment Table <Vehicles with WCM> [P.42C-9](#). Then go to Step 3.

NO : It can be assumed that this malfunction is intermittent. Refer to GROUP 00, How to Use Troubleshooting/Inspection Service Points –How to Cope with Intermittent Malfunctions [P.00-15](#).

STEP 3. Test the OBD-II drive cycle.

- (1) Carry out a test drive with the drive cycle pattern. Refer to Diagnostic Function –OBD-II Drive Cycle –Pattern 2 [P.13A-9](#).
- (2) Check the diagnostic trouble code (DTC).

Q: Is DTC P0038 set?

YES : Retry the troubleshooting.

NO : The inspection is complete.

DTC P0069: Abnormal Correlation Between Manifold Absolute Pressure Sensor And Barometric Pressure Sensor

TECHNICAL DESCRIPTION

- The ECM detects abnormality in the sensor by comparing the manifold absolute pressure sensor output with the barometric pressure sensor output.

DESCRIPTIONS OF MONITOR METHODS

The ECM compares the manifold absolute pressure sensor output with the barometric pressure sensor output while the engine control relay is in "ON" position after the ignition switch is in "LOCK" (OFF) position. When the difference exceeds the specified value between them, the ECM determines whether the manifold absolute pressure sensor / the barometric pressure sensor has malfunction or not.

MONITOR EXECUTION

Continuous

**MONITOR EXECUTION CONDITIONS
(Other monitor and Sensor)**

Other Monitor (There is no temporary DTC stored in memory for the item monitored below)

- Not applicable

Sensor (The sensor below is determined to be normal)

- Mass airflow sensor
- Engine coolant temperature sensor
- Intake air temperature sensor
- Barometric pressure sensor
- Throttle position sensor
- Manifold absolute pressure sensor

DTC SET CONDITIONS

Logic Flow Chart

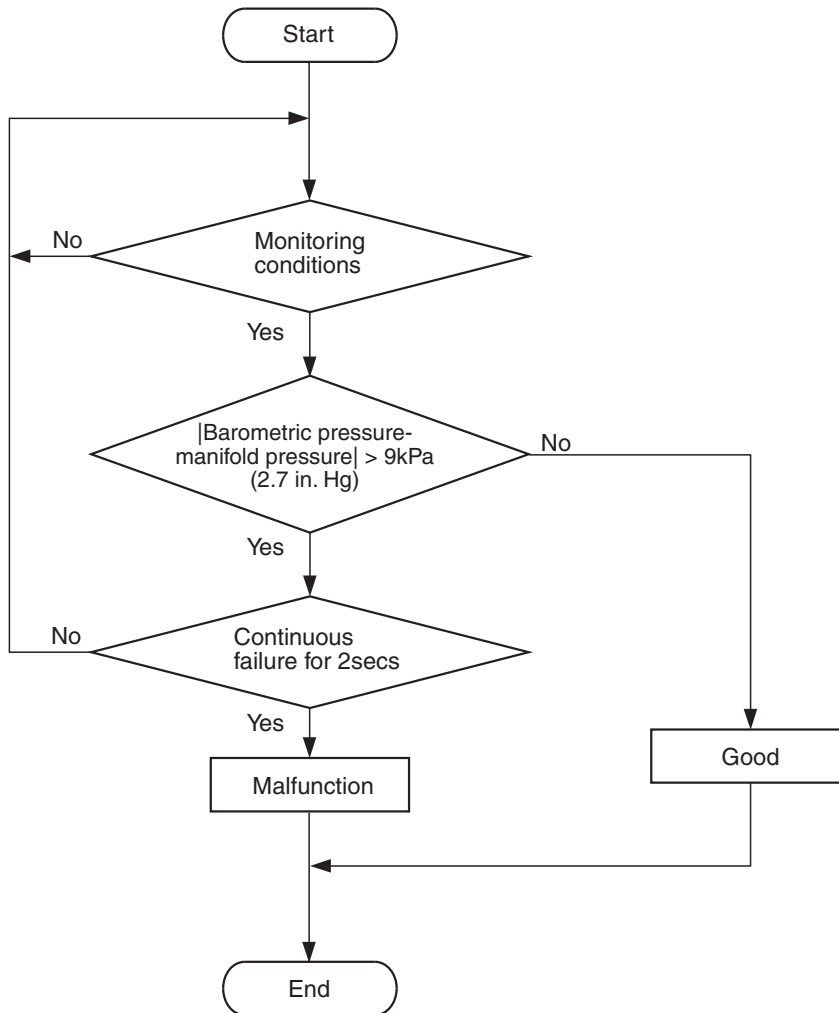

AK704095

Check Conditions

- Ignition switch is in "LOCK" (OFF) position.
- After 2 seconds pass from the time when the engine is stopped.
- Engine coolant temperature is higher than 0° C (32° F).

Judgement Criterion

- Difference between manifold absolute pressure sensor output and barometric pressure sensor output is more than 9 kPa (2.7 in.Hg) for 2 seconds.

FAIL-SAFE AND BACKUP FUNCTION

- None

OBD-II DRIVE CYCLE PATTERN

None.

TROUBLESHOOTING HINTS (The most likely causes for this code to be set are:)

- Manifold absolute pressure sensor failed.
- Barometric pressure sensor failed.
- ECM failed.

DIAGNOSIS**Required Special Tools**

- MB991958: Scan tool (M.U.T.-III Sub Assembly)
 - MB991824: V.C.I.
 - MB991827: USB Cable
 - MB991910: Main Harness A

STEP 1. Using scan tool MB991958, read the diagnostic trouble code (DTC).

⚠ CAUTION

To prevent damage to scan tool MB991958, always turn the ignition switch to the "LOCK" (OFF) position before connecting or disconnecting scan tool MB991958.

- (1) Connect scan tool MB991958 to the data link connector.
- (2) Turn the ignition switch to the "ON" position.
- (3) Set scan tool MB991958, read the DTC.
- (4) Turn the ignition switch to the "LOCK" (OFF) position.

Q: Is the diagnostic trouble code other than P0069 set?

YES : Refer to, Diagnostic Trouble Code Chart [P.13A-48](#).

NO : Go to Step 2.

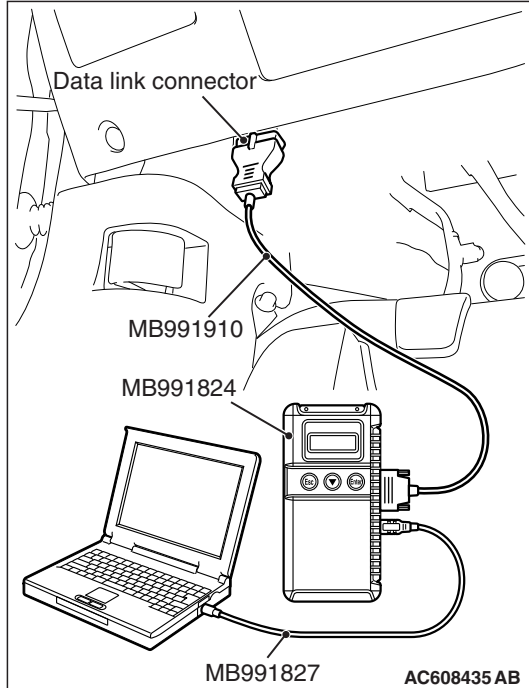

STEP 2. Using scan tool MB991958, check data list item 8: Manifold Absolute Pressure Sensor.

- (1) Turn the ignition switch to the "ON" position.
- (2) Set scan tool MB991958 to the data reading mode for item 8, Manifold Absolute Pressure Sensor.
 - When altitude is 0 m (0 foot), 101 kPa (29.8 in.Hg).
 - When altitude is 600 m (1,969 feet), 95 kPa (28.1 in.Hg).
 - When altitude is 1,200 m (3,937 feet), 88 kPa (26.0 in.Hg).
 - When altitude is 1,800 m (5,906 feet), 81 kPa (23.9 in.Hg).
- (3) Start the engine.
 - When the engine is idling, 16 –36 kPa (4.7 –10.6 in.Hg).
 - When the engine is suddenly revved, manifold absolute pressure varies.
- (4) Turn the ignition switch to the "LOCK" (OFF) position.

Q: Is the sensor operating properly?

YES : Go to Step 3.

NO : Refer to, DTC P0106 –Manifold Absolute Pressure Circuit Range/Performance Problem [P.13A-145](#), DTC P0107 –Manifold Absolute Pressure Circuit Low Input [P.13A-154](#), DTC P0108 –Manifold Absolute Pressure Circuit High Input [P.13A-162](#).

STEP 3. Using scan tool MB991958, read the diagnostic trouble code (DTC).

- (1) Turn the ignition switch to the "ON" position.
- (2) Erase the DTC.
- (3) Start the engine.
- (4) Turn the ignition switch to "LOCK" (OFF) position and then wait 2 seconds.
- (5) Turn the ignition switch to the "ON" position.
- (6) Set scan tool MB991958, read the DTC.
- (7) Turn the ignition switch to the "LOCK" (OFF) position.

Q: Is DTC P0069 set?

YES : Replace the ECM. When the ECM is replaced, register the ID code. Refer to GROUP 42B, ID Code Registration Necessity Judgment Table <Vehicles with KOS> [P.42B-11](#) or GROUP 42C, ID Codes Registration Judgment Table <Vehicles with WCM> [P.42C-9](#). Then go to Step 4.

NO : It can be assumed that this malfunction is intermittent. Refer to GROUP 00, How to Use Troubleshooting/Inspection Service Points –How to Cope with Intermittent Malfunctions [P.00-15](#).

STEP 4. Using scan tool MB991958, read the diagnostic trouble code (DTC).

- (1) Turn the ignition switch to the "ON" position.
- (2) Erase the DTC.
- (3) Start the engine.
- (4) Turn the ignition switch to "LOCK" (OFF) position and then wait 2 seconds.
- (5) Turn the ignition switch to the "ON" position.
- (6) Set scan tool MB991958, read the DTC.
- (7) Turn the ignition switch to the "LOCK" (OFF) position.

Q: Is DTC P0069 set?

YES : Retry the troubleshooting.

NO : The inspection is complete.

DTC P0096: Intake Air Temperature Circuit Range/Performance Problem (sensor 2)

INTAKE AIR TEMPERATURE SENSOR 2 CIRCUIT

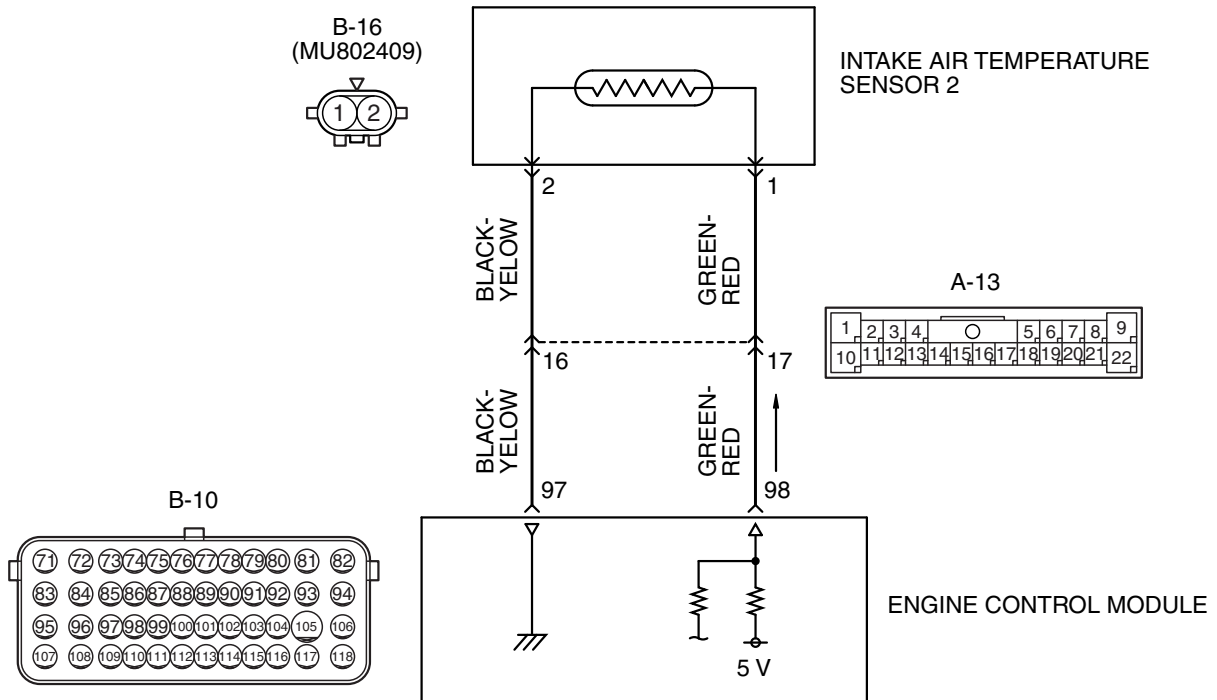

AK704399AB

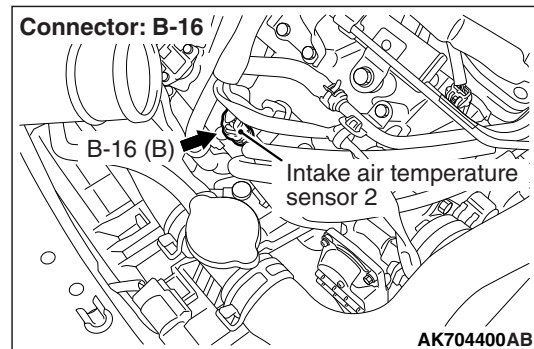
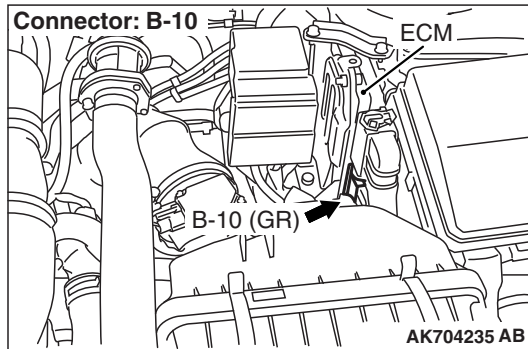

CIRCUIT OPERATION

- Approximately 5 volts are applied to the intake air temperature sensor 2 output terminal (terminal No. 1) from the ECM (terminal No. 98) via the resistor in the ECM. The ground terminal (terminal No. 2) is grounded with ECM (terminal No. 97).
- The intake air temperature sensor 2 is a negative temperature coefficient type of resistor. When the intake air temperature rises, the resistance decreases.
- The intake air temperature sensor 2 output voltage increases when the resistance increases and decreases when the resistance decreases.

TECHNICAL DESCRIPTION

- The intake air temperature sensor 2 converts the intake air temperature to a voltage.
- The ECM checks whether this voltage is within a specified range.

DESCRIPTIONS OF MONITOR METHODS

Intake air temperature sensor 2 output voltage does not change when specified go/stop operations are repeated.

MONITOR EXECUTION

Continuous

MONITOR EXECUTION CONDITIONS (Other monitor and Sensor)

Other Monitor (There is no temporary DTC stored in memory for the item monitored below)

- Not applicable

Sensor (The sensor below is determined to be normal)

- Engine coolant temperature sensor

DTC SET CONDITIONS

Logic Flow Chart

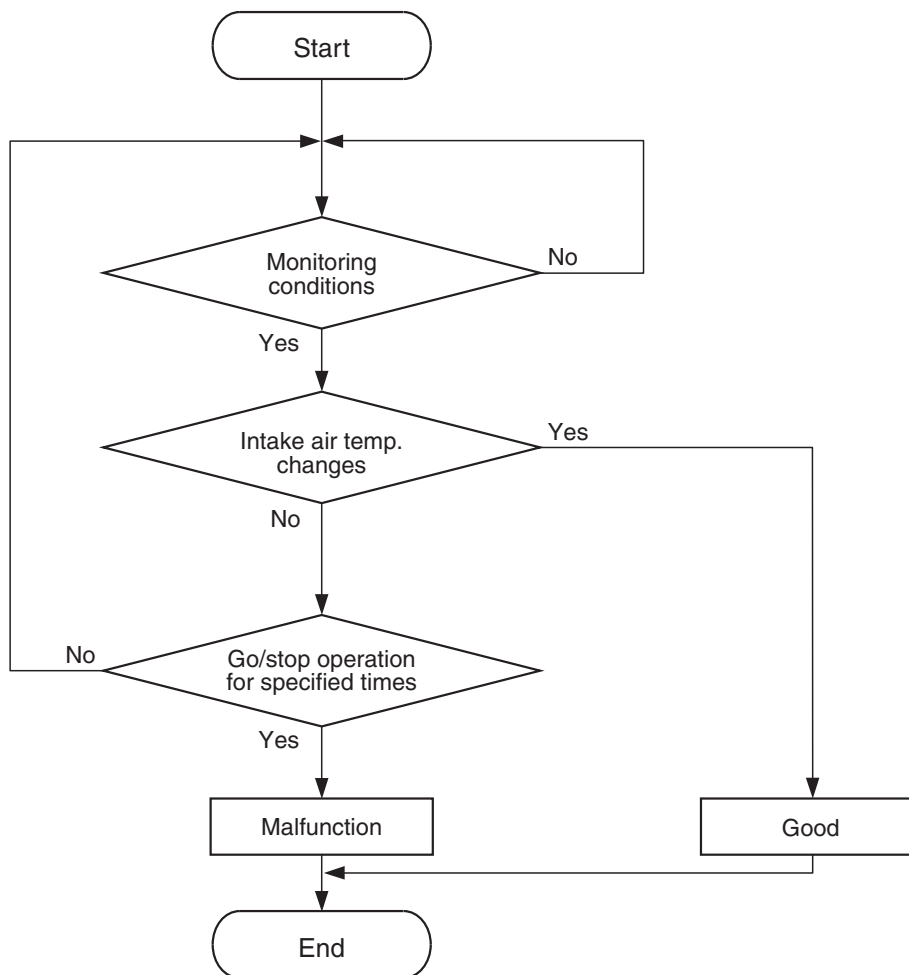

AK604314

Check Conditions

- Engine coolant temperature is higher than 76° C (169° F).
- Repeat 2 or more times: drive^{*1}, stop^{*2}.
Drive^{*1}: vehicle speed higher than 50 km/h (31 mph) lasting a total of 60 seconds or more.
Stop^{*2}: vehicle speed lower than 1.5 km/h (1.0 mph) lasting 30 seconds or more.

Judgement Criterion

- Changes in the intake air temperature is lower than 1° C (1.8° F).

FAIL-SAFE AND BACKUP FUNCTION

- Control as if the intake air temperature in the intake manifold is 25 °C.

OBD-II DRIVE CYCLE PATTERN

Refer to Diagnostic Function –OBD-II Drive Cycle – Pattern 7 [P.13A-9](#).

TROUBLESHOOTING HINTS (The most likely causes for this code to be set are:)

- Intake air temperature sensor 2 failed.
- Harness damage or connector damage.
- ECM failed.

DIAGNOSIS

STEP 1. Using scan tool MB991958, check data list item DE: Intake Air Temperature Sensor 2.

⚠ CAUTION

To prevent damage to scan tool MB991958, always turn the ignition switch to the "LOCK" (OFF) position before connecting or disconnecting scan tool MB991958.

- (1) Connect scan tool MB991958 to the data link connector.
- (2) Remove the intake air temperature sensor 2 from the intake manifold.
- (3) Turn the ignition switch to the "ON" position.
- (4) Set scan tool MB991958 to the data reading mode for item DE, Intake Air Temperature Sensor 2.

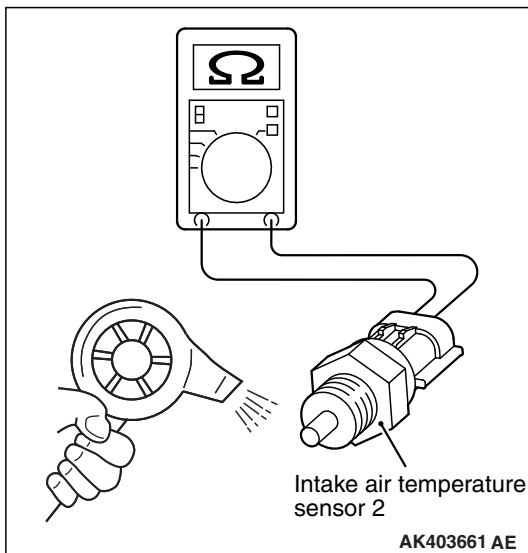
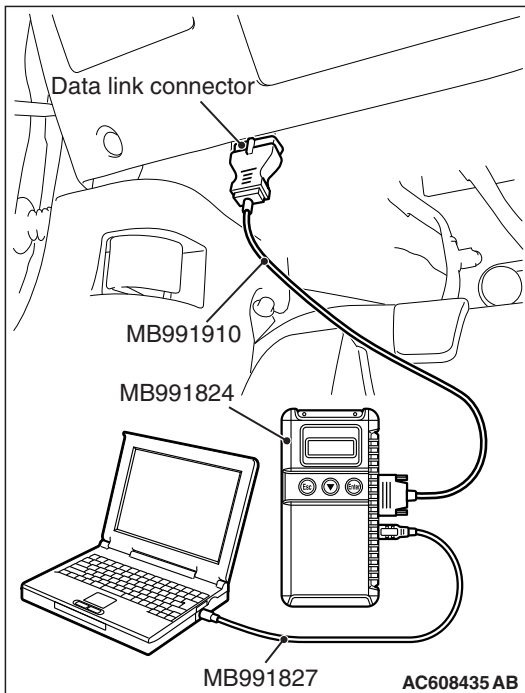

- (5) Heating the sensor using a hair drier.
 - The indicated temperature increases.

NOTE: Do not allow it to increase over 80°C (176°F).

- (6) Turn the ignition switch to the "LOCK" (OFF) position.
- (7) Attach the intake air temperature sensor 2.

Q: Is the sensor operating properly?

YES : It can be assumed that this malfunction is intermittent.
Refer to GROUP 00, How to Use
Troubleshooting/Inspection Service Points –How to
Cope with Intermittent Malfunctions [P.00-15](#).

NO : Go to Step 2.

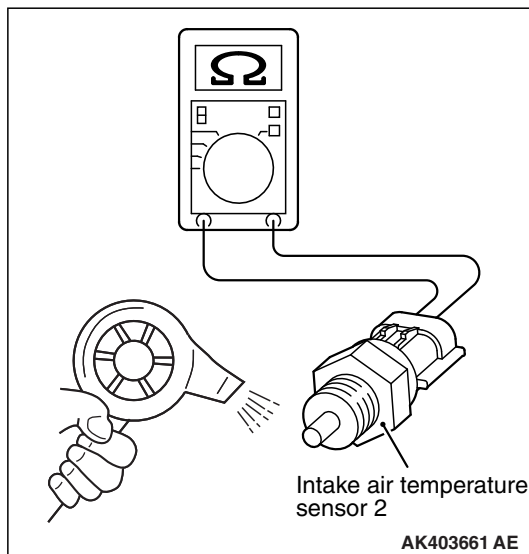
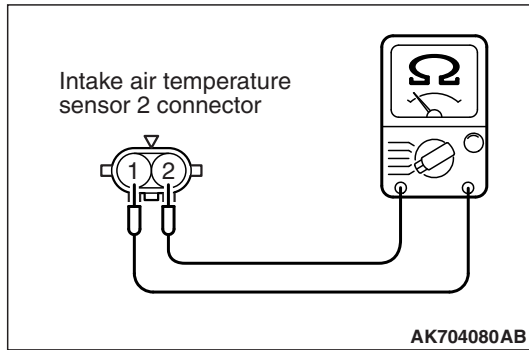
**STEP 2. Check the intake air temperature sensor 2.**

- (1) Disconnect the intake air temperature sensor 2 connector B-16.
- (2) Measure the resistance between intake air temperature sensor 2 side connector terminal No. 1 and No. 2.

- (3) Measure resistance while heating the sensor using a hair drier.

Standard value:

13 –18 kΩ [at –20° C (–4° F)]

5.1 –6.9 kΩ [at 0° C (32° F)]

2.0 –3.0 kΩ [at 20° C (68° F)]

0.9 –1.5 kΩ [at 40° C (104° F)]

0.40 –0.78 kΩ [at 60° C (140° F)]

0.23 –0.42 kΩ [at 80° C (176° F)]

Q: Is the measured resistance at the standard value?

YES : Go to Step 3.

NO : Replace the intake air temperature sensor 2. Then go to Step 9.

STEP 3. Check harness connector B-16 at the intake air temperature sensor 2 for damage.

Q: Is the harness connector in good condition?

YES : Go to Step 4.

NO : Repair or replace it. Refer to GROUP 00E, Harness Connector Inspection [P.00E-2](#). Then go to Step 9.

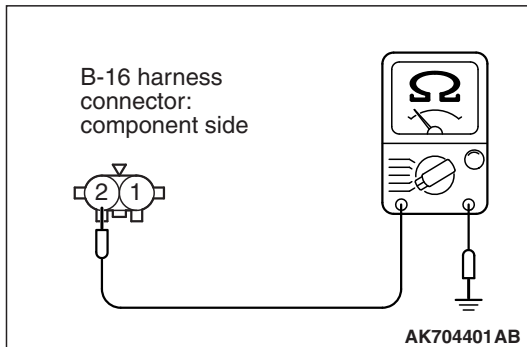

STEP 4. Check the continuity at intake air temperature sensor 2 harness side connector B-16.

- (1) Disconnect the connector B-16 and measure at the harness side.
- (2) Check for the continuity between terminal No. 2 and ground.
 - Continuity (2 ohms or less)

Q: Does continuity exist?

- YES :** Go to Step 7.
NO : Go to Step 5.

STEP 5. Check harness connector B-10 at ECM for damage.

Q: Is the harness connector in good condition?

- YES :** Go to Step 6.
NO : Repair or replace it. Refer to GROUP 00E, Harness Connector Inspection [P.00E-2](#). Then go to Step 9.

STEP 6. Check for harness damage between intake air temperature sensor 2 connector B-16 (terminal No. 2) and ECM connector B-10 (terminal No. 97).

NOTE: Check harness after checking intermediate connector A-13. If intermediate connector is damaged, repair or replace it. Repair to GROUP 00E, Harness Connector Inspection [P.00E-2](#). Then go to Step 9.

Q: Is the harness wire in good condition?

- YES :** Replace the ECM. When the ECM is replaced, register the ID code. Refer to GROUP 42B, ID Code Registration Necessity Judgment Table <Vehicles with KOS> [P.42B-11](#) or GROUP 42C, ID Codes Registration Judgment Table <Vehicles with WCM> [P.42C-9](#). Then go to Step 9.
NO : Repair it. Then go to Step 9.

STEP 7. Check harness connector B-10 at ECM for damage.

Q: Is the harness connector in good condition?

- YES :** Go to Step 8.
NO : Repair or replace it. Refer to GROUP 00E, Harness Connector Inspection [P.00E-2](#). Then go to Step 9.

STEP 8. Check for harness damage between intake air temperature sensor 2 connector B-16 (terminal No. 1) and ECM connector B-10 (terminal No. 98).

NOTE: Check harness after checking intermediate connector A-13. If intermediate connector is damaged, repair or replace it. Repair to GROUP 00E, Harness Connector Inspection P.00E-2. Then go to Step 9.

Q: Is the harness wire in good condition?

YES : Replace the ECM. When the ECM is replaced, register the ID code. Refer to GROUP 42B, ID Code Registration Necessity Judgment Table <Vehicles with KOS> P.42B-11 or GROUP 42C, ID Codes Registration Judgment Table <Vehicles with WCM> P.42C-9. Then go to Step 9.

NO : Repair it. Then go to Step 9.

STEP 9. Test the OBD-II drive cycle.

(1) Carry out a test drive with the drive cycle pattern. Refer to Diagnostic Function –OBD-II Drive Cycle –Pattern 7 P.13A-9.

(2) Check the diagnostic trouble code (DTC).

Q: Is DTC P0096 set?

YES : Retry the troubleshooting.

NO : The inspection is complete.

DTC P0097: Intake Air Temperature Circuit Low Input (sensor 2)

INTAKE AIR TEMPERATURE SENSOR 2 CIRCUIT

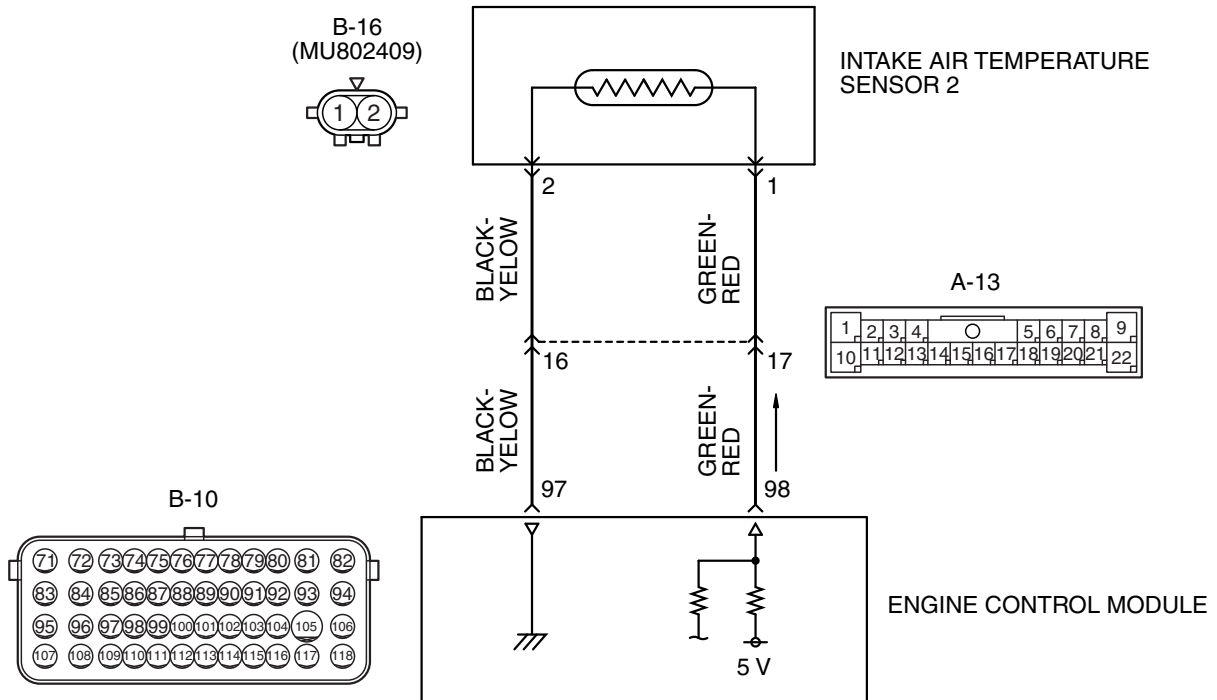

AK704399 AB

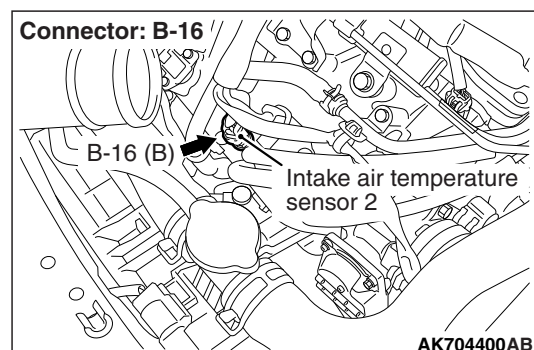
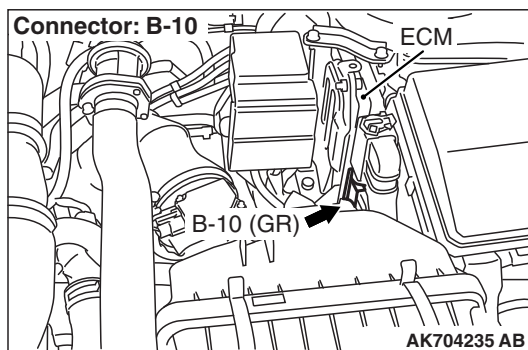

CIRCUIT OPERATION

- Approximately 5 volts are applied to the intake air temperature sensor 2 output terminal (terminal No. 1) from the ECM (terminal No. 98) via the resistor in the ECM. The ground terminal (terminal No. 2) is grounded with ECM (terminal No. 97).
- The intake air temperature sensor 2 is a negative temperature coefficient type of resistor. When the intake air temperature rises, the resistance decreases.

- The intake air temperature sensor 2 output voltage increases when the resistance increases and decreases when the resistance decreases.

TECHNICAL DESCRIPTION

- The intake air temperature sensor 2 converts the intake air temperature to a voltage.
- The ECM checks whether this voltage is within a specified range.

DESCRIPTIONS OF MONITOR METHODS

Intake air temperature sensor 2 output voltage is out of specified range.

MONITOR EXECUTION

Continuous

**MONITOR EXECUTION CONDITIONS
(Other monitor and Sensor)**

Other Monitor (There is no temporary DTC stored in memory for the item monitored below)

- Not applicable

Sensor (The sensor below is determined to be normal)

- Not applicable

DTC SET CONDITIONS

Logic Flow Chart

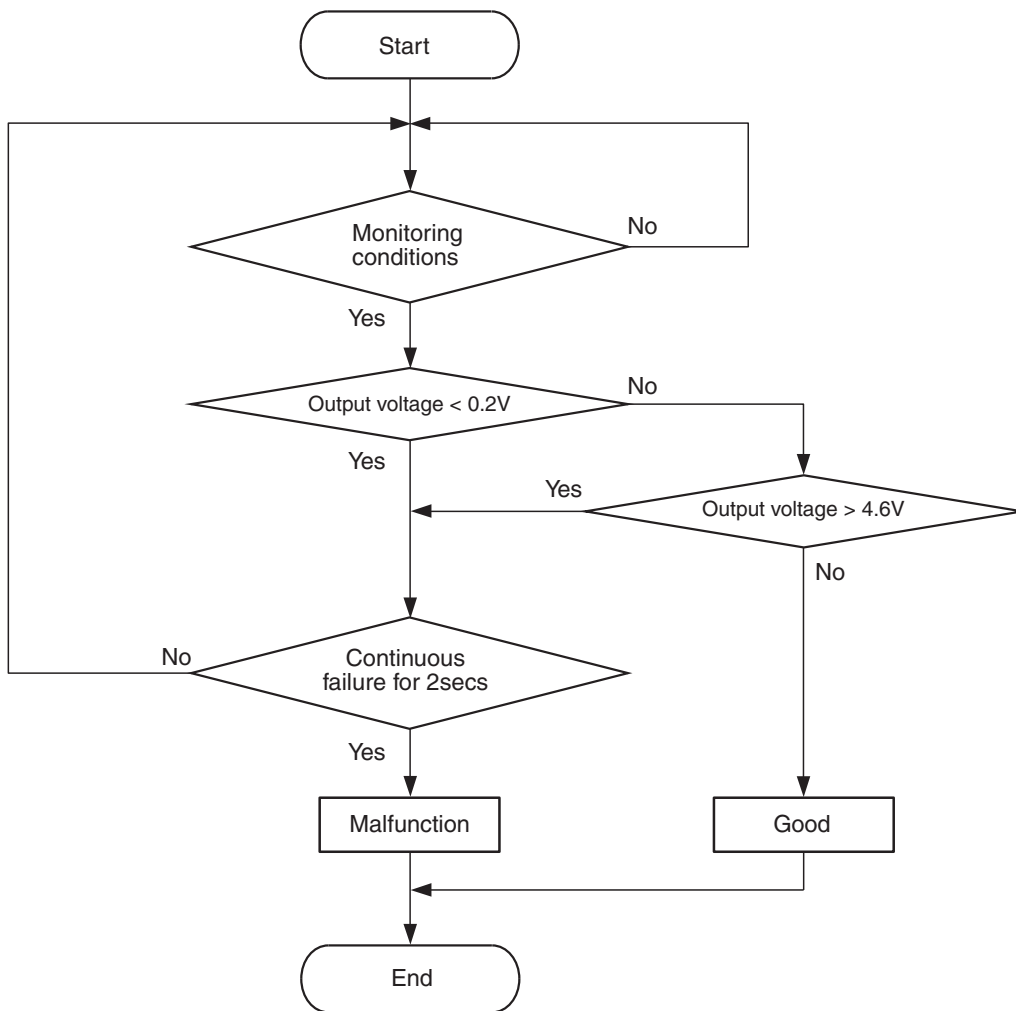

AK604315

Check Condition

- 2 seconds or more have passed since the engine starting sequence was completed.

Judgement Criterion

- Intake air temperature sensor 2 output voltage has continued to be 0.2 volt or lower [corresponding to an intake air temperature of 115° C (239° F) or higher] for 2 seconds.

FAIL-SAFE AND BACKUP FUNCTION

- Control as if the intake air temperature in the intake manifold is 25 °C.

OBD-II DRIVE CYCLE PATTERN

Refer to Diagnostic Function –OBD-II Drive Cycle – Pattern 23 [P.13A-9](#).

TROUBLESHOOTING HINTS (The most likely causes for this code to be set are:)

- Intake air temperature sensor 2 failed.
- Shorted intake air temperature sensor 2 circuit, or connector damage.
- ECM failed.

DIAGNOSIS

STEP 1. Using scan tool MB991958, check data list item DE: Intake Air Temperature Sensor 2.

⚠ CAUTION

To prevent damage to scan tool MB991958, always turn the ignition switch to the "LOCK" (OFF) position before connecting or disconnecting scan tool MB991958.

- (1) Connect scan tool MB991958 to the data link connector.
- (2) Turn the ignition switch to the "ON" position.
- (3) Set scan tool MB991958 to the data reading mode for item DE, Intake Air Temperature Sensor 2.
 - The intake air temperature and temperature shown with the scan tool should approximately match.
- (4) Turn the ignition switch to the "LOCK" (OFF) position.

Q: Is the sensor operating properly?

YES : It can be assumed that this malfunction is intermittent. Refer to GROUP 00, How to Use Troubleshooting/Inspection Service Points –How to Cope with Intermittent Malfunctions [P.00-15](#).

NO : Go to Step 2.

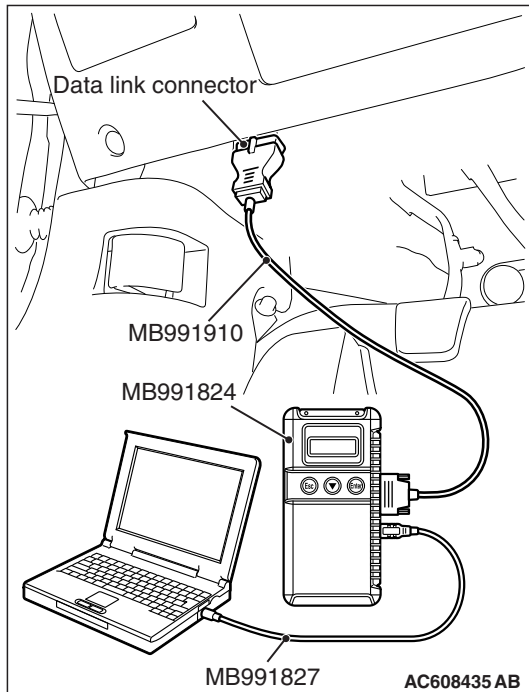

STEP 2. Check harness connector B-16 at the intake air temperature sensor 2 for damage.

Q: Is the harness connector in good condition?

YES : Go to Step 3.

NO : Repair or replace it. Refer to GROUP 00E, Harness Connector Inspection [P.00E-2](#). Then go to Step 6.

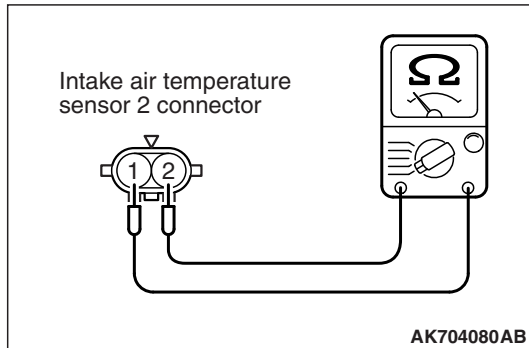

STEP 3. Check the intake air temperature sensor 2.

- (1) Disconnect the intake air temperature sensor 2 connector B-16.
- (2) Measure the resistance between intake air temperature sensor 2 side connector terminal No. 1 and No. 2.
 - There should be continuity. (0.23 –18 kΩ)

Q: Is the measured resistance between 0.23 and 18 kΩ?

YES : Go to Step 4.

NO : Replace the intake air temperature sensor 2. Then go to Step 6.

STEP 4. Check for short circuit to ground between intake air temperature sensor 2 connector B-16 (terminal No. 1) and ECM connector B-10 (terminal No. 98).

NOTE: Check harness after checking intermediate connector A-13. If intermediate connector is damaged, repair or replace it. Repair to GROUP 00E, Harness Connector Inspection P.00E-2. Then go to Step 6.

Q: Is the harness wire in good condition?

YES : Go to Step 5.

NO : Repair it. Then go to Step 6.

STEP 5. Check harness connector B-10 at ECM for damage.
Q: Is the harness connector in good condition?

YES : Replace the ECM. When the ECM is replaced, register the ID code. Refer to GROUP 42B, ID Code Registration Necessity Judgment Table <Vehicles with KOS> P.42B-11 or GROUP 42C, ID Codes Registration Judgment Table <Vehicles with WCM> P.42C-9. Then go to Step 6.

NO : Repair or replace it. Refer to GROUP 00E, Harness Connector Inspection P.00E-2. Then go to Step 6.

STEP 6. Test the OBD-II drive cycle.

- (1) Carry out a test drive with the drive cycle pattern. Refer to Diagnostic Function –OBD-II Drive Cycle –Pattern 23 P.13A-9.
- (2) Check the diagnostic trouble code (DTC).

Q: Is DTC P0097 set?

YES : Retry the troubleshooting.

NO : The inspection is complete.

DTC P0098: Intake Air Temperature Circuit High Input (sensor 2)

INTAKE AIR TEMPERATURE SENSOR 2 CIRCUIT

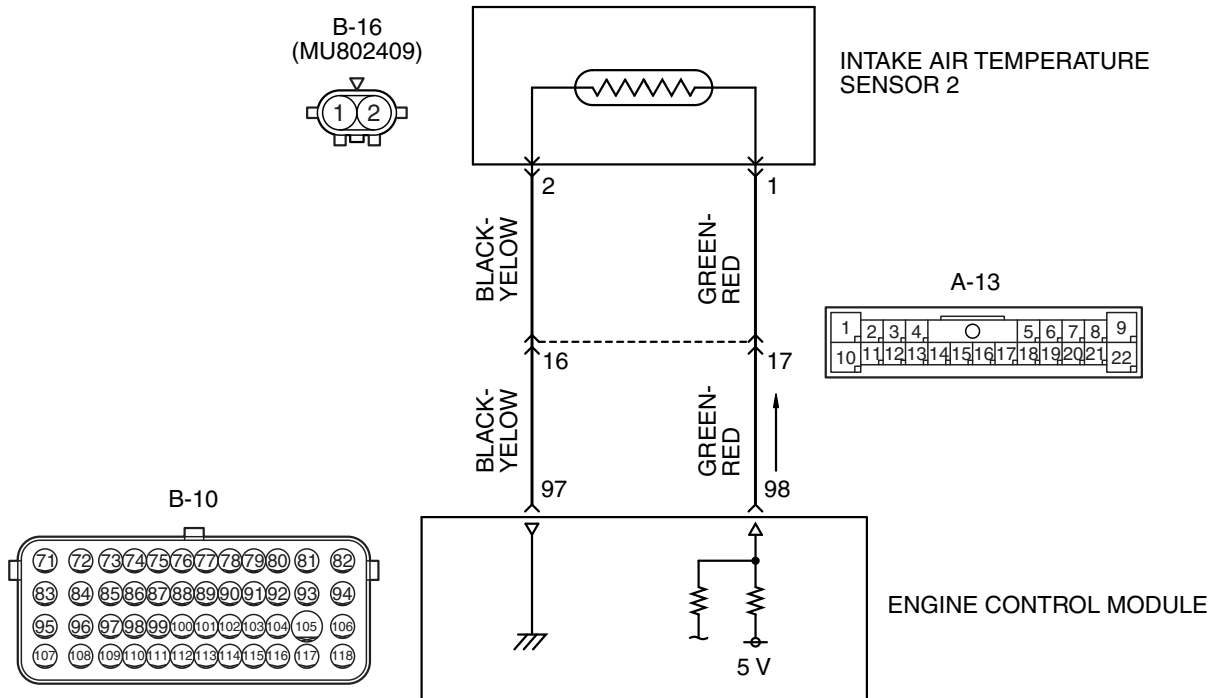

AK704399 AB

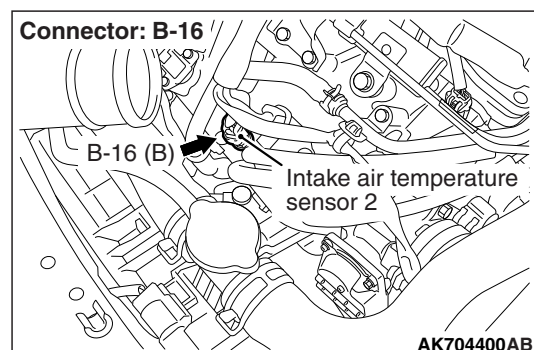
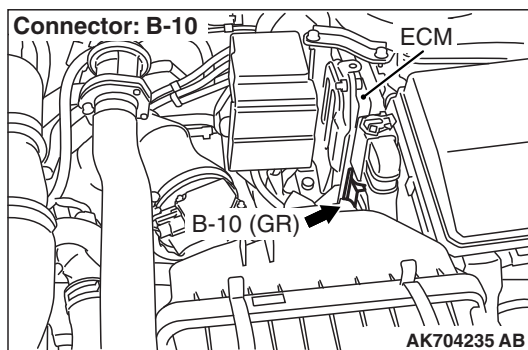

CIRCUIT OPERATION

- Approximately 5 volts are applied to the intake air temperature sensor 2 output terminal (terminal No. 1) from the ECM (terminal No. 98) via the resistor in the ECM. The ground terminal (terminal No. 2) is grounded with ECM (terminal No. 97).
- The intake air temperature sensor 2 is a negative temperature coefficient type of resistor. When the intake air temperature rises, the resistance decreases.

- The intake air temperature sensor 2 output voltage increases when the resistance increases and decreases when the resistance decreases.

TECHNICAL DESCRIPTION

- The intake air temperature sensor 2 converts the intake air temperature to a voltage.
- The ECM checks whether this voltage is within a specified range.

DESCRIPTIONS OF MONITOR METHODS

Intake air temperature sensor 2 output voltage is out of specified range.

MONITOR EXECUTION

Continuous

**MONITOR EXECUTION CONDITIONS
(Other monitor and Sensor)**

Other Monitor (There is no temporary DTC stored in memory for the item monitored below)

- Not applicable

Sensor (The sensor below is determined to be normal)

- Not applicable

DTC SET CONDITIONS

Logic Flow Chart

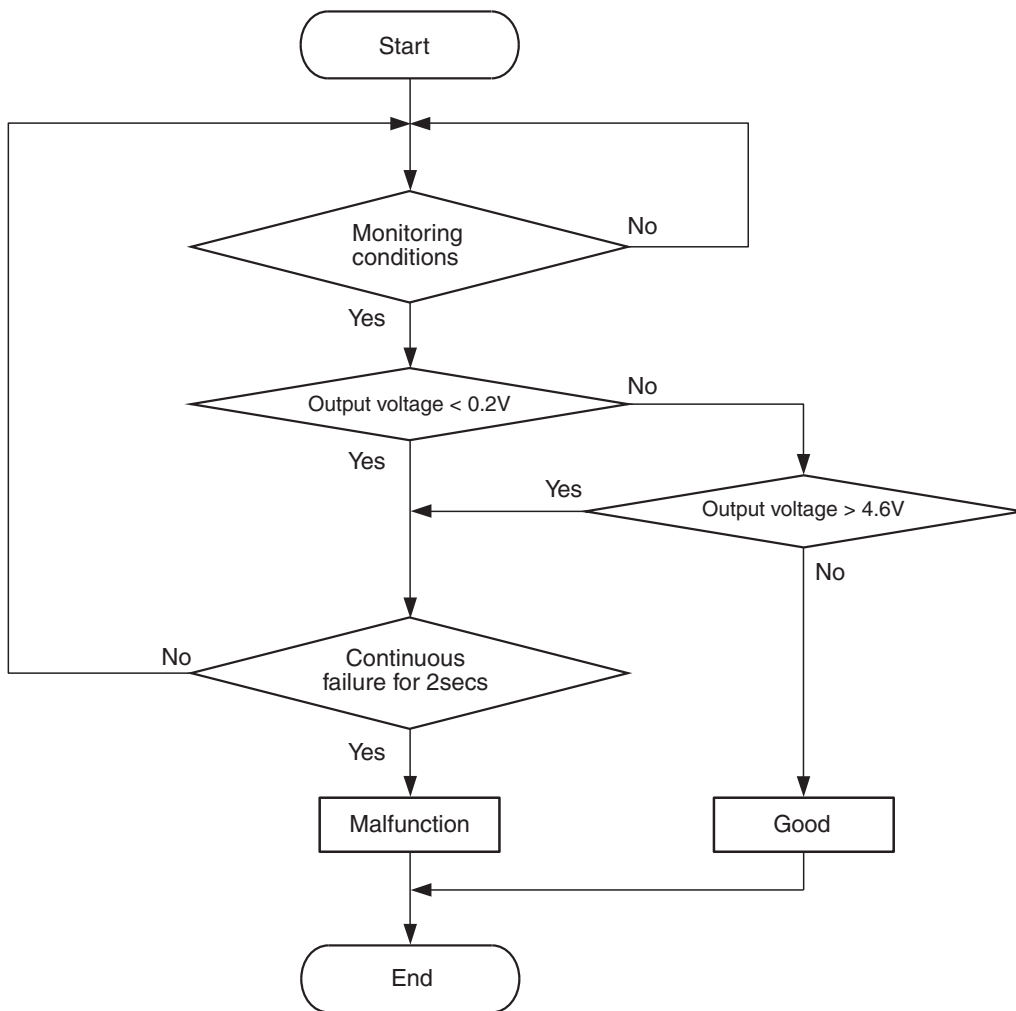

AK604315

Check Condition

- 2 seconds or more have passed since the engine starting sequence was completed.

Judgement Criterion

- Intake air temperature sensor 2 output voltage has continued to be 4.6 volts or higher [corresponding to an intake air temperature of -40° C (-40° F) or lower] for 2 seconds.

FAIL-SAFE AND BACKUP FUNCTION

- Control as if the intake air temperature in the intake manifold is 25 °C.

OBD-II DRIVE CYCLE PATTERN

Refer to Diagnostic Function –OBD-II Drive Cycle – Pattern 23 [P.13A-9](#).

TROUBLESHOOTING HINTS (The most likely causes for this code to be set are:)

- Intake air temperature sensor 2 failed.
- Open intake air temperature sensor 2 circuit, or connector damage.
- ECM failed.

DIAGNOSIS

Required Special Tools

- MB992110: Power Plant ECU Check Harness

STEP 1. Using scan tool MB991958, check data list item DE: Intake Air Temperature Sensor 2.

CAUTION

To prevent damage to scan tool MB991958, always turn the ignition switch to the "LOCK" (OFF) position before connecting or disconnecting scan tool MB991958.

- (1) Connect scan tool MB991958 to the data link connector.
- (2) Turn the ignition switch to the "ON" position.
- (3) Set scan tool MB991958 to the data reading mode for item DE, Intake Air Temperature Sensor 2.
 - The intake air temperature and temperature shown with the scan tool should approximately match.
- (4) Turn the ignition switch to the "LOCK" (OFF) position.

Q: Is the sensor operating properly?

YES : It can be assumed that this malfunction is intermittent. Refer to GROUP 00, How to Use Troubleshooting/Inspection Service Points –How to Cope with Intermittent Malfunctions [P.00-15](#).

NO : Go to Step 2.

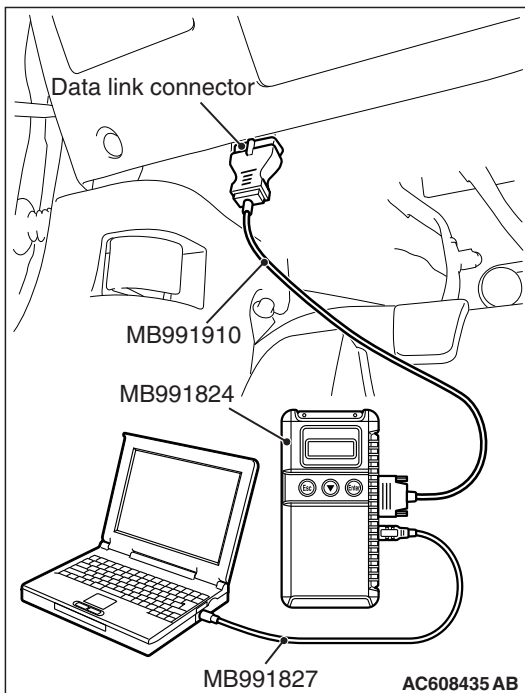

STEP 2. Check harness connector B-16 at the intake air temperature sensor 2 for damage.

Q: Is the harness connector in good condition?

YES : Go to Step 3.

NO : Repair or replace it. Refer to GROUP 00E, Harness Connector Inspection [P.00E-2](#). Then go to Step 10.

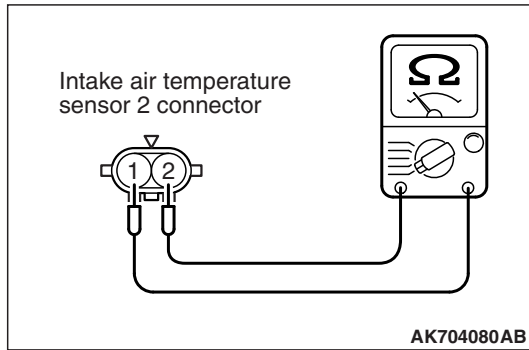
**STEP 3. Check the intake air temperature sensor 2.**

- (1) Disconnect the intake air temperature sensor 2 connector B-16.
- (2) Measure the resistance between intake air temperature sensor 2 side connector terminal No. 1 and No. 2.
 - There should be continuity. (0.23 – 18 k Ω)

Q: Is the measured resistance between 0.23 and 18 k Ω ?

YES : Go to Step 4.

NO : Replace the intake air temperature sensor 2. Then go to Step 10.

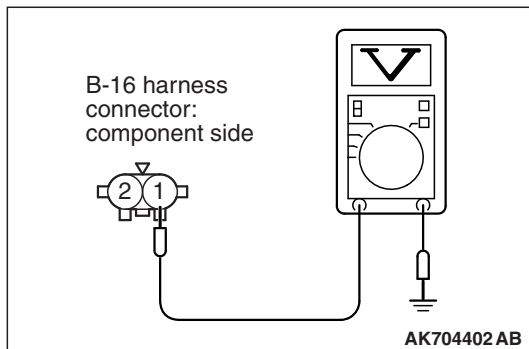
**STEP 4. Measure the sensor supply voltage at intake air temperature sensor 2 harness side connector B-16.**

- (1) Disconnect the connector B-16 and measure at the harness side.
- (2) Turn the ignition switch to the "ON" position.
- (3) Measure the voltage between terminal No. 1 and ground.
 - Voltage should be between 4.5 and 4.9 volts.
- (4) Turn the ignition switch to the "LOCK" (OFF) position.

Q: Is the measured voltage between 4.5 and 4.9 volts?

YES : Go to Step 7.

NO : Go to Step 5.

STEP 5. Check harness connector B-10 at ECM for damage.

Q: Is the harness connector in good condition?

YES : Go to Step 6.

NO : Repair or replace it. Refer to GROUP 00E, Harness Connector Inspection [P.00E-2](#). Then go to Step 10.

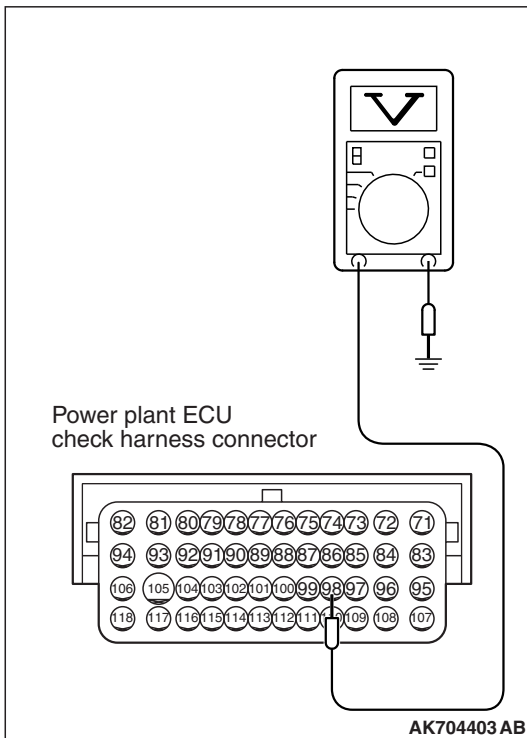
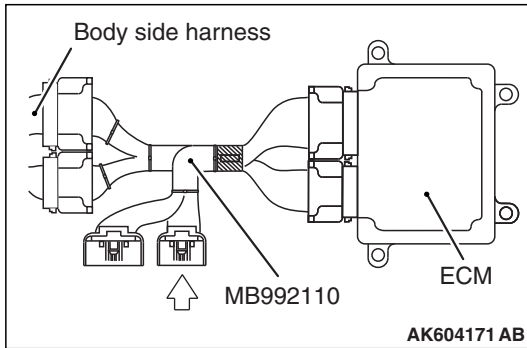

STEP 6. Measure the sensor supply voltage at ECM connector B-10 by using power plant ECU check harness special tool MB992110.

- (1) Disconnect all ECM connectors. Connect the power plant ECU check harness special tool MB992110 between the separated connectors.
- (2) Disconnect the intake air temperature sensor 2 connector B-16.
- (3) Turn the ignition switch to the "ON" position.

- (4) Measure the voltage between terminal No. 98 and ground.
 - Voltage should be between 4.5 and 4.9 volts.
- (5) Turn the ignition switch to the "LOCK" (OFF) position.

Q: Is the measured voltage between 4.5 and 4.9 volts?

YES : Check harness connector A-13 at intermediate connector for damage, and repair or replace as required. Refer to GROUP 00E, Harness Connector Inspection [P.00E-2](#). If intermediate connector is in good condition, repair harness wire between intake air temperature sensor 2 connector B-16 (terminal No. 1) and ECM connector B-10 (terminal No. 98) because of open circuit. Then go to Step 10.

NO : Replace the ECM. When the ECM is replaced, register the ID code. Refer to GROUP 42B, ID Code Registration Necessity Judgment Table <Vehicles with KOS> [P.42B-11](#) or GROUP 42C, ID Codes Registration Judgment Table <Vehicles with WCM> [P.42C-9](#). Then go to Step 10.

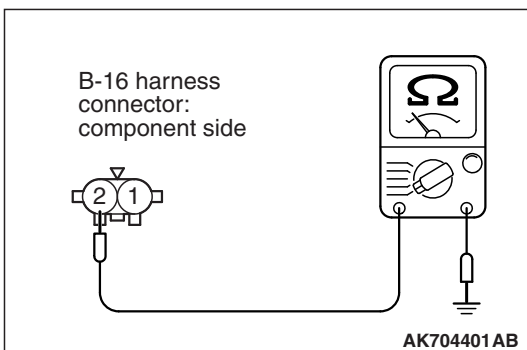

STEP 7. Check the continuity at intake air temperature sensor 2 harness side connector B-16.

- (1) Disconnect the connector B-16 and measure at the harness side.
- (2) Check for the continuity between terminal No. 2 and ground.
 - Continuity (2 ohms or less)

Q: Does continuity exist?

YES : Replace the ECM. When the ECM is replaced, register the ID code. Refer to GROUP 42B, ID Code Registration Necessity Judgment Table <Vehicles with KOS> [P.42B-11](#) or GROUP 42C, ID Codes Registration Judgment Table <Vehicles with WCM> [P.42C-9](#). Then go to Step 10.

NO : Go to Step 8.

STEP 8. Check harness connector B-10 at ECM for damage.

Q: Is the harness connector in good condition?

YES : Go to Step 9.

NO : Repair or replace it. Refer to GROUP 00E, Harness Connector Inspection [P.00E-2](#). Then go to Step 10.

STEP 9. Check for open circuit between intake air temperature sensor 2 connector B-16 (terminal No. 2) and ECM connector B-10 (terminal No. 97).

NOTE: Check harness after checking intermediate connector A-13. If intermediate connector is damaged, repair or replace it. Repair to GROUP 00E, Harness Connector Inspection [P.00E-2](#). Then go to Step 10.

Q: Is the harness wire in good condition?

YES : Replace the ECM. When the ECM is replaced, register the ID code. Refer to GROUP 42B, ID Code Registration Necessity Judgment Table <Vehicles with KOS> [P.42B-11](#) or GROUP 42C, ID Codes Registration Judgment Table <Vehicles with WCM> [P.42C-9](#). Then go to Step 10.

NO : Repair it. Then go to Step 10.

STEP 10. Test the OBD-II drive cycle.

(1) Carry out a test drive with the drive cycle pattern. Refer to Diagnostic Function –OBD-II Drive Cycle –Pattern 23 [P.13A-9](#).

(2) Check the diagnostic trouble code (DTC).

Q: Is DTC P0098 set?

YES : Retry the troubleshooting.

NO : The inspection is complete.

DTC P0101: Mass Airflow Circuit Range/Performance Problem

MASS AIRFLOW SENSOR CIRCUIT

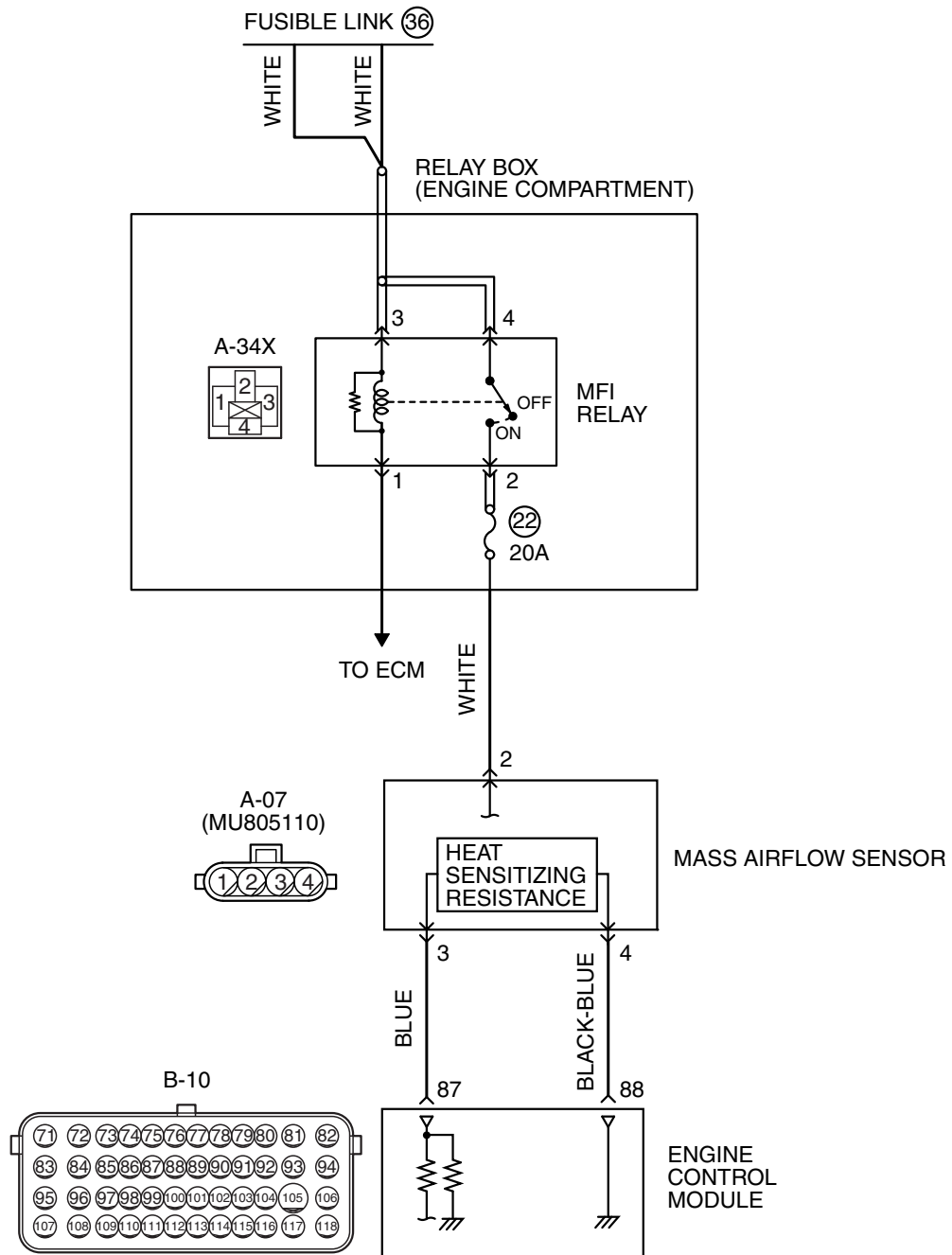

AK704233 AB

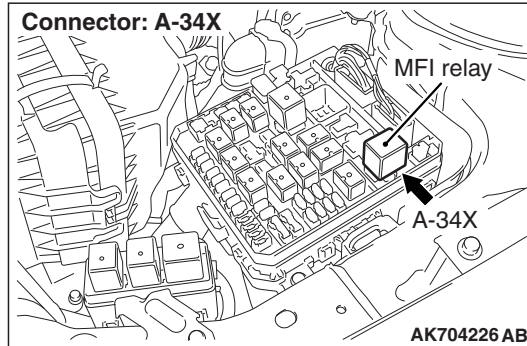
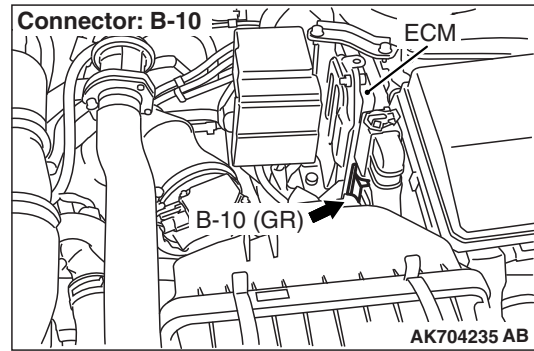
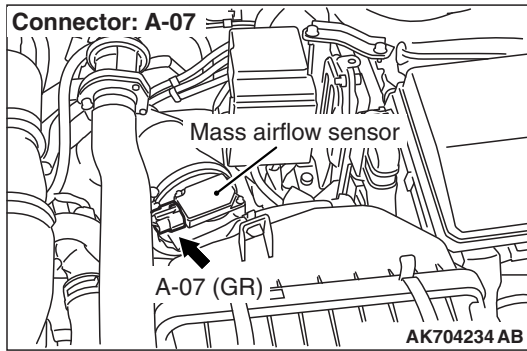

CIRCUIT OPERATION

- The mass airflow sensor power is supplied from the MFI relay (terminal No. 2), and the ground is provided on the ECM (terminal No. 88).
- A voltage that is according to the mass airflow rate is sent to the ECM (terminal No. 87) from the mass airflow sensor output terminal (terminal No. 3).

TECHNICAL DESCRIPTION

- While the engine is running, the mass airflow sensor outputs electric current which corresponds to the mass airflow rate.
- The ECM converts the electric current into the voltage and checks whether the voltage is within a specified range while the engine is running.

DESCRIPTIONS OF MONITOR METHODS

Compare load value with mass airflow sensor output voltage.

MONITOR EXECUTION

Continuous

MONITOR EXECUTION CONDITIONS (Other monitor and Sensor)

Other Monitor (There is no temporary DTC stored in memory for the item monitored below)

- Not applicable

Sensor (The sensor below is determined to be normal)

- Throttle position sensor

DTC SET CONDITIONS <Range/Performance problem –high>

Logic Flow Chart

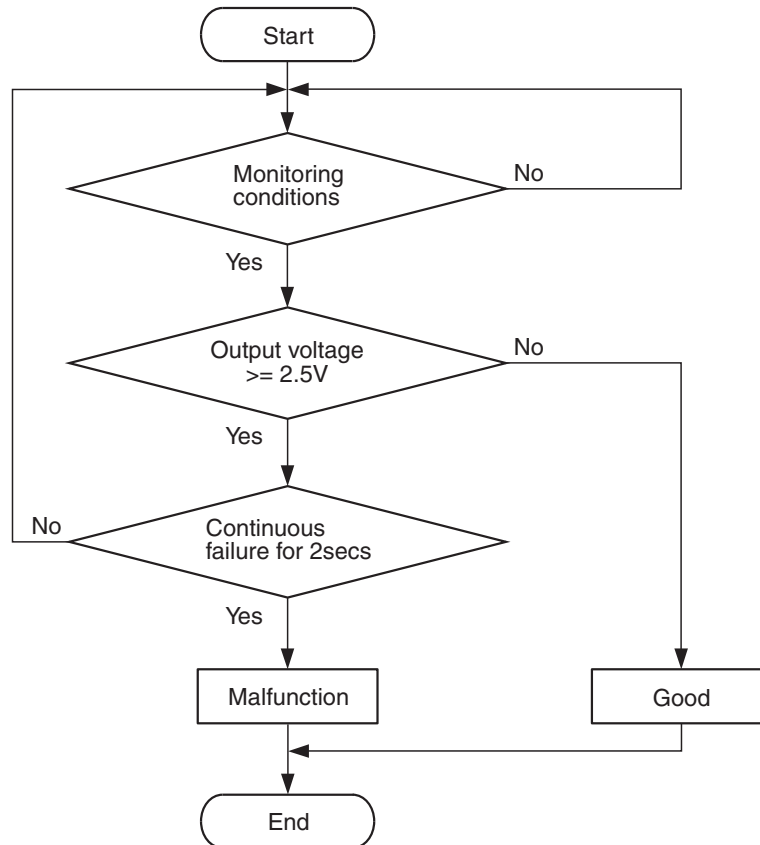

AK801001

Check Conditions

- Throttle position sensor output voltage is 0.8 volt or lower.
- Mass airflow sensor output voltage is 4.9 volts (corresponding to an air flow rate of 387 g/sec) or lower.

Judgement Criterion

- Mass airflow sensor output voltage has continued to be 2.5 volts (corresponding to an air flow rate of 37 g/sec) or higher for 2 seconds.

DTC SET CONDITIONS <Range/Performance problem –low >

Logic Flow Chart

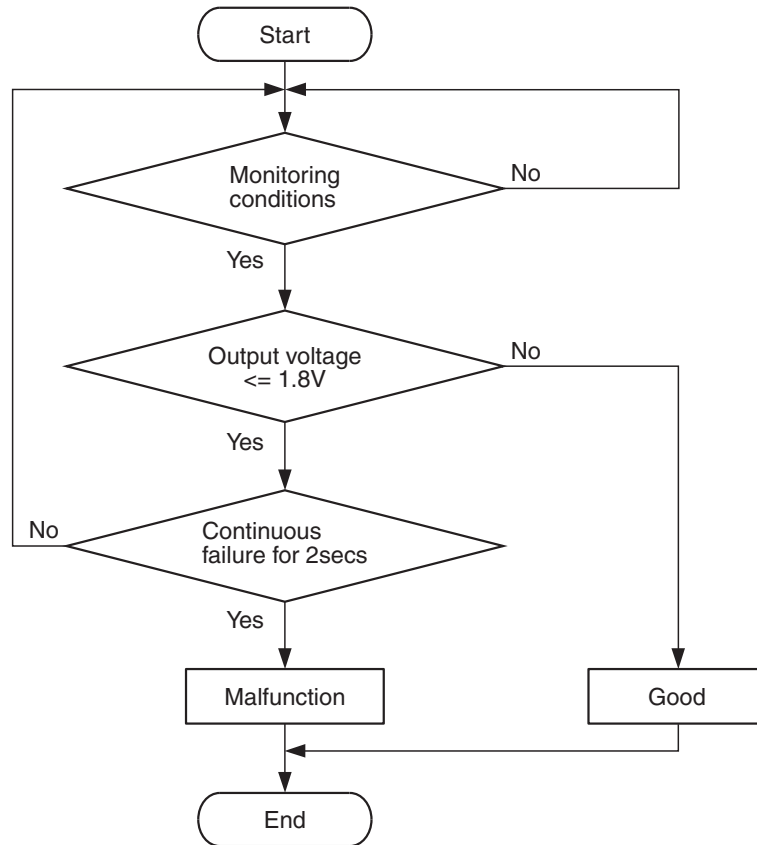

AK604309

Check Conditions

- Engine speed is 1,500 r/min or higher.
- Throttle position sensor output voltage is 1.5 volts or higher.
- Mass airflow sensor output voltage is 0.2 volt (corresponding to an air flow rate of 0 g/sec) or higher.

Judgement Criterion

- Mass airflow sensor output voltage has continued to be 1.8 volts (corresponding to an air flow rate of 10 g/sec) or lower for 2 seconds.

FAIL-SAFE AND BACKUP FUNCTION

- None

OBD-II DRIVE CYCLE PATTERN

Refer to Diagnostic Function –OBD-II Drive Cycle – Pattern 6 [P.13A-9](#).

TROUBLESHOOTING HINTS (The most likely causes for this code to be set are:)

- Mass airflow sensor failed.
- Mass airflow sensor circuit harness damage, or connector damage.
- ECM failed.

DIAGNOSIS

Required Special Tools:

- MB991958: Scan tool (M.U.T.-III Sub Assembly)
 - MB991824: V.C.I.
 - MB991827: USB Cable
 - MB991910: Main Harness A

STEP 1. Using scan tool MB991958, check data list item 10: Mass Airflow Sensor.

CAUTION

To prevent damage to scan tool MB991958, always turn the ignition switch to the "LOCK" (OFF) position before connecting or disconnecting scan tool MB991958.

- (1) Connect scan tool MB991958 to the data link connector.
- (2) Start the engine and run at idle.
- (3) Set scan tool MB991958 to the data reading mode for item 10, Mass Airflow Sensor.
- (4) Warm up the engine to normal operating temperature: 80° C to 95° C (176° F to 203° F).
 - The standard value during idling should be between 1,300 and 1,650 millivolts.
 - When the engine is revved, the mass airflow rate should increase according to the increase in engine speed.
- (5) Turn the ignition switch to the "LOCK" (OFF) position.

Q: Is the sensor operating properly?

YES : It can be assumed that this malfunction is intermittent. Refer to GROUP 00, How to Use Troubleshooting/Inspection Service Points –How to Cope with Intermittent Malfunctions [P.00-15](#).

NO : Go to Step 2.

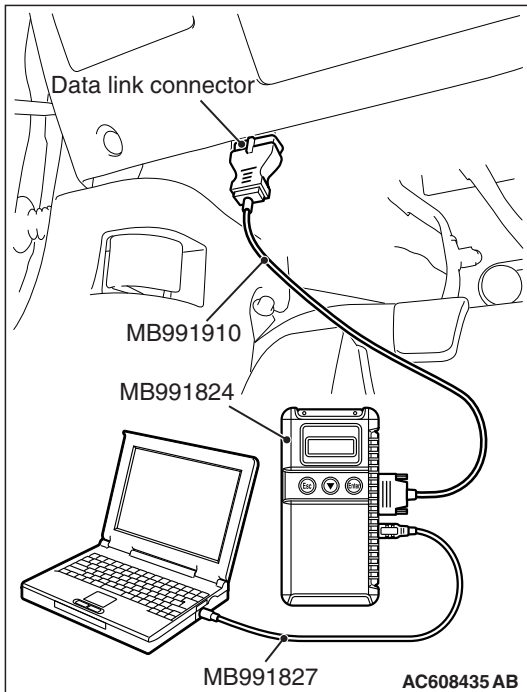

STEP 2. Check harness connector A-07 at mass airflow sensor and harness connector A-34X at MFI relay for damage.

Q: Is the harness connector in good condition?

YES : Go to Step 3.

NO : Repair or replace it. Refer to GROUP 00E, Harness Connector Inspection [P.00E-2](#). Then go to Step 8.

STEP 3. Check for harness damage between MFI relay connector A-34X (terminal No. 2) and mass airflow sensor connector A-07 (terminal No. 2).

Q: Is the harness wire in good condition?

YES : Go to Step 4.

NO : Repair it. Then go to Step 8.

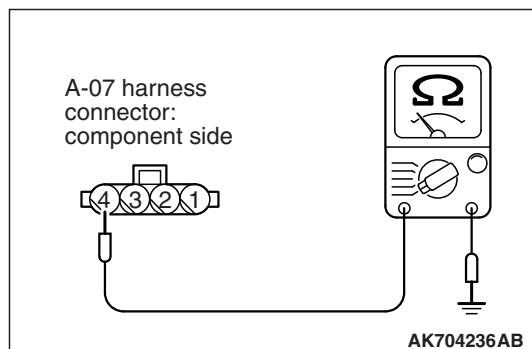

STEP 4. Check harness connector B-10 at ECM for damage.

Q: Is the harness connector in good condition?

YES : Go to Step 5.

NO : Repair or replace it. Refer to GROUP 00E, Harness Connector Inspection [P.00E-2](#). Then go to Step 8.

STEP 5. Check the continuity at mass airflow sensor harness side connector A-07.

- (1) Disconnect the connector A-07 and measure at the harness side.
- (2) Check for the continuity between terminal No. 4 and ground.
 - Continuity (2 ohms or less)

Q: Does continuity exist?

YES : Go to Step 6.

NO : Repair harness wire between mass airflow sensor connector A-07 (terminal No. 4) and ECM connector B-10 (terminal No. 88) because of harness damage. Then go to Step 8.

STEP 6. Check for harness damage between mass airflow sensor connector A-07 (terminal No. 3) and ECM connector B-10 (terminal No. 87).

Q: Is the harness wire in good condition?

YES : Go to Step 7.

NO : Repair it. Then go to Step 8.

STEP 7. Replace the mass airflow sensor.

- (1) Replace the mass airflow sensor.
- (2) Carry out a test drive with the drive cycle pattern. Refer to Diagnostic Function –OBD-II Drive Cycle –Pattern 6 [P.13A-9](#).
- (3) Check the diagnostic trouble code (DTC).

Q: Is DTC P0101 set?

YES : Replace the ECM. When the ECM is replaced, register the ID code. Refer to GROUP 42B, ID Code Registration Necessity Judgment Table <Vehicles with KOS> [P.42B-11](#) or GROUP 42C, ID Codes Registration Judgment Table <Vehicles with WCM> [P.42C-9](#). Then go to Step 8.

NO : The inspection is complete.

STEP 8. Test the OBD-II drive cycle.

- (1) Carry out a test drive with the drive cycle pattern. Refer to Diagnostic Function –OBD-II Drive Cycle –Pattern 6 [P.13A-9](#).
- (2) Check the diagnostic trouble code (DTC).

Q: Is DTC P0101 set?

YES : Retry the troubleshooting.

NO : The inspection is complete.

DTC P0102: Mass Airflow Circuit Low Input

MASS AIRFLOW SENSOR CIRCUIT

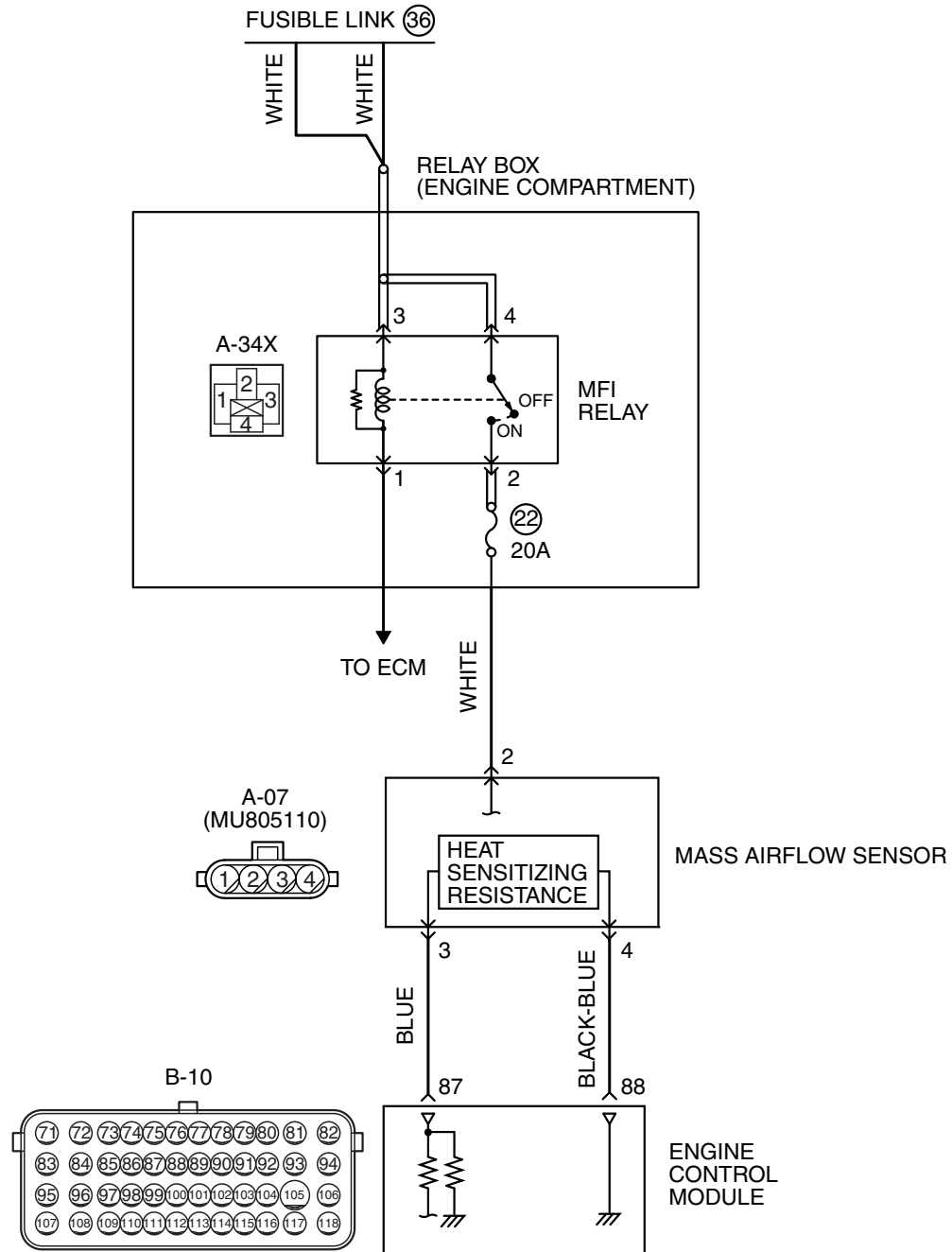

AK704233 AB

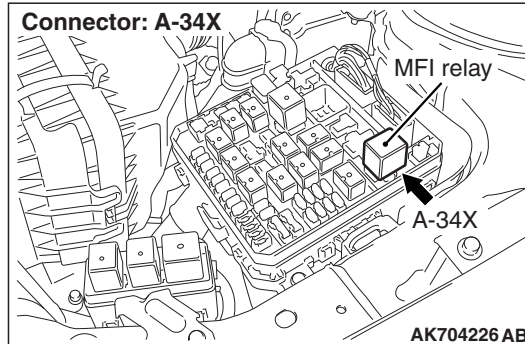
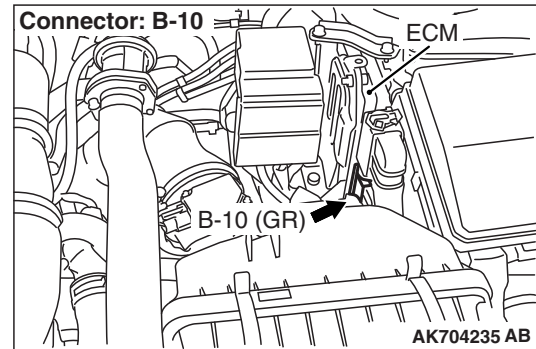
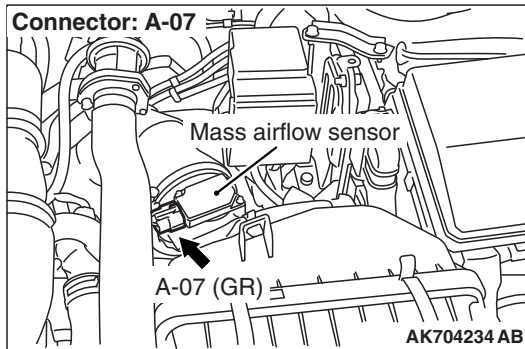

CIRCUIT OPERATION

- The mass airflow sensor power is supplied from the MFI relay (terminal No. 2), and the ground is provided on the ECM (terminal No. 88).
- A voltage that is according to the mass airflow rate is sent to the ECM (terminal No. 87) from the mass airflow sensor output terminal (terminal No. 3).

TECHNICAL DESCRIPTION

- While the engine is running, the mass airflow sensor outputs voltage which corresponds to the mass airflow rate.
- The ECM checks whether the voltage output by the mass airflow sensor while the engine is running is within a specified range.

DESCRIPTIONS OF MONITOR METHODS

Mass airflow sensor output voltage is out of specified range.

MONITOR EXECUTION

Continuous

MONITOR EXECUTION CONDITIONS (Other monitor and Sensor)

Other Monitor (There is no temporary DTC stored in memory for the item monitored below)

- Not applicable

Sensor (The sensor below is determined to be normal)

- Not applicable

DTC SET CONDITIONS

Logic Flow Chart

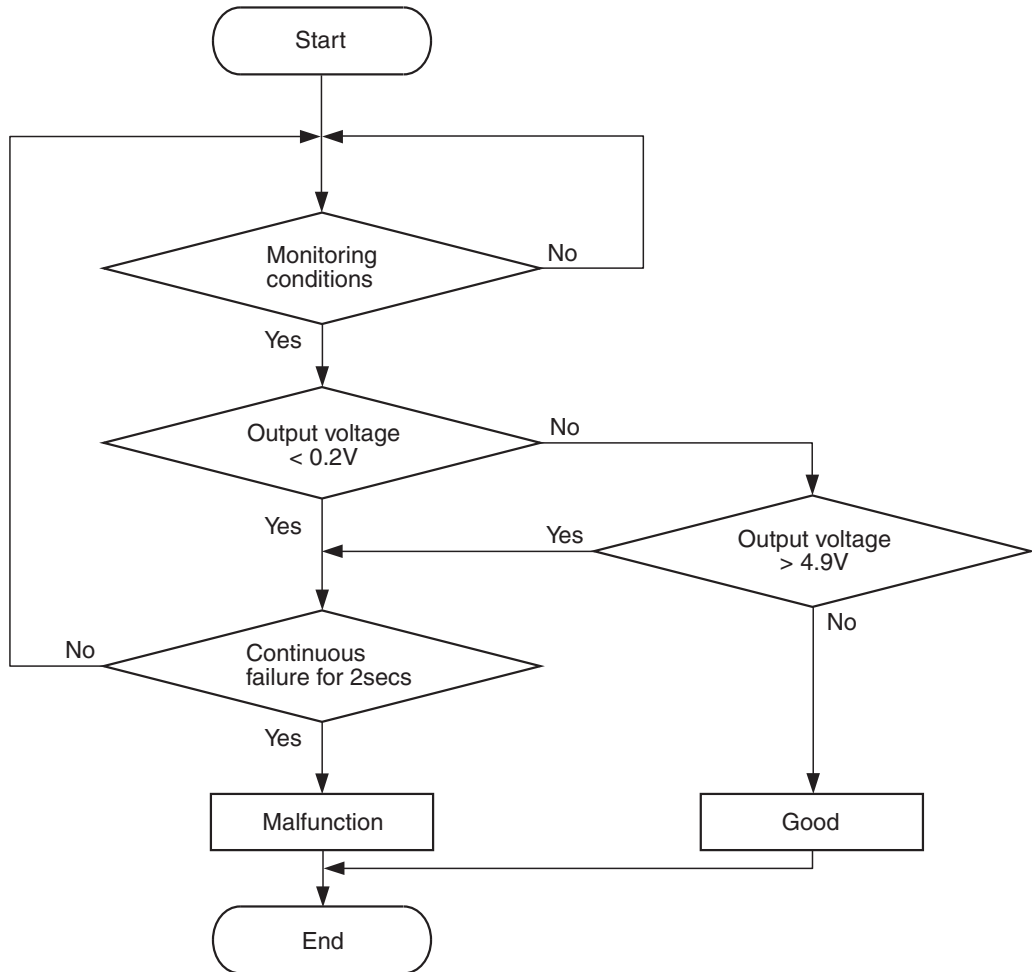

AK604310

Check Condition

- 3 seconds or more have passed since the ignition switch was turned to "ON" position.

Judgement Criterion

- Mass airflow sensor output voltage has continued to be lower than 0.2 volt (corresponding to an air flow rate of 0 g/sec) for 2 seconds.

FAIL-SAFE AND BACKUP FUNCTION

- None

OBD-II DRIVE CYCLE PATTERN

Refer to Diagnostic Function –OBD-II Drive Cycle – Pattern 23 [P.13A-9](#).

TROUBLESHOOTING HINTS (The most likely causes for this code to be set are:)

- Mass airflow sensor failed.
- Open or shorted mass airflow sensor circuit, or connector damage.
- ECM failed.

DIAGNOSIS

Required Special Tools:

- MB991958: Scan tool (M.U.T.-III Sub Assembly)
 - MB991824: V.C.I.
 - MB991827: USB Cable
 - MB991910: Main Harness A
- MB992110: Power Plant ECU Check Harness

STEP 1. Using scan tool MB991958, check data list item 10: Mass Airflow Sensor.

⚠ CAUTION

To prevent damage to scan tool MB991958, always turn the ignition switch to the "LOCK" (OFF) position before connecting or disconnecting scan tool MB991958.

- (1) Connect scan tool MB991958 to the data link connector.
- (2) Start the engine and run at idle.
- (3) Set scan tool MB991958 to the data reading mode for item 10, Mass Airflow Sensor.
- (4) Warm up the engine to normal operating temperature: 80° C to 95° C (176° F to 203° F).
 - The standard value during idling should be between 1,300 and 1,650 millivolts.
 - When the engine is revved, the mass airflow rate should increase according to the increase in engine speed.
- (5) Turn the ignition switch to the "LOCK" (OFF) position.

Q: Is the sensor operating properly?

YES : It can be assumed that this malfunction is intermittent. Refer to GROUP 00, How to Use Troubleshooting/Inspection Service Points –How to Cope with Intermittent Malfunctions [P.00-15](#).

NO : Go to Step 2.

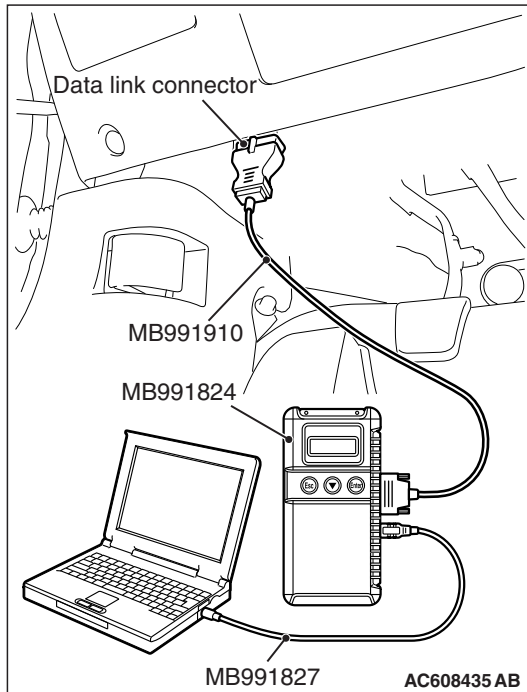

STEP 2. Check harness connector A-07 at mass airflow sensor for damage.

Q: Is the harness connector in good condition?

YES : Go to Step 3.

NO : Repair or replace it. Refer to GROUP 00E, Harness Connector Inspection [P.00E-2](#). Then go to Step 10.

STEP 3. Measure the power supply voltage at mass airflow sensor harness side connector A-07.

- (1) Disconnect the connector A-07 and measure at the harness side.
- (2) Turn the ignition switch to the "ON" position.
- (3) Measure the voltage between terminal No. 2 and ground.
 - Voltage should be battery positive voltage.
- (4) Turn the ignition switch to the "LOCK" (OFF) position.

Q: Is battery positive voltage (approximately 12 volts) present?

YES : Go to Step 5.

NO : Go to Step 4.

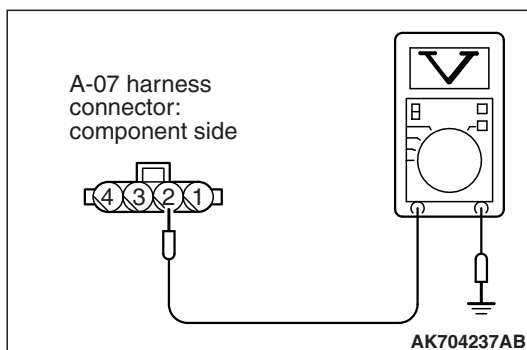

STEP 4. Check harness connector A-34X at MFI relay for damage.

Q: Is the harness connector in good condition?

YES : Repair harness wire between MFI relay connector A-34X (terminal No. 2) and mass airflow sensor connector A-07 (terminal No. 2) because of open circuit or short circuit to ground. Then go to Step 10.

NO : Repair or replace it. Refer to GROUP 00E, Harness Connector Inspection [P.00E-2](#). Then go to Step 10.

STEP 5. Check harness connector B-10 at ECM for damage.

Q: Is the harness connector in good condition?

YES : Go to Step 6.

NO : Repair or replace it. Refer to GROUP 00E, Harness Connector Inspection [P.00E-2](#). Then go to Step 10.

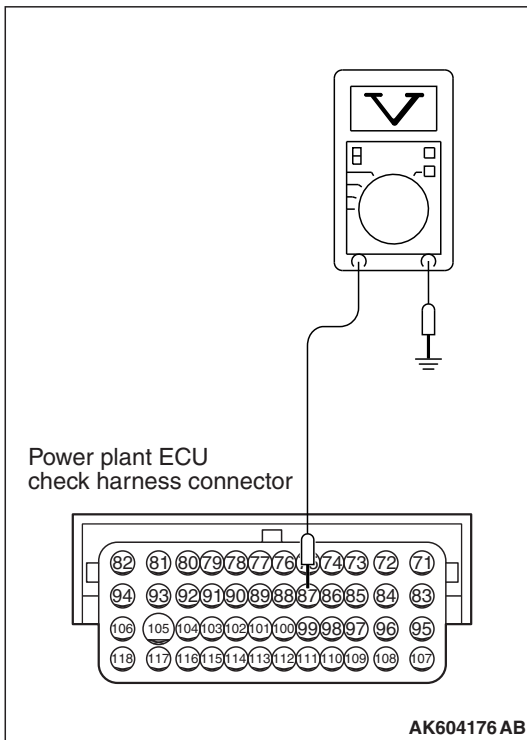
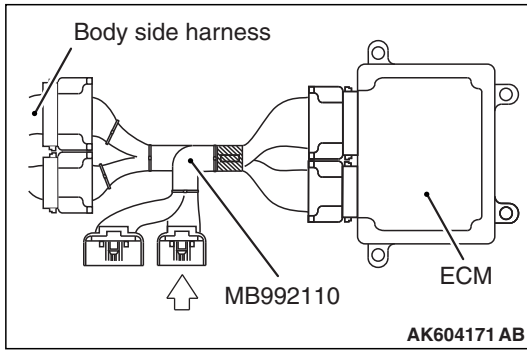

STEP 6. Measure the sensor output voltage at ECM connector B-10 by using power plant ECU check harness special tool MB992110.

(1) Disconnect all ECM connectors. Connect the power plant ECU check harness special tool MB992110 between the separated connectors.

(2) Start the engine.

(3) Measure the voltage between terminal No. 87 and ground.

- When the engine is revved, voltage should be increase in response to revving.

Q: Is the measured voltage normal?

YES : Go to Step 9.

NO : Go to Step 7.

STEP 7. Check for open circuit and short circuit to ground between mass airflow sensor connector A-07 (terminal No. 3) and ECM connector B-10 (terminal No. 87).

Q: Is the harness wire in good condition?

YES : Go to Step 8.

NO : Repair it. Then go to Step 10.

STEP 8. Replace the mass airflow sensor.

- (1) Replace the mass airflow sensor.
- (2) Carry out a test drive with the drive cycle pattern. Refer to Diagnostic Function –OBD-II Drive Cycle –Pattern 23 [P.13A-9](#).
- (3) Check the diagnostic trouble code (DTC).

Q: Is DTC P0102 set?

YES : Replace the ECM. When the ECM is replaced, register the ID code. Refer to GROUP 42B, ID Code Registration Necessity Judgment Table <Vehicles with KOS> [P.42B-11](#) or GROUP 42C, ID Codes Registration Judgment Table <Vehicles with WCM> [P.42C-9](#). Then go to Step 10.

NO : The inspection is complete.

STEP 9. Using scan tool MB991958, check data list item 10: Mass Airflow Sensor.

- (1) Start the engine and run at idle.
- (2) Set scan tool MB991958 to the data reading mode for item 10, Mass Airflow Sensor.
- (3) Warm up the engine to normal operating temperature: 80° C to 95° C (176° F to 203° F).
 - The standard value during idling should be between 1,300 and 1,650 millivolts.
 - When the engine is revved, the mass airflow rate should increase according to the increase in engine speed.
- (4) Turn the ignition switch to the "LOCK" (OFF) position.

Q: Is the sensor operating properly?

YES : It can be assumed that this malfunction is intermittent. Refer to GROUP 00, How to Use Troubleshooting/Inspection Service Points –How to Cope with Intermittent Malfunctions [P.00-15](#).

NO : Replace the ECM. When the ECM is replaced, register the ID code. Refer to GROUP 42B, ID Code Registration Necessity Judgment Table <Vehicles with KOS> [P.42B-11](#) or GROUP 42C, ID Codes Registration Judgment Table <Vehicles with WCM> [P.42C-9](#). Then go to Step 10.

STEP 10. Test the OBD-II drive cycle.

- (1) Carry out a test drive with the drive cycle pattern. Refer to Diagnostic Function –OBD-II Drive Cycle –Pattern 23 [P.13A-9](#).
- (2) Check the diagnostic trouble code (DTC).

Q: Is DTC P0102 set?

YES : Retry the troubleshooting.

NO : The inspection is complete.

DTC P0103: Mass Airflow Circuit High Input

MASS AIRFLOW SENSOR CIRCUIT

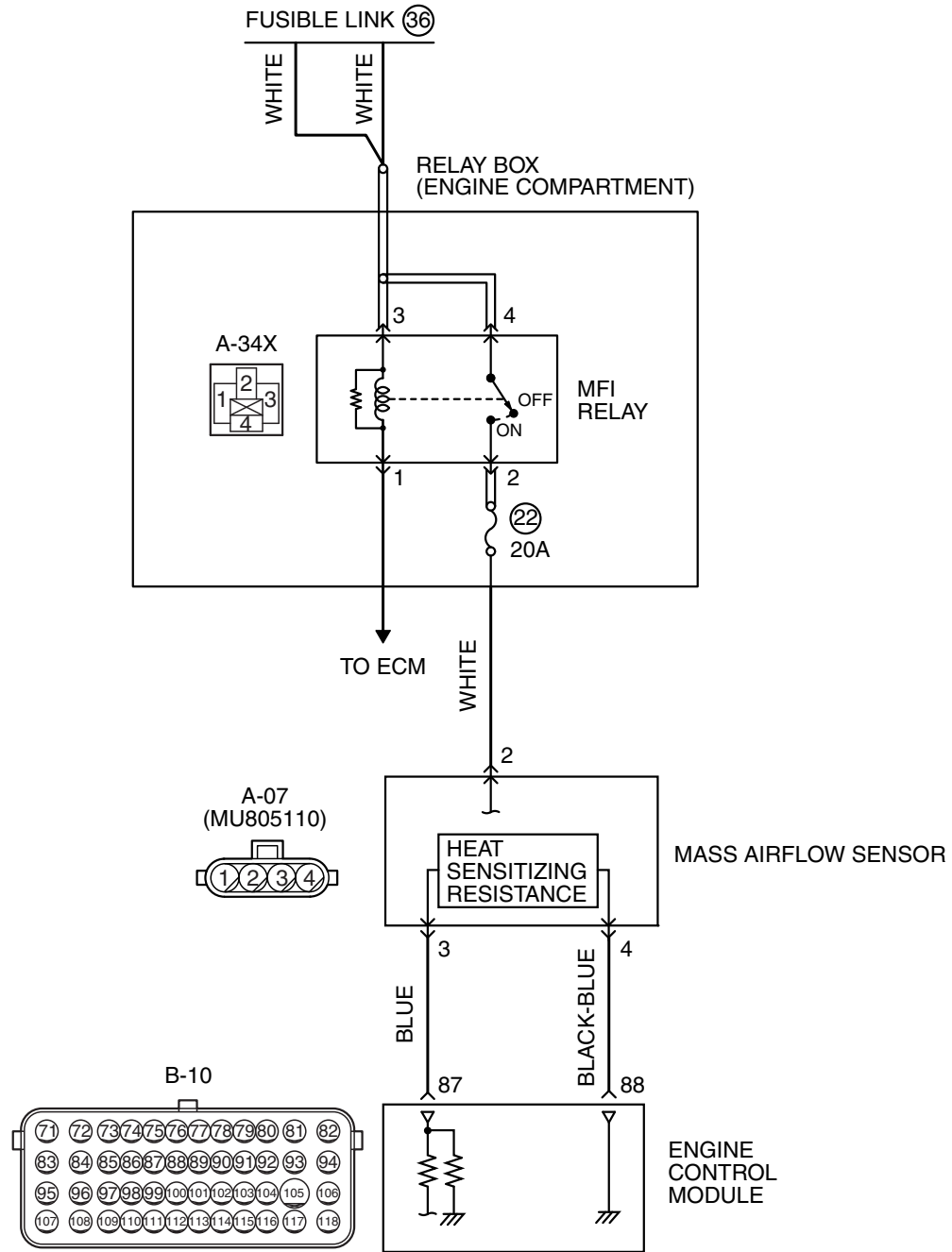

AK704233 AB

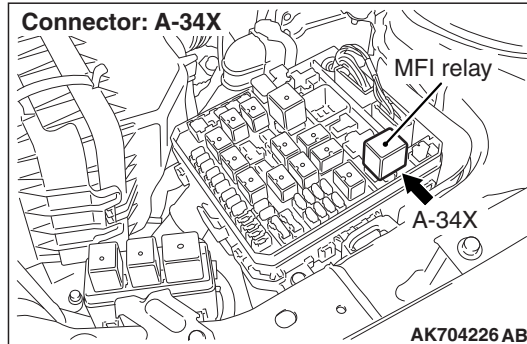
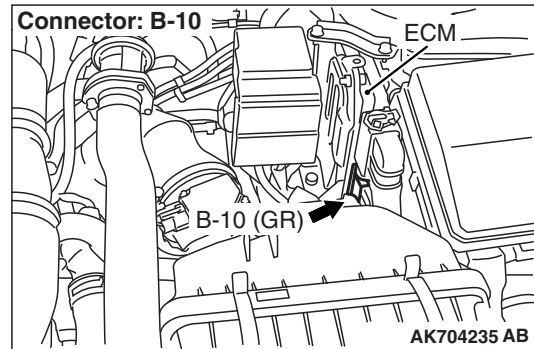
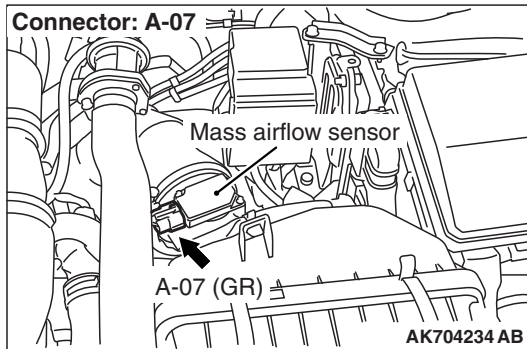

CIRCUIT OPERATION

- The mass airflow sensor power is supplied from the MFI relay (terminal No. 2), and the ground is provided on the ECM (terminal No. 88).
- A voltage that is according to the mass airflow rate is sent to the ECM (terminal No. 87) from the mass airflow sensor output terminal (terminal No. 3).

TECHNICAL DESCRIPTION

- While the engine is running, the mass airflow sensor outputs voltage which corresponds to the mass airflow rate.
- The ECM checks whether the voltage output by the mass airflow sensor while the engine is running is within a specified range.

DESCRIPTIONS OF MONITOR METHODS

Mass airflow sensor output voltage is out of specified range.

MONITOR EXECUTION

Continuous

MONITOR EXECUTION CONDITIONS (Other monitor and Sensor)

Other Monitor (There is no temporary DTC stored in memory for the item monitored below)

- Not applicable

Sensor (The sensor below is determined to be normal)

- Not applicable

DTC SET CONDITIONS

Logic Flow Chart

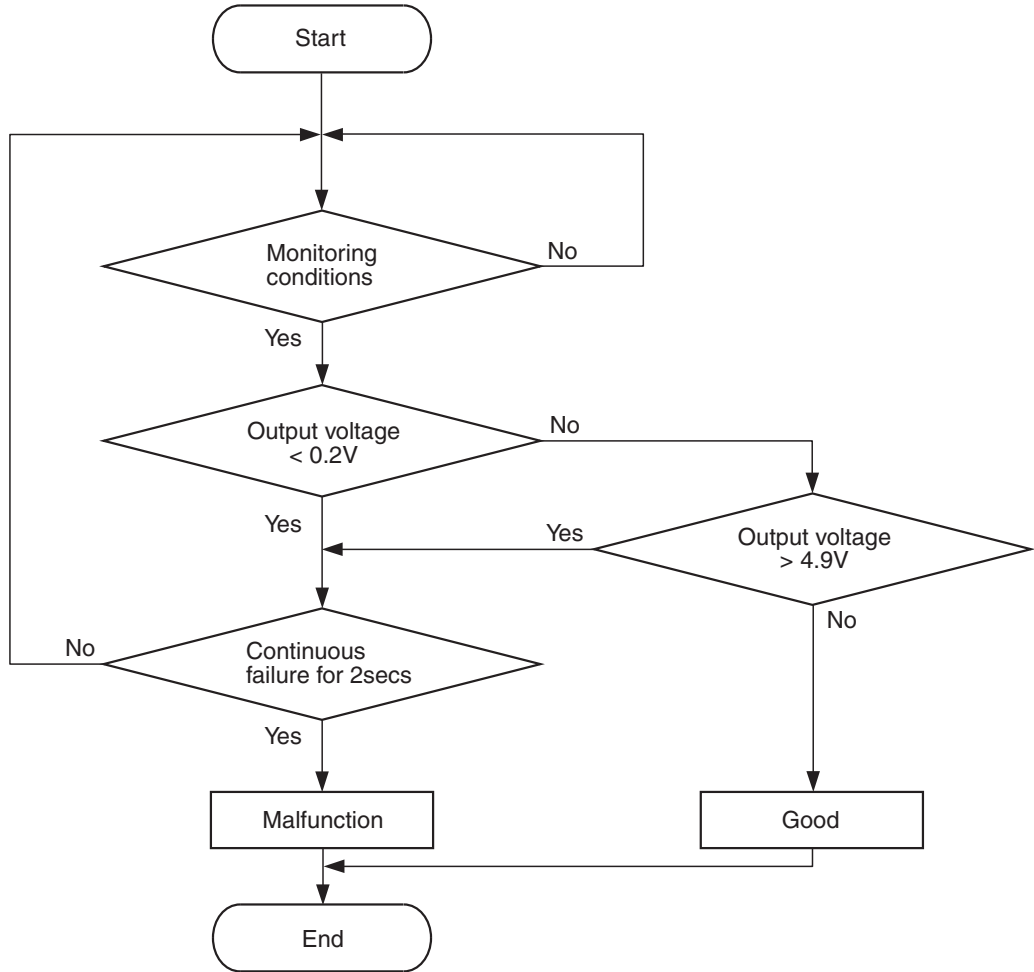

AK604310

Check Condition

- 3 seconds or more have passed since the ignition switch was turned to "ON" position.

Judgement Criterion

- Mass airflow sensor output voltage has continued to be higher than 4.9 volts (corresponding to an air flow rate of 387 g/sec) for 2 seconds.

FAIL-SAFE AND BACKUP FUNCTION

- None

OBD-II DRIVE CYCLE PATTERN

Refer to Diagnostic Function –OBD-II Drive Cycle – Pattern 23 [P.13A-9](#).

TROUBLESHOOTING HINTS (The most likely causes for this code to be set are:)

- Mass airflow sensor failed.
- Open mass airflow sensor circuit, or connector damage.
- ECM failed.

DIAGNOSIS

Required Special Tools:

- MB991958: Scan tool (M.U.T.-III Sub Assembly)
 - MB991824: V.C.I.
 - MB991827: USB Cable
 - MB991910: Main Harness A

STEP 1. Using scan tool MB991958, check data list item 10: Mass Airflow Sensor.

⚠ CAUTION

To prevent damage to scan tool MB991958, always turn the ignition switch to the "LOCK" (OFF) position before connecting or disconnecting scan tool MB991958.

- (1) Connect scan tool MB991958 to the data link connector.
- (2) Start the engine and run at idle.
- (3) Set scan tool MB991958 to the data reading mode for item 10, Mass Airflow Sensor.
- (4) Warm up the engine to normal operating temperature: 80° C to 95° C (176° F to 203° F).
 - The standard value during idling should be between 1,300 and 1,650 millivolts.
 - When the engine is revved, the mass airflow rate should increase according to the increase in engine speed.
- (5) Turn the ignition switch to the "LOCK" (OFF) position.

Q: Is the sensor operating properly?

YES : It can be assumed that this malfunction is intermittent. Refer to GROUP 00, How to Use Troubleshooting/Inspection Service Points –How to Cope with Intermittent Malfunctions P.00-15.

NO : Go to Step 2.

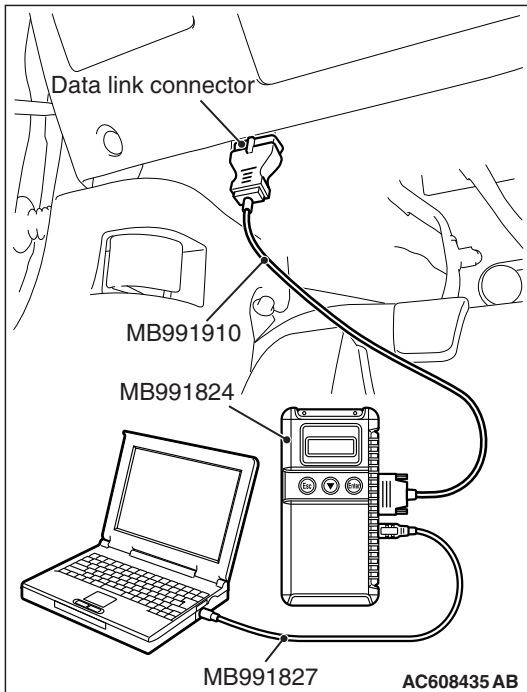

STEP 2. Check harness connector A-07 at mass airflow sensor for damage.

Q: Is the harness connector in good condition?

YES : Go to Step 3.

NO : Repair or replace it. Refer to GROUP 00E, Harness Connector Inspection P.00E-2. Then go to Step 8.

STEP 3. Check the continuity at mass airflow sensor harness side connector A-07.

- (1) Disconnect the connector A-07 and measure at the harness side.
- (2) Check for the continuity between terminal No. 4 and ground.
 - Continuity (2 ohms or less)

Q: Does continuity exist?

YES : Go to Step 7.

NO : Go to Step 4.

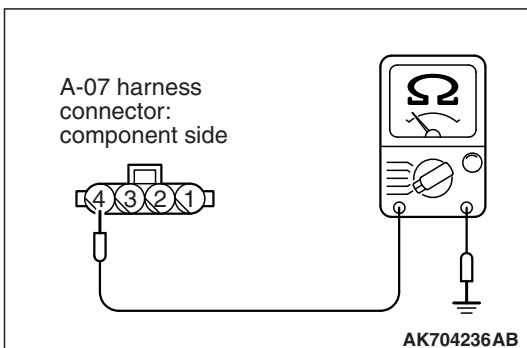

STEP 4. Check harness connector B-10 at ECM for damage.

Q: Is the harness connector in good condition?

YES : Go to Step 5.

NO : Repair or replace it. Refer to GROUP 00E, Harness Connector Inspection [P.00E-2](#). Then go to Step 8.

STEP 5. Check for open circuit between mass airflow sensor connector A-07 (terminal No. 4) and ECM connector B-10 (terminal No. 88).

Q: Is the harness wire in good condition?

YES : Go to Step 6.

NO : Repair it. Then go to Step 8.

STEP 6. Using scan tool MB991958, check data list item 10: Mass Airflow Sensor.

(1) Start the engine and run at idle.

(2) Set scan tool MB991958 to the data reading mode for item 10, Mass Airflow Sensor.

(3) Warm up the engine to normal operating temperature: 80° C to 95° C (176° F to 203° F).

- The standard value during idling should be between 1,300 and 1,650 millivolts.
- When the engine is revved, the mass airflow rate should increase according to the increase in engine speed.

(4) Turn the ignition switch to the "LOCK" (OFF) position.

Q: Is the sensor operating properly?

YES : It can be assumed that this malfunction is intermittent. Refer to GROUP 00, How to Use Troubleshooting/Inspection Service Points –How to Cope with Intermittent Malfunctions [P.00-15](#).

NO : Replace the ECM. When the ECM is replaced, register the ID code. Refer to GROUP 42B, ID Code Registration Necessity Judgment Table <Vehicles with KOS> [P.42B-11](#) or GROUP 42C, ID Codes Registration Judgment Table <Vehicles with WCM> [P.42C-9](#). Then go to Step 8.

STEP 7. Check harness connector B-10 at ECM for damage.

Q: Is the harness connector in good condition?

YES : Replace the mass airflow sensor. Then go to Step 8.

NO : Repair or replace it. Refer to GROUP 00E, Harness Connector Inspection [P.00E-2](#). Then go to Step 8.

STEP 8. Test the OBD-II drive cycle.

- (1) Carry out a test drive with the drive cycle pattern. Refer to Diagnostic Function –OBD-II Drive Cycle –Pattern 23 P.13A-9.
- (2) Check the diagnostic trouble code (DTC).

Q: Is DTC P0103 set?

- YES :** Retry the troubleshooting.
NO : The inspection is complete.

DTC P0106: Manifold Absolute Pressure Circuit Range/Performance Problem

MANIFOLD ABSOLUTE PRESSURE SENSOR CIRCUIT

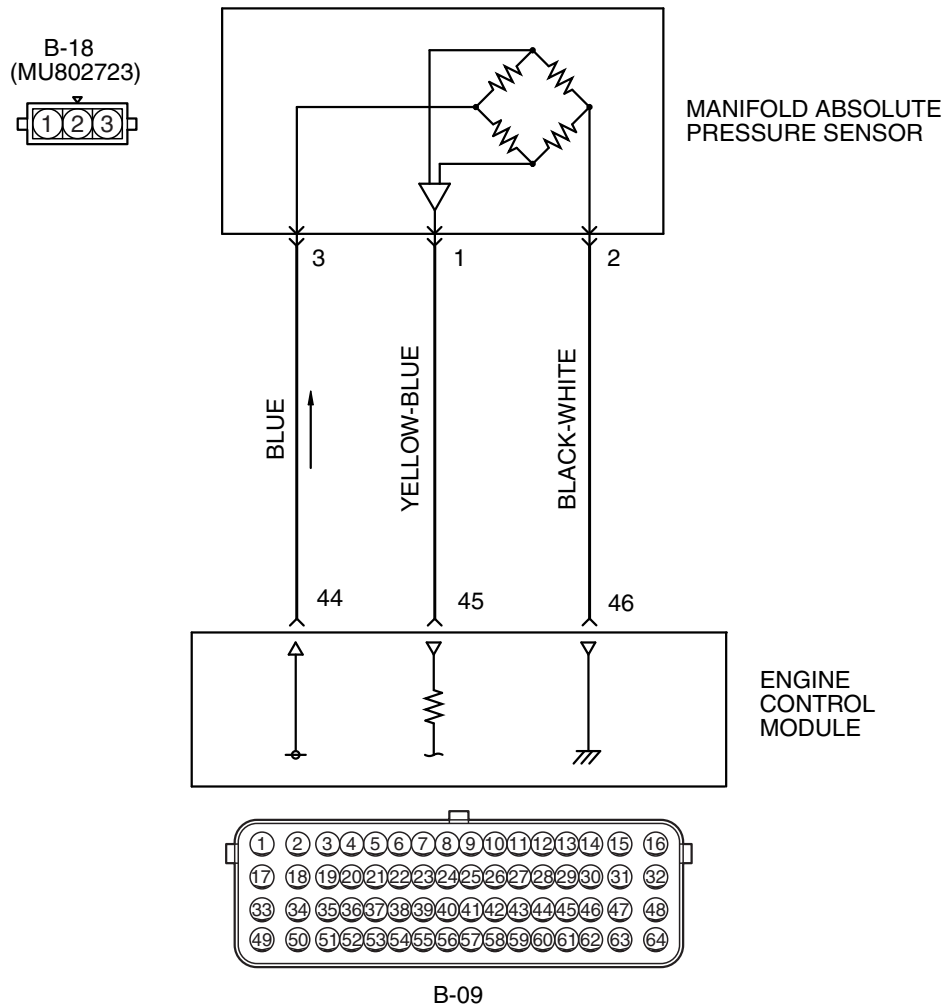

AK604115 AC

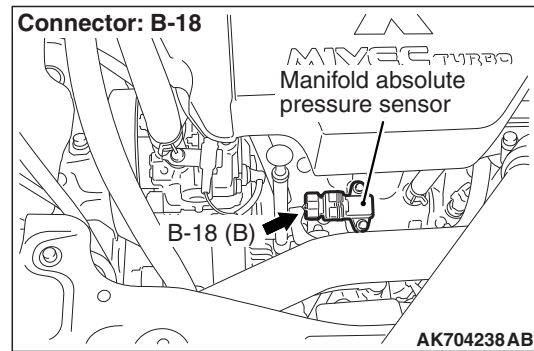
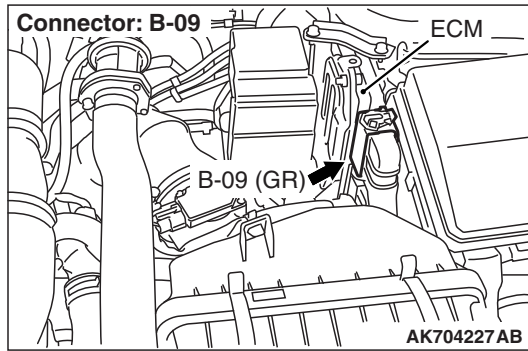

CIRCUIT OPERATION

- A 5-volt voltage is supplied to the manifold absolute pressure sensor power terminal (terminal No. 3) from the ECM (terminal No. 44). The ground terminal (terminal No. 2) is grounded with ECM (terminal No. 46).
- A voltage that is proportional to the intake manifold pressure is sent to the ECM (terminal No. 45) from the manifold absolute pressure sensor output terminal (terminal No. 1).

TECHNICAL DESCRIPTION

- The manifold absolute pressure sensor outputs a voltage which corresponds to the intake manifold pressure.
- The ECM checks whether this voltage is within a specified range.

DESCRIPTIONS OF MONITOR METHODS

Compare load value with manifold absolute pressure sensor output voltage.

MONITOR EXECUTION

Continuous

MONITOR EXECUTION CONDITIONS (Other monitor and Sensor)

Other Monitor (There is no temporary DTC stored in memory for the item monitored below)

- Not applicable

Sensor (The sensor below is determined to be normal)

- Engine coolant temperature sensor
- Throttle position sensor
- Mass airflow sensor
- Intake air temperature sensor
- Barometric pressure sensor

DTC SET CONDITIONS <Range/Performance problem –high input>

Logic Flow Chart

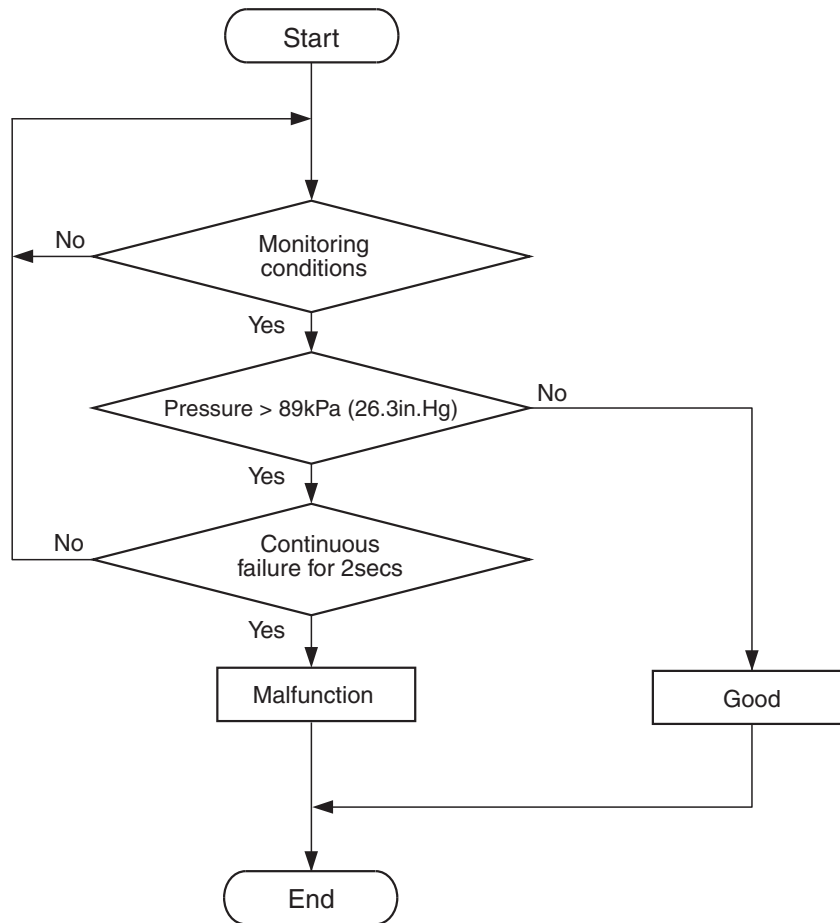

AK604311

Check Conditions

- 8 minutes or more have passed since the engine starting sequence was completed, when the engine coolant temperature at engine start is 0° C (32° F) or lower.
- Engine speed is between 500 r/min and 1,500 r/min.

- Throttle position sensor output voltage is 0.8 volt or lower.

Judgement Criterion

- Manifold absolute pressure sensor output voltage has continued to be 1.3 volts [corresponding to a manifold absolute pressure of 89 kPa (26.3 in.Hg)] or higher for 2 seconds.

DTC SET CONDITIONS <Range/Performance problem –low input>

Logic Flow Chart

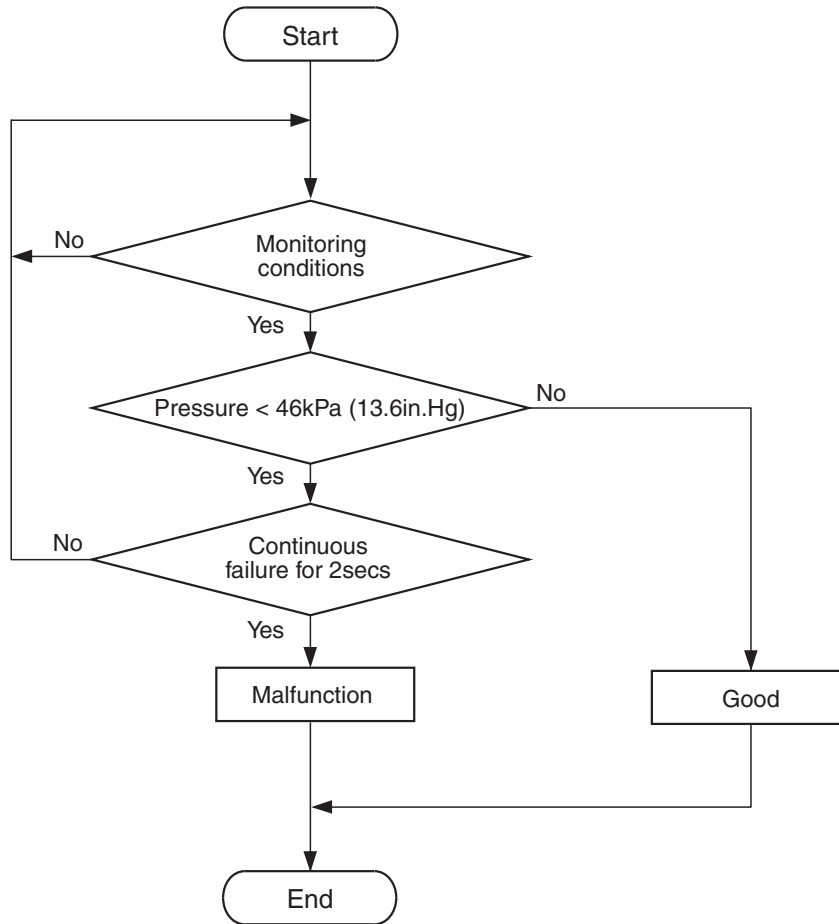

AK800581

Check Conditions

- 8 minutes or more have passed since the engine starting sequence was completed, when the engine coolant temperature at engine start is 0° C (32° F) or lower.
- Engine speed is 1,500 r/min or higher.
- Throttle position sensor output voltage is 3.5 volts or higher.

Judgement Criterion

- Manifold absolute pressure sensor output voltage has continued to be 0.7 volt [corresponding to a manifold absolute pressure of 46 kPa (13.6 in.Hg)] or lower for 2 seconds.

FAIL-SAFE AND BACKUP FUNCTION

- None

OBD-II DRIVE CYCLE PATTERN

Refer to Diagnostic Function –OBD-II Drive Cycle – Pattern 6 [P.13A-9](#).

TROUBLESHOOTING HINTS (The most likely causes for this code to be set are:)

- Manifold absolute pressure sensor failed.
- Harness damage.
- Connector damage.
- ECM failed.

DIAGNOSIS

Required Special Tools:

- MB991958: Scan Tool (M.U.T.-III Sub Assembly)
 - MB991824: V.C.I.
 - MB991827: USB Cable
 - MB991910: Main Harness A
- MB992110: Power Plant ECU Check Harness

STEP 1. Using scan tool MB991958, check data list item 8: Manifold Absolute Pressure Sensor.

CAUTION

To prevent damage to scan tool MB991958, always turn the ignition switch to the "LOCK" (OFF) position before connecting or disconnecting scan tool MB991958.

- (1) Connect scan tool MB991958 to the data link connector.
- (2) Turn the ignition switch to the "ON" position.
- (3) Set scan tool MB991958 to the data reading mode for item 8, Manifold Absolute Pressure Sensor.
 - When altitude is 0 m (0 foot), 101 kPa (29.8 in.Hg).
 - When altitude is 600 m (1,969 feet), 95 kPa (28.1 in.Hg).
 - When altitude is 1,200 m (3,937 feet), 88 kPa (26.0 in.Hg).
 - When altitude is 1,800 m (5,906 feet), 81 kPa (23.9 in.Hg).
- (4) Start the engine.
 - When the engine is idling, 31 –45 kPa (9.1 –13.3 in.Hg).
 - When the engine is suddenly revved, manifold absolute pressure varies.
- (5) Turn the ignition switch to the "LOCK" (OFF) position.

Q: Is the sensor operating properly?

YES : It can be assumed that this malfunction is intermittent. Refer to GROUP 00, How to Use Troubleshooting/Inspection Service Points –How to Cope with Intermittent Malfunctions [P.00-15](#).

NO : Go to Step 2.

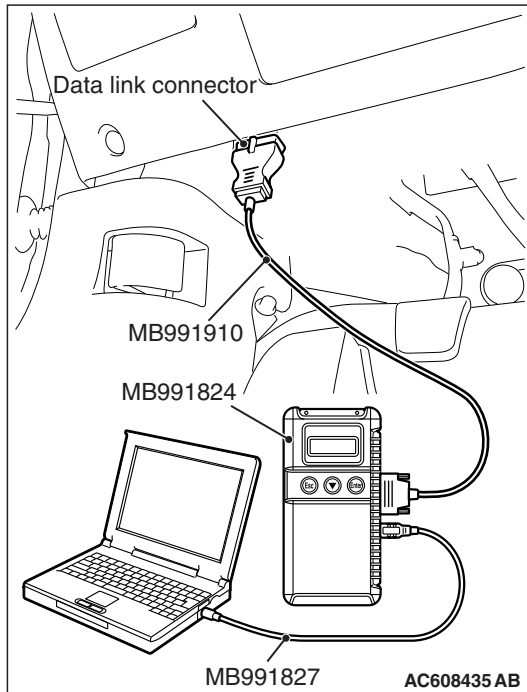

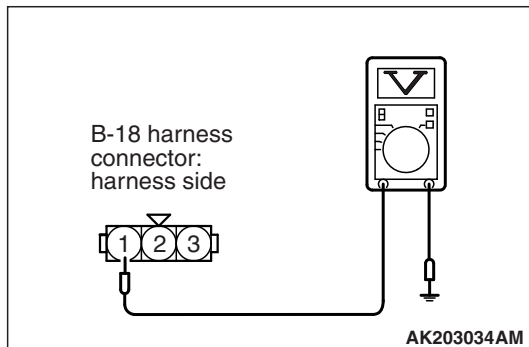

STEP 2. Measure the sensor output voltage at manifold absolute pressure sensor connector B-18 by backprobing.

- (1) Do not disconnect the connector B-18.
- (2) Turn the ignition switch to the "ON" position.
- (3) Measure the voltage between terminal No. 1 and ground by backprobing.
 - When altitude is 0 m (0 foot), voltage should be between 1.2 and 1.8 volts.
 - When altitude is 600 m (1,969 feet), voltage should be between 1.1 and 1.7 volts.
 - When altitude is 1,200 m (3,937 feet), voltage should be between 1.0 and 1.6 volts.
 - When altitude is 1,800 m (5,906 feet), voltage should be between 0.9 and 1.5 volts.
- (4) Turn the ignition switch to the "LOCK" (OFF) position.

Q: Is the measured voltage normal?

- YES** : Go to Step 10.
NO : Go to Step 3.

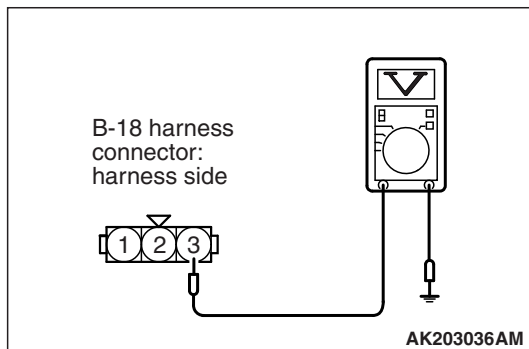

STEP 3. Measure the sensor supply voltage at manifold absolute pressure sensor connector B-18 by backprobing.

- (1) Do not disconnect the connector B-18.
- (2) Turn the ignition switch to the "ON" position.
- (3) Measure the voltage between terminal No. 3 and ground by backprobing.
 - Voltage should be between 4.9 and 5.1 volts.
- (4) Turn the ignition switch to the "LOCK" (OFF) position.

Q: Is the measured voltage between 4.9 and 5.1 volts?

- YES** : Go to Step 6.
NO : Go to Step 4.

STEP 4. Check harness connector B-18 at the manifold absolute pressure sensor and harness connector B-09 at ECM for damage.

Q: Is the harness connector in good condition?

- YES** : Go to step 5.
NO : Repair or replace it. Refer to GROUP 00E, Harness Connector Inspection [P.00E-2](#). Then go to Step 13.

STEP 5. Check for harness damage between manifold absolute pressure sensor connector B-18 (terminal No. 3) and ECM connector B-09 (terminal No. 44).

Q: Is the harness wire in good condition?

- YES** : Go to Step 12.
NO : Repair it. Then go to Step 13.

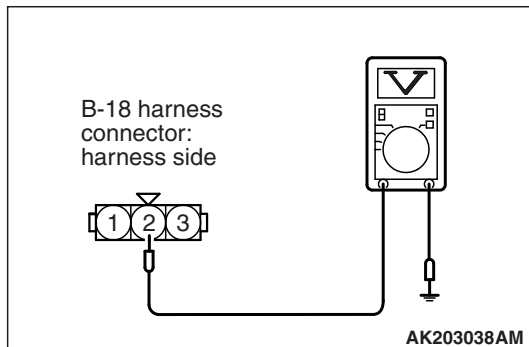

STEP 6. Measure the ground voltage at manifold absolute pressure sensor connector B-18 by backprobing.

- (1) Do not disconnect the connector B-18.
- (2) Turn the ignition switch to the "ON" position.
- (3) Measure the voltage between terminal No. 2 and ground by backprobing.
 - Voltage should be 0.5 volt or less.
- (4) Turn the ignition switch to the "LOCK" (OFF) position.

Q: Is the measured voltage 0.5 volt or less?

YES : Go to Step 9.

NO : Go to Step 7.

STEP 7. Check harness connector B-18 at the manifold absolute pressure sensor and harness connector B-09 at ECM for damage.

Q: Is the harness connector in good condition?

YES : Go to Step 8.

NO : Repair or replace it. Refer to GROUP 00E, Harness Connector Inspection [P.00E-2](#). Then go to Step 13.

STEP 8. Check for harness damage between manifold absolute pressure sensor connector B-18 (terminal No. 2) and ECM connector B-09 (terminal No. 46).

Q: Is the harness wire in good condition?

YES : Go to Step 12.

NO : Repair it. Then go to Step 13.

STEP 9. Check harness connector B-18 at manifold absolute pressure sensor for damage.

Q: Is the harness connector in good condition?

YES : Replace the manifold absolute pressure sensor. Then go to Step 13.

NO : Repair or replace it. Refer to GROUP 00E, Harness Connector Inspection [P.00E-2](#). Then go to Step 13.

STEP 10. Check harness connector B-18 at the manifold absolute pressure sensor and harness connector B-09 at ECM for damage.

Q: Is the harness connector in good condition?

YES : Go to Step 11.

NO : Repair or replace it. Refer to GROUP 00E, Harness Connector Inspection [P.00E-2](#). Then go to Step 13.

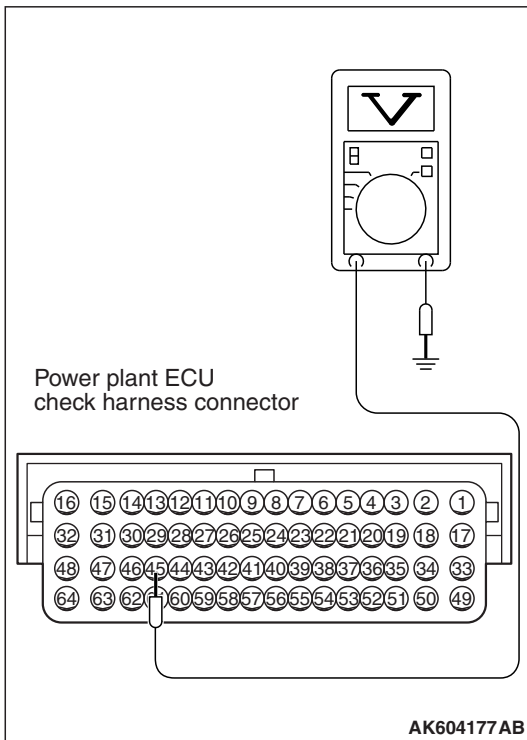
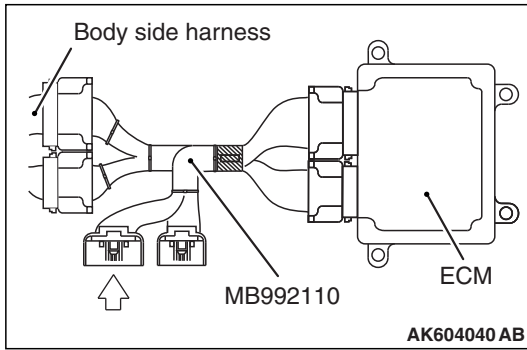

STEP 11. Measure the sensor output voltage at ECM connector B-09 by using power plant ECU check harness special tool MB992110.

(1) Disconnect all ECM connectors. Connect the power plant ECU check harness special tool MB992110 between the separated connectors.

(2) Turn the ignition switch to the "ON" position.

- (3) Measure the voltage between terminal No. 45 and ground.
- When altitude is 0 m (0 foot), voltage should be between 1.2 and 1.8 volts.
 - When altitude is 600 m (1,969 feet), voltage should be between 1.1 and 1.7 volts.
 - When altitude is 1,200 m (3,937 feet), voltage should be between 1.0 and 1.6 volts.
 - When altitude is 1,800 m (5,906 feet), voltage should be between 0.9 and 1.5 volts.

(4) Turn the ignition switch to the "LOCK" (OFF) position.

Q: Is the measured voltage normal?

YES : Go to Step 12.

NO : Repair harness wire between manifold absolute pressure sensor connector B-18 (terminal No. 1) and ECM connector B-09 (terminal No. 45) because of harness damage. Then go to Step 13.

STEP 12. Using scan tool MB991958, check data list item 8: Manifold Absolute Pressure Sensor.

- (1) Turn the ignition switch to the "ON" position.
- (2) Set scan tool MB991958 to the data reading mode for item 8, Manifold Absolute Pressure Sensor.
 - When altitude is 0 m (0 foot), 101 kPa (29.8 in.Hg).
 - When altitude is 600 m (1,969 feet), 95 kPa (28.1 in.Hg).
 - When altitude is 1,200 m (3,937 feet), 88 kPa (26.0 in.Hg).
 - When altitude is 1,800 m (5,906 feet), 81 kPa (23.9 in.Hg).
- (3) Start the engine.
 - When the engine is idling, 31 –45 kPa (9.1 –13.3 in.Hg).
 - When the engine is suddenly revved, manifold absolute pressure varies.
- (4) Turn the ignition switch to the "LOCK" (OFF) position.

Q: Is the sensor operating properly?

YES : It can be assumed that this malfunction is intermittent. Refer to GROUP 00, How to Use Troubleshooting/Inspection Service Points –How to Cope with Intermittent Malfunctions [P.00-15](#).

NO : Replace the ECM. When the ECM is replaced, register the ID code. Refer to GROUP 42B, ID Code Registration Necessity Judgment Table <Vehicles with KOS> [P.42B-11](#) or GROUP 42C, ID Codes Registration Judgment Table <Vehicles with WCM> [P.42C-9](#). Then go to Step 13.

STEP 13. Test the OBD-II drive cycle.

- (1) Carry out a test drive with the drive cycle pattern. Refer to Diagnostic Function –OBD-II Drive Cycle –Pattern 6 [P.13A-9](#).
- (2) Check the diagnostic trouble code (DTC).

Q: Is DTC P0106 set?

YES : Retry the troubleshooting.

NO : The inspection is complete.

DTC P0107: Manifold Absolute Pressure Circuit Low Input

MANIFOLD ABSOLUTE PRESSURE SENSOR CIRCUIT

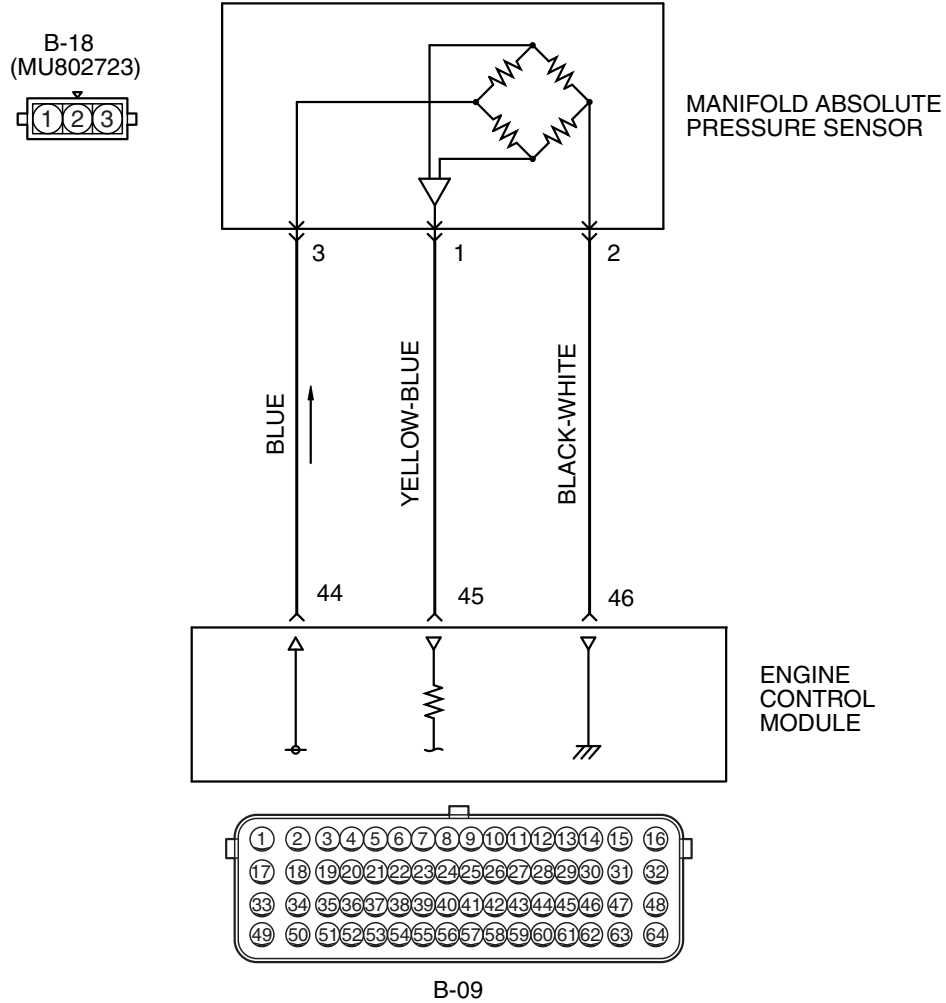

AK604115 AC

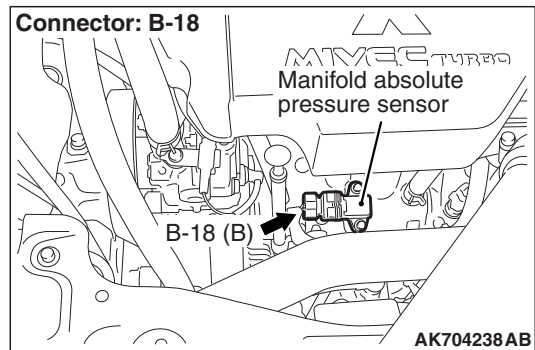
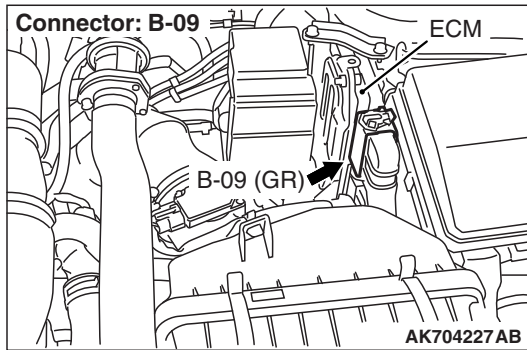

CIRCUIT OPERATION

- A 5-volt voltage is supplied to the manifold absolute pressure sensor power terminal (terminal No. 3) from the ECM (terminal No. 44). The ground terminal (terminal No. 2) is grounded with ECM (terminal No. 46).
- A voltage that is proportional to the intake manifold pressure is sent to the ECM (terminal No. 45) from the manifold absolute pressure sensor output terminal (terminal No. 1).

TECHNICAL DESCRIPTION

- The manifold absolute pressure sensor outputs a voltage which corresponds to the intake manifold pressure.
- The ECM checks whether this voltage is within a specified range.

DESCRIPTIONS OF MONITOR METHODS

Manifold absolute pressure sensor output voltage is out of specified range.

MONITOR EXECUTION

Continuous

MONITOR EXECUTION CONDITIONS (Other monitor and Sensor)

Other Monitor (There is no temporary DTC stored in memory for the item monitored below)

- Not applicable

Sensor (The sensor below is determined to be normal)

- Engine coolant temperature sensor
- Throttle position sensor
- Mass airflow sensor
- Intake air temperature sensor
- Barometric pressure sensor

DTC SET CONDITIONS

Logic Flow Chart

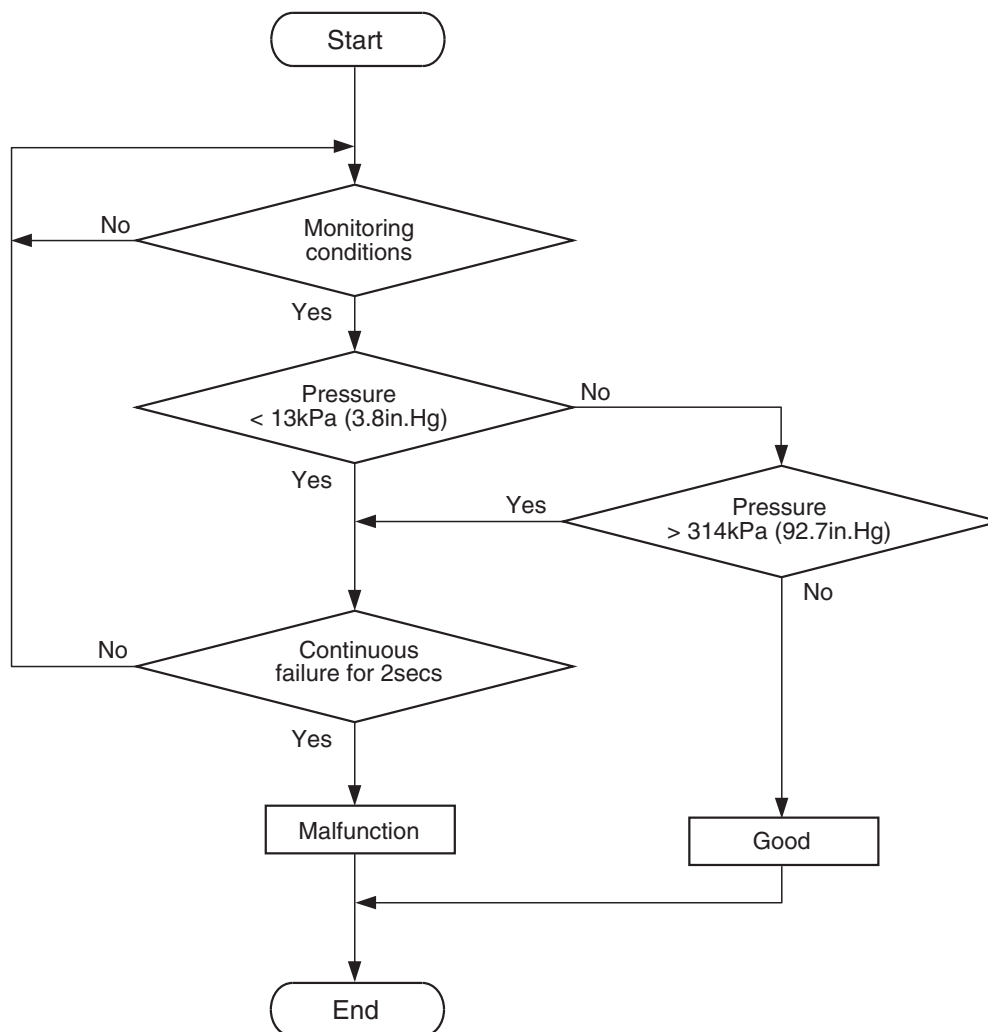

AK800582

Check Conditions

- 8 minutes or more have passed since the engine starting sequence was completed, when the engine coolant temperature at engine start is 0° C (32° F) or lower.
- Volumetric efficiency is 20 percent or higher.

Judgement Criterion

- Manifold absolute pressure sensor output voltage has continued to be 0.2 volt [corresponding to a manifold absolute pressure of 13 kPa (3.8 in.Hg)] or lower for 2 seconds.

FAIL-SAFE AND BACKUP FUNCTION

- None

OBD-II DRIVE CYCLE PATTERN

Refer to Diagnostic Function –OBD-II Drive Cycle – Pattern 6 [P.13A-9](#).

TROUBLESHOOTING HINTS (The most likely causes for this code to be set are:)

- Manifold absolute pressure sensor failed.
- Open or shorted manifold absolute pressure sensor circuit, harness damage or connector damage.
- ECM failed.

DIAGNOSIS

Required Special Tools:

- MB991958: Scan Tool (M.U.T.-III Sub Assembly)
 - MB991824: V.C.I.
 - MB991827: USB Cable
 - MB991910: Main Harness A
- MB992110: Power Plant ECU Check Harness

STEP 1. Using scan tool MB991958, check data list item 8: Manifold Absolute Pressure Sensor.

CAUTION

To prevent damage to scan tool MB991958, always turn the ignition switch to the "LOCK" (OFF) position before connecting or disconnecting scan tool MB991958.

- (1) Connect scan tool MB991958 to the data link connector.
- (2) Turn the ignition switch to the "ON" position.
- (3) Set scan tool MB991958 to the data reading mode for item 8, Manifold Absolute Pressure Sensor.
 - When altitude is 0 m (0 foot), 101 kPa (29.8 in.Hg).
 - When altitude is 600 m (1,969 feet), 95 kPa (28.1 in.Hg).
 - When altitude is 1,200 m (3,937 feet), 88 kPa (26.0 in.Hg).
 - When altitude is 1,800 m (5,906 feet), 81 kPa (23.9 in.Hg).
- (4) Start the engine.
 - When the engine is idling, 31 –45 kPa (9.1 –13.3 in.Hg).
 - When the engine is suddenly revved, manifold absolute pressure varies.
- (5) Turn the ignition switch to the "LOCK" (OFF) position.

Q: Is the sensor operating properly?

YES : It can be assumed that this malfunction is intermittent. Refer to GROUP 00, How to Use Troubleshooting/Inspection Service Points –How to Cope with Intermittent Malfunctions P.00-15.

NO : Go to Step 2.

STEP 2. Measure the sensor supply voltage at manifold absolute pressure sensor connector B-18 by backprobing.

- (1) Do not disconnect the connector B-18.
- (2) Turn the ignition switch to the "ON" position.
- (3) Measure the voltage between terminal No. 3 and ground by backprobing.
 - Voltage should be between 4.9 and 5.1 volts.
- (4) Turn the ignition switch to the "LOCK" (OFF) position.

Q: Is the measured voltage between 4.9 and 5.1 volts?

YES : Go to Step 8.

NO : Go to Step 3.

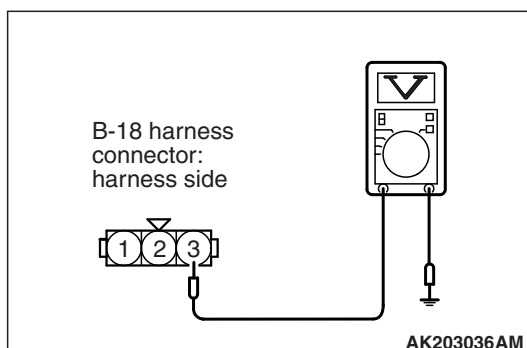
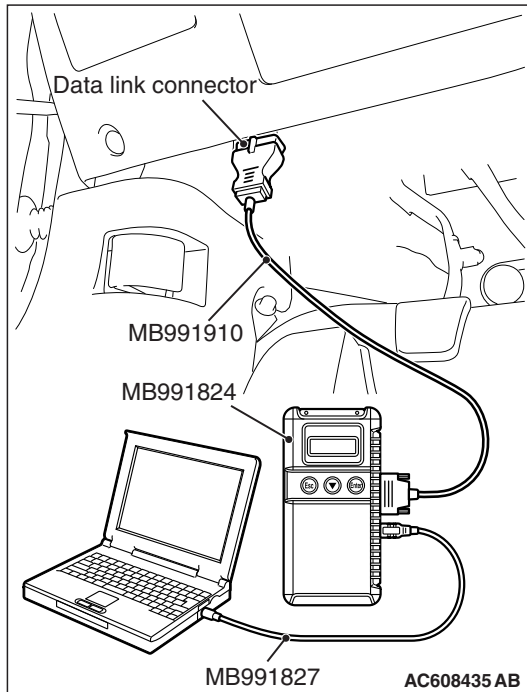

STEP 3. Check harness connector B-09 at ECM for damage.

Q: Is the harness connector in good condition?

YES : Go to Step 4.

NO : Repair or replace it. Refer to GROUP 00E, Harness Connector Inspection [P.00E-2](#). Then go to Step 12.

STEP 4. Measure the sensor supply voltage at ECM connector B-09 by using power plant ECU check harness special tool MB992110.

(1) Disconnect all ECM connectors. Connect the power plant ECU check harness special tool MB992110 between the separated connectors.

(2) Turn the ignition switch to the "ON" position.

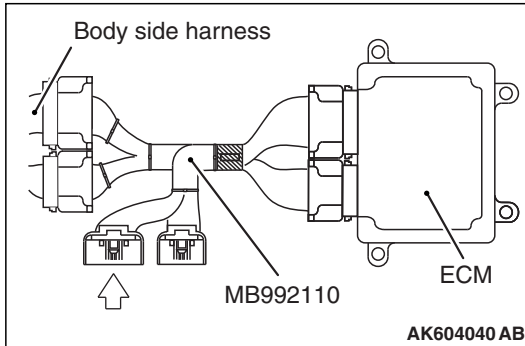

(3) Measure the voltage between terminal No. 44 and ground.

- Voltage should be between 4.9 and 5.1 volts.

(4) Turn the ignition switch to the "LOCK" (OFF) position.

Q: Is the measured voltage between 4.9 and 5.1 volts?

YES : Go to Step 7.

NO : Go to Step 5.

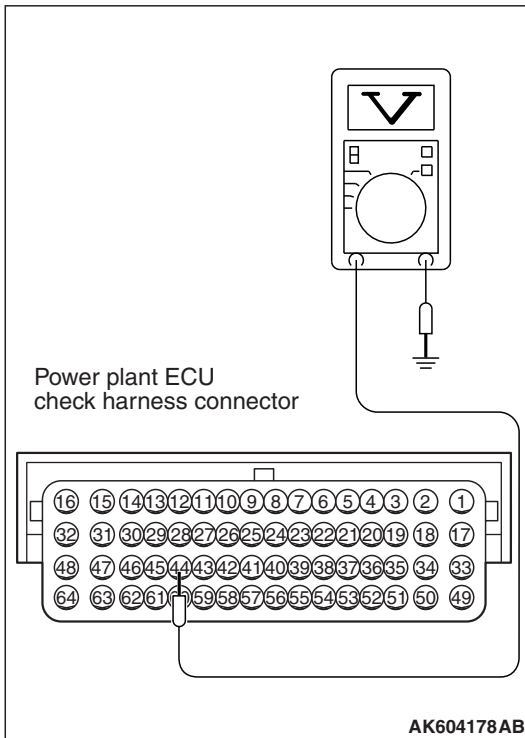

STEP 5. Check harness connector B-18 at the manifold absolute pressure sensor for damage.

Q: Is the harness connector in good condition?

YES : Go to Step 6.

NO : Repair or replace it. Refer to GROUP 00E, Harness Connector Inspection [P.00E-2](#). Then go to Step 12.

STEP 6. Check for short circuit to ground between manifold absolute pressure sensor connector B-18 (terminal No. 3) and ECM connector B-09 (terminal No. 44).

Q: Is the harness wire in good condition?

YES : Go to Step 11.

NO : Repair it. Then go to Step 12.

STEP 7. Check harness connector B-18 at the manifold absolute pressure sensor for damage.

Q: Is the harness connector in good condition?

YES : Repair harness wire between manifold absolute pressure sensor connector B-18 (terminal No. 3) and ECM connector B-09 (terminal No. 44) because of open circuit. Then go to Step 12.

NO : Repair or replace it. Refer to GROUP 00E, Harness Connector Inspection [P.00E-2](#). Then go to Step 12.

STEP 8. Check harness connector B-18 at the manifold absolute pressure sensor and harness connector B-09 at ECM for damage.

Q: Is the harness connector in good condition?

YES : Go to Step 9.

NO : Repair or replace it. Refer to GROUP 00E, Harness Connector Inspection [P.00E-2](#). Then go to Step 12.

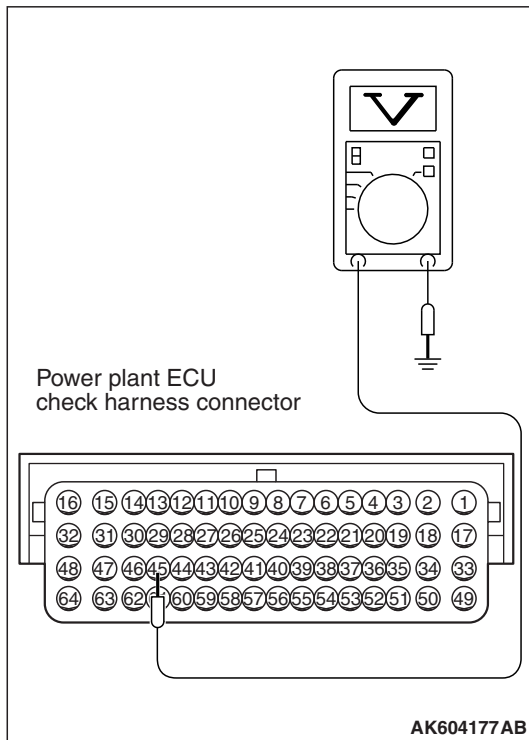
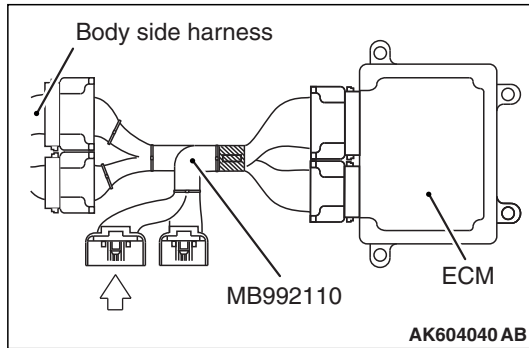

STEP 9. Measure the sensor output voltage at ECM connector B-09 by using power plant ECU check harness special tool MB992110.

(1) Disconnect all ECM connectors. Connect the power plant ECU check harness special tool MB992110 between the separated connectors.

(2) Turn the ignition switch to the "ON" position.

- (3) Measure the voltage between terminal No. 45 and ground.
- When altitude is 0 m (0 foot), voltage should be between 1.2 and 1.8 volts.
 - When altitude is 600 m (1,969 feet), voltage should be between 1.1 and 1.7 volts.
 - When altitude is 1,200 m (3,937 feet), voltage should be between 1.0 and 1.6 volts.
 - When altitude is 1,800 m (5,906 feet), voltage should be between 0.9 and 1.5 volts.

(4) Turn the ignition switch to the "LOCK" (OFF) position.

Q: Is the measured voltage normal?

YES : Go to Step 11.

NO : Go to Step 10.

STEP 10. Check for open circuit and short circuit to ground between manifold absolute pressure sensor connector B-18 (terminal No. 1) and ECM connector B-09 (terminal No. 45).

Q: Is the harness wire in good condition?

YES : Replace the manifold absolute pressure sensor. Then go to Step 12.

NO : Repair it. Then go to Step 12.

STEP 11. Using scan tool MB991958, check data list item 8: Manifold Absolute Pressure Sensor.

- (1) Turn the ignition switch to the "ON" position.
- (2) Set scan tool MB991958 to the data reading mode for item 8, Manifold Absolute Pressure Sensor.
 - When altitude is 0 m (0 foot), 101 kPa (29.8 in.Hg).
 - When altitude is 600 m (1,969 feet), 95 kPa (28.1 in.Hg).
 - When altitude is 1,200 m (3,937 feet), 88 kPa (26.0 in.Hg).
 - When altitude is 1,800 m (5,906 feet), 81 kPa (23.9 in.Hg).
- (3) Start the engine.
 - When the engine is idling, 31 –45 kPa (9.1 –13.3 in.Hg).
 - When the engine is suddenly revved, manifold absolute pressure varies.
- (4) Turn the ignition switch to the "LOCK" (OFF) position.

Q: Is the sensor operating properly?

- YES** : It can be assumed that this malfunction is intermittent. Refer to GROUP 00, How to Use Troubleshooting/Inspection Service Points –How to Cope with Intermittent Malfunctions [P.00-15](#).
- NO** : Replace the ECM. When the ECM is replaced, register the ID code. Refer to GROUP 42B, ID Code Registration Necessity Judgment Table <Vehicles with KOS> [P.42B-11](#) or GROUP 42C, ID Codes Registration Judgment Table <Vehicles with WCM> [P.42C-9](#). Then go to Step 12.

STEP 12. Test the OBD-II drive cycle.

- (1) Carry out a test drive with the drive cycle pattern. Refer to Diagnostic Function –OBD-II Drive Cycle –Pattern 6 [P.13A-9](#).
- (2) Check the diagnostic trouble code (DTC).

Q: Is DTC P0107 set?

- YES** : Retry the troubleshooting.
- NO** : The inspection is complete.

DTC P0108: Manifold Absolute Pressure Circuit High Input

MANIFOLD ABSOLUTE PRESSURE SENSOR CIRCUIT

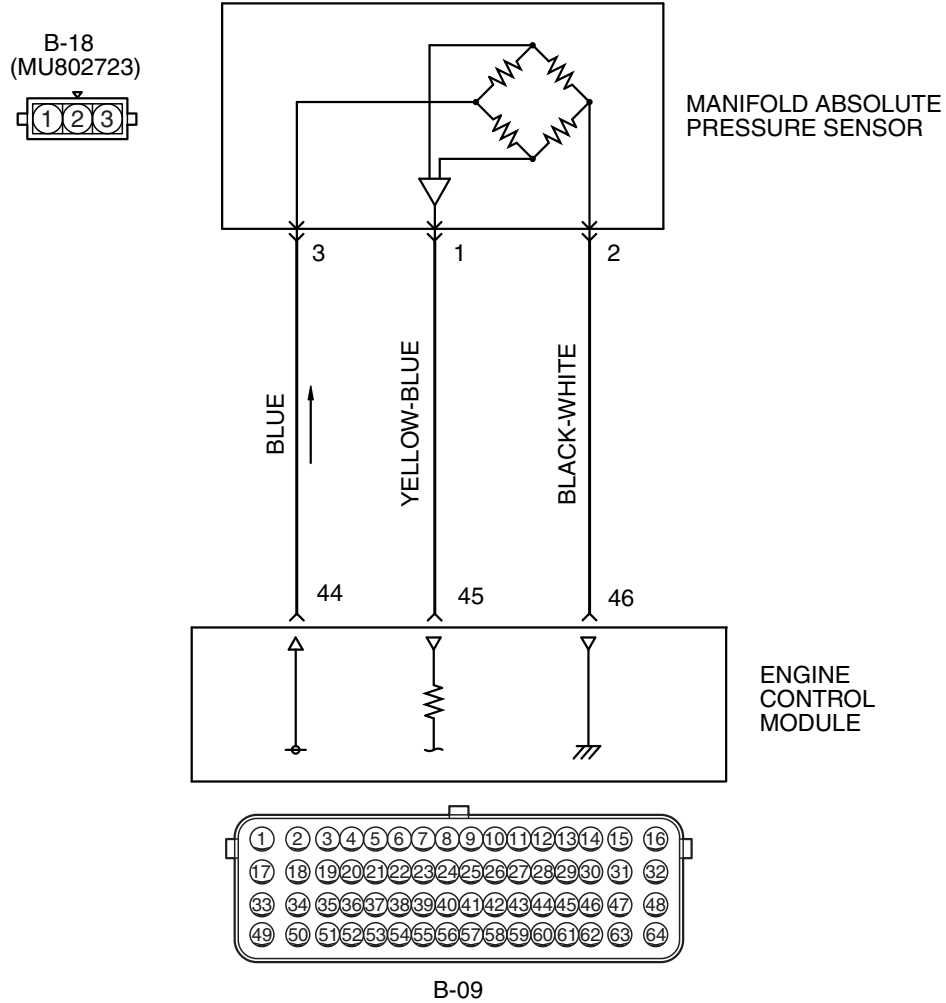

AK604115 AC

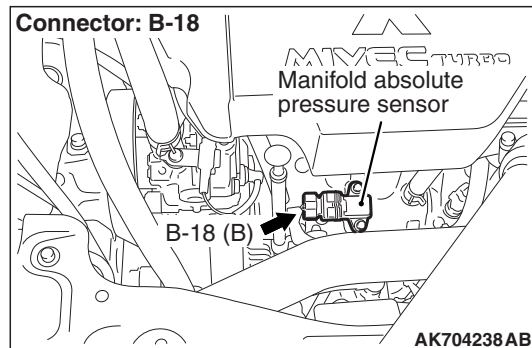
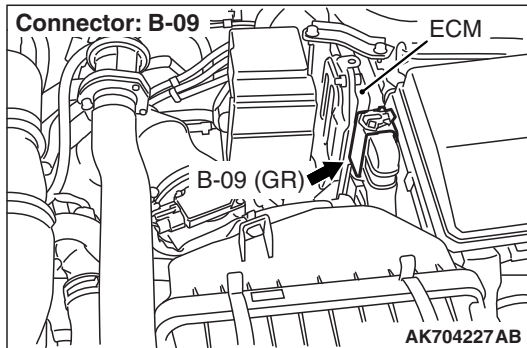

CIRCUIT OPERATION

- A 5-volt voltage is supplied to the manifold absolute pressure sensor power terminal (terminal No. 3) from ECM (terminal No. 44). The ground terminal (terminal No. 2) is grounded with ECM (terminal No. 46).
- A voltage that is proportional to the intake manifold pressure is sent to the ECM (terminal No. 45) from the manifold absolute pressure sensor output terminal (terminal No. 1).

TECHNICAL DESCRIPTION

- The manifold absolute pressure sensor outputs a voltage which corresponds to the intake manifold pressure.
- The ECM checks whether this voltage is within a specified range.

DESCRIPTIONS OF MONITOR METHODS

Manifold absolute pressure sensor output voltage is out of specified range.

MONITOR EXECUTION

Continuous

MONITOR EXECUTION CONDITIONS (Other monitor and Sensor)

Other Monitor (There is no temporary DTC stored in memory for the item monitored below)

- Not applicable

Sensor (The sensor below is determined to be normal)

- Engine coolant temperature sensor
- Throttle position sensor
- Mass airflow sensor
- Intake air temperature sensor
- Barometric pressure sensor

DTC SET CONDITIONS

Logic Flow Chart

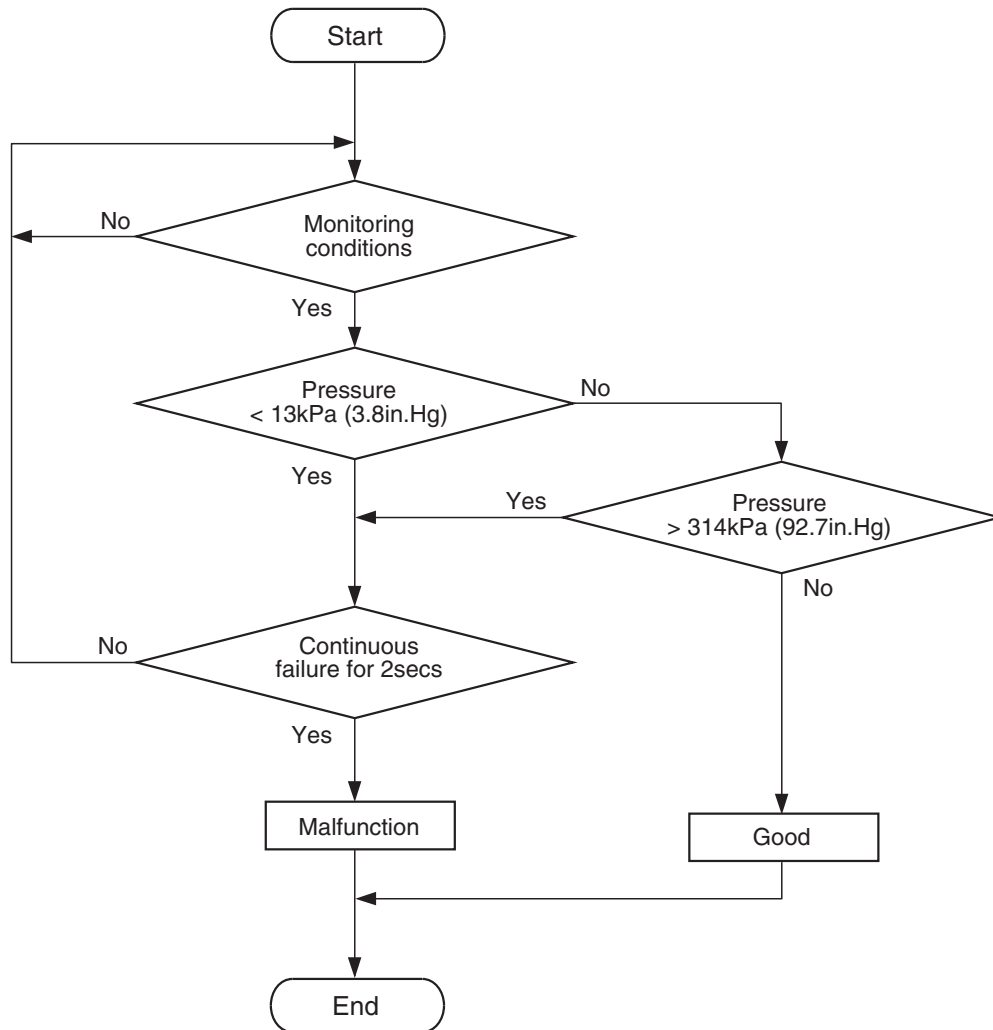

AK800582

Check Condition

- 8 minutes or more have passed since the engine starting sequence was completed, when the engine coolant temperature at engine start is 0° C (32° F) or lower.

Judgement Criterion

- Manifold absolute pressure sensor output voltage has continued to be 4.6 volts [corresponding to a manifold absolute pressure of 314 kPa (92.7 in.Hg)] or higher for 2 seconds.

FAIL-SAFE AND BACKUP FUNCTION

- None

OBD-II DRIVE CYCLE PATTERN

Refer to Diagnostic Function –OBD-II Drive Cycle – Pattern 23 [P.13A-9](#).

TROUBLESHOOTING HINTS (The most likely causes for this code to be set are:)

- Manifold absolute pressure sensor failed.
- Open manifold absolute pressure sensor circuit, or connector damage.
- ECM failed.

DIAGNOSIS

Required Special Tools:

- MB991958: Scan Tool (M.U.T.-III Sub Assembly)
 - MB991824: V.C.I.
 - MB991827: USB Cable
 - MB991910: Main Harness A

STEP 1. Using scan tool MB991958, check data list item 8: Manifold Absolute Pressure Sensor.

⚠ CAUTION

To prevent damage to scan tool MB991958, always turn the ignition switch to the "LOCK" (OFF) position before connecting or disconnecting scan tool MB991958.

- (1) Connect scan tool MB991958 to the data link connector.
- (2) Turn the ignition switch to the "ON" position.
- (3) Set scan tool MB991958 to the data reading mode for item 8, Manifold Absolute Pressure Sensor.
 - When altitude is 0 m (0 foot), 101 kPa (29.8 in.Hg).
 - When altitude is 600 m (1,969 feet), 95 kPa (28.1 in.Hg).
 - When altitude is 1,200 m (3,937 feet), 88 kPa (26.0 in.Hg).
 - When altitude is 1,800 m (5,906 feet), 81 kPa (23.9 in.Hg).
- (4) Start the engine.
 - When the engine is idling, 31 –45 kPa (9.1 –13.3 in.Hg).
 - When the engine is suddenly revved, manifold absolute pressure varies.
- (5) Turn the ignition switch to the "LOCK" (OFF) position.

Q: Is the sensor operating properly?

YES : It can be assumed that this malfunction is intermittent. Refer to GROUP 00, How to Use Troubleshooting/Inspection Service Points –How to Cope with Intermittent Malfunctions P.00-15.

NO : Go to Step 2.

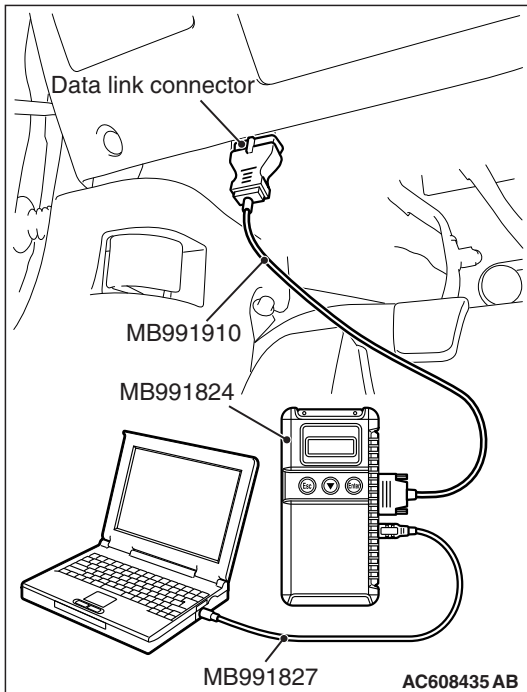

STEP 2. Measure the ground voltage at manifold absolute pressure sensor connector B-18 by backprobing.

- (1) Do not disconnect the connector B-18.
- (2) Turn the ignition switch to the "ON" position.
- (3) Measure the voltage between terminal No. 2 and ground by backprobing.
 - Voltage should be 0.5 volt or less.
- (4) Turn the ignition switch to the "LOCK" (OFF) position.

Q: Is the measured voltage 0.5 volt or less?

YES : Go to Step 6.

NO : Go to Step 3.

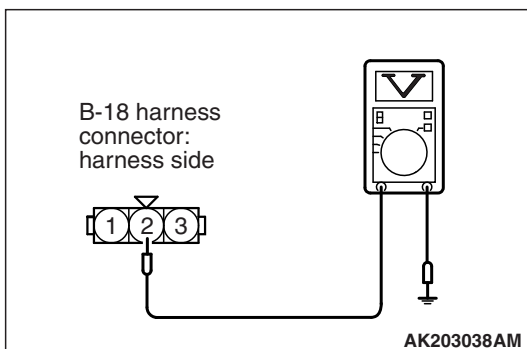

STEP 3. Check harness connector B-18 at the manifold absolute pressure sensor and harness connector B-09 at ECM for damage.

Q: Is the harness connector in good condition?

YES : Go to Step 4.

NO : Repair or replace it. Refer to GROUP 00E, Harness Connector Inspection [P.00E-2](#). Then go to Step 7.

STEP 4. Check for open circuit between manifold absolute pressure sensor connector B-18 (terminal No. 2) and ECM connector B-09 (terminal No. 46).

Q: Is the harness wire in good condition?

YES : Go to Step 5.

NO : Repair it. Then go to Step 7.

STEP 5. Using scan tool MB991958, check data list item 8: Manifold Absolute Pressure Sensor.

(1) Turn the ignition switch to the "ON" position.

(2) Set scan tool MB991958 to the data reading mode for item 8, Manifold Absolute Pressure Sensor.

- When altitude is 0 m (0 foot), 101 kPa (29.8 in.Hg).
- When altitude is 600 m (1,969 feet), 95 kPa (28.1 in.Hg).
- When altitude is 1,200 m (3,937 feet), 88 kPa (26.0 in.Hg).
- When altitude is 1,800 m (5,906 feet), 81 kPa (23.9 in.Hg).

(3) Start the engine.

- When the engine is idling, 31 –45 kPa (9.1 –13.3 in.Hg).
- When the engine is suddenly revved, manifold absolute pressure varies.

(4) Turn the ignition switch to the "LOCK" (OFF) position.

Q: Is the sensor operating properly?

YES : It can be assumed that this malfunction is intermittent. Refer to GROUP 00, How to Use Troubleshooting/Inspection Service Points –How to Cope with Intermittent Malfunctions [P.00-15](#).

NO : Replace the ECM. When the ECM is replaced, register the ID code. Refer to GROUP 42B, ID Code Registration Necessity Judgment Table <Vehicles with KOS> [P.42B-11](#) or GROUP 42C, ID Codes Registration Judgment Table <Vehicles with WCM> [P.42C-9](#). Then go to Step 7.

STEP 6. Check harness connector B-18 at the manifold absolute pressure sensor and harness connector B-09 at ECM for damage.

Q: Is the harness connector in good condition?

YES : Replace the manifold absolute pressure sensor. Then go to Step 7.

NO : Repair or replace it. Refer to GROUP 00E, Harness Connector Inspection [P.00E-2](#). Then go to Step 7.

STEP 7. Test the OBD-II drive cycle.

- (1) Carry out a test drive with the drive cycle pattern. Refer to Diagnostic Function –OBD-II Drive Cycle –Pattern 23 P.13A-9.
- (2) Check the diagnostic trouble code (DTC).

Q: Is DTC P0108 set?

- YES :** Retry the troubleshooting.
NO : The inspection is complete.

DTC P0111: Intake Air Temperature Circuit Range/Performance Problem (sensor 1)

INTAKE AIR TEMPERATURE SENSOR 1 CIRCUIT

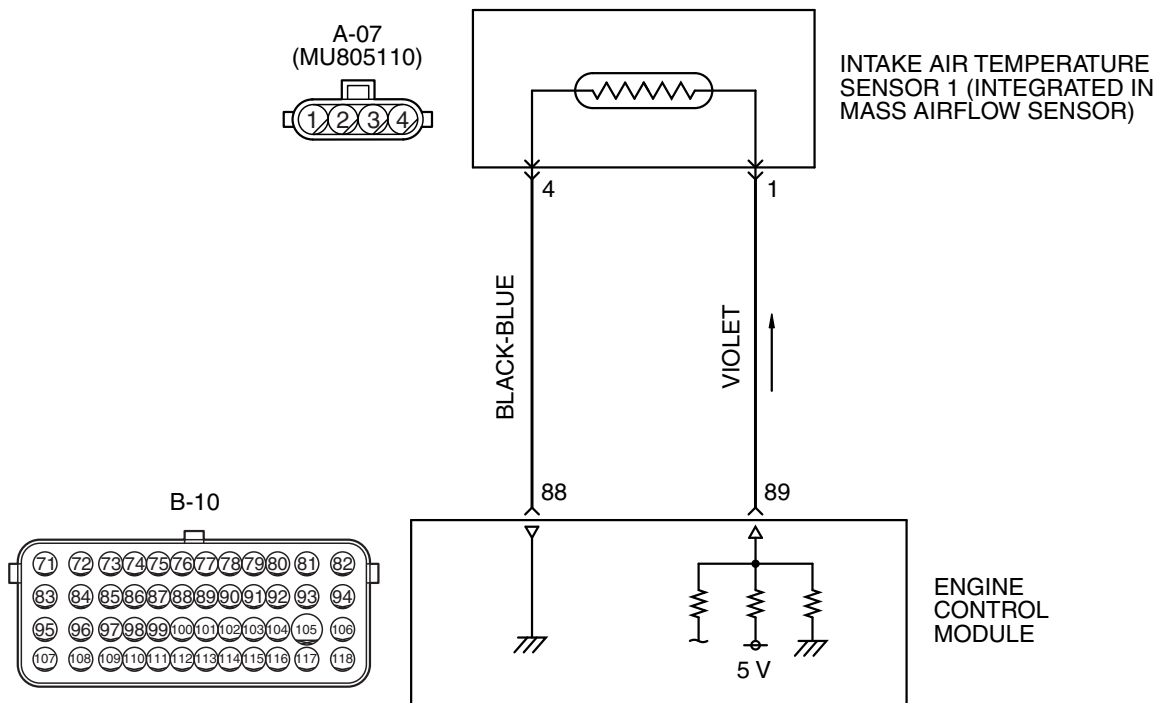

AK704241AB

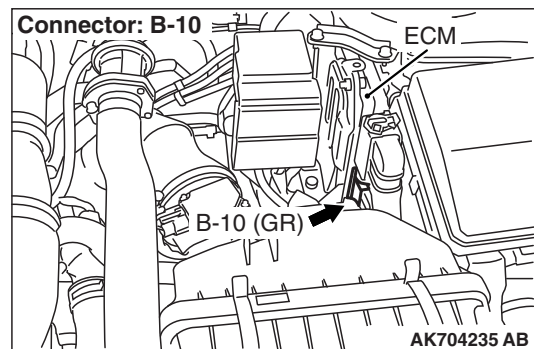
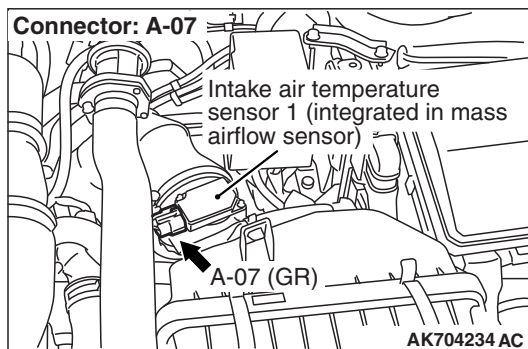

CIRCUIT OPERATION

- Approximately 5 volts are applied to the intake air temperature sensor 1 output terminal (terminal No. 1) from the ECM (terminal No. 89) via the resistor in the ECM. The ground terminal (terminal No. 4) is grounded with ECM (terminal No. 88).
- The intake air temperature sensor 1 is a negative temperature coefficient type of resistor. When the intake air temperature rises, the resistance decreases.
- The intake air temperature sensor 1 output voltage increases when the resistance increases and decreases when the resistance decreases.

TECHNICAL DESCRIPTION

- The intake air temperature sensor 1 converts the intake air temperature to a voltage.
- The ECM checks whether this voltage is within a specified range.

DESCRIPTIONS OF MONITOR METHODS

Intake air temperature sensor 1 output voltage does not change when specified go/stop operations are repeated.

MONITOR EXECUTION

Continuous

**MONITOR EXECUTION CONDITIONS
(Other monitor and Sensor)**

Other Monitor (There is no temporary DTC stored in memory for the item monitored below)

- Not applicable

Sensor (The sensor below is determined to be normal)

- Engine coolant temperature sensor

DTC SET CONDITIONS

Logic Flow Chart

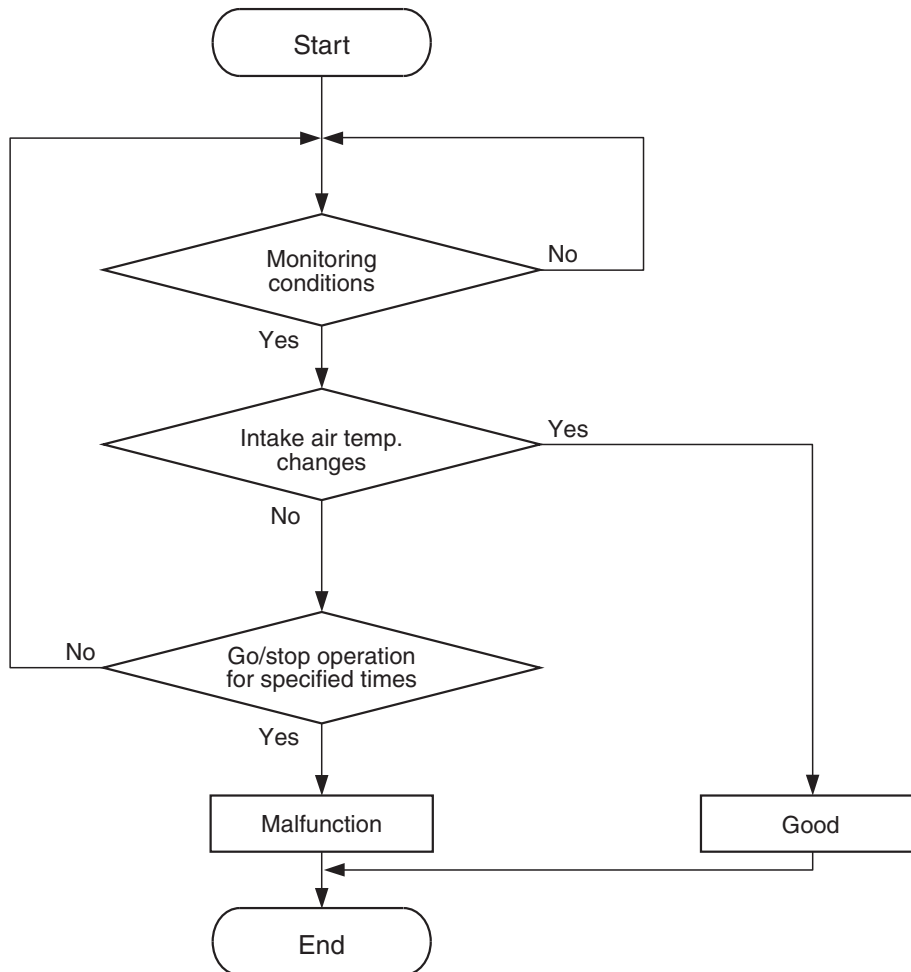

AK604314

Check Conditions

- Engine coolant temperature is higher than 76° C (169° F).
- Repeat 2 or more times: drive^{*1}, stop^{*2}.
Drive^{*1}: vehicle speed higher than 50 km/h (31 mph) lasting a total of 60 seconds or more.
Stop^{*2}: vehicle speed lower than 1.5 km/h (1.0 mph) lasting 30 seconds or more.

Judgement Criterion

- Changes in the intake air temperature is lower than 1° C (1.8° F).

FAIL-SAFE AND BACKUP FUNCTION

- Control as if the intake air temperature is 25 ° C.

OBD-II DRIVE CYCLE PATTERN

Refer to Diagnostic Function –OBD-II Drive Cycle – Pattern 7 P.13A-9.

TROUBLESHOOTING HINTS (The most likely causes for this code to be set are:)

- Intake air temperature sensor 1 failed.
- Harness damage or connector damage.
- ECM failed.

DIAGNOSIS**Required Special Tools:**

- MB991958: Scan Tool (M.U.T.-III Sub Assembly)
 - MB991824: V.C.I.
 - MB991827: USB Cable
 - MB991910: Main Harness A

STEP 1. Using scan tool MB991958, check data list item 5: Intake Air Temperature Sensor 1.**⚠ CAUTION**

To prevent damage to scan tool MB991958, always turn the ignition switch to the "LOCK" (OFF) position before connecting or disconnecting scan tool MB991958.

- (1) Connect scan tool MB991958 to the data link connector.
- (2) Remove the mass airflow sensor from the air intake hose.
- (3) Turn the ignition switch to the "ON" position.
- (4) Set scan tool MB991958 to the data reading mode for item 5, Intake Air Temperature Sensor 1.

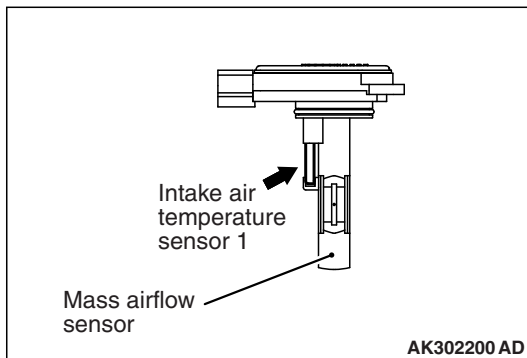
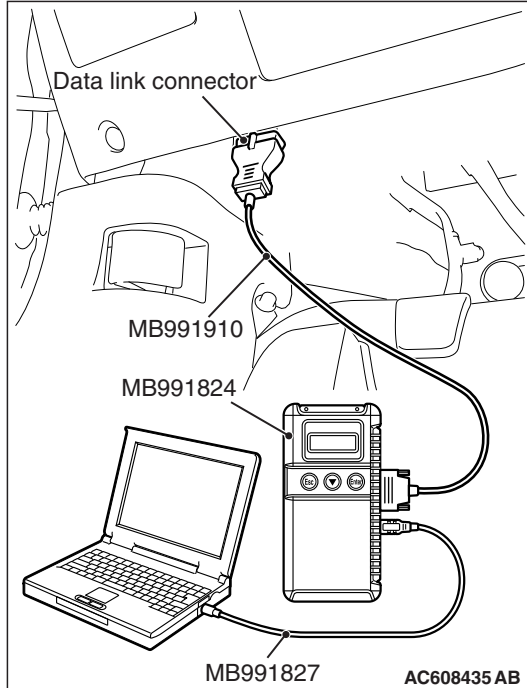

- (5) Heating the sensor using a hair drier.
 - The indicated temperature increases.

NOTE: Do not allow it to increase over 80°C (176°F).

- (6) Turn the ignition switch to the "LOCK" (OFF) position.
- (7) Attach the mass airflow sensor.

Q: Is the sensor operating properly?

YES : It can be assumed that this malfunction is intermittent. Refer to GROUP 00, How to Use Troubleshooting/Inspection Service Points –How to Cope with Intermittent Malfunctions [P.00-15](#).

NO : Go to Step 2.

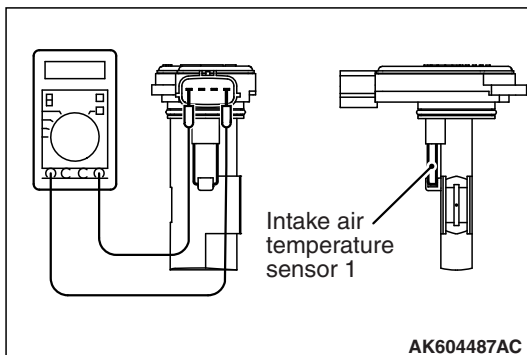
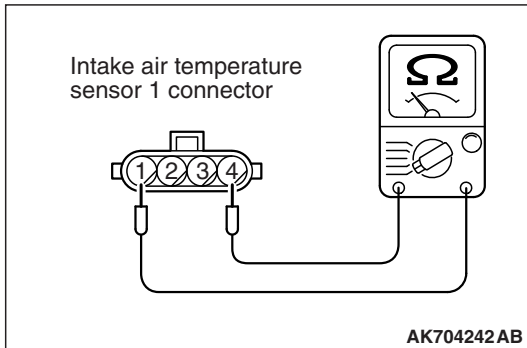

STEP 2. Check the intake air temperature sensor 1.

- (1) Disconnect the intake air temperature sensor 1 connector A-07.
- (2) Measure the resistance between intake air temperature sensor 1 side connector terminal No. 1 and No. 4.

- (3) Measure resistance while heating the sensor using a hair drier.

Standard value:

- 13 –17 k Ω [at –20° C (–4° F)]
- 5.4 –6.6 k Ω [at 0° C (32° F)]
- 2.3 –3.0 k Ω [at 20° C (68° F)]
- 1.0 –1.5 k Ω [at 40° C (104° F)]
- 0.56 –0.76 k Ω [at 60° C (140° F)]
- 0.31 –0.43 k Ω [at 80° C (176° F)]

Q: Is the measured resistance at the standard value?

YES : Go to Step 3.

NO : Replace the mass airflow sensor. Then go to Step 9.

STEP 3. Check harness connector A-07 at the intake air temperature sensor 1 for damage.

Q: Is the harness connector in good condition?

YES : Go to Step 4.

NO : Repair or replace it. Refer to GROUP 00E, Harness Connector Inspection [P.00E-2](#). Then go to Step 9.

STEP 4. Check the continuity at intake air temperature sensor 1 harness side connector A-07.

- (1) Disconnect the connector A-07 and measure at the harness side.
- (2) Check for the continuity between terminal No. 4 and ground.
 - Continuity (2 ohms or less)

Q: Does continuity exist?

YES : Go to Step 7.

NO : Go to Step 5.

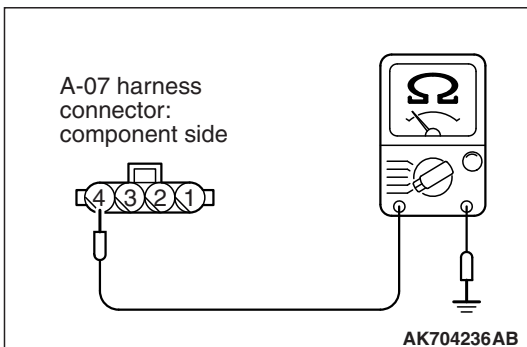

STEP 5. Check harness connector B-10 at ECM for damage.

Q: Is the harness connector in good condition?

YES : Go to Step 6.

NO : Repair or replace it. Refer to GROUP 00E, Harness Connector Inspection [P.00E-2](#). Then go to Step 9.

STEP 6. Check for harness damage between intake air temperature sensor 1 connector A-07 (terminal No. 4) and ECM connector B-10 (terminal No. 88).

Q: Is the harness wire in good condition?

YES : Replace the ECM. When the ECM is replaced, register the ID code. Refer to GROUP 42B, ID Code Registration Necessity Judgment Table <Vehicles with KOS> [P.42B-11](#) or GROUP 42C, ID Codes Registration Judgment Table <Vehicles with WCM> [P.42C-9](#). Then go to Step 9.

NO : Repair it. Then go to Step 9.

STEP 7. Check harness connector B-10 at ECM for damage.

Q: Is the harness connector in good condition?

YES : Go to Step 8.

NO : Repair or replace it. Refer to GROUP 00E, Harness Connector Inspection [P.00E-2](#). Then go to Step 9.

STEP 8. Check for harness damage between intake air temperature sensor 1 connector A-07 (terminal No. 1) and ECM connector B-10 (terminal No. 89).

Q: Is the harness wire in good condition?

YES : Replace the ECM. When the ECM is replaced, register the ID code. Refer to GROUP 42B, ID Code Registration Necessity Judgment Table <Vehicles with KOS> [P.42B-11](#) or GROUP 42C, ID Codes Registration Judgment Table <Vehicles with WCM> [P.42C-9](#). Then go to Step 9.

NO : Repair it. Then go to Step 9.

STEP 9. Test the OBD-II drive cycle.

(1) Carry out a test drive with the drive cycle pattern. Refer to Diagnostic Function –OBD-II Drive Cycle –Pattern 7 [P.13A-9](#).

(2) Check the diagnostic trouble code (DTC).

Q: Is DTC P0111 set?

YES : Retry the troubleshooting.

NO : The inspection is complete.

DTC P0112: Intake Air Temperature Circuit Low Input (sensor 1)

INTAKE AIR TEMPERATURE SENSOR 1 CIRCUIT

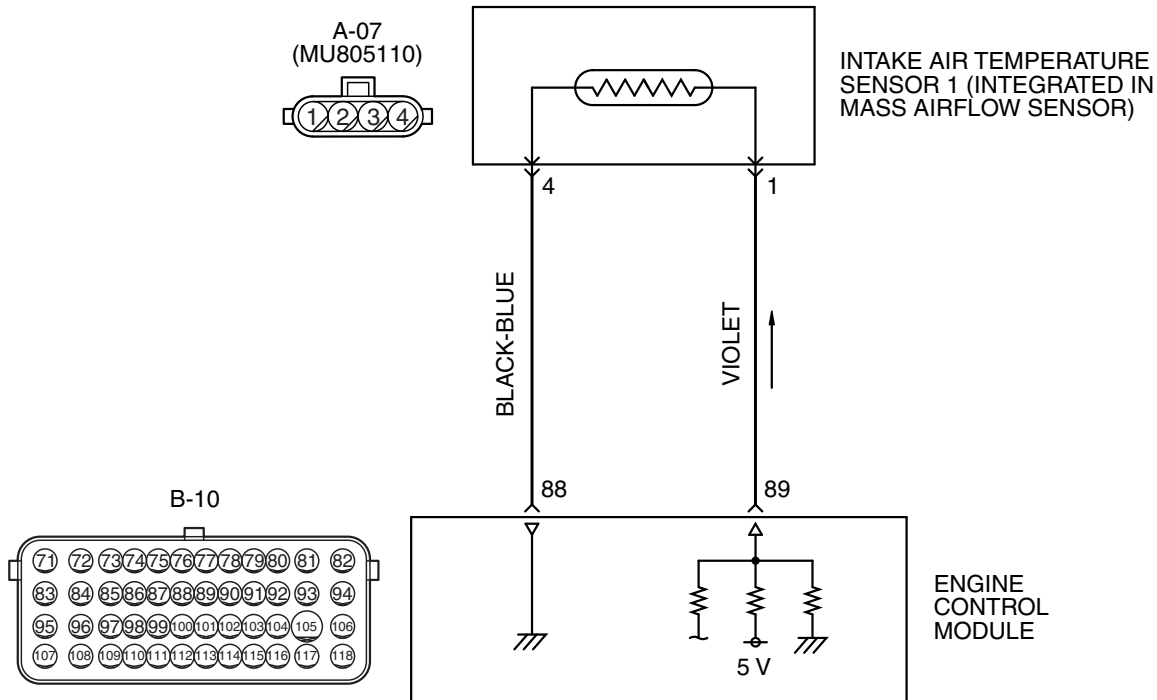

AK704241AB

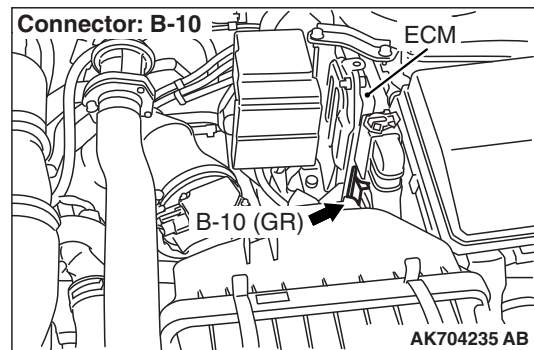
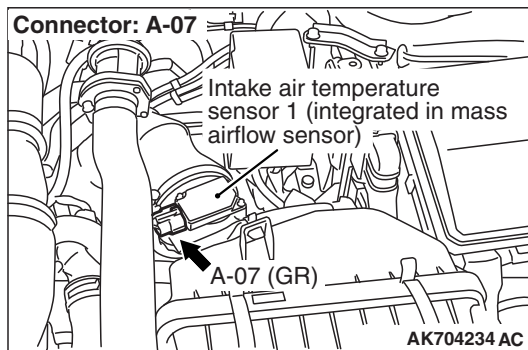

CIRCUIT OPERATION

- Approximately 5 volts are applied to the intake air temperature sensor 1 output terminal (terminal No. 1) from the ECM (terminal No. 89) via the resistor in the ECM. The ground terminal (terminal No. 4) is grounded with ECM (terminal No. 88).
- The intake air temperature sensor 1 is a negative temperature coefficient type of resistor. When the intake air temperature rises, the resistance decreases.

- The intake air temperature sensor 1 output voltage increases when the resistance increases and decreases when the resistance decreases.

TECHNICAL DESCRIPTION

- The intake air temperature sensor 1 converts the intake air temperature to a voltage.
- The ECM checks whether this voltage is within a specified range.

DESCRIPTIONS OF MONITOR METHODS

Intake air temperature sensor 1 output voltage is out of specified range.

MONITOR EXECUTION

Continuous

**MONITOR EXECUTION CONDITIONS
(Other monitor and Sensor)**

Other Monitor (There is no temporary DTC stored in memory for the item monitored below)

- Not applicable

Sensor (The sensor below is determined to be normal)

- Not applicable

DTC SET CONDITIONS

Logic Flow Chart

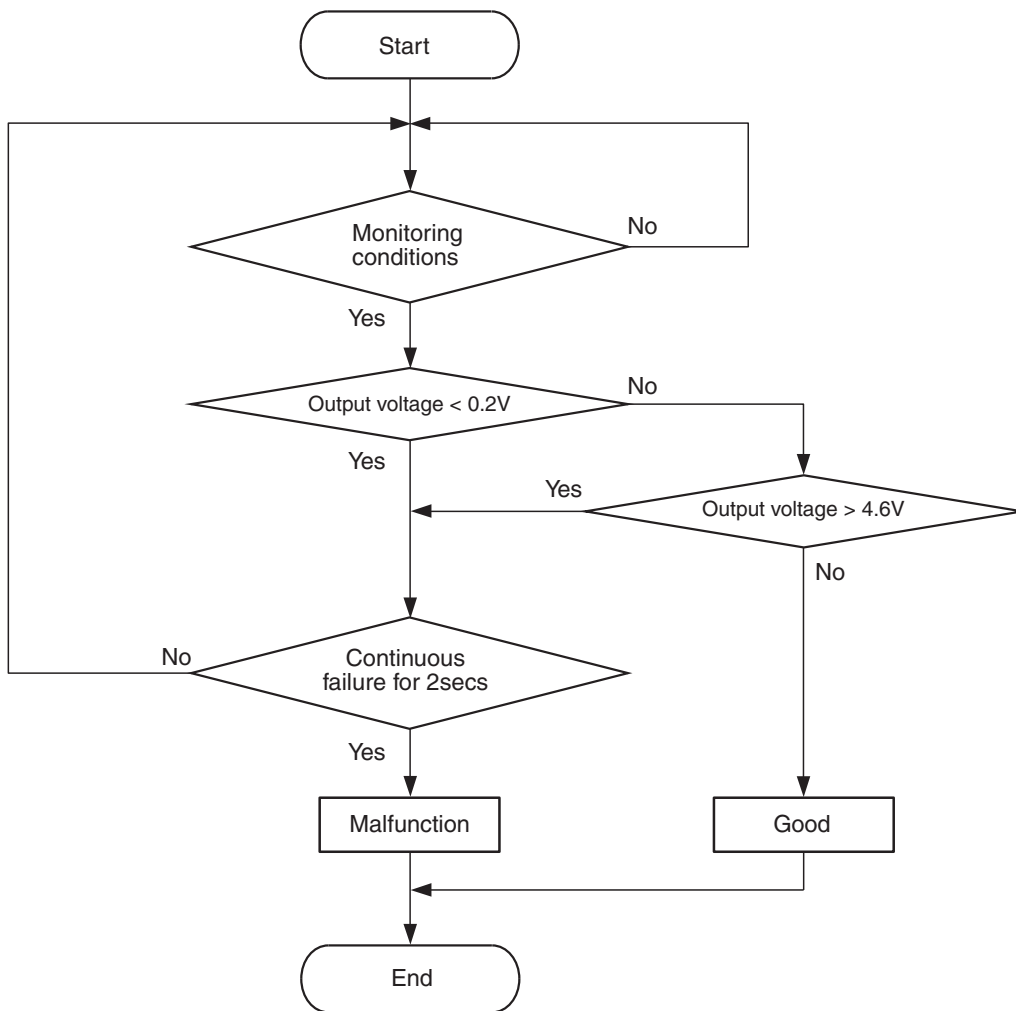

AK604315

Check Condition

- 2 seconds or more have passed since the engine starting sequence was completed.

Judgement Criterion

- Intake air temperature sensor 1 output voltage has continued to be 0.2 volt or lower [corresponding to an intake air temperature of 115° C (239° F) or higher] for 2 seconds.

FAIL-SAFE AND BACKUP FUNCTION

- Control as if the intake air temperature is 25 °C.

OBD-II DRIVE CYCLE PATTERN

Refer to Diagnostic Function –OBD-II Drive Cycle –
Pattern 23 [P.13A-9](#).

TROUBLESHOOTING HINTS (The most likely causes for this code to be set are:)

- Intake air temperature sensor 1 failed.
- Shorted intake air temperature sensor 1 circuit, or connector damage.
- ECM failed.

DIAGNOSIS

Required Special Tools:

- MB991958: Scan Tool (M.U.T.-III Sub Assembly)
 - MB991824: V.C.I.
 - MB991827: USB Cable
 - MB991910: Main Harness A

STEP 1. Using scan tool MB991958, check data list item 5: Intake Air Temperature Sensor 1.

CAUTION

To prevent damage to scan tool MB991958, always turn the ignition switch to the "LOCK" (OFF) position before connecting or disconnecting scan tool MB991958.

- (1) Connect scan tool MB991958 to the data link connector.
- (2) Turn the ignition switch to the "ON" position.
- (3) Set scan tool MB991958 to the data reading mode for item 5, Intake Air Temperature Sensor 1.
 - The intake air temperature and temperature shown with the scan tool should approximately match.
- (4) Turn the ignition switch to the "LOCK" (OFF) position.

Q: Is the sensor operating properly?

YES : It can be assumed that this malfunction is intermittent. Refer to GROUP 00, How to Use Troubleshooting/Inspection Service Points –How to Cope with Intermittent Malfunctions [P.00-15](#).

NO : Go to Step 2.

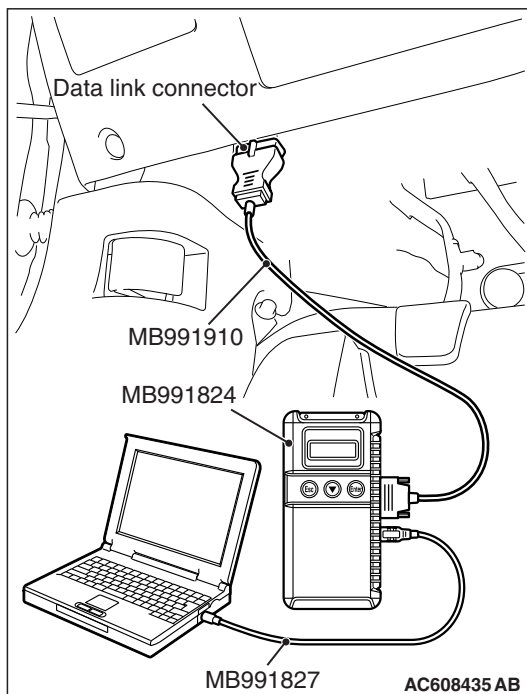

STEP 2. Check harness connector A-07 at the intake air temperature sensor 1 for damage.

Q: Is the harness connector in good condition?

YES : Go to Step 3.

NO : Repair or replace it. Refer to GROUP 00E, Harness Connector Inspection [P.00E-2](#). Then go to Step 6.

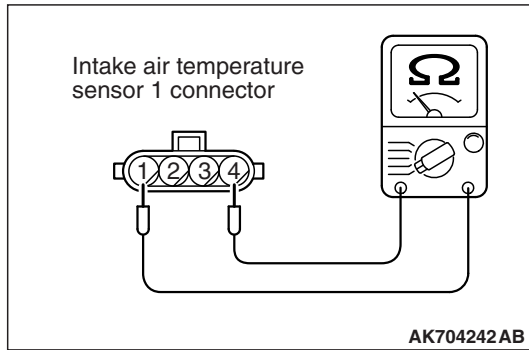
**STEP 3. Check the intake air temperature sensor 1.**

- (1) Disconnect the intake air temperature sensor 1 connector A-07.
- (2) Measure the resistance between intake air temperature sensor 1 side connector terminal No. 1 and No. 4.
 - There should be continuity. (0.31 –17 kΩ)

Q: Is the measured resistance between 0.31 and 17 kΩ?

YES : Go to Step 4.

NO : Replace the mass airflow sensor. Then go to Step 6.

STEP 4. Check for short circuit to ground between intake air temperature sensor 1 connector A-07 (terminal No. 1) and ECM connector B-10 (terminal No. 89).

Q: Is the harness wire in good condition?

YES : Go to Step 5.

NO : Repair it. Then go to Step 6.

STEP 5. Check harness connector B-10 at ECM for damage.

Q: Is the harness connector in good condition?

YES : Replace the ECM. When the ECM is replaced, register the ID code. Refer to GROUP 42B, ID Code Registration Necessity Judgment Table <Vehicles with KOS> [P.42B-11](#) or GROUP 42C, ID Codes Registration Judgment Table <Vehicles with WCM> [P.42C-9](#). Then go to Step 6.

NO : Repair or replace it. Refer to GROUP 00E, Harness Connector Inspection [P.00E-2](#). Then go to Step 6.

STEP 6. Test the OBD-II drive cycle.

- (1) Carry out a test drive with the drive cycle pattern. Refer to Diagnostic Function –OBD-II Drive Cycle –Pattern 23 [P.13A-9](#).
- (2) Check the diagnostic trouble code (DTC).

Q: Is DTC P0112 set?

YES : Retry the troubleshooting.

NO : The inspection is complete.

DTC P0113: Intake Air Temperature Circuit High Input (sensor 1)

INTAKE AIR TEMPERATURE SENSOR 1 CIRCUIT

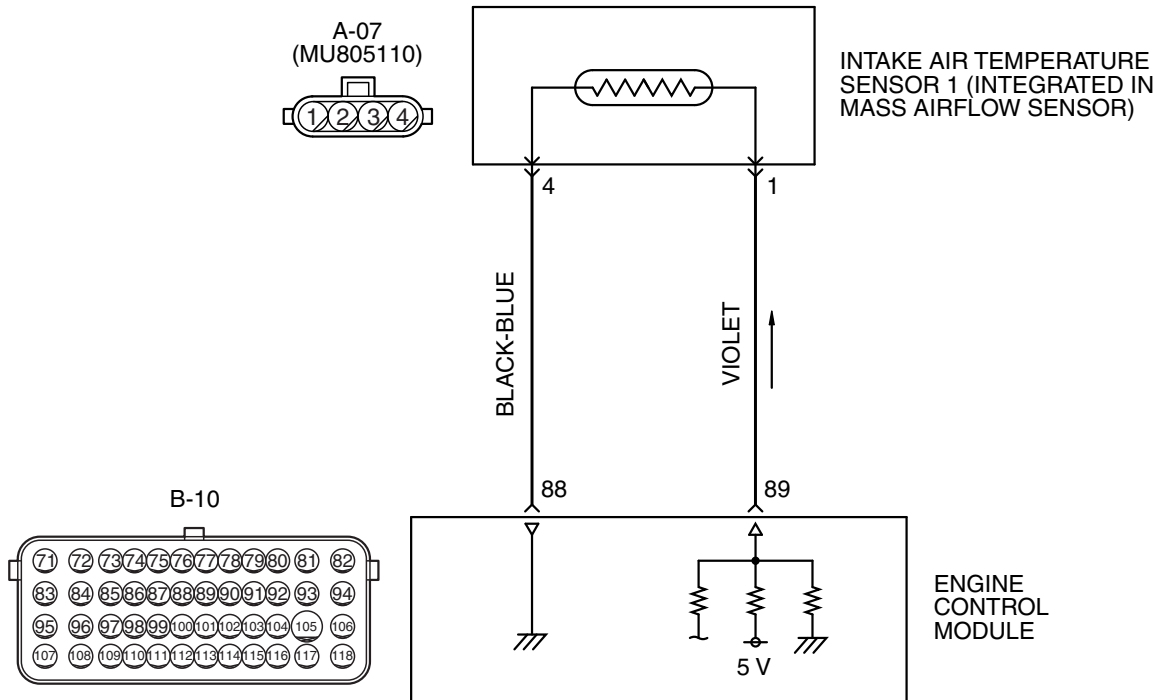

AK704241AB

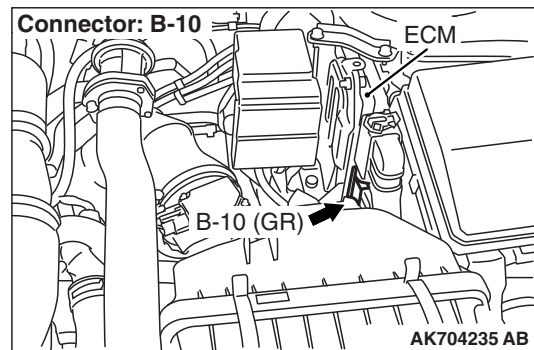
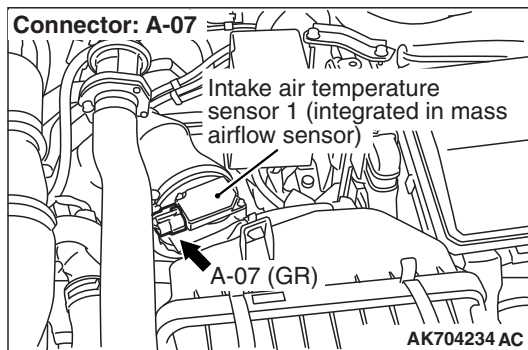

CIRCUIT OPERATION

- Approximately 5 volts are applied to the intake air temperature sensor 1 output terminal (terminal No. 1) from the ECM (terminal No. 89) via the resistor in the ECM. The ground terminal (terminal No. 4) is grounded with ECM (terminal No. 88).
- The intake air temperature sensor 1 is a negative temperature coefficient type of resistor. When the intake air temperature rises, the resistance decreases.

- The intake air temperature sensor 1 output voltage increases when the resistance increases and decreases when the resistance decreases.

TECHNICAL DESCRIPTION

- The intake air temperature sensor 1 converts the intake air temperature to a voltage.
- The ECM checks whether this voltage is within a specified range.

DESCRIPTIONS OF MONITOR METHODS

Intake air temperature sensor 1 output voltage is out of specified range.

MONITOR EXECUTION

Continuous

**MONITOR EXECUTION CONDITIONS
(Other monitor and Sensor)**

Other Monitor (There is no temporary DTC stored in memory for the item monitored below)

- Not applicable

Sensor (The sensor below is determined to be normal)

- Not applicable

DTC SET CONDITIONS

Logic Flow Chart

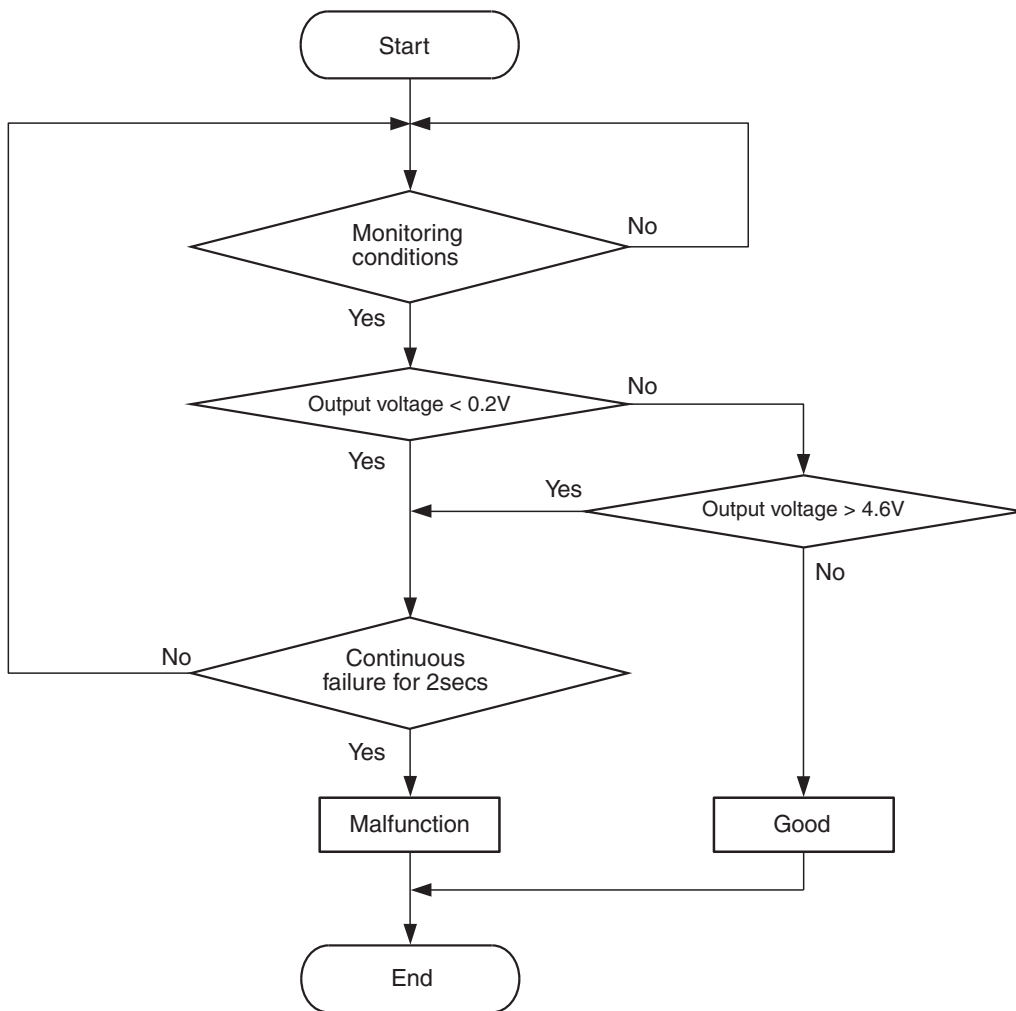

AK604315

Check Condition

- 2 seconds or more have passed since the engine starting sequence was completed.

Judgement Criterion

- Intake air temperature sensor 1 output voltage has continued to be 4.6 volts or higher [corresponding to an intake air temperature of -40° C (-40° F) or lower] for 2 seconds.

FAIL-SAFE AND BACKUP FUNCTION

- Control as if the intake air temperature is 25 °C.

OBD-II DRIVE CYCLE PATTERN

Refer to Diagnostic Function –OBD-II Drive Cycle –
Pattern 23 [P.13A-9](#).

TROUBLESHOOTING HINTS (The most likely causes for this code to be set are:)

- Intake air temperature sensor 1 failed.
- Open intake air temperature sensor 1 circuit, or connector damage.
- ECM failed.

DIAGNOSIS

Required Special Tools:

- MB991958: Scan Tool (M.U.T.-III Sub Assembly)
 - MB991824: V.C.I.
 - MB991827: USB Cable
 - MB991910: Main Harness A
- MB992110: Power Plant ECU Check Harness

STEP 1. Using scan tool MB991958, check data list item 5: Intake Air Temperature Sensor 1.

CAUTION

To prevent damage to scan tool MB991958, always turn the ignition switch to the "LOCK" (OFF) position before connecting or disconnecting scan tool MB991958.

- (1) Connect scan tool MB991958 to the data link connector.
- (2) Turn the ignition switch to the "ON" position.
- (3) Set scan tool MB991958 to the data reading mode for item 5, Intake Air Temperature Sensor 1.
 - The intake air temperature and temperature shown with the scan tool should approximately match.
- (4) Turn the ignition switch to the "LOCK" (OFF) position.

Q: Is the sensor operating properly?

YES : It can be assumed that this malfunction is intermittent. Refer to GROUP 00, How to Use Troubleshooting/Inspection Service Points –How to Cope with Intermittent Malfunctions [P.00-15](#).

NO : Go to Step 2.

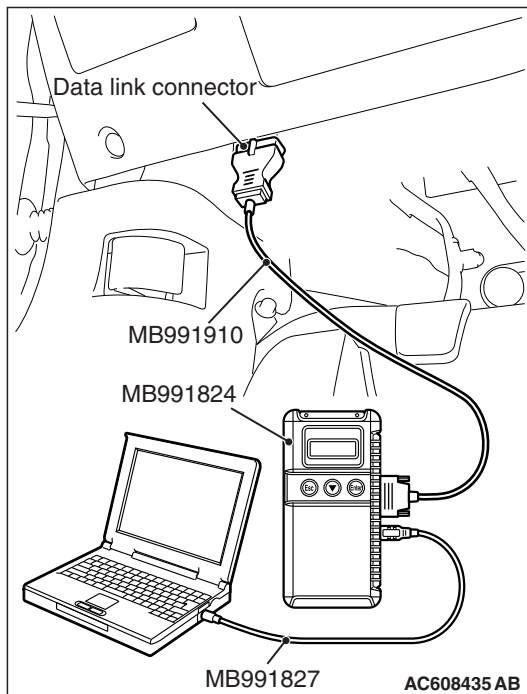

STEP 2. Check harness connector A-07 at the intake air temperature sensor 1 for damage.

Q: Is the harness connector in good condition?

YES : Go to Step 3.

NO : Repair or replace it. Refer to GROUP 00E, Harness Connector Inspection [P.00E-2](#). Then go to Step 10.

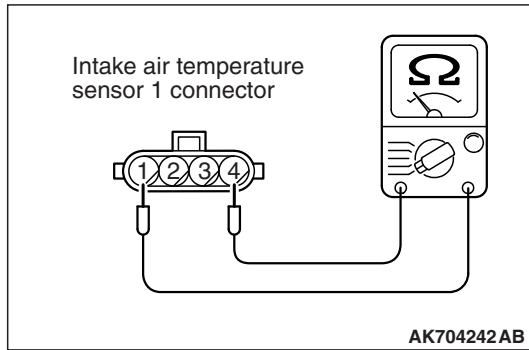
**STEP 3. Check the intake air temperature sensor 1.**

- (1) Disconnect the intake air temperature sensor 1 connector A-07.
- (2) Measure the resistance between intake air temperature sensor 1 side connector terminal No. 1 and No. 4.
 - There should be continuity. (0.31 –17 k Ω)

Q: Is the measured resistance between 0.31 and 17 k Ω ?

YES : Go to Step 4.

NO : Replace the mass airflow sensor. Then go to Step 10.

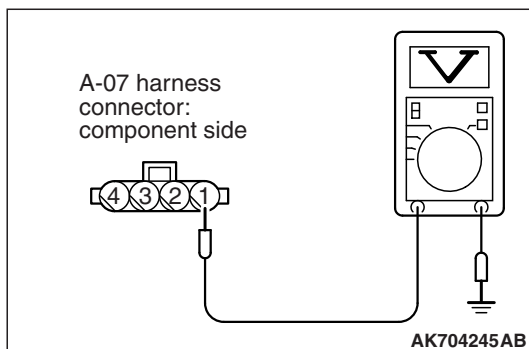
**STEP 4. Measure the sensor supply voltage at intake air temperature sensor 1 harness side connector A-07.**

- (1) Disconnect the connector A-07 and measure at the harness side.
- (2) Turn the ignition switch to the "ON" position.
- (3) Measure the voltage between terminal No. 1 and ground.
 - Voltage should be between 4.5 and 4.9 volts.
- (4) Turn the ignition switch to the "LOCK" (OFF) position.

Q: Is the measured voltage between 4.5 and 4.9 volts?

YES : Go to Step 7.

NO : Go to Step 5.

STEP 5. Check harness connector B-10 at ECM for damage.

Q: Is the harness connector in good condition?

YES : Go to Step 6.

NO : Repair or replace it. Refer to GROUP 00E, Harness Connector Inspection [P.00E-2](#). Then go to Step 10.

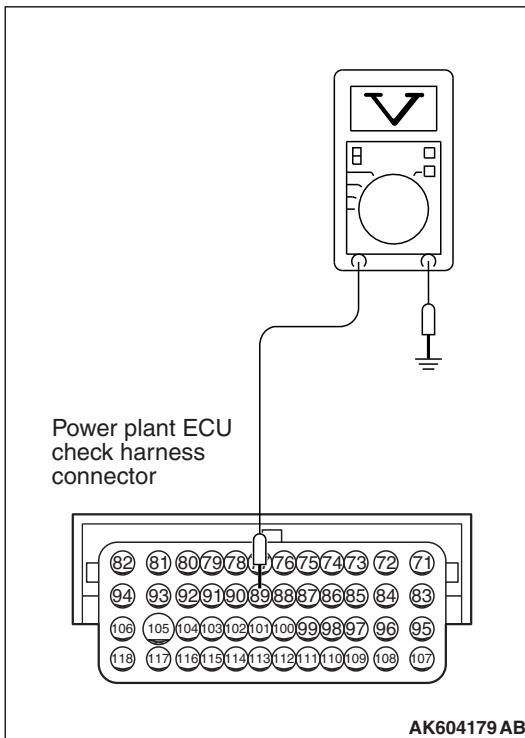
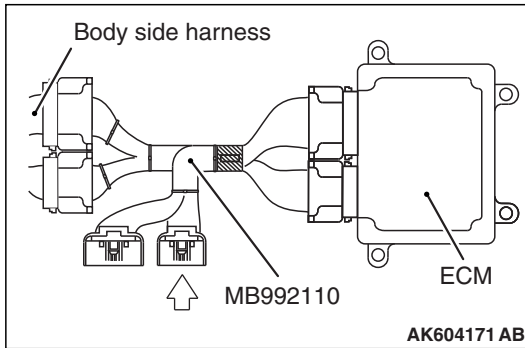

STEP 6. Measure the sensor supply voltage at ECM connector B-10 by using power plant ECU check harness special tool MB992110.

- (1) Disconnect all ECM connectors. Connect the power plant ECU check harness special tool MB992110 between the separated connectors.
- (2) Disconnect the intake air temperature sensor 1 connector A-07.
- (3) Turn the ignition switch to the "ON" position.

- (4) Measure the voltage between terminal No. 89 and ground.
 - Voltage should be between 4.5 and 4.9 volts.
- (5) Turn the ignition switch to the "LOCK" (OFF) position.

Q: Is the measured voltage between 4.5 and 4.9 volts?

YES : Repair harness wire between intake air temperature sensor 1 connector A-07 (terminal No. 1) and ECM connector B-10 (terminal No. 89) because of open circuit. Then go to Step 10.

NO : Replace the ECM. When the ECM is replaced, register the ID code. Refer to GROUP 42B, ID Code Registration Necessity Judgment Table <Vehicles with KOS> [P.42B-11](#) or GROUP 42C, ID Codes Registration Judgment Table <Vehicles with WCM> [P.42C-9](#). Then go to Step 10.

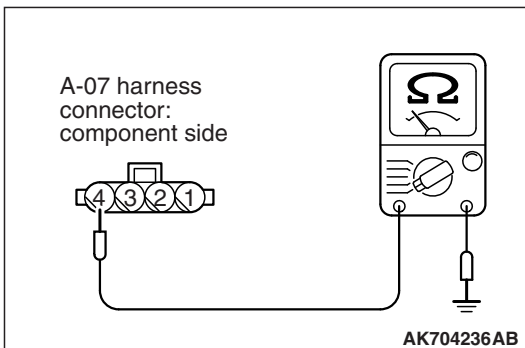

STEP 7. Check the continuity at intake air temperature sensor 1 harness side connector A-07.

- (1) Disconnect the connector A-07 and measure at the harness side.
- (2) Check for the continuity between terminal No. 4 and ground.
 - Continuity (2 ohms or less)

Q: Does continuity exist?

YES : Replace the ECM. When the ECM is replaced, register the ID code. Refer to GROUP 42B, ID Code Registration Necessity Judgment Table <Vehicles with KOS> [P.42B-11](#) or GROUP 42C, ID Codes Registration Judgment Table <Vehicles with WCM> [P.42C-9](#). Then go to Step 10.

NO : Go to Step 8.

STEP 8. Check harness connector B-10 at ECM for damage.

Q: Is the harness connector in good condition?

YES : Go to Step 9.

NO : Repair or replace it. Refer to GROUP 00E, Harness Connector Inspection [P.00E-2](#). Then go to Step 10.

STEP 9. Check for open circuit between intake air temperature sensor 1 connector A-07 (terminal No. 4) and ECM connector B-10 (terminal No. 88).

Q: Is the harness wire in good condition?

YES : Replace the ECM. When the ECM is replaced, register the ID code. Refer to GROUP 42B, ID Code Registration Necessity Judgment Table <Vehicles with KOS> [P.42B-11](#) or GROUP 42C, ID Codes Registration Judgment Table <Vehicles with WCM> [P.42C-9](#). Then go to Step 10.

NO : Repair it. Then go to Step 10.

STEP 10. Test the OBD-II drive cycle.

(1) Carry out a test drive with the drive cycle pattern. Refer to Diagnostic Function –OBD-II Drive Cycle –Pattern 23 [P.13A-9](#).

(2) Check the diagnostic trouble code (DTC).

Q: Is DTC P0113 set?

YES : Retry the troubleshooting.

NO : The inspection is complete.

DTC P0116: Engine Coolant Temperature Circuit Range/Performance Problem

ENGINE COOLANT TEMPERATURE SENSOR CIRCUIT

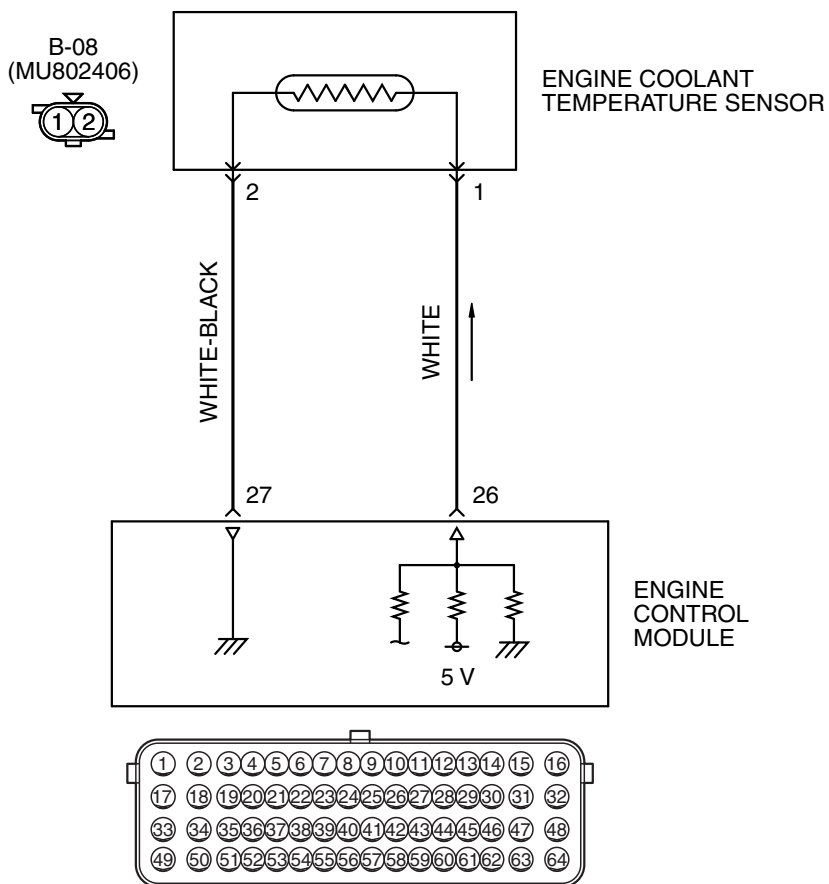

AK603948 AD

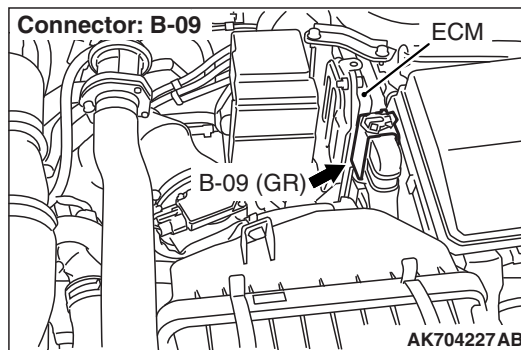
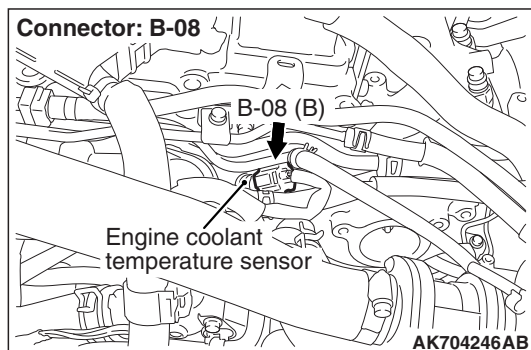

CIRCUIT OPERATION

- 5-volt voltage is applied to the engine coolant temperature sensor output terminal (terminal No. 1) from the ECM (terminal No. 26) via the resistor in the ECM. The ground terminal (terminal No. 2) is grounded with ECM (terminal No. 27).
- The engine coolant temperature sensor is a negative temperature coefficient type of resistor. It has the characteristic that when the engine coolant temperature rises the resistance decreases.
- The engine coolant temperature sensor output voltage increases when the resistance increases and decreases when the resistance decreases.

TECHNICAL DESCRIPTION

- The engine coolant temperature sensor converts the engine coolant temperature to a voltage and outputs it.
- The ECM checks whether this voltage is within a specified range.

DESCRIPTIONS OF MONITOR METHODS

Engine coolant temperature sensor output voltage does not change for specified period when engine coolant temperature sensor output voltage at engine start is over 7° C (45° F).

MONITOR EXECUTION

Once per driving cycle

**MONITOR EXECUTION CONDITIONS
(Other monitor and Sensor)**

Other Monitor (There is no temporary DTC stored in memory for the item monitored below)

- Not applicable

Sensor (The sensor below is determined to be normal)

- Mass airflow sensor
- Intake air temperature sensor

DTC SET CONDITIONS

Logic Flow Chart

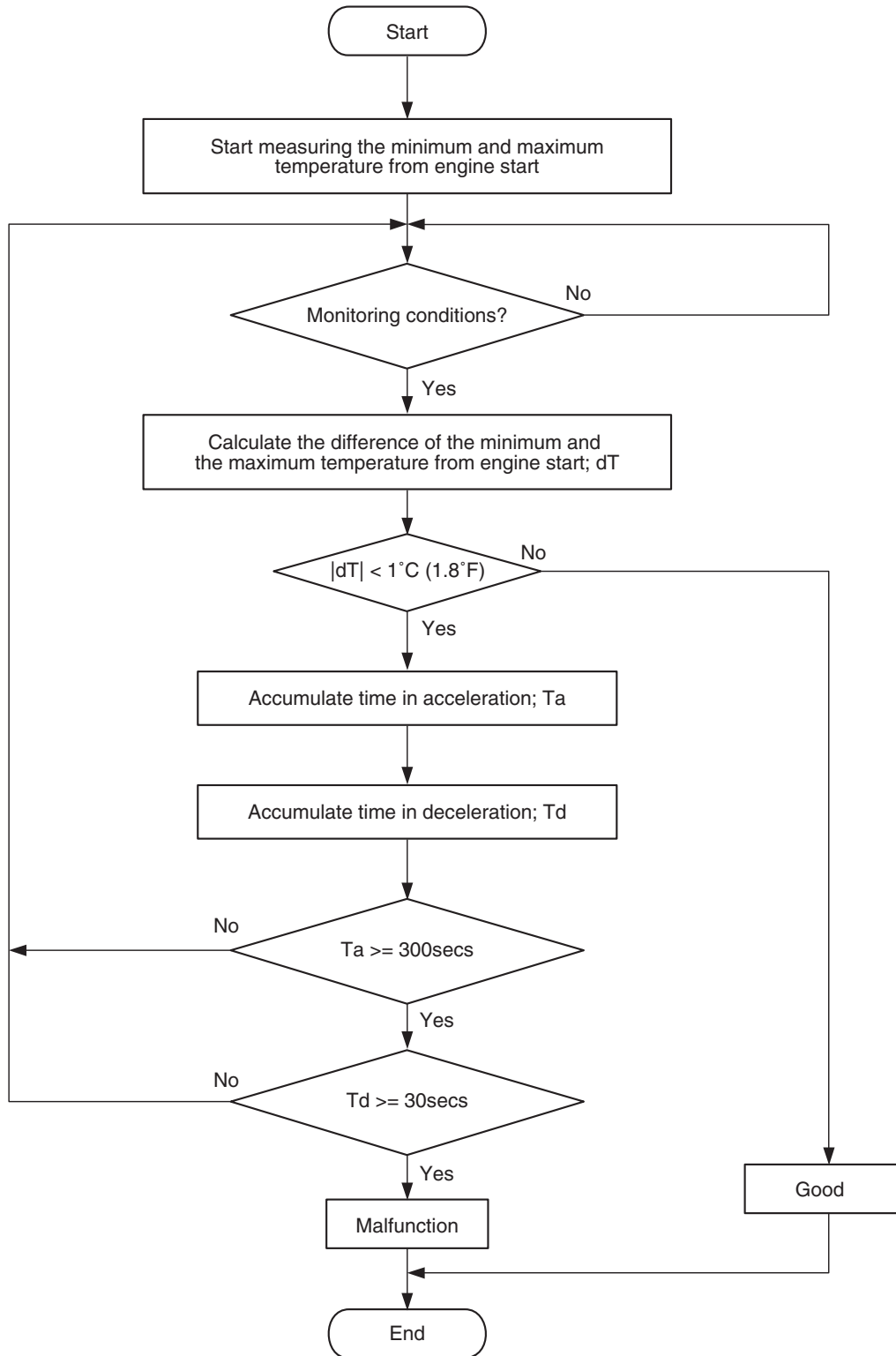

Check Conditions

- Engine coolant temperature was more than 7° C (45° F) when the engine started.
- The accumulation is more than 300 seconds during the acceleration having the mass airflow rate of 12 g/sec or more.
- The accumulation is more than 30 seconds during the deceleration having the mass airflow rate of 9 g/sec or less.

Judgement Criteria

- Engine coolant temperature fluctuates within 1° C (1.8° F) after 330 seconds have passed since the engine was started.
- However, time is not counted if any of the following conditions are met.
 1. Intake air temperature is more than 60° C (140° F).
 2. During fuel shut-off operation.

FAIL-SAFE AND BACKUP FUNCTION

- Control as if the engine coolant temperature is 80° C.

OBD-II DRIVE CYCLE PATTERN

Refer to Diagnostic Function –OBD-II Drive Cycle – Pattern 8 [P.13A-9](#).

TROUBLESHOOTING HINTS (The most likely causes for this code to be set are:)

- Engine coolant temperature sensor failed.
- Harness damage or connector damage.
- ECM failed.

DIAGNOSIS**Required Special Tools:**

- MB991958: Scan Tool (M.U.T.-III Sub Assembly)
 - MB991824: V.C.I.
 - MB991827: USB Cable
 - MB991910: Main Harness A

STEP 1. Using scan tool MB991958, check data list item 6: Engine Coolant Temperature Sensor.**⚠ CAUTION**

To prevent damage to scan tool MB991958, always turn the ignition switch to the "LOCK" (OFF) position before connecting or disconnecting scan tool MB991958.

- (1) Connect scan tool MB991958 to the data link connector.
- (2) Turn the ignition switch to the "ON" position.
- (3) Set scan tool MB991958 to the data reading mode for item 6, Engine Coolant Temperature Sensor.
 - The engine coolant temperature and temperature shown with the scan tool should approximately match.
- (4) Turn the ignition switch to the "LOCK" (OFF) position.

Q: Is the sensor operating properly?

YES : It can be assumed that this malfunction is intermittent. Refer to GROUP 00, How to Use Troubleshooting/Inspection Service Points –How to Cope with Intermittent Malfunctions [P.00-15](#).

NO : Go to Step 2.

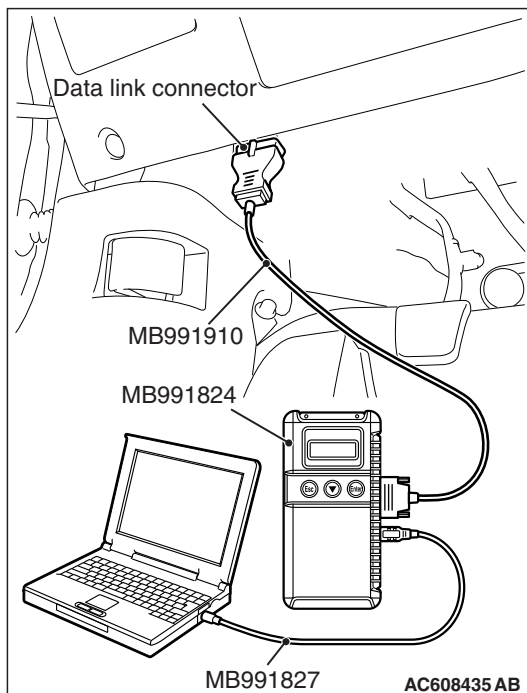

STEP 2. Check the engine coolant temperature sensor.

Refer to Engine Coolant Temperature Sensor Check
[P.13A-875](#).

Q: Is the engine coolant temperature sensor normal?

YES : Go to Step 3.

NO : Replace the engine coolant temperature sensor. Then go to Step 9.

STEP 3. Check harness connector B-08 at the engine coolant temperature sensor for damage.

Q: Is the harness connector in good condition?

YES : Go to Step 4.

NO : Repair or replace it. Refer to GROUP 00E, Harness Connector Inspection [P.00E-2](#). Then go to Step 9.

STEP 4. Check the continuity at engine coolant temperature sensor harness side connector B-08.

(1) Disconnect the connector B-08 and measure at the harness side.

(2) Check for the continuity between terminal No. 2 and ground.

- Continuity (2 ohms or less)

Q: Does continuity exist?

YES : Go to Step 7.

NO : Go to Step 5.

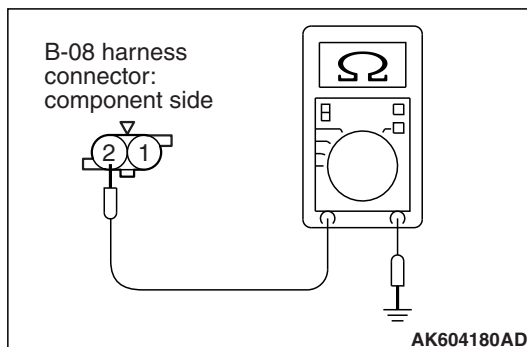

STEP 5. Check harness connector B-09 at ECM for damage.

Q: Is the harness connector in good condition?

YES : Go to Step 6.

NO : Repair or replace it. Refer to GROUP 00E, Harness Connector Inspection [P.00E-2](#). Then go to Step 9.

STEP 6. Check for harness damage between engine coolant temperature sensor connector B-08 (terminal No. 2) and ECM connector B-09 (terminal No. 27).

Q: Is the harness wire in good condition?

YES : Replace the ECM. When the ECM is replaced, register the ID code. Refer to GROUP 42B, ID Code Registration Necessity Judgment Table <Vehicles with KOS> [P.42B-11](#) or GROUP 42C, ID Codes Registration Judgment Table <Vehicles with WCM> [P.42C-9](#). Then go to Step 9.

NO : Repair it. Then go to Step 9.

STEP 7. Check harness connector B-09 at ECM for damage.

Q: Is the harness connector in good condition?

YES : Go to Step 8.

NO : Repair or replace it. Refer to GROUP 00E, Harness Connector Inspection [P.00E-2](#). Then go to Step 9.

STEP 8. Check for harness damage between engine coolant temperature sensor connector B-08 (terminal No. 1) and ECM connector B-09 (terminal No. 26).

Q: Is the harness wire in good condition?

YES : Replace the ECM. When the ECM is replaced, register the ID code. Refer to GROUP 42B, ID Code Registration Necessity Judgment Table <Vehicles with KOS> [P.42B-11](#) or GROUP 42C, ID Codes Registration Judgment Table <Vehicles with WCM> [P.42C-9](#). Then go to Step 9.

NO : Repair it. Then go to Step 9.

STEP 9. Test the OBD-II drive cycle.

(1) Carry out a test drive with the drive cycle pattern. Refer to Diagnostic Function –OBD-II Drive Cycle –Pattern 8 [P.13A-9](#).

(2) Check the diagnostic trouble code (DTC).

Q: Is DTC P0116 set?

YES : Retry the troubleshooting.

NO : The inspection is complete.

DTC P0117: Engine Coolant Temperature Circuit Low Input

ENGINE COOLANT TEMPERATURE SENSOR CIRCUIT

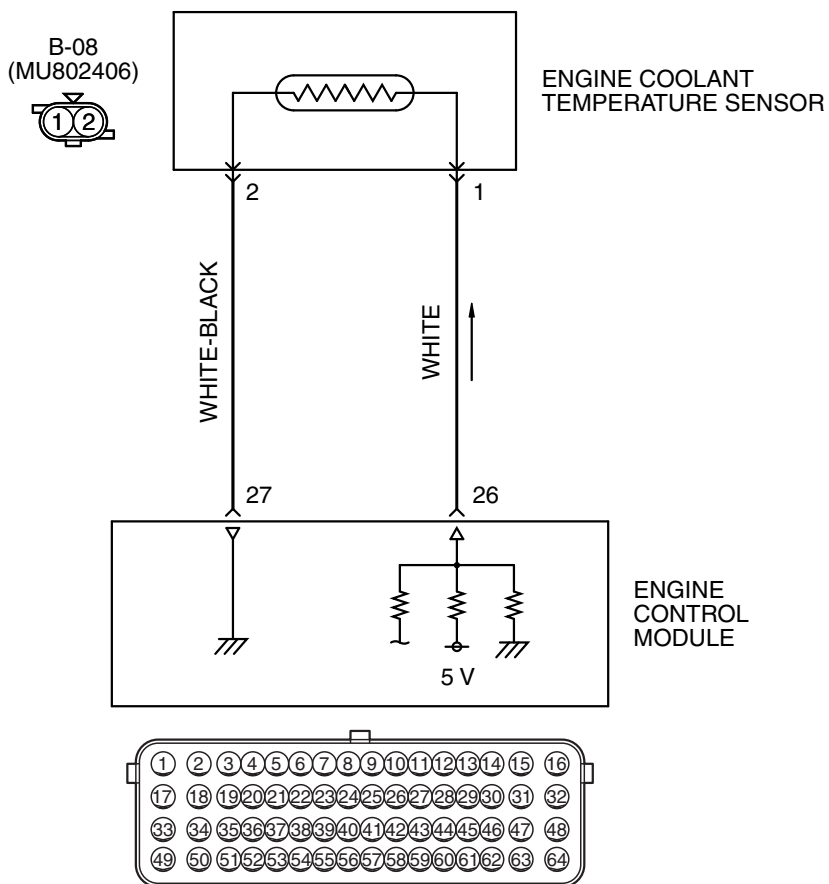

B-09

AK603948 AD

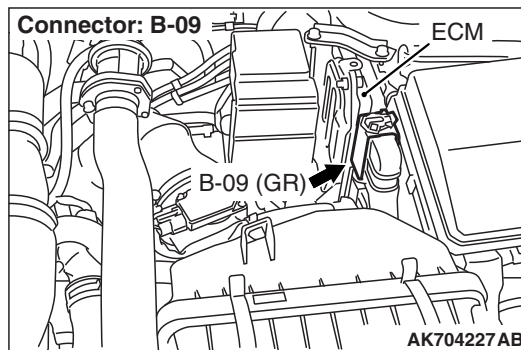
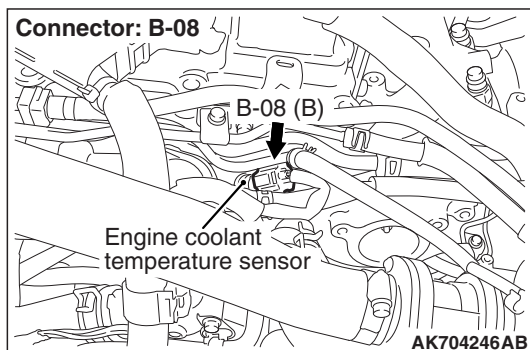

CIRCUIT OPERATION

- 5-volt voltage is applied to the engine coolant temperature sensor output terminal (terminal No. 1) from the ECM (terminal No. 26) via the resistor in the ECM. The ground terminal (terminal No. 2) is grounded with ECM (terminal No. 27).
- The engine coolant temperature sensor is a negative temperature coefficient type of resistor. It has the characteristic that when the engine coolant temperature rises the resistance decreases.
- The engine coolant temperature sensor output voltage increases when the resistance increases and decreases when the resistance decreases.

TECHNICAL DESCRIPTION

- The engine coolant temperature sensor converts the engine coolant temperature to a voltage and outputs it.
- The ECM checks whether this voltage is within a specified range.

DESCRIPTIONS OF MONITOR METHODS

Engine coolant temperature sensor output voltage is out of specified range.

MONITOR EXECUTION

Continuous

**MONITOR EXECUTION CONDITIONS
(Other monitor and Sensor)**

Other Monitor (There is no temporary DTC stored in memory for the item monitored below)

- Not applicable

Sensor (The sensor below is determined to be normal)

- Not applicable

DTC SET CONDITIONS

Logic Flow Chart

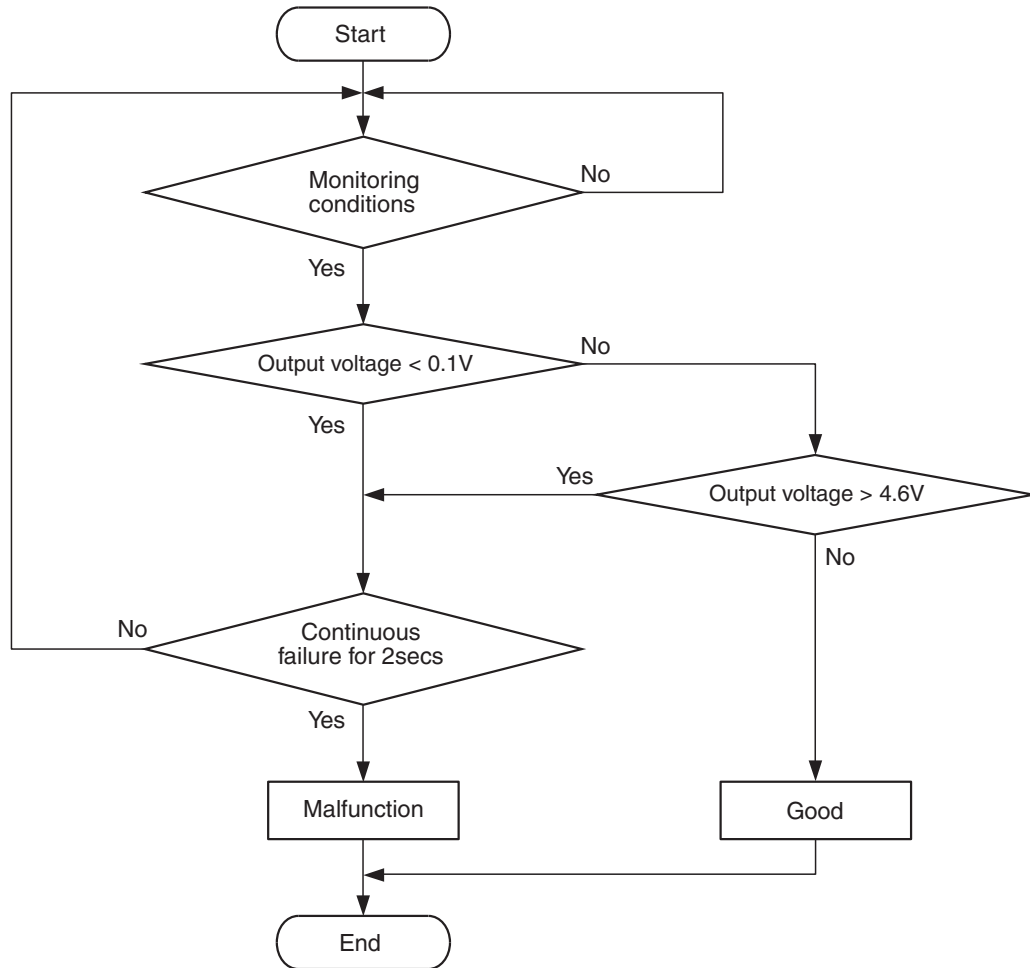

AK604317

Check Condition

- 2 seconds or more have passed since the engine starting sequence was completed.

Judgement Criterion

- Engine coolant temperature sensor output voltage has continued to be 0.1 volt or lower for 2 seconds.

FAIL-SAFE AND BACKUP FUNCTION

- Control as if the engine coolant temperature is 80 °C.

OBD-II DRIVE CYCLE PATTERN

Refer to Diagnostic Function –OBD-II Drive Cycle – Pattern 23 [P.13A-9](#).

TROUBLESHOOTING HINTS (The most likely causes for this code to be set are:)

- Engine coolant temperature sensor failed.
- Shorted engine coolant temperature sensor circuit, or connector damage.
- ECM failed.

DIAGNOSIS

Required Special Tools:

- MB991958: Scan Tool (M.U.T.-III Sub Assembly)
 - MB991824: V.C.I.
 - MB991827: USB Cable
 - MB991910: Main Harness A

STEP 1. Using scan tool MB991958, check data list item 6: Engine Coolant Temperature Sensor.

⚠ CAUTION

To prevent damage to scan tool MB991958, always turn the ignition switch to the "LOCK" (OFF) position before connecting or disconnecting scan tool MB991958.

- (1) Connect scan tool MB991958 to the data link connector.
- (2) Turn the ignition switch to the "ON" position.
- (3) Set scan tool MB991958 to the data reading mode for item 6, Engine Coolant Temperature Sensor.
 - The engine coolant temperature and temperature shown with the scan tool should approximately match.
- (4) Turn the ignition switch to the "LOCK" (OFF) position.

Q: Is the sensor operating properly?

YES : It can be assumed that this malfunction is intermittent. Refer to GROUP 00, How to Use Troubleshooting/Inspection Service Points –How to Cope with Intermittent Malfunctions [P.00-15](#).

NO : Go to Step 2.

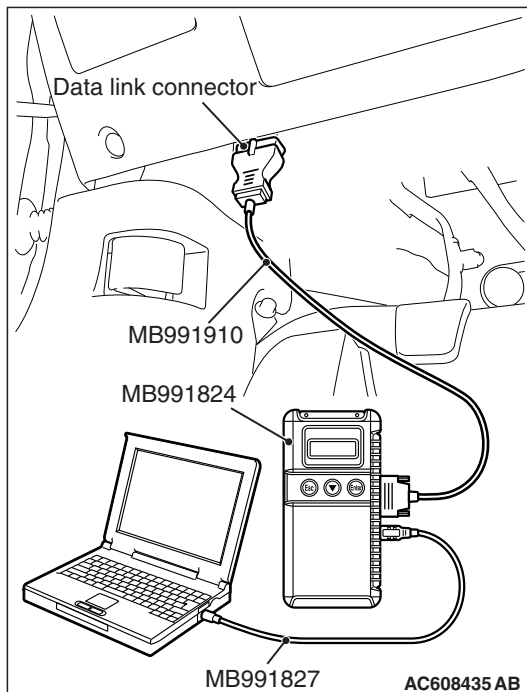

STEP 2. Check harness connector B-08 at the engine coolant temperature sensor for damage.

Q: Is the harness connector in good condition?

YES : Go to Step 3.

NO : Repair or replace it. Refer to GROUP 00E, Harness Connector Inspection [P.00E-2](#). Then go to Step 6.

STEP 3. Check for short circuit to ground between engine coolant temperature sensor connector B-08 (terminal No. 1) and ECM connector B-09 (terminal No. 26).

Q: Is the harness wire in good condition?

YES : Go to Step 4.

NO : Repair it. Then go to Step 6.

STEP 4. Check harness connector B-09 at ECM for damage.

Q: Is the harness connector in good condition?

YES : Go to Step 5.

NO : Repair or replace it. Refer to GROUP 00E, Harness Connector Inspection [P.00E-2](#). Then go to Step 6.

STEP 5. Check the engine coolant temperature sensor.

Refer to Engine Coolant Temperature Sensor Check

[P.13A-875](#).

Q: Is the engine coolant temperature sensor normal?

YES : Replace the ECM. When the ECM is replaced, register the ID code. Refer to GROUP 42B, ID Code Registration Necessity Judgment Table <Vehicles with KOS> [P.42B-11](#) or GROUP 42C, ID Codes Registration Judgment Table <Vehicles with WCM> [P.42C-9](#). Then go to Step 6.

NO : Replace the engine coolant temperature sensor. Then go to Step 6.

STEP 6. Test the OBD-II drive cycle.

(1) Carry out a test drive with the drive cycle pattern. Refer to Diagnostic Function –OBD-II Drive Cycle –Pattern 23 [P.13A-9](#).

(2) Check the diagnostic trouble code (DTC).

Q: Is DTC P0117 set?

YES : Retry the troubleshooting.

NO : The inspection is complete.

DTC P0118: Engine Coolant Temperature Circuit High Input

ENGINE COOLANT TEMPERATURE SENSOR CIRCUIT

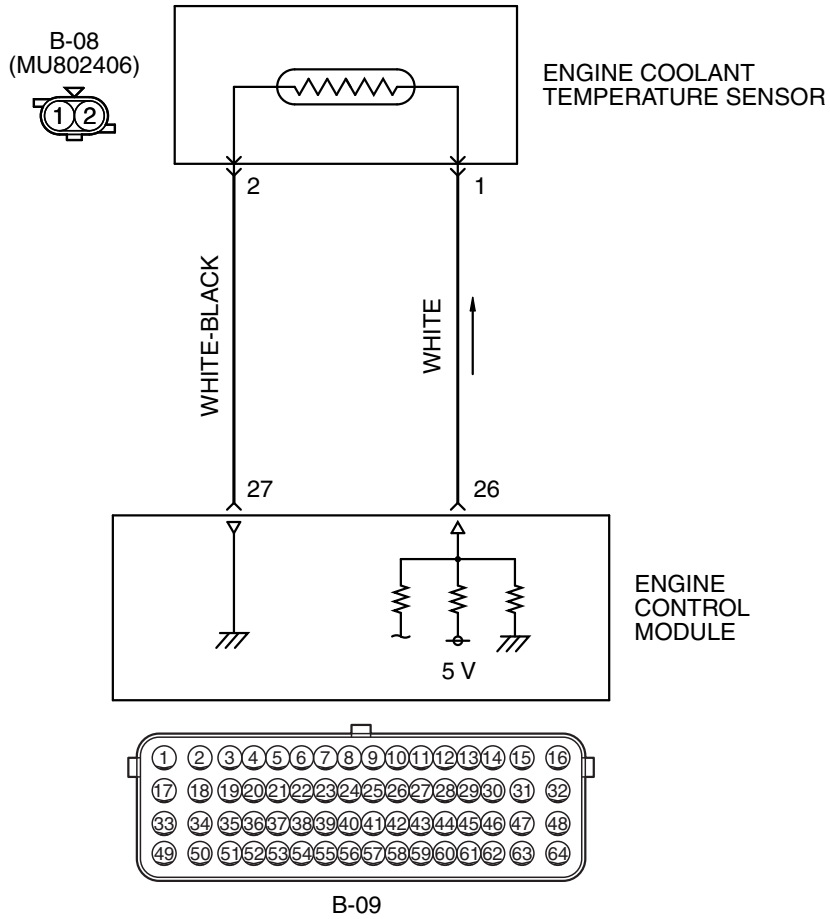

AK603948 AD

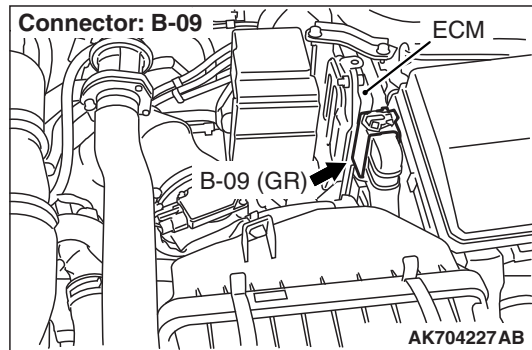
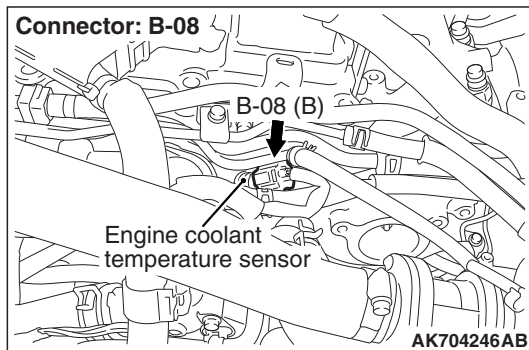

CIRCUIT OPERATION

- 5-volt voltage is applied to the engine coolant temperature sensor output terminal (terminal No. 1) from the ECM (terminal No. 26) via the resistor in the ECM. The ground terminal (terminal No. 2) is grounded with ECM (terminal No. 27).
- The engine coolant temperature sensor is a negative temperature coefficient type of resistor. It has the characteristic that when the engine coolant temperature rises the resistance decreases.
- The engine coolant temperature sensor output voltage increases when the resistance increases and decreases when the resistance decreases.

TECHNICAL DESCRIPTION

- The engine coolant temperature sensor converts the engine coolant temperature to a voltage and outputs it.
- The ECM checks whether this voltage is within a specified range.

DESCRIPTIONS OF MONITOR METHODS

Engine coolant temperature sensor output voltage is out of specified range.

MONITOR EXECUTION

Continuous

MONITOR EXECUTION CONDITIONS (Other monitor and Sensor)

Other Monitor (There is no temporary DTC stored in memory for the item monitored below)

- Not applicable

Sensor (The sensor below is determined to be normal)

- Not applicable

DTC SET CONDITIONS

Logic Flow Chart

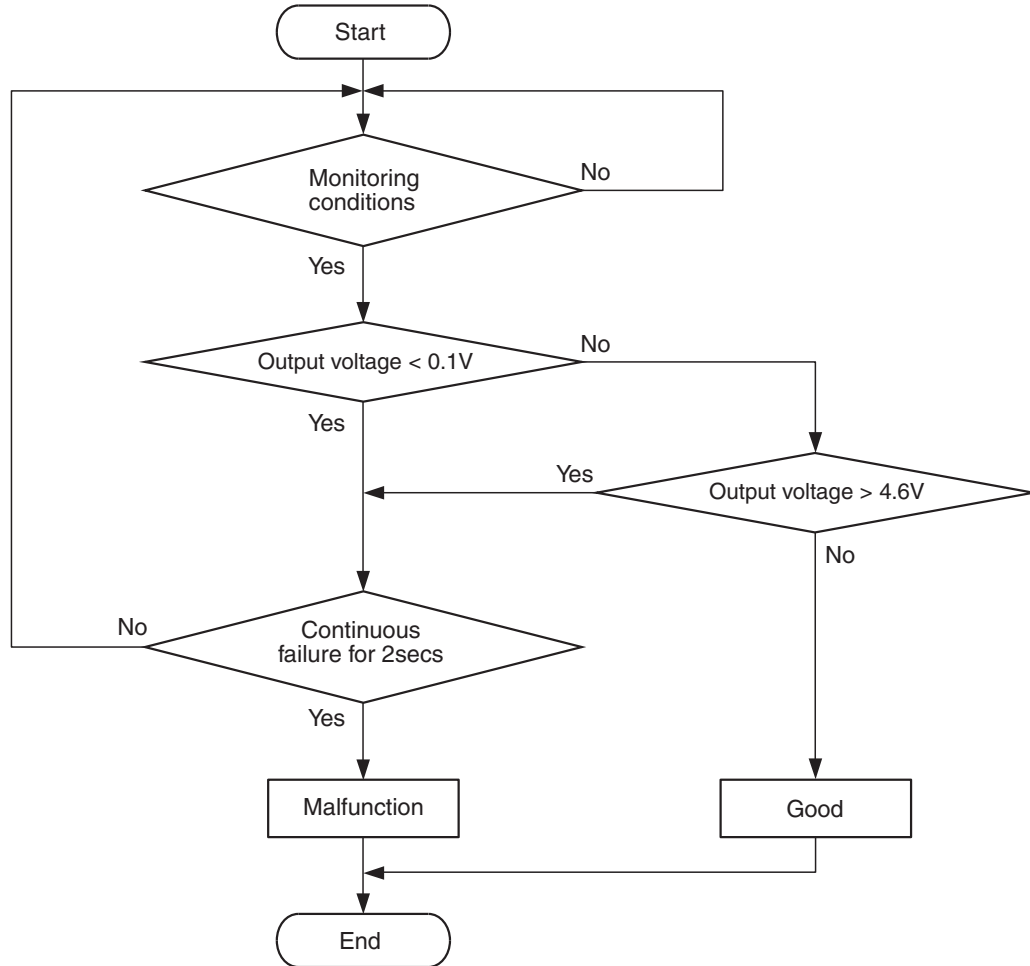

AK604317

Check Condition

- 2 seconds or more have passed since the engine starting sequence was completed.

Judgement Criterion

- Engine coolant temperature sensor output voltage has continued to be 4.6 volts or higher for 2 seconds.

FAIL-SAFE AND BACKUP FUNCTION

- Control as if the engine coolant temperature is 80 °C.

OBD-II DRIVE CYCLE PATTERN

Refer to Diagnostic Function-OBD-II Drive Cycle-Pattern 23 [P.13A-9](#).

TROUBLESHOOTING HINTS (The most likely causes for this code to be set are:)

- Engine coolant temperature sensor failed.
- Open engine coolant temperature sensor circuit, or connector damage.
- ECM failed.

DIAGNOSIS

Required Special Tools:

- MB991958: Scan Tool (M.U.T.-III Sub Assembly)
 - MB991824: V.C.I.
 - MB991827: USB Cable
 - MB991910: Main Harness A
- MB992110: Power Plant ECU Check Harness

STEP 1. Using scan tool MB991958, check data list item 6: Engine Coolant Temperature Sensor.

⚠ CAUTION

To prevent damage to scan tool MB991958, always turn the ignition switch to the "LOCK" (OFF) position before connecting or disconnecting scan tool MB991958.

- (1) Connect scan tool MB991958 to the data link connector.
- (2) Turn the ignition switch to the "ON" position.
- (3) Set scan tool MB991958 to the data reading mode for item 6, Engine Coolant Temperature Sensor.
 - The engine coolant temperature and temperature shown with the scan tool should approximately match.
- (4) Turn the ignition switch to the "LOCK" (OFF) position.

Q: Is the sensor operating properly?

YES : It can be assumed that this malfunction is intermittent. Refer to GROUP 00, How to Use Troubleshooting/Inspection Service Points –How to Cope with Intermittent Malfunctions P.00-15.

NO : Go to Step 2.

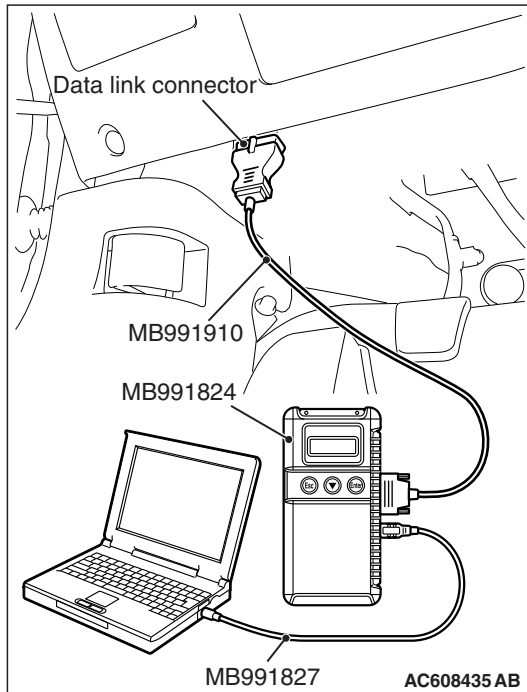

STEP 2. Check harness connector B-08 at the engine coolant temperature sensor for damage.

Q: Is the harness connector in good condition?

YES : Go to Step 3.

NO : Repair or replace it. Refer to GROUP 00E, Harness Connector Inspection P.00E-2. Then go to Step 10.

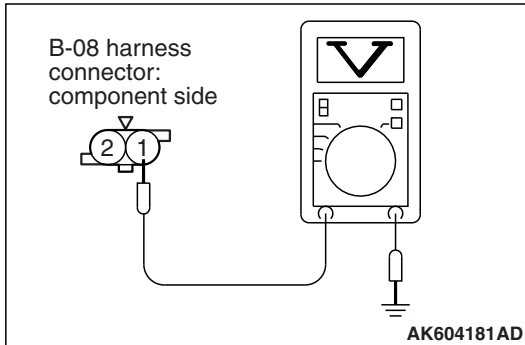

STEP 3. Measure the sensor supply voltage at engine coolant temperature sensor harness side connector B-08.

- (1) Disconnect the connector B-08 and measure at the harness side.
- (2) Turn the ignition switch to the "ON" position.
- (3) Measure the voltage between terminal No. 1 and ground.
 - Voltage should be between 4.5 and 4.9 volts.
- (4) Turn the ignition switch to the "LOCK" (OFF) position.

Q: Is the measured voltage between 4.5 and 4.9 volts?

YES : Go to Step 6.

NO : Go to Step 4.

STEP 4. Check harness connector B-09 at ECM for damage.

Q: Is the harness connector in good condition?

YES : Go to Step 5.

NO : Repair or replace it. Refer to GROUP 00E, Harness Connector Inspection [P.00E-2](#). Then go to Step 10.

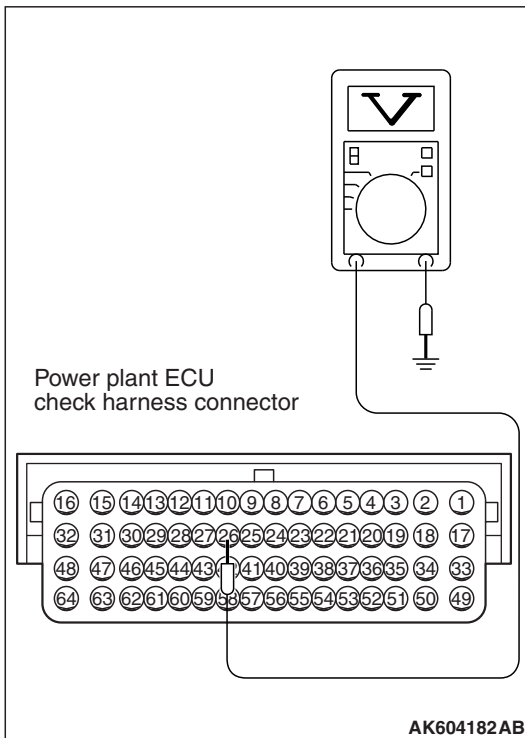
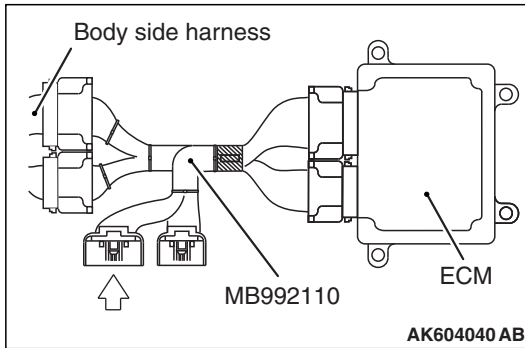

STEP 5. Measure the sensor supply voltage at ECM connector B-09 by using power plant ECU check harness special tool MB992110.

- (1) Disconnect all ECM connectors. Connect the power plant ECU check harness special tool MB992110 between the separated connectors.
- (2) Disconnect the engine coolant temperature sensor connector B-08.
- (3) Turn the ignition switch to the "ON" position.

- (4) Measure the voltage between terminal No. 26 and ground.
 - Voltage should be between 4.5 and 4.9 volts.
- (5) Turn the ignition switch to the "LOCK" (OFF) position.

Q: Is the measured voltage between 4.5 and 4.9 volts?

YES : Repair harness wire between engine coolant temperature sensor connector B-08 (terminal No. 1) and ECM connector B-09 (terminal No. 26) because of open circuit. Then go to Step 10.

NO : Replace the ECM. When the ECM is replaced, register the ID code. Refer to GROUP 42B, ID Code Registration Necessity Judgment Table <Vehicles with KOS> P.42B-11 or GROUP 42C, ID Codes Registration Judgment Table <Vehicles with WCM> P.42C-9. Then go to Step 10.

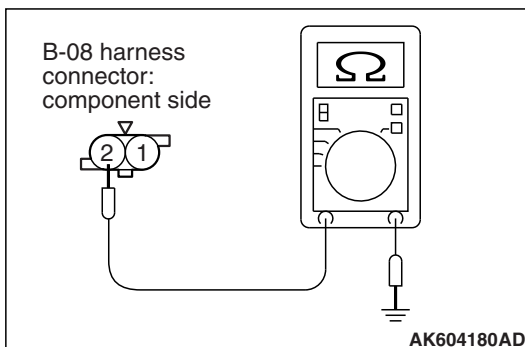

STEP 6. Check the continuity at engine coolant temperature sensor harness side connector B-08.

- (1) Disconnect the connector B-08 and measure at the harness side.
- (2) Check for the continuity between terminal No. 2 and ground.
 - Continuity (2 ohms or less)

Q: Does continuity exist?

YES : Go to Step 9.

NO : Go to Step 7.

STEP 7. Check harness connector B-09 at ECM for damage.

Q: Is the harness connector in good condition?

YES : Go to Step 8.

NO : Repair or replace it. Refer to GROUP 00E, Harness Connector Inspection [P.00E-2](#). Then go to Step 10.

STEP 8. Check for open circuit between engine coolant sensor connector B-08 (terminal No. 2) and ECM connector B-09 (terminal No. 27).

Q: Is the harness wire in good condition?

YES : Replace the ECM. When the ECM is replaced, register the ID code. Refer to GROUP 42B, ID Code Registration Necessity Judgment Table <Vehicles with KOS> [P.42B-11](#) or GROUP 42C, ID Codes Registration Judgment Table <Vehicles with WCM> [P.42C-9](#). Then go to Step 10.

NO : Repair it. Then go to Step 10.

STEP 9. Check the engine coolant temperature sensor.

Refer to Engine Coolant Temperature Sensor Check [P.13A-875](#).

Q: Is the engine coolant temperature sensor normal?

YES : Replace the ECM. When the ECM is replaced, register the ID code. Refer to GROUP 42B, ID Code Registration Necessity Judgment Table <Vehicles with KOS> [P.42B-11](#) or GROUP 42C, ID Codes Registration Judgment Table <Vehicles with WCM> [P.42C-9](#). Then go to Step 10.

NO : Replace the engine coolant temperature sensor. Then go to Step 10.

STEP 10. Test the OBD-II drive cycle.

(1) Carry out a test drive with the drive cycle pattern. Refer to Diagnostic Function –OBD-II Drive Cycle –Pattern 23 [P.13A-9](#).

(2) Check the diagnostic trouble code (DTC).

Q: Is DTC P0118 set?

YES : Retry the troubleshooting.

NO : The inspection is complete.

DTC P0122: Throttle Position Sensor (main) Circuit Low Input

THROTTLE POSITION SENSOR (MAIN) CIRCUIT

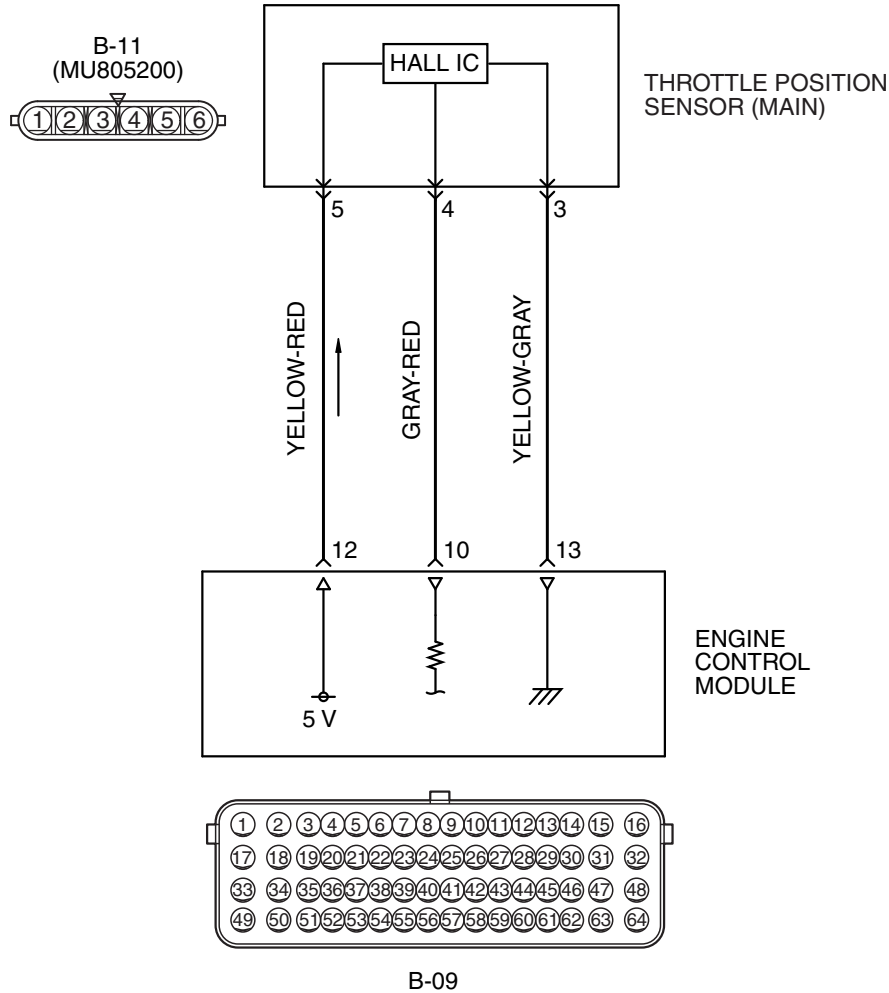

AK603950AD

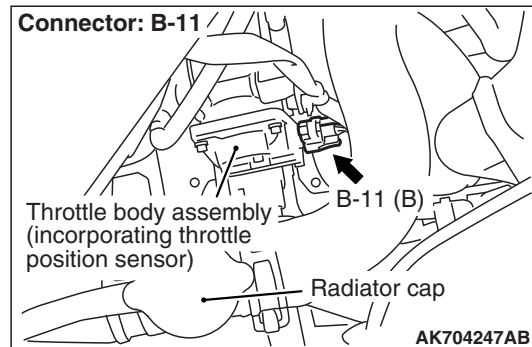
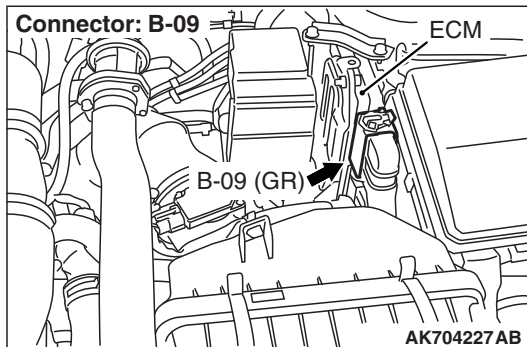

CIRCUIT OPERATION

- A 5-volt power supply is applied on the throttle position sensor (main) power terminal (terminal No. 5) from the ECM (terminal No. 12).
- A voltage that is according to the throttle opening angle is sent to the ECM (terminal No. 10) from the throttle position sensor (main) output terminal (terminal No. 4).

- The ground terminal (terminal No. 3) is grounded with ECM (terminal No. 13).

TECHNICAL DESCRIPTION

- The throttle position sensor (main) outputs voltage which corresponds to the throttle valve opening angle.
- The ECM checks whether the voltage is within a specified range.

DESCRIPTIONS OF MONITOR METHODS

Throttle position sensor (main) output voltage is out of specified range.

DTC SET CONDITIONS

Logic Flow Chart

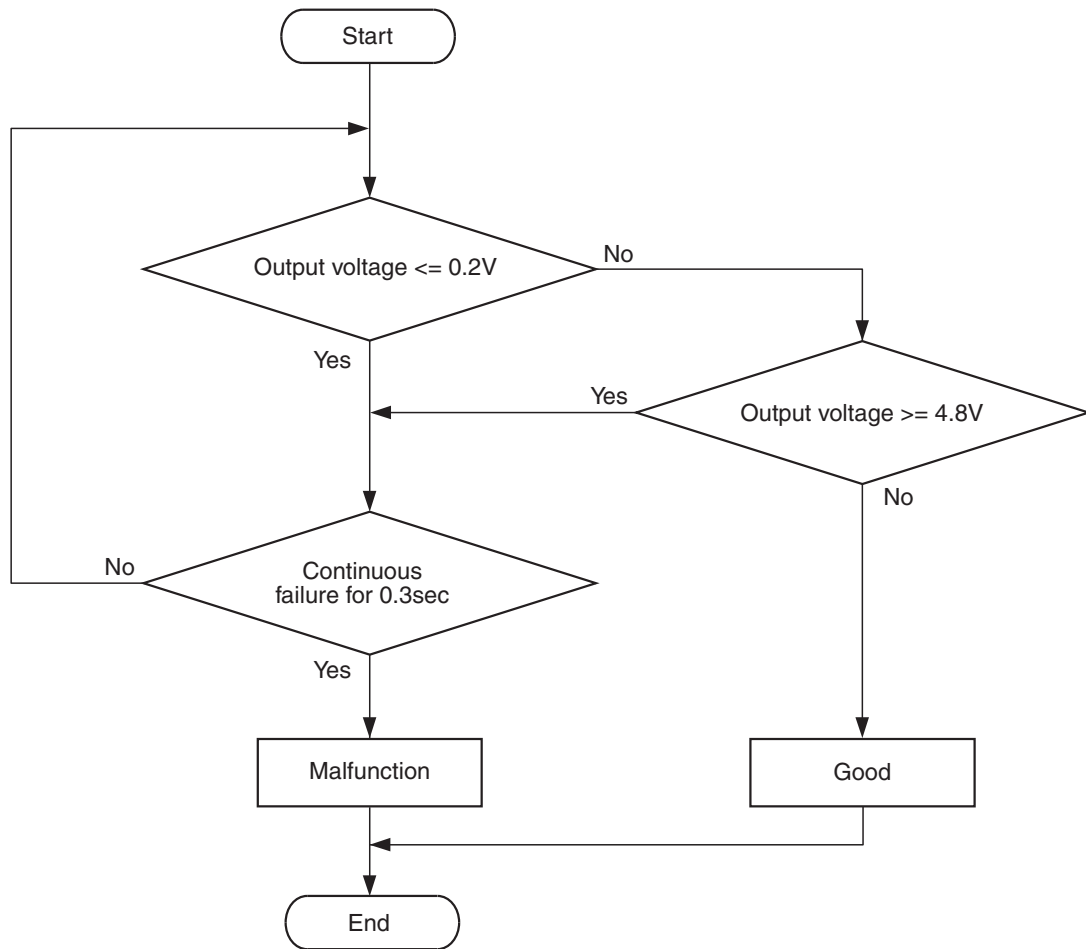

MONITOR EXECUTION

Continuous

**MONITOR EXECUTION CONDITIONS
(Other monitor and Sensor)**

Other Monitor (There is no temporary DTC stored in memory for the item monitored below)

- Not applicable

Sensor (The sensor below is determined to be normal)

- Not applicable

Check Condition

- Ignition switch is "ON" position.

Judgement Criterion

- Throttle position sensor (main) output voltage should be 0.2 volt or less for 0.3 second.

FAIL-SAFE AND BACKUP FUNCTION

- Throttle opening degree is restricted.
- Throttle opening degree position is in default position if throttle position sensor (sub) fails.

OBD-II DRIVE CYCLE PATTERN

None.

TROUBLESHOOTING HINTS (The most likely causes for this code to be set are:)

- Throttle position sensor failed.
- Shorted throttle position sensor (main) circuit, harness damage, or connector damage.
- ECM failed.

DIAGNOSIS

Required Special Tools:

- MB991958: Scan tool (M.U.T.-III Sub Assembly)
 - MB991824: V.C.I.
 - MB991827: USB Cable
 - MB991910: Main Harness A
- MB991658: Test Harness

STEP 1. Using scan tool MB991958, check data list item 13: Throttle Position Sensor (main).

CAUTION

To prevent damage to scan tool MB991958, always turn the ignition switch to the "LOCK" (OFF) position before connecting or disconnecting scan tool MB991958.

- (1) Connect scan tool MB991958 to the data link connector.
- (2) Turn the ignition switch to the "ON" position.
- (3) Detach the intake air hose at the throttle body.
- (4) Disconnect the connector of the throttle position sensor.
- (5) Use test harness special tool (MB991658) to connect only terminals No. 3, No. 4, No. 5, and No. 6.
- (6) Set scan tool MB991958 to the data reading mode for item 13, Throttle Position Sensor (main).
 - Output voltage should be between 0.3 and 0.7 volt when the throttle valve is fully closed with your finger.
 - Output voltage should be 4.0 volts or more when the throttle valve is fully open with your finger.
- (7) Turn the ignition switch to the "LOCK" (OFF) position.

Q: Is the sensor operating properly?

YES : It can be assumed that this malfunction is intermittent. Refer to GROUP 00, How to Use Troubleshooting/Inspection Service Points –How to Cope with Intermittent Malfunctions P.00-15.

NO : Go to Step 2.

STEP 2. Check harness connector B-11 at throttle position sensor and harness connector B-09 at ECM for damage.

Q: Is the harness connector in good condition?

YES : Go to Step 3.

NO : Repair or replace it. Refer to GROUP 00E, Harness Connector Inspection P.00E-2. Then go to Step 7.

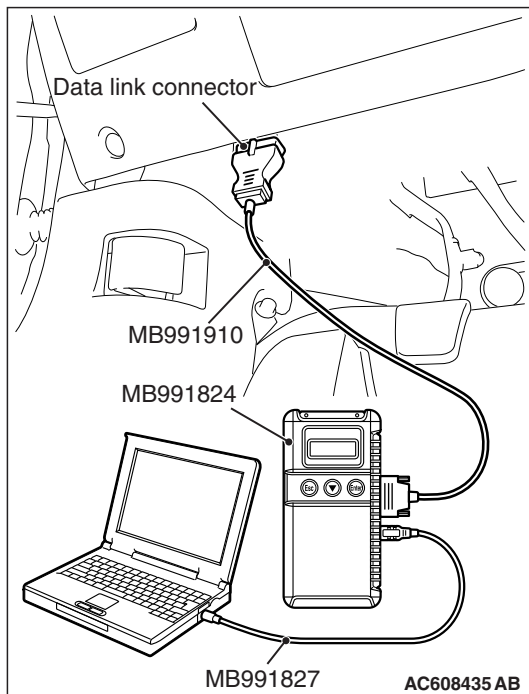

STEP 3. Check for harness damage between throttle position sensor connector B-11 (terminal No. 5) and ECM connector B-09 (terminal No. 12).

Q: Is the harness wire in good condition?

YES : Go to Step 4.

NO : Repair it. Then go to Step 7.

STEP 4. Check for short circuit to ground and harness damage between throttle position sensor connector B-11 (terminal No. 4) and ECM connector B-09 (terminal No. 10).

Q: Is the harness wire in good condition?

YES : Go to Step 5.

NO : Repair it. Then go to Step 7.

STEP 5. Using scan tool MB991958, check data list item 13: Throttle Position Sensor (main).

- (1) Turn the ignition switch to the "ON" position.
- (2) Detach the intake air hose at the throttle body.
- (3) Disconnect the connector of the throttle position sensor.
- (4) Use test harness special tool (MB991658) to connect only terminals No. 3, No. 4, No. 5, and No. 6.
- (5) Set scan tool MB991958 to the data reading mode for item 13, Throttle Position Sensor (main).
 - Output voltage should be between 0.3 and 0.7 volt when the throttle valve is fully closed with your finger.
 - Output voltage should be 4.0 volts or more when the throttle valve is fully open with your finger.
- (6) Turn the ignition switch to the "LOCK" (OFF) position.

Q: Is the sensor operating properly?

YES : It can be assumed that this malfunction is intermittent. Refer to GROUP 00, How to Use Troubleshooting/Inspection Service Points –How to Cope with Intermittent Malfunctions [P.00-15](#).

NO : Go to Step 6.

STEP 6. Replace the throttle body assembly.

- (1) Replace the throttle body assembly.
- (2) Turn the ignition switch to the "ON" position.
- (3) After the DTC has been deleted, read the DTC again.
- (4) Turn the ignition switch to the "LOCK" (OFF) position.

Q: Is DTC P0122 set?

YES : Replace the ECM. When the ECM is replaced, register the ID code. Refer to GROUP 42B, Diagnosis –ID Code Registration Judgment Table <Vehicles with KOS> [P.42B-11](#) or GROUP 42C, Diagnosis –ID Codes Registration Judgment Table <Vehicles with WCM> [P.42C-9](#). Then go to Step 7.

NO : The inspection is complete.

STEP 7. Using scan tool MB991958, read the diagnostic trouble code (DTC).

- (1) Turn the ignition switch to the "ON" position.
- (2) After the DTC has been deleted, read the DTC again.
- (3) Turn the ignition switch to the "LOCK" (OFF) position.

Q: Is DTC P0122 set?

- YES :** Retry the troubleshooting.
NO : The inspection is complete.

DTC P0123: Throttle Position Sensor (main) Circuit High Input

THROTTLE POSITION SENSOR (MAIN) CIRCUIT

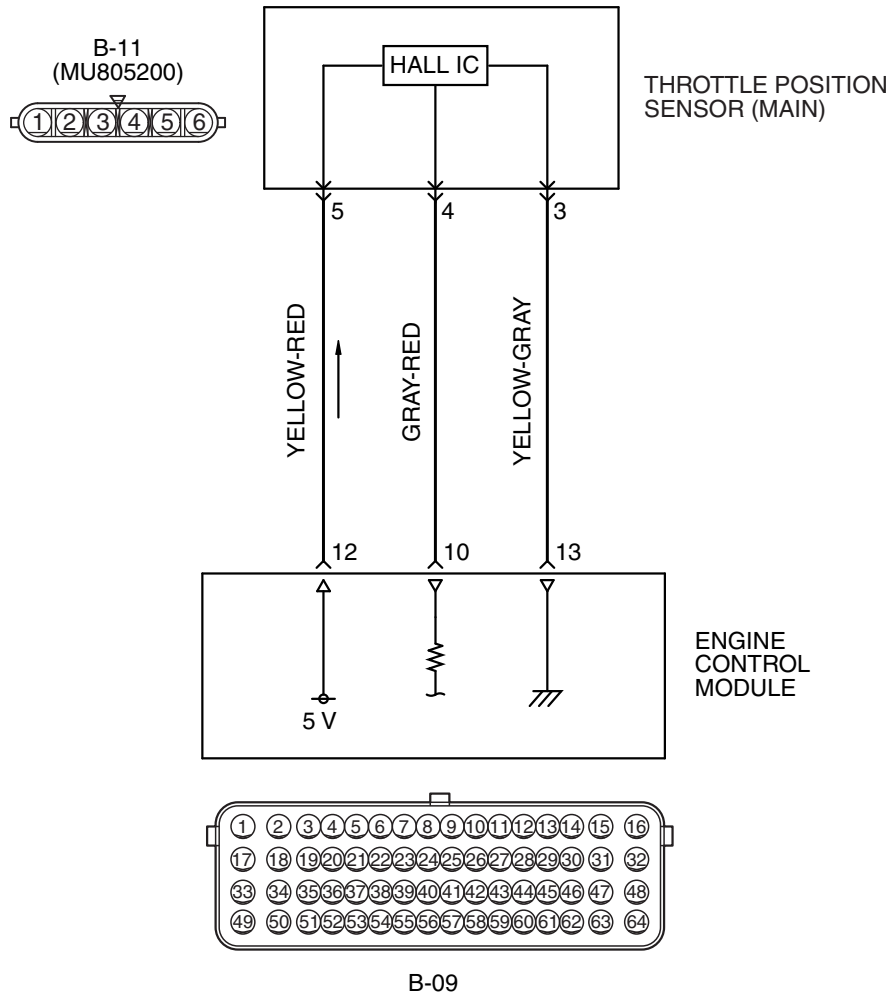

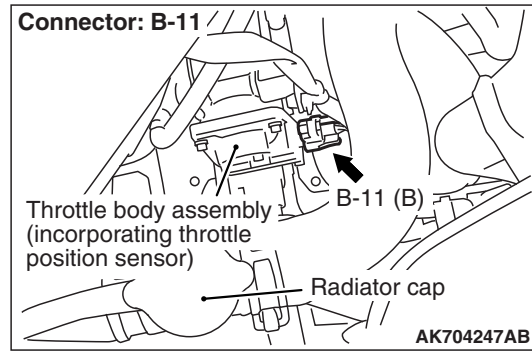
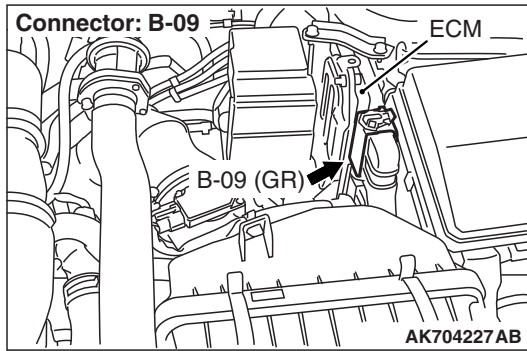

CIRCUIT OPERATION

- A 5-volt power supply is applied on the throttle position sensor (main) power terminal (terminal No. 5) from the ECM (terminal No. 12).
- A voltage that is according to the throttle opening angle is sent to the ECM (terminal No. 10) from the throttle position sensor (main) output terminal (terminal No. 4)
- The ground terminal (terminal No. 3) is grounded with ECM (terminal No. 13).

TECHNICAL DESCRIPTION

- The throttle position sensor (main) outputs voltage which corresponds to the throttle valve opening angle.
- The ECM checks whether the voltage is within a specified range.

DESCRIPTIONS OF MONITOR METHODS

Throttle position sensor (main) output voltage is out of specified range.

MONITOR EXECUTION

Continuous

MONITOR EXECUTION CONDITIONS (Other monitor and Sensor)

Other Monitor (There is no temporary DTC stored in memory for the item monitored below)

- Not applicable

Sensor (The sensor below is determined to be normal)

- Not applicable

DTC SET CONDITIONS

Logic Flow Chart

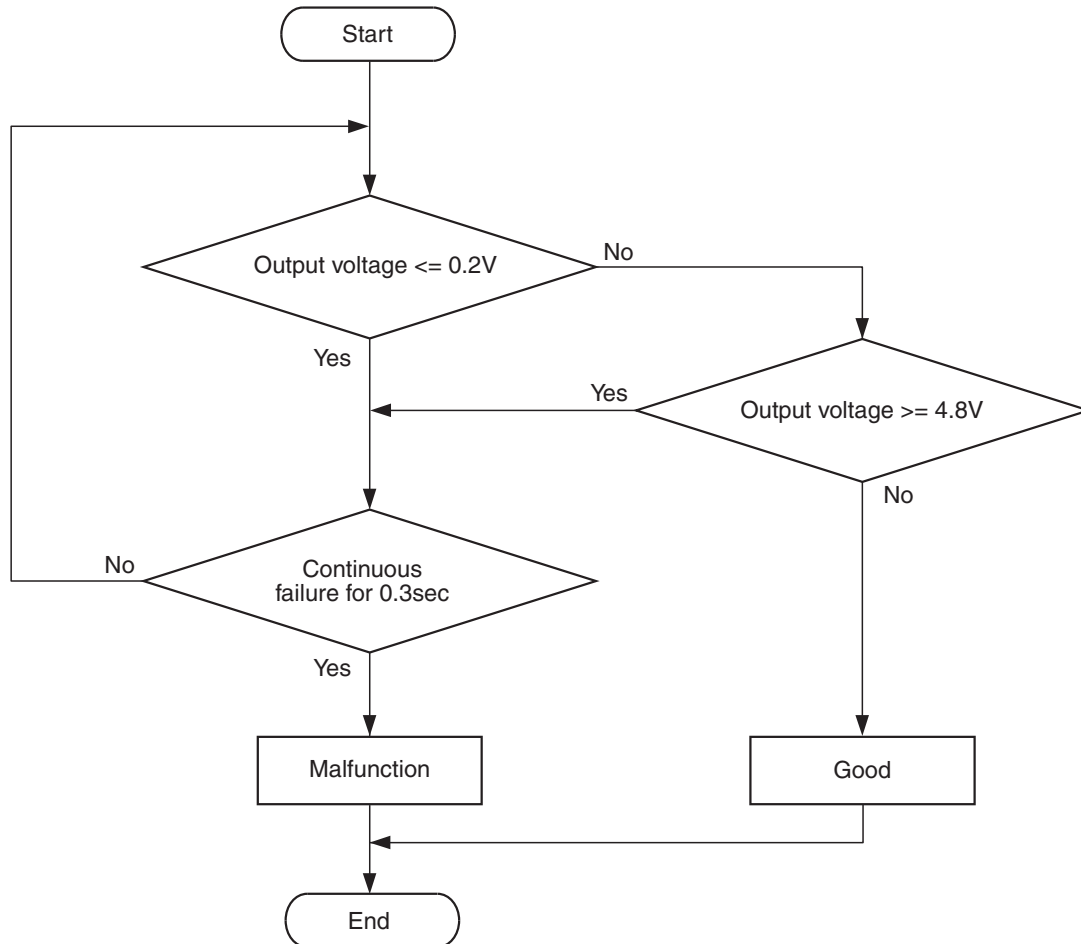

AK604318

Check Condition

- Ignition switch is "ON" position.

Judgement Criterion

- Throttle position sensor (main) output voltage should be 4.8 volts or more for 0.3 second.

FAIL-SAFE AND BACKUP FUNCTION

- Throttle opening degree is restricted.
- Throttle opening degree position is in default position if throttle position sensor (sub) fails.

OBD-II DRIVE CYCLE PATTERN

None.

TROUBLESHOOTING HINTS (The most likely causes for this code to be set are:)

- Throttle position sensor failed.
- Open or shorted throttle position sensor (main) circuit, harness damage, or connector damage.
- ECM failed.

DIAGNOSIS

Required Special Tools:

- MB991958: Scan tool (M.U.T.-III Sub Assembly)
 - MB991824: V.C.I.
 - MB991827: USB Cable
 - MB991910: Main Harness A
- MB991658: Test Harness

STEP 1. Using scan tool MB991958, check data list item 13: Throttle Position Sensor (main).

⚠ CAUTION

To prevent damage to scan tool MB991958, always turn the ignition switch to the "LOCK" (OFF) position before connecting or disconnecting scan tool MB991958.

- (1) Connect scan tool MB991958 to the data link connector.
- (2) Turn the ignition switch to the "ON" position.
- (3) Detach the intake air hose at the throttle body.
- (4) Disconnect the connector of the throttle position sensor.
- (5) Use test harness special tool (MB991658) to connect only terminals No. 3, No. 4, No. 5, and No. 6.
- (6) Set scan tool MB991958 to the data reading mode for item 13, Throttle Position Sensor (main).
 - Output voltage should be between 0.3 and 0.7 volt when the throttle valve is fully closed with your finger.
 - Output voltage should be 4.0 volts or more when the throttle valve is fully open with your finger.
- (7) Turn the ignition switch to the "LOCK" (OFF) position.

Q: Is the sensor operating properly?

YES : It can be assumed that this malfunction is intermittent. Refer to GROUP 00, How to Use Troubleshooting/Inspection Service Points –How to Cope with Intermittent Malfunctions [P.00-15](#).

NO : Go to Step 2.

STEP 2. Check harness connector B-11 at throttle position sensor for damage.

Q: Is the harness connector in good condition?

YES : Go to Step 3.

NO : Repair or replace it. Refer to GROUP 00E, Harness Connector Inspection [P.00E-2](#). Then go to Step 14.

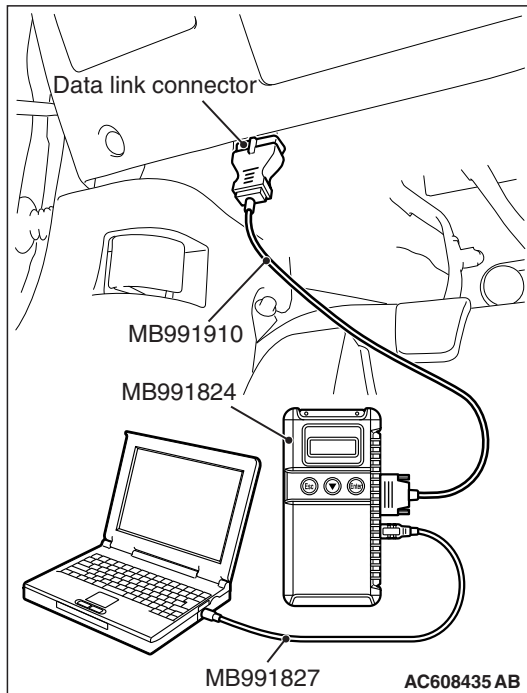

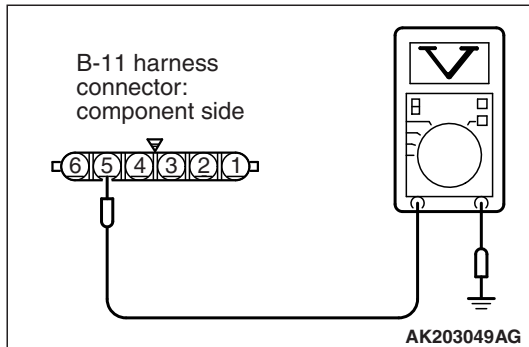

STEP 3. Measure the sensor supply voltage at throttle position sensor harness side connector B-11.

- (1) Disconnect the connector B-11 and measure at the harness side.
- (2) Turn the ignition switch to the "ON" position.
- (3) Measure the voltage between terminal No. 5 and ground.
 - Voltage should be between 4.9 and 5.1 volts.
- (4) Turn the ignition switch to the "LOCK" (OFF) position.

Q: Is the measured voltage between 4.9 and 5.1 volts?

YES : Go to Step 6.

NO : Go to Step 4.

STEP 4. Check harness connector B-09 at ECM for damage.

Q: Is the harness connector in good condition?

YES : Go to Step 5.

NO : Repair or replace it. Refer to GROUP 00E, Harness Connector Inspection [P.00E-2](#). Then go to Step 14.

STEP 5. Check for open circuit and short circuit to ground between throttle position sensor connector B-11 (terminal No. 5) and ECM connector B-09 (terminal No. 12).

Q: Is the harness wire in good condition?

YES : Go to Step 9.

NO : Repair it. Then go to Step 14.

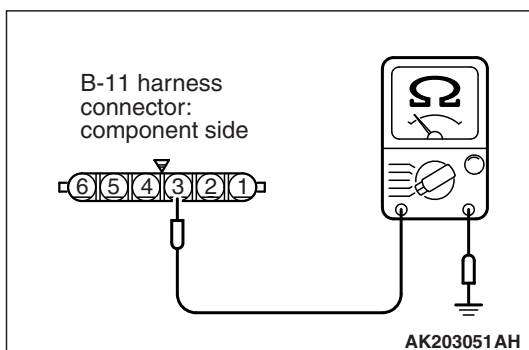

STEP 6. Check the continuity at throttle position sensor harness side connector B-11.

- (1) Disconnect the connector B-11 and measure at the harness side.
- (2) Measure the continuity between terminal No. 3 and ground
 - Continuity (2 ohms or less)

Q: Does continuity exist?

YES : Go to Step 10.

NO : Go to Step 7.

STEP 7. Check harness connector B-09 at ECM for damage.

Q: Is the harness connector in good condition?

YES : Go to Step 8.

NO : Repair or replace it. Refer to GROUP 00E, Harness Connector Inspection [P.00E-2](#). Then go to Step 14.

STEP 8. Check for open circuit and harness damage between throttle position sensor connector B-11 (terminal No. 3) and ECM connector B-09 (terminal No. 13).

Q: Is the harness wire in good condition?

YES : Go to Step 9.

NO : Repair it. Then go to Step 14.

STEP 9. Using scan tool MB991958, check data list item 13: Throttle Position Sensor (main).

- (1) Turn the ignition switch to the "ON" position.
- (2) Detach the intake air hose at the throttle body.
- (3) Disconnect the connector of the throttle position sensor.
- (4) Use test harness special tool (MB991658) to connect only terminals No. 3, No. 4, No. 5, and No. 6.
- (5) Set scan tool MB991958 to the data reading mode for item 13, Throttle Position Sensor (main).
 - Output voltage should be between 0.3 and 0.7 volt when the throttle valve is fully closed with your finger.
 - Output voltage should be 4.0 volts or more when the throttle valve is fully open with your finger.
- (6) Turn the ignition switch to the "LOCK" (OFF) position.

Q: Is the sensor operating properly?

YES : It can be assumed that this malfunction is intermittent. Refer to GROUP 00, How to Use Troubleshooting/Inspection Service Points –How to Cope with Intermittent Malfunctions [P.00-15](#).

NO : Replace the ECM. When the ECM is replaced, register the ID code. Refer to GROUP 42B, Diagnosis –ID Code Registration Judgment Table <Vehicles with KOS> [P.42B-11](#) or GROUP 42C, Diagnosis –ID Codes Registration Judgment Table <Vehicles with WCM> [P.42C-9](#). Then go to Step 14.

STEP 10. Check harness connector B-09 at ECM for damage.

Q: Is the harness connector in good condition?

YES : Go to Step 11.

NO : Repair or replace it. Refer to GROUP 00E, Harness Connector Inspection [P.00E-2](#). Then go to Step 14.

STEP 11. Check for harness damage between throttle position sensor connector B-11 (terminal No. 5) and ECM connector B-09 (terminal No. 12).

Q: Is the harness wire in good condition?

YES : Go to Step 12.

NO : Repair it. Then go to Step 14.

STEP 12. Check for open circuit, short circuit to ground and harness damage between throttle position sensor connector B-11 (terminal No. 4) and ECM connector B-09 (terminal No. 10).

Q: Is the harness wire in good condition?

YES : Go to Step 13.

NO : Repair it. Then go to Step 14.

STEP 13. Replace the throttle body assembly.

(1) Replace the throttle body assembly.

(2) Turn the ignition switch to the "ON" position.

(3) After the DTC has been deleted, read the DTC again.

(4) Turn the ignition switch to the "LOCK" (OFF) position.

Q: Is DTC P0123 set?

YES : Replace the ECM. When the ECM is replaced, register the ID code. Refer to GROUP 42B, Diagnosis –ID Code Registration Judgment Table <Vehicles with KOS> [P.42B-11](#) or GROUP 42C, Diagnosis –ID Codes Registration Judgment Table <Vehicles with WCM> [P.42C-9](#). Then go to Step 14.

NO : The inspection is complete.

STEP 14. Using scan tool MB991958, read the diagnostic trouble code (DTC).

(1) Turn the ignition switch to the "ON" position.

(2) After the DTC has been deleted, read the DTC again.

(3) Turn the ignition switch to the "LOCK" (OFF) position.

Q: Is DTC P0123 set?

YES : Retry the troubleshooting.

NO : The inspection is complete.

DTC P0125: Insufficient Coolant Temperature for Closed Loop Fuel Control

ENGINE COOLANT TEMPERATURE SENSOR CIRCUIT

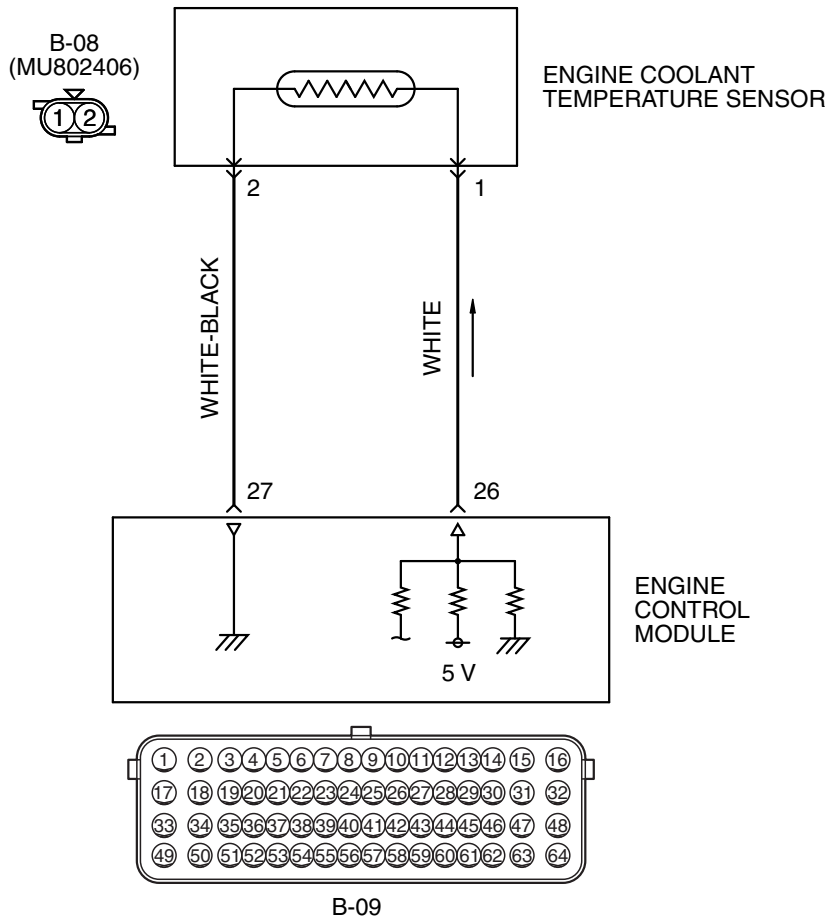

AK603948 AD

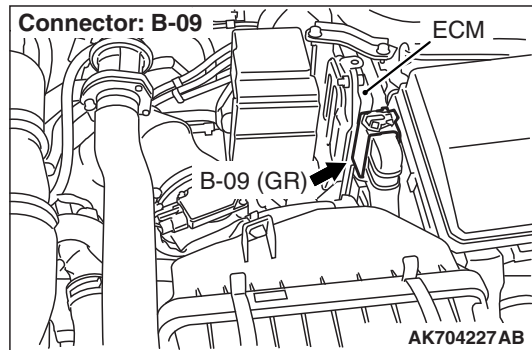
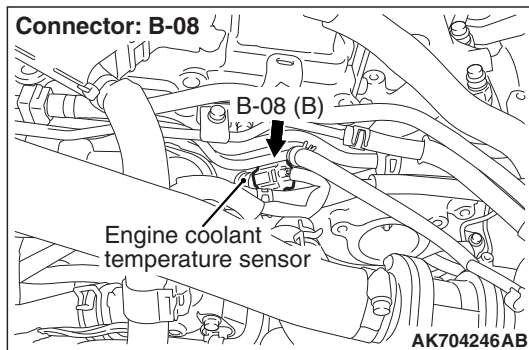

CIRCUIT OPERATION

- 5-volt voltage is applied to the engine coolant temperature sensor output terminal (terminal No. 1) from the ECM (terminal No. 26) via the resistor in the ECM. The ground terminal (terminal No. 2) is grounded with ECM (terminal No. 27).
- The engine coolant temperature sensor is a negative temperature coefficient type of resistor. It has the characteristic that when the engine coolant temperature rises the resistance decreases.
- The engine coolant temperature sensor output voltage increases when the resistance increases and decreases when the resistance decreases.

TECHNICAL DESCRIPTION

- The engine coolant temperature sensor converts the engine coolant temperature to a voltage and outputs it.
- The ECM checks whether this voltage is within a specified range.

DESCRIPTIONS OF MONITOR METHODS

- Engine coolant temperature sensor output voltage drops from over 40° C (104° F) to under 40° C (104° F) and keeps under 40° C (104° F) for 5 minutes.
- Engine coolant temperature sensor output voltage does not reach close loop enable temperature within specified period when engine coolant temperature sensor output voltage at engine start is under 7° C (45° F).

MONITOR EXECUTION

Continuous

MONITOR EXECUTION CONDITIONS (Other monitor and Sensor)

Other Monitor (There is no temporary DTC stored in memory for the item monitored below)

- Not applicable

Sensor (The sensor below is determined to be normal)

- Mass airflow sensor
- Intake air temperature sensor

DTC SET CONDITIONS <Range/Performance problem –drift>

Logic Flow Chart

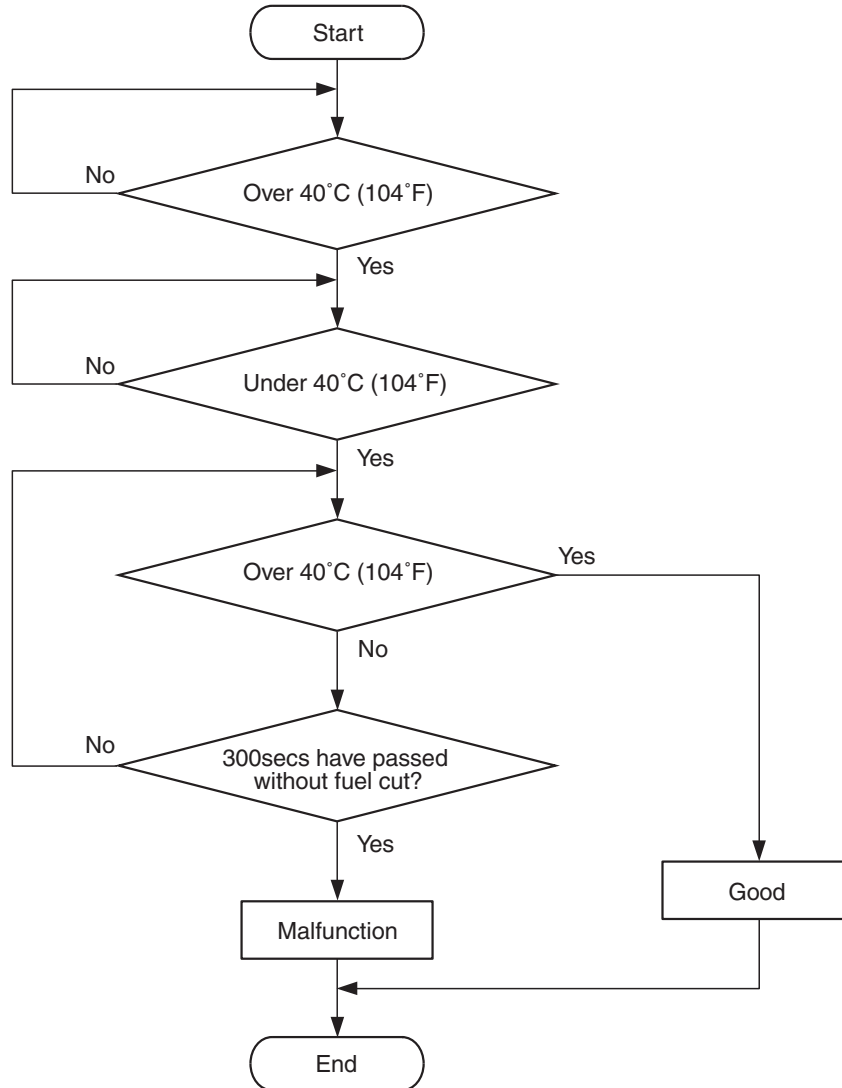

AK900355

Check Conditions, Judgement Criteria

- Engine coolant temperature decreases from higher than 40° C (104° F) to lower than 40° C (104° F).

- Then the engine coolant temperature is lower than 40° C (104° F) for 5 minutes.
- However, time is not counted when fuel is shut off.

DTC SET CONDITIONS <Range/Performance problem –low input (Time to reach closed loop temperature)>

Logic Flow Chart

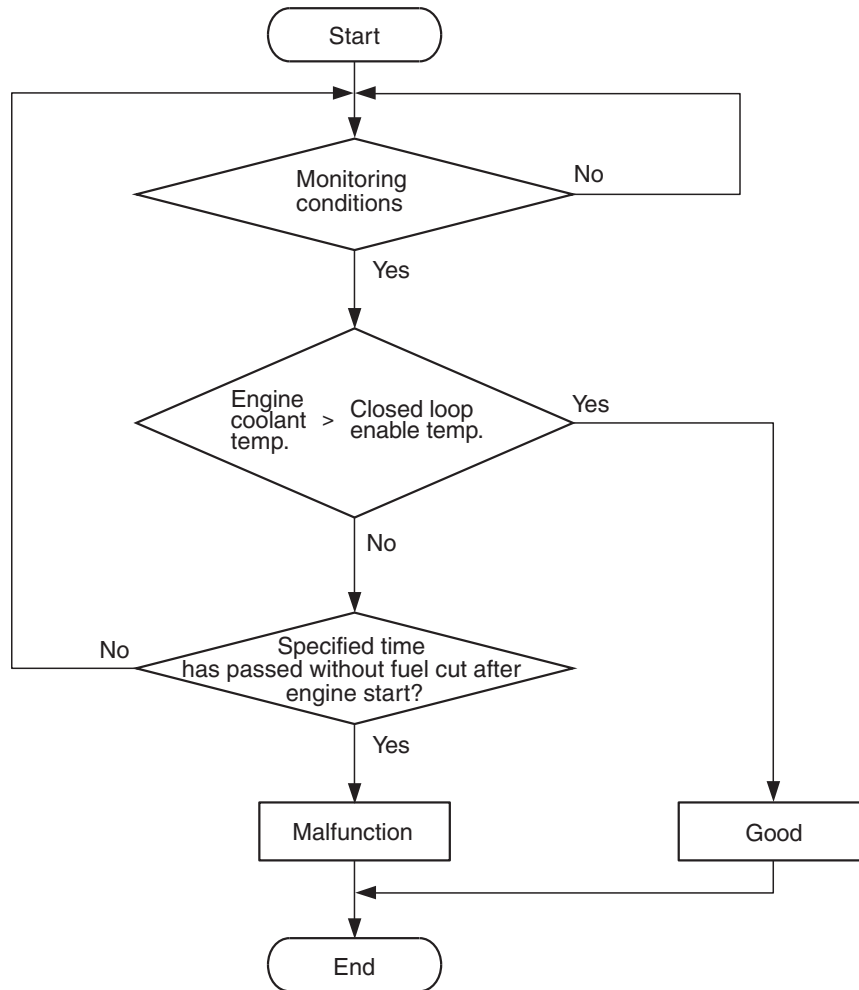

AK900354

Check Conditions, Judgement Criteria

- About 90 –300 seconds have passed for the engine coolant temperature to rise to about 7° C (45° F) after starting sequence was completed.
- However, time is not counted when fuel is shut off.

FAIL-SAFE AND BACKUP FUNCTION

- Control as if the engine coolant temperature is 80 °C.

OBD-II DRIVE CYCLE PATTERN

Refer to Diagnostic Function –OBD-II Drive Cycle – Pattern 8 P.13A-9.

TROUBLESHOOTING HINTS (The most likely causes for this code to be set are:)

- Engine coolant temperature sensor failed.
- Harness damage in engine coolant temperature sensor circuit or connector damage.
- ECM failed.

DIAGNOSIS**Required Special Tools:**

- MB991958: Scan Tool (M.U.T.-III Sub Assembly)
 - MB991824: V.C.I.
 - MB991827: USB Cable
 - MB991910: Main Harness A

STEP 1. Using scan tool MB991958, check data list item 6: Engine Coolant Temperature Sensor.**⚠ CAUTION**

To prevent damage to scan tool MB991958, always turn the ignition switch to the "LOCK" (OFF) position before connecting or disconnecting scan tool MB991958.

- (1) Connect scan tool MB991958 to the data link connector.
- (2) Turn the ignition switch to the "ON" position.
- (3) Set scan tool MB991958 to the data reading mode for item 6, Engine Coolant Temperature Sensor.
 - The engine coolant temperature and temperature shown with the scan tool should approximately match.
- (4) Turn the ignition switch to the "LOCK" (OFF) position.

Q: Is the sensor operating properly?

- YES :** It can be assumed that this malfunction is intermittent. Refer to GROUP 00, How to Use Troubleshooting/Inspection Service Points –How to Cope with Intermittent Malfunctions [P.00-15](#).
- NO :** Go to Step 2.

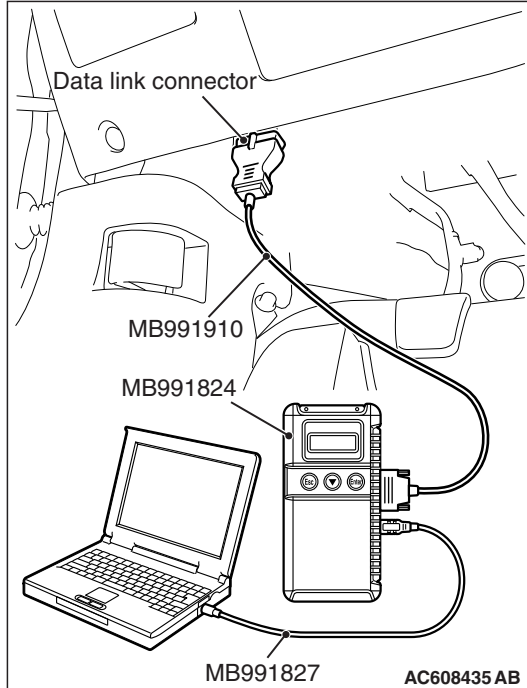

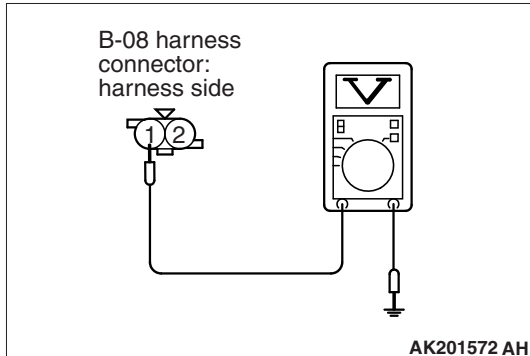

STEP 2. Measure the sensor output voltage at engine coolant temperature sensor connector B-08 by backprobing.

- (1) Do not disconnect the connector B-08.
- (2) Turn the ignition switch to the "ON" position.
- (3) Measure the voltage between terminal No. 1 and ground by backprobing.
 - When engine coolant temperature is -20°C (-4°F), voltage should be between 3.9 and 4.5 volts.
 - When engine coolant temperature is 0°C (32°F), voltage should be between 3.2 and 3.8 volts.
 - When engine coolant temperature is 20°C (68°F), voltage should be between 2.3 and 2.9 volts.
 - When engine coolant temperature is 40°C (104°F), voltage should be between 1.3 and 1.9 volts.
 - When engine coolant temperature is 60°C (140°F), voltage should be between 0.7 and 1.3 volts.
 - When engine coolant temperature is 80°C (176°F), voltage should be between 0.3 and 0.9 volt.
- (4) Turn the ignition switch to the "LOCK" (OFF) position.

Q: Is the measured voltage within the specified range?

- YES** : Go to Step 3.
NO : Go to Step 5.

STEP 3. Check harness connector B-08 at the engine coolant temperature sensor for damage.

Q: Is the harness connector in good condition?

- YES** : Go to Step 4.
NO : Repair or replace it. Refer to GROUP 00E, Harness Connector Inspection [P.00E-2](#). Then go to Step 14.

STEP 4. Using scan tool MB991958, check data list item 6: Engine Coolant Temperature Sensor.

- (1) Turn the ignition switch to the "ON" position.
- (2) Set scan tool MB991958 to the data reading mode for item 6, Engine Coolant Temperature Sensor.
 - The engine coolant temperature and temperature shown with the scan tool should approximately match.
- (3) Turn the ignition switch to the "LOCK" (OFF) position.

Q: Is the sensor operating properly?

- YES** : It can be assumed that this malfunction is intermittent. Refer to GROUP 00, How to Use Troubleshooting/Inspection Service Points –How to Cope with Intermittent Malfunctions [P.00-15](#).
- NO** : Replace the ECM. When the ECM is replaced, register the ID code. Refer to GROUP 42B, ID Code Registration Necessity Judgment Table <Vehicles with KOS> [P.42B-11](#) or GROUP 42C, ID Codes Registration Judgment Table <Vehicles with WCM> [P.42C-9](#). Then go to Step 14.

STEP 5. Check harness connector B-08 at engine coolant temperature sensor for damage.

Q: Is the harness connector in good condition?

YES : Go to Step 6.

NO : Repair or replace it. Refer to GROUP 00E, Harness Connector Inspection [P.00E-2](#). Then go to Step 14.

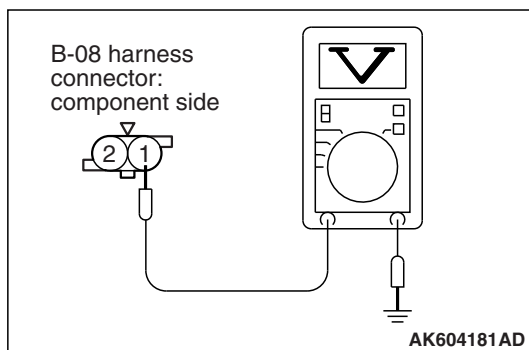

STEP 6. Measure the sensor supply voltage at engine coolant temperature sensor harness side connector B-08.

(1) Disconnect the connector B-08 and measure at the harness side.

(2) Turn the ignition switch to the "ON" position.

(3) Measure the voltage between terminal No. 1 and ground.

- Voltage should be between 4.5 and 4.9 volts.

(4) Turn the ignition switch to the "LOCK" (OFF) position.

Q: Is the measured voltage between 4.5 and 4.9 volts?

YES : Go to Step 8.

NO : Go to Step 7.

STEP 7. Check harness connector B-09 at ECM for damage.

Q: Is the harness connector in good condition?

YES : Replace the ECM. When the ECM is replaced, register the ID code. Refer to GROUP 42B, ID Code Registration Necessity Judgment Table <Vehicles with KOS> [P.42B-11](#) or GROUP 42C, ID Codes Registration Judgment Table <Vehicles with WCM> [P.42C-9](#). Then go to Step 14.

NO : Repair or replace it. Refer to GROUP 00E, Harness Connector Inspection [P.00E-2](#). Then go to Step 14.

STEP 8. Check the continuity at engine coolant temperature sensor harness side connector B-08.

(1) Disconnect the connector B-08 and measure at the harness side.

(2) Check for the continuity between terminal No. 2 and ground.

- Continuity (2 ohms or less)

Q: Does continuity exist?

YES : Go to Step 11.

NO : Go to Step 9.

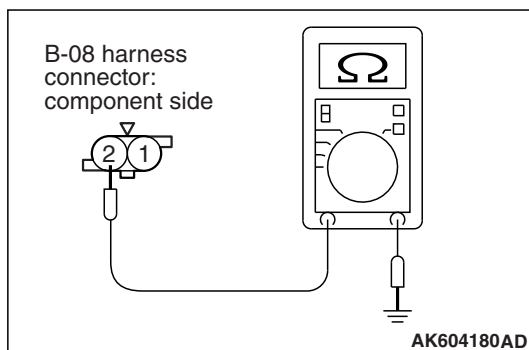

STEP 9. Check harness connector B-09 at ECM for damage.

Q: Is the harness connector in good condition?

YES : Go to Step 10.

NO : Repair or replace it. Refer to GROUP 00E, Harness Connector Inspection [P.00E-2](#). Then go to Step 14.

STEP 10. Check for harness damage between engine coolant temperature sensor connector B-08 (terminal No. 2) and ECM connector B-09 (terminal No. 27).

Q: Is the harness wire in good condition?

YES : Replace the ECM. When the ECM is replaced, register the ID code. Refer to GROUP 42B, ID Code Registration Necessity Judgment Table <Vehicles with KOS> [P.42B-11](#) or GROUP 42C, ID Codes Registration Judgment Table <Vehicles with WCM> [P.42C-9](#). Then go to Step 14.

NO : Repair it. Then go to Step 14.

STEP 11. Check the engine coolant temperature sensor.
Refer to Engine Coolant Temperature Sensor Check [P.13A-875](#).

Q: Is the engine coolant temperature sensor normal?

YES : Go to Step 12.

NO : Replace the engine coolant temperature sensor. Then go to Step 14.

STEP 12. Check harness connector B-09 at ECM for damage.

Q: Is the harness connector in good condition?

YES : Go to Step 13.

NO : Repair or replace it. Refer to GROUP 00E, Harness Connector Inspection [P.00E-2](#). Then go to Step 14.

STEP 13. Check for harness damage between engine coolant temperature sensor connector B-08 (terminal No. 1) and ECM connector B-09 (terminal No. 26).

Q: Is the harness wire in good condition?

YES : Replace the ECM. When the ECM is replaced, register the ID code. Refer to GROUP 42B, ID Code Registration Necessity Judgment Table <Vehicles with KOS> [P.42B-11](#) or GROUP 42C, ID Codes Registration Judgment Table <Vehicles with WCM> [P.42C-9](#). Then go to Step 14.

NO : Repair it. Then go to Step 14.

STEP 14. Test the OBD-II drive cycle.

- (1) Carry out a test drive with the drive cycle pattern. Refer to Diagnostic Function –OBD-II Drive Cycle –Pattern 8 [P.13A-9](#).
- (2) Check the diagnostic trouble code (DTC).

Q: Is DTC P0125 set?

- YES** : Retry the troubleshooting.
NO : The inspection is complete.
-

DTC P0128: Coolant Thermostat (Coolant Temperature Below Thermostat Regulating Temperature)

TECHNICAL DESCRIPTION

- The ECM checks the time for the cooling water temperature to reach the judgement temperature.

DESCRIPTIONS OF MONITOR METHODS

Engine coolant temperature does not reach 77° C (171° F) within specified period after cold start.

MONITOR EXECUTION

Once per driving cycle

**MONITOR EXECUTION CONDITIONS
(Other monitor and Sensor)**

Other Monitor (There is no temporary DTC stored in memory for the item monitored below)

- Vehicle speed signal monitor

Sensor (The sensor below is determined to be normal)

- Mass airflow sensor
- Engine coolant temperature sensor
- Intake air temperature sensor

DTC SET CONDITIONS

Logic Flow Chart

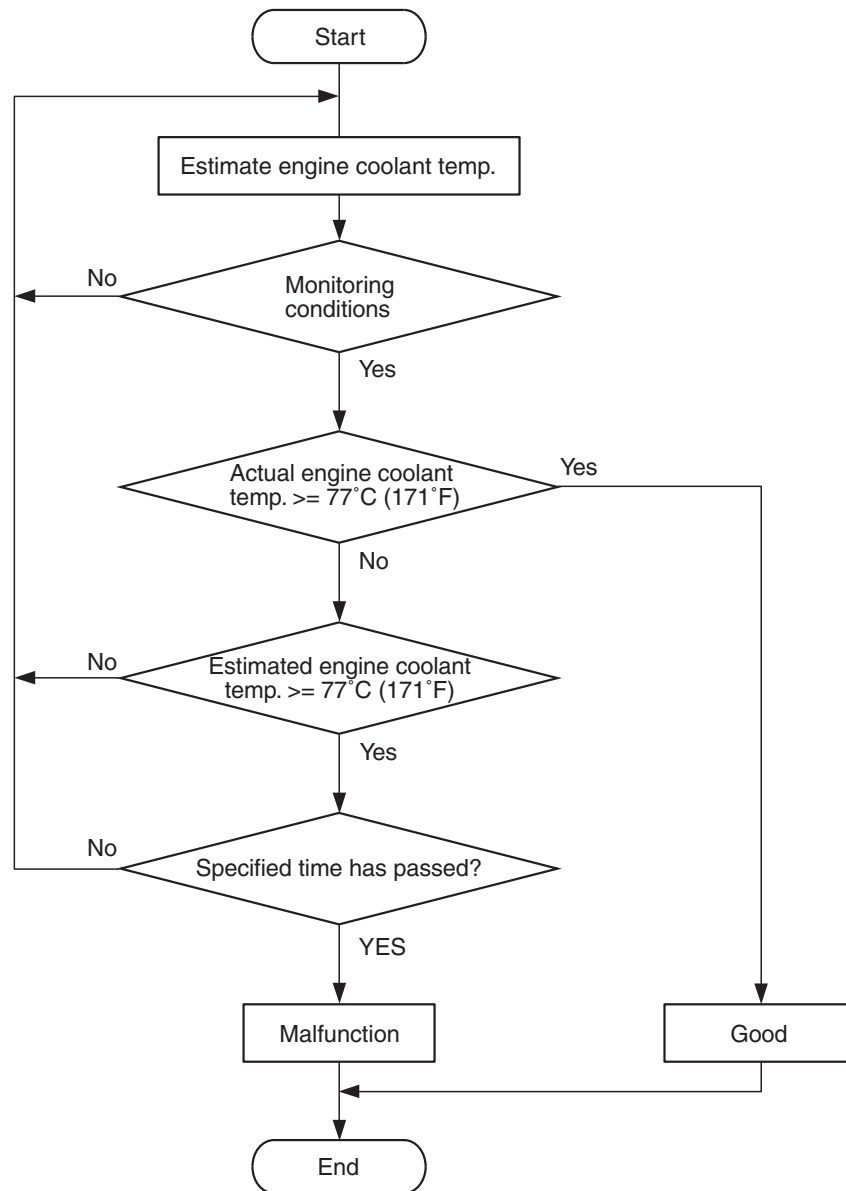

AK900356

Check Conditions

- Engine coolant temperature is between -10°C (14°F) and 60°C (140°F) when the engine is started.
- Intake air temperature is -10°C (14°F) or higher.
- The intake air temperature subtracted from the intake air temperature when the engine is started is lower than 10°C (18°F).
- The total time when the amount of intake air is small is less than the specified time.

Judgement Criterion

- After the estimated engine coolant temperature rises above 77°C (171°F), the actual engine coolant temperature is less than 77°C (171°F) even though the specified time has passed.

FAIL-SAFE AND BACKUP FUNCTION

- None

OBD-II DRIVE CYCLE PATTERN

Refer to Diagnostic Function –OBD-II Drive Cycle – Pattern 9 [P.13A-9](#).

TROUBLESHOOTING HINTS (The most likely causes for this code to be set are:)

- The engine cooling system is faulty.
- ECM failed.

DIAGNOSIS

STEP 1. Check the cooling system.

Refer to GROUP 14, Engine Cooling Diagnosis [P.14-3](#).

Q: Is the cooling system normal?

YES : Replace the ECM. When the ECM is replaced, register the ID code. Refer to GROUP 42B, ID Code Registration Necessity Judgment Table <Vehicles with KOS> [P.42B-11](#) or GROUP 42C, ID Codes Registration Judgment Table <Vehicles with WCM> [P.42C-9](#). Then go to Step 2.

NO : Repair it. Then go to Step 2.

STEP 2. Test the OBD-II drive cycle.

(1) Carry out test drive with the drive cycle pattern. Refer to Diagnostic Function –OBD-II Drive Cycle –Pattern 9 [P.13A-9](#).

(2) Check the diagnostic trouble code (DTC).

Q: Is DTC P0128 set?

YES : Retry the troubleshooting.

NO : The inspection is complete.