

## GROUP 37

## POWER STEERING

## CONTENTS

<b>GENERAL INFORMATION</b> .....	<b>37-3</b>	TIE-ROD LOOSENESS CHECK .....	37-18
<b>SPECIFICATIONS</b> .....	<b>37-4</b>	BALL JOINT DUST COVER CHECK .....	37-23
GENERAL SPECIFICATIONS .....	37-4	TIE ROD END BALL JOINT ROTATION TORQUE CHECK .....	37-23
SERVICE SPECIFICATIONS .....	37-4	STATIONARY STEERING EFFORT CHECK .....	37-24
LUBRICANTS .....	37-5	STEERING WHEEL RETURN TO CENTER CHECK .....	37-24
SEALANT .....	37-5	DRIVE BELT TENSION CHECK .....	37-24
<b>POWER STEERING DIAGNOSIS</b> ...	<b>37-6</b>	FLUID LEVEL CHECK .....	37-25
INTRODUCTION TO POWER STEERING DIAGNOSIS .....	37-6	FLUID REPLACEMENT .....	37-25
POWER STEERING DIAGNOSIS TROUBLESHOOTING STRATEGY .....	37-6	POWER STEERING SYSTEM AIR BLEEDING .....	37-26
SYMPTOM CHART .....	37-6	OIL PUMP PRESSURE TEST .....	37-29
SYMPTOM PROCEDURES .....	37-7	POWER STEERING PRESSURE SWITCH CHECK .....	37-30
<b>SPECIAL TOOLS</b> .....	<b>37-15</b>	STEERING COLUMN SHAFT ASSEMBLY SHOCK ABSORBING MECHANISM CHECK .....	37-31
<b>ON-VEHICLE SERVICE</b> .....	<b>37-17</b>		
STEERING WHEEL FREE PLAY CHECK .	37-17		
STEERING ANGLE CHECK .....	37-18		

Continued on next page

## WARNINGS REGARDING SERVICING OF SUPPLEMENTAL RESTRAINT SYSTEM (SRS) EQUIPPED VEHICLES

 **WARNING**

- *Improper service or maintenance of any component of the SRS, or any SRS-related component, can lead to personal injury or death to service personnel (from inadvertent firing of the air bag) or to the driver and passenger (from rendering the SRS inoperative).*
- *Service or maintenance of any SRS component or SRS-related component must be performed only at an authorized MITSUBISHI dealer.*
- *MITSUBISHI dealer personnel must thoroughly review this manual, and especially its GROUP 52B - Supplemental Restraint System (SRS) before beginning any service or maintenance of any component of the SRS or any SRS-related component.*

## NOTE

The SRS includes the following components: SRS air bag control unit, SRS warning light, front impact sensors, air bag module, side-airbag module, curtain air bag module, side impact sensors, seat belt pre-tensioners, clock spring, and interconnecting wiring. Other SRS-related components (that may have to be removed/installed in connection with SRS service or maintenance) are indicated in the table of contents by an asterisk (\*).

<b>STEERING WHEEL*</b> .....	<b>37-32</b>	<b>POWER STEERING OIL PUMP ASSEMBLY</b> .....	<b>37-48</b>
REMOVAL AND INSTALLATION .....	37-32	REMOVAL AND INSTALLATION .....	37-48
<b>STEERING COLUMN SHAFT ASSEMBLY*</b> .....	<b>37-36</b>	INSPECTION.....	37-50
REMOVAL AND INSTALLATION .....	37-36	DISASSEMBLY AND ASSEMBLY	
DISASSEMBLY AND ASSEMBLY .....	37-39	<2.4L Engine> .....	37-50
<b>POWER STEERING GEAR BOX AND LINKAGE*</b> .....	<b>37-41</b>	INSPECTION.....	37-53
REMOVAL AND INSTALLATION .....	37-41	<b>POWER STEERING HOSES</b> .....	<b>37-54</b>
INSPECTION .....	37-44	REMOVAL AND INSTALLATION .....	37-54
DISASSEMBLY AND ASSEMBLY .....	37-45		

## GENERAL INFORMATION

M1372000101556

- The steering wheel has three spokes. All vehicles are equipped with SRS (Supplemental Restraint System).
- The steering column has a shock absorbing mechanism and a tilt steering mechanism.
- The steering system uses a vane oil pump with a fluid flow control system, so that steering effort varies with engine speed.

### <2.0L Engine>

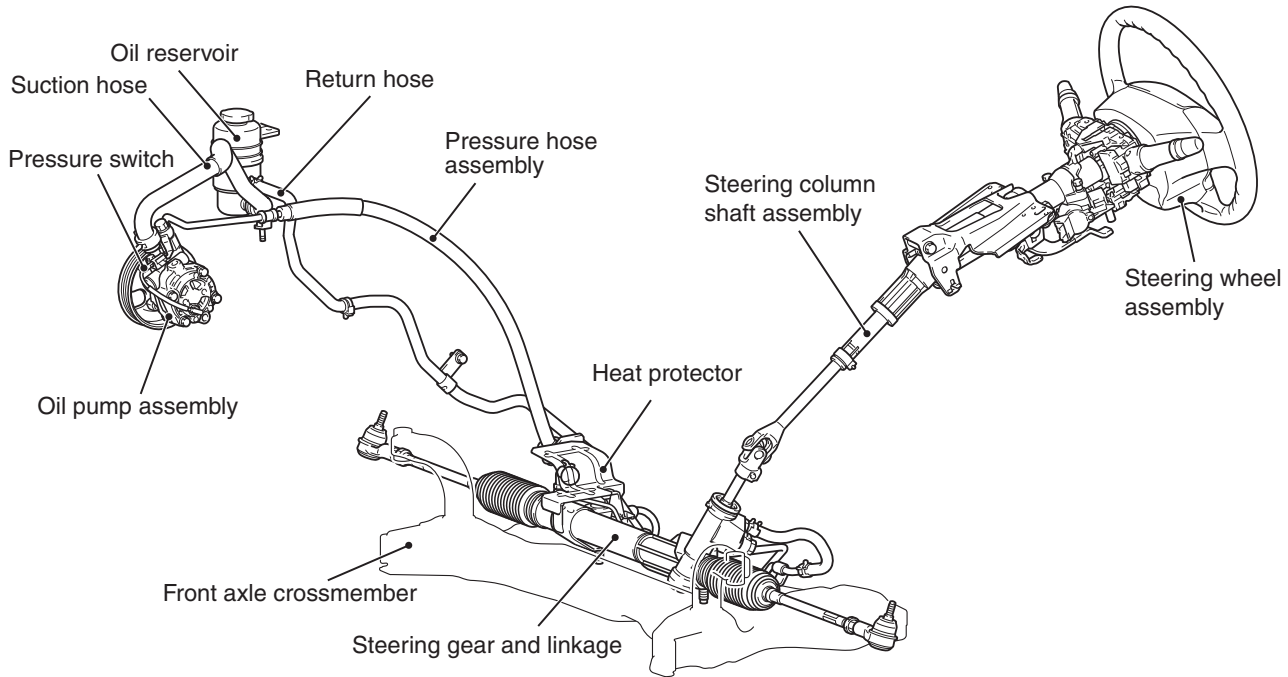

AC802969 AC

### <2.4L Engine>

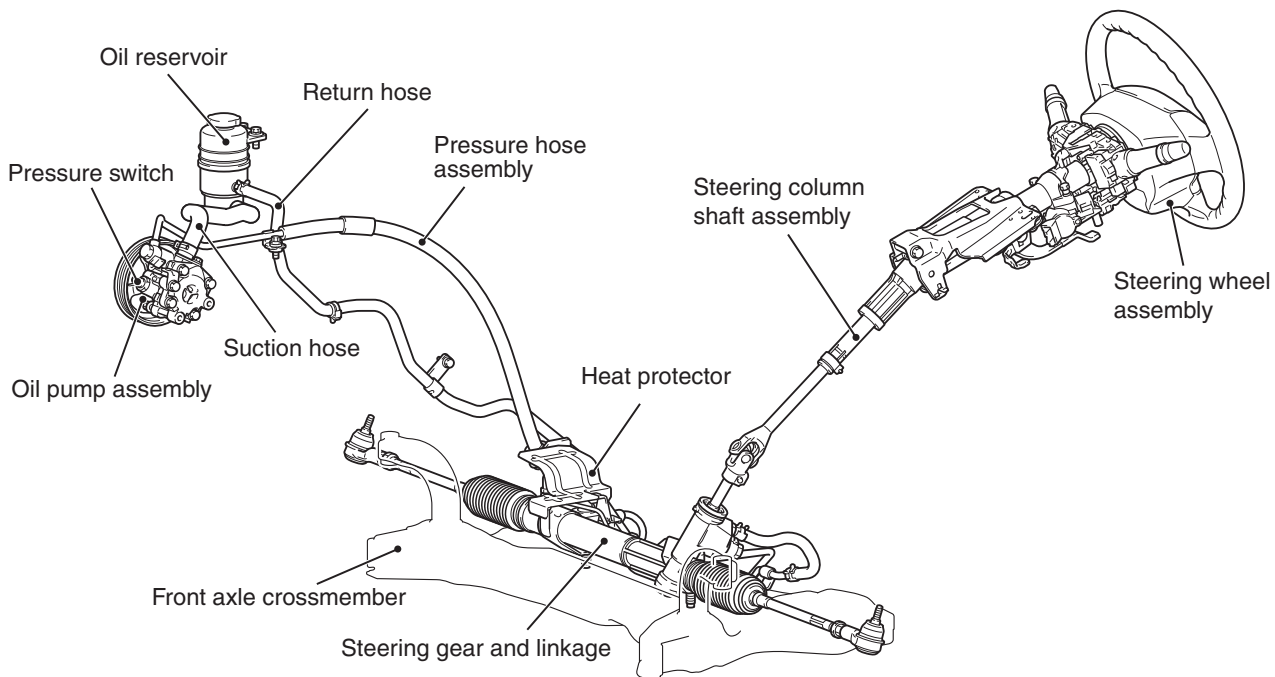

AC607284 AD

## SPECIFICATIONS

## GENERAL SPECIFICATIONS

M1372000200516

Item		2.0L Engine	2.4L Engine
Steering wheel	Type	Three-spoke type	
	Outside diameter mm (in)	365 (14.4)	375 (14.7)
	Maximum number of turns	3.16	3.16
Steering column	Column mechanism	Shock absorbing mechanism and Tilt steering mechanism	
Power steering type		Integral type (Engine speed-dependent type)	
Oil pump	Type	Vane type with fluid flow amount control system	
	Basic discharge amount cm <sup>3</sup> /rev. (cu in/rev)	9.0 (0.55)	8.1 (0.49)
	Reservoir type	Separate type (Resin made)	
Steering gear	Type	Rack and pinion type	
	Stroke ratio (Rack stroke/Steering wheel maximum number of turns) mm/rev (in/rev)	45.58 (1.79)	45.58 (1.79)
	Rack stroke mm (in)	144 (5.7)	144 (5.7)

## SERVICE SPECIFICATIONS

M1372000301970

Item		Standard value	Limit	
Steering wheel free play mm (in)	With engine running	–	30 (1.2) or less	
	With engine stopped	16.5 (0.65) or less	–	
Steering angle	Inner wheel	40° 50' ± 1° 30' (Left/right deviation within 2° 00')	–	
	Outer wheel (reference value)	33° 50'	–	
Toe-in mm (in)		1 ± 2 (0.04 ± 0.08)	–	
Tie rod end ball joint rotation torque N· m (in-lb)		2.9 (26) or less	–	
Engine idle speed r/min		700 ± 50	–	
Stationary steering effort N (lb) [Fluctuation allowance N (lb)]		29 (6.5) or less [5.9 (1.33) or less]	–	
Oil pump pressure MPa (psi)	Oil pump relief pressure	2.0L Engine	8.1 – 8.8 (1,175 – 1,276)	–
		2.4L Engine	8.8 – 9.5 (1,276 – 1,378)	–
	Pressure under no-load conditions	2.0L Engine	1.0 (145)	–
		2.4L Engine	0.2 – 0.7 (29 – 102)	–
	Steering gear retention hydraulic pressure	2.0L Engine	8.1 – 8.8 (1,175 – 1,276)	–
		2.4L Engine	8.8 – 9.5 (1,276 – 1,378)	–

Item			Standard value	Limit
Oil pressure switch operating pressure MPa (psi)	OFF →ON	2.0L Engine	2.5 –3.0 (363 –435)	–
	ON →OFF		1.5 –3.0 (218 –435)	–
	OFF →ON	2.4L Engine	1.5 –2.0 (218 –290)	–
	ON →OFF		0.5 –2.0 (73 –290)	–
Steering gear total pinion torque N· m (in-lb) [Change in torque N· m (in-lb)]			1.0 –2.0 (8.9 –17.7) [0.4 (3.5) or less]	–
Band crimped width mm (in)			2.4 –2.8 (0.09 –0.11)	–

**LUBRICANTS**

M1372000400855

Item		Specified lubricant	Quantity dm <sup>3</sup> (qt)
Power steering fluid		Genuine MITSUBISHI power steering fluid or ATF DEXRON III or DEXRON II	1.0 (1.06)
Steering gear	Bearing	Genuine MITSUBISHI power steering fluid or ATF DEXRON III or DEXRON II	As required
	O-ring and seal ring		
	Oil seal		
	Special tool (MB991213)		
	Pinion and valve assembly seal ring part		
	Bellows	Silicon grease	As required
Oil pump	Friction surface of rotor vane, cam ring and pump cover	Genuine MITSUBISHI power steering fluid or ATF DEXRON III or DEXRON II	As required
	O-ring		

**SEALANT**

M1372000500896

Item		Specified sealant	Quantity dm <sup>3</sup> (qt)
Steering gear	Bellows	3M™ AAD Part No.8663 or equivalent	As required

**POWER STEERING DIAGNOSIS****INTRODUCTION TO POWER STEERING DIAGNOSIS**

M1372008500254

Hydraulic power steering is used for all vehicles. Faults in the power steering can include excessive play of the steering wheel, difficult steering wheel operation, noise, vibration, and oil leaks, etc. Possible causes of these faults can include defects in the gear box, oil pump or steering linkage.

**POWER STEERING DIAGNOSIS TROUBLESHOOTING STRATEGY**

M1372007300291

Use these steps to plan your diagnostic strategy. If you follow them carefully, you will be sure that you have exhausted most of the possible ways to find a power steering fault.

1. Gather information from the customer.

2. Verify that the condition described by the customer exists.

3. Find the malfunction by following the Symptom Chart.

4. Verify malfunction is eliminated.

**SYMPTOM CHART**

M1372007600366

Symptom	Inspection procedure	Reference page
Excessive play of steering wheel	1	<a href="#">P.37-7</a>
Difficult steering wheel operation (insufficient power assist)	2	<a href="#">P.37-8</a>
Rattling noise	3	<a href="#">P.37-10</a>
Shrill noise	4	<a href="#">P.37-10</a>
Squealing noise	5	<a href="#">P.37-10</a>
Hissing noise	6	<a href="#">P.37-11</a>
Droning noise	7	<a href="#">P.37-11</a>
Squeaking noise	8	<a href="#">P.37-12</a>
Vibration	9	<a href="#">P.37-13</a>
Oil leakage from hose connection	10	<a href="#">P.37-13</a>
Oil leakage from hose assembly	11	<a href="#">P.37-13</a>
Oil leakage from oil reservoir	12	<a href="#">P.37-14</a>
Oil leakage from oil pump	13	<a href="#">P.37-14</a>
Oil leakage from steering gear	14	<a href="#">P.37-14</a>

---

## SYMPTOM PROCEDURES

---

### INSPECTION PROCEDURE 1: Excessive Play of Steering Wheel

---

#### DIAGNOSIS

---

**STEP 1. Check for looseness at the steering shaft coupling section and at the steering wheel linkage.**

**Q: Is there any looseness?**

**YES :** Repair or replace the part. Then go to Step 3.

**NO :** Go to Step 2.

---

**STEP 2. Check the steering wheel free play.**

(1) With the engine running (hydraulic operation), set the front wheels straight ahead.

(2) Measure the play on the steering wheel circumference before the wheels start to move when slightly moving the steering wheel in both directions.

**Limit: 30 mm (1.2 inch) or less**

(3) If the free play exceeds the limit value, set the steering wheel straight ahead with the engine stopped. Load approximately 5 N (1.1 pound) towards the steering circumference and check the play.

**Standard value (steering wheel free play with engine stopped): 16.5 mm (0.65 inch) or less**

**Q: Does the play exceed the standard value?**

**YES :** Remove the steering gear box (Refer to [P.37-41](#)) and check the total pinion torque (Refer to [P.37-41](#)). Then go to Step 3.

**NO :** Go to Step 3.

---

**STEP 3. Check the steering wheel play.**

Verify that the steering wheel play is not excessive.

**Q: Is the steering wheel play excessive?**

**YES :** Repeat from Step 1.

**NO :** The procedure is complete.

## INSPECTION PROCEDURE 2: Difficult Steering Wheel Operation (Insufficient Power Assist)

## DIAGNOSIS

**STEP 1. Check the power steering oil pump drive belt tension.**

Refer to GROUP 11A –On-vehicle Service –Drive Belt Tension Check [P.11A-9](#) <2.0L Engine>, GROUP 11C –On-vehicle Service –Drive Belt Tension Check [P.11C-8](#) <2.4L Engine>.

**Q: Is the power steering oil pump drive belt tension within the standard value?**

**YES** : Go to Step 2.

**NO** : Adjust the tension (Refer to GROUP 11A –On-vehicle Service –Drive Belt Tension Check [P.11A-9](#) <2.0L Engine>, GROUP 11C –On-vehicle Service –Drive Belt Tension Check [P.11C-8](#) <2.4L Engine>). Then go to Step 10.

**STEP 2. Check the drive belt for damage.****Q: Is the drive belt damaged?**

**YES** : Replace the drive belt (Refer to GROUP 11A –On-vehicle Service –Drive Belt Tension Check [P.11A-9](#) <2.0L Engine>, GROUP 11C –On-vehicle Service –Drive Belt Tension Check [P.11C-8](#) <2.4L Engine>). Then go to Step 10.

**NO** : Go to Step 3.

**STEP 3. Check the fluid level.**

- (1) Park the vehicle on a flat, level surface, and then start the engine.
- (2) Turn the steering wheel several times to raise the temperature of the fluid to approximately 50 –60° C (122 – 140° F).
- (3) With the engine running, turn the wheel all the way to the left and right several times.
- (4) Check the fluid in the oil reservoir for foaming or milkiness. Check the difference of the fluid level when the engine is stopped, and while it is running. If the change of the fluid level is 5 mm (0.2 inch) or more, bleed the air from the system (Refer to [P.37-26](#)).

**Q: Is the fluid foamy?**

**YES** : Go to Step 4.

**NO** : Go to Step 10.

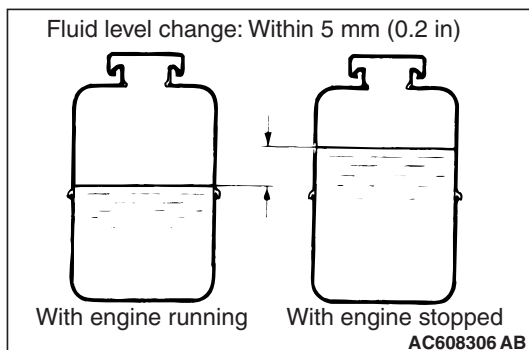
**STEP 4. Check for entry of air.****Q: Has air entered?**

**YES** : Bleed the air (Refer to [P.37-26](#)). Then go to Step 10 .

**NO** : Go to Step 5.



---

**STEP 5. Check each hose for crushing or twisting.**

**Q: Is any hose crushed or twisted?**

**YES :** Repair or replace the hose (Refer to [P.37-54](#)). Then go to Step 10.

**NO :** Go to Step 6.

---

**STEP 6. Check for oil leaks.**

**Q: Are there oil leaks?**

**YES :** Repair it. Then go to Step 10.

**NO :** Go to Step 7.

---

**STEP 7. Check the wheel alignment (camber and caster).**

Refer to GROUP 33, On-vehicle Service –Front Wheel Alignment Check and Adjustment [P.33-8](#).

**Q: Is the alignment incorrect?**

**YES :** Adjust it (Refer to [P.33-8](#)). Then go to Step 10 .

**NO :** Go to Step 8.

---

**STEP 8. Check the gear box rack piston seal for damage.**

**Q: Is there damage?**

**YES :** Replace it (Refer to [P.37-45](#)). Then go to Step 10 .

**NO :** Go to Step 9.

---

**STEP 9. Check for excessive tie rod end ball joint breakaway torque.**

Refer to [P.37-23](#).

**Q: Is there fault?**

**YES :** Replace the part (Refer to [P.37-45](#)). Then go to Step 10 .

**NO :** Go to Step 10.

---

**STEP 10. Check the steering wheel operation.**

Verify that the steering wheel operation is not difficult.

**Q: Is the steering wheel operation difficult?**

**YES :** Repeat from Step 1.

**NO :** The procedure is complete.

**INSPECTION PROCEDURE 3: Rattling Noise****DIAGNOSIS**

**STEP 1. Check for proper oil pump and steering gear installation.**

**Q: Is the oil pump and the steering gear installation correct?**

**YES :** Go to Step 2.

**NO :** Repair it (Refer to [P.37-48](#), [P.37-41](#)). Then go to Step 4.

**STEP 2. Check for interference of other parts with the steering column and the power steering hoses.**

**Q: Is there interference?**

**YES :** Correct the interference. Then go to Step 4.

**NO :** Go to Step 3.

**STEP 3. Check for noise from inside the oil pump or the steering gear.**

**Q: Is there noise?**

**YES :** Replace the part (Refer to [P.37-48](#), [P.37-45](#)). Then go to Step 4.

**NO :** Go to Step 4.

**STEP 4. Check for rattling noise.**

Confirm that no noise is generated.

**Q: Is there noise?**

**YES :** Repeat from Step 1.

**NO :** The procedure is complete.

**INSPECTION PROCEDURE 4: Shrill Noise****DIAGNOSIS**

**STEP 1. Check for entry of air.**

**Q: Is the power steering fluid foamy?**

**YES :** Bleed the air (Refer to [P.37-26](#)). Then go to Step 3.

**NO :** Go to Step 2.

**STEP 2. Check for seizure in the oil pump.**

**Q: Is there seizure?**

**YES :** Replace the part (Refer to [P.37-48](#)). Then go to Step 3 .

**NO :** Go to Step 3.

**STEP 3. Retest the system.**

Confirm that no noise is generated.

**Q: Is there noise?**

**YES :** Repeat from Step 1.

**NO :** The procedure is complete.

**INSPECTION PROCEDURE 5: Squealing Noise****DIAGNOSIS**

**STEP 1. Check the drive belt tension.**

Refer to GROUP 11A –On-vehicle service –Drive belt tension check [P.11A-9](#) <2.0L Engine>, GROUP 11C –On-vehicle service –Drive belt tension check [P.11C-8](#) <2.4L Engine>.

**Q: Is the drive belt tension incorrect?**

**YES :** Adjust the belt tension (Refer to GROUP 11A –On-vehicle Service –Drive Belt Tension Check [P.11A-9](#) <2.0L Engine>, GROUP 11C –On-vehicle Service –Drive

Belt Tension Check [P.11C-8](#) <2.4L Engine>). Then go to Step 3.

**NO :** Go to Step 2.

**STEP 2. Check for seizure in the oil pump.**

**Q: Is there seizure?**

**YES :** Replace the part (Refer to [P.37-48](#)). Then go to Step 3 .

**NO :** Go to Step 3.

---

**STEP 3. Retest the system.**

Confirm that no noise is generated.

**Q: Is there noise?**

**YES :** Repeat from Step 1.

**NO :** The procedure is complete.

---

**INSPECTION PROCEDURE 6: Hissing Noise**

---

**DIAGNOSIS**

---

**STEP 1. Check for entry of air.**

**Q: Is the power steering fluid foamy?**

**YES :** Bleed the air (Refer to [P.37-26](#)). Then go to Step 4.

**NO :** Go to Step 2.

---

**STEP 2. Check each hose for crushing or twisting.**

**Q: Is any hose crushed or twisted?**

**YES :** Replace the hose (Refer to [P.37-54](#)). Then go to Step 4 .

**NO :** Go to Step 3.

---

**STEP 3. Check the steering gear for damage.**

**Q: Is there damage?**

**YES :** Replace the part (Refer to [P.37-45](#)). Then go to Step 4 .

**NO :** Go to Step 4.

---

**STEP 4. Retest the system.**

Confirm that no noise is generated.

**Q: Is there noise?**

**YES :** Repeat from Step 1.

**NO :** The procedure is complete.

---

**INSPECTION PROCEDURE 7: Droning Noise**

---

**DIAGNOSIS**

---

**STEP 1. Check the oil pump or oil pump bracket installation.**

**Q: Is the oil pump or the oil pump bracket installation correct?**

**YES :** Go to Step 2.

**NO :** Repair it (Refer to [P.37-48](#), [P.37-41](#)). Then go to Step 3.

**Q: Is there damage?**

**YES :** Replace the oil pump (Refer to [P.37-48](#)). Then go to Step 3 .

**NO :** Go to Step 3.

---

**STEP 3. Retest the system.**

Confirm that no noise is generated.

**Q: Is there noise?**

**YES :** Repeat from Step 1.

**NO :** The procedure is complete.

---

**STEP 2. Check the oil pump for damage.**

*NOTE: If a slight "beat noise" is produced by the oil pump when the steering wheel is turned fully and held in that position, this is not a malfunction.*

## INSPECTION PROCEDURE 8: Squeaking Noise

## DIAGNOSIS

**STEP 1. Check for interference of the wheel and the vehicle body.**

If interfering, adjust the steering angle.

- (1) Place the front wheel on a turning radius gauge and measure the steering angle.

**Standard value:**

Inner wheel	40° 50' ± 1° 30' (Left/right deviation within 2° 00')
Outer wheel (reference value)	33° 50'

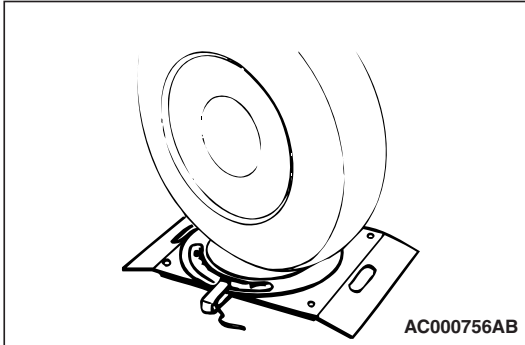

- (2) If the steering angle is not within the standard value, adjust the toe-in.

**Standard value: 1 ± 2 mm (0.04 ± 0.08 inch)**

- (3) Adjust the toe-in by undoing the clip and jam nut, and turning the left and right tie rod turnbuckles by the same amount (in opposite directions).

*NOTE: The toe will move out as the left turnbuckle is turned toward the front of the vehicle and the right turnbuckle is turned toward the rear of the vehicle.*

**Q: Is the steering angle normal?**

**YES :** Go to Step 2.

**NO :** Adjust the steering angle (Refer to [P.37-18](#)). Then go to Step 3.

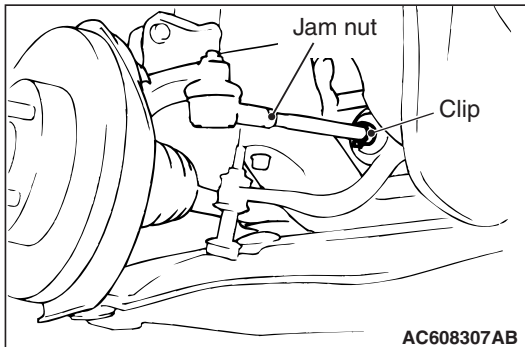
**STEP 2. Check the steering gear for damage.****Q: Is there damage?**

**YES :** Repair or replace the part (Refer to [P.37-45](#)). Then go to Step 3.

**NO :** Go to Step 3.

**STEP 3. Retest the system.**

Confirm that no noise is generated.

**Q: Is there noise?**

**YES :** Repeat from Step 1.

**NO :** The procedure is complete.

---

### INSPECTION PROCEDURE 9: Vibration

---

*NOTE: A slight vibration may be felt when the stationary steering effort is made due to the condition of the road surface. To check whether the vibration actually exists or not, test-drive the vehicle on a dry concrete or asphalt surface. A very slight amount of vibration is not a malfunction.*

#### DIAGNOSIS

---

##### STEP 1. Check for entry of air.

**Q: Is the power steering fluid foamy?**

**YES :** Bleed the air (Refer to [P.37-26](#)). Then go to Step 3.

**NO :** Go to Step 2.

---

##### STEP 2. Check the steering gear for damage.

**Q: Is there damage?**

**YES :** Replace the part (Refer to [P.37-45](#)). Then go to Step 3 .

**NO :** Go to Step 3.

---

##### STEP 3. Retest the system.

Confirm that no vibration is generated.

**Q: Is there vibration?**

**YES :** Repeat from Step 1.

**NO :** The procedure is complete.

---

### INSPECTION PROCEDURE 10: Oil Leakage from Hose Connection

---

#### DIAGNOSIS

---

##### STEP 1. Check for loosening of the return tube flare nut.

**Q: Is the flare nut loose?**

**YES :** Tighten it to standard value (Refer to [P.37-54](#)). Then go to Step 3.

**NO :** Go to Step 2.

---

##### STEP 2. Check the hose connection and the clamp installation.

**Q: Are they correct?**

**YES :** Go to Step 3.

**NO :** Repair or replace the part (Refer to [P.37-54](#)). Then go to Step 3.

---

##### STEP 3. Retest the system.

Check that no oil is leaking.

**Q: Is there oil leakage?**

**YES :** Repeat from Step 1.

**NO :** The procedure is complete.

---

### INSPECTION PROCEDURE 11: Oil Leakage from Hose Assembly

---

#### DIAGNOSIS

---

##### STEP 1. Check the hose for damage or clogging.

**Q: Is the hose damaged or clogged?**

**YES :** Replace it (Refer to [P.37-54](#)). Then go to Step 2.

**NO :** Go to Step 2.

---

##### STEP 2. Retest the system.

Check that no oil is leaking.

**Q: Is there oil leakage?**

**YES :** Repeat from Step 1.

**NO :** The procedure is complete.

**INSPECTION PROCEDURE 12: Oil Leakage from Oil Reservoir****DIAGNOSIS****STEP 1. Check the oil reservoir for damage.****Q: Is there damage?****YES :** Replace the oil reservoir (Refer to [P.37-54](#)).

Then go to Step 3.

**NO :** Go to Step 2.**STEP 2. Check for overflowing.****Q: Is there oil overflowing from the reservoir?****YES :** Adjust fluid level. Then go to Step 3.**NO :** Go to Step 3.**STEP 3. Retest the system.****Q: Is there oil leakage?****YES :** Repeat from to Step 1.**NO :** The procedure is complete.**INSPECTION PROCEDURE 13: Oil Leakage from Oil Pump****DIAGNOSIS****STEP 1. Check the oil pump body for damage.****Q: Is there damage?****YES :** Replace the part (Refer to [P.37-48](#)). Then go to Step 3 .**NO :** Go to Step 2.**STEP 2. Check the O-ring or oil seal for damage.****Q: Is there damage?****YES :** Replace the part (Refer to [P.37-48](#)). Then go to Step 3 .**NO :** Go to Step 3.**STEP 3. Retest the system.**

Check that no oil is leaking.

**Q: Is there oil leakage?****YES :** Repeat from Step 1.**NO :** The procedure is complete.**INSPECTION PROCEDURE 14: Oil Leakage from Steering Gear****DIAGNOSIS****STEP 1. Check the steering gear housing for damage.****Q: Is there damage?****YES :** Replace the part (Refer to [P.37-45](#)). Then go to Step 3 .**NO :** Go to Step 2.**STEP 2. Check the oil-ring or oil seal for damage.****Q: Is there damage?****YES :** Replace the part (Refer to [P.37-45](#)). Then go to Step 3 .**NO :** Go to Step 3.**STEP 3. Retest the system.**

Check that no oil is leaking.

**Q: Is there oil leakage?****YES :** Repeat from Step 1.**NO :** The procedure is complete.

**SPECIAL TOOLS**

M1372000601409

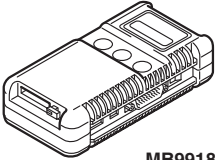
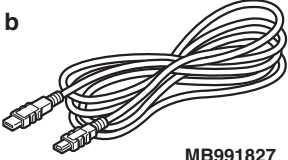
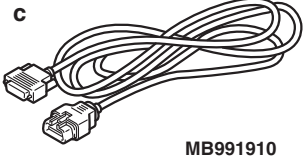
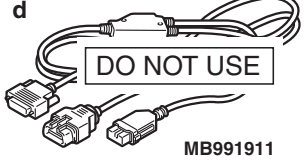
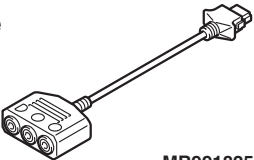
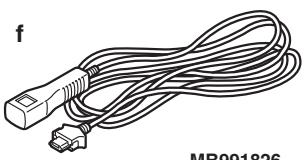
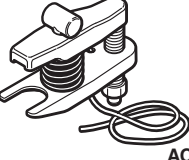
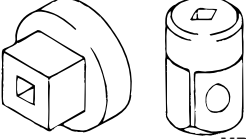
Tool	Tool number and name	Supersession	Application
<p>a</p>  <p>MB991824</p> <p>b</p>  <p>MB991827</p> <p>c</p>  <p>MB991910</p> <p>d</p>  <p>MB991911</p> <p>e</p>  <p>MB991825</p> <p>f</p>  <p>MB991826</p> <p>MB991955</p>	<p>MB991955</p> <p>a: MB991824 b: MB991827 c: MB991910 d: MB991911 e: MB991825 f: MB991826</p> <p>M.U.T.-III Sub Assembly</p> <p>a: Vehicle communication interface (V.C.I.)</p> <p>b: M.U.T.-III USB cable</p> <p>c: M.U.T.-III main harness A (Vehicles with CAN communication system)</p> <p>d: M.U.T.-III main harness B (Vehicles without CAN communication system)</p> <p>e: M.U.T.-III main harness C (for Daimler models only)</p> <p>f: M.U.T.-III trigger Harness</p>	<p>MB991824-KIT</p> <p><i>NOTE: G: MB991826 M.U.T.-III Trigger Harness is not necessary when pushing V.C.I. ENTER key.</i></p>	<p><b>CAUTION</b></p> <p><b>For vehicles with CAN communication, use M.U.T.-III main harness A to send simulated vehicle speed. If you connect M.U.T.-III main harness B instead, the CAN communication does not function correctly.</b></p> <p>Power steering system air bleeding (Calibration by using the scan tool)</p>
 <p>AC106827</p>	<p>MB991897 or MB992011</p> <p>Ball joint remover</p>	<p>MB991113-01, MB990635-01 or</p> <p>General service tool</p>	<p>Knuckle and tie rod end ball joint disconnection</p> <p><i>NOTE: Steering linkage puller (MB990635 or MB991113) is also available to disconnect knuckle and tie rod end ball joint.</i></p>
 <p>MB990326</p>	<p>MB990326</p> <p>Preload socket</p>	<p>General service tool</p>	<p>Tie rod end ball joint breakaway torque check</p>

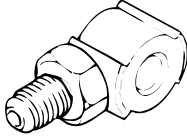
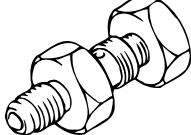
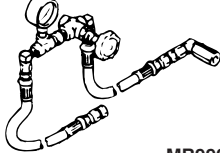
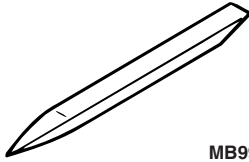
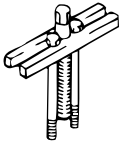
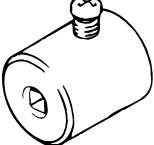
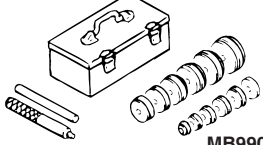
Tool	Tool number and name	Supersession	Application
 <p>MB991548</p>	MB991548 Power steering oil pressure gauge adapter (Pump side)	MB991548-01	Oil pump pressure test
 <p>MB991549</p>	MB991549 Power steering oil pressure gauge adapter (Hose side)	MB991549-01	
 <p>MB990662</p>	MB990662 Power steering oil pressure gauge	MB990662-01	
 <p>MB990784</p>	MB990784 Ornament remover	General service tool	Cover removal
 <p>MB990803</p>	MB990803 Steering wheel puller	General service tool	Steering wheel removal
 <p>MB991006</p>	MB990228 or MB991006 Preload socket	MB990228-01	Steering gear total pinion torque check
 <p>MB990925</p>	MB990925 Bearing and oil seal installer set	MB990925-01 or general service tool	<ul style="list-style-type: none"> <li>• Oil seal and bearing installation</li> <li>• MB990927, MB990938, MB990939 (For details, refer to GROUP 26 – Special Tools P.26-7).</li> </ul>

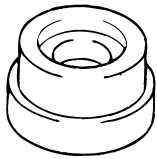
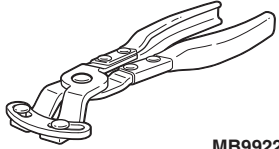
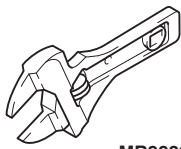

Tool	Tool number and name	Supersession	Application
 MB991203	MB991203 Oil seal and bearing installer	Tool not available	Oil seal and bearing installation
 MB992209	MB992209 Bellows band crimping tool	MB992209	Bellows band installation
 MB992249	MB992249	Variable spanner	Tie-rod removal and installation

## ON-VEHICLE SERVICE

### STEERING WHEEL FREE PLAY CHECK

M1372001000946

1. With the engine running (hydraulic pressure applied), position the front wheel in the straight ahead position.
2. Measure the side to side steering wheel play until the front wheels actually start moving while turning the steering wheel slightly in the left and right directions.

**Limit: 30 mm (1.2 inch) or less**

3. If the steering wheel free play exceeds the limit value, check the steering shaft joint or steering linkage for looseness, and replace or repair the faulty components if necessary.
4. If the steering wheel free play still exceeds the limit value after Step 3 is performed, position the steering wheel in the straight ahead position, and then apply the force (approximately 5 N) in the circumferential direction.

**Standard value (steering wheel free play with the engine stopped): 16.5 mm (0.65 inch) or less**

5. If the steering wheel free play is outside the standard value after Step 4 is performed, remove the steering gear and linkage (Refer to P.37-41), and check and adjust the pinion total rotation torque (Refer to P.37-44).

## STEERING ANGLE CHECK

M1372001101377

**⚠ CAUTION**

After adjusting the steering angle, always perform calibration to make ABS/ASC-ECU learn the neutral position of the steering wheel sensor. (Refer to GROUP 35C –On-vehicle Service –Steering Wheel Sensor Calibration

**P.35C-304).** <Vehicles with ASC>

1. Check that the wheel alignment is normal. (Refer to GROUP 33 –On-vehicle Service, Front Wheel Alignment Check and Adjustment P.33-8.)
2. Place the front wheel on a turning radius gauge and measure the steering angle.

**Standard value:**

Inner wheel	40° 50' ± 1° 30' (Left/right deviation within 2° 00')
Outer wheel (reference value)	33° 50'

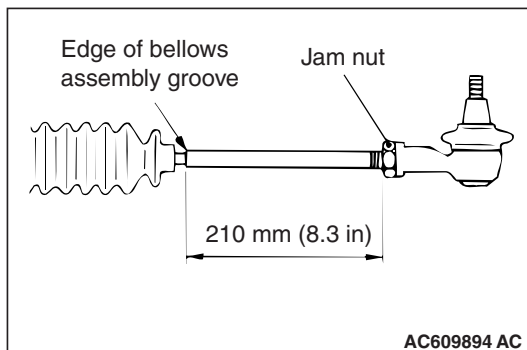
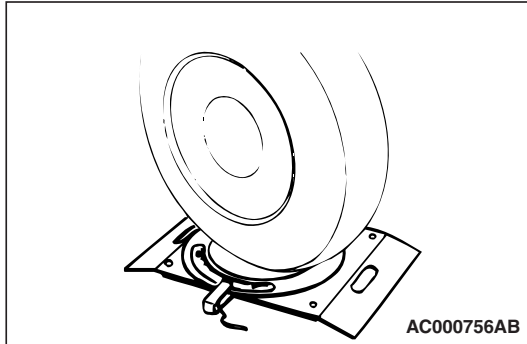

3. If not within the standard value, adjust the tie-rods (right and left), and repeat Steps 1 and 2.
4. If the measured value exceeds the standard range by performing Step 3, replace the steering gear and linkage assembly. (Refer to P.37-41.)

## TIE-ROD LOOSENESS CHECK

M1372018200209

When an abnormal noise is generated by the steering system, check the tie-rod for looseness. For the tie-rod looseness check, using a push-pull gauge and a spring scale, carry out the items below.

- Install a dial gauge.
- Check the points to load for a push-pull gauge and a spring scale.
- Operate to stabilize the load and fluctuation with a push-pull gauge and a spring scale.
- Carry out the dial gauge measurement and calculation with a push-pull gauge and a spring scale.

**When the push-pull gauge is used**

1. Before the looseness check, check the items below.
  - (1) Check that the Mitsubishi genuine wheel with specified size is mounted. Also check that the wheel bearing is not loose. (Refer to GROUP 26 –On-vehicle Service –Wheel Bearing Check for Looseness in the Axial Direction P.26-10.)

- (2) Raise the vehicle at the jack up point on the side sill of the inspection side, and lift the tyre for approximately 30 mm. At this time, check that the tyre of the opposite side is grounded.

2. Install a dial-gauge respectively to the "Position a (front side position)" and "Position b (rear side position)" on the wheel rim, 25 mm below from the wheel centre. (Install the dial gauges to the smooth position that is around the edge of the tyre.)

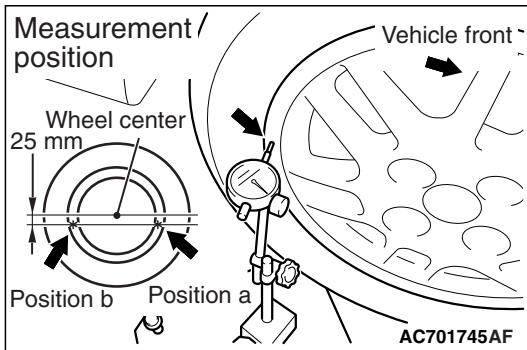

3. The push-pull gauge shall be set to the smooth position that is 25 mm above from the wheel centre and the edge of the tyre on the wheel rim. Then the position on the vehicle front side shall be the "Position A" and the vehicle rear side shall be the "Position B".

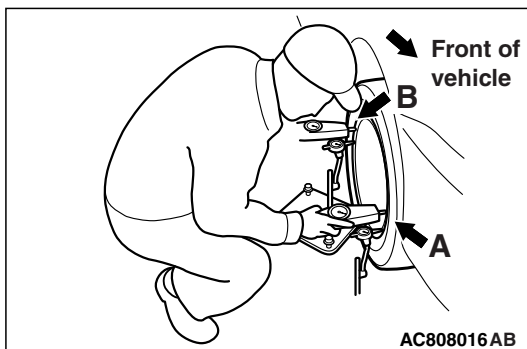

**Point of load**

- Smooth position around the edge of the tyre on the wheel rim

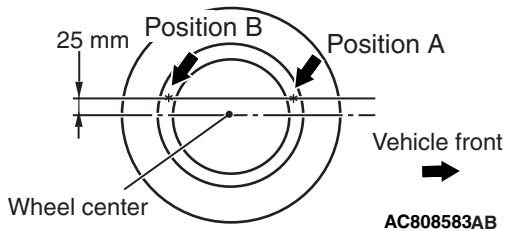

4. To stabilize the relationship between the load and fluctuation, push with the specified load by 100N of "Position A", "Position B", and "Position A" using the push-pull gauge. Note that the pushed load on each position shall be extracted.

5. Using the push-pull gauge, carry out the procedure below to read the value on the dial gauge and calculate the looseness.

*NOTE: The +/- sign acquired with the calculation result shall be used as it is.*

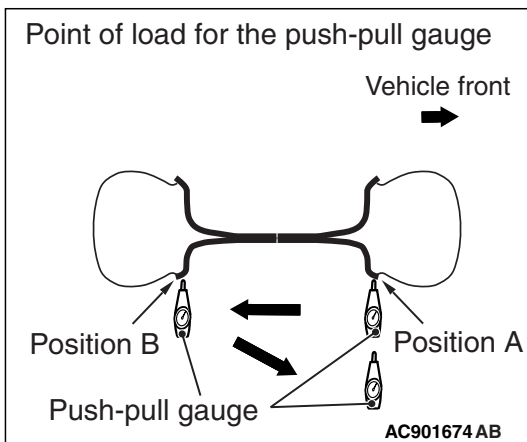

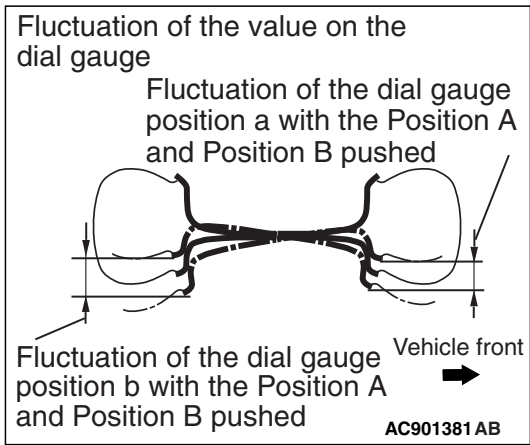
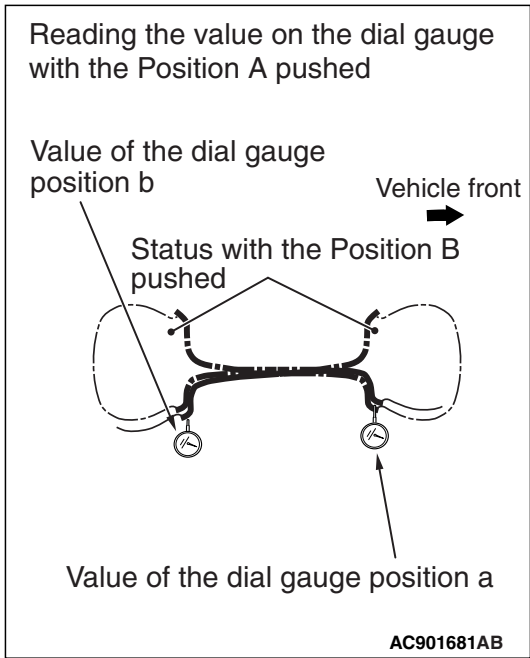
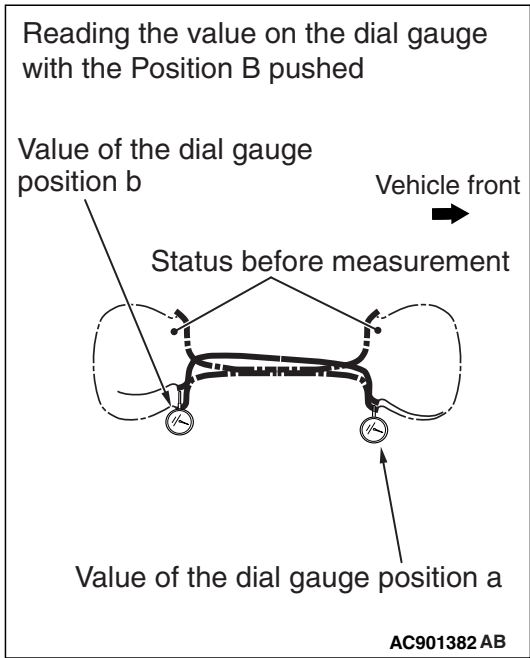

(1) While pushing the "Position B" with the specified load by 100N, read the values on the dial gauges at the "Position a" and "Position b". The values of the dial gauges at this time shall respectively be "aB" and "bB".

(2) Remove the load in the "Position B". Then while pushing the "Position A" with the specified load by 100N, read the values on the dial gauge in the "Position a" and "Position b". The values on the dial gauges at this time shall respectively be "aA" and "bA".

(3) Make calculation taking the value differences of the dial gauge positions a and b which were read while pushing the "Position A" and "Position B" as each fluctuation.

- Fluctuation of the dial gauge position a:  $aA - aB$
- Fluctuation of the dial gauge position b:  $bA - bB$

(4) Calculate each fluctuation difference of the dial gauge positions a and b acquired above for looseness. Perform the procedure above twice.

Fluctuation of the dial gauge position a – Fluctuation of the dial gauge position b

(5) Calculate the average of the looseness calculated twice.

6. If the average exceeds the standard value, check the tie rod end ball joint rotation torque. (Refer to P.37-23.)

**Standard value: Within  $\pm 2.0$  mm**

*NOTE: Measure the tie-rod looseness on the right side and left side respectively.*

**When a spring scale is used**

1. Carry out the confirmation before the looseness check with the same manner as the check using a push-pull gauge.
2. At the position that is 25 mm above from the wheel centre, bind the tyre and the wheel rim with a cord for both the front and rear sides, and fix them with a tape not to loose vertically.
3. Set the spring scale to the cord bound as above. At this time, the point to pull shall be in the dimension between the "Position C" and "Position D" by 525mm, and the position on the vehicle front side shall be the "Position C" and the vehicle rear side shall be the "Position D".

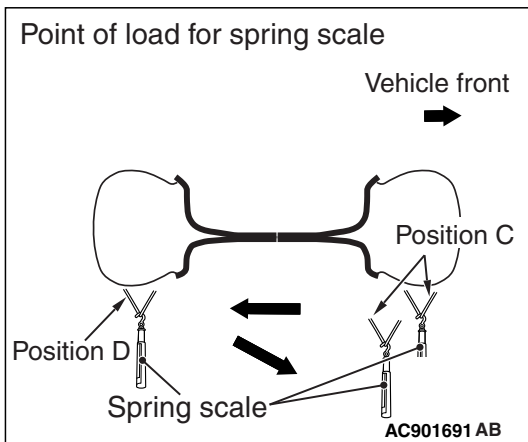
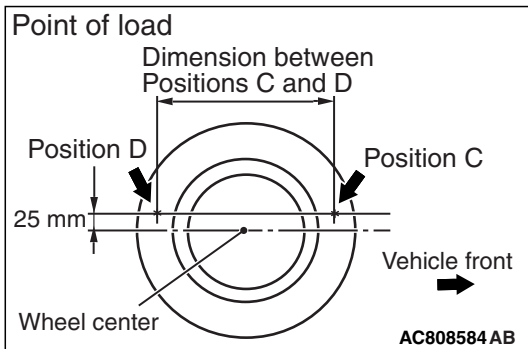
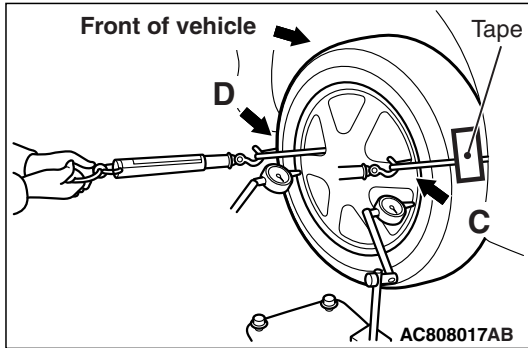

4. To stabilize the relationship between the load and fluctuation, pull with the specified load by 80N of "Position C", "Position D", and "Position C" using the spring scale. Note that the pulled load on each position shall be extracted.
5. Using the spring scale, carry out the procedure below to read the value on the dial gauge and calculate the looseness.

*NOTE: The +/- sign acquired with the calculation result shall be used as it is.*

Reading the value on the dial gauge with the Position D pulled

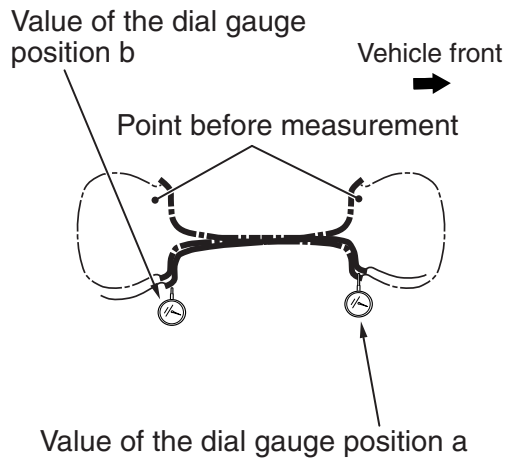

AC901681AC

Reading the value on the dial gauge with the Position C pulled

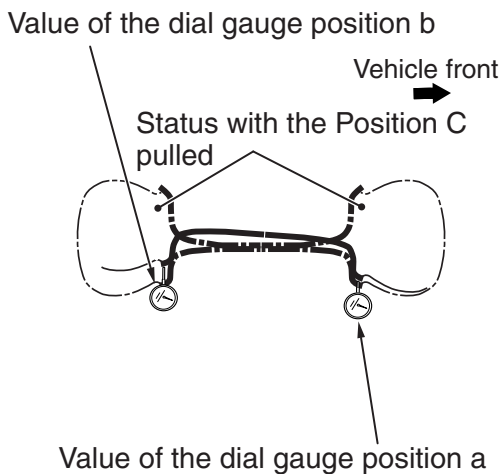

AC901382AC

Fluctuation of the value on the dial gauge

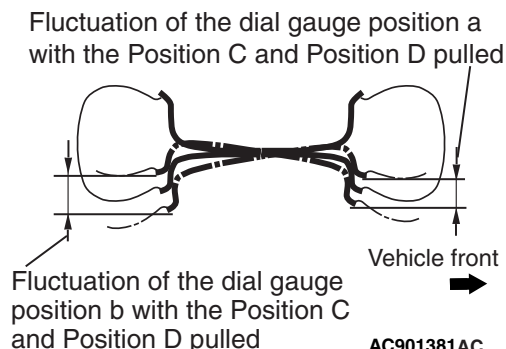

AC901381AC

(1) While pulling the "Position D" with the specified load by 80N, read the values on the dial gauges in the "Position a" and "Position b". The values on the dial gauges at this time shall respectively be "aD" and "bD".

(2) Remove the load at the "Position D". Then while pulling the "Position C" with the specified load by 80N, read the values on the dial gauge in the "Position a" and "Position b". The values on the dial gauges at this time shall respectively be "aC" and "bC".

(3) Make calculation taking the value differences of the dial gauge positions a and b which were read while pulling the "Position C" and "Position D" as each fluctuation.

- Fluctuation of the dial gauge position a:  $aC - aD$
- Fluctuation of the dial gauge position b:  $bC - bD$

(4) Calculate each fluctuation difference of the dial gauge positions a and b acquired above for looseness. Perform the procedure above twice.

Fluctuation of the dial gauge position a – Fluctuation of the dial gauge position b

(5) Calculate the average of the looseness calculated twice.

6. If the average exceeds the standard value, check the tie rod end ball joint rotation torque. (Refer to P.37-23.)

**Standard value: Within  $\pm 2.0$  mm**

*NOTE: Measure the tie-rod looseness on the right side and left side respectively.*

### BALL JOINT DUST COVER CHECK

M1372008600778

1. Using your fingers, press the dust cover to check for cracks or damage.
2. If there are any cracks in the dust cover or it is damaged, replace the tie-rod end (Refer to P.37-45).

*NOTE: If the dust cover has a crack or damage, the ball joint could be damaged.*

### TIE ROD END BALL JOINT ROTATION TORQUE CHECK

M1372001500888

#### Required Special Tools:

- MB990326: Preload Socket
- MB991897 or MB992011: Ball Joint Remover

#### **CAUTION**

- **Loosen the jam nut (tie-rod end connection) from the ball joint, but do not remove here. Use the special tool.**
- **To prevent the special tool from dropping off, suspend it with a cord.**

1. Install special tool MB991897 or MB992011 as shown in the figure.

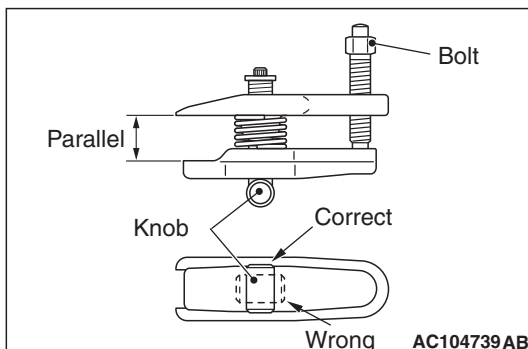
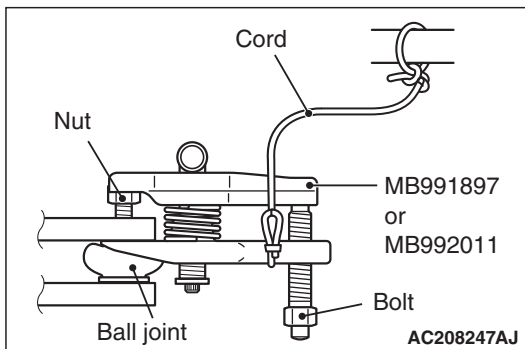

2. Turn the bolt and knob to make the special tool jaws parallel, then hand-tighten the bolt. After tightening, check that the jaws are still parallel.

*NOTE: To adjust the special tool jaws to be parallel, set the orientation of the knob as shown in the figure.*

3. Unscrew the bolt to disconnect the ball joint.

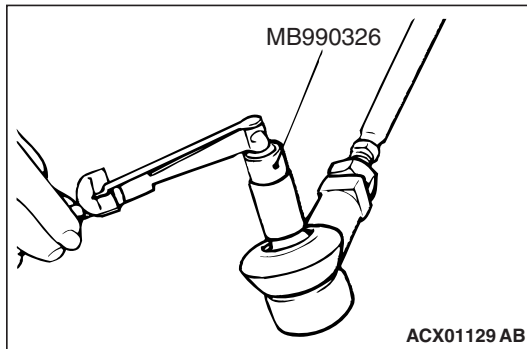

4. Move the ball joint stud several times and install the nut on the stud. Using the special tool MB990326, measure the ball joint rotation torque.

**Standard value: 2.9 N·m (26 in-lb) or less**

5. If the rotation torque exceeds the standard value, replace the tie rod end (Refer to P.37-45).
6. If any looseness or scraping feeling is experienced in the ball joint, even when the measurement is within the range of the standard value, the ball joint should be judged to be faulty. In this case, replace the tie-rod end (Refer to P.37-45).

### STATIONARY STEERING EFFORT CHECK

M1372001700990

1. Park the vehicle on a level paved road, position the steering wheel in the straight ahead position.
2. Start the engine, and maintain the engine speed at 1,000 ± 100 r/min.
3. Position the spring scale on the circumference of the steering wheel, and measure the steering force at the time when the steering wheel is turned to right or left side (within the range of one and a half turns) from the center position.

**Standard value:**

Steering force	29 (6.5 lb) N or less
Fluctuation band	5.9 (1.33 lb) N or less

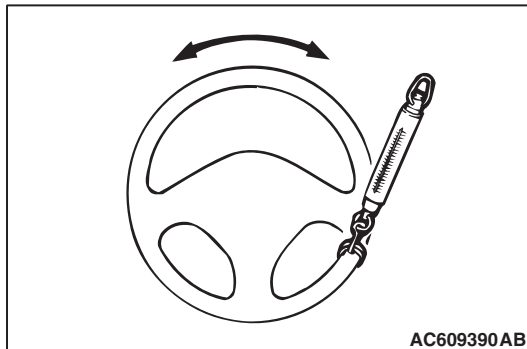

4. If not within the standard value, check and adjust the suspected components.

### STEERING WHEEL RETURN TO CENTER CHECK

M1372001800793

Conduct a road test:

1. Make both gradual and sudden turns and check the steering wheel return.
2. At a vehicle speed of approximately 22 mph (35 km/h), turn the steering wheel 90 degrees, hold a few seconds, then release. If the steering wheel then returns 70 degrees or more, the return can be judged satisfactory.

*NOTE: There will be a momentary feeling or "heaviness" when the wheel is turned quickly, but this is not abnormal (Oil pump discharge amount is especially apt to be insufficient during idling).*

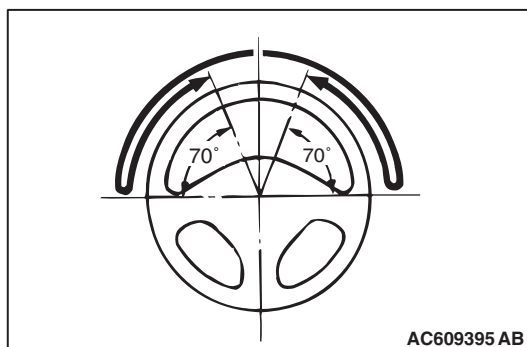

### DRIVE BELT TENSION CHECK

M1372001901243

Refer to GROUP 11A –On-vehicle Service –Drive Belt Tension Check P.11A-9 <2.0L Engine>, Refer to GROUP 11C – On-vehicle Service –Drive Belt Tension Check P.11C-8 <2.4L Engine>.



## FLUID LEVEL CHECK

M1372002000648

1. Park the vehicle on a flat, level surface.
2. Start the engine, and then turn the steering wheel several times to raise the temperature of the fluid to approximately 50 –60° C (122 –140° F).
3. With the engine running, turn the wheel all the way to the left and right several times.
4. Check the fluid in the oil reservoir for foaming or milkiness. Check the difference of the fluid level when the engine is stopped, and while it is running. If the change of the fluid level is 5 mm (0.2 inch) or more, air bleeding should be done (Refer to P.37-26).

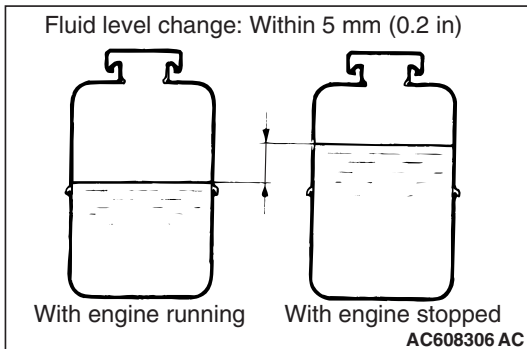

## FLUID REPLACEMENT

M1372002101369

### <2.0L Engine>

1. Raise and support the front wheels.
2. Disconnect the return hose connection, and then connect a vinyl hose to the return hose, and drain the fluid into a container.

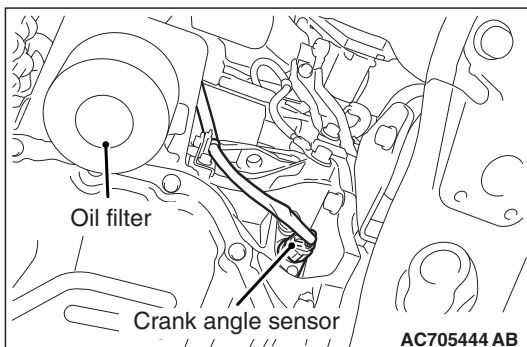
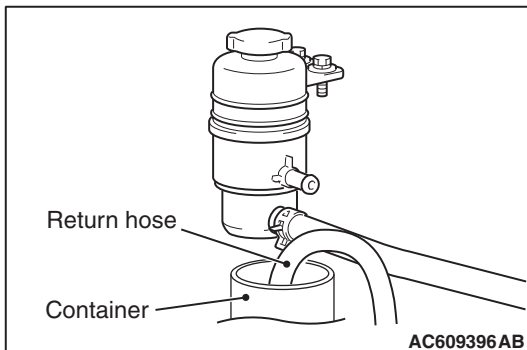

3. Disconnect the crank angle sensor connector.
4. While operating the starter motor intermittently, turn the steering wheel all the way to the left and right several times to drain all of the fluid.
5. Connect the return hose securely, and then secure with the clip.
6. Fill the oil reservoir with GENUINE MITSUBISHI POWER STEERING FLUID to the lower position of the filler, and then bleed the air (Refer to P.37-26).

## &lt;2.4L Engine&gt;

1. Raise and support the front wheels.
2. Disconnect the return hose connection, and then connect a vinyl hose to the return hose, and drain the fluid into a container.

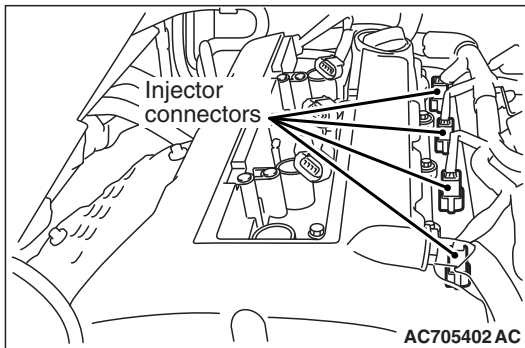
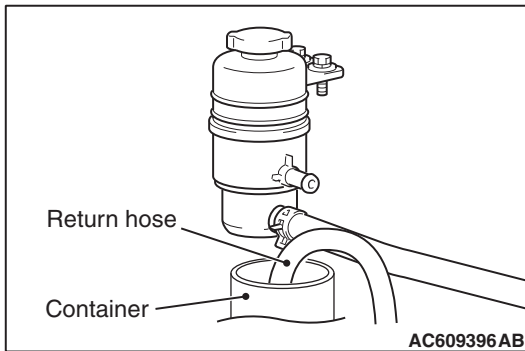

3. Disconnect the all of the injector connectors.
4. While operating the starter motor intermittently, turn the steering wheel all the way to the left and right several times to drain all of the fluid.
5. Connect the return hose securely, and then secure with the clip.
6. Fill the oil reservoir with GENUINE MITSUBISHI POWER STEERING FLUID to the lower position of the filler, and then bleed the air (Refer to P.37-26).

## POWER STEERING SYSTEM AIR BLEEDING

M1372002201366

Perform air bleeding procedure as necessary after replacing the steering gear or the steering fluid lines.

## &lt;2.0L Engine&gt;

## Required Special Tools:

- MB991955: M.U.T.-III Sub Assembly

1. Raise and support the front wheels.
2. Disconnect the crank angle sensor connector.

**CAUTION**

**Perform air bleeding only while cranking the engine. If air bleeding is performed while the engine is running, air could enter the fluid. During air bleeding, refill the steering fluid supply so that the level never falls below the lower mark on the dipstick.**

3. Turn the steering wheel all the way to the left and right five or six times while using the starter motor to crank the engine intermittently several times (for 15 to 20 seconds).
4. Connect the crank angle sensor connector.
5. Start the engine (idling).
6. Turn the steering wheel to the left and right until there are no air bubbles in the oil reservoir.
7. Confirm that the fluid is not milky, and that the level is between the high and low dipstick marks.
8. Confirm that there is very little change in the fluid level when the steering wheel is turned left and right.

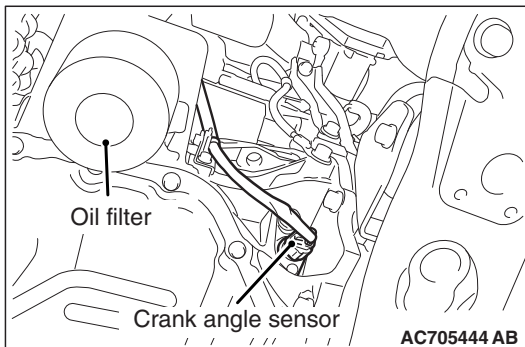

**CAUTION**

If the fluid level rises suddenly after the engine is stopped, the air has not been completely bled. If air bleeding is not complete, there will be abnormal noises from the pump and the flow-control valve, and this condition could cause reduce the life of the power steering components.

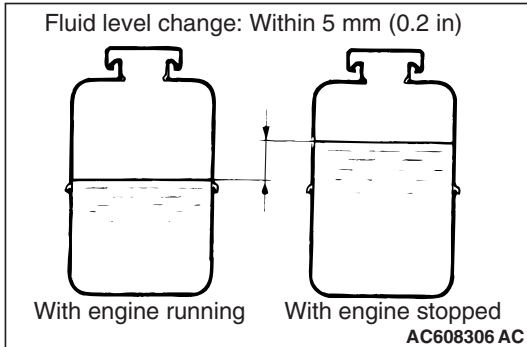

9. Confirm that the change in the fluid level is no more than 5 mm (0.2 inch) when the engine is stopped and when it is running.

10. If the change of the fluid level is 5 mm (0.2 inch) or more, the air has not been completely bled from the system. The air bleeding procedure must be repeated.

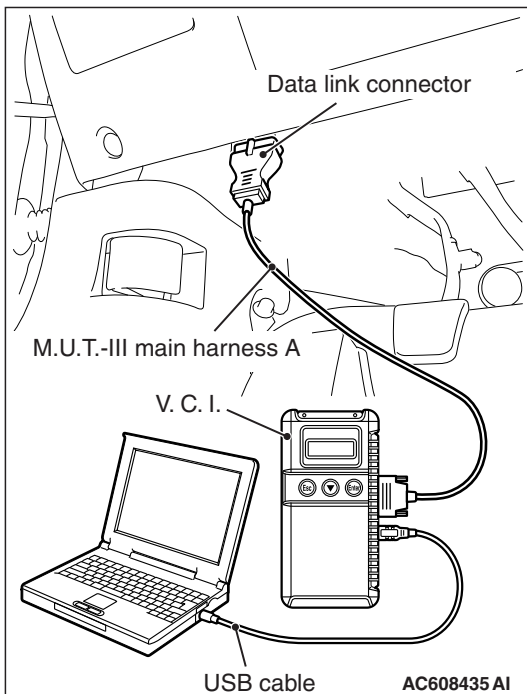

11. Use the M.U.T.-III, check if the DTC is set. If it is set, erase it.

## &lt;2.4L Engine&gt;

## Required Special Tools:

- MB991955: M.U.T.-III Sub Assembly

1. Raise and support the front wheels.
2. Disconnect the all of the injector connectors.

**⚠ CAUTION**

**Perform air bleeding only while cranking the engine. If air bleeding is performed while the engine is running, air could enter the fluid. During air bleeding, refill the steering fluid supply so that the level never falls below the lower mark on the dipstick.**

3. Turn the steering wheel all the way to the left and right five or six times while using the starter motor to crank the engine intermittently several times (for 15 to 20 seconds).
4. Connect the all of the injector connectors.
5. Start the engine (idling).
6. Turn the steering wheel to the left and right until there are no air bubbles in the oil reservoir.
7. Confirm that the fluid is not milky, and that the level is between the high and low dipstick marks.
8. Confirm that there is very little change in the fluid level when the steering wheel is turned left and right.

**⚠ CAUTION**

**If the fluid level rises suddenly after the engine is stopped, the air has not been completely bled. If air bleeding is not complete, there will be abnormal noises from the pump and the flow-control valve, and this condition could cause reduce the life of the power steering components.**

9. Confirm that the change in the fluid level is no more than 5 mm (0.2 inch) when the engine is stopped and when it is running.
10. If the change of the fluid level is 5 mm (0.2 inch) or more, the air has not been completely bled from the system. The air bleeding procedure must be repeated.

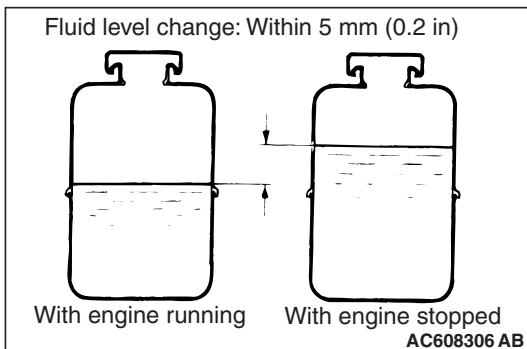
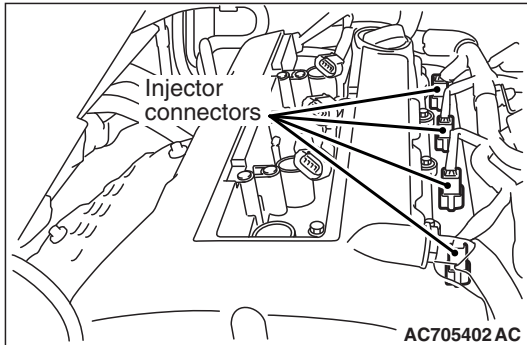

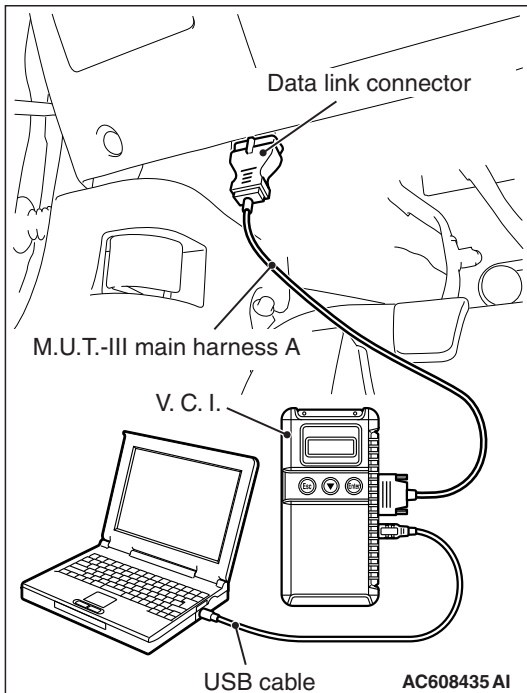

11. Use M.U.T.-III if the DTC is set or not. If the DTC is set, erase it.

## OIL PUMP PRESSURE TEST

M1372002300984

### Required Special Tools:

- MB990662: Power Steering Oil Pressure Gauge
- MB991548: Oil Pressure Gauge Adapter A (Pump Side)
- MB991549: Oil Pressure Gauge Adapter B (Hose Side)

1. Disconnect the pressure hose from the oil pump, and then connect the special tools MB991548, MB990662 and MB991549.
2. Bleed air, then turn the steering wheel several times while the vehicle is not moving so that the temperature of the fluid rises to approximately 50 –60° C (122 –140° F).
3. Start the engine and idle it at 1,000 ± 100 r/min.

### **CAUTION**

**The pressure gauge shut-off valve must not remain closed for more than 10 seconds.**

4. Fully close the shut-off valve of the pressure gauge and measure the oil pump relief pressure to confirm that it is within the standard value range. Open it again immediately after checking the pressure.

### Standard value

**8.1 –8.8 MPa (1,175 –1,276 psi) <2.0L Engine>**

**8.8 –9.5 MPa (1,276 –1,378 psi) <2.4L Engine>**

5. If it is not within the standard value, replace the oil pump.
6. Check whether or not the hydraulic pressure is the standard value when no-load conditions are created by fully opening the shut-off valve of the pressure gauge.

### Standard value

**1.0 MPa (145 psi) <2.0L Engine>**

**0.2 –0.7 MPa (29 –102 psi) <2.4L Engine>**

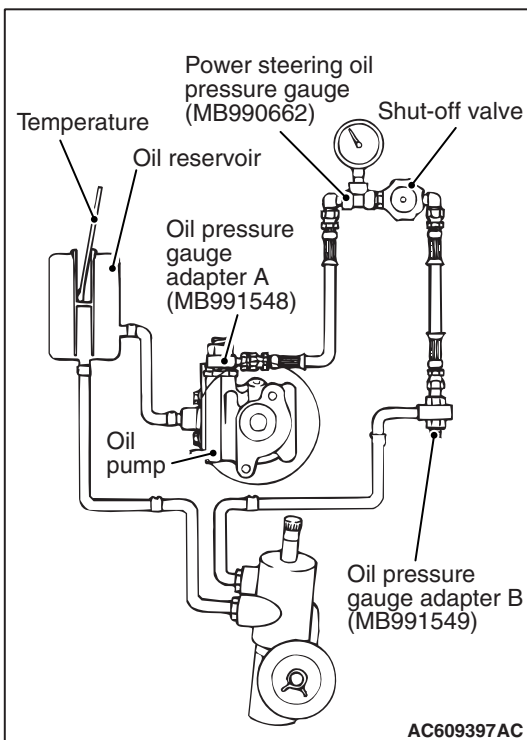

7. If it is not within the standard value, the probable cause is a malfunction of the oil line or steering gear, so check these parts and repair as necessary.
8. Turn the steering wheel all the way to the left or right; then check whether or not the retention hydraulic pressure is the standard value.

**Standard value**

**8.1 –8.8 MPa (1,175 –1,276 psi) <2.0L Engine>**

**8.8 –9.5 MPa (1,276 –1,378 psi) <2.4L Engine>**

9. If not the standard value, overhaul the steering gear. Remeasure fluid pressure.
10. Remove the special tools MB991548, MB990662 and MB991549, and then tighten the pressure hose to the specified torque.

**Tightening torque: 57 ± 7 N· m (42 ± 5 ft-lb)**

11. Bleed the system (Refer to P.37-26).

**POWER STEERING PRESSURE SWITCH CHECK**

M1372007200744

**Required Special Tools:**

- MB990662: Power Steering Oil Pressure Gauge
- MB991548: Oil Pressure Gauge Adapter A (Pump Side)
- MB991549: Oil Pressure Gauge Adapter B (Hose Side)

1. Disconnect the pressure hose from the oil pump, and then connect the special tools MB991548, MB990662 and MB991549.
2. Bleed air, and then turn the steering wheel several times while the vehicle is not moving so that the temperature of the fluid rises to approximately 50 –60° C (122 –140° F).
3. Start the engine and idle it at 1,000 ± 100 r/min.
4. Disconnect the connector for the oil pressure switch, and place an ohmmeter at the switch.
5. Gradually close the shut-off valve of the pressure gauge and increase the hydraulic pressure, then check whether or not the hydraulic pressure that activates the switch is the standard value.

**Standard value**

**2.5 –3.0 MPa (363 –435 psi) <2.0L Engine>**

**1.5 –2.0 MPa (218 –290 psi) <2.4L Engine>**

6. Gradually open the shut-off valve and reduce the hydraulic pressure; then check whether or not the hydraulic pressure that deactivates the switch is the standard value.

**Standard value**

**1.5 –3.0 MPa (218 –435 psi) <2.0L Engine>**

**0.5 –2.0 MPa (73 –290 psi) <2.4L Engine>**

7. Remove special tools MB991548, MB990662 and MB991549, connect the pressure hose to the oil pump, and then tighten the eye bolt to the specified torque.

**Tightening torque: 57 ± 7 N· m (42 ± 5 ft-lb)**

8. Bleed the system. (Refer to P.37-26).

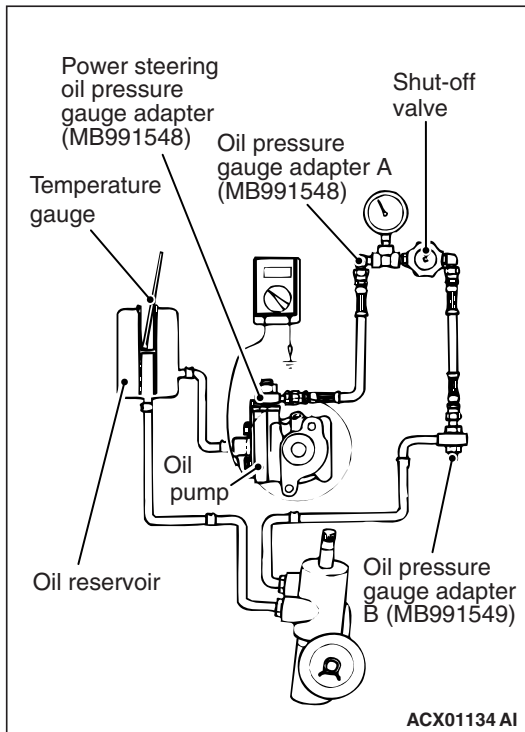

STEERING COLUMN SHAFT ASSEMBLY SHOCK  
ABSORBING MECHANISM CHECK

M1372013500647

**⚠ WARNING**

- ***If the vehicle continues to be driven after the collision absorbing mechanism has operated, the steering column shaft may be damaged while it is in use.***
- ***If there is a slack in the mounting base, do not attempt to repair it. Replace the steering column shaft assembly.***

If a collision accident occurs or severe impact is applied on the steering wheel, the collision energy absorbing mechanism may have operated. Once the mechanism has operated, it will be inoperative even if it has suffered no apparent damage. Determine if the steering column shaft can be reused by the following procedure. If the collision energy absorbing mechanism has already operated, replace the steering shaft assembly (Refer to P.37-36). If any excessive radial freeplay on the steering wheel is found with the tilt lever in the lock position, always inspect the steering shaft assembly.

Inspection procedure:

1. Remove the lower and upper column covers.

**⚠ CAUTION**

**After inspection, do not release the tilt lever until the steering shaft assembly has been installed.**

2. Ensure that the tilt lever is in the lock position.
3. Loosen the two upper steering column mounting bolts by two turns.
4. Hold the one-way capsules as shown, and then try to rock them. If there is a slack in either of the capsules, replace the steering column shaft assembly (Refer to P.37-36).

Reference:

The mounting base is fixed to the column bracket with the rivet. Before the collision energy absorbing mechanism operates, the column bracket is secured to the mounting base. After operation, the rivet will break off causing a slack.

**⚠ CAUTION**

- **Be careful that nothing is pinched between the mounting base and the body.**
  - **After inspection, do not release the tilt lever until the steering shaft assembly has been installed.**
5. After inspection, if there is no fault, tighten the two steering column upper side mounting bolts (2 bolts) to the specified torque.

**Tightening torque:  $12 \pm 3$  N·m ( $106 \pm 27$  in-lb)**

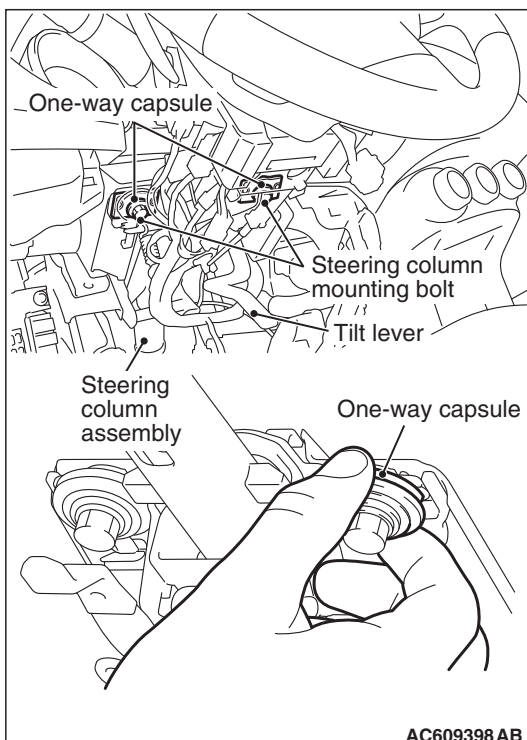

# STEERING WHEEL

## REMOVAL AND INSTALLATION

M1372011401595

**⚠ WARNING**

- Before removing the steering wheel and driver's air bag module assembly, refer to GROUP 52B, Service Precautions P.52B-26 and Driver's Air Bag Module and Clock Spring P.52B-414 or P.52B-422.
- When removing and installing the steering wheel, do not let it bump against the driver's air bag module.

**⚠ CAUTION**

After the installation, perform a calibration for the ASC-ECU to learn the steering wheel sensor neutral point. (Refer to GROUP 35C –On-vehicle Service –Steering Wheel Sensor Calibration P.35C-304).  
<Vehicles with ASC>

<p><b>Pre-removal Operation</b> Steering Wheel Straight-ahead Position Check</p>	<p><b>Post-installation Operation</b></p> <ul style="list-style-type: none"> <li>• Steering Wheel Straight-ahead Position Check</li> <li>• Steering Wheel Shake Check</li> </ul>
--	--

<2.0L Engine>

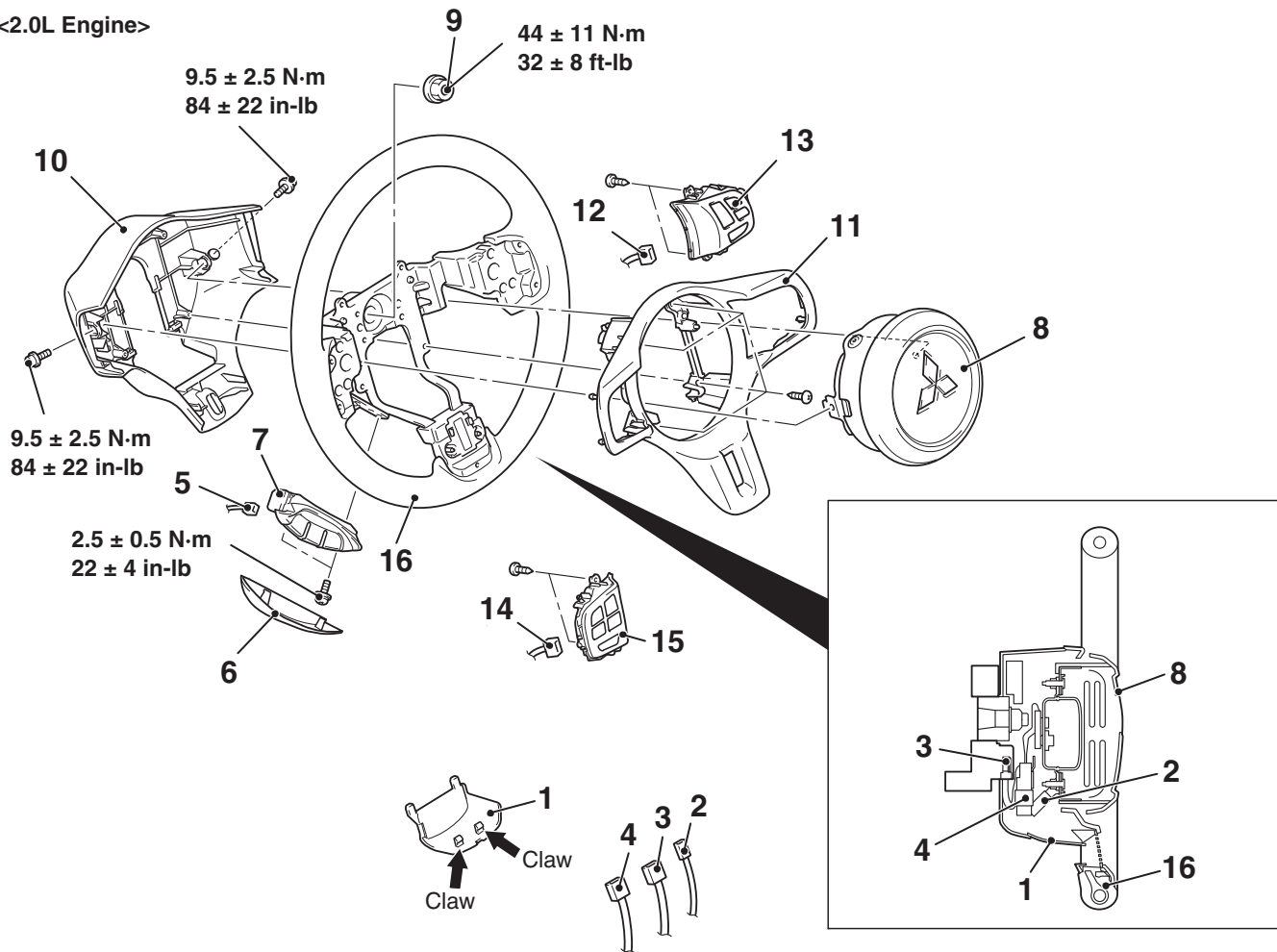

AC711459 AH

- |                          |   |   |  |
|--------------------------|---|---|--|
| <p>&lt;&lt;A&gt;&gt;</p> | <p><b>Removal steps</b></p> <ol style="list-style-type: none"> <li>1. Cover</li> <li>2. Horn connector connection</li> <li>3. Steering switch connector connection</li> </ol> | <p>&lt;&lt;B&gt;&gt;    &gt;&gt;B&lt;&lt;</p> | <p><b>Removal steps (Continued)</b></p> <ol style="list-style-type: none"> <li>4. Driver's air bag module connector connection</li> <li>5. Steering wheel voice control switch connector connection</li> </ol> |
|--------------------------|---|---|--|



**Removal steps (Continued)**

6. Steering wheel voice control switch cover
7. Steering wheel voice control switch
8. Driver's air bag module
9. Flange nut
10. Lower cover
11. Garnish

<<C>>

**Removal steps (Continued)**

12. Cruise control switch connector connection
13. Cruise control switch
14. Steering wheel audio remote control switch connector connection
15. Steering wheel audio remote control switch
16. Steering wheel assembly

<<D>> >>A<<

<2.4L Engine>

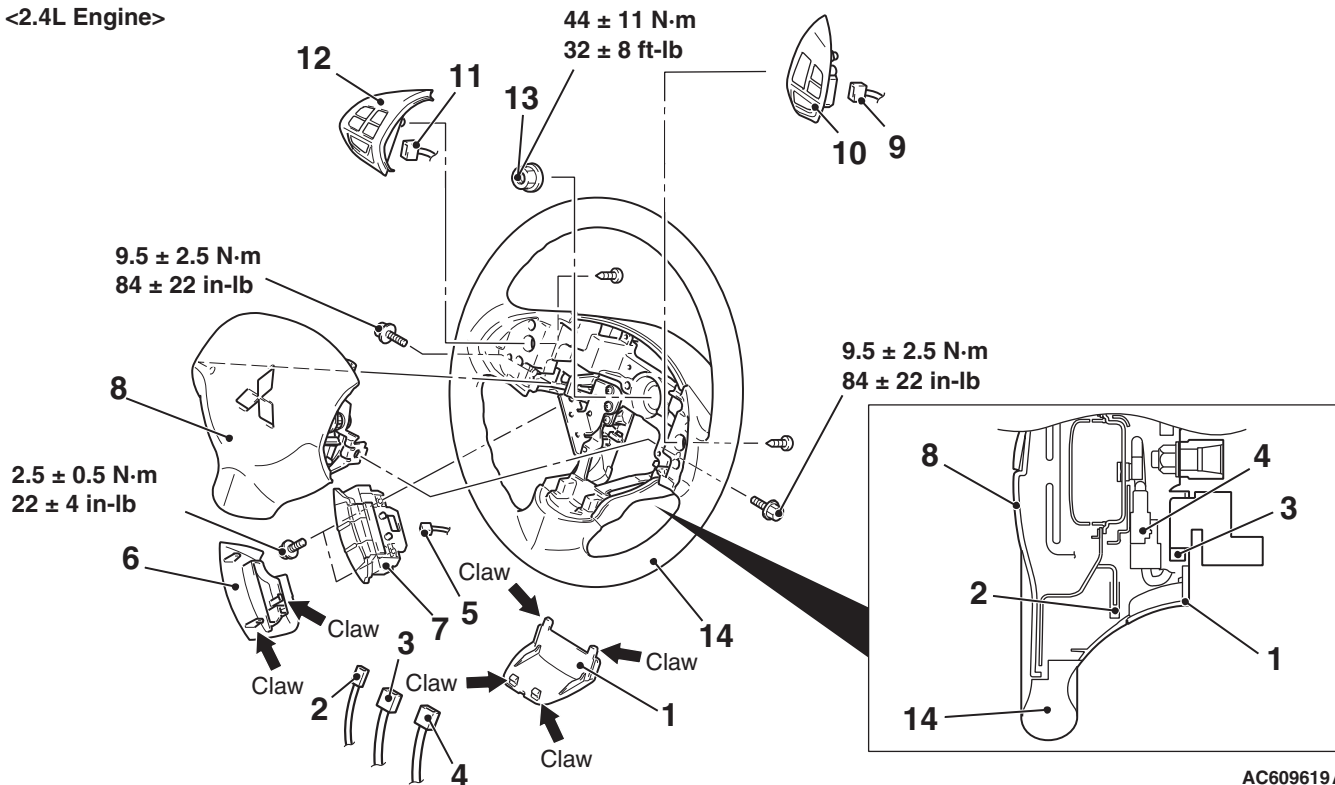

AC609619 AE

**Removal steps**

1. Cover
2. Horn connector connection
3. Steering switch connector connection
4. Driver's air bag module connector connection
5. Steering wheel voice control switch connector connection
6. Steering wheel voice control switch cover
7. Steering wheel voice control switch
8. Driver's air bag module

<<A>>

>>B<<

>>B<<

<<B>>

>>B<<

<<C>>

**Removal steps (Continued)**

9. Cruise control switch connector connection
10. Cruise control switch
11. Steering wheel audio remote control switch connector connection
12. Steering wheel audio remote control switch
13. Flange nut
14. Steering wheel assembly

<<D>> >>A<<

**Required Special Tools:**

- MB990784: Ornament Remover
- MB990803: Steering wheel puller

## REMOVAL SERVICE POINTS

## &lt;&lt;A&gt;&gt; COVER REMOVAL

Insert the special tool MB990784 at the indicated position to remove the cover.

*NOTE: The special tool MB990784 can be inserted through the notch behind the area shown.*

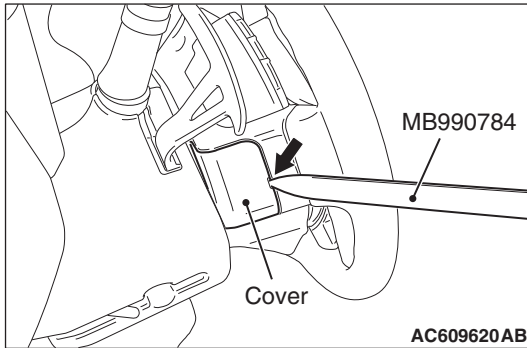
<<B>> DRIVER'S AIR BAG MODULE  
CONNECTOR DISCONNECTION

Slide the outer housing of the driver's air bag module connector in the arrow direction shown and disconnect the connector.

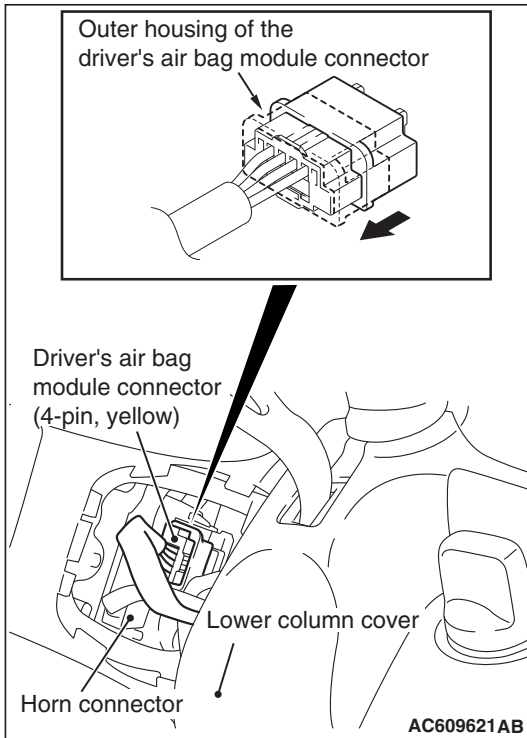

## &lt;&lt;C&gt;&gt; DRIVER'S AIR BAG MODULE REMOVAL

## ⚠ CAUTION

- Never use an electric tester to diagnose the air bag module circuit. Never attempt to disassemble the air bag module.
- Be sure to store removed air bag module in a clean and dry place with pad surface facing upward.

## <<D>> STEERING WHEEL ASSEMBLY REMOVAL

1. Position the steering wheel in a straight ahead position.

### CAUTION

- Use the special tool to remove the steering wheel since the steering column collision adsorbing mechanism may be damaged.
2. Use special tool MB990803 to remove the steering wheel.

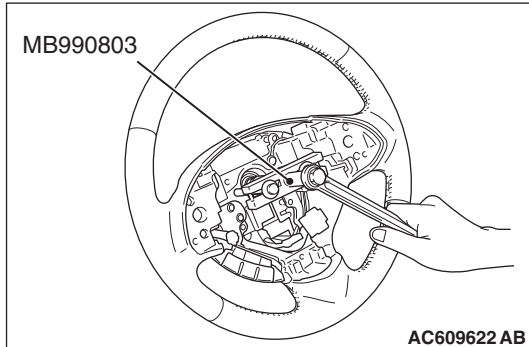

## INSTALLATION SERVICE POINTS

### >>A<< STEERING WHEEL ASSEMBLY INSTALLATION

After centering the clock spring (Refer to 52B –Air bag module clock spring), install the steering wheel assembly.

### >>B<< DRIVER'S AIR BAG MODULE CONNECTOR CONNECTION/STEERING SWITCH CONNECTOR CONNECTION/HORN CONNECTOR CONNECTION

Connect the connector securely and route the harnesses not to lie off the cover hole.

## STEERING COLUMN SHAFT ASSEMBLY

## REMOVAL AND INSTALLATION

M1372011501257

**CAUTION**

- Before removing the steering wheel, driver's air bag module assembly and Knee Air Bag Module refer to GROUP 52B, Service Precautions P.52B-26, Driver's Air Bag Module(s) and Clock Spring P.52B-414 or P.52B-422 and Knee Air Bag Module P.52B-434.
- After the installation, perform a calibration for the ASC-ECU to learn the steering wheel sensor neutral point. (Refer to GROUP 35C –On-vehicle Service –Steering Wheel Sensor Calibration P.35C-304). <Vehicles with ASC>

**Pre-removal Operation**

- Steering Wheel Assembly Removal (Refer to P.37-32).
- Instrument Panel Cover Lower Removal (Refer to GROUP 52A –Instrument Panel P.52A-8).
- Knee Air Bag Module Removal (Refer to GROUP 52B –Knee Air Bag Module P.52B-434).
- Front Floor Console and Console Side Panel Removal (Refer to GROUP 52A –Front Floor Console P.52A-3).

**Post-installation Operation**

- Front Floor Console and Console Side Panel Installation (Refer to GROUP 52A –Front Floor Console P.52A-3).
- Knee Air Bag Module Installation (Refer to GROUP 52B –Knee Air Bag Module P.52B-434).
- Instrument Panel Cover Lower Installation (Refer to GROUP 52A –Instrument Panel P.52A-8).
- Steering Wheel Assembly Installation (Refer to P.37-32).

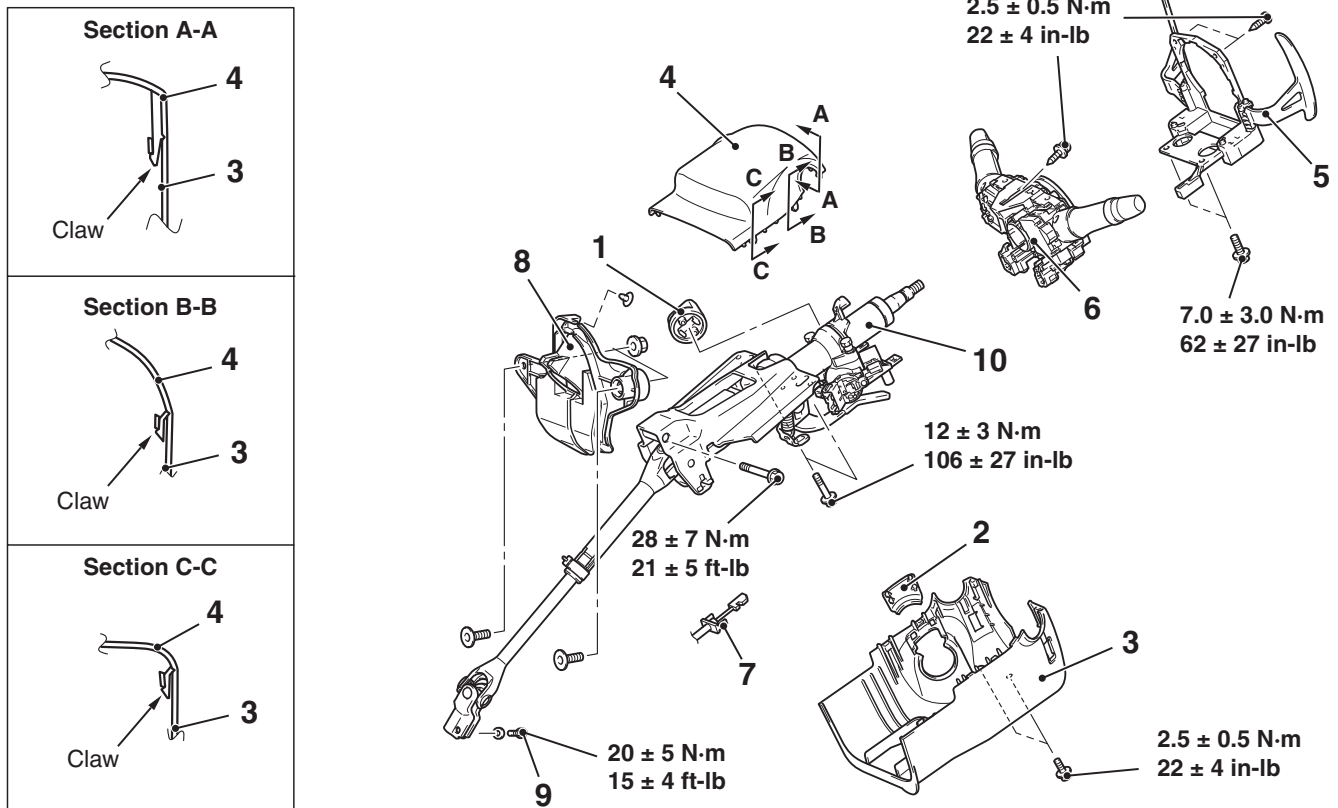

Note: claw position is symmetrical

AC709222 AG

&lt;&lt;A&gt;&gt;

**Removal steps**

1. Knob cap <Vehicles with KOS>
2. Ignition key cover
3. Steering column lower cover
4. Steering column upper cover
5. Paddle shift assembly <Vehicles with paddle shift>

**Removal steps (Continued)**

6. Clock spring column switch assembly

**Removal steps (Continued)**

- |       |       |  |
|-------|-------|--|
|       |       | 7. Key interlock cable (Refer to GROUP 23A - CVT Key Interlock And Shiftlock Mechanisms P.23A-150 <CVT>, Refer to 22C - TC-SST Key Interlock and Shiftlock Mechanisms P.22C-493 <TC-SST>). |
| <<B>> | >>B<< | 8. Steering shaft cover  |
|       |       | 9. Steering column bolt (steering column shaft assembly and steering gear and linkage connection)  |
| <<C>> | >>A<< | 10. Steering column shaft assembly   |

**REMOVAL SERVICE POINTS**

**<<A>> KNOB CAP REMOVAL**

Remove the knob cap while pressing the two projections.

**<<B>> STEERING SHAFT COVER REMOVAL**

1. Remove the clip (for securing the floor carpet), and turn back the floor carpet.
2. Remove the clip (for securing the steering shaft cover), and then remove the steering shaft cover.

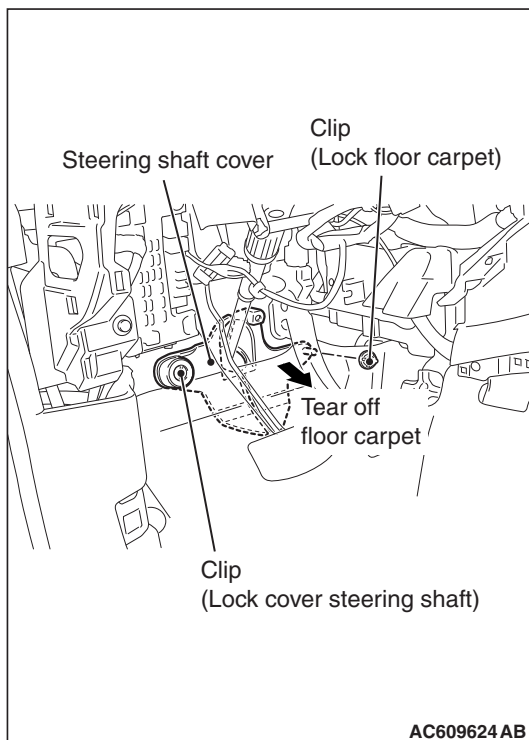

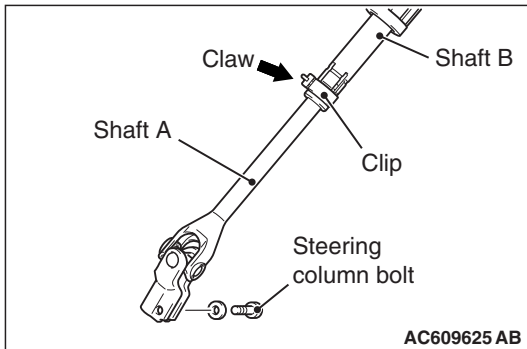
**<<C>> STEERING COLUMN SHAFT ASSEMBLY  
DISCONNECTION**

1. Remove the steering column bolt connecting the steering gear to the steering column assembly.
2. Disconnect the steering gear from the steering column assembly while sliding the shaft A to the shaft B with the clip claw as shown in the figure is pinched.
3. Remove the steering column mounting bolt.

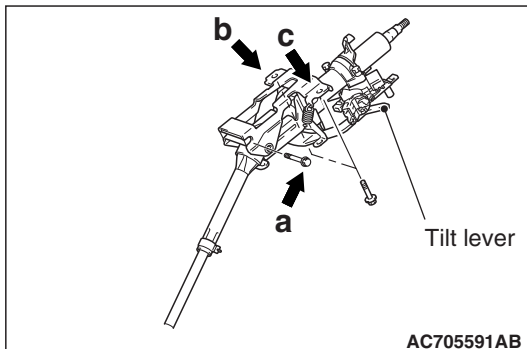
**INSTALLATION SERVICE POINTS****>>A<< STEERING COLUMN SHAFT ASSEMBLY  
INSTALLATION**

1. Ensure that the tilt lever is in the lock position.
2. Temporarily tighten the mounting bolts in the order of a, b, and c, and then tighten them in the order of c, b, and a to the specified torque.

**Tightening torque a:  $28 \pm 7$  N·m ( $21 \pm 5$  ft-lb)**

**Tightening torque b,c:  $12 \pm 3$  N·m ( $106 \pm 27$  in-lb)**

**>>B<< STEERING COLUMN BOLT (STEERING COLUMN SHAFT ASSEMBLY AND STEERING GEAR & LINKAGE CONNECTION) INSTALLATION**

1. While sliding shaft A from shaft B with the clip claw as shown in the figure being pinched, connect the steering column shaft assembly and the steering gear and linkage.
2. Insert the steering column bolt from the no tapped bolt hole, and tighten it to the specified torque.

**Tightening torque :  $20 \pm 5 \text{ N} \cdot \text{m}$  ( $15 \pm 4 \text{ ft} \cdot \text{lb}$ )**

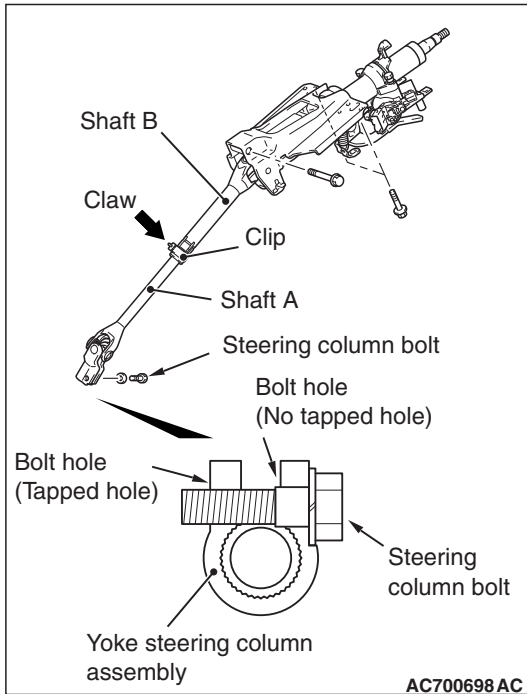

**DISASSEMBLY AND ASSEMBLY**

M1372011700548

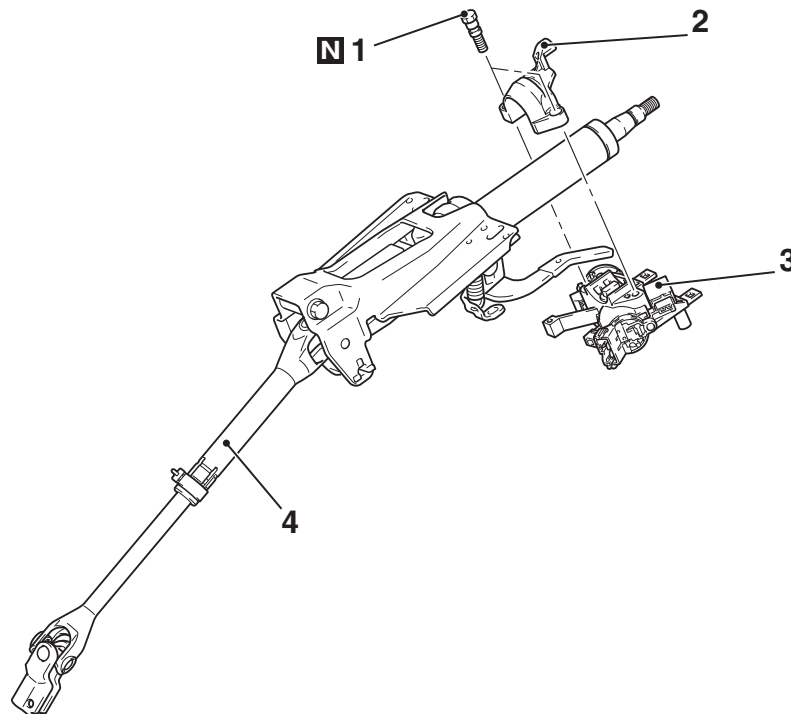

AC613519AC

- <<A>>    >>A<<  
>>A<<
- Disassembly steps**
1. Steering lock bolt
  2. Steering lock bracket

- >>A<<
- Disassembly steps**
3. Steering lock cylinder assembly
  4. Steering column shaft assembly

**DISASSEMBLY SERVICE POINT****<<A>> STEERING LOCK BOLT REMOVAL**

1. Use a drill to make a hole just deeply enough for the tap to stand on the steering lock bolt.
2. Use a left-hand thread tap to remove the steering lock bolt.

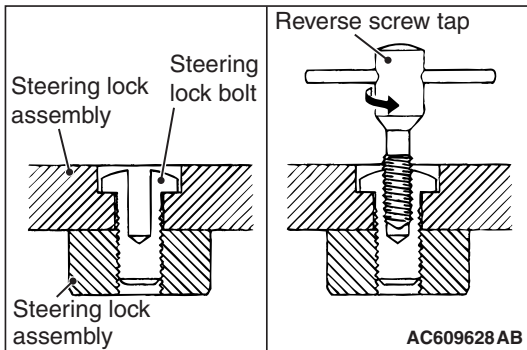
**ASSEMBLY SERVICE POINT****>>A<< STEERING LOCK CYLINDER ASSEMBLY/STEERING LOCK BRACKET/STEERING LOCK BOLT INSTALLATION**

1. When installing the steering lock assembly to the steering column shaft assembly, temporarily assemble the steering lock assembly while aligning it with the boss on the column.
2. Make sure that the steering lock operates normally, and then tighten the steering lock bolt until its head is broken off.

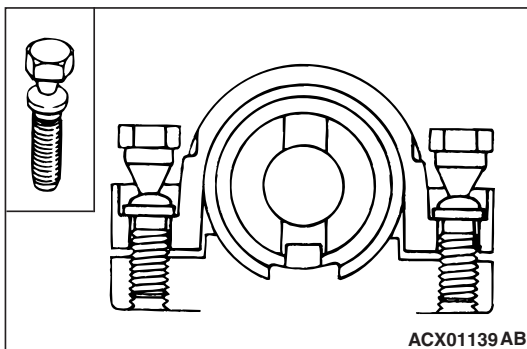



## POWER STEERING GEAR BOX AND LINKAGE

### REMOVAL AND INSTALLATION

M1372010901597

#### CAUTION

- Before removing the steering gear, refer to GROUP 52B, Service Precautions (P.52B-26) and Driver's Air Bag Module and Clock Spring (P.52B-414 or P.52B-422). Center the front wheels. Failure to do so may damage the SRS clock spring and render the SRS system inoperative, risking serious injury.
- The bolts and nuts marked with \* are coated with the friction coefficient stabilizer. When removing these parts, make sure that they are free of damage, remove any dust and dirt on the bearing surfaces and the threads, and tighten to the specified torque.
- After installation, perform a calibration for the ASC-ECU to learn the steering wheel sensor neutral point. (Refer to GROUP 35C –On-vehicle Service, Steering Wheel Sensor Calibration P.35C-304 <Vehicles with ASC>.

#### Pre-removal Operation

- Power Steering Fluid Draining (Refer to P.37-25).
- Steering Wheel Assembly and Air Bag Module Removal (Refer to P.15-31).
- Steering Shaft Cover Removal (Refer to P.32-13).
- Engine Room Under Cover Front (A, B), Engine Room Side Cover, Front Floor Panel Rear Removal (Refer to GROUP 51 –Under Cover P.51-20).
- Front Roll Stopper and Centermember Assembly Removal (Refer to GROUP 32 –Engine Roll Stopper and Centermember P.32-13).

#### Post-installation Operation

- Front Roll Stopper and Centermember Assembly Installation (Refer to GROUP 32 –Engine Roll Stopper and Centermember P.32-13).
- Engine Room Under Cover Front (A, B), Engine Room Side Cover, Front Floor Panel Rear Installation (Refer to GROUP 51 –Under Cover P.51-20).
- Steering Shaft Cover Installation (Refer to P.32-13).
- Steering Wheel Assembly and Air Bag Module Installation (Refer to P.15-31).
- Power Steering Fluid Refilling and Bleeding (Refer to P.37-25).
- Steering Wheel Straight-ahead Position Check
- Steering Wheel Play Check (Refer to P.37-17).
- Wheel Alignment Check and Adjustment (Refer to GROUP 33 –On-vehicle Service –Front Wheel Alignment Check and Adjustment P.33-8).

**POWER STEERING  
POWER STEERING GEAR BOX AND LINKAGE**

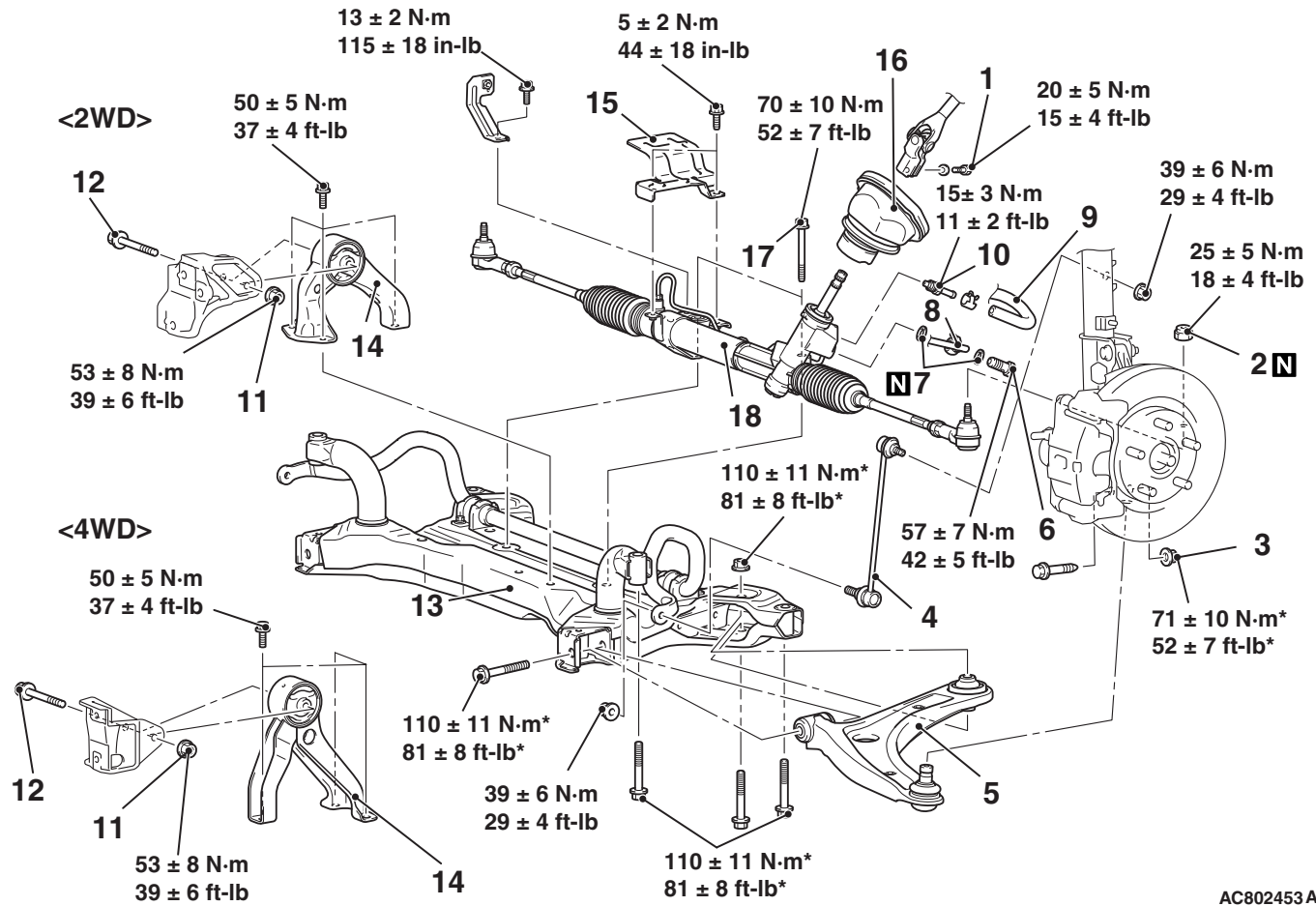

AC802453 AB

<<A>>

- Removal steps**
1. Steering column bolt
  2. Jam nut (Tie-rod end and knuckle connection)
  3. Flange nut (Lower arm and knuckle connection)
  4. Stabilizer link
  5. Lower arm assembly
  6. Eye bolt
  7. Gasket
  8. Pressure hose connection
  9. Return hose connection
  10. Return tube assembly

<<B>>

>>A<<

- Removal steps (Continued)**
11. Flange nut
  12. Rear roll stopper center bolt
  13. Front axle crossmember
  14. Rear roll stopper
  15. Heat protector
  16. Joint cover grommet
  17. Flanged bolt
  18. Steering gear and linkage

**Required Special Tool:**

- MB991897 or MB992011: Ball Joint Remover

## REMOVAL SERVICE POINTS

### <<A>> JAM NUT (TIE-ROD END AND KNUCKLE CONNECTION) REMOVAL

#### ⚠ CAUTION

- Loosen the jam nut (tie-rod end connection) from the ball joint, but do not remove here. Use the special tool.
- To prevent the special tool from dropping off, suspend it with a cord.

1. Install special tool MB991897 or MB992011 as shown in the figure.

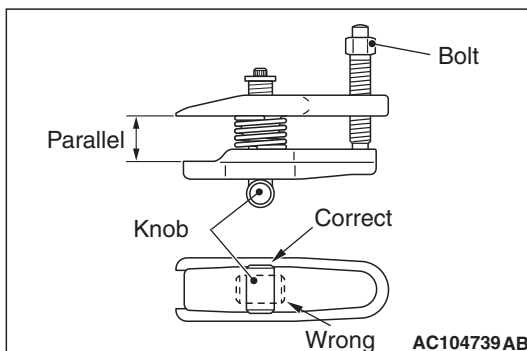
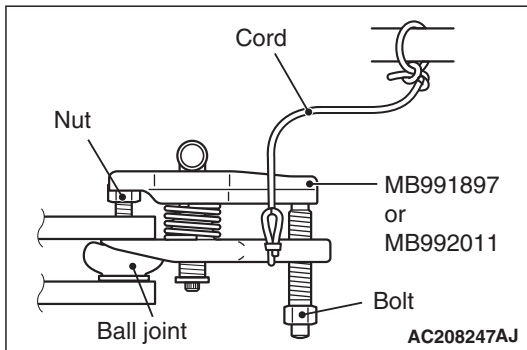

2. Turn the bolt and knob to make the special tool jaws parallel, then hand-tighten the bolt. After tightening, check that the jaws are still parallel.

*NOTE: To adjust the special tool jaws to be parallel, set the orientation of the knob as shown in the figure.*

3. Unscrew the bolt to disconnect the ball joint.

### <<B>> FRONT AXLE CROSSMEMBER REMOVAL

1. Jack up and support the crossmember, and remove it.
2. Check the hoses and harnesses for roughness, and then remove the front suspension crossmember with the rear roll stopper and the steering gear and linkage installed.

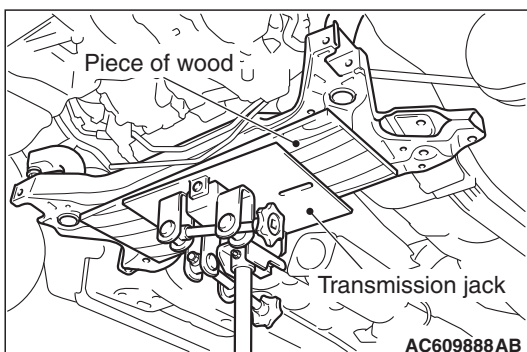

## INSTALLATION SERVICE POINT

## &gt;&gt;A&lt;&lt; JOINT COVER GROMMET INSTALLATION

Install the joint cover grommet to the steering gear and linkage by aligning L mark and the protrusion part of gearbox as shown in the figure.

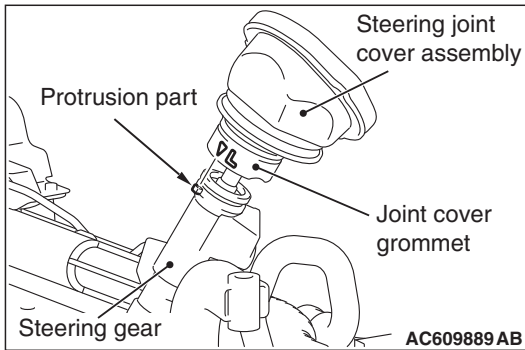

## INSPECTION

M1372011001412

## PINION TOTAL ROTATION TORQUE CHECK

## Required Special Tools:

- MB991006: Preload Socket

**⚠ CAUTION**

Secure the steering gear and linkage to the special mounting point. Fixing the steering gear and linkage to another point could deform or damage the gear housing.

1. Using the special tool preload socket (MB991006) to rotate the pinion at a rate of one turn per 4 to 6 seconds, and then measure the pinion total rotation torque.

**Standard value:**

**Total rotation torque: 1.0 –2.0 N· m (8.9 –17.7 in-lb)**

**Torque fluctuation: 0.4 N· m (3.5 in-lb) or less**

**NOTE:**

- During measurement, remove the bellows from the gear housing.
  - Rotate the pinion by 180° in left and right directions from the neutral position, and measure the pinion total rotation torque.
2. If the measurement value is outside the standard value, replace the gear housing.

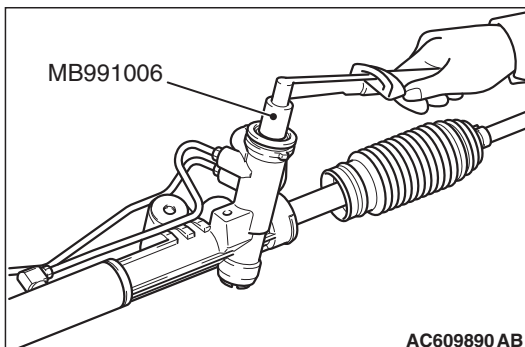

DISASSEMBLY AND ASSEMBLY

M1372011101099

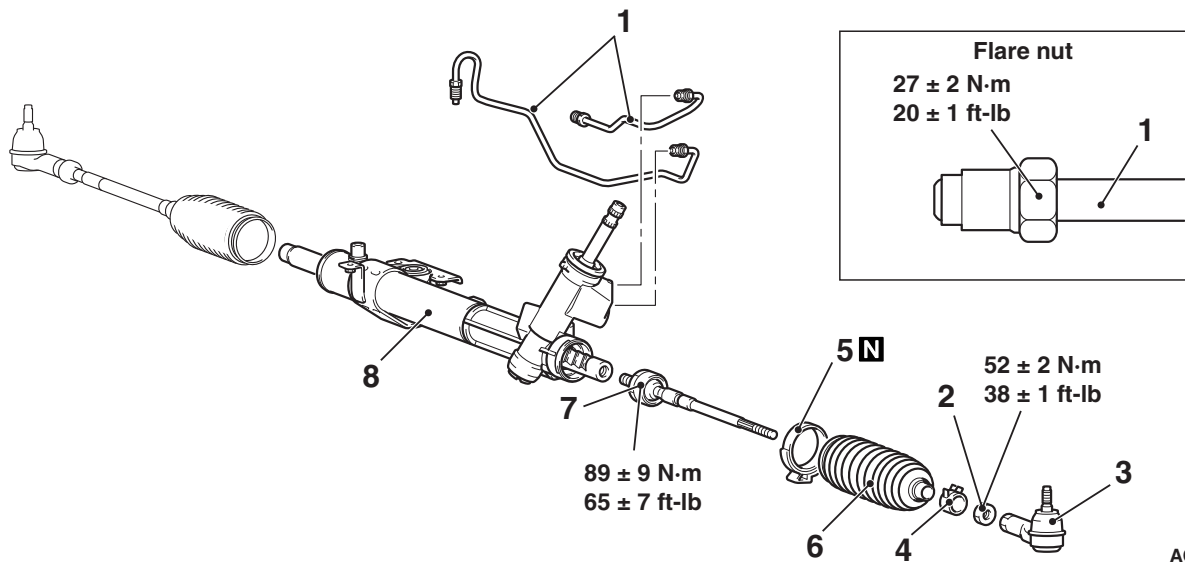

- Disassembly steps**
- >>C<< 1. Feed pipe
  - >>C<< 2. Jam nut
  - >>C<< 3. Tie-rod end
  - 4. Clip

- Disassembly steps**
- >>B<< 5. Band
  - 6. Bellows
  - <<A>> >>A<< 7. Tie-rod
  - 8. Gear housing

**Required Special Tool:**

- MB992209: Boot band clipping tool
- MB992249: Variable spanner

**LUBRICATION AND SEALING POINTS**

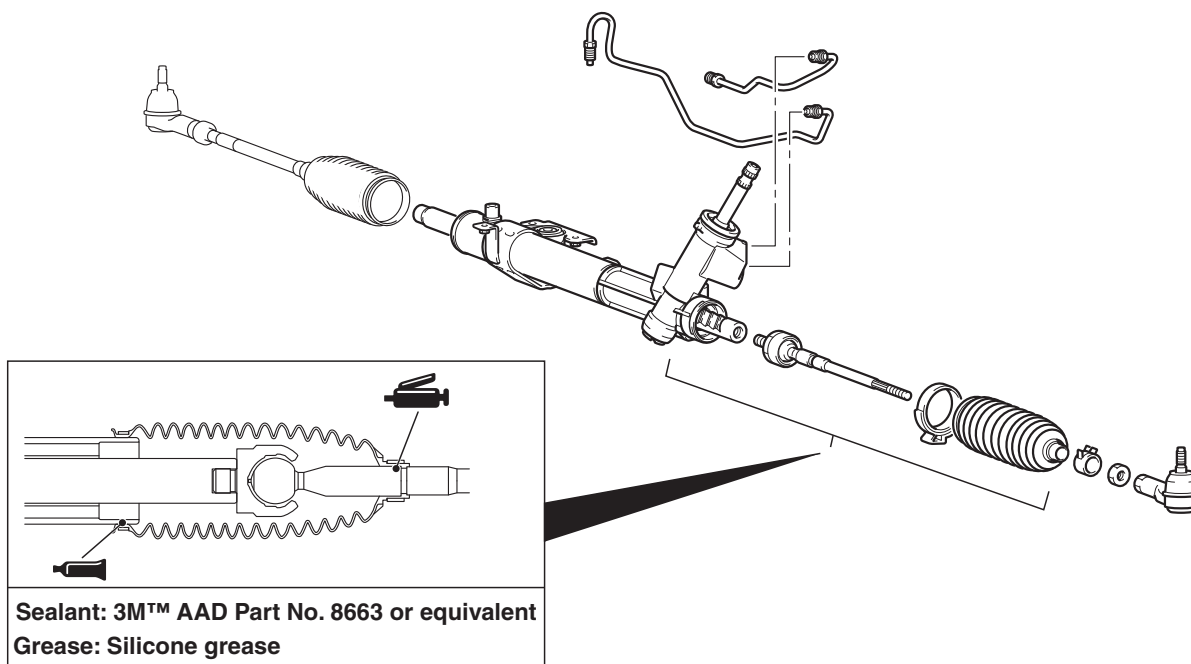

AC609895 AC

## DISASSEMBLY SERVICE POINT

## &lt;&lt;A&gt;&gt; TIE-ROD REMOVAL

1. Move the bellows and pull the rack bar toward arrow direction.

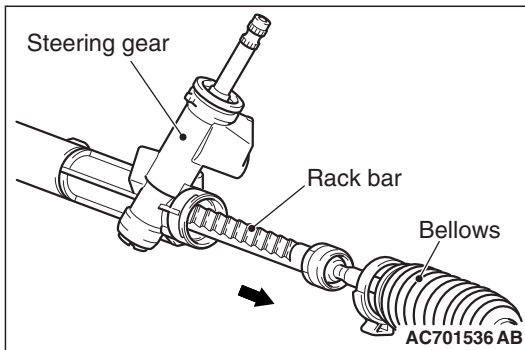

## ⚠ CAUTION

Do not tighten the vise strongly in order not to damage the rack bar.

2. Wrap rack bar with cloth in order not to damage, and fix the rack bar with a vise.
3. Use special tool variable spanner (MB992249) to remove the tie-rod.

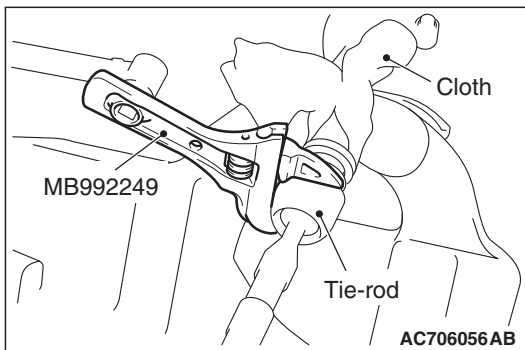

## ASSEMBLY SERVICE POINTS

## &gt;&gt;A&lt;&lt; TIE-ROD INSTALLATION

## ⚠ CAUTION

Do not tighten the vise strongly in order not to damage the rack bar.

1. Wrap rack bar with cloth in order not to damage, and fix the rack bar with a vise.
2. Use special tool variable spanner (MB992249) to tighten the tie-rod to the specified torque.

**Tightening torque:  $89 \pm 9 \text{ N} \cdot \text{m}$**

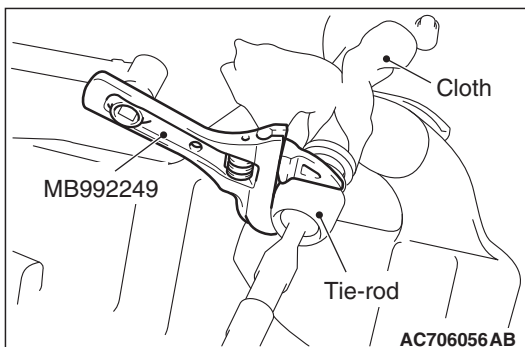

## >>B<< BAND INSTALLATION

### ⚠ CAUTION

- Secure the rack housing, and firmly crimp the bellows band by the bellows band clipping tool (special tool: MB992209).
- Crimp the bellows band securely until the special tool (MB992209) contacts the stopper.

1. Using the special tool (MB992209), crimp the bellows band.

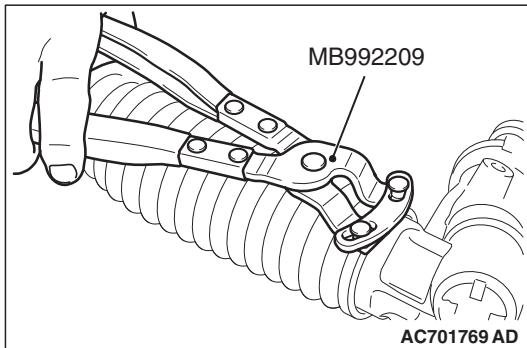

2. Check that the crimping width of the band (A) is within the range of the standard value.

**Standard value (A): 2.4 –2.8 mm (0.09 –0.11 in)**

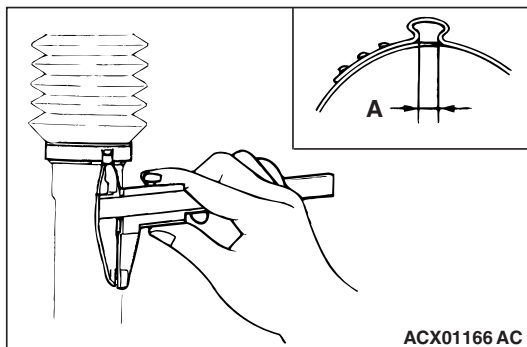

## >>C<< TIE-ROD END/JAM NUT INSTALLATION

Screw in the tie-rod to the length shown in the figure, and hand-tighten the jam nut.

*NOTE: Install the steering gear and linkage to the body, adjust the toe-in, and then tighten the jam nut to the specified torque.*

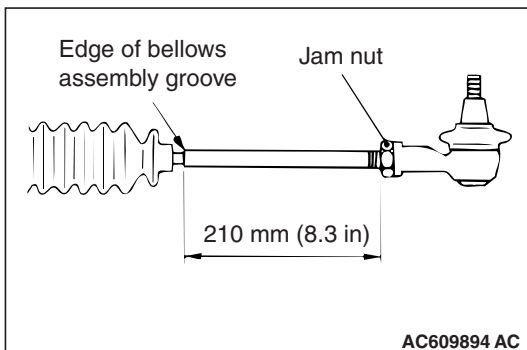

# POWER STEERING OIL PUMP ASSEMBLY

## REMOVAL AND INSTALLATION

M1372005201785

### Pre-removal Operation

- Power Steering Fluid Draining (Refer to P.37-25).
- Engine Upper Cover Removal (Refer to GROUP 11C – Camshaft P.11C-24 <2.4L Engine>).
- Radiator Condenser Tank Removal (Refer to GROUP 14 – Radiator P.14-50 <2.0L Engine> or P.14-53 <2.4L Engine>).
- Generator and Others Belt Removal (Refer to GROUP 11A –Crankshaft Pulley P.11A-22 <2.0L Engine>, GROUP 11C –Crankshaft Pulley P.11C-19 <2.4L Engine>).

### Post-installation Operation

- Generator and Others Belt Installation (Refer to GROUP 11A –Crankshaft Pulley P.11A-22 <2.0L Engine>, GROUP 11C –Crankshaft Pulley P.11C-19 <2.4L Engine>).
- Radiator Condenser Tank Installation (Refer to GROUP 14 –Radiator P.14-50 <2.0L Engine> or P.14-53 <2.4L Engine>).
- Engine Upper Cover Installation (Refer to GROUP 11C – Camshaft P.11C-24 <2.4L Engine>).
- Generator and Drive Belt Tension Check (Refer to GROUP 11A –On-vehicle Service –Drive Belt Tension Check P.11A-9 <2.0L Engine>, GROUP 11C –On-vehicle Service –Generator and Others Belt Tension Check P.11C-8 <2.4L Engine>).
- Power Steering Fluid Supplying and Bleeding (Refer to P.37-26).

<2.0L Engine>

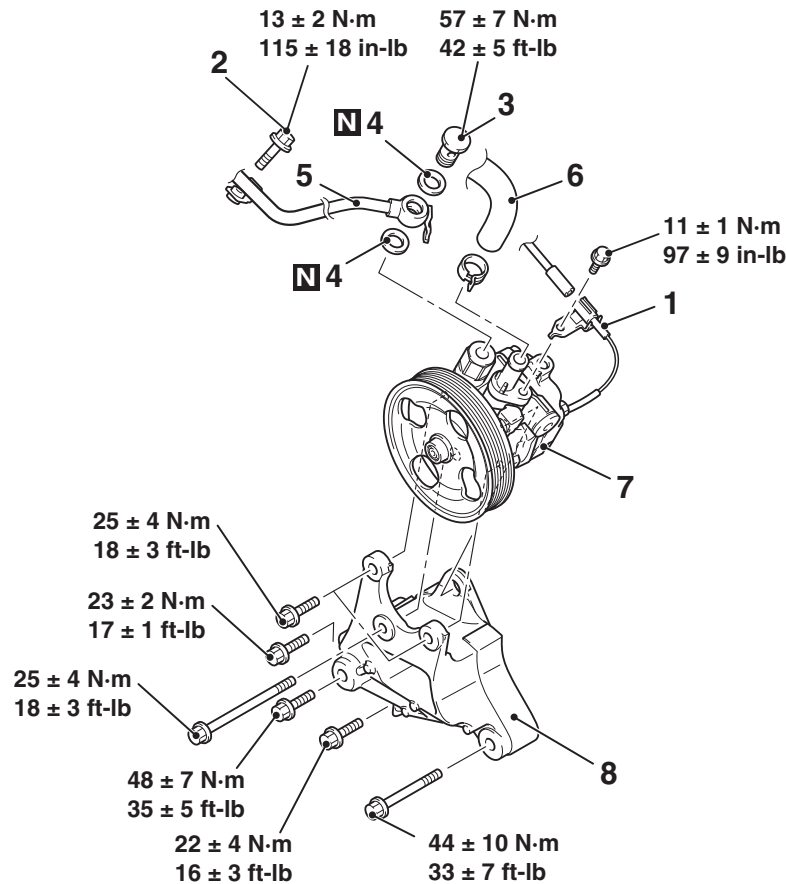

### Removal steps

1. Pressure switch connector connection
2. Clamp bolt
3. Eye bolt
4. Gasket

### Removal steps (Continued)

5. Pressure hose assembly connection
6. Suction hose connection
7. Oil pump assembly
8. Oil pump bracket

>>A<<

AC711515 AK



<2.4L Engine>

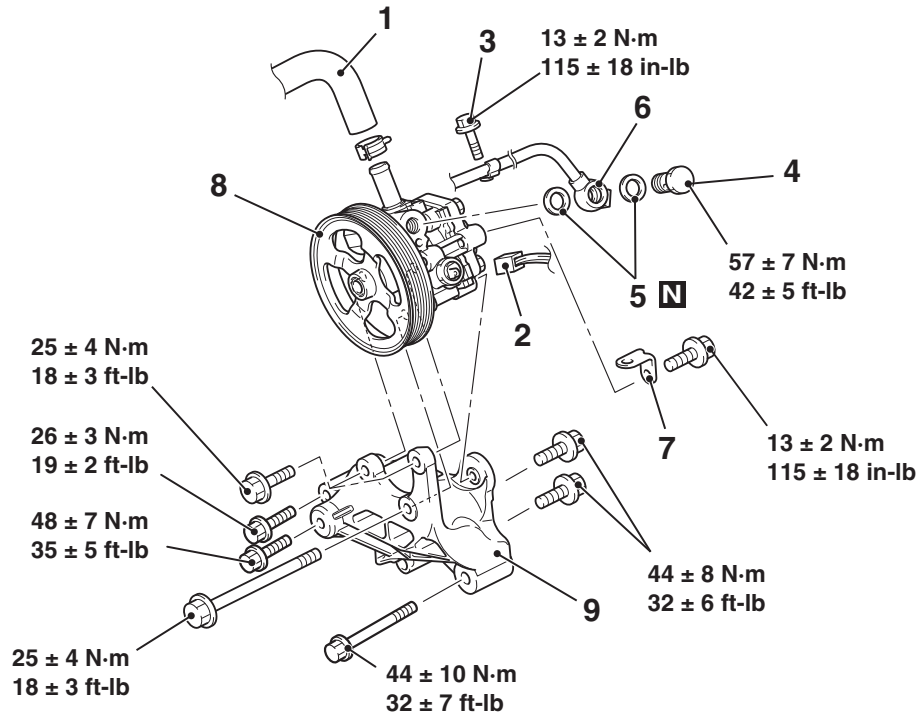

AC711076 AH

>>A<<

**Removal steps**

1. Suction hose connection
2. Pressure switch connector connection
3. Clamp bolt
4. Eye bolt
5. Gasket

**Removal steps (Continued)**

6. Pressure hose assembly connection
7. Harness bracket
8. Oil pump assembly
9. Oil pump bracket

## INSTALLATION SERVICE POINT

## &gt;&gt;A&lt;&lt; SUCTION HOSE CONNCTION

Align the suction hose marking within the area shown in the figure and connect the suction hose.

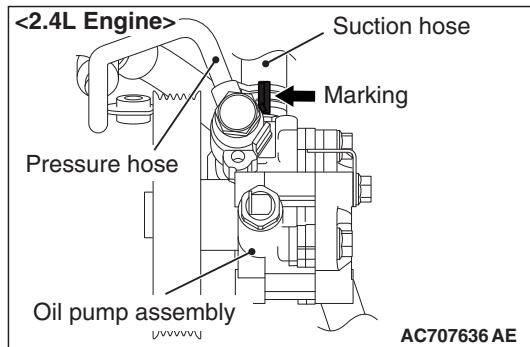
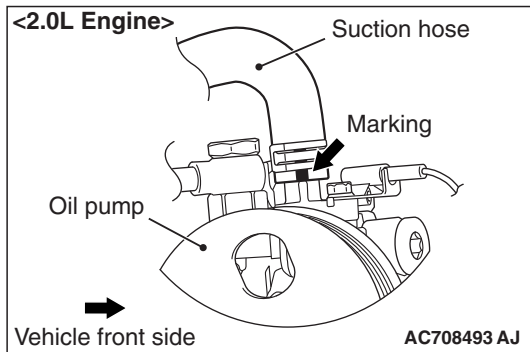

## INSPECTION

- Check the drive belt for cracks.
- Check the pulley for uneven rotation.

M1372005300347

DISASSEMBLY AND ASSEMBLY <2.4L Engine>

**CAUTION**

- Do not use ATF-SP II M and ATF-SP III for the power steering fluid.

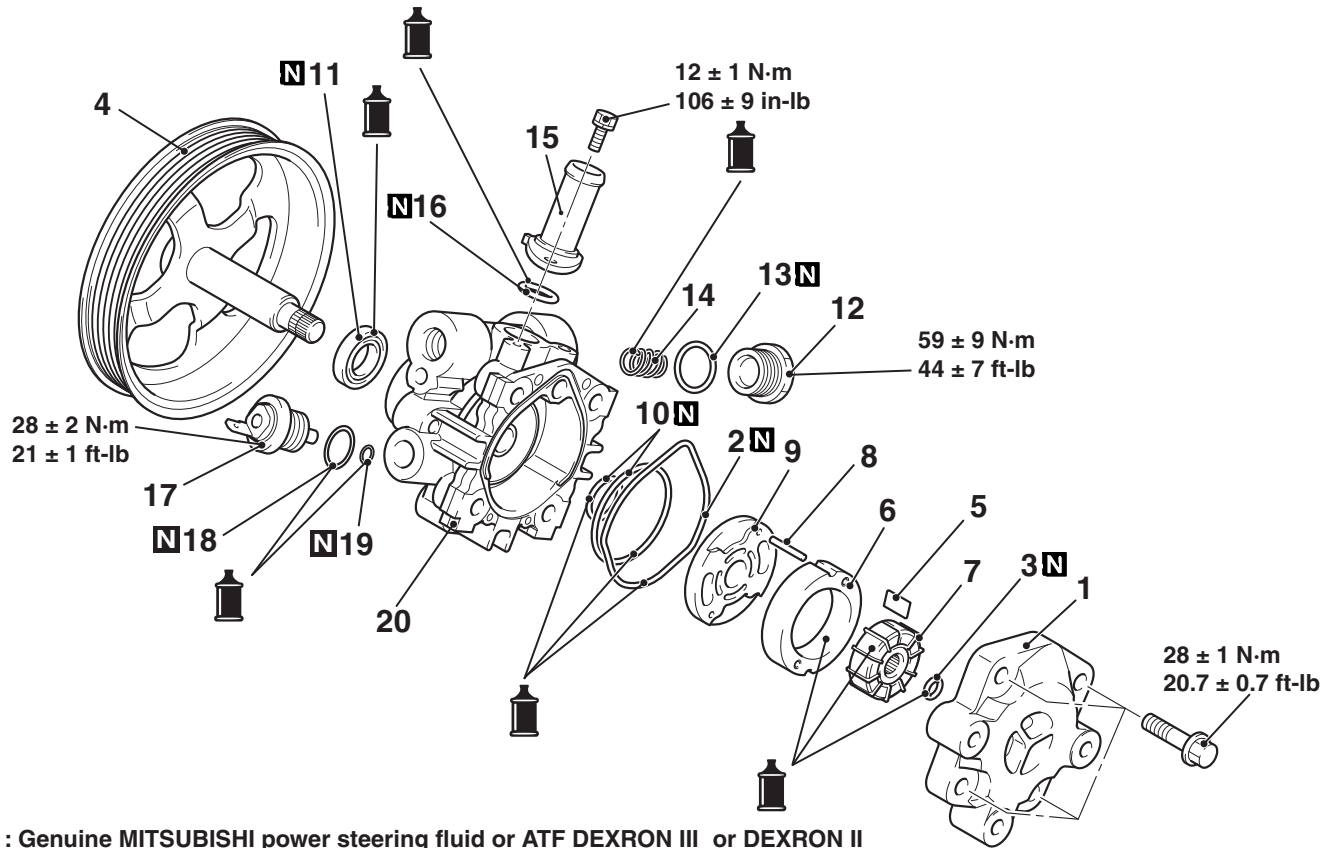

AC505810AP

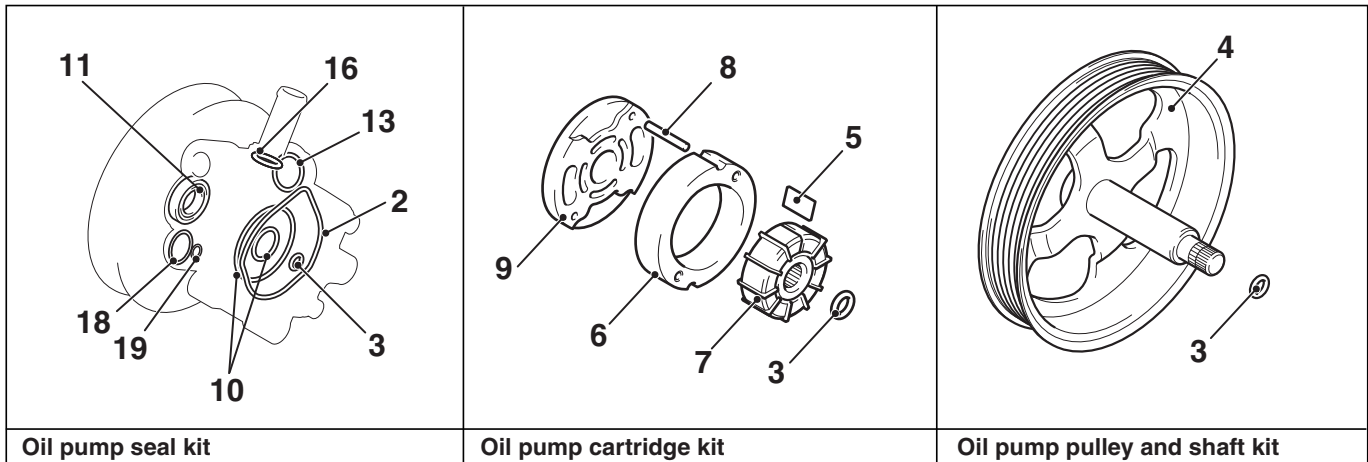

- |       |                          |       |                          |
|-------|--------------------------|-------|--------------------------|
|       | <b>Disassembly steps</b> |       | <b>Disassembly steps</b> |
|       | 1. Pump cover            | >>B<< | 11. Oil seal             |
|       | 2. O-ring                |       | 12. Plug assembly        |
|       | 3. Snap ring             | >>A<< | 13. O-ring               |
|       | 4. Pulley and shaft      |       | 14. Flow control spring  |
|       | 5. Vane                  |       | 15. Suction connector    |
| >>C<< | 6. Cam ring              | >>A<< | 16. O-ring               |
|       | 7. Rotor                 |       | 17. Terminal assembly    |
|       | 8. Pin                   |       | 18. O-ring               |
|       | 9. Side plate            |       | 19. O-ring               |
| >>A<< | 10. O-ring               |       | 20. Oil pump case        |

**Required Special Tool:**

- MB990938: Installer bar (MB990925: Including in the bearing and oil seal installer set)
- MB991203: Oil seal and bearing installer

**ASSEMBLY SERVICE POINTS**

**>>A<< O-RING INSTALLATION**

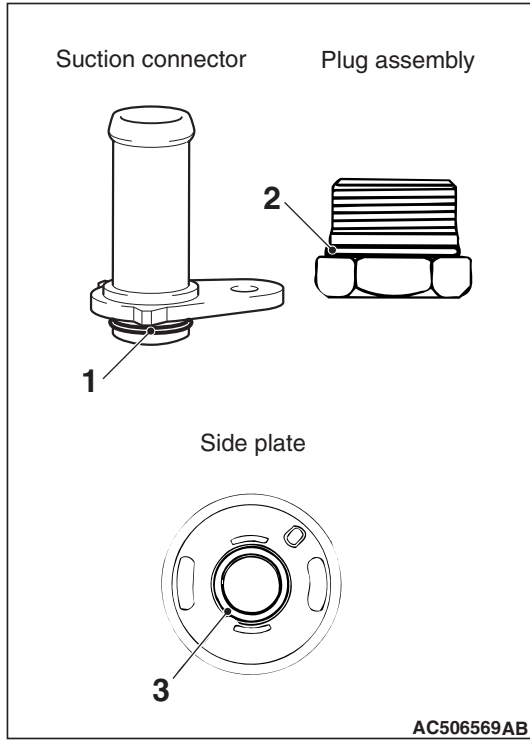

No.	Internal diameter x Width mm (in)
1	15.8 x 2.4 (0.62 x 0.09)
2	21.0 x 1.9 (0.83 x 0.07)
3	14.8 x 1.9 (0.58 x 0.07)

**>>B<< OIL SEAL INSTALLATION**

Use the following special tools to install the oil seal.

- Installer bar (MB990938) [Including in the bearing and oil seal installer set (MB990925)]
- Oil seal and bearing installer (MB991203)

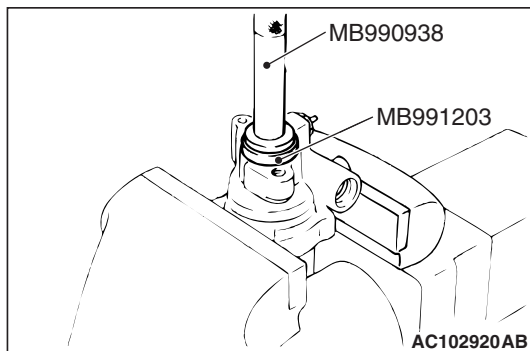

## >>C<< CAM RING INSTALLATION

**⚠ CAUTION**

Cam ring can be assembled only in a particular direction.

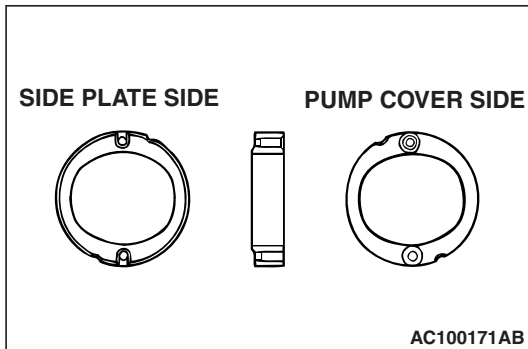

## INSPECTION

M1372005500404

- Check the pulley and shaft for wear or damage.
- Check the rotor and vane groove for "stepped" wear.
- Check the contact surface of cam ring and vanes for "stepped" wear.
- Check the vanes for damage.

## POWER STEERING HOSES

## REMOVAL AND INSTALLATION

M1372005702125

**Pre-removal Operation**

- Power Steering Fluid Draining (Refer to [P.37-25](#)).
- Engine Upper Cover Removal (Refer to GROUP 11C – Camshaft [P.11C-24](#) <2.4L Engine>).
- Radiator Condenser Tank Removal (Refer to GROUP 14 – Radiator [P.14-50](#) <2.0L Engine> or [P.14-53](#) <2.4L Engine>).
- Generator and Others Belt Removal (Refer to GROUP 11A – Crankshaft Pulley [P.11A-22](#) <2.0L Engine>, GROUP 11C – Crankshaft Pulley [P.11C-19](#) <2.4L Engine>).

**Post-installation Operation**

- Generator and Others Belt Installation (Refer to GROUP 11A – Crankshaft Pulley [P.11A-22](#) <2.0L Engine>, GROUP 11C – Crankshaft Pulley [P.11C-19](#) <2.4L Engine>).
- Radiator Condenser Tank Installation (Refer to GROUP 14 – Radiator [P.14-50](#) <2.0L Engine> or [P.14-53](#) <2.4L Engine>).
- Engine Upper Cover Installation (Refer to GROUP 11C – Camshaft [P.11C-24](#) <2.4L Engine>).
- Generator and Drive Belt Tension Check (Refer to GROUP 11A – On-vehicle Service – Drive Belt Tension Check [P.11A-9](#) <2.0L Engine>, GROUP 11C – On-vehicle Service – Drive Belt Tension Check [P.11C-8](#) <2.4L Engine>).
- Power Steering Fluid Supplying and Bleeding (Refer to [P.37-26](#)).

&lt;2.0L Engine&gt;

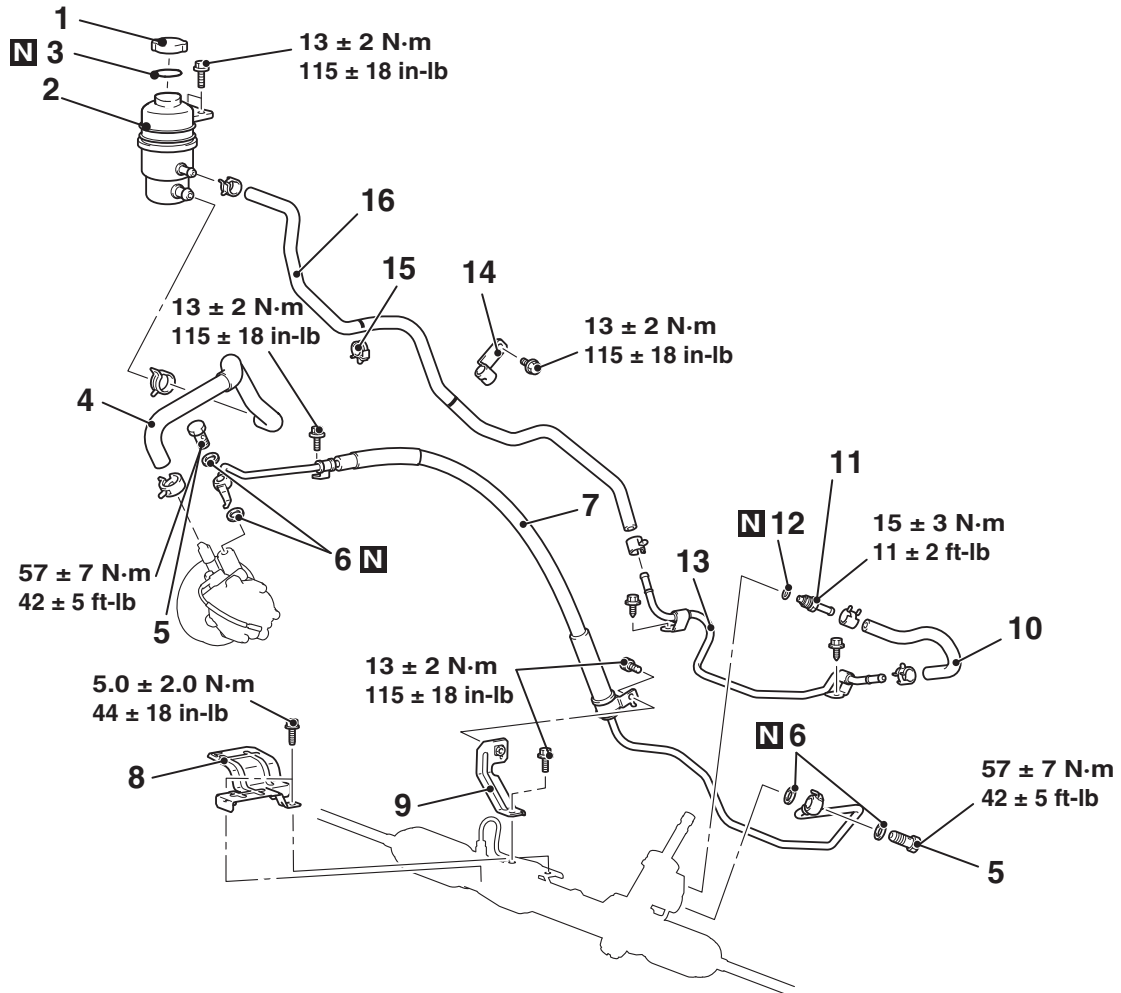

AC802970 AC

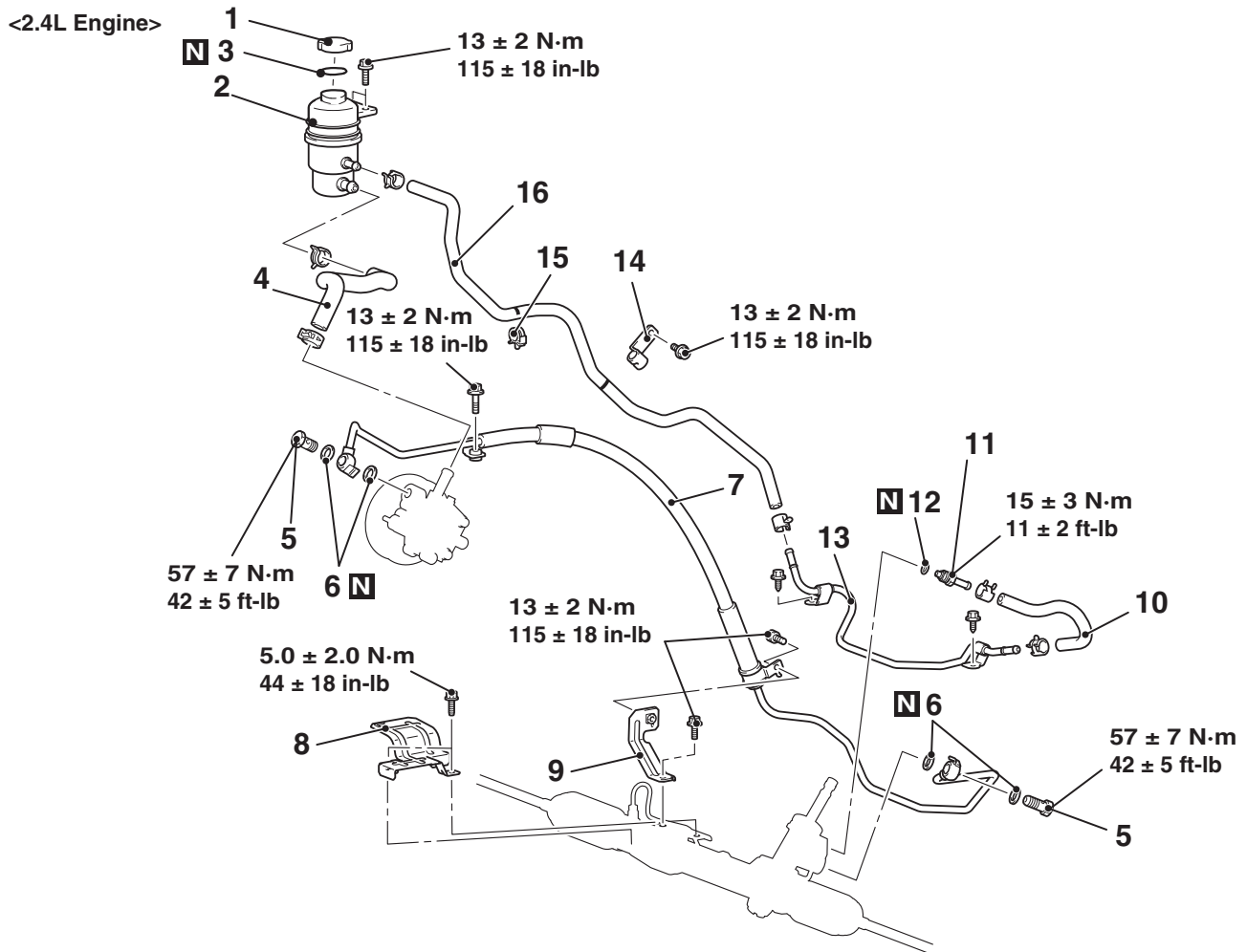

AC702686 AQ

**Removal steps**

1. Cap
2. Oil reservoir
3. O-ring
- >>C<< 4. Suction hose
5. Eye bolt
- >>B<< 6. Gasket
7. Pressure hose assembly
8. Heat protector

**Removal steps (Continued)**

9. Pressure hose bracket
10. Return hose
11. Return tube assembly
12. O-ring
13. Return tube
- >>A<< 14. Hose clamp
- >>A<< 15. Clip
- >>A<< 16. Return hose

## INSTALLATION SERVICE POINTS

>>A<< RETURN HOSE/ CLIP/ HOSE CLAMP  
INSTALLATION

1. Align the marking as shown in the figure and connect the return hose.

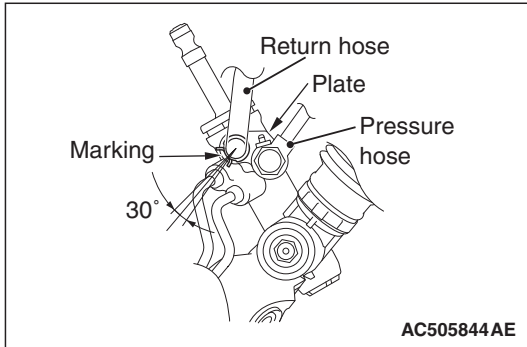

2. Align the return hose marking within the area shown in the figure and connect the return hose.

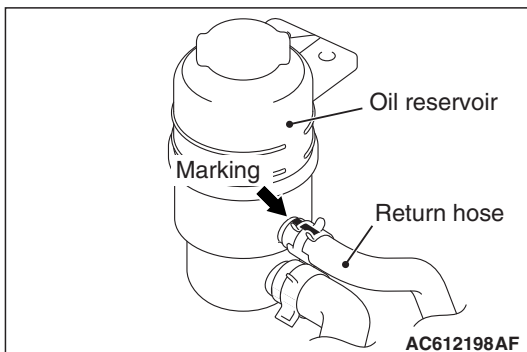

3. Using clip and hose clamp align the return hose marking within the area shown in the figure and connect the return hose.

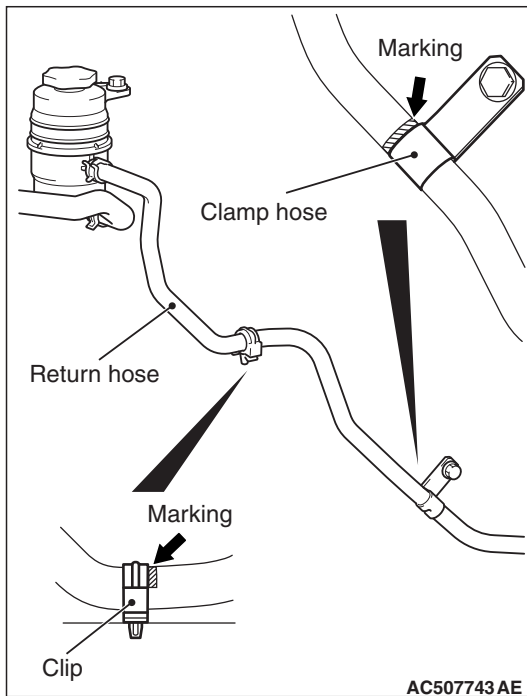



### >>B<< PRESSURE HOSE ASSEMBLY INSTALLATION

Align the pressure hose plate as shown in the figure and connect pressure hose assembly.

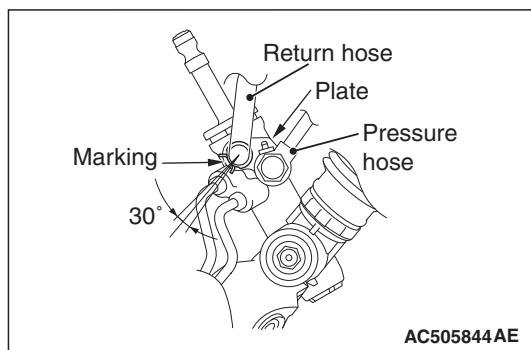

### >>C<< SUCTION HOSE INSTALLATION

1. Align the oil reservoir side suction hose marking within the area shown in the figure and connect the suction hose.

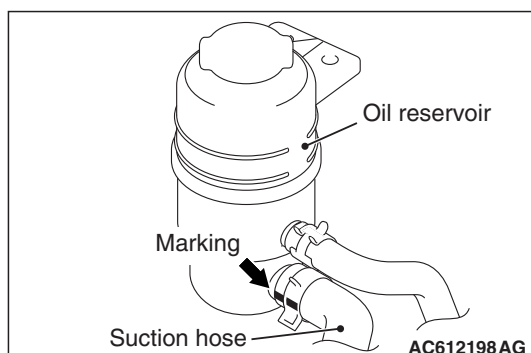

2. Align the oil pump side suction hose marking within the area shown in the figure and connect the suction hose.

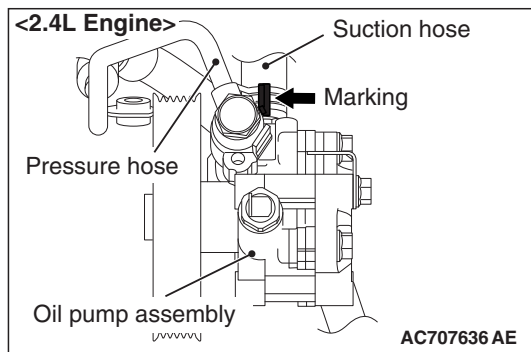
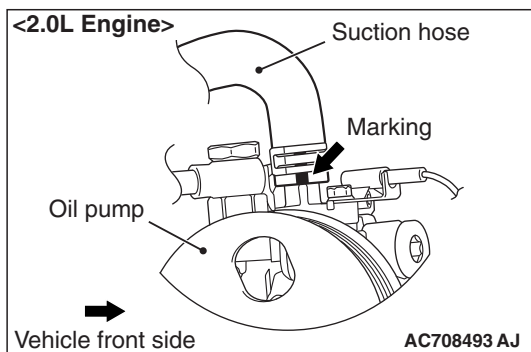

---

## NOTES