GROUP 21B

CLUTCH OVERHAUL

CONTENTS

SPECIFICATIONS	21B-2	CLUTCH	21B-3
GENERAL SPECIFICATIONS	21B-2	REMOVAL AND INSTALLATION	21B-3
SERVICE SPECIFICATIONS	21B-2	CLUTCH INSPECTION	21B-5
FASTENER TIGHTENING SPECIFICATIONS	21B-2		
LUBRICANTS	21B-2		

SPECIFICATIONS**GENERAL SPECIFICATIONS**

M1212000201141

Item	Specification
Clutch operating method	Hydraulic type
Clutch disc type	Single dry disc type
Clutch disc size OD x ID mm (in)	230 x 155 (9.1 x 6.1)
Clutch cover type	Diaphragm spring type
Clutch cover setting load N (lb)	4320 ± 350 (971.2 ± 78.7)

SERVICE SPECIFICATIONS

M1212000300673

Item	Limit
Diaphragm spring end height difference mm (in)	0.5 (0.019)
Clutch disc facing rivet sink mm (in)	0.8 (0.03)

FASTENER TIGHTENING SPECIFICATIONS

M1212001800938

Item	Specification
Clutch cover mounting bolt	27 ± 1 N·m (19.9 ± 0.7 ft-lb)
Concentric slave cylinder mounting bolt	10 ± 2 N·m (89 ± 17 in-lb)
Clutch fluid line bracket mounting bolt	50 ± 5 N·m (37 ± 3 ft-lb)

LUBRICANTS

M1212000400506

Item	Specified lubricant
Clutch fluid	Brake Fluid DOT 3 or DOT 4
Clutch disc splines	Mitsubishi Part No. 0101011 or equivalent

CLUTCH

REMOVAL AND INSTALLATION

M1212001001195

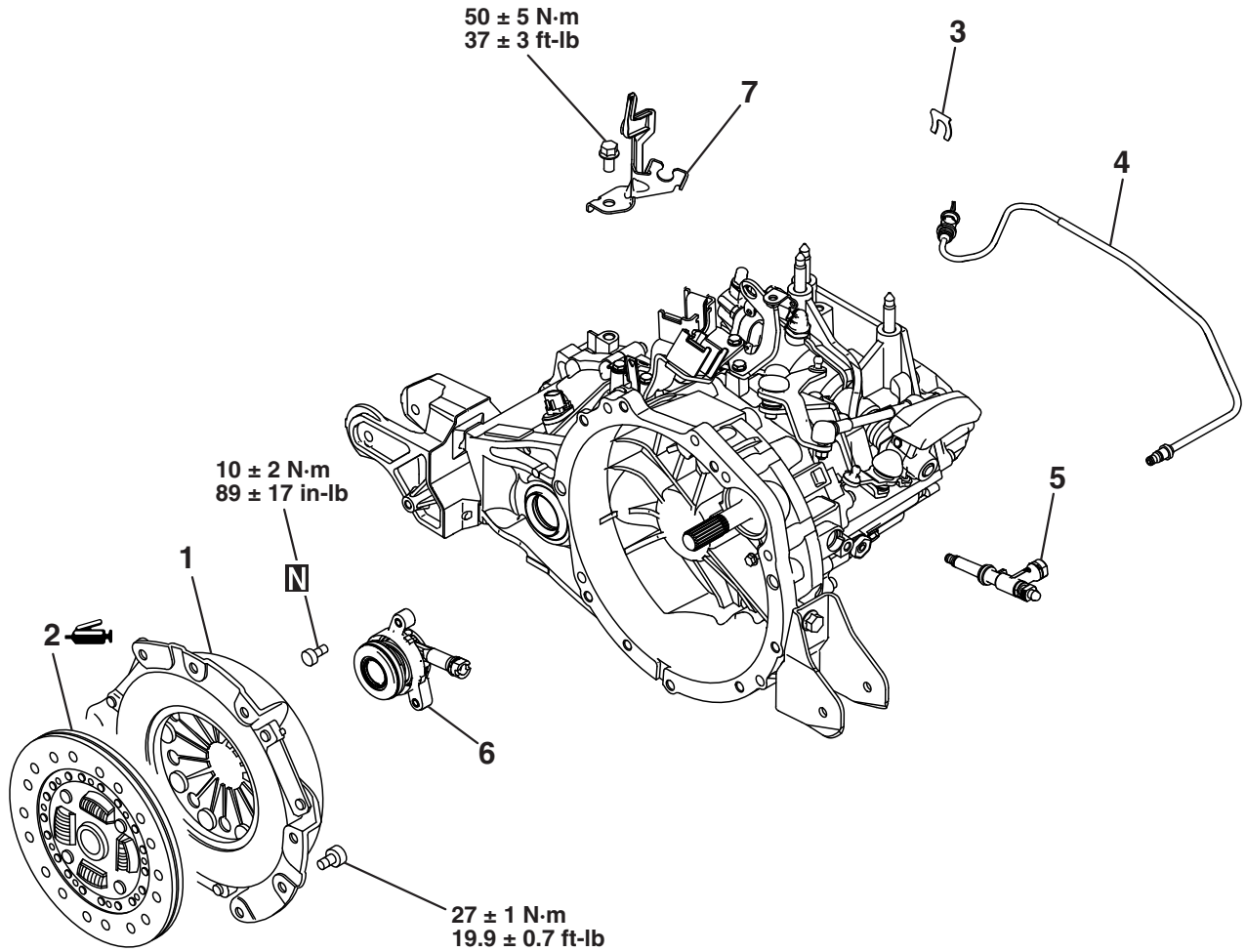

AK702178AF

Removal steps

- >>B<< 1. Clutch cover
- >>B<< 2. Clutch disc
- 3. Hose clip
- 4. Clutch tube

Removal steps (Continued)

- >>A<< 5. Concentric slave cylinder adapter
- >>A<< 6. Concentric slave cylinder
- 7. Clutch fluid line bracket

INSTALLATION SERVICE POINTS

>>A<< CONCENTRIC SLAVE CYLINDER/CONCENTRIC SLAVE CYLINDER ADAPTER INSTALLATION

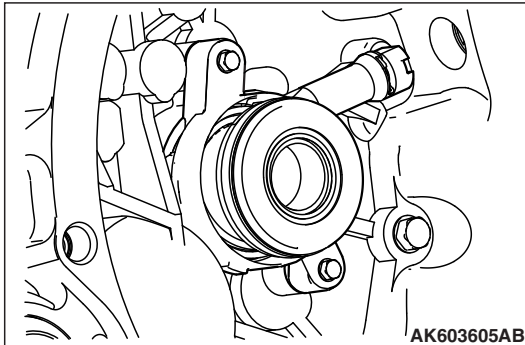

1. After setting the concentric slave cylinder to the transaxle case, tighten the flange bolt temporarily.

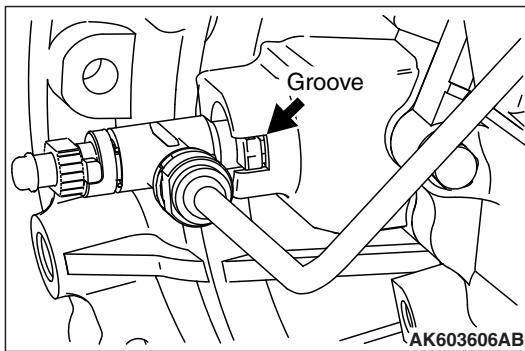

2. Assemble the concentric slave cylinder adapter with the concentric slave cylinder.

NOTE: Fit into the groove of the transaxle case.

3. Tighten the flange bolt to the specified torque.
Tightening torque: 10 ± 2 N·m (89 ± 17 in-lb)

>>B<< CLUTCH SET INSTALLATION

1. Apply Mitsubishi grease to the clutch disc splines and rub it into the splines with a brush.

Specified grease: Mitsubishi Part No. 0101011 or equivalent

2. Use the general service tool to position the clutch disc on the flywheel.
3. Install the clutch cover onto the flywheel.

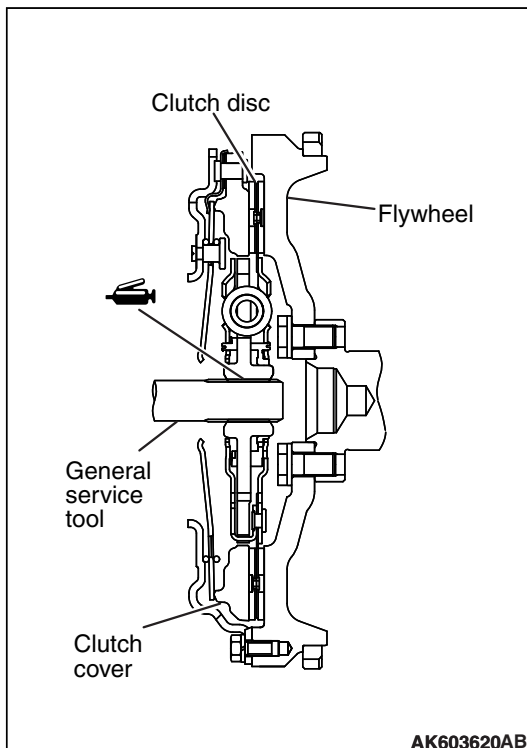

CLUTCH INSPECTION

M1212001100661

CLUTCH COVER

1. Check the diaphragm spring end for wear and uneven height. Replace if wear is evident or height difference exceeds the limit.

Limit: 0.5 mm (0.019 inch)

2. Check the pressure plate surface for wear, cracks and discoloration.
3. Check the rivets of the strap plate for looseness. If loose, replace the clutch set.

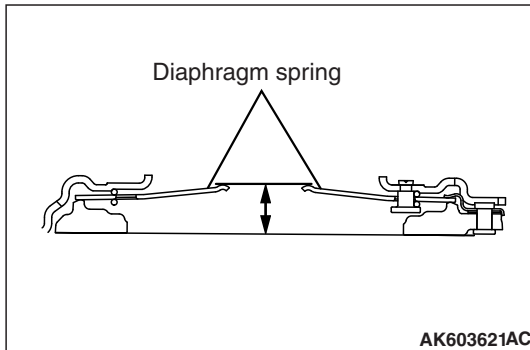

CLUTCH DISC

⚠ CAUTION

Don't clean the clutch disc in a cleaning solvent.

1. Check the facing for loose rivets, uneven contact, evidence of seizure, or deposited oils and greases. If defective, replace the clutch disc.

NOTE: If contaminated with grease or oil, determine the source of the contaminant and repair it.

2. Measure the rivet sink. Replace the clutch disc if it is below the limit.

Limit: 0.8 mm (0.03 inch)

3. Place the clutch disc on the input shaft and check for sliding condition and play in the rotating direction. If poor sliding condition is evident, clean, reassemble, and recheck. If excessive play is evident, replace the clutch disc and/or input shaft.

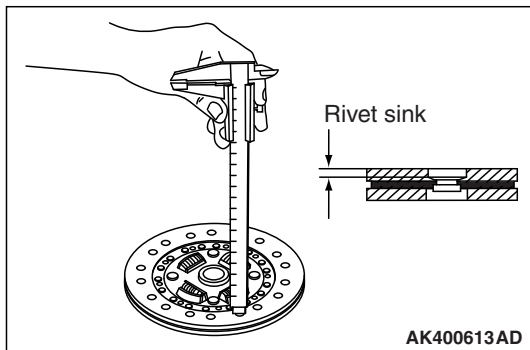

CONCENTRIC SLAVE CYLINDER ADAPTER

1. Check the O-ring for damage and deformation. If the O-ring is damage or deformed, replace the concentric slave cylinder adapter.
2. Check the surface that touches the concentric slave cylinder for contamination. If contaminated, clean the surface the specified clutch fluid.

Specified fluid: Brake Fluid DOT 3 or DOT 4

3. Make sure there are no deformed and/or missing clips.

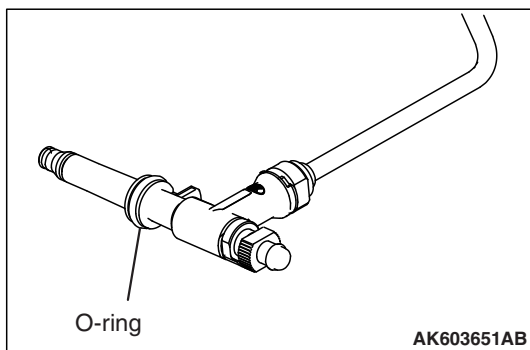

NOTES