

## GROUP 22B

# MANUAL TRANSAXLE OVERHAUL

## CONTENTS

<b>GENERAL SPECIFICATIONS</b> .....	<b>22B-2</b>	<b>INPUT SHAFT</b> .....	<b>22B-24</b>
<b>SERVICE SPECIFICATIONS</b> .....	<b>22B-2</b>	DISASSEMBLY AND ASSEMBLY .....	22B-24
<b>ADJUSTING SNAP RINGS AND SPACERS</b> .....	<b>22B-3</b>	<b>OUTPUT SHAFT</b> .....	<b>22B-29</b>
<b>FASTENER TIGHTENING SPECIFICATIONS</b> .....	<b>22B-4</b>	DISASSEMBLY AND ASSEMBLY .....	22B-29
<b>SEALANTS AND ADHESIVES</b> .....	<b>22B-5</b>	<b>SELECT LEVER</b> .....	<b>22B-35</b>
<b>LUBRICANTS</b> .....	<b>22B-5</b>	DISASSEMBLY AND ASSEMBLY .....	22B-35
<b>SPECIAL TOOLS</b> .....	<b>22B-6</b>	<b>BELLCRANK</b> .....	<b>22B-37</b>
<b>TRANSAXLE</b> .....	<b>22B-11</b>	BELLCRANK DISASSEMBLY AND ASSEMBLY .....	22B-37
DISASSEMBLY AND ASSEMBLY .....	22B-11	<b>CLUTCH HOUSING</b> .....	<b>22B-39</b>
INSPECTION .....	22B-24	DISASSEMBLY AND ASSEMBLY .....	22B-39
		<b>TRANSAXLE CASE</b> .....	<b>22B-44</b>
		DISASSEMBLY AND ASSEMBLY .....	22B-44
		<b>DIFFERENTIAL</b> .....	<b>22B-48</b>
		DISASSEMBLY AND ASSEMBLY .....	22B-48

**GENERAL SPECIFICATIONS**

M1222000201283

Item		Specification
Model		F5MBB-1-CBY
Applicable engine		4B12
Type		5-speed transaxle floor shift
Gear ratio	1st	3.538
	2nd	1.913
	3rd	1.333
	4th	0.972
	5th	0.775
	Reverse	3.538
Final reduction ratio		4.235

**SERVICE SPECIFICATIONS**

M1222000300878

Item	Standard value
Rotational starting torque of differential case N· m (in-lb)	0.8 –1.6 (7.08 –14.16)
Output shaft bearing preload N· m (in-lb)	0.8 –1.6 (7.08 –14.16)
Input shaft synchronizer hub No.3 thrust crevice mm (in.)	0 –0.1 (0 –0.004)
Input shaft synchronizer hub No.2 thrust crevice mm (in.)	0 –0.1 (0 –0.004)
Input shaft radial ball bearing thrust crevice mm (in.)	0 –0.1 (0 –0.004)

## ADJUSTING SNAP RINGS AND SPACERS

M1222012000614

### Adjustment shims (for differential side LH tapered roller bearing preload adjustment)

Thickness mm (in)	Thickness mm (in)
1.99 –2.01 (0.0783 –0.0791)	2.44 –2.46 (0.0961 –0.0969)
2.04 –2.06 (0.0803 –0.0811)	2.49 –2.51 (0.0980 –0.0988)
2.09 –2.11 (0.0823 –0.0831)	2.54 –2.56 (0.1000 –0.1008)
2.14 –2.16 (0.0843 –0.0850)	2.59 –2.61 (0.1020 –0.1028)
2.19 –2.21 (0.0862 –0.0870)	2.64 –2.66 (0.1039 –0.1047)
2.24 –2.26 (0.0882 –0.0890)	2.69 –2.71 (0.1059 –0.1067)
2.29 –2.31 (0.0902 –0.0909)	2.74 –2.76 (0.1079 –0.1087)
2.34 –2.36 (0.0921 –0.0929)	2.79 –2.81 (0.1098 –0.1106)
2.39 –2.41 (0.0941 –0.0949)	2.84 –2.86 (0.1118 –0.1126)

### Adjustment shims (for output shaft bearing preload adjustment)

Thickness mm (in)	Thickness mm (in)
1.29 –1.31 (0.0508 –0.0516)	1.94 –1.96 (0.0764 –0.0772)
1.34 –1.36 (0.0528 –0.0535)	1.99 –2.01 (0.0783 –0.0791)
1.39 –1.41 (0.0547 –0.0555)	2.04 –2.06 (0.0803 –0.0811)
1.44 –1.46 (0.0567 –0.0575)	2.09 –2.11 (0.0823 –0.0831)
1.49 –1.51 (0.0587 –0.0594)	2.14 –2.16 (0.0843 –0.0850)
1.54 –1.56 (0.0606 –0.0614)	2.19 –2.21 (0.0862 –0.0870)
1.59 –1.61 (0.0626 –0.0634)	2.24 –2.26 (0.0882 –0.0890)
1.64 –1.66 (0.0646 –0.0654)	2.29 –2.31 (0.0902 –0.0909)
1.69 –1.71 (0.0665 –0.0673)	2.34 –2.36 (0.0921 –0.0929)
1.74 –1.76 (0.0685 –0.0693)	2.39 –2.41 (0.0941 –0.0949)
1.79 –1.81 (0.0705 –0.0713)	2.44 –2.46 (0.0961 –0.0969)
1.84 –1.86 (0.0724 –0.0732)	2.49 –2.51 (0.0980 –0.0988)
1.89 –1.91 (0.0744 –0.0752)	

### Shaft snap rings (for input shaft synchronizer hub No.3 bushing end play adjustment)

Thickness mm (in)	Thickness mm (in)
1.75 –1.80 (0.0689 –0.0709)	2.00 –2.05 (0.0787 –0.0807)
1.80 –1.85 (0.0709 –0.0728)	2.05 –2.10 (0.0807 –0.0827)
1.85 –1.90 (0.0728 –0.0748)	2.10 –2.15 (0.0827 –0.0846)
1.90 –1.95 (0.0748 –0.0768)	2.15 –2.20 (0.0846 –0.0866)
1.95 –2.00 (0.0768 –0.0787)	

**FASTENER TIGHTENING SPECIFICATIONS**

M1222012101108

Item	Specification
<b>Clutch housing case assembly</b>	
Roll stopper bracket	90 ± 10 N· m (66 ± 7 ft-lb)
Vehicle speed sensor	10 ± 2 N· m (89 ± 17 in-lb)
Wiring harness clamp bracket	17.0 ± 6.8 N· m (13 ± 4 ft-lb)
Transaxle case hanger No.1	17.0 ± 6.8 N· m (13 ± 4 ft-lb)
Reverse shift arm bracket assembly	17.0 ± 5.1 N· m (13 ± 3 ft-lb)
Gear shift fork assembly No.2	24.0 ± 4.8 N· m (18 ± 2 ft-lb)
Gear shift head No.1	24.0 ± 4.8 N· m (18 ± 2 ft-lb)
Gear shift fork assembly No.1	24.0 ± 4.8 N· m (18 ± 2 ft-lb)
Transaxle case receiver	7.0 ± 2.8 N· m (62 ± 24 in-lb)
<b>Transaxle case assembly</b>	
Backup light switch	40 ± 16 N· m (30 ± 11 ft-lb)
Lock ball assembly	29.0 ± 8.7 N· m (21 ± 5 ft-lb)
Backup light switch wiring harness clamp	7.5 ± 2.3 N· m (66 ± 20 in-lb)
Control cable bracket	17.0 ± 6.8 N· m (13 ± 4 ft-lb)
Lever lock pin mounting nut	11.8 ± 3.5 N· m (106 ± 26 in-lb)
Control shift lever connecting nut	11.8 ± 3.5 N· m (106 ± 26 in-lb)
Selecting bell crank assembly and control bell crank dust cover mounting bolt	24.5 ± 9.8 N· m (18 ± 6 ft-lb)
Control shaft cover	20 ± 8 N· m (15 ± 5 ft-lb)
Clutch tube bracket	50 ± 5 N· m (37 ± 3 ft-lb)
Transaxle case cover sub assembly mounting bolt	29.0 ± 8.7 N· m (21 ± 5 ft-lb)
Gear shift fork assembly No.3	24.0 ± 4.8 N· m (18 ± 2 ft-lb)
5th drive gear mounting nut	123 ± 36.9 N· m (91 ± 26 ft-lb)
Rear bearing retainer	42.0 ± 8.4 N· m (31 ± 5 ft-lb)
Reverse idler shaft mounting bolt	30 ± 9 N· m (22 ± 6 ft-lb)
Clutch housing case mounting bolt	29.0 ± 5.8 N· m (21 ± 3 ft-lb)
Oil receiver pipe	17.0 ± 6.8 N· m (13 ± 4 ft-lb)
With head straight screw plug	13.0 ± 5.2 N· m (115 ± 44 in-lb)
Select shaft lever nut	12 ± 3 N· m (106 ± 26 in-lb)
Select lever shaft nut	12 ± 3 N· m (106 ± 26 in-lb)
<b>Differential case</b>	
Ring gear	106 ± 6.4 N· m (78 ± 4 ft-lb)

## SEALANTS AND ADHESIVES

M1222000500957

Item	Specified sealant
Mating face for transaxle case and clutch housing	Mitsubishi Part No. MD974421 or equivalent
Mating face for transaxle case and transaxle case cover sub assembly	

### FORM-IN-PLACE GASKET (FIPG)

This transaxle has several areas where the form-in-place gasket (FIPG) is used for sealing. To ensure that the FIPG fully serves its purpose, it is necessary to observe some precautions when applying it. Bead size, continuity and location are of paramount importance.

Too thin a bead could cause leaks. Too thick a bead, on the other hand, could be squeezed out of location, causing blocking or narrowing of fluid passages. To prevent leaks or blocking of passages, therefore, it is absolutely necessary to apply the FIPG evenly without a break, while observing the correct bead size. FIPG hardens as it reacts with the moisture in the atmospheric air, and it is usually used for sealing metallic flange areas.

#### CAUTION

When re-applying liquid gasket (FIPG), be sure that:

1. Residues of FIPG are cleared from all the ins and outs of parts;
2. Use Mitsubishi genuine parts cleaner (MZ100387) or equivalent to well degrease the FIPG-applied surface.
3. FIPG is correctly applied in accordance with FIPG Application.

### Disassembly

Parts sealed with a FIPG can be easily removed without need for the use of a special method. In some cases, however, the FIPG in joints may have to be broken by tapping parts with a mallet or similar tool.

### Surface Preparation

Thoroughly remove all substances deposited on the FIPG application surface, using a gasket scraper. Make sure that the FIPG application surfaces is flat and smooth. Also make sure that the surface is free from oils, greases and foreign substances. Do not fail to remove old FIPG that may remain in the fastener fitting holes.

### FIPG Application

Applied FIPG bead should be of the specified size and free of any break. FIPG can be wiped away unless it has completely hardened. Install the mating parts in position while the FIPG is still wet. Do not allow FIPG to spread beyond the sealing areas during installation. Avoid operating the transaxle or letting oils or water come in contact with the sealed area before a time sufficient for FIPG to harden (approximately one hour) has passed. FIPG application method may vary from location to location. Follow the instruction for each particular case described later in this manual.

## LUBRICANTS

M1222000400518

Item	Specified sealant
Gear oil	DiaQueen NEW MULTI GEAR OIL API classification GL-3, SAE 75W-80
Select lever oil seal	Mitsubishi Part No. 0101011 or equivalent
Oil seal	

## SPECIAL TOOLS

M122200600578

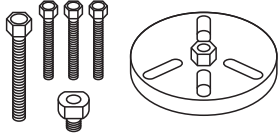
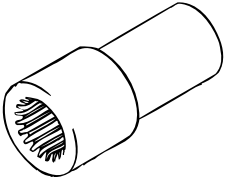
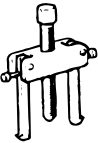
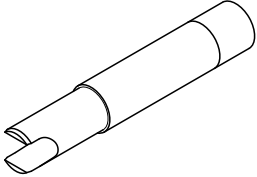
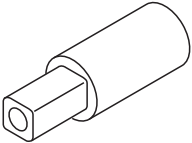
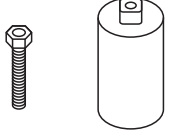
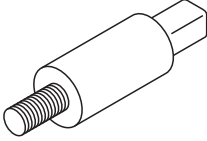

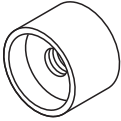
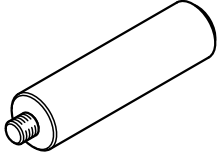
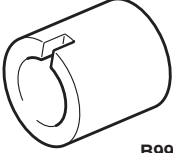
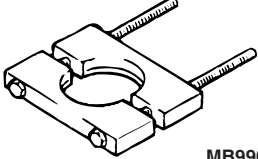
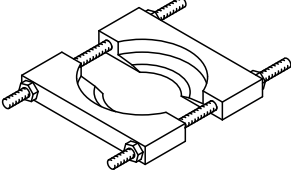
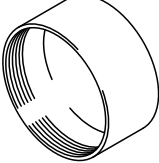
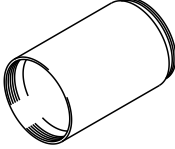
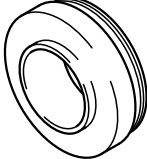
Tool	Tool number and name	Supersession	Application
	MB992221 Puler set	-	Remove of synchronizer hub No.3
	MD998802 Input shaft holder	-	Remove and installation of 5th drive gear mounting lock nut
 <p data-bbox="321 919 410 940">MB990801</p>	MB990801 Rear axle bearing outer race puller	General service tool	Remove of 5th drive gear removal
	MB992038 Preload socket	MB992038-01	<ul style="list-style-type: none"> <li>• Measurement of differential side bearing preload</li> <li>• Measurement of output shaft assembly bearing preload</li> </ul>
	MB992219 Output shaft adapter	-	Installation of 5th drive gear
	MB992216 Installer	-	<ul style="list-style-type: none"> <li>• Installation of 5th drive gear</li> <li>• Installation of synchronizer hub No.3</li> </ul>
	MB992220 Input shaft adapter	-	Installation of synchronizer hub No.3

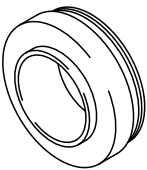
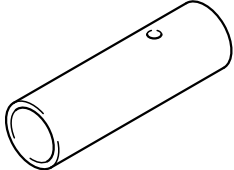
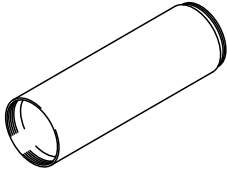
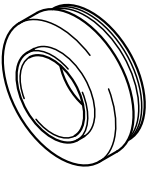
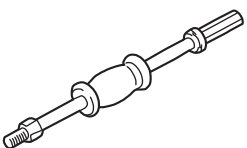
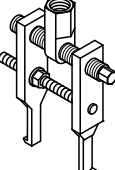
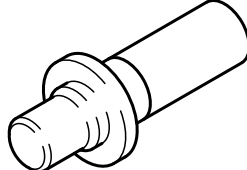
Tool	Tool number and name	Supersession	Application
	MB992212 Oil seal installer	–	Installation of oil seal
	MB992075 Handle	–	
 <p align="center">B992000</p>	MB992000 Crankshaft adapter	–	Installation of plug
 <p align="center">MB990560</p>	MB990560 Rear axle shaft bearing installer	–	Remove of input and output shaft cylindrical roller bearing
	MD998917 Bearing remover	General service tool or MD998348-01	<ul style="list-style-type: none"> <li>• Remove of each bearing</li> <li>• Remove of input and output shaft each gear</li> </ul>
	MD998812 Installer cap	General service tool or MIT304180-A	Use with installer and installer adapter
	MD998813 Installer-100	General service tool or MIT304180-A	Use with installer and installer adapter
	MD998818 Installer adapter	General service tool	Installation of input shaft cylindrical roller bearing

Tool	Tool number and name	Supersession	Application
	MD998820 Installer adapter	MD998820-01	<ul style="list-style-type: none"> <li>• Installation of synchronizer sleeve No.2 and synchronizer hub No.2</li> <li>• Installation of 4th gear sub-assembly and radial ball bearing</li> <li>• Installation of tapered roller bearing inner race</li> </ul>
	MD998368 Bearing installer	-	Remove of tapered roller bearing inner race
	MD998814 Installer 200	MIT304180-A	Use with installer cap and installer adapter
	MD998819 Installer adapter	General service tool	<ul style="list-style-type: none"> <li>• Install the synchronizer hub and reverse gear</li> <li>• Installation of 3rd drive gear</li> <li>• Installation of 4th drive gear</li> <li>• Installation of tapered roller bearing inner race</li> </ul>
 <p style="text-align: center; margin-top: 5px;">MB990211</p>	MB990211 Slide hammer	MB990211-01	Use with slide hammer puller
	MB992039 Slide hammer puller	MB992039-01	<ul style="list-style-type: none"> <li>• Remove of cylindrical roller bearing (outer race)</li> <li>• Remove of tapered roller bearing outer race</li> </ul>
	MD998200 Oil seal installer	-	Installation of oil seal

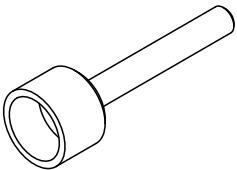
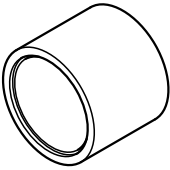
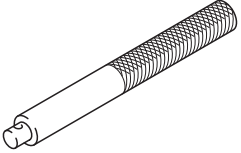
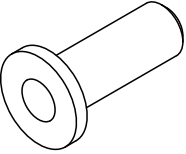
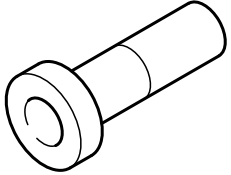
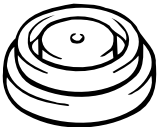
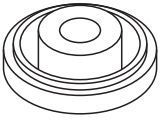
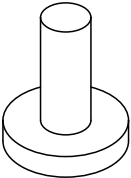

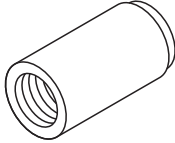
Tool	Tool number and name	Supersession	Application
	MD998550 Extension housing seal installer	-	Install the oil seal
	MB991445 Bush remover and installer base	MB991445-01	Installation of tapered roller bearing outer race
	MB990938 Installer bar	MB990938-01	Installation of tapered roller bearing outer race
	MB990699 Differential oil seal installer	-	Installation of tapered roller bearing outer race
	MD999547 Oil seal installer	-	Installation of cylindrical roller bearing outer race
 MB991015	MB991015 Knuckle oil seal installer	MB991015-01	Remove of tapered roller bearing outer race
	MB992210 Oil seal installer	-	Installation of oil seal
	MB991966 Bearing outer race installer	-	Installation of tapered roller bearing outer race

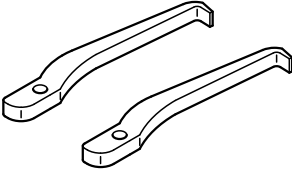
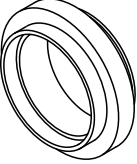
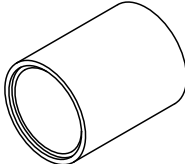
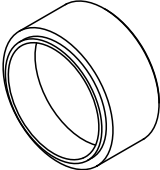
Tool	Tool number and name	Supersession	Application
	MB991395 Crankshaft front oil seal installer	–	<ul style="list-style-type: none"> <li>• Remove of tapered roller bearing inner race</li> <li>• Remove of speedometer drive gear</li> <li>• Remove of tapered roller bearing outer race</li> </ul>
 MB990810	MB990810 Side bearing puller	General service tool	Remove of tapered roller bearing outer race
	MD999566 Claw	–	Remove of tapered roller bearing outer race
	MB992150 Oil seal installer	–	Installation of tapered roller bearing outer race
	MB990891 Rear suspension bushing base	MB990891-01	Installation of speedometer drive gear
	MB992138 Bearing installer	–	Installation of tapered roller bearing outer race

# TRANSAXLE

## DISASSEMBLY AND ASSEMBLY

M1222016500150

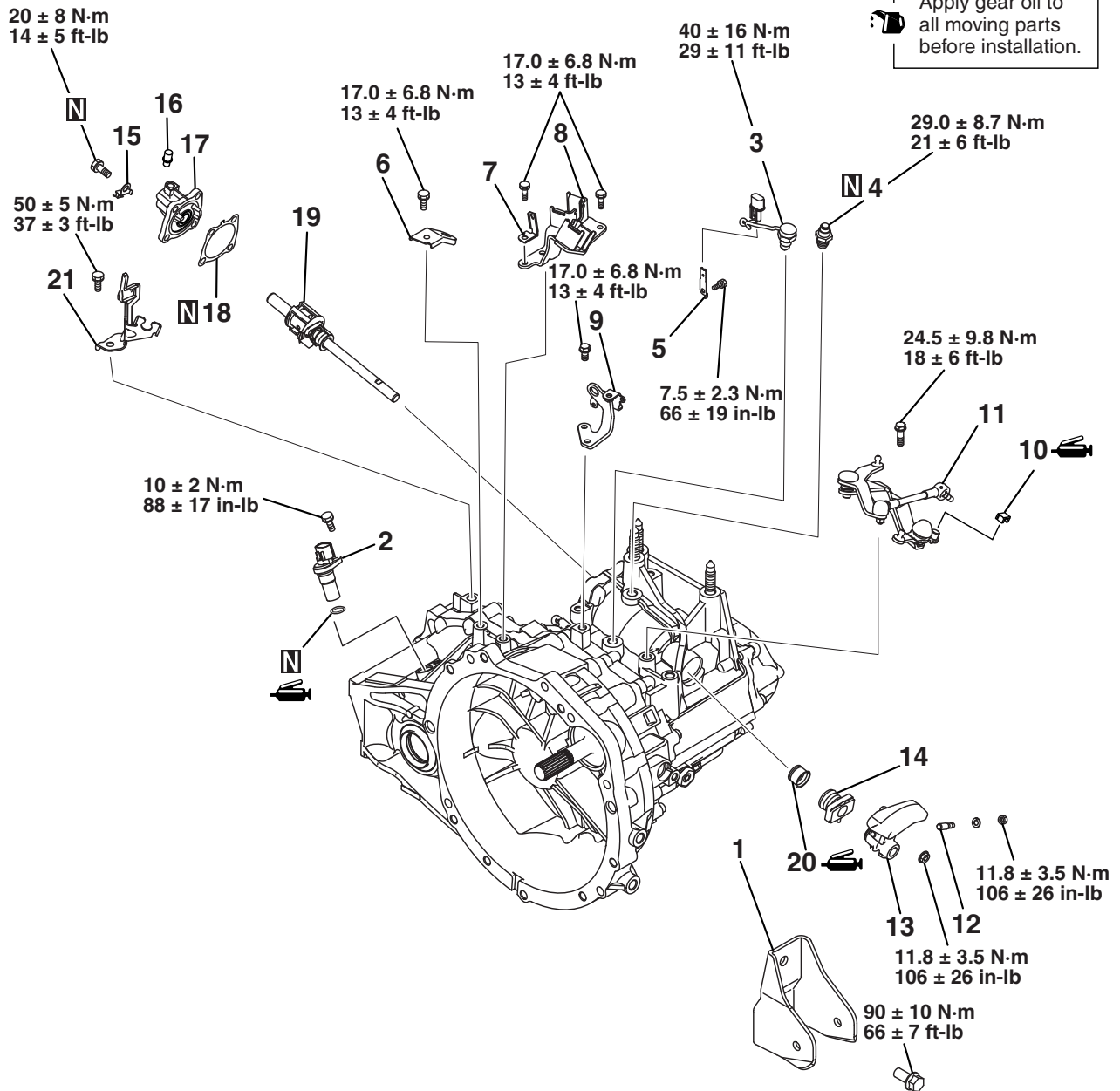

### Removal steps

1. Roll stopper bracket front
2. Vehicle speed sensor
3. Backup light switch assembly
4. Lock ball assembly
5. Backup light switch wiring harness clamp bracket
6. Wiring harness clamp bracket
7. Wiring harness clamp bracket
8. Transaxle case hanger No.1
9. Control cable bracket
10. Select lever shoe

<<A>>

### Removal steps (Continued)

11. Selecting bell crank assembly and control bell crank dust cover
12. Lever lock pin
13. Control shift lever
14. Dust boot
15. Clamp
- >>M<< 16. Plug
- >>L<< 17. Control shaft cover
- >>K<< 18. Control shift retainer gasket
19. Shift and select lever shaft
20. Oil seal
21. Clutch tube bracket

AK900023AC

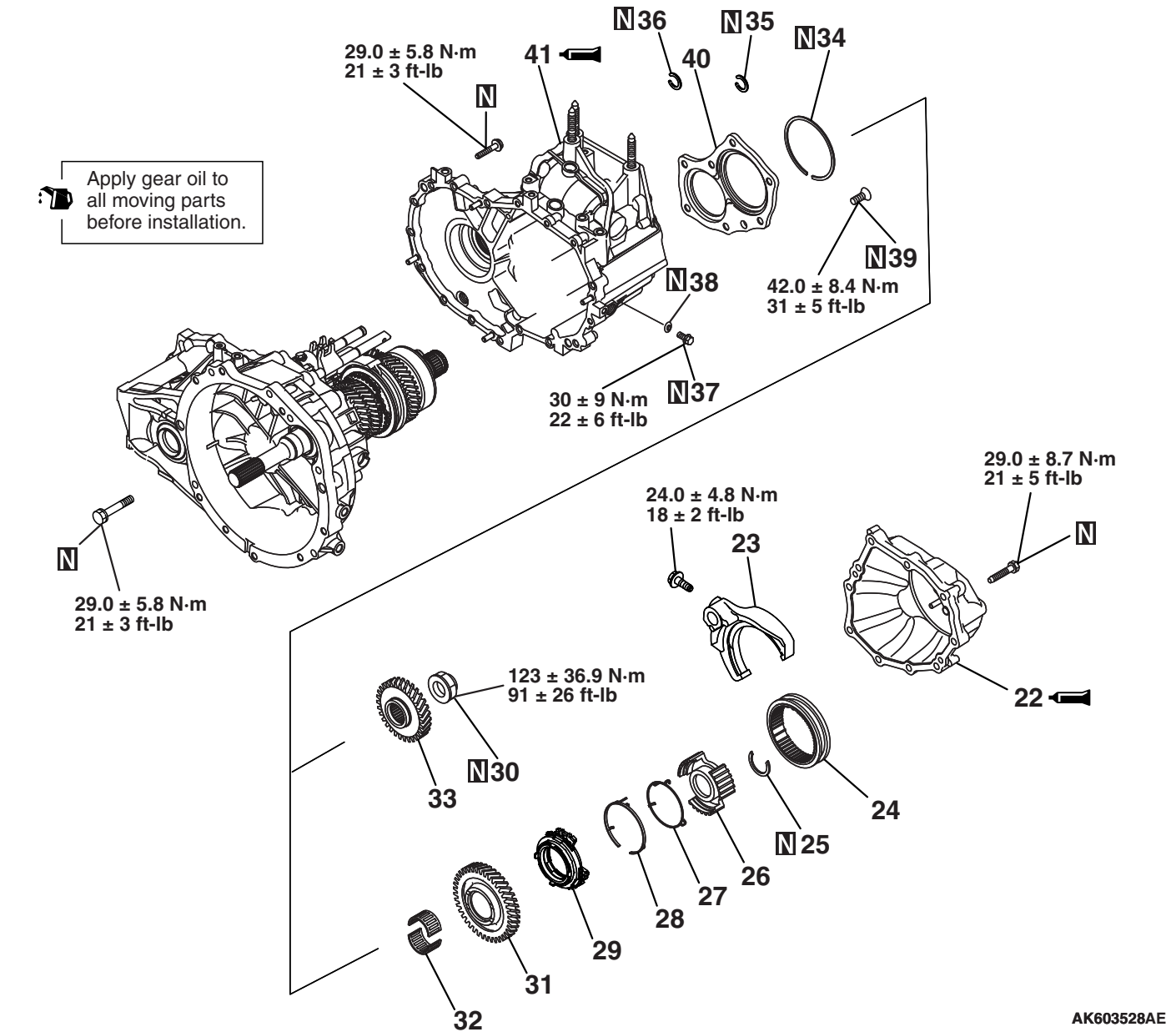

AK603528AE

**Removal steps**

- >>J<< 22. Transaxle case cover sub assembly
- 23. Gear shift fork assembly No.3
- >>I<< 24. Synchronizer sleeve No.3
- >>H<< 25. Shaft snap ring
- <<B>> >>G<< 26. Synchronizer hub No.3
- >>G<< 27. Synchromesh shifting key spring No.3 (A)
- >>G<< 28. Synchromesh shifting key spring No.3 (B)
- >>G<< 29. Synchronizer ring assembly
- <<C>> >>F<< 30. 5th drive gear mounting lock nut
- 31. 5th gear

**Removal steps (Continued)**

- 32. Needle roller bearing
- <<D>> >>E<< 33. 5th drive gear
- 34. Shaft snap ring
- 35. Shaft snap ring
- 36. Shaft snap ring
- 37. Reverse idler gear shaft mounting bolt
- 38. Gasket
- 39. Rear bearing retainer mounting bolt
- 40. Rear bearing retainer
- >>D<< 41. Transaxle case assembly

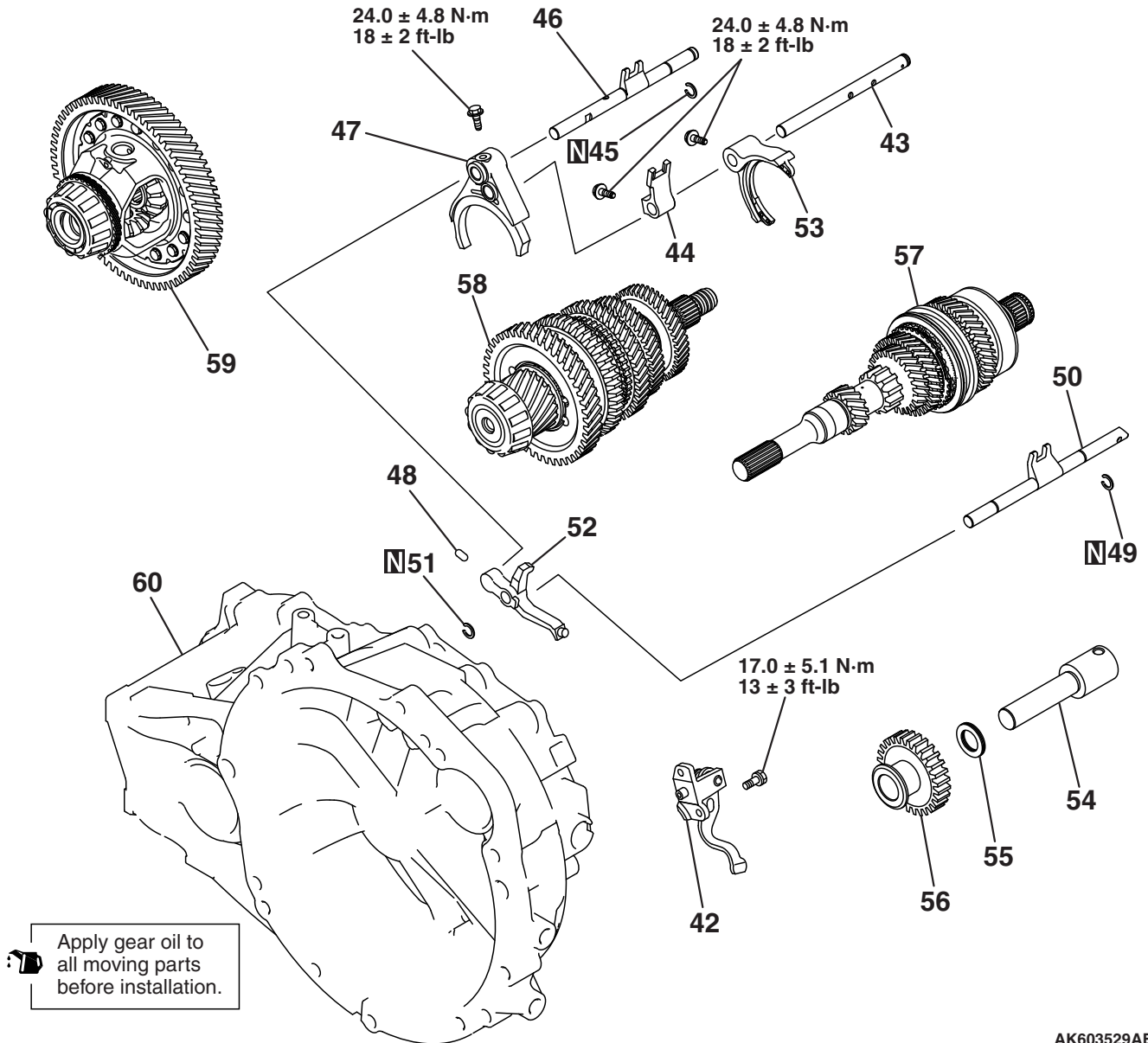

**Removal steps**

- >>C<< 42. Reverse shift arm bracket assembly
- 43. Gear shift fork shaft No.2
- 44. Gear shift head No.1
- 45. Shaft snap ring
- >>B<< 46. Gear shift fork shaft No.1
- >>B<< 47. Gear shift fork assembly No.1
- 48. Roller
- 49. Shaft snap ring
- 50. Gear shift fork shaft No.3
- 51. Shaft snap ring

**Removal steps (Continued)**

- 52. Reverse shift fork
- 53. Gear shift fork assembly No.2
- >>A<< 54. Reverse idler shaft
- >>A<< 55. Reverse idler thrust washer
- >>A<< 56. Reverse idler gear
- 57. Input shaft assembly
- 58. Output shaft assembly
- 59. Differential assembly
- 60. Clutch housing case assembly

**Required Special Tools:**

- MB992221: Puller set
- MD998802: Input shaft Holder
- MB990801: Rear axle bearing outer race puller
- MB992038: Preload socket
- MB992219: Output shaft adapter
- MB992216: Installer
- MB992220: Input shaft adapter
- MB992212: Oil seal installer
- MB992075: Handle
- MB992000: Crankshaft adapter

**DISASSEMBLY SERVICE POINTS****<<A>> SELECTING BELL CRANK ASSEMBLY  
AND CONTROL BELL CRANK DUST COVER  
REMOVAL**

Remove the fixing nuts shown, then separate the control shift lever from the selecting bell crank assembly and control bell crank dust cover.

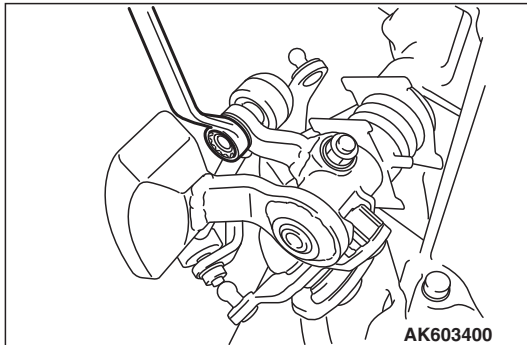
**<<B>> SYNCHRONIZER HUB NO.3 REMOVAL**

Using special tool MB992221, remove the synchronizer hub No.3.

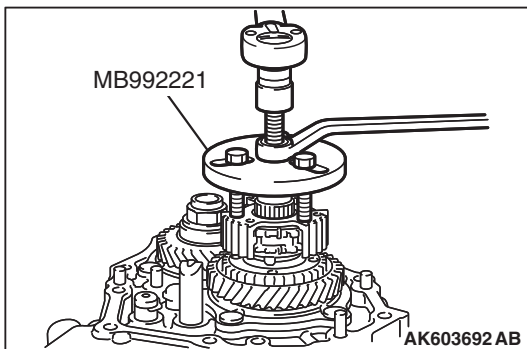
**<<C>> 5TH DRIVE GEAR MOUNTING LOCK NUT  
REMOVAL**

1. Using special tool MD998802, lock the input shaft.

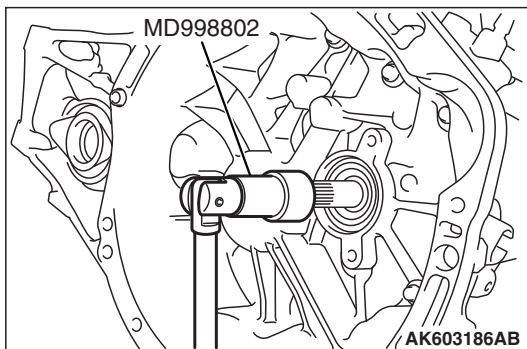

2. Remove the 5th drive gear mounting lock nut from output shaft assembly.

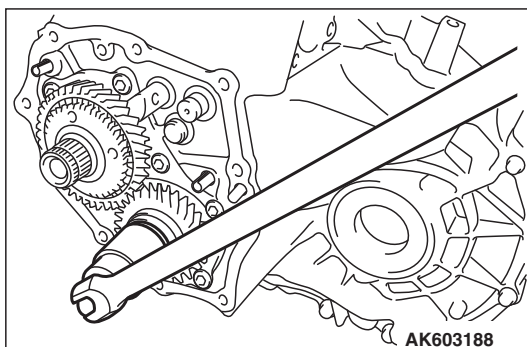

### <<D>> 5TH DRIVE GEAR REMOVAL

Using special tool MB990801, remove the 5th drive gear.

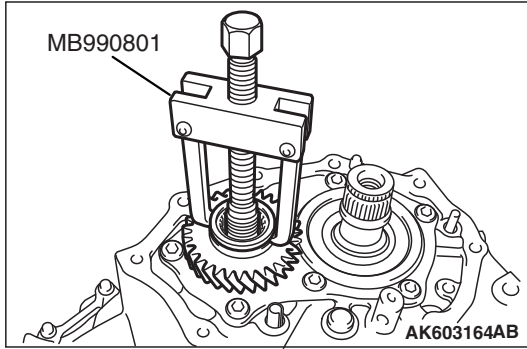

### ADJUSTMENT BEFORE ASSEMBLY

#### DIFFERENTIAL SIDE BEARING PRELOAD ADJUSTMENT

1. Set the differential assembly to the clutch housing case assembly.
2. Push and fit the tapered roller bearing outer race by hand.
3. To fit the tapered roller bearing outer race, rotate the differential assembly by hand about 10 times.

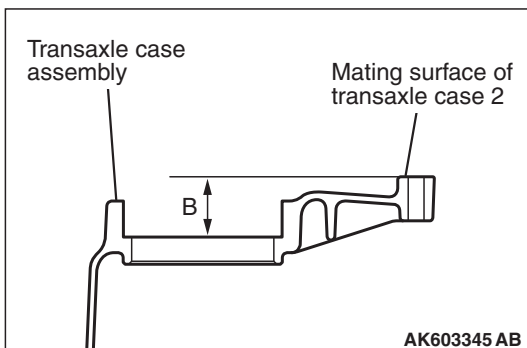
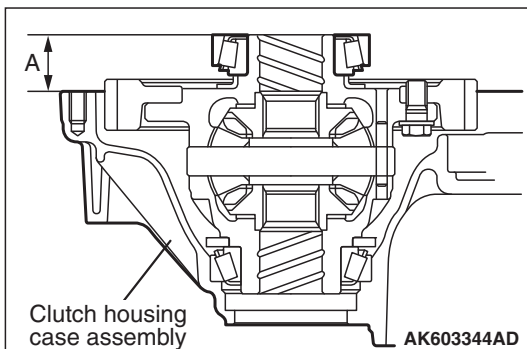
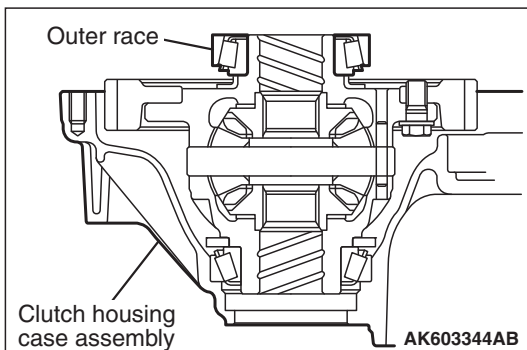

4. Put the clutch housing case assembly on the surface table and use a height gauge to measure the dimension "A" which is from the mating surface of the clutch housing case assembly to the end surface of the tapered roller bearing outer race.

5. Put the straight edge on the mating surface of the transaxle case assembly and measure the dimension "B" with a vernier caliper.
6. Select the shim whose dimension is the difference between "B" and "A."
7. Install the differential assembly to the clutch housing case assembly. Tighten the transaxle case bolts to the specified torque.

**Tightening torque: 29.0 ± 5.8 N·m (21 ± 3 ft-lb)**



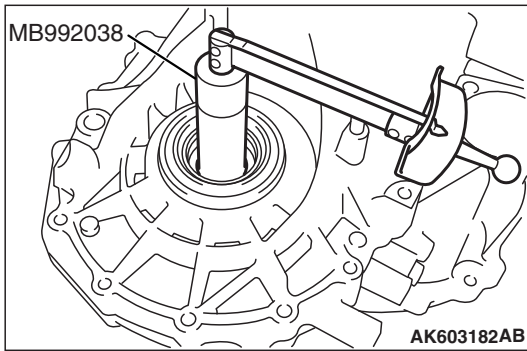

8. Using special tool MB992038, measure the rotational starting torque of differential case. When it is not within the standard range, reselect the shim.

**Standard value: 0.8 –1.6 N· m (7.08 –14.16 in-lb)**

### OUTPUT SHAFT ASSEMBLY BEARING PRELOAD ADJUSTMENT

1. Set the output shaft assembly to the clutch housing case assembly.
2. Push and fit the tapered roller bearing outer race by hand.
3. To fit the tapered roller bearing outer race, rotate the output shaft assembly by hand.

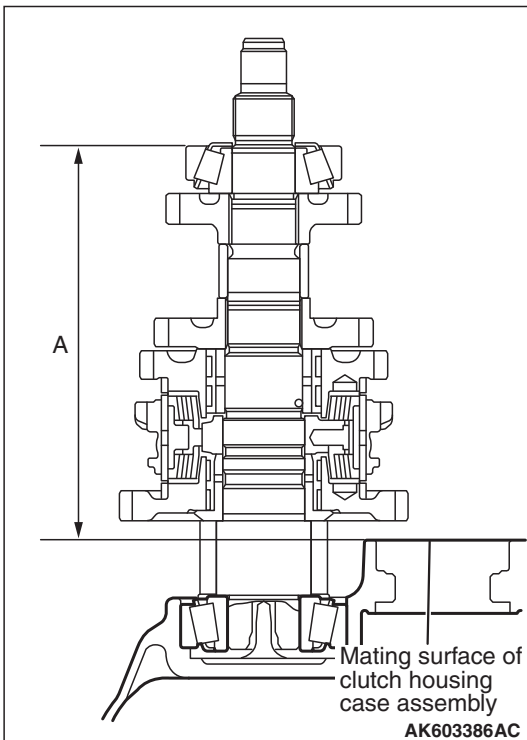
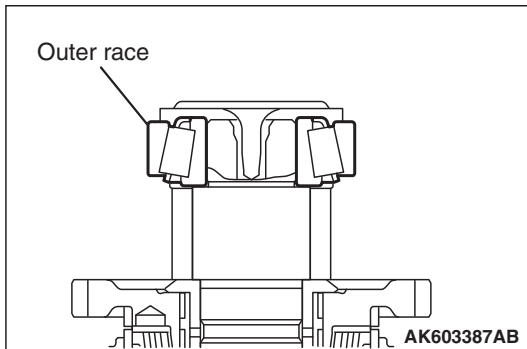

4. Put the clutch housing case assembly on the surface table and measure the dimension "A" which is from the mating surface of the clutch housing case assembly to the end surface of the bearing outer race, with a height gauge.



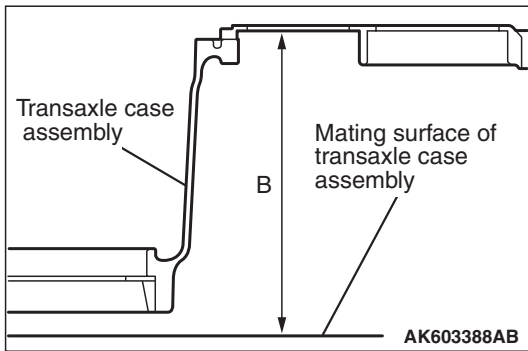

5. Put the straight edge on the mating surface of the transaxle case assembly and measure the dimension "B" with a vernier caliper.
6. Select the shim whose dimension is the difference between "B" and "A."
7. Install the output shaft assembly and differential assembly to the clutch housing case assembly. Tighten the transaxle case bolts to the specified torque.

**Tightening torque: 29.0 ± 5.8 N· m (21 ± 3 ft-lb)**

8. Place the selected shim, then install the output shaft assembly.
9. Install the rear bearing retainer to specified torque.

**Tightening torque: 42.0 ± 8.4 N· m (31 ± 5 ft-lb)**

10. Install the 5th gear mounting lock nut to measure rotational starting torque.

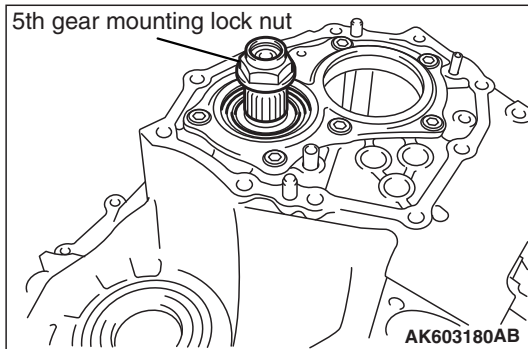

11. Measure the rotational starting torque of output shaft. When it is not within the standard range, reselect the shim.

**Standard value: 0.8 –1.6 N· m (7.08 –14.16 in-lb)**

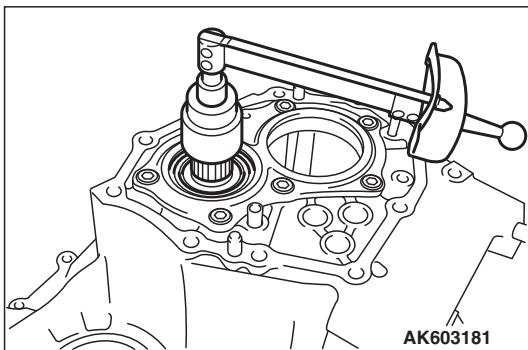

## ASSEMBLY SERVICE POINTS

### >>A<< REVERSE IDLER GEAR, REVERSE IDLER THRUST WASHER AND REVERSE IDLER SHAFT INSTALLATION

1. Install the reverse idler gear, reverse idler thrust washer and reverse idler shaft.
2. Before installing the transaxle case assembly, confirm that the reverse idler gear addition mark is positioned as show in the illustration.

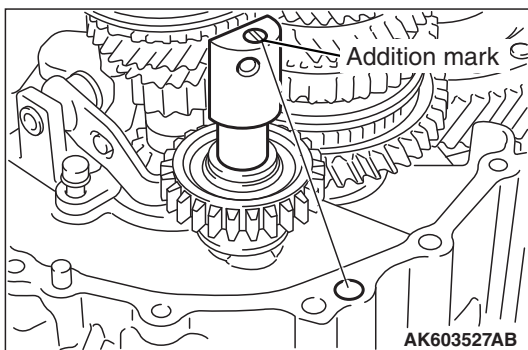

**>>B<< GEAR SHIFT FORK ASSEMBLY NO.1 AND  
GEAR SHIFT FORK SHAFT NO.1 INSTALLATION**

1. Fit the shaft snap ring onto the gear shaft fork shaft No. 1.
2. Bring up the notch in the gear shift fork shaft No. 3 to the reverse shift fork into neutral position, and move the roller in the reverse shift fork to the gear shift fork shaft No 3 side.

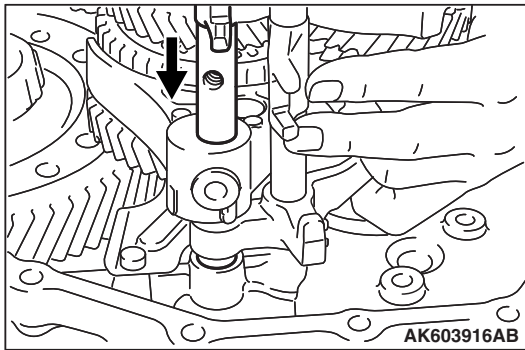
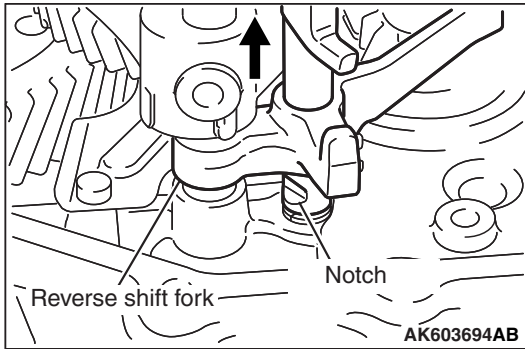

3. Pass the gear shift fork shaft No. 1 through the gear shift fork assembly No. 1 and reverse shift fork in that order, then install it to the clutch housing case assembly.

**>>C<< REVERSE SHIFT ARM BRACKET  
ASSEMBLY INSTALLATION**

Fit the arm tip of the reverse shift fork into the mating slot in the reverse shift arm bracket assembly.

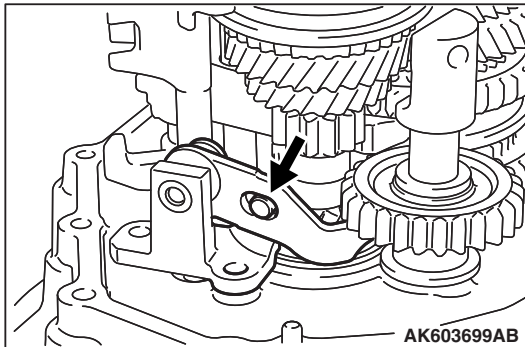
**>>D<< TRANSAXLE CASE ASSEMBLY  
INSTALLATION**

1. Completely degrease the FIPG-applied surface so that water and oil including the old sealant cannot adhere to the surface coated with the sealant.  
Never touch the degreased surface by hand.
2. Apply a 1.2 mm (0.05 inch) diameter bead of sealant as illustrated onto the transaxle case assembly.

**Specified sealant: Mitsubishi Part No. MD974421 or equivalent**

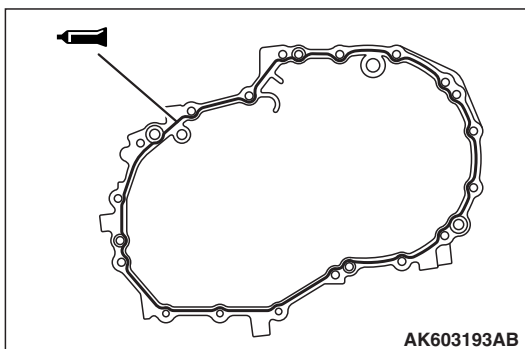

**>>E<< 5TH DRIVE GEAR INSTALLATION**

1. Install special tool MB992219 until it hits the end face of the output shaft.

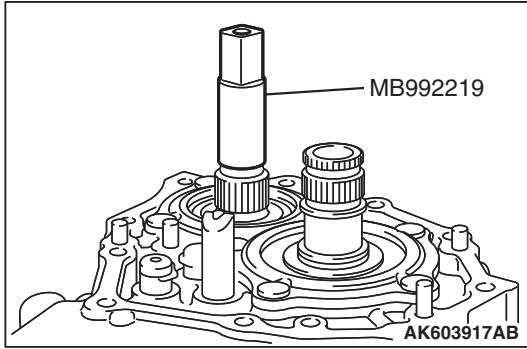

2. Install the 5th drive gear.

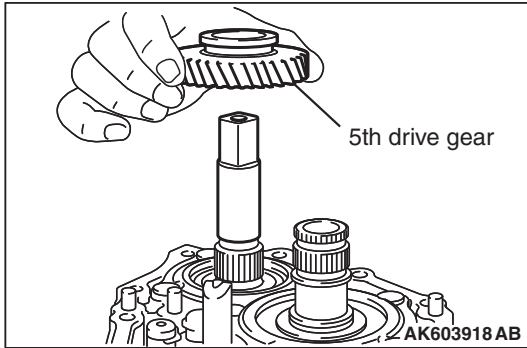

3. Set special tool MB992216 on top of the 5th drive gear.

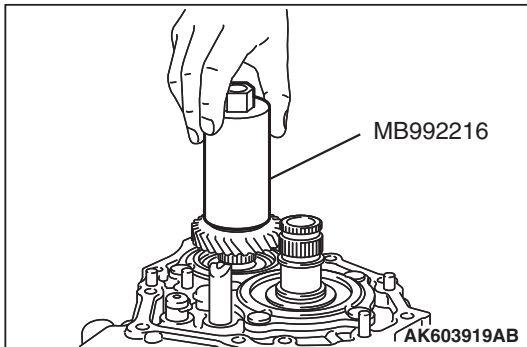

4. Install the center bolt that is included in the set of special tool MB992216 as shown.

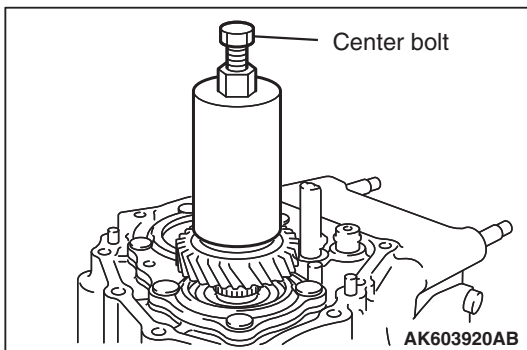

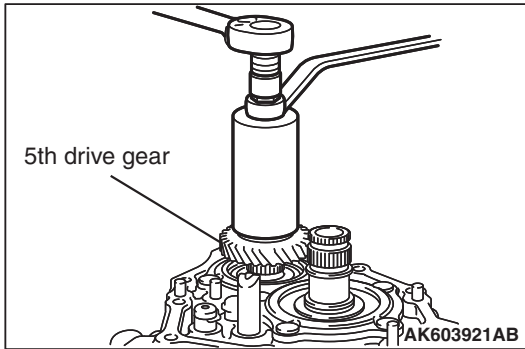

5. Press-fit the 5th drive gear as shown.

### >>F<< 5TH DRIVE GEAR MOUNTING LOCK NUT INSTALLATION

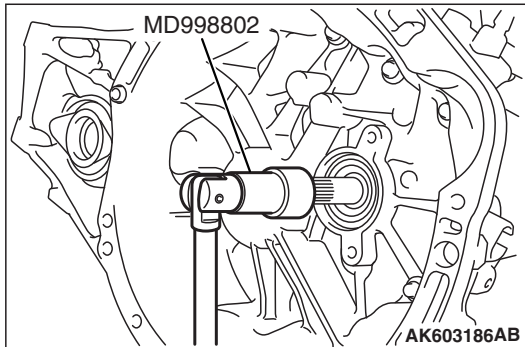

1. Using special tool MD998802, lock the input shaft.

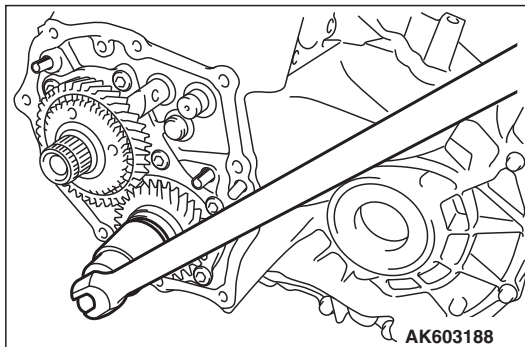

2. Install the 5th drive gear mounting lock nut from output shaft assembly.
3. Tighten the 5th drive gear mounting lock nut to the specified torque.

**Tightening torque: 123 ± 36.9 N·m (91 ± 26 ft-lb)**

4. Stake the 5th gear mounting lock nut.

### >>G<< SYNCHRONIZER RING ASSEMBLY / SYNCHROMESH SHIFTING KEY SPRING NO.3 (A) / SYNCHROMESH SHIFTING KEY SPRING NO.3 (B) AND SYNCHRONIZER HUB NO.3 INSTALLATION

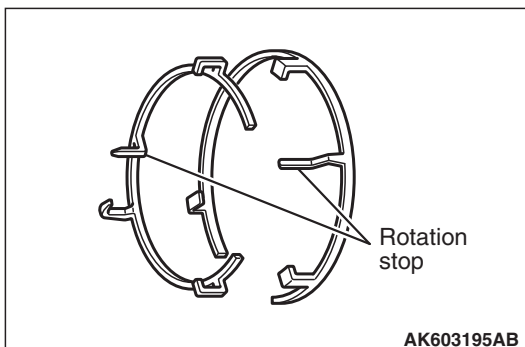

1. Install the synchromesh shifting key springs No. 3 onto the synchronizer ring assembly holding the claws and rotation stops of the key springs in the illustrated positions.

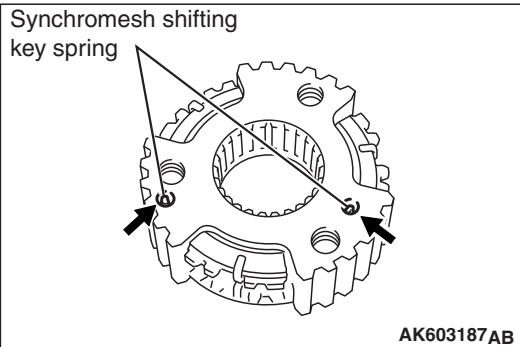

2. Make sure that the rotation stops of the synchronismesh shifting key springs No. 3 fit into the mating holes in the synchronizer ring assembly.

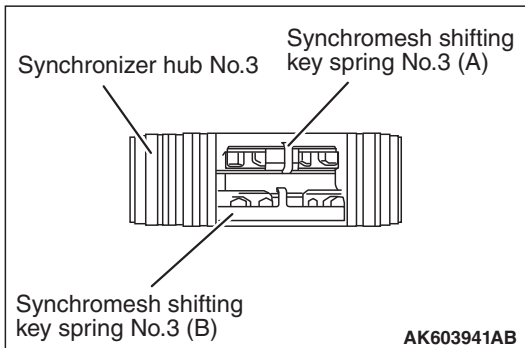

3. Compress the key springs into place inside the hub as shown.

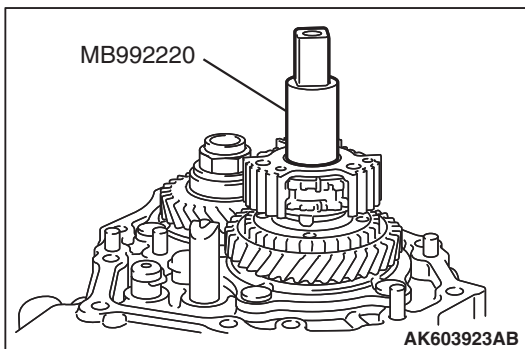

4. Install special tool MB992220 until it hits the end face of the input shaft.

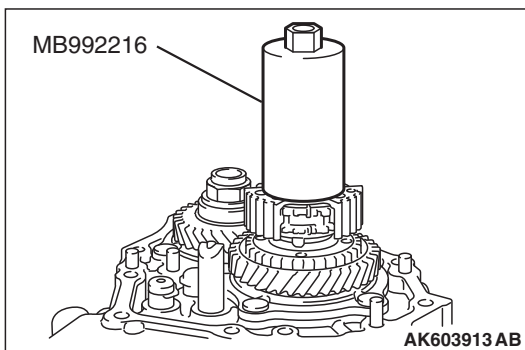

5. Set special tool MB992216 on top of the synchronizer hub No. 3.

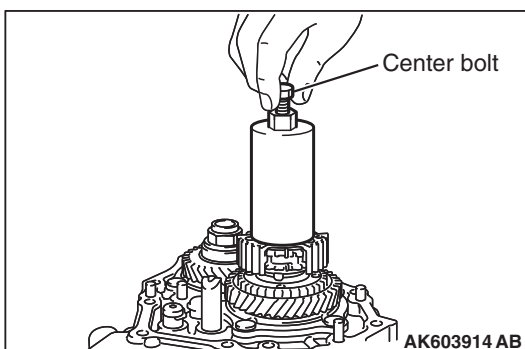

6. Install the center bolt that is a part of the set of special tool MB992216 as shown.

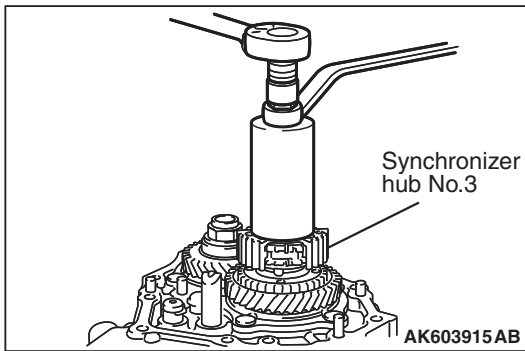

7. Press-fit the synchronizer hub No. 3 as shown.

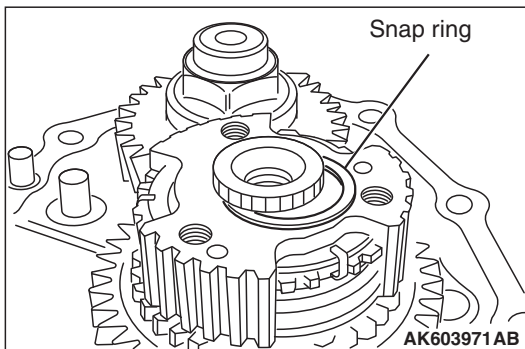

### >>H<< SHAFT SNAP RING INSTALLATION

Select a shaft snap ring that allows distance of the thrust crevice of synchronizer hub No.3 to fall within the standard value range.

**Standard value: 0 –0.1 mm (0 –0.004 in.)**

*NOTE: Try on snap rings in the decreasing order of thickness, and install the first one that fits into the hub.*

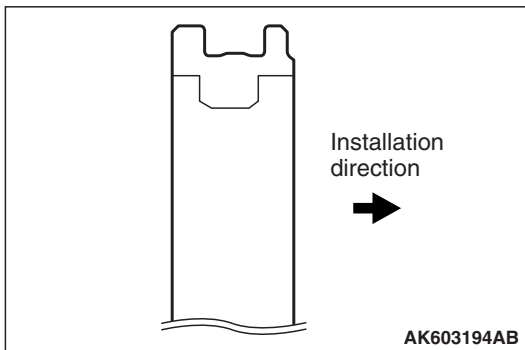

### >>I<< SYNCHRONIZER SLEEVE NO.3 INSTALLATION

Put the synchronizer sleeve No. 3 and gear shaft fork assembly No. 3 together, then install the synchronizer sleeve No. 3 in the illustrated direction.

### >>J<< TRANSAXLE CASE COVER SUB ASSEMBLY INSTALLATION

1. Completely degrease the FIPG-applied surface so that water and oil including the old sealant cannot adhere to the surface coated with the sealant.  
Never touch the degreased surface by hand.
2. Apply a 1.2 mm (0.05 inch) diameter bead of sealant as illustrated onto the transaxle case cover sub assembly.

**Specified sealant: Mitsubishi Part No. MD974421 or equivalent**

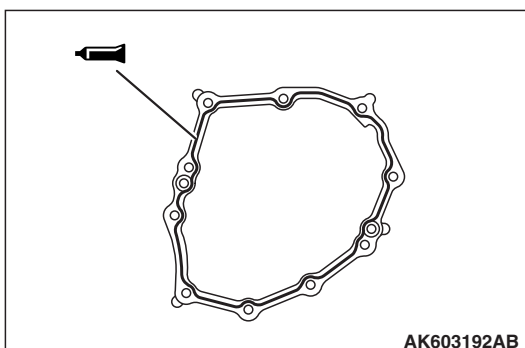

**>>K<< OIL SEAL INSTALLATION**

1. Using special tool MB992212 and MB992075, install the oil seal.
2. Pack grease to the oil seal lip area.

**Specified grease: Mitsubishi Part No. 0101011 or equivalent**

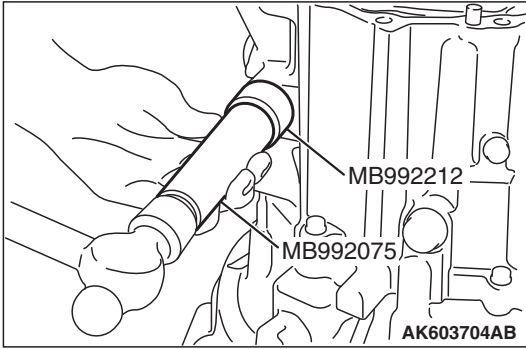

**>>L<< CONTROL SHIFT RETAINER GASKET INSTALLATION**

Install the control shift retainer gasket to the control shaft cover with the projection of the gasket in the illustrated position.

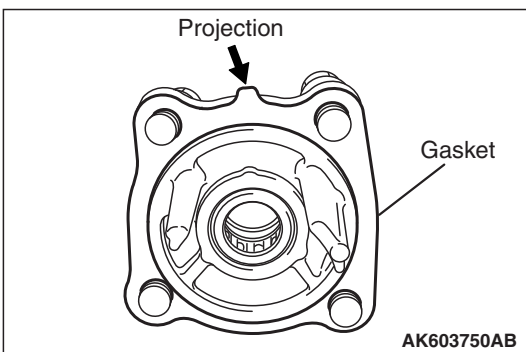

**>>M<< PLUG INSTALLATION**

Using special tool MB992000, install the plug.

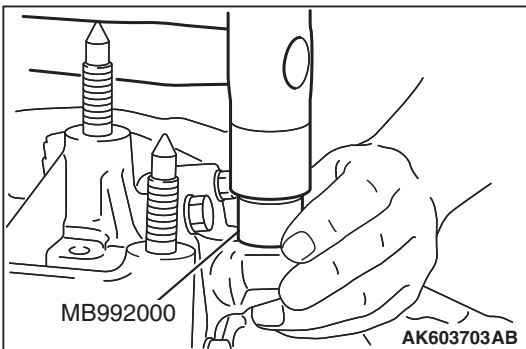

INSPECTION

M1222016600050

BACKUP LIGHT SWITCH

Check for continuity between terminals.

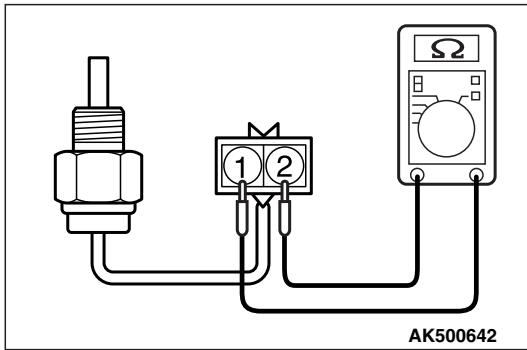

Switch Condition	Continuity
Pressed	Conductive
Released	Open

INPUT SHAFT

DISASSEMBLY AND ASSEMBLY

M1222001600775

Apply gear oil to all moving parts before installation.

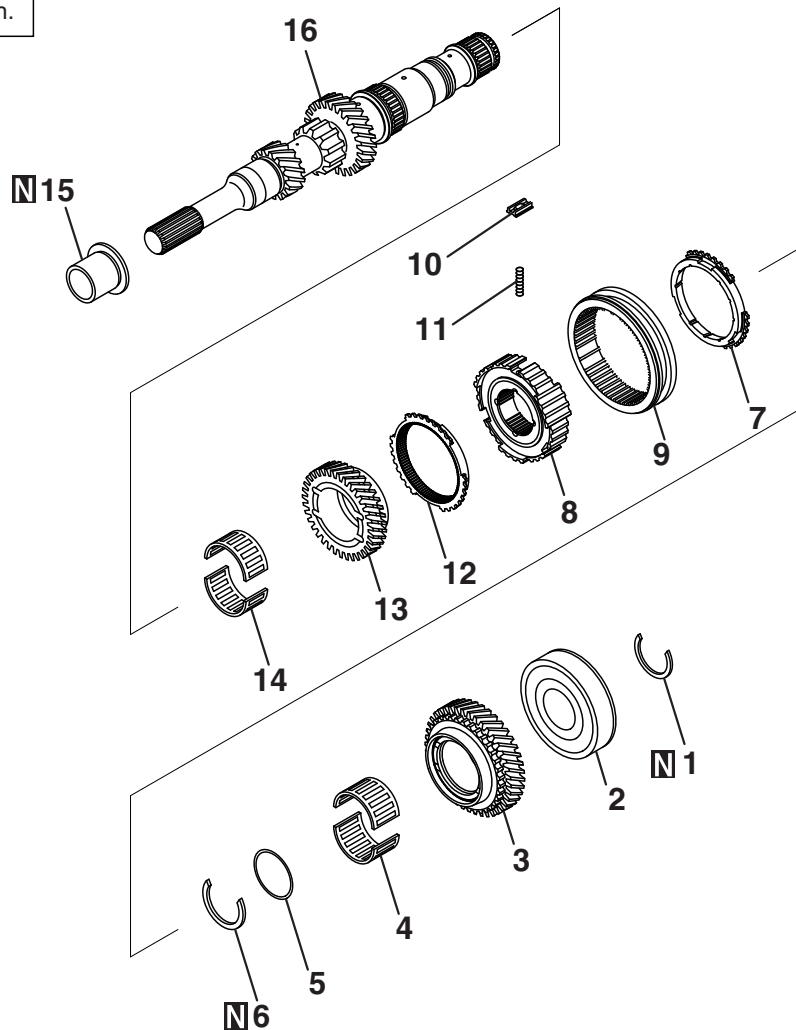

AK703231AC



		Removal steps			Removal steps (Continued)
<<A>>	>>E<<	1. Snap ring			9. Synchromesh shifting key No2
	>>D<<	2. Radial ball bearing	<<B>>	>>B<<	10. Compression spring
		3. 4th gear sub-assembly			11. Synchronizer hub No.2
		4. Needle roller bearing	<<B>>		12. Synchronizer ring No.3
	>>C<<	5. Spacer			13. 3rd gear sub-assembly
		6. Snap ring	<<C>>	>>A<<	14. Needle roller bearing
		7. Synchronizer ring No.4			15. Cylindrical roller bearing
<<B>>	>>B<<	8. Synchronizer sleeve No.2			16. Input shaft

**Required Special Tools:**

- MD998917: Bearing remover
- MB990560: Rear axle shaft bearing remover
- MD998812: Installer cap
- MD998813: Installer-100
- MD998818: Installer adapter
- MD998820: Installer adapter

**DISASSEMBLY SERVICE POINTS**

**<<A>> RADIAL BALL BEARING REMOVAL**

Using special tool MD998917, support the radial ball bearing and remove the radial ball bearing.

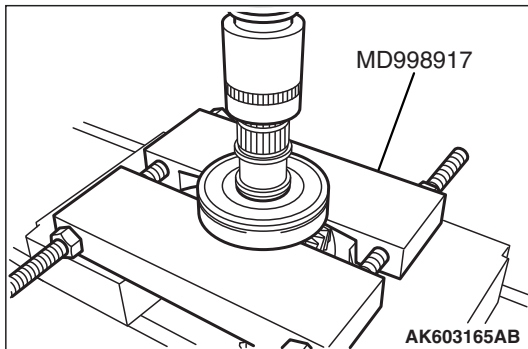

**<<B>> SYNCHRONIZER SLEEVE NO.2, SYNCHRONIZER HUB NO.2 AND 3RD GEAR SUB-ASSEMBLY REMOVAL**

Using special tool MD998917, support the 3rd gear sub-assembly and remove the 3rd gear sub-assembly, synchronizer sleeve No.2 and synchronizer hub No.2.

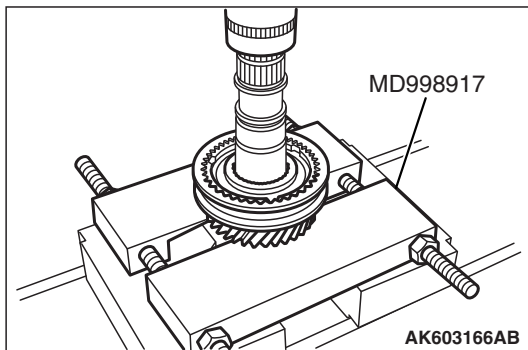

**<<C>> CYLINDRICAL ROLLER BEARING  
REMOVAL**

Using special tool MB990560, support the cylindrical roller bearing and remove the cylindrical roller bearing.

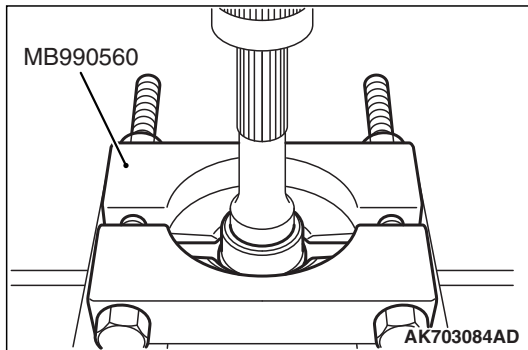
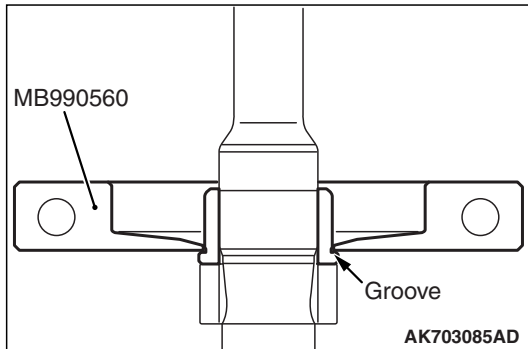

**ASSEMBLY SERVICE POINTS**

**>>A<< CYLINDRICAL ROLLER BEARING INSTAL-  
LATION**

1. Check the installation direction of the cylindrical roller bearing.

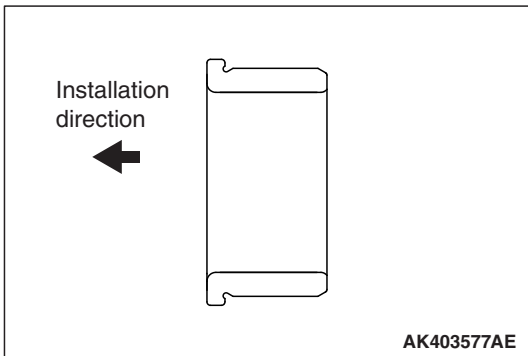

2. Using special tools MD998812, MD998813 and MD998818, install the cylindrical roller bearing.

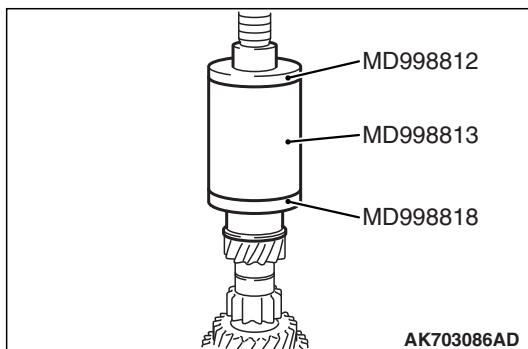

### >>B<< SYNCHRONIZER HUB NO.2 AND SYNCHRONIZER SLEEVE NO.2 INSTALLATION

1. Before assembly, make sure that the hub and sleeve face the correct direction.

**NOTE:**

- Apply gear oil to the caulked area between the sleeve and the hub.
- After installation, confirm the sleeve and the hub slide smoothly.

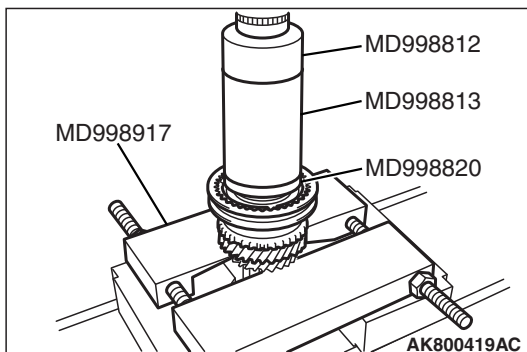
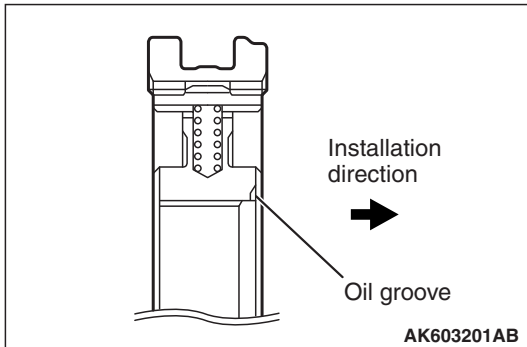

2. Using special tools MD998812, MD998813, MD998820 and MD998917, install the synchronizer sleeve No.2 and synchronizer hub No.2.

### >>C<< SNAP RING INSTALLATION

Select a snap ring that allows distance of the thrust crevice of synchronizer hub No.2 to fall within the standard value range.

**Standard value: 0 –0.1 mm (0 –0.004 inch)**

**NOTE:** Note: Try on snap rings in the decreasing order of thickness, and install the first one that fits into the input shaft.

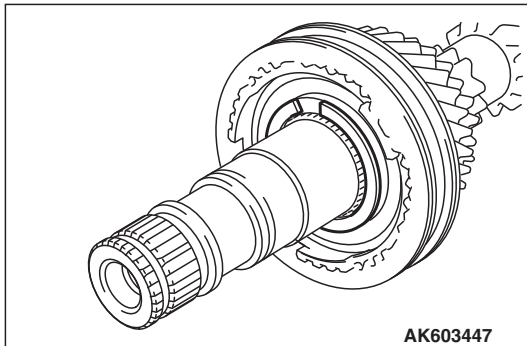

### >>D<< RADIAL BALL BEARING INSTALLATION

1. Before assembly, make sure that the radial ball bearing faces the correct direction.

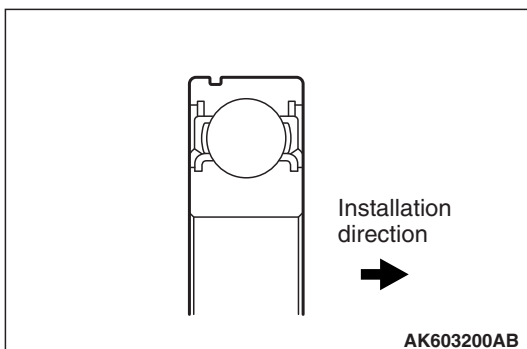

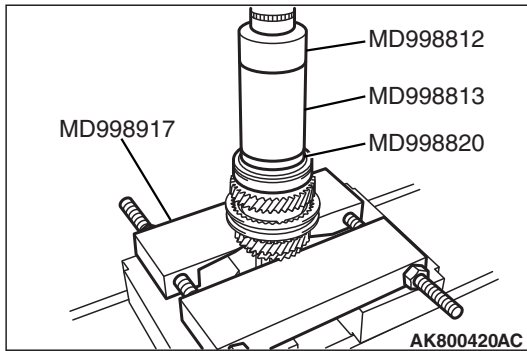

- Using special tools MD998812, MD998813, MD998820 and MD998917, install the radial ball bearing.

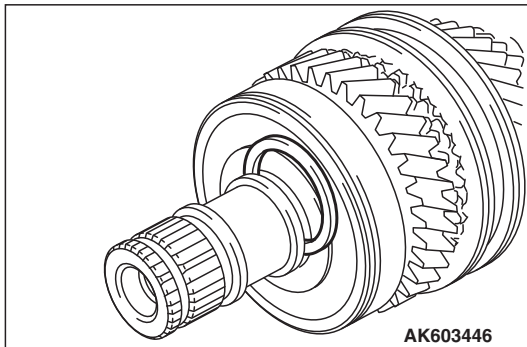

### >>E<< SNAP RING INSTALLATION

Select a snap ring that allows distance of the thrust crevice of radial ball bearing to fall within the standard value range.

**Standard value: 0 –0.1 mm (0 –0.004 inch)**

*NOTE: Note: Try on snap rings in the decreasing order of thickness, and install the first one that fits into the input shaft.*

# OUTPUT SHAFT

## DISASSEMBLY AND ASSEMBLY

M1222002200480

Apply gear oil to all moving parts before installation.

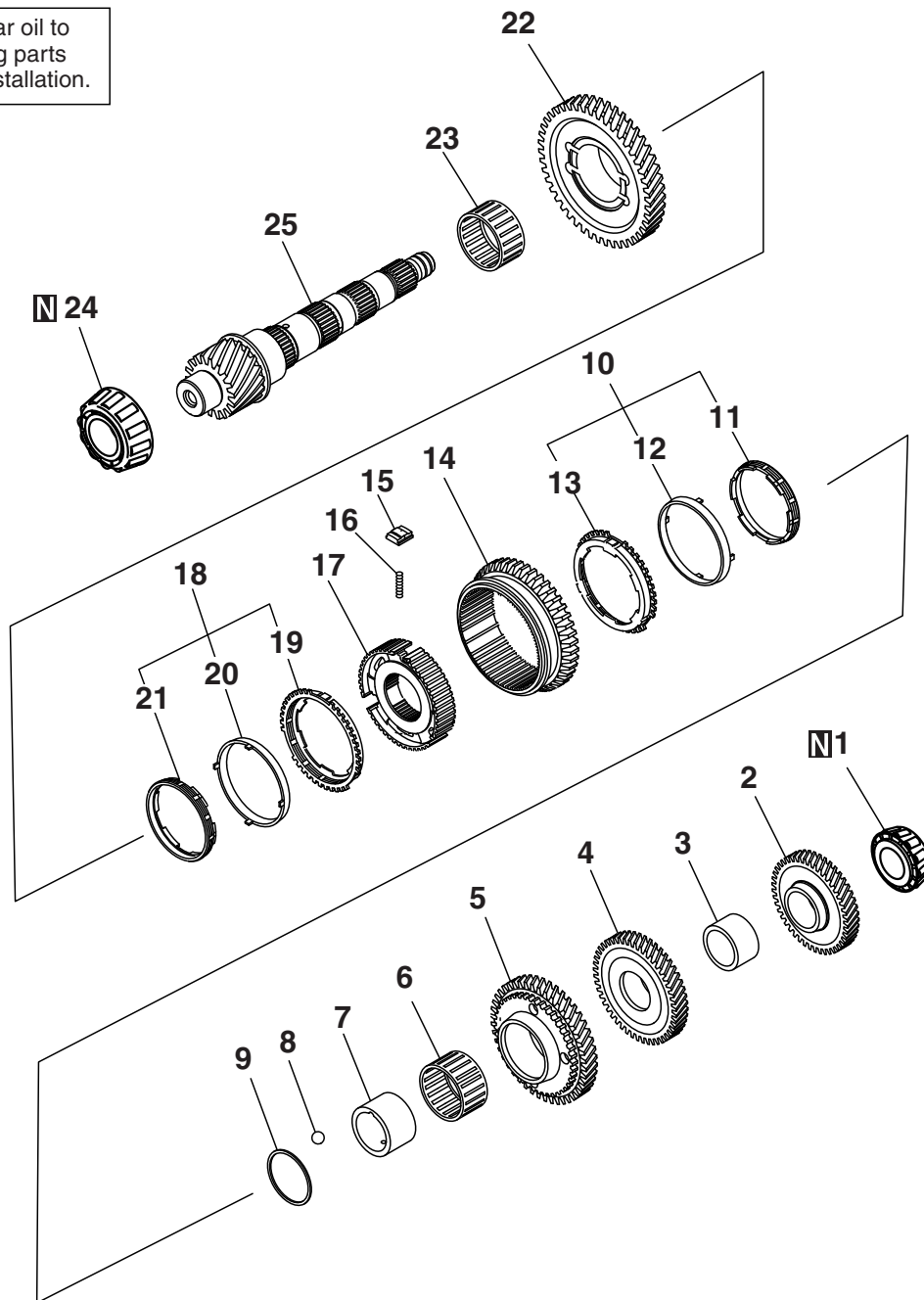

AK603531AB

### Removal steps

- <<A>> >>G<< 1. Tapered roller bearing inner race
- <<A>> >>F<< 2. 4th drive gear
- 3. Spacer
- <<B>> >>E<< 4. 3rd drive gear
- <<B>> >>D<< 5. 2nd gear
- 6. Needle roller bearing
- 7. 2nd gear bush
- 8. Ball
- 9. Spacer
- >>D<< 10. Synchronizer ring set No.2

### Removal steps (Continued)

- >>D<< 11. Synchronizer inner ring No.2
- >>D<< 12. Synchronizer middle ring No.2
- >>D<< 13. Synchronizer outer ring No.2
- <<C>> >>C<< 14. Reverse gear
- 15. Synchromesh shifting key No1
- 16. Compression spring
- <<C>> >>C<< 17. Synchronizer hub No.1
- >>B<< 18. Synchronizer ring set No.1
- >>B<< 19. Synchronizer outer ring No.1
- >>B<< 20. Synchronizer middle ring No.1

**Removal steps (Continued)**

- >>B<< 21. Synchronizer inner ring No.1  
<<C>> >>B<< 22. 1st gear  
23. Needle roller bearing  
<<D>> >>A<< 24. Tapered roller bearing  
25. output shaft

**Required Special Tools:**

- MD998917: Bearing remover
- MD998368: Bearing installer
- MD998812: Installer cap
- MD998813: Installer-100
- MD998820: Installer adapter
- MD998814: Installer 200
- MD998819: Installer adapter

**DISASSEMBLY SERVICE POINTS****<<A>> TAPERED ROLLER BEARING INNER RACE AND 4TH DRIVE GEAR REMOVAL**

Using special tool MD998917, support the 4th drive gear and remove the tapered roller bearing Inner race and 4th drive gear.

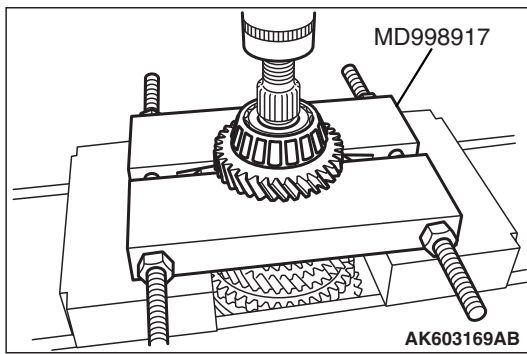
**<<B>> 3RD DRIVE GEAR AND 2ND GEAR REMOVAL**

Using special tool MD998917, support the 2nd gear and remove the 3rd drive gear and 2nd gear.

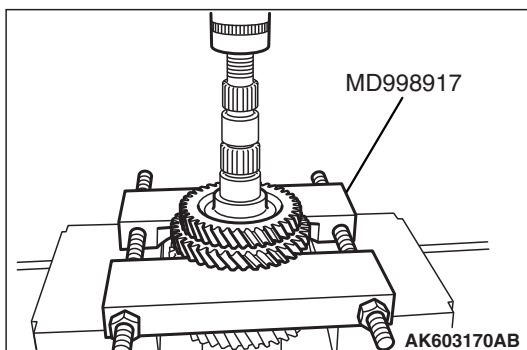

**<<C>> REVERSE GEAR, SYNCHRONIZER HUB  
NO.1 AND 1ST GEAR REMOVAL**

Using special tool MD998917, support the 1st gear and remove the 1st gear, reverse gear and synchronizer hub No.1.

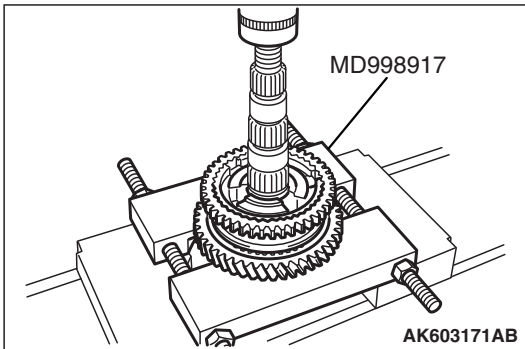

**<<D>> TAPERED ROLLER BEARING INNER  
RACE REMOVAL**

Using special tool MD998917 and MD998368, support the tapered roller bearing Inner race and remove the tapered roller bearing Inner race.

*NOTE: Since special tool MD998917 holds the tapered roller bearing at the roller portion, the roller portion is broken when the inner race is removed.*

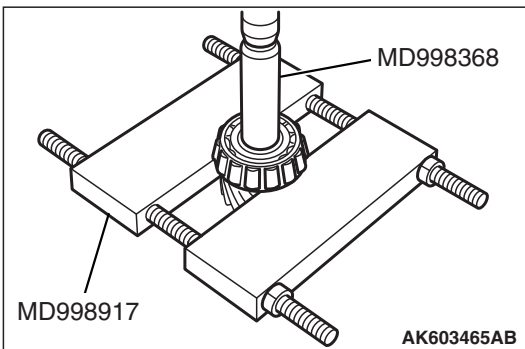

**ASSEMBLY SERVICEPOINTS**

**>>A<< TAPERED ROLLER BEARING INNER  
RACE INSTALLATION**

Using special tools MD998812, MD998813 and MD998820, install the tapered roller bearing inner race.

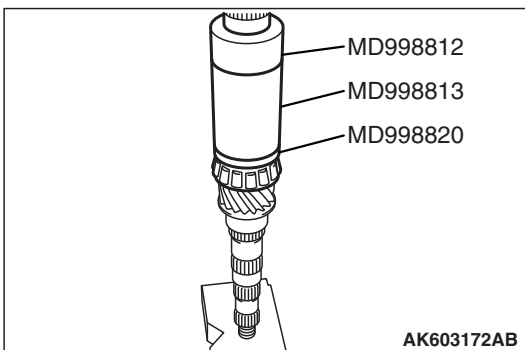

### >>B<< SYNCHRONIZER RING SET NO.1 (SYNCHRONIZER OUTER RING NO.1, SYNCHRONIZER MIDDLE RING NO.1, SYNCHRONIZER INNER RING NO.1) INSTALLATION

#### CAUTION

The rings of the synchronizer ring set No. 1 and No. 2 are dedicated to the 1st and 2nd gears. Be sure to install the right ring set to the right gear.

1. Make sure that the synchronizer outer ring of the synchronizer ring set No. 1 is as shown.

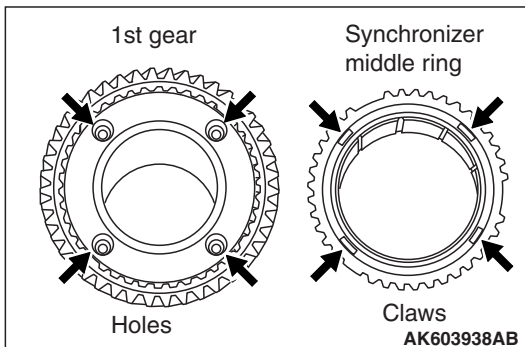
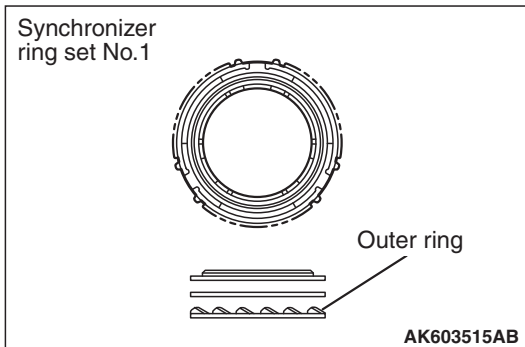

2. Install the synchronizer ring set No. 1 aligning the claws of the synchronizer middle ring to the positioning holes in the 1st gear.

*NOTE: Apply gear oil to the sufficiently on the sliding surface*

### >>C<< REVERSE GEAR AND SYNCHRONIZER HUB NO.1 INSTALLTION

1. Install the reverse gear onto the synchronizer hub in the illustrated direction.

*NOTE: Apply gear oil to the sufficiently on the sliding surface*

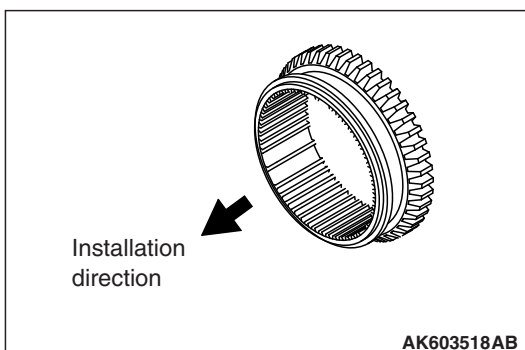



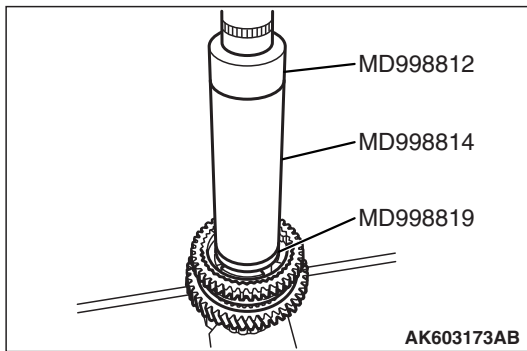

2. Using special tools MD998812, MD998814 and MD998819, install the synchronizer hub and reverse gear.
3. After installation, confirm the 1st gear slides smoothly.

**>>D<< SYNCHRONIZER RING SET NO.2  
(SYNCHRONIZER OUTER RING NO.2,  
SYNCHRONIZER MIDDLE RING NO.2,  
SYNCHRONIZER INNER RING NO.2) AND 2ND  
GEAR INSTALLATION**

**⚠ CAUTION**

The rings of the synchronizer ring set No. 1 and No. 2 are dedicated to the 1st and 2nd gears. Be sure to install the right ring set to the right gear.

1. Make sure that the synchronizer outer ring of the synchronizer ring set No. 2 is as shown.

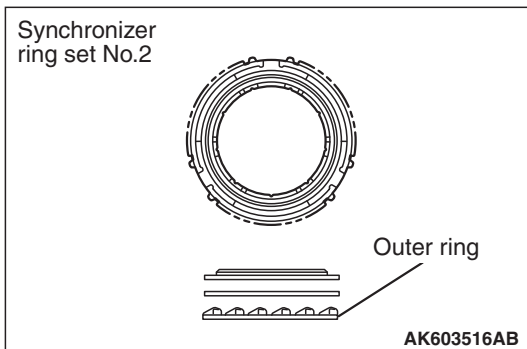

2. Install the synchronizer ring set No. 2 to the 2nd gear aligning the claws of the synchronizer middle ring to the positioning holes in the 2nd gear.

*NOTE: Apply gear oil to the sufficiently on the sliding surface*

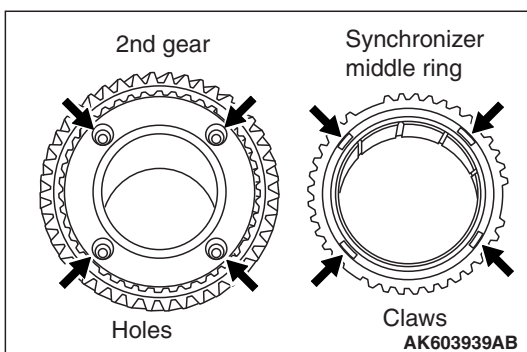

**>>E<< 3RD DRIVE GEAR INSTALLATION**

Using special tools MD998812, MD998813 and MD998819, install the 3rd drive gear.

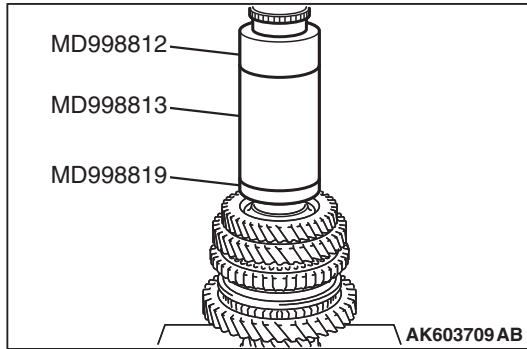
**>>F<< 4TH DRIVE GEAR INSTALLATION**

Using special tools MD998812, MD998813 and MD998819, install the 4th drive gear.

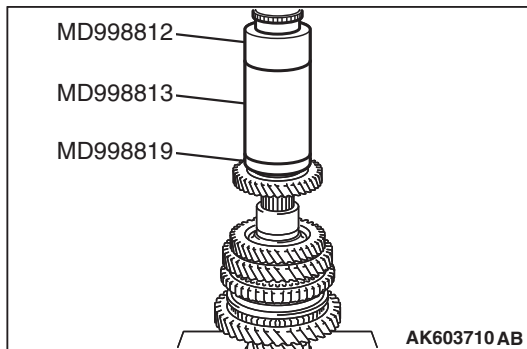
**>>G<< TAPERED ROLLER BEARING INNER RACE INSTALLATION**

Using special tools MD998812, MD998813 and MD998819, install the tapered roller bearing inner race.

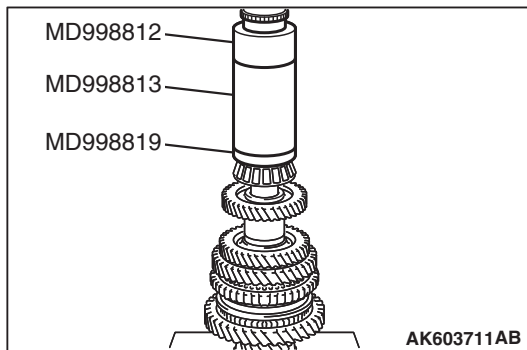

# SELECT LEVER

## DISASSEMBLY AND ASSEMBLY

M1222012800397

 Apply gear oil to all moving parts before installation.

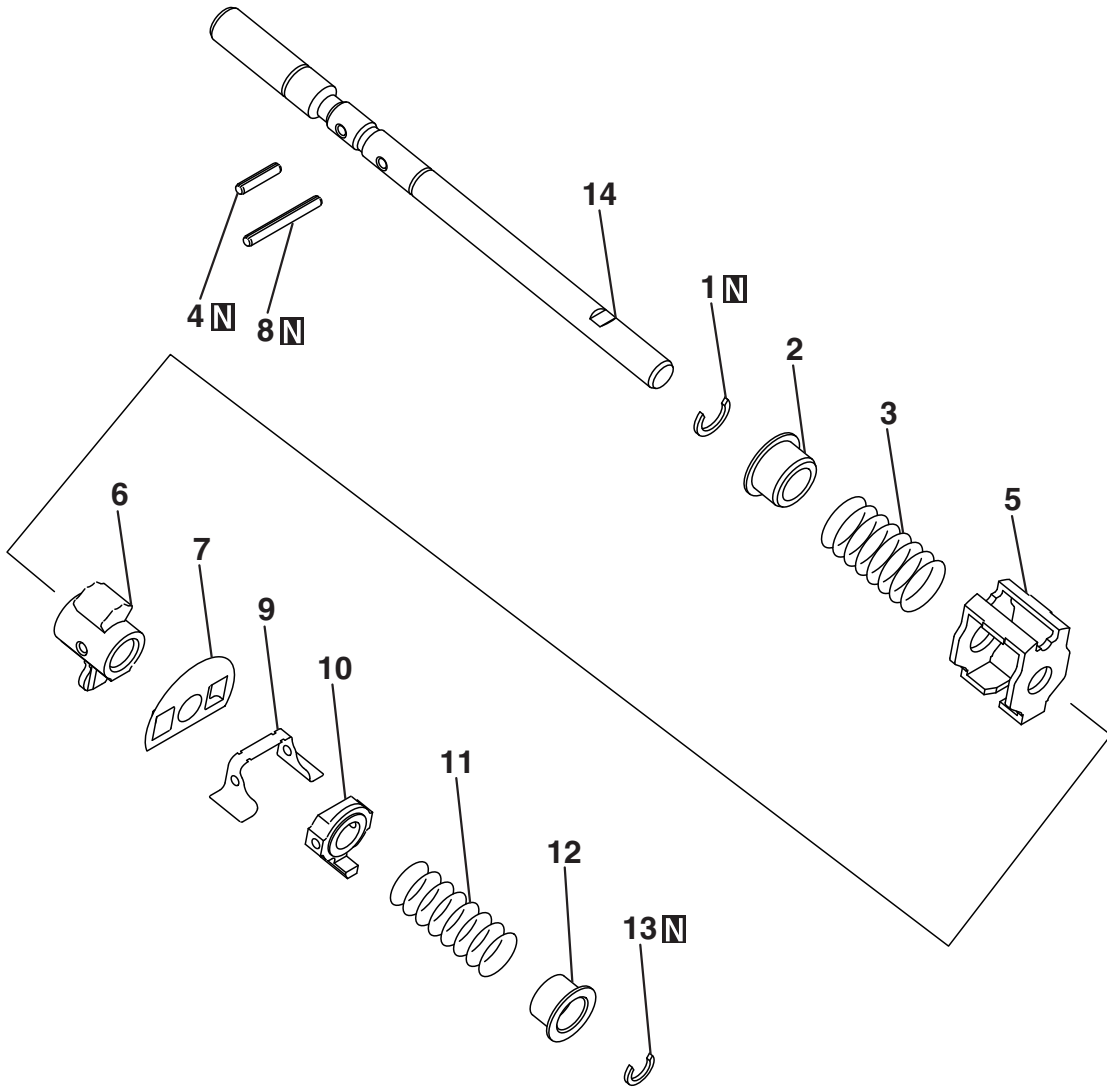

AK603532AB

**Removal steps**

- >>B<<
1. Shaft snap ring
  2. Select spring seat
  3. Spring
  4. Slotted spring pin
  5. Shift inter lock plate
  6. Shift inner lever No.1
  7. Shift inter lock plate cover

**Removal steps (Continued)**

- >>A<<
8. Slotted spring pin
  9. Transmission oil baffle
  10. Shift inner lever No.2
  11. Spring
  12. Select spring shift No.2
  13. Shaft snap ring
  14. Shift and select lever shaft

**ASSEMBLY SERVICE POINTS****>>A<< SLOTTED SPRING PIN INSTALLATION**

Drive in the slotted spring pin to the illustrated dimension.

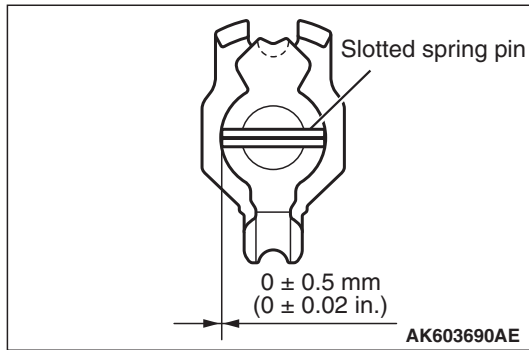
**>>B<< SLOTTED SPRING PIN INSTALLATION**

Drive in the slotted spring pin to the illustrated dimension.

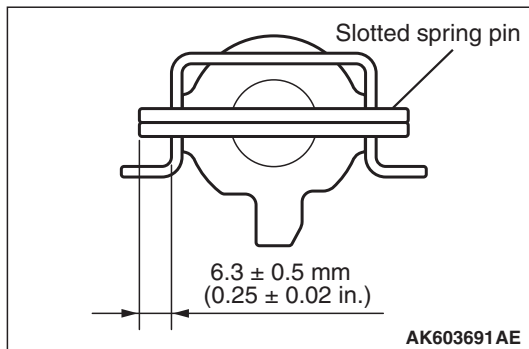

# BELLCRANK

## BELLCRANK DISASSEMBLY AND ASSEMBLY

M1222016800087

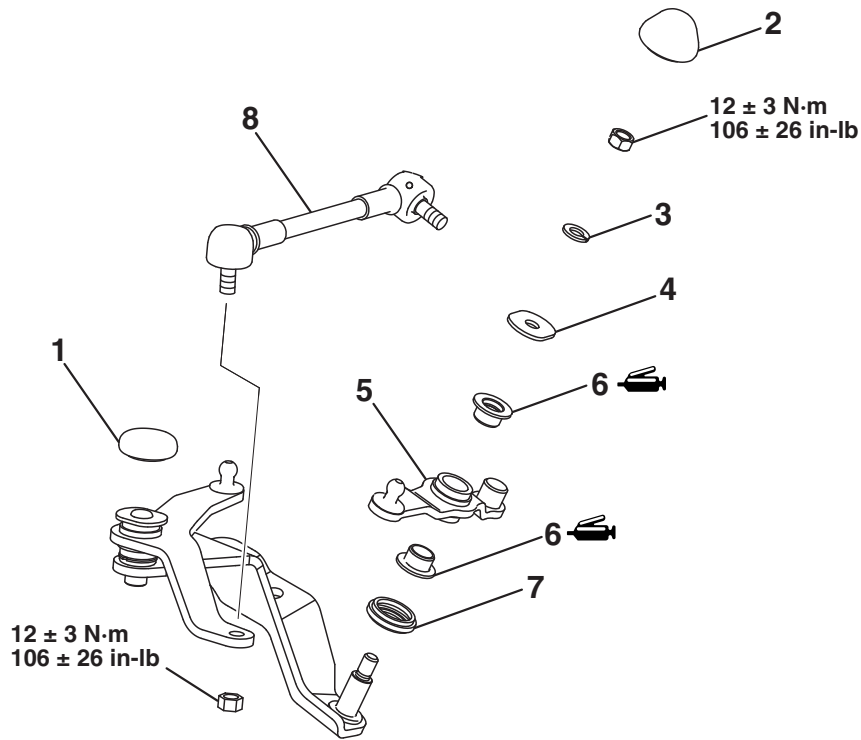

AK701314AG

- >>C<<**
- >>B<<**
- Disassembly steps**
1. Shaft boot
  2. Shaft boot
  3. Wave washer
  4. Washer

- >>A<<**
- Disassembly steps (Continued)**
5. Select shaft lever
  6. Bushing
  7. Shaft boot
  8. Select lever shaft

## ASSEMBLY SERVICE POINTS

## &gt;&gt;A&lt;&lt; SHAFT BOOT INSTALLATION

Install the shaft boot so that the stamp can be oriented as shown in the illustration.

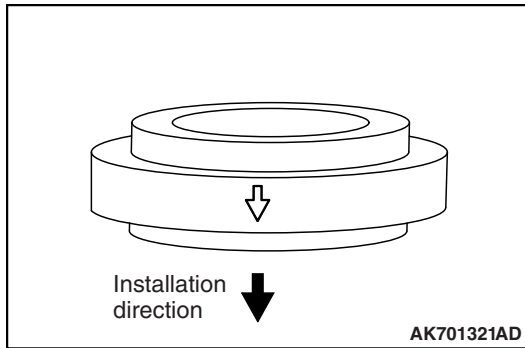

## &gt;&gt;B&lt;&lt; SHAFT BOOT INSTALLATION

Fit the shaft boot into the groove.

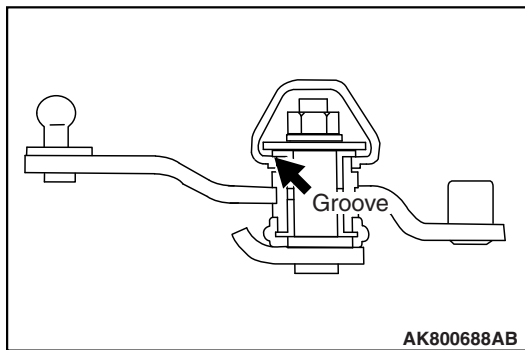

## &gt;&gt;C&lt;&lt; SHAFT BOOT INSTALLATION

Fit the shaft boot into the groove.

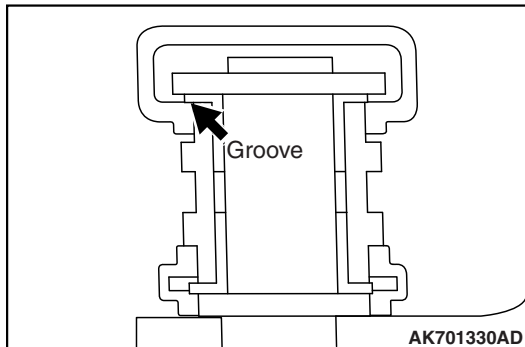

# CLUTCH HOUSING

## DISASSEMBLY AND ASSEMBLY

M1222003700671

Apply gear oil to all moving parts before installation.

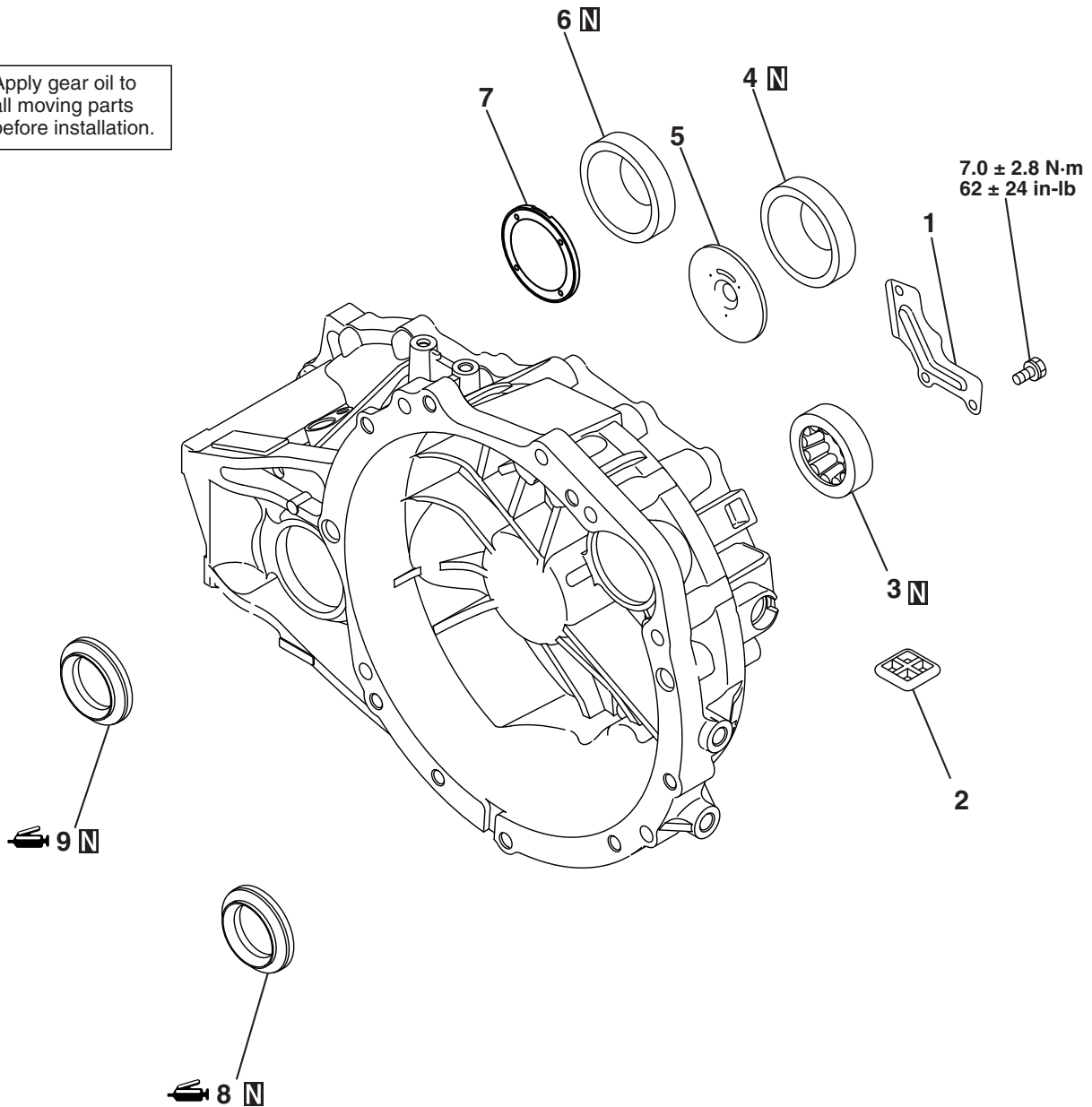

AK603533AB

### Removal steps

- |       |       |  |
|-------|-------|--|
|       | 1.    | Transaxle case receiver                    |
|       | 2.    | Magnet                                     |
| <<A>> | >>G<< | 3. Cylindrical roller bearing (outer race) |
| <<B>> | >>F<< | 4. Tapered roller bearing outer race       |

### Removal steps (Continued)

- |       |       |                                      |
|-------|-------|--------------------------------------|
| >>E<< | 5.    | Out put shaft cover                  |
| <<C>> | >>D<< | 6. Tapered roller bearing outer race |
|       | >>C<< | 7. Extension housing oil baffle      |
|       | >>B<< | 8. Oil seal                          |
|       | >>A<< | 9. Oil seal                          |

### Required Special Tools:

- |  |   |
|--|---|
| • MB990211: Slide hammer                     | • MB991445: Bush remover & installer base   |
| • MB992039: Slide hammer puller              | • MB990938: Installer bar                   |
| • MD998200: Oil seal installer               | • MD999547: Oil seal installer              |
| • MD998550: Extension housing seal installer | • MB990699: Differential oil seal installer |

**DISASSEMBLY SERVICE POINTS****<<A>> CYLINDRICAL ROLLER BEARING (OUTER RACE) REMOVAL**

1. Using special tools MB990211 and MB992039, remove the cylindrical roller bearing (outer race).

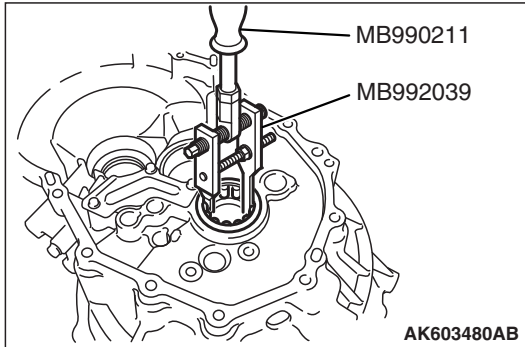
**<<B>> TAPERED ROLLER BEARING OUTER RACE REMOVAL**

1. Using special tools MB990211 and MB992039, remove the tapered roller bearing outer race.

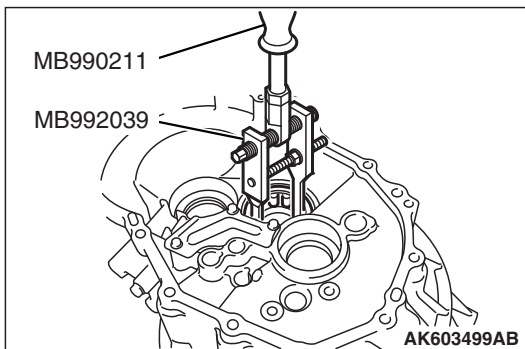
**<<C>> TAPERED ROLLER BEARING OUTER RACE REMOVAL**

1. Using special tools MB990211 and MB992039, remove the tapered roller bearing outer race.

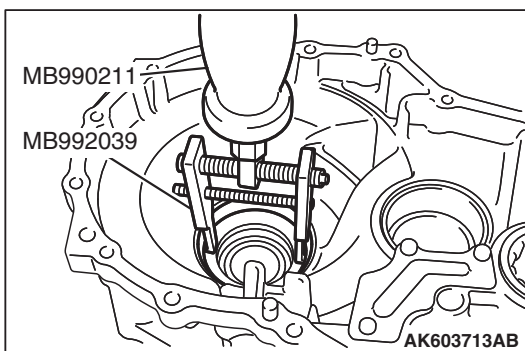



## ASSEMBLY SERVICE POINTS

### >>A<< OIL SEAL INSTALLATION

Using special tools MD998550, install the oil seal.

**Specified grease: Mitsubishi Part No. 0101011 or equivalent**

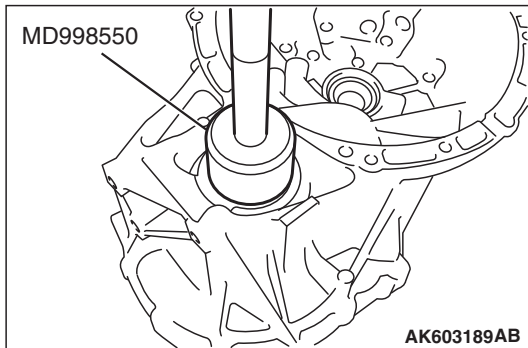

### >>B<< OIL SEAL INSTALLATION

Using special tools MD998200, install the oil seal.

**Specified grease: Mitsubishi Part No. 0101011 or equivalent**

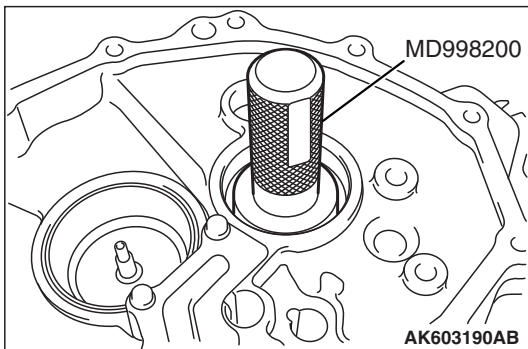

### >>C<< EXTENSION HOUSING OIL BAFFLE INSTALLATION

Install the extension housing oil baffle to the clutch housing case assembly with its projections fitted in the slots in the clutch housing case assembly.

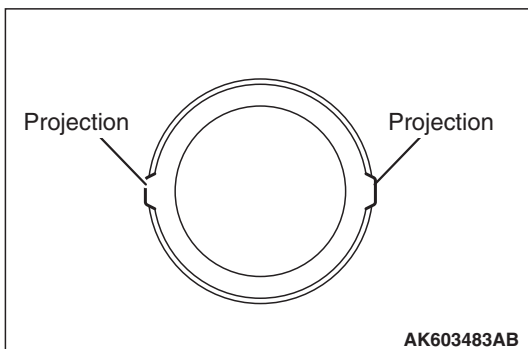

**>>D<< TAPERED ROLLER BEARING OUTER RACE INSTALLATION**

Using special tools MB991445 and MB990938, install the tapered roller bearing outer race.

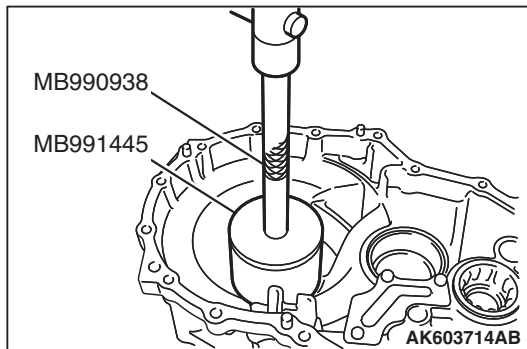
**>>E<< OUTPUT SHAFT COVER INSTALLATION**

Install the output shaft cover to the clutch housing case assembly with its projections fitted in the slots in the clutch housing case assembly. Make sure that the oil hole in the output shaft cover is up as shown.

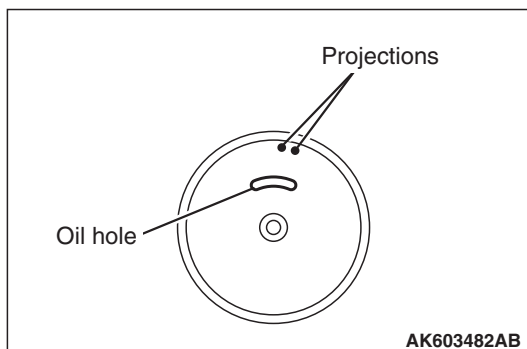
**>>F<< TAPERED ROLLER BEARING OUTER RACE INSTALLATION**

Using special tool MB990699 and install the tapered roller bearing outer race.

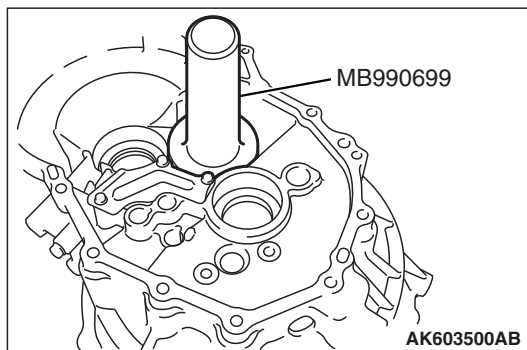

**>>G<< CYLINDRICAL ROLLER BEARING (OUTER RACE) INSTALLATION**

Using special tools MD999547, install the cylindrical roller bearing (outer race).

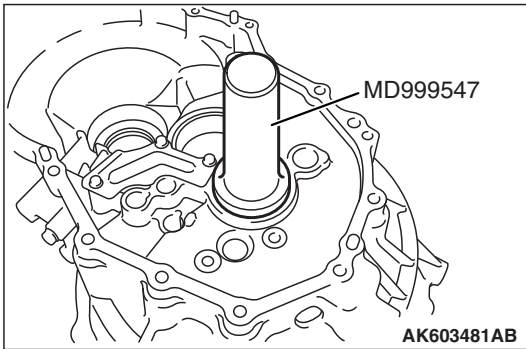

# TRANSAXLE CASE

## DISASSEMBLY AND ASSEMBLY

M1222016300071

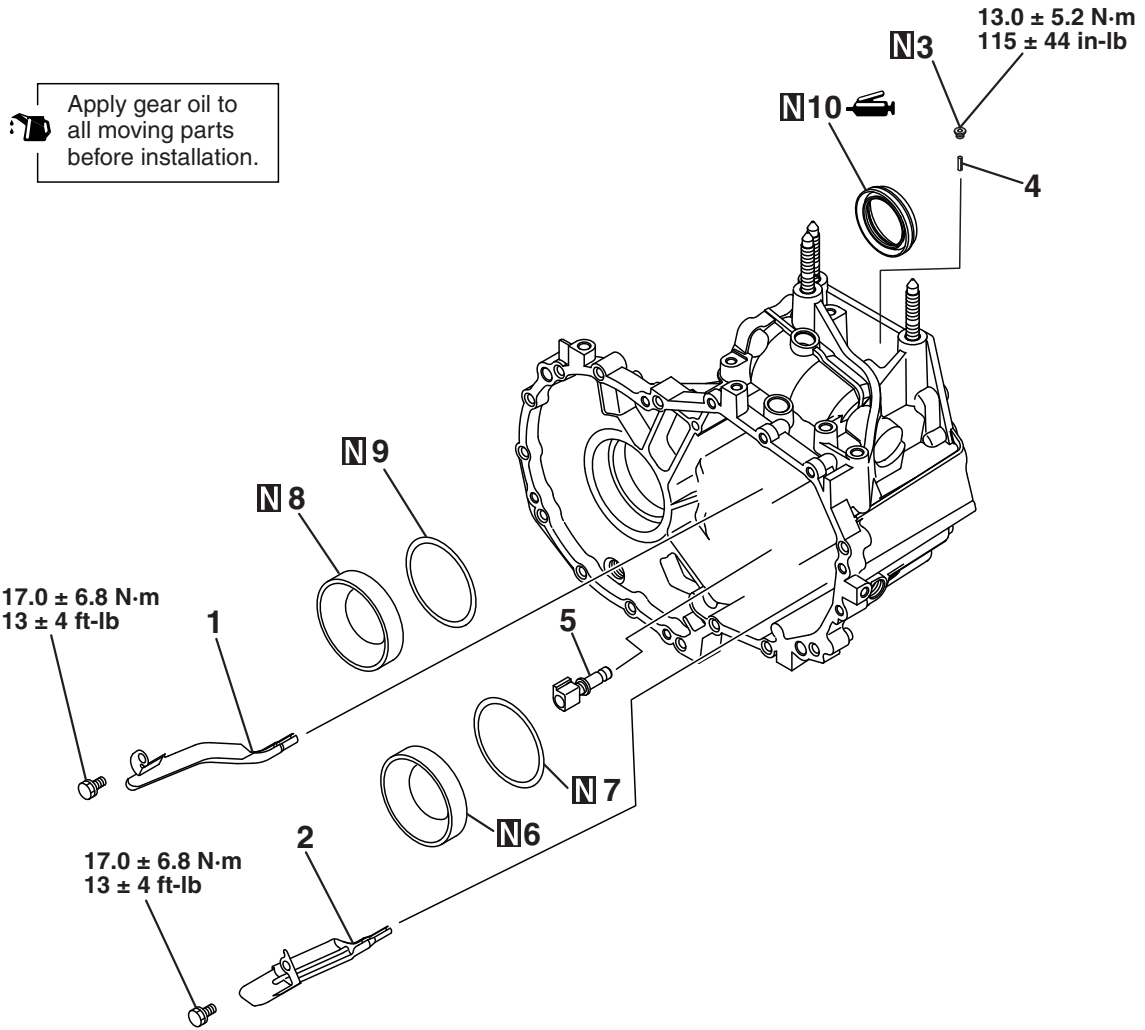

AK603534AH

### Removal steps

1. Oil receiver pipe A
2. Oil receiver pipe B
3. With head straight screw plug
4. Slotted spring pin
5. Reverse restrict pin assembly

### Removal steps (Continued)

- |       |       |                                      |
|-------|-------|--------------------------------------|
| <<A>> | >>C<< | 6. Tapered roller bearing outer race |
|       |       | 7. Shim                              |
| <<B>> | >>B<< | 8. Tapered roller bearing outer race |
|       |       | 9. Shim                              |
|       | >>A<< | 10. Oil seal                         |

### Required Special Tools:

- MB991015: Knuckle oil seal installer
- MB990211: Slide hammer
- MB992039: Slide hammer puller
- MB992210: Oil seal installer
- MB992075: Handle
- MB991966: Bearing outer race installer
- MB990938: Installer bar

**DISASSEMBLY SERVICE POINTS**

**<<A>> TAPERED ROLLER BEARING OUTER RACE REMOVAL**

Using special tools MB991015, remove the tapered roller bearing outer race.

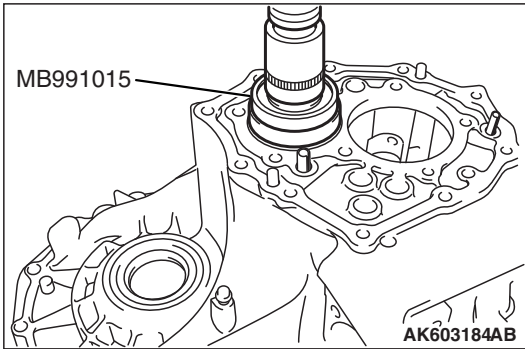

**<<B>> TAPERED ROLLER BEARING OUTER RACE REMOVAL**

Using special tools MB990211 and MB992039, remove the tapered roller bearing outer race.

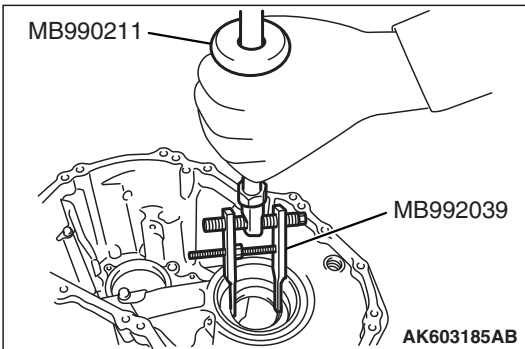

**ASSEMBLY SERVICE POINTS****>>A<< OIL SEAL INSTALLATION**

1. Using special tools MB992210 and MB992075, press-fit the oil seal until the difference in height between the transaxle case and oil seal is obtained as shown.
2. Pack grease to the oil seal lip area.

**Specified grease: Mitsubishi Part No. 0101011 or equivalent**

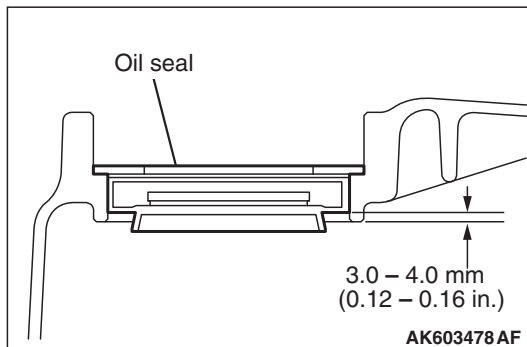
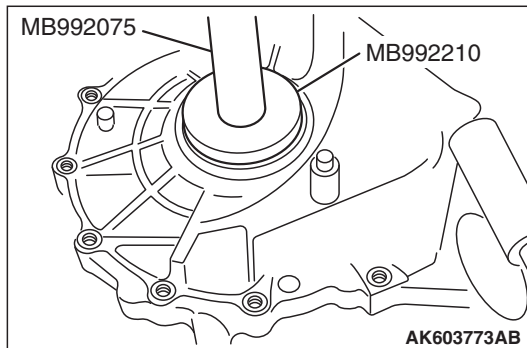
**>>B<< TAPERED ROLLER BEARING OUTER RACE INSTALLATION**

Using special tools MB991966, Install the tapered roller bearing outer race.

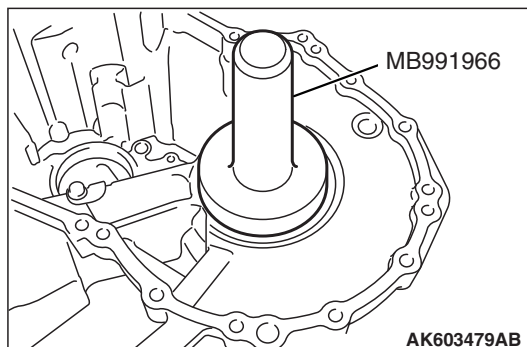
**>>C<< TAPERED ROLLER BEARING OUTER RACE INSTALLATION**

1. Set special tools MB991015 and MB990938.

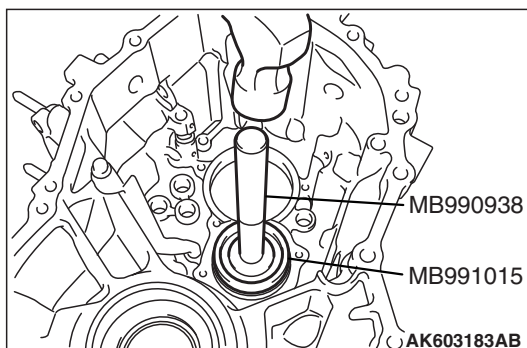

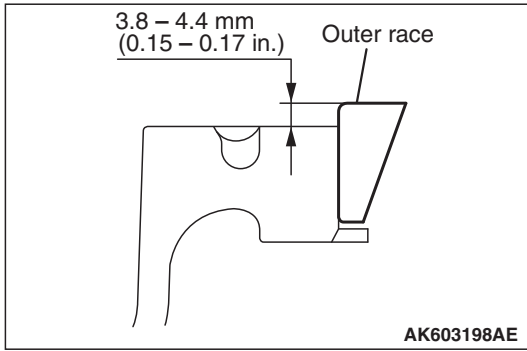

2. Press-fit the tapered roller bearing outer race to the height shown in the illustration.

**DIFFERENTIAL**

**DISASSEMBLY AND ASSEMBLY**

M1222002500351

Apply gear oil to all moving parts before installation.

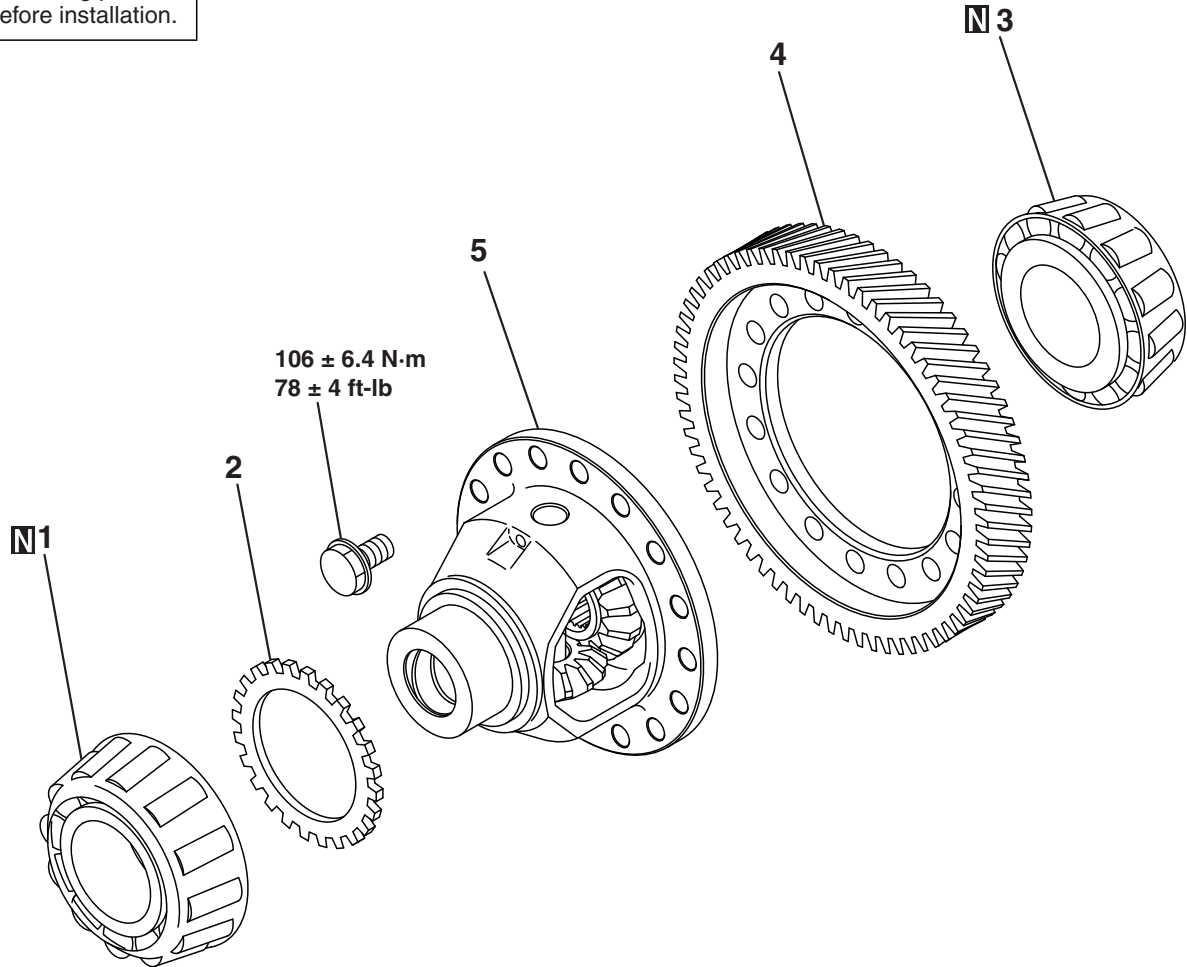

AK603535AB

**Removal steps**

- <<A>> >>C<< 1. Tapered roller bearing inner race
- <<B>> >>B<< 2. Speedometer drive gear
- <<C>> >>A<< 3. Tapered roller bearing inner race

**Removal steps (Continued)**

- 4. Ring gear
- 5. Differential case assembly

**Required Special Tools:**

- MD998917: Bearing remover
- MB991395: Crankshaft front oil seal installer
- MB990810: Side bearing puller
- MD999566: Crow
- MD998812: Installer cap
- MB992150: Oil seal installer
- MB990891: Rear suspension bushing base
- MB992138: Bearing installer

TSB Revision



## DISASSEMBLY SERVICE POINTS

### <<A>> TAPERED ROLLER BEARING INNER RACE REMOVAL

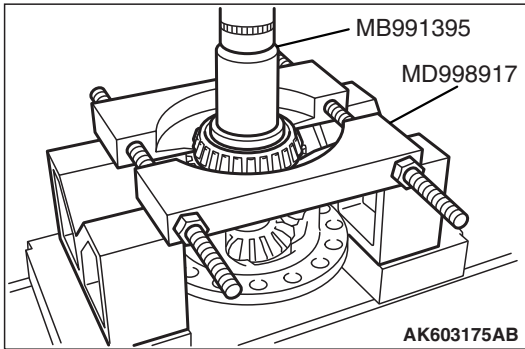

1. Using special tool MD998917 and MB991395, support the tapered roller bearing inner race, and then set them on the press.
2. Push down on the differential case with the press and remove the tapered roller bearing inner race.

### <<B>> SPEEDOMETR DRIVE GEAR REMOVAL

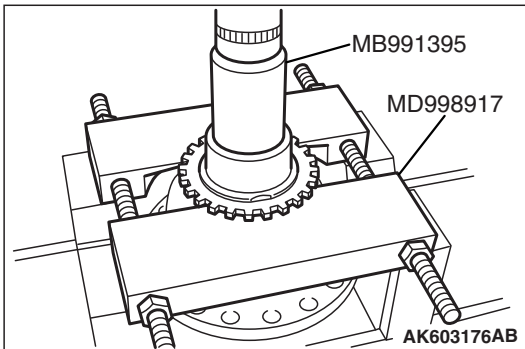

1. Using special tool MD998917 and MB991395, support the speedometer drive gear, and then set them on the press.
2. Push down on the differential case with the press and remove the speedometer drive gear.

### <<C>> TAPERED ROLLER BEARING INNER RACE REMOVAL

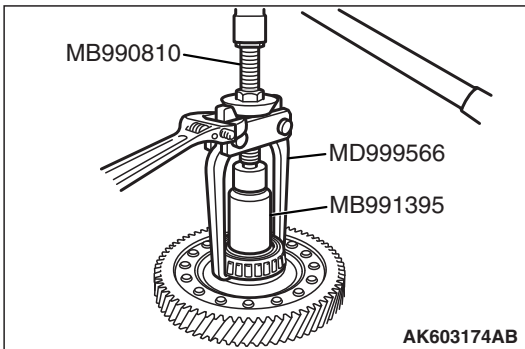

1. Using special tool MB990810, MD999566 and MB991395, remove the tapered roller bearing inner race.
2. Push down on the differential case with the press and remove the tapered roller bearing inner race.

**ASSEMBLY SERVICE POINTS****>>A<< TAPERED ROLLER BEARING INNER RACE INSTALLATION**

Using special tools MD998812 and MB992150, install the tapered roller bearing inner race.

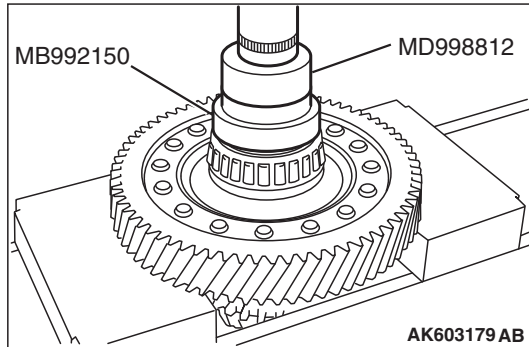
**>>B<< SPEEDOMETR DRIVE GEAR INSTALLATION**

Using special tools MB990891, install the speedometer drive gear.

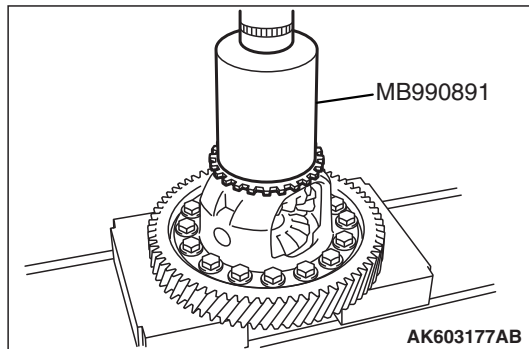
**>>C<< TAPERED ROLLER BEARING INNER RACE INSTALLATION**

Using special tools MB992138, install the tapered roller bearing inner race.

