GROUP 26

FRONT AXLE

CONTENTS

GENERAL INFORMATION 26-2

GENERAL INFORMATION

M2260000101221

The front axle has the following features:

- The wheel bearing is a unit ball bearing (double-row angular contact ball bearing) which incorporates the oil seals and is highly resistant to thrust loads.
- Lead-free grease for the constant velocity joint is adopted.
- Hexavalent chromium is eliminated from the dust cover material.
- The number of parts is reduced by integrating the magnetic encoder for ABS wheel speed detection into the wheel bearing.

<FWD>

- The driveshaft incorporates lightweight and compact EBJ-ETJ type constant velocity joints.
- Dynamic damper is mounted on driveshaft (RH) to reduce differential gear noise.

<AWD>

- The driveshaft incorporates lightweight and compact EBJ-ETJ type constant velocity joints.
- Due to the use of the output shaft, the right and left driveshafts have been approximately the same in length, reducing noise, vibration, and torque steer.

ETJ (High Efficiency Compact Tripod Joint): the lighter and smaller constant velocity joint compared with the conventional TJ has been installed.

EBJ (High Efficiency Compact Birfield Joint): the lighter and smaller constant velocity joint compared with the conventional BJ has been achieved by adopting the eight small balls.

NOTE:

SPECIFICATIONS

Item		Specification		
Wheel bearing	Bearing type	Unit ball bearing (double-row angular contact ball bearing)		
	Bearing (Outer diameter × inside diameter) mm (in)	80 × 43 (3.15 × 1.69)		
Driveshaft	Joint type	Outside	EBJ	
		Inside	ETJ	
	Shaft length* × shaft diameter mm (in)	FWD	M/T-LH	380.5 × 24.5 (15.0 × 1.0)
			M/T-RH	715 × 28 (28.1 × 1.1)
		AWD	CVT-LH	399.5 × 28 (15.7 × 1.1)
			CVT-RH	715 × 28 (28.1 × 1.1)
	LH	340 × 26 (13.4 × 1.0)		
RH		448 × 26 (17.6 × 1.1)		

NOTE: *: Indicates the distance between each joint center.

CONSTRUCTION DIAGRAM

<FWD>

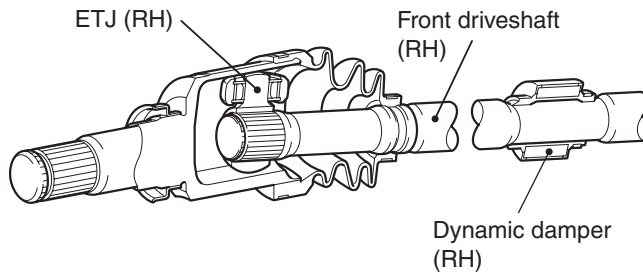
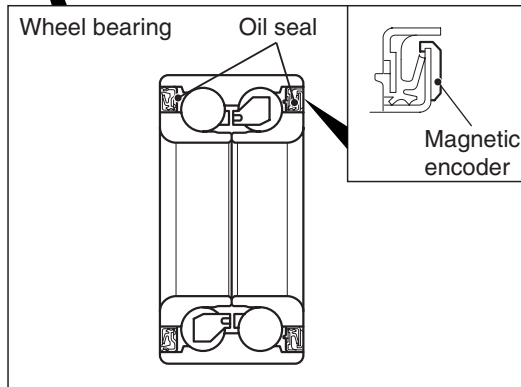
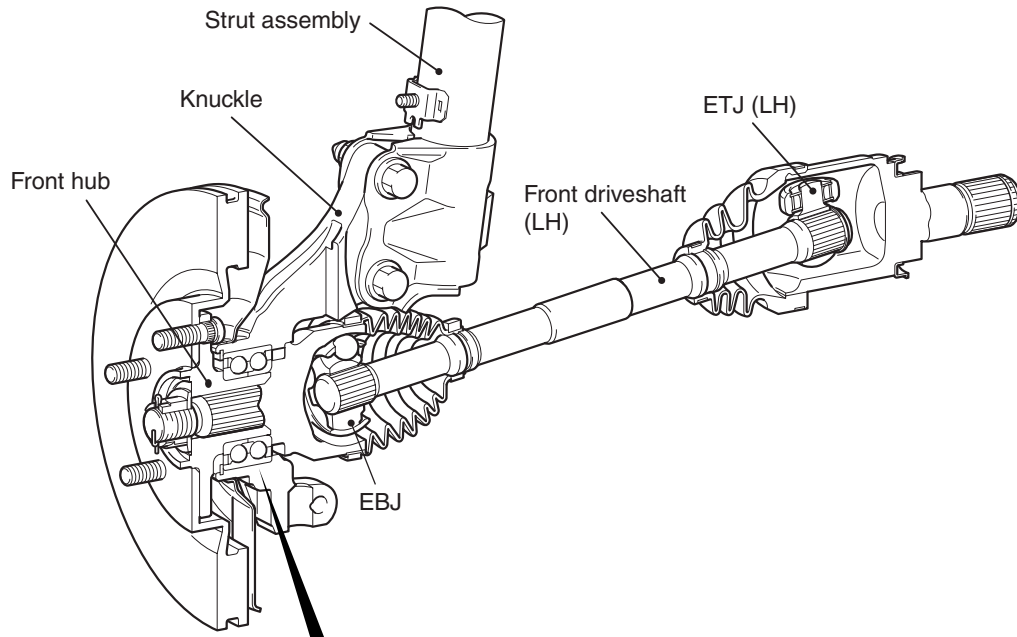

<AWD>

