

---

**GROUP 11B**

**ENGINE  
MECHANICAL  
<2.4L ENGINE>**

**CONTENTS**

**GENERAL DESCRIPTION..... 11B-2    BASE ENGINE ..... 11B-3**

**GENERAL DESCRIPTION**

This model is equipped with a 4B12 engine. It is a 4-cylinder, double overhead camshaft (DOHC) engine with a 2,360 cm<sup>3</sup> cylinder displacement. This engine has adopted the following features:

- MIVEC (MITSUBISHI INNOVATIVE VALVE TIMING ELECTRONIC CONTROL SYSTEM) for both the intake and exhaust valves
- Cylinder block made of an aluminum alloy
- Valve train with direct-acting valve tappets
- Silent timing chain
- Unit type balancer

M2112000102121

**MAIN SPECIFICATIONS**

Item	Specification
Engine model	4B12
Type	In-line, DOHC
Number of cylinders	4
Combustion chamber shape	Pentroof type
Total displacement cm <sup>3</sup> (cu in)	2,360 (144.0)
Cylinder bore mm (in)	88 (3.5)
Piston stroke mm (in)	97 (3.8)
Compression ratio	10.5
Maximum output kW/r/min (HP/r/min)	125/6,000 (168/6,000)
Maximum torque N·m/r/min (ft-lbs/r/min)	226/4,100 (167/4,100)
Fuel injection system type	Electronic control MPI
Ignition system type	Electronic spark-advance control type (4-coil)

## BASE ENGINE

M2112001002116

### CYLINDER HEAD

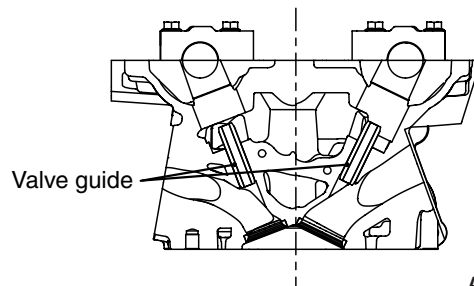
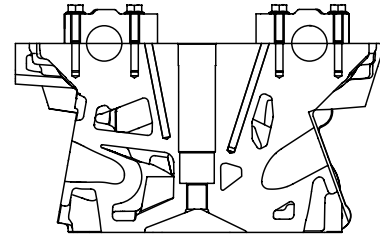
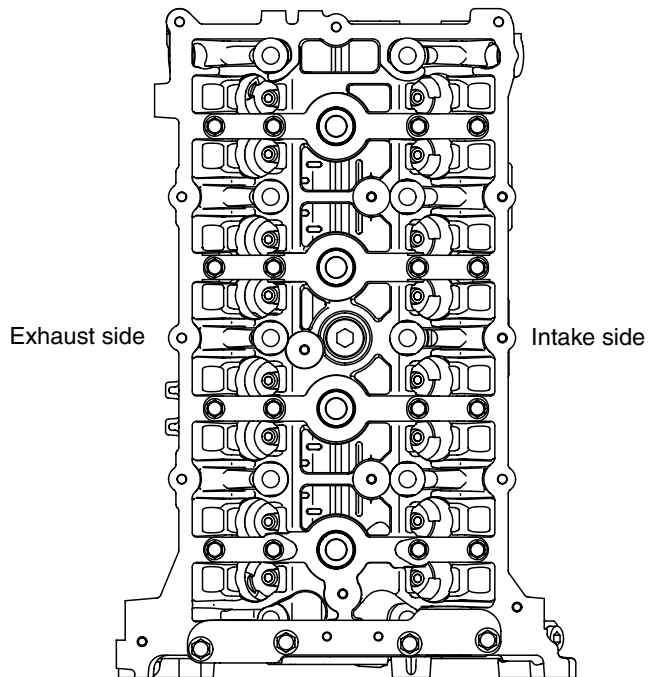

A cylinder head made of an aluminum alloy, which is lightweight and offers a high level of cooling efficiency, has been adopted. A pentroof combustion chamber with a center spark plug has been adopted. It has a small valve compound angle to realize a compact chamber.

Cross-flow type intake and exhaust ports have been adopted. Two intake ports and two exhaust ports are provided independently on the right and left sides. Five camshaft bearings are provided at the intake and exhaust sides, respectively. The No. 4 bearing sustains the thrust load of the camshaft. Only the No. 1 bearing uses a bearing cap that integrates both the intake and exhaust sides.

### VALVE SEATS

Sintered alloy valve seats have been adopted.

The oversized (0.3 mm) service parts are available.

### VALVE GUIDES

Valve guides that are common to both the intake and exhaust have been adopted.

The oversized (0.25 mm) service parts are available.

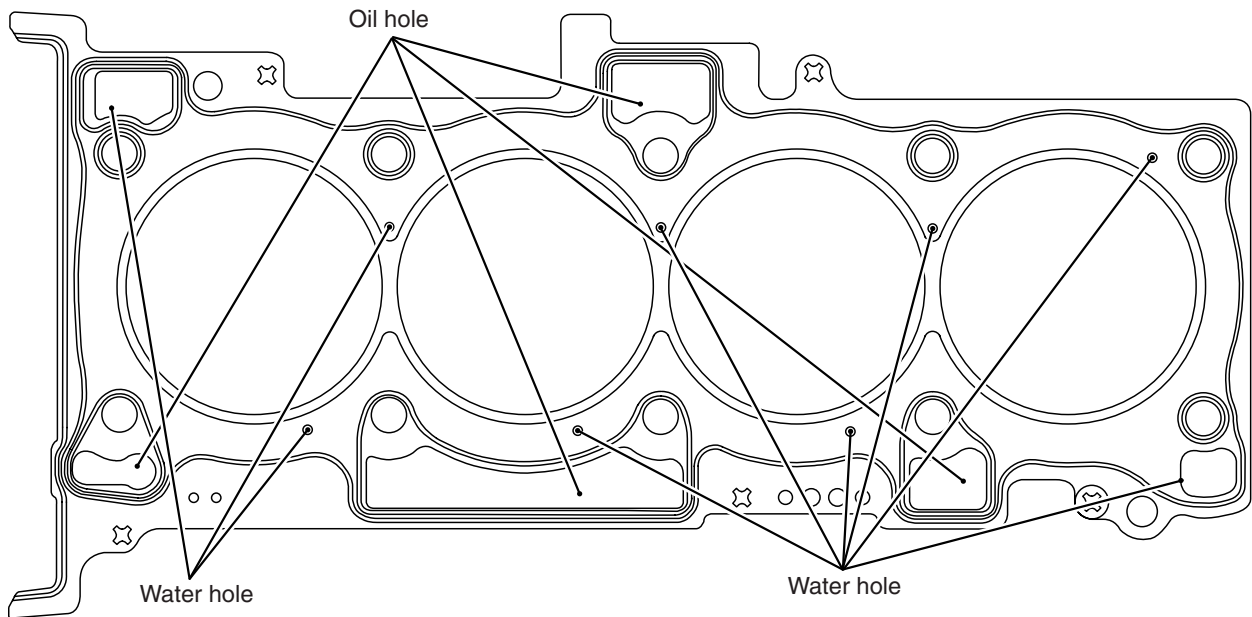
**CYLINDER HEAD GASKET**

AK604543AB

A dual-layer, metal type cylinder head gasket that excels in heat resistance and sealing performance has been adopted.

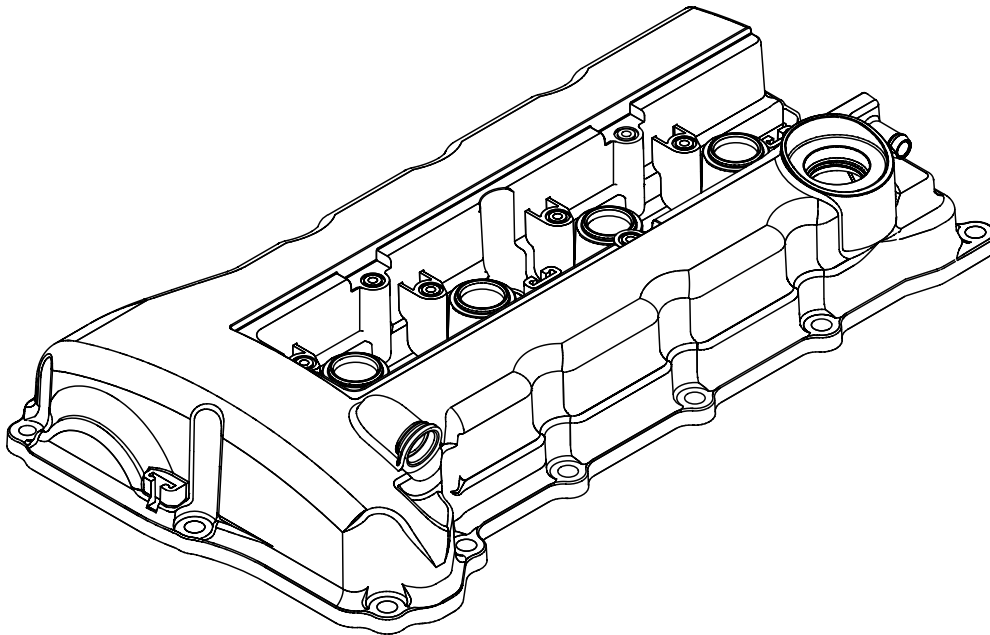
**CYLINDER HEAD COVER**

AK502485

A Plastic cylinder head cover has been adopted.

CYLINDER BLOCK

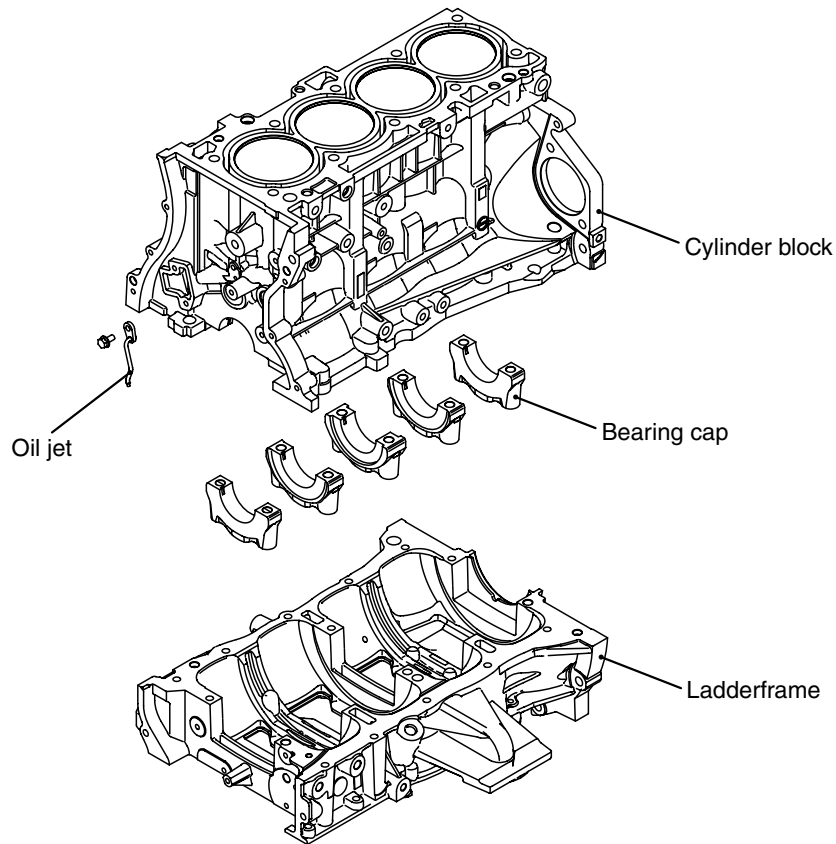

AK502486AE

A cylinder block made of an aluminum alloy has been adopted for weight reduction.  
5 bearings are used for the crankshaft journals and the No. 3 bearing sustains the thrust load of the crankshaft.  
The water jacket is the full Siamese type.  
An oil jet is used in front of the cylinder block to supply engine oil to the timing chain.

Item	Specifications
Distance between top and crankshaft center mm (in)	230.1 (9.06)
Bore mm (in)	88 (3.5)
Bore pitch mm (in)	96 (3.8)
Stroke mm (in)	97 (3.8)

PISTONS

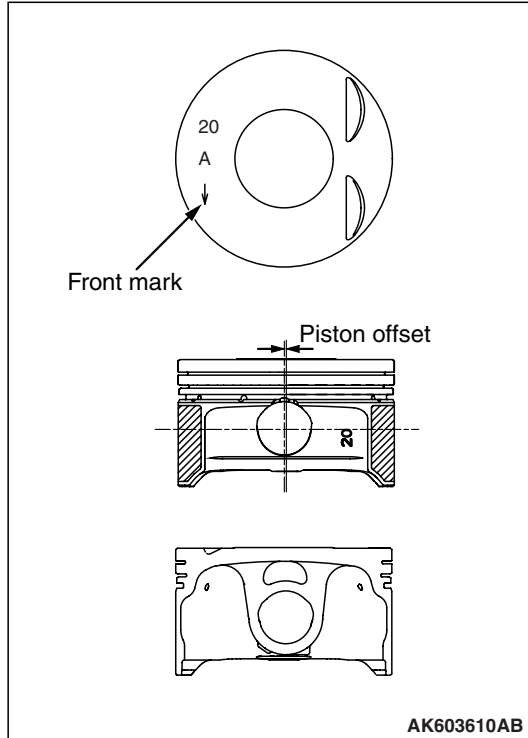

The pistons are made of a special aluminum alloy. Their weight has been reduced by lowering their overall height and increasing the depression at each end of the piston pin. The piston pin hole center is offset 0.8 mm (0.031 in) towards the thrust side of the piston center. The skirt portion along the perimeter of the piston is finished with streaks that excel in oil retention and seizure resistance.

Item	Specifications
Basic diameter mm (in)	88 (3.5)
Pin hole diameter mm (in)	21 (0.8)
Overall height mm (in)	51.5 (2.03)

PISTON PINS

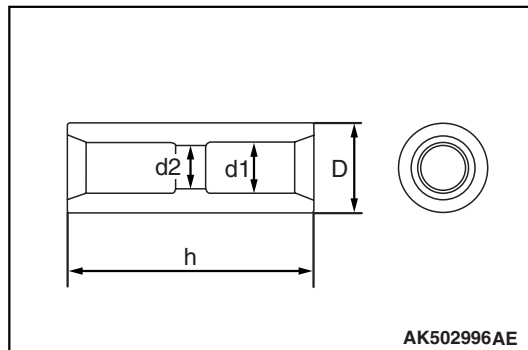

The piston pins are the semi-floating type. Each pin is press-fit and secured in the small end of the connecting rod, while it floats in the piston.

Item	Specifications
Outer diameter (D) mm (in)	21 (0.8)
Inner diameter (d1) mm (in)	12 (0.5)
Inner diameter (d2) mm (in)	10.5 (0.41)
Overall length (h) mm (in)	58 (2.3)

**PISTON RINGS**

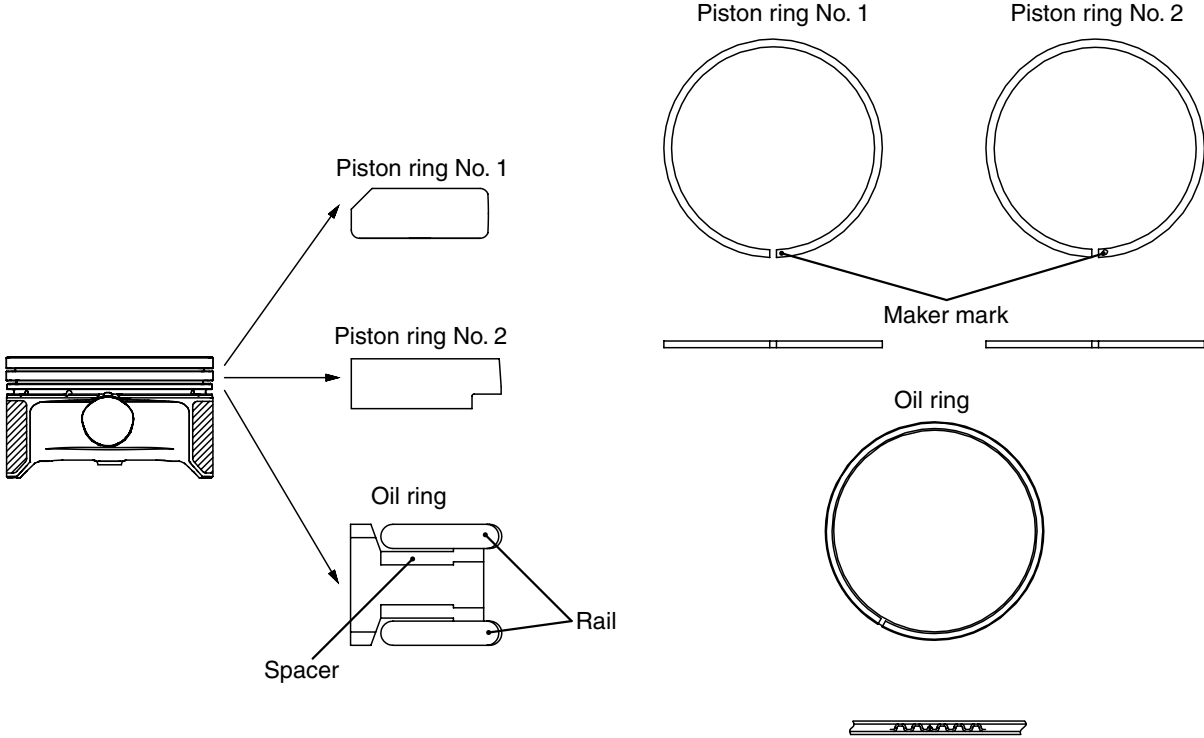

AK604544AB

The piston rings consist of No. 1 and No. 2 rings and an oil ring.

Item	Piston ring No. 1	Piston ring No. 2	Oil ring
Shape	Inside bevel, Barrel	Taper undercut	3-piece, Barrel
Surface treatment (cylinder contact surface)	Chrome plating	Parkerizing	Hard plated Parkerizing
Supplier mark	1T	2T	None

**CONNECTING RODS**

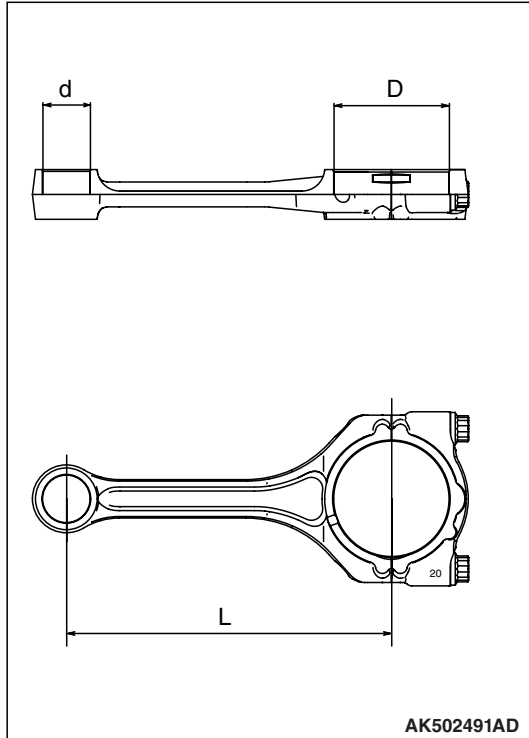

The connecting rods are made of highly rigid, forged carbon steel. The cross section of the rod portion is shaped like the letter H.

A fracture-split process has been adopted for splitting the big end of the connecting rod.

The fracture split connecting rod has the high insertion force between the rod and the cap as well as the high installation location accuracy.

The oil holes that feed oil from the main journals of the crankshaft to the crankshaft pins lubricate the bearings at the big ends of the connecting rods.

Item	Specifications
Small end hole diameter (d) mm (in)	21 (0.87)
Big end hole diameter (D) mm (in)	51 (2.01)
Center-to-center distance (L) mm (in)	143.75 (5.659)

**CONNECTING ROD BEARINGS**

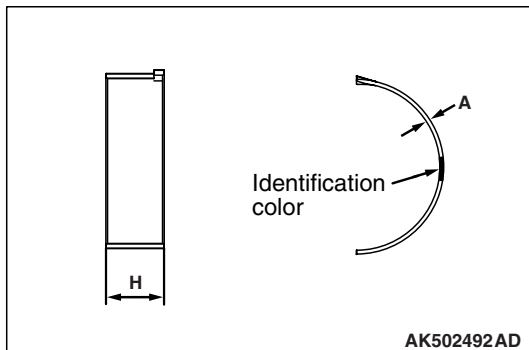

The upper and lower connecting rod bearings are the same. Each connecting rod bearing is provided with a backing plate. Its bearing portion is made of an aluminum alloy and its backing plate is made of ordinary sheet steel.

The width of the connecting rod bearing has been made as narrow as possible in proportion to the bearing cap in order to reduce friction loss.

Item	Specifications
Width (H) mm (in)	17 (0.7)
Thickness (A) mm (in)	1.5 (0.06)



**CRANKSHAFT**

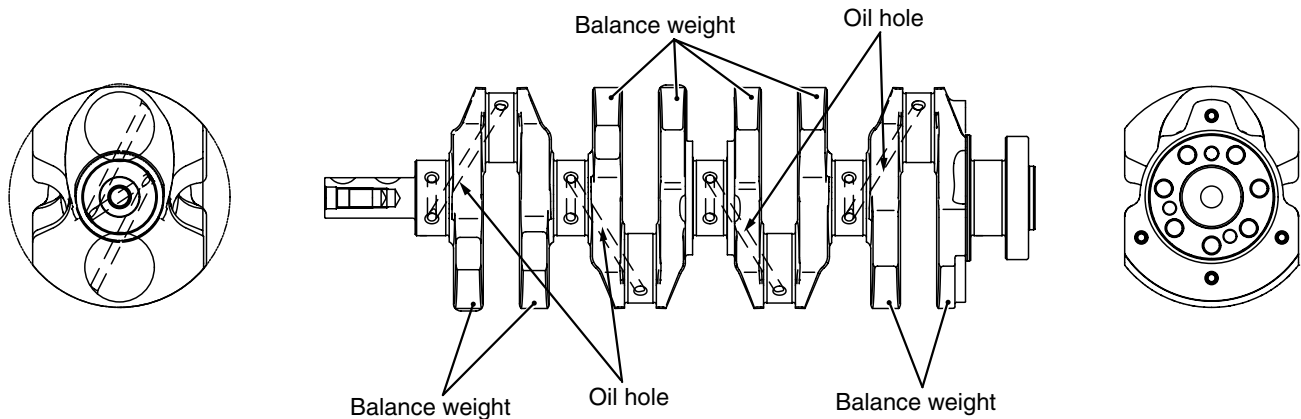

AK502493AD

A forged crankshaft has been adopted. It has 5 main bearings and 8 balance weights. The crankshaft pins are located at equal 180° intervals. The oil holes feed engine oil from the journals to the pins. A crankshaft sprocket and an oil pump drive shaft are press-fit to the front of the crankshaft.

Item	Specifications
Pin outer diameter mm (in)	48 (1.9)
Journal outer diameter mm (in)	52 (2.0)

**CRANKSHAFT BEARINGS, THRUST BEARINGS**

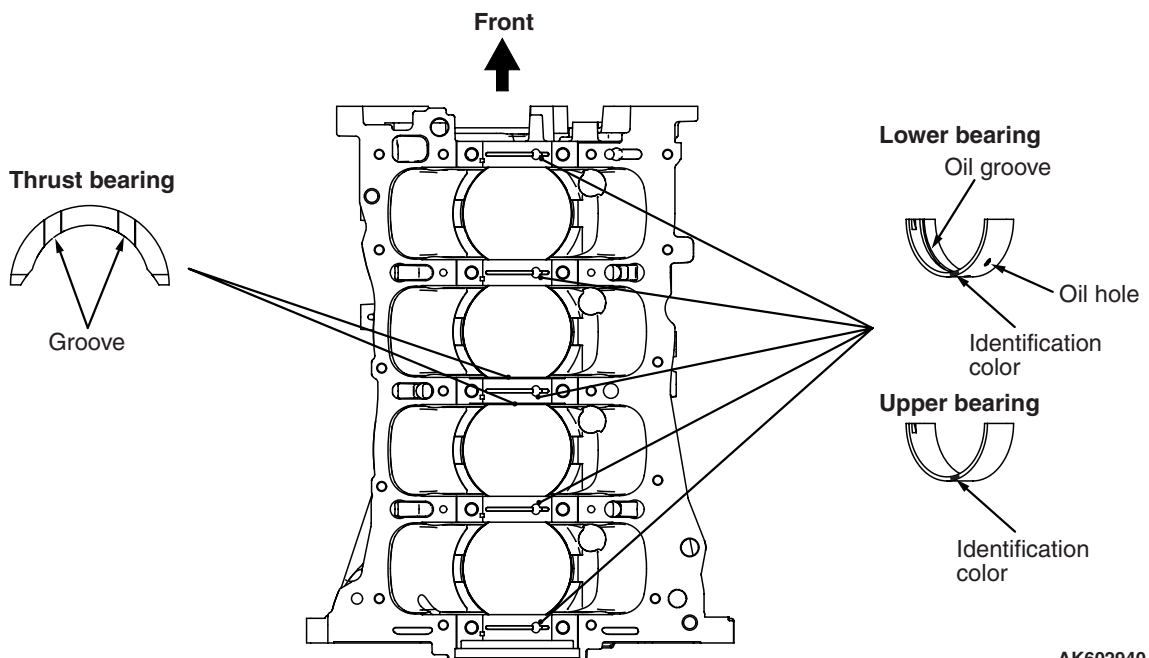

AK602940AC

The upper crankshaft bearings have oil grooves and the lower crankshaft bearings do not.

Each crankshaft bearing is provided with a backing plate. Its bearing portion is made of an aluminum alloy and its backing plate is made of ordinary sheet steel. A thrust bearing, which sustains the load in the thrust direction, is provided at each end of the No. 3 bearing.

Item		Specifications
Crankshaft bearing	Width mm (in)	18 (0.71)
	Thickness mm (in)	2.0 (0.08)
Crankshaft thrust bearing	Thickness mm (in)	1.5 (0.06)

**CRANKSHAFT PULLEY**

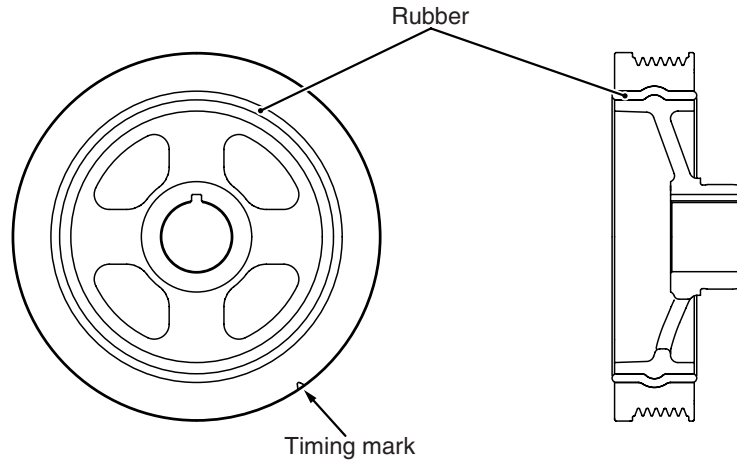

AK604551 AB

The pulley is made of cast iron.  
The pulley portion has grooves for the V-ribbed belt (with 6 crests).  
The flange portion of the pulley has a timing mark notch for checking the ignition timing.

A torsion damper has been adopted to reduce the torsional vibration of the crankshaft, as well as to dramatically reduce noise and vibration in the high-speed range.

## DRIVE PLATE

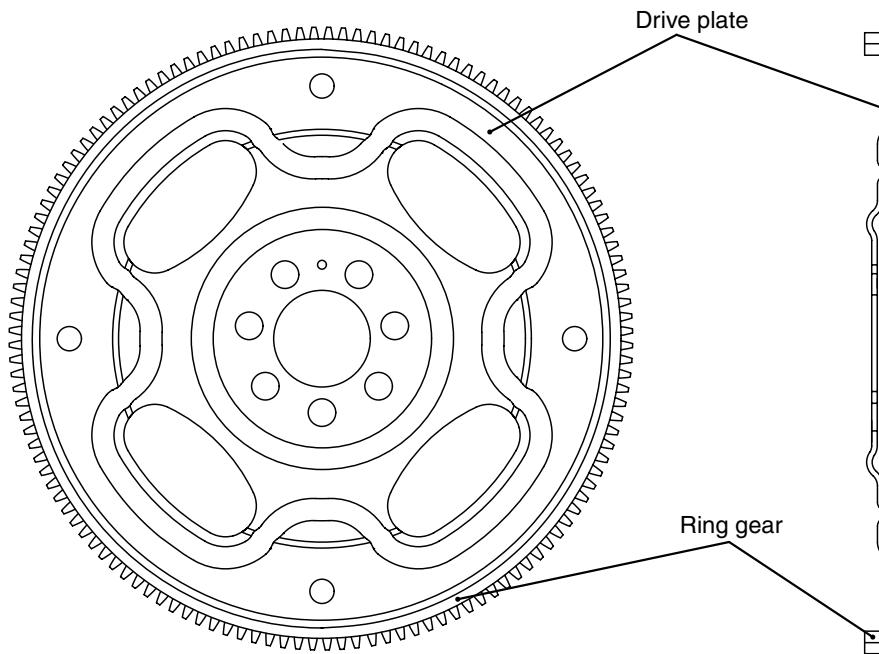

AK502496AD

The drive plate is made of sheet metal.

The drive plate is mounted with 7 bolts.

## FLYWHEEL

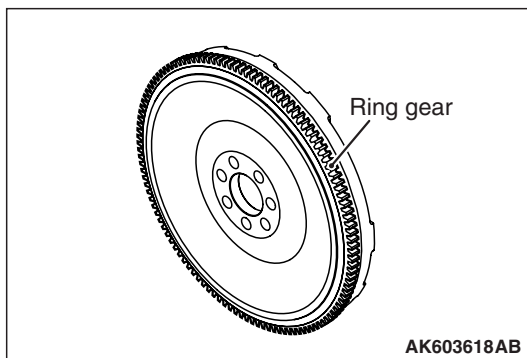

A cast iron ring gear is a shrink fit in the iron casting of the flywheel.

The flywheel is mounted with 7 bolts.

**TIMING CHAIN TRAIN**

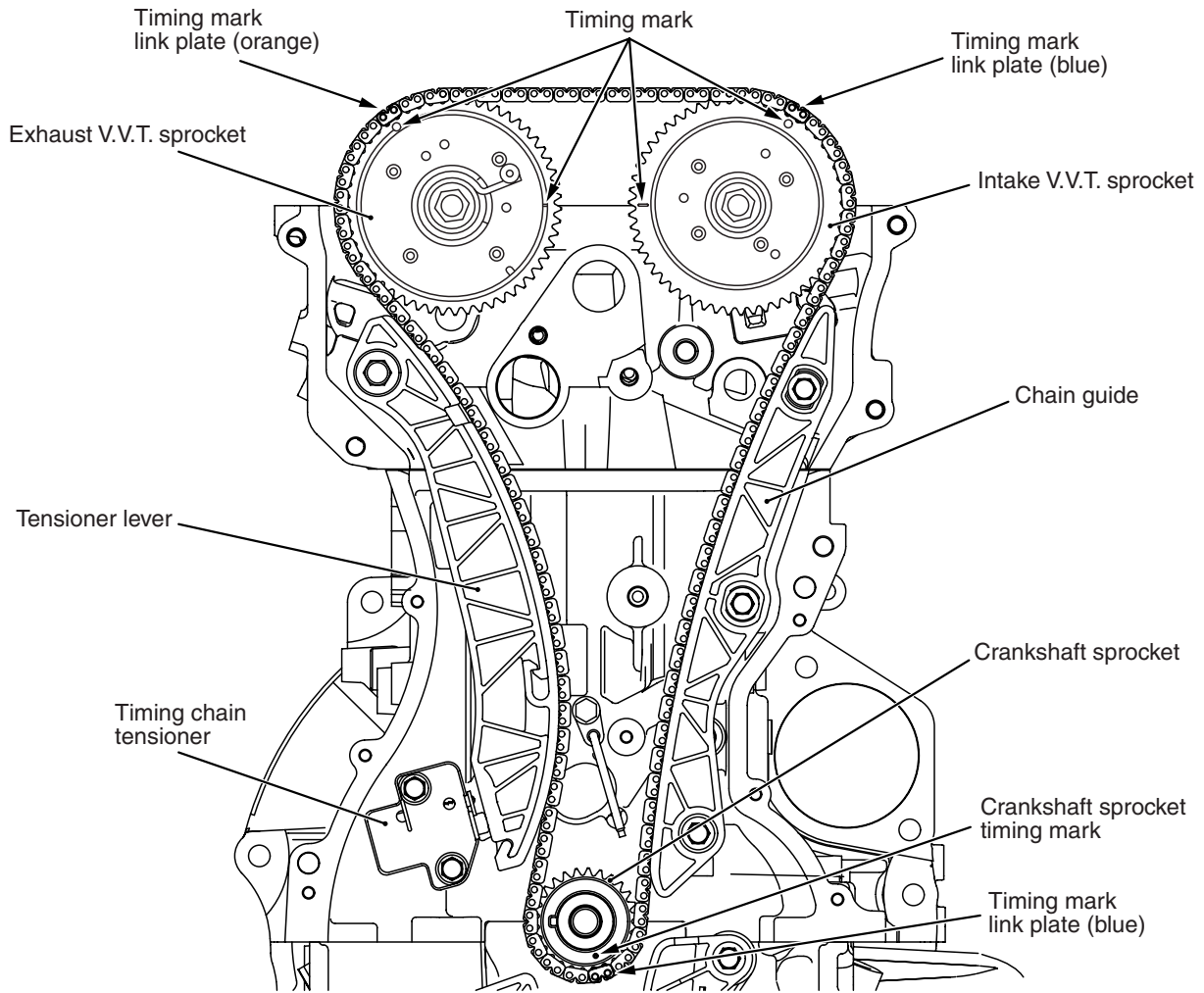

AK502497AP

The two camshafts are driven by the timing chain via the camshaft sprockets.

The timing chain is a silent, endless type, consisting of 180 links. It is installed around the V.V.T. sprockets and the crankshaft sprocket.

Three (orange) mark link plates are installed on the timing chain to locate the sprockets.

Item	Number of teeth
V.V.T. sprockets	54
Crankshaft sprocket	27

**TIMING CHAIN TENSIONER**

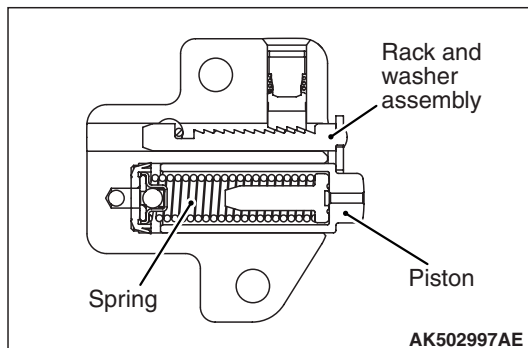

AK502997AE

The tensioner maintains the tension of the timing chain. It contains a piston with a built-in spring. With the tensioner installed, its piston directly pushes on the tension lever in order to automatically adjust the tension of the timing chain.

**VALVE TRAIN**

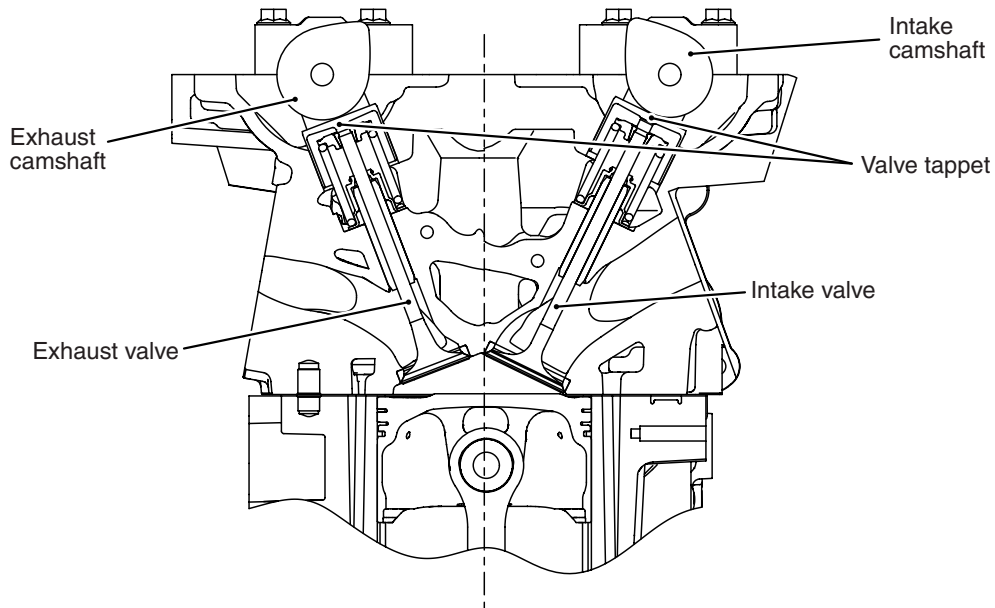

AK502499AD

The valve train is the 4-valve, double overhead camshaft (DOHC) type in which the camshafts are located above the valves. Two intake and exhaust valves for each cylinder are arranged in a V shape.

A valve tappet is interposed between the camshaft and each valve, which allows the valve to open and close.

**VALVES**

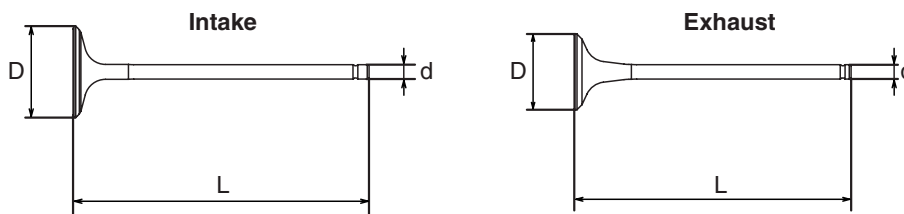

AK502500AD

The valves are made of heat-resistant steel and are nitrided on their entire surface.

Item	Intake valve	Exhaust valve
Head diameter (D) mm (in)	35 (1.4)	29 (1.1)
Stem diameter (d) mm (in)	5.5 (0.22)	5.5 (0.22)
Overall length (L) mm (in)	113.180 (4.4559)	105.887 (4.1688)

**VALVE STEM SEALS**

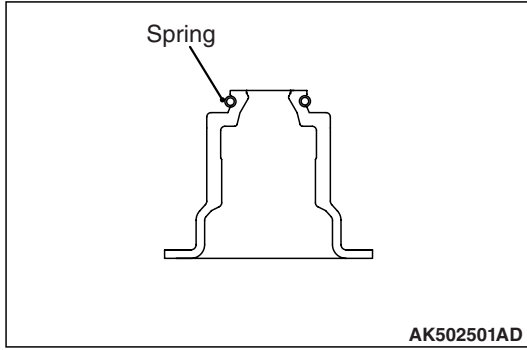

The valve stem seals are integrated with the valve spring seats. The valve stem seal portion excels in sealing performance and is equipped with a spring to prevent oil from descending.

**VALVE SPRINGS**

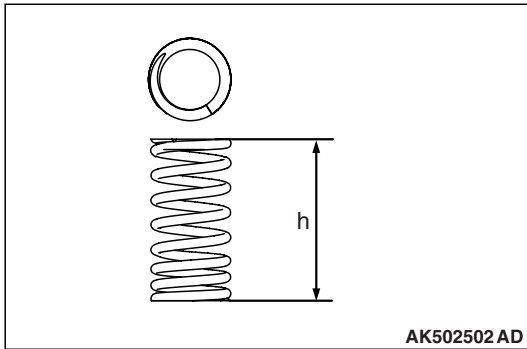

To prevent the engine from surging at high speeds, unequal-pitch springs are used.

Item	Specifications
Free height (h) mm (in)	47.2 (1.858)
Total number of windings	8.23

**VALVE TAPPETS**

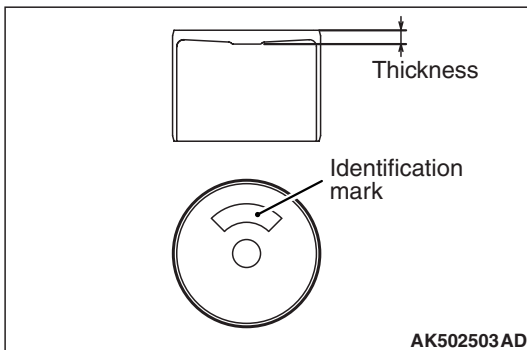

To adjust the valve lift, 47 sizes of valve tappets are available in 0.015 mm (0.0006 in) increments, from 3.000 mm (0.1181 inch) to 3.690 mm (0.1453 in).

**MIVEC (MITSUBISHI INNOVATIVE VALVE TIMING ELECTRONIC CONTROL SYSTEM)**

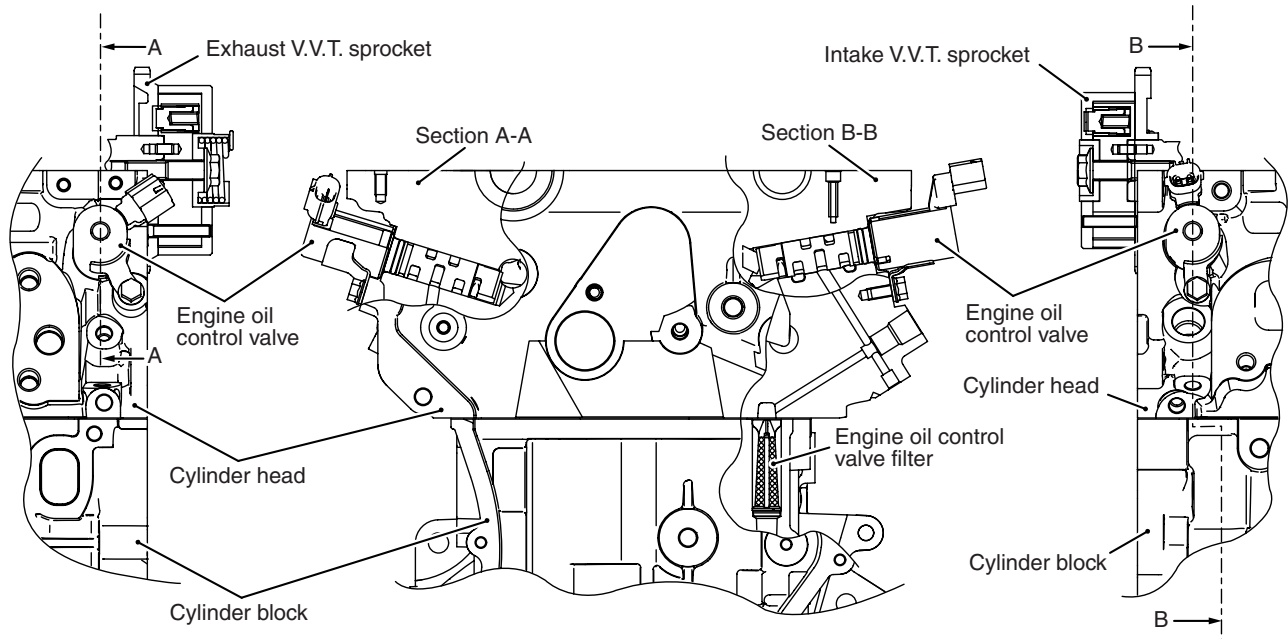

AK503014AE

The MIVEC consists of the parts shown in the illustration.

This system continuously varies and optimally controls the opening and closing timing of the individual intake and exhaust valves, in order to improve torque and power output in all speed ranges.

**V.V.T. SPROCKET (VARIABLE VALVE TIMING SPROCKET)**

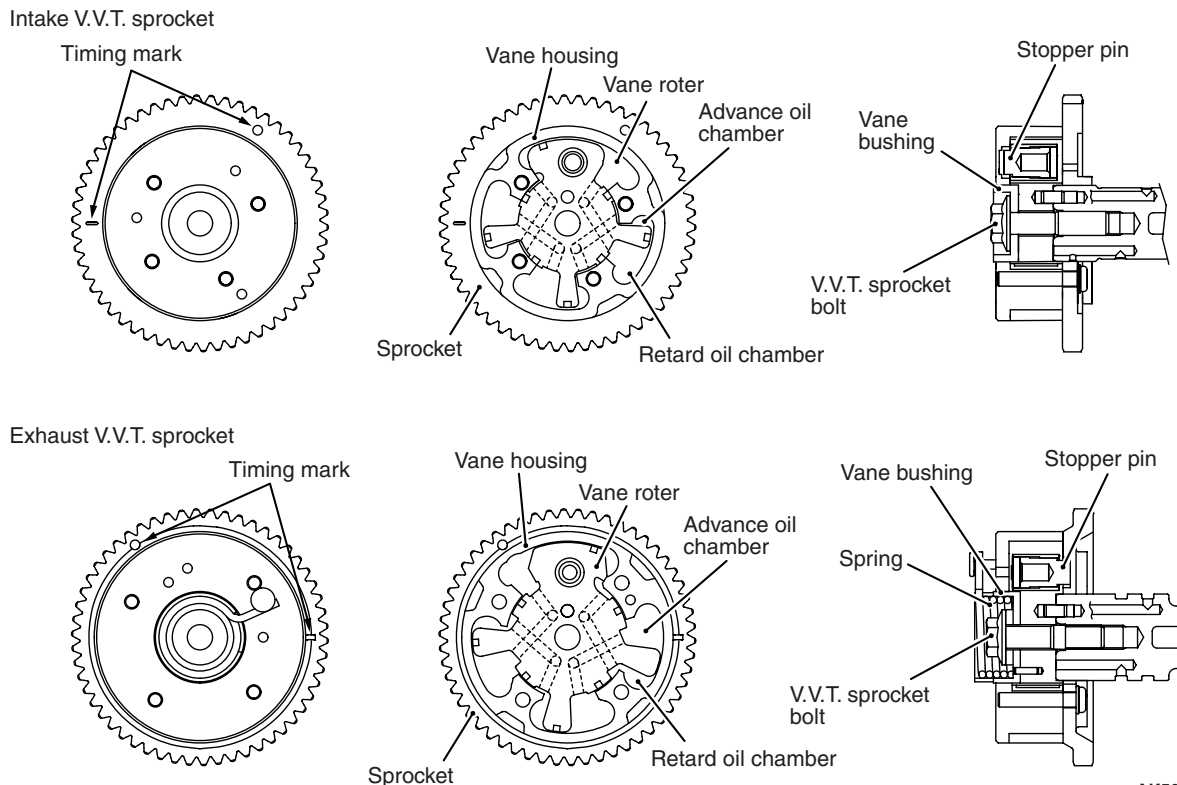

AK503061AD

The engine oil control valve controls the hydraulic pressure in order to move the vane rotor in the V.V.T.

sprocket to optimally control valve timing.

CAMSHAFT

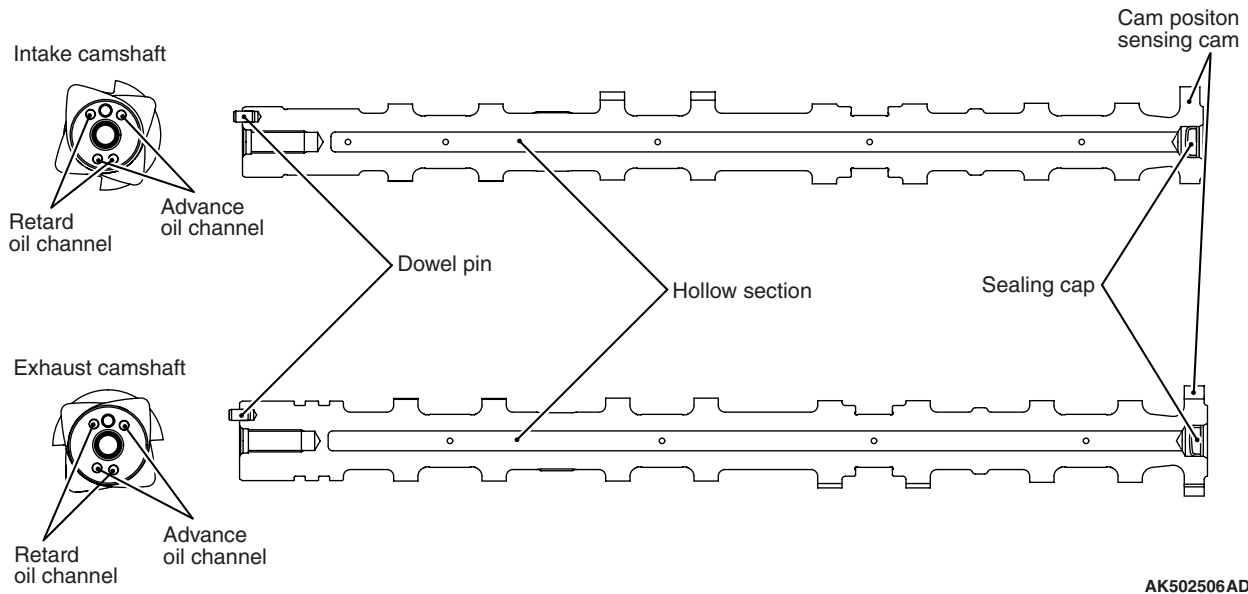

The camshaft are hollow for weight reduction. Each camshaft is provided with an oil passage to guide the hydraulic pressure from the engine oil control valve to the V.V.T. sprocket.

A cam position sensing cam for detecting the cam position (used by the cam position sensor) is integrated at the back of each camshaft.

Item		Specifications	
Overall length mm (in)	Intake	435.00 (17.126)	
	Exhaust	438.27 (17.255)	
Journal outer diameter mm (in)	Intake	No.1	30 (1.2)
		No.2 -5	24 (0.9)
	Exhaust	No.1	36 (1.4)
		No.2 -5	24 (0.9)
Camshaft lift mm (in)	Intake	9.3 (0.37)	
	Exhaust	8.2 (0.32)	



## ENGINE OIL CONTROL VALVE

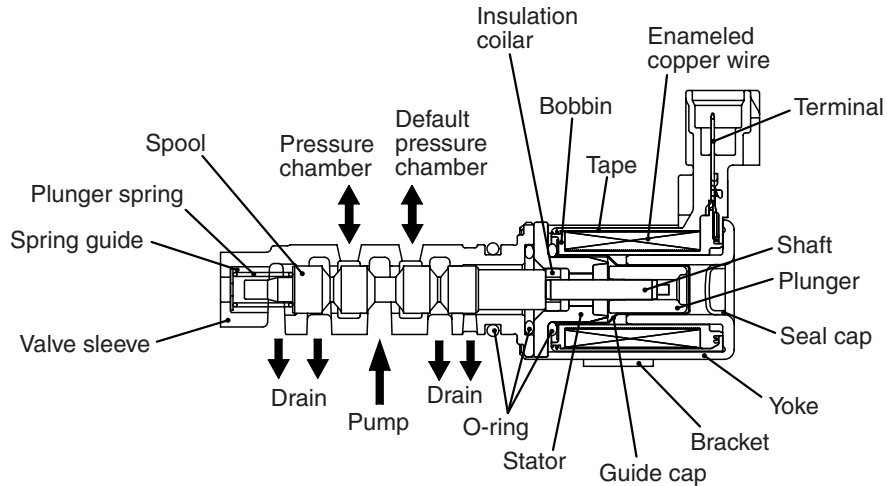

AK302997AE

The engine oil control valve consists of a solenoid valve, which switches the hydraulic pressure that acts on the vane rotor in the V.V.T. sprocket assembly. This valve is actuated by a signal from the engine ECU.

## TIMING CHAIN CASE

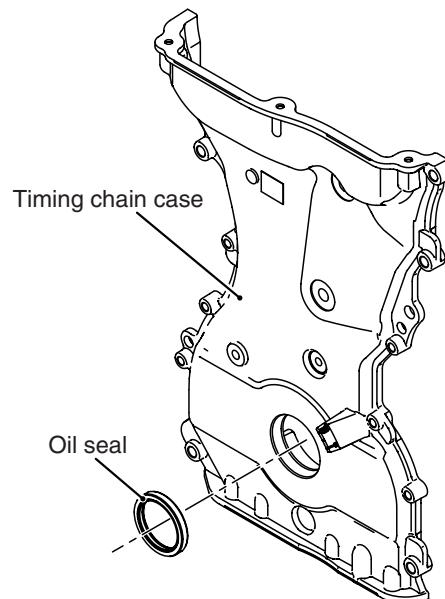

AK502507AD

The timing chain case is made of an aluminum alloy. A front crankshaft oil seal is press-fit into the case.

BALANCER SHAFT MODULE ASSEMBLY

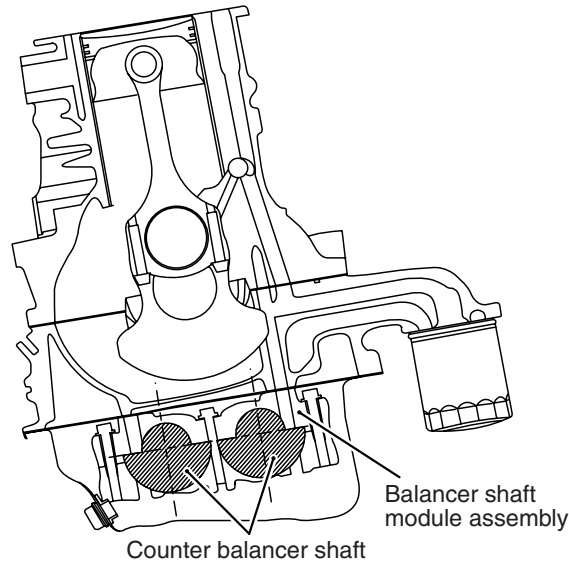

AK802150 AB

The counter balancer shaft is located inside the oil pan to achieve a compact engine.

Items	Specifications
Effectiveness	Vertical vibromotive force

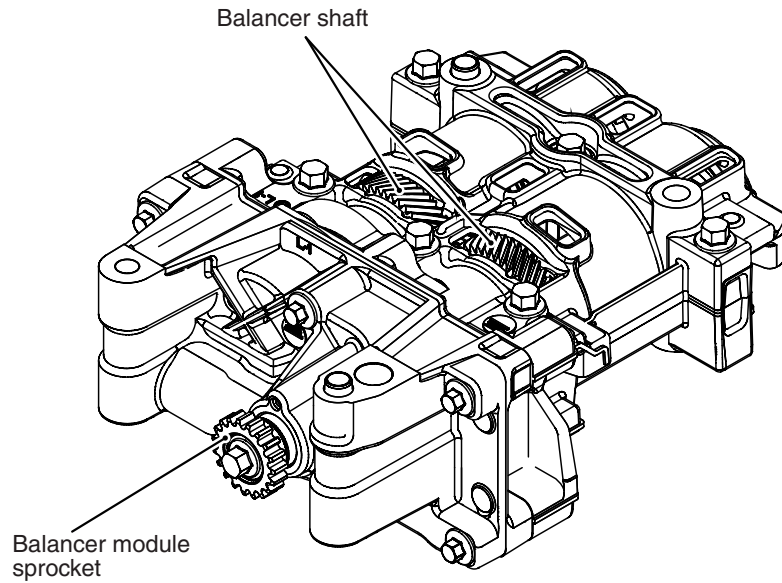

AK502509AE

The balancer shaft module assembly integrates an oil pump and a balancer unit to realize a compact and lightweight package.

The balancer shaft module assembly cannot be disassembled.

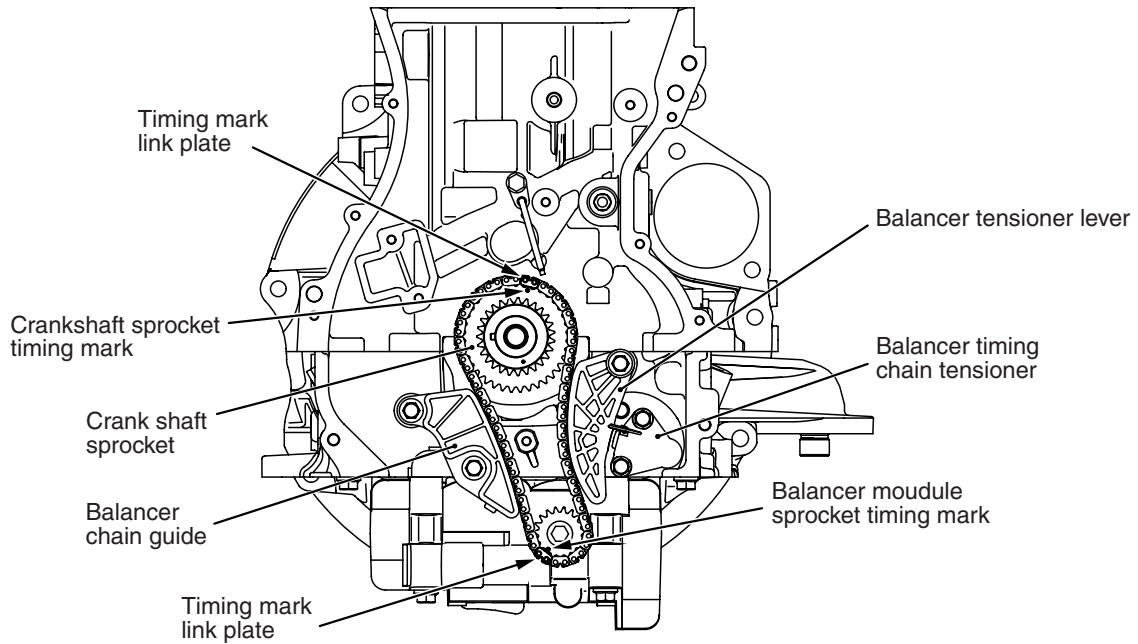

AK502508AI

The balancer chain is a silent, endless type, consisting of 72 links. It is installed around the balancer module sprocket and the crankshaft sprocket. Two mark link plates (orange and blue) are installed on the balancer chain to locate the sprockets. When the balancer chain drives the balancer module sprocket, the balancer gear causes the right and left balancer shafts to rotate.

Item	Number of teeth
Crankshaft sprocket	38
Balancer module sprocket	19

---

## NOTES