

---

**GROUP 14**

**ENGINE COOLING**

**CONTENTS**

**GENERAL INFORMATION ..... 14-2**    **WATER PUMP ..... 14-6**  
**WATER PASSAGE ..... 14-5**

## GENERAL INFORMATION

M2140000101363

For the cooling system, in addition to the adoption of forced water-cooling circulation method to satisfy the engine cooling performance, a consideration has been given to its serviceability.

- The radiator fan diameter has been increased, and the condenser fan has been mounted to the back of radiator to increase the fan air volume and to improve the cooling performance.
- A cross flow type radiator has been adopted and the radiator core size has been increased to improve the cooling performance.
- Together with an adoption of resin cooling fan shroud, the radiator fan shroud and condenser fan shroud have been integrated for a weight reduction.

## SPECIFICATIONS

Item		2.0L Engine	2.4L Engine
Cooling method		Water-cooled pressurized, forced circulation with electrical fan	
Water pump	Type	Centrifugal impeller	
	Drive method	Drive belt	
Thermostat	Type	Wax pellet with jiggle valve	
	Valve open temperature °C (°F)	76.5 (170)	82 (180)
Radiator	Type	Pressurized corrugate type	
	Core size [width × height × thickness] mm (in)	700 × 403.3 × 27 (27.56 × 15.88 × 1.06)	700 × 408.6 × 16 (27.56 × 16.09 × 0.6)
	Performance kJ/h (kcal/h)	254,000 (60,677)	222,600 (53,189)
Radiator fan	Fan size mm (in)	φ340 (13.4)	
Condenser fan	Fan size mm (in)	φ320 (12.6)	

<2.0L ENGINE>

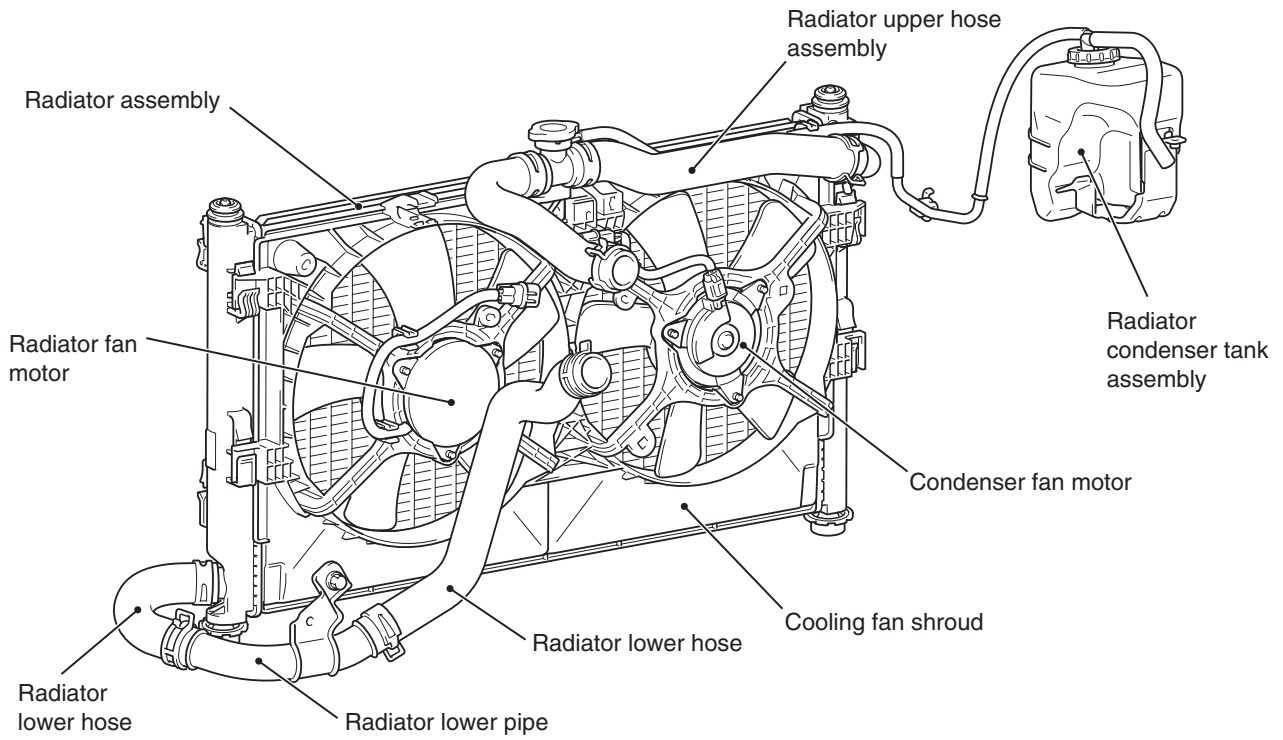

AC705530AE

<2.4L ENGINE>

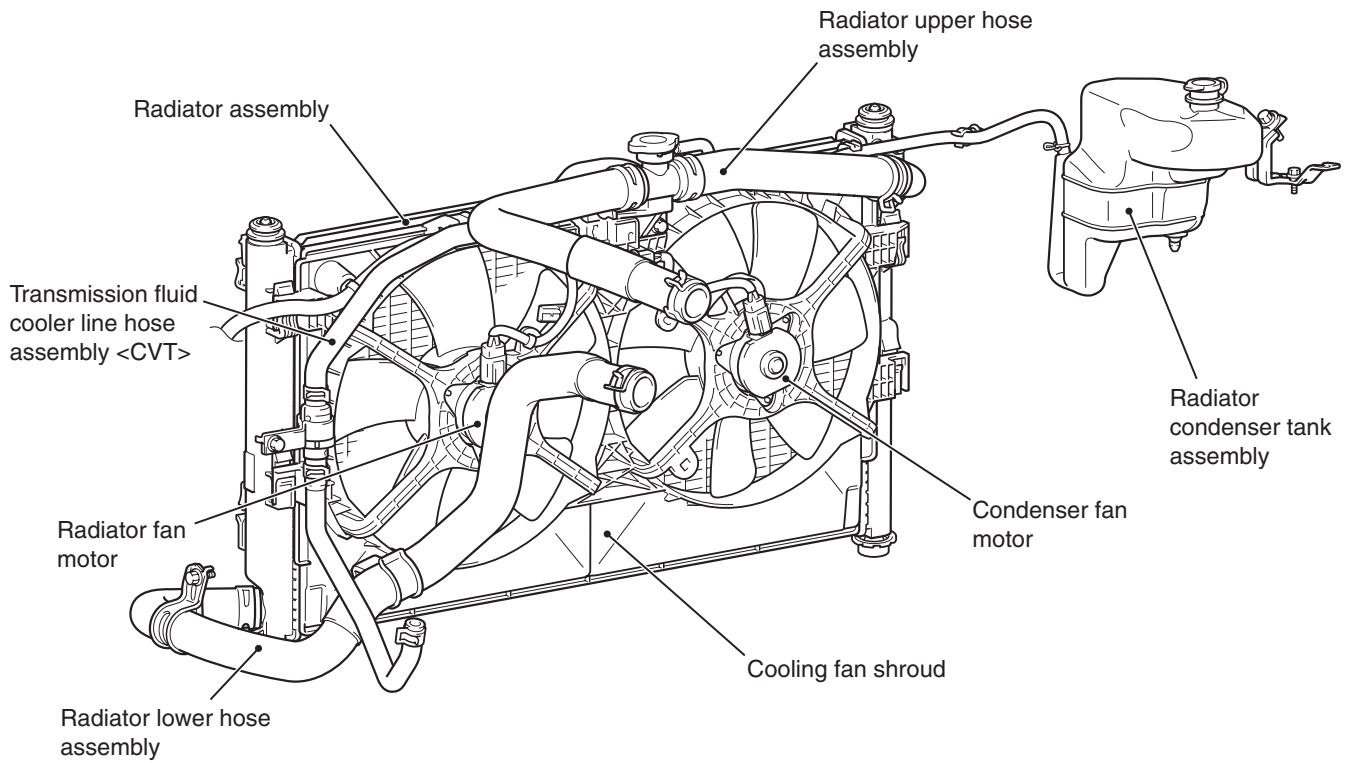

# WATER PASSAGE

M2140004000600

## <2.0L ENGINE>

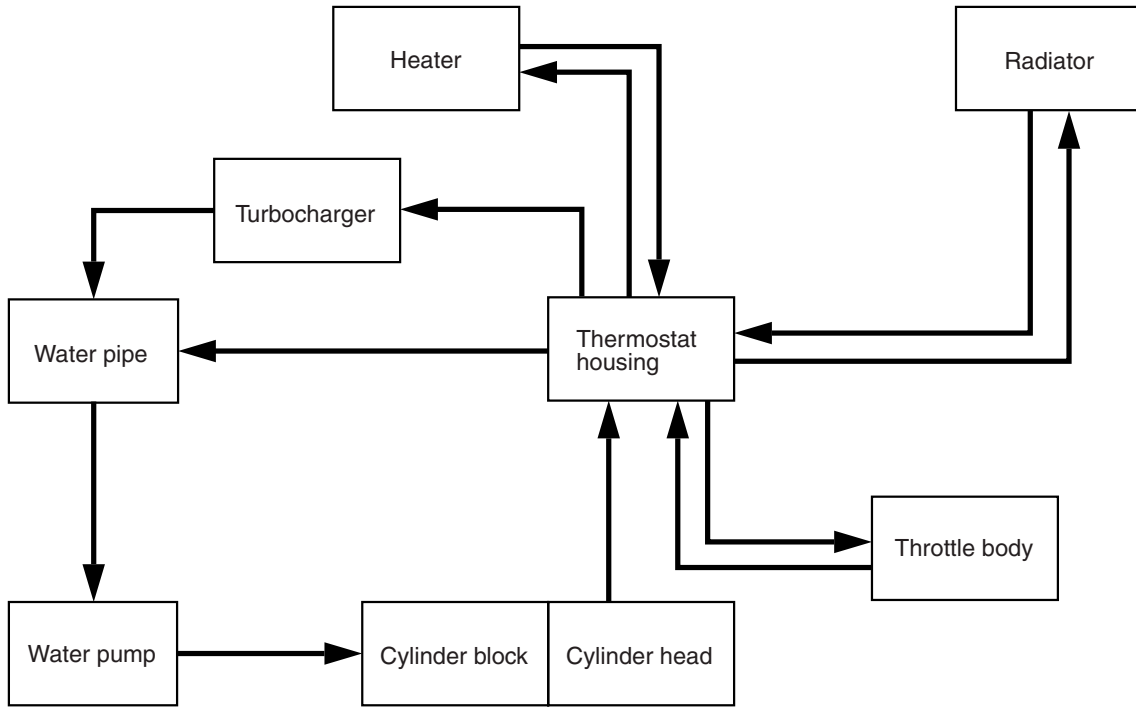

AK703252AC

## <2.4L ENGINE>

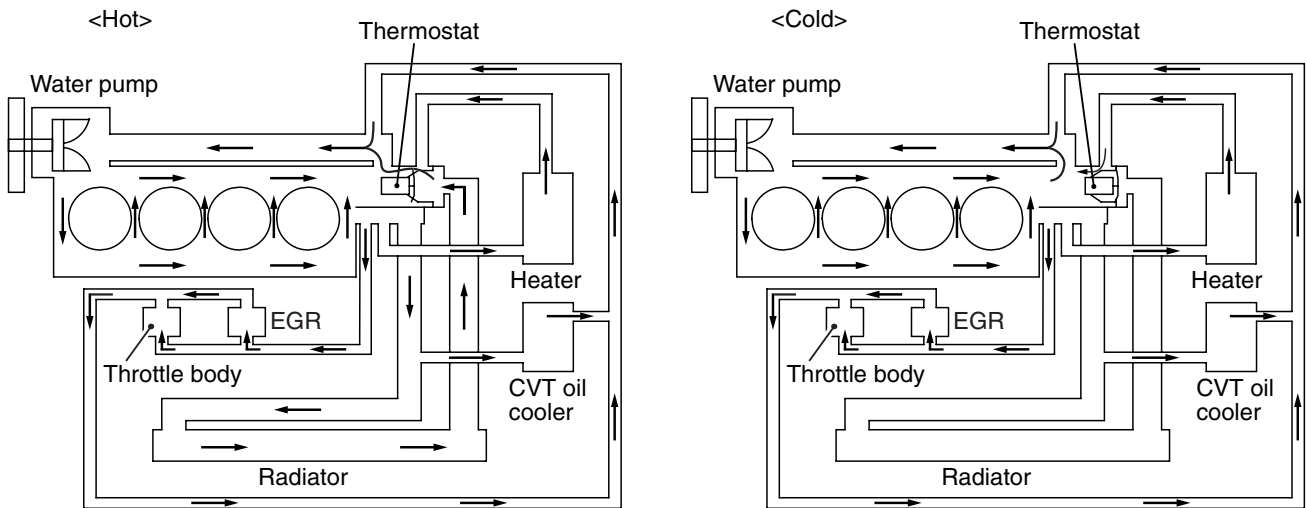

AK603624AB

**WATER PUMP**

M2140003000317

The water pump is the centrifugal, impeller type that is installed in front of the cylinder block. It is driven by the drive belt.

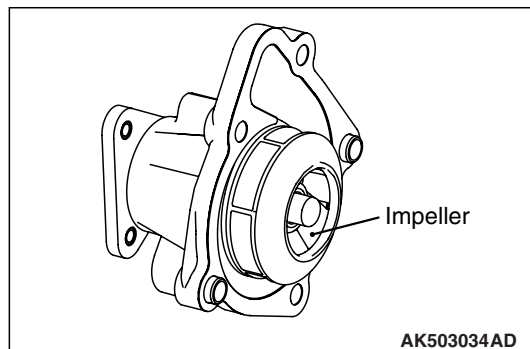

Item	Specifications
Discharge volume L/min dm <sup>3</sup> (qt)	185 (195)
Impeller diameter mm (in)	62 (2.4)
Pulley outer diameter mm (in)	137 (5.4)