

## GROUP 13B

# MULTIPOINT FUEL SYSTEM (MFI) <2.4L ENGINE>

## CONTENTS

GENERAL DESCRIPTION.....	13B-2	HEATED OXYGEN SENSOR HEATER CONTROL.....	13B-48
CONTROL UNIT.....	13B-5	A/C COMPRESSOR CLUTCH RELAY CONTROL.....	13B-49
SENSOR.....	13B-7	GENERATOR CONTROL.....	13B-50
ACTUATOR.....	13B-24	EVAPORATIVE EMISSION PURGE CONTROL.....	13B-51
FUEL INJECTION CONTROL.....	13B-31	EVAPORATIVE EMISSION CONTROL SYSTEM INCORRECT PURGE FLOW MONITOR.....	13B-51
IGNITION TIMING AND CONTROL FOR CURRENT CARRYING TIME.....	13B-36	EXHAUST GAS RECIRCULATION CONTROL.....	13B-52
THROTTLE VALVE OPENING ANGLE CONTROL AND IDLE SPEED CONTROL.....	13B-39	CONTROLLER AREA NETWORK (CAN).....	13B-52
MIVEC (Mitsubishi Innovative Valve Timing Electronic Control System).....	13B-41	HC TRAP CATALYTIC CONVERTER DETERIORATION MONITOR.....	13B-52
MULTIPOINT FUEL INJECTION (MFI) RELAY CONTROL.....	13B-44	ON-BOARD DIAGNOSTICS.....	13B-53
FUEL PUMP RELAY CONTROL....	13B-45		
STARTER RELAY CONTROL.....	13B-46		

# GENERAL DESCRIPTION

M2132000102491

The control system of the 2.4L engine mounted on the 2010 LANCER SPORTBACK has the following structure. This control system is the same as that of the 2.4L engine mounted on the conventional LANCER.

## System Block Diagram

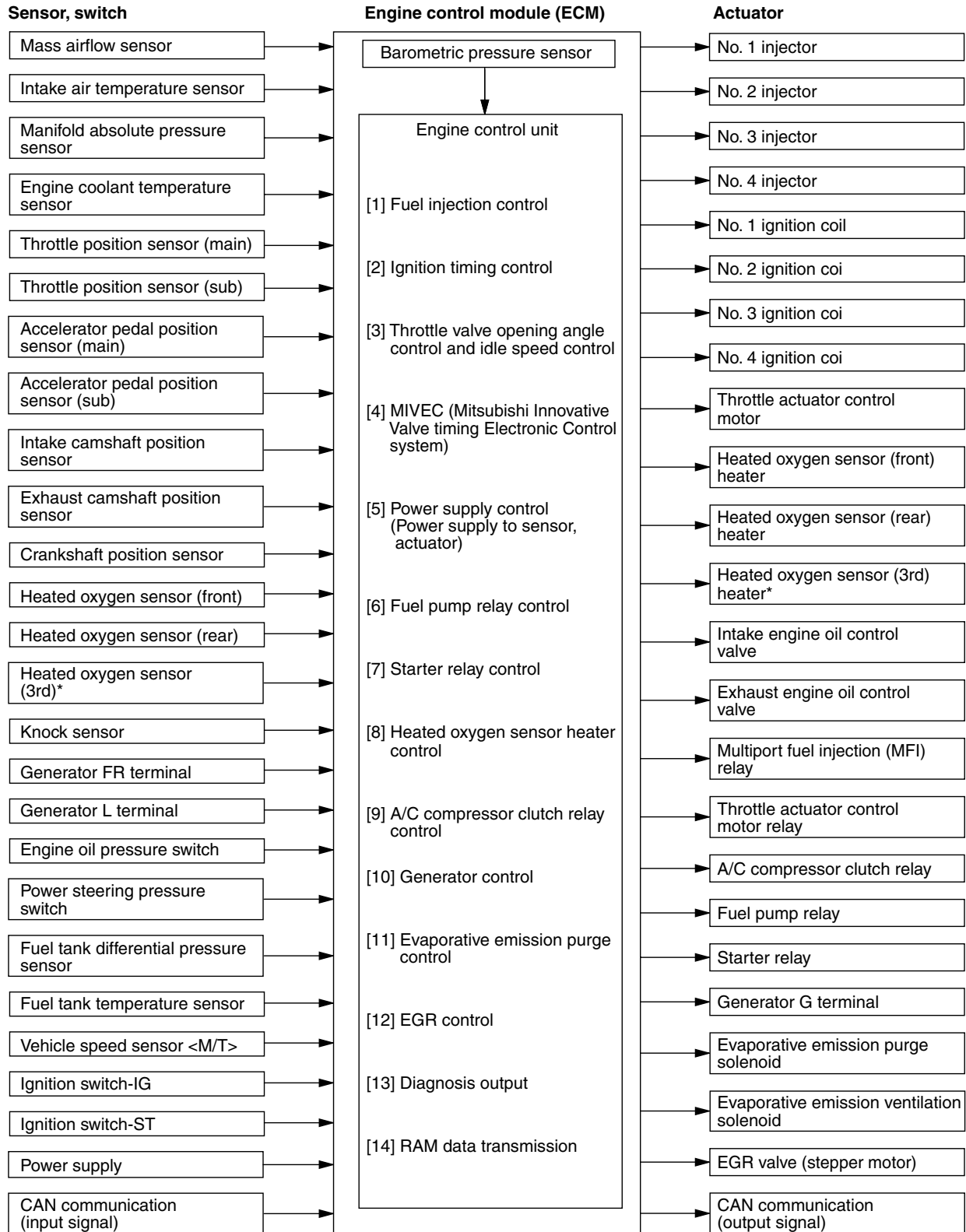

NOTE  
\*: Vehicles for California

Control System Diagram

<Except vehicles for California>

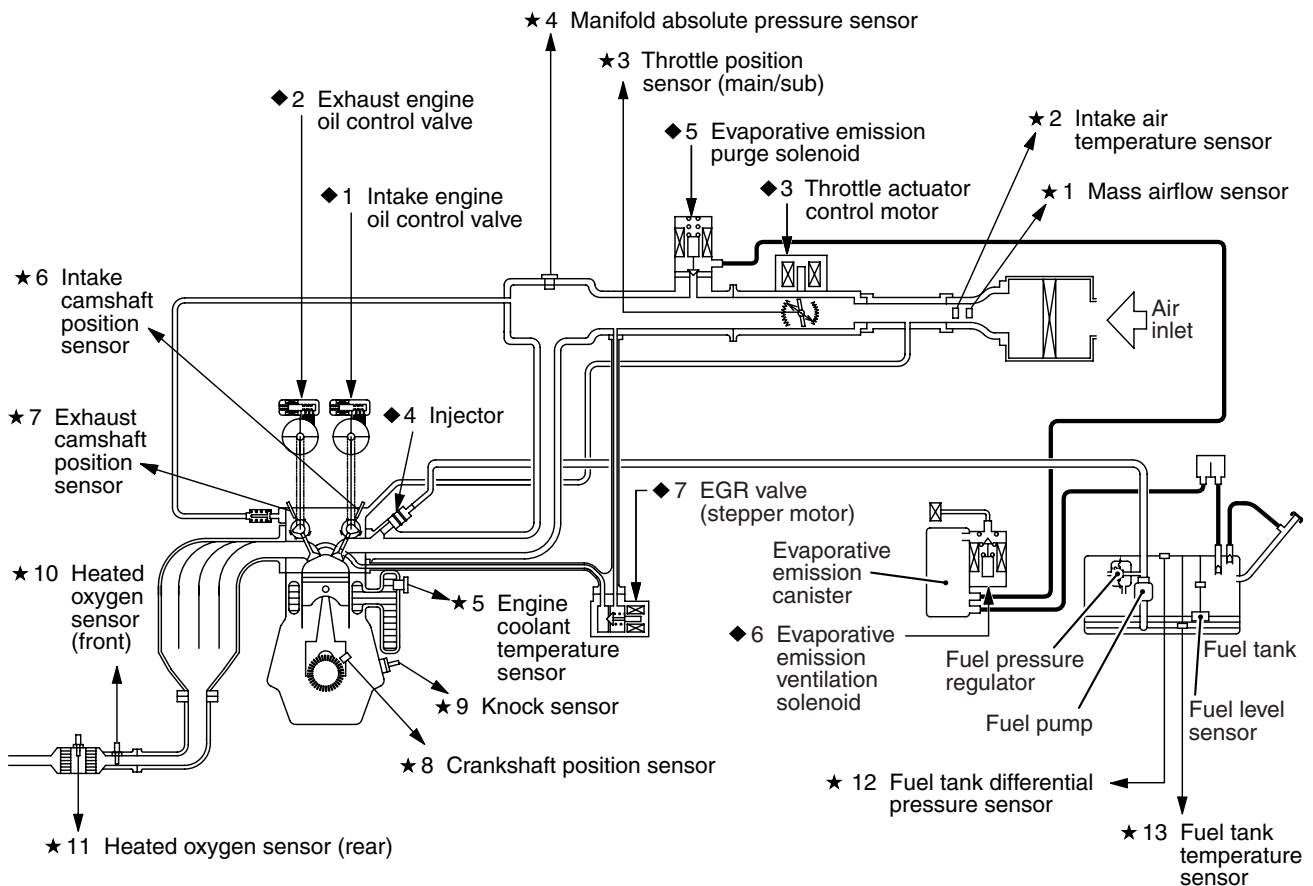
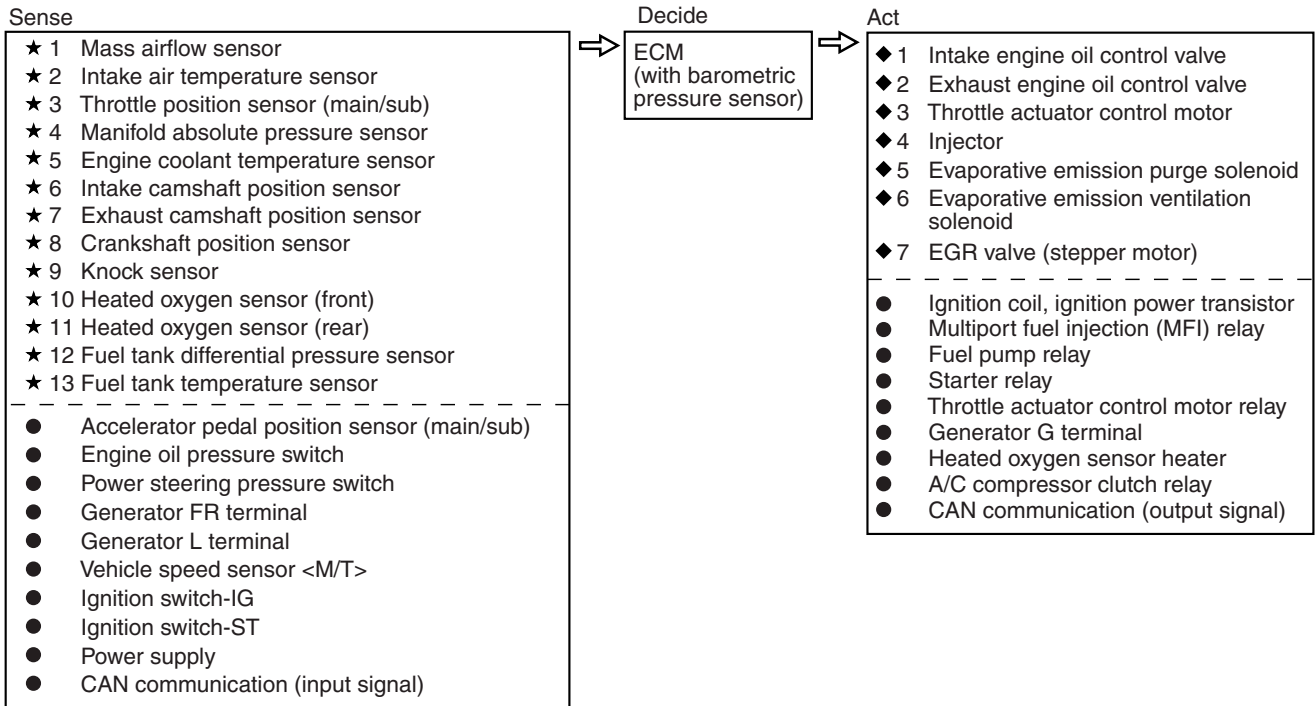

<Vehicles for California>

Sense

- ★1 Mass airflow sensor
  - ★2 Intake air temperature sensor
  - ★3 Throttle position sensor (main/sub)
  - ★4 Manifold absolute pressure sensor
  - ★5 Engine coolant temperature sensor
  - ★6 Intake camshaft position sensor
  - ★7 Exhaust camshaft position sensor
  - ★8 Crankshaft position sensor
  - ★9 Knock sensor
  - ★10 Heated oxygen sensor (front)
  - ★11 Heated oxygen sensor (rear)
  - ★12 Heated oxygen sensor (3rd)
  - ★13 Fuel tank differential pressure sensor
  - ★14 Fuel tank temperature sensor
- 
- Accelerator pedal position sensor (main/sub)
  - Engine oil pressure switch
  - Power steering pressure switch
  - Generator FR terminal
  - Generator L terminal
  - Vehicle speed sensor <M/T>
  - Ignition switch-IG
  - Ignition switch-ST
  - Power supply
  - CAN communication (input signal)

Decide

ECM  
(with barometric pressure sensor)

Act

- ◆1 Intake engine oil control valve
  - ◆2 Exhaust engine oil control valve
  - ◆3 Throttle actuator control motor
  - ◆4 Injector
  - ◆5 Evaporative emission purge solenoid
  - ◆6 Evaporative emission ventilation solenoid
  - ◆7 EGR valve (stepper motor)
- 
- Ignition coil, ignition power transistor
  - Multipoint fuel injection (MFI) relay
  - Fuel pump relay
  - Starter relay
  - Throttle actuator control motor relay
  - Generator G terminal
  - Heated oxygen sensor heater
  - A/C compressor clutch relay
  - CAN communication (output signal)

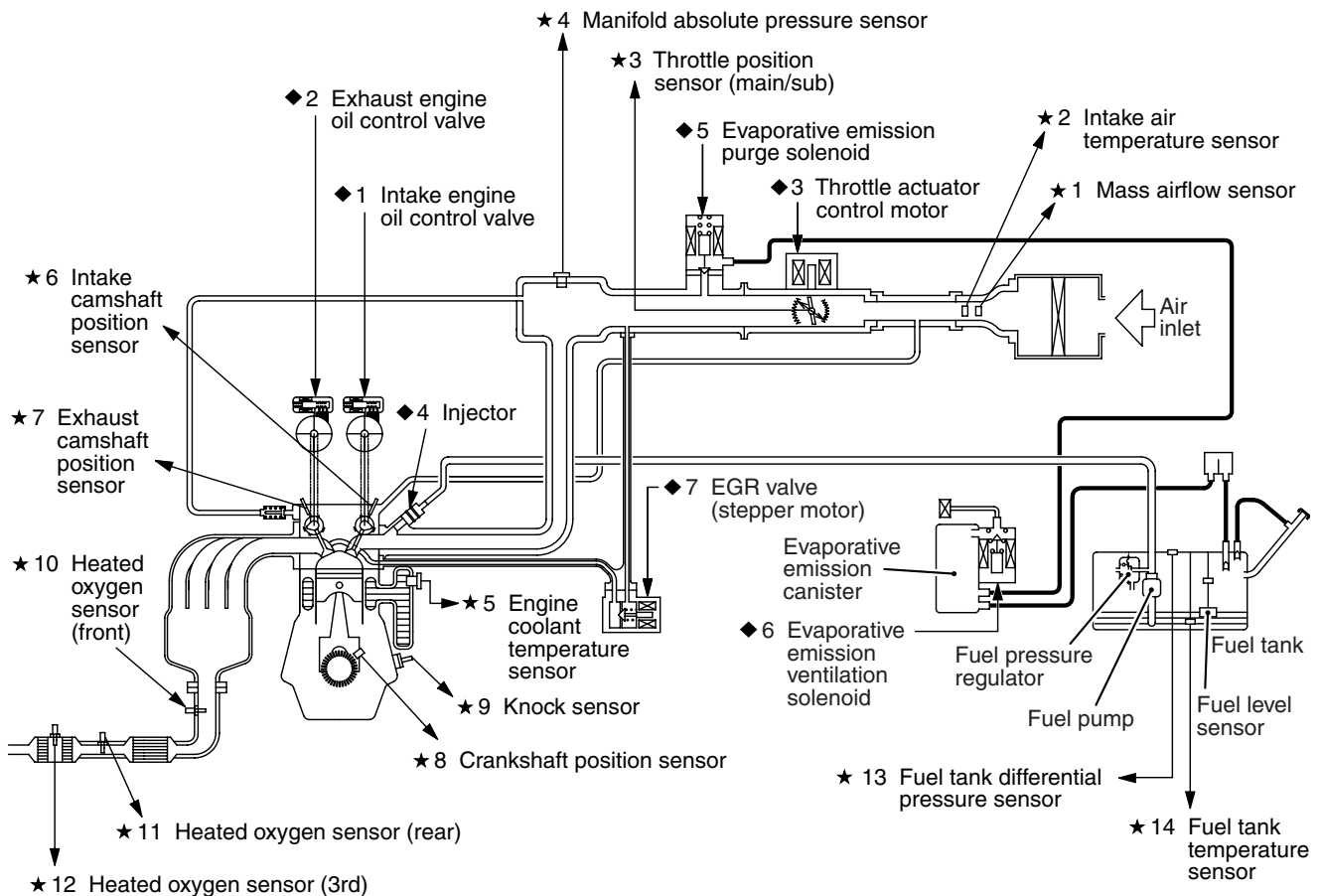

## CONTROL UNIT

M2132021500799

### ENGINE CONTROL MODULE (ECM)

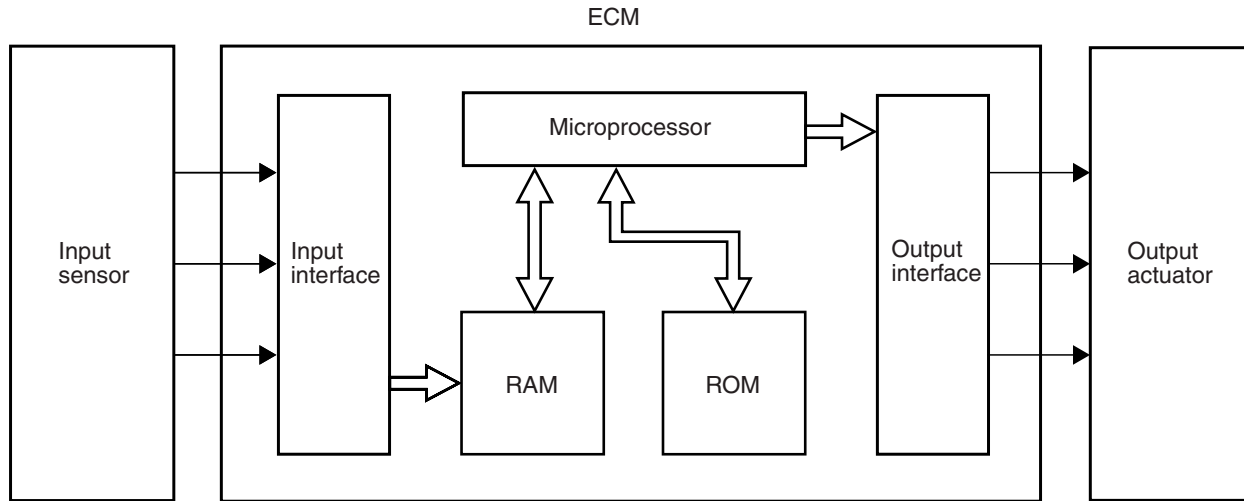

AK604119AB

ECM is installed in the engine room. ECM judges (calculates) the optimum control to deal with the constant minute changes in driving conditions based on information input from the sensors and drives the actuator. ECM is composed of 32-bit microprocessor and Random Access Memory (RAM), Read Only Memory (ROM) and Input /Output interface. ECM

uses flash-memory ROM that allows re-writing of data so that change and correction of control data is possible using special tools. It also uses Electrically Erasable Programmable Read Only Memory (EEPROM) so that studied compensation data is not deleted even if battery terminals are disconnected.

## ECM CONNECTOR INPUT/OUTPUT PIN ARRANGEMENT

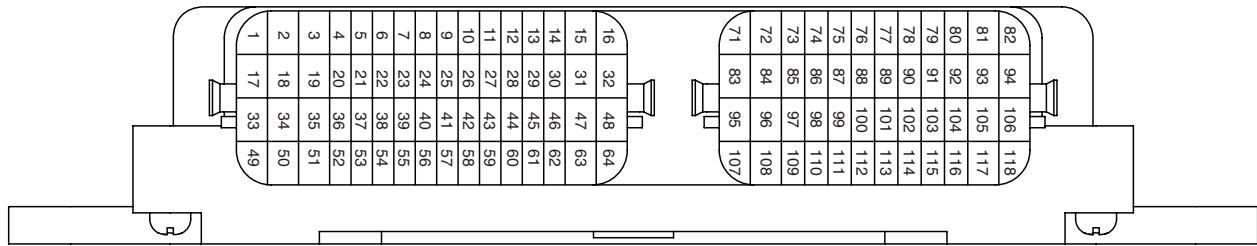

AK602565 AC

1	Intake engine oil control valve	2	No. 1 injector
3	No. 2 injector	4	Ignition coil No. 1 (ignition power transistor)
5	Ignition coil No. 2 (ignition power transistor)	6	Starter active signal
7	Exhaust camshaft position sensor	8	Crankshaft position sensor
9	Sensor supplied voltage	10	Throttle position sensor (main)
11	Throttle position sensor (sub)	12	Power supply voltage applied to throttle position sensor
13	Throttle position sensor ground	14	Intake camshaft position sensor
15	Throttle actuator control motor (+)	16	Throttle actuator control motor (-)
17	Exhaust engine oil control valve	18	No. 3 injector
19	No. 4 injector	20	Ignition coil No. 3 (ignition power transistor)
21	Ignition coil No. 4 (ignition power transistor)	23	Exhaust camshaft position sensor ground
24	Crankshaft position sensor ground	25	Knock sensor (+)
26	Engine coolant temperature sensor	27	Engine coolant temperature sensor ground
30	Intake camshaft position sensor ground	31	EGR valve [stepper motor coil (A)]
32	EGR valve [stepper motor coil (B)]	33	Heated oxygen sensor (3rd) heater <Vehicles for California>
34	Heated oxygen sensor (front) heater	35	Heated oxygen sensor (rear) heater
36	Engine oil pressure switch	37	Evaporative emission purge solenoid
38	Heated oxygen sensor (front)	39	Heated oxygen sensor (front) offset voltage
40	Heated oxygen sensor (rear)	41	Heated oxygen sensor (rear) offset voltage
42	Knock sensor (-)	44	Power supply voltage applied to manifold absolute pressure sensor
45	Manifold absolute pressure sensor	46	Manifold absolute pressure sensor ground
47	EGR valve [stepper motor coil (C)]	48	EGR valve [stepper motor coil (D)]

54	Heated oxygen sensor (3rd) <Vehicles for California>	55	Heated oxygen sensor (3rd) offset voltage <Vehicles for California>
58	Power steering pressure switch	60	Generator G terminal
61	Generator FR terminal	62	Generator L terminal
71	Throttle actuator control motor ground	72	Power supply voltage applied to throttle actuator control motor
73	MFI relay (power supply)	74	Accelerator pedal position sensor (main)
75	Power supply voltage applied to accelerator pedal position sensor (main)	76	Accelerator pedal position sensor (main) ground
77	Accelerator pedal position sensor (sub)	78	Power supply voltage applied to accelerator pedal position sensor (sub)
79	Accelerator pedal position sensor (sub) ground	81	ECM ground
82	Power supply	83	Throttle actuator control motor ground
84	Throttle actuator control motor relay	87	Mass airflow sensor
88	Mass airflow sensor ground	89	Intake air temperature sensor
90	CAN interface (high)	91	CAN interface (low)
92	Ignition switch-IG	93	ECM ground
96	Fuel pump relay	102	A/C compressor clutch relay
103	Flash EP-ROM power supply	104	Backup power supply
105	Ignition switch-ST	106	Starter relay
109	Vehicle speed sensor <M/T>	110	Vehicle speed sensor ground <M/T>
112	Fuel tank differential pressure sensor	113	Fuel tank differential pressure sensor ground
114	Power supply voltage applied to fuel tank differential pressure sensor	115	Fuel tank temperature sensor
117	Evaporative emission ventilation solenoid		

## SENSOR

M2132001001267

### MASS AIRFLOW SENSOR

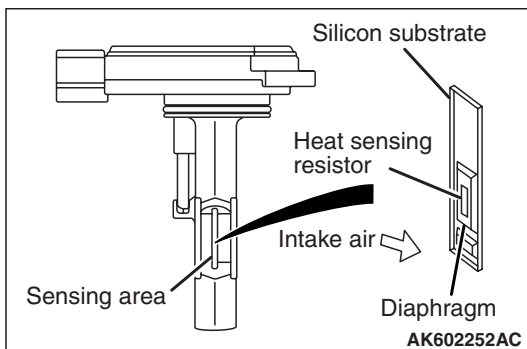

Mass airflow sensor is installed in the air intake hose. Mass airflow sensor is composed of an extremely small heatsensing resistor. The mass airflow sensor controls the amount of electric current flowing into the heat sensing resistor to keep the heat sensing resistor at a constant temperature to the intake air temperature. When the air mass flow rate increases, the air flow speed is higher and also the amount of heat transfer from the heat sensing resistor to the air increased. Therefore, the mass airflow sensor increases the amount of electric current to the heat sensing resistor. Thus, the amount of electric current increases in accordance with the air mass flow rate. The mass

airflow sensor measures the air mass flow rate by detecting the amount of electric current. The mass airflow sensor amplifies the detected electric current amount and outputs it into the ECM. ECM uses this output current and engine speed to calculate and decide basic fuel injection time. Sensor properties are as shown in the figure.

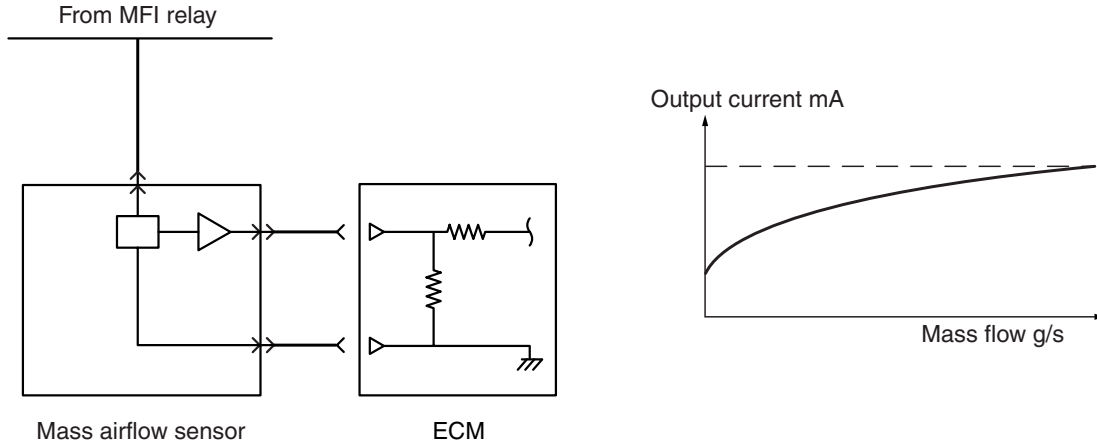

AK602221AG

**INTAKE AIR TEMPERATURE SENSOR**

Intake air temperature sensor is built in to the mass airflow sensor. Intake air temperature sensor detects intake air temperature through thermistor's resistance change and outputs the voltage according to intake air temperature to ECM. ECM uses this output voltage to compensate fuel injection control and ignition timing control. Sensor properties are as shown in the figure.

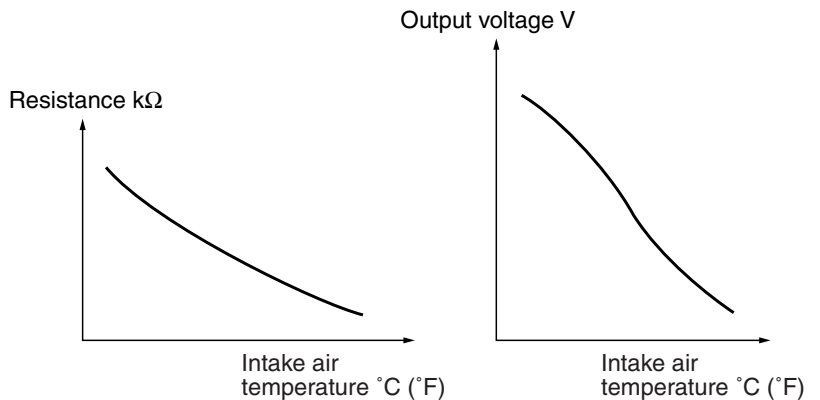
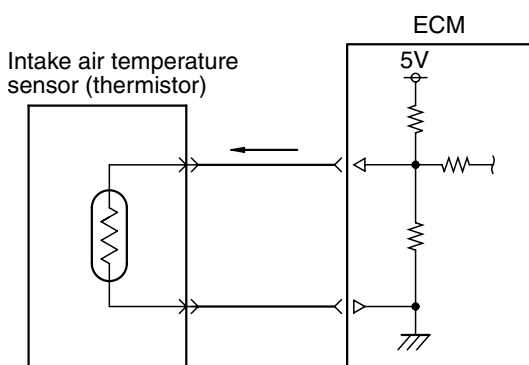
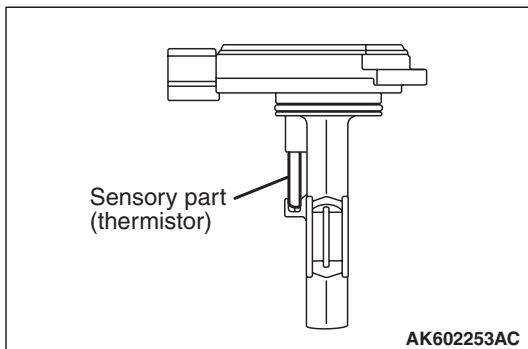

AK602207AG



### MANIFOLD ABSOLUTE PRESSURE SENSOR

The manifold absolute pressure sensor is installed in the intake manifold. Manifold absolute pressure sensor uses a piezo resistive semiconductor to output the voltage according to manifold absolute pressure to ECM. ECM uses this output voltage to compensate fuel injection volume according to manifold absolute pressure. Sensor properties are as shown in the figure.

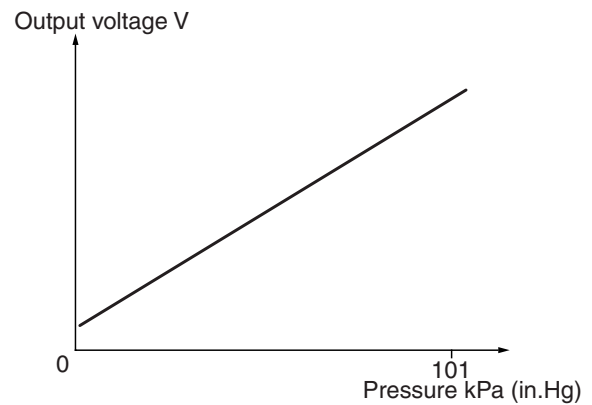
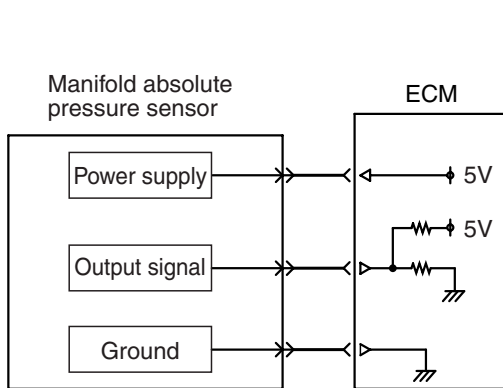
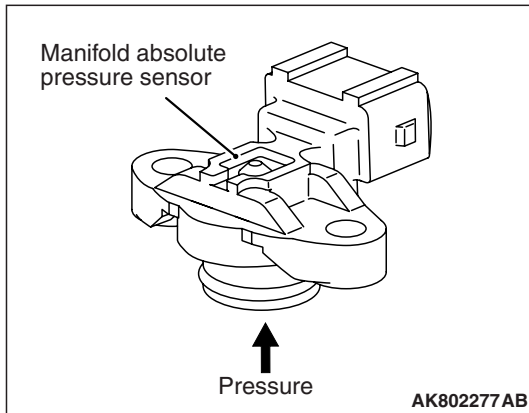

AK602206AH

### ENGINE COOLANT TEMPERATURE SENSOR

The engine coolant temperature sensor is installed in the thermostat housing. Engine coolant temperature sensor uses thermistor's resistance change to detect coolant temperature and output the voltage according to coolant temperature to ECM. ECM uses this output voltage to appropriately control fuel injection volume, idle speed and ignition timing. Sensor properties are as shown in the figure.

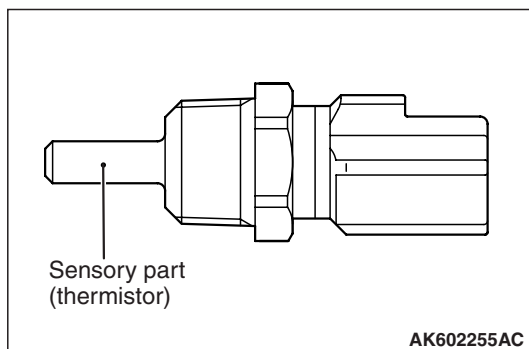

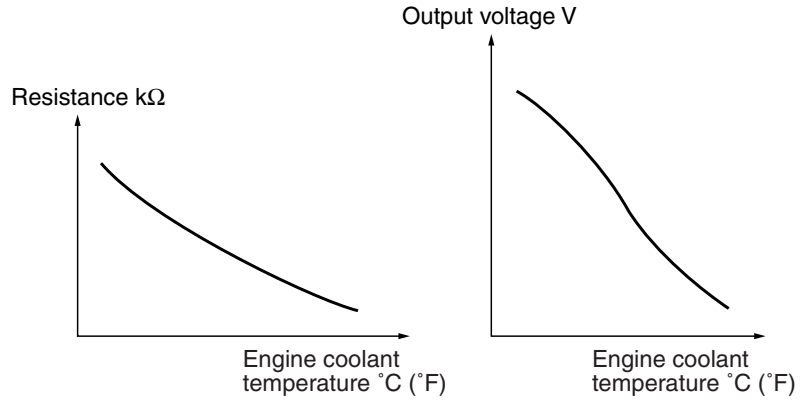
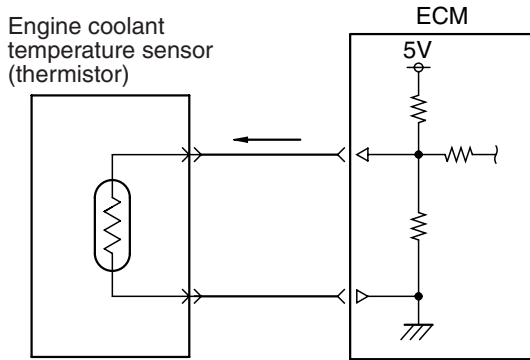

AK602208AG

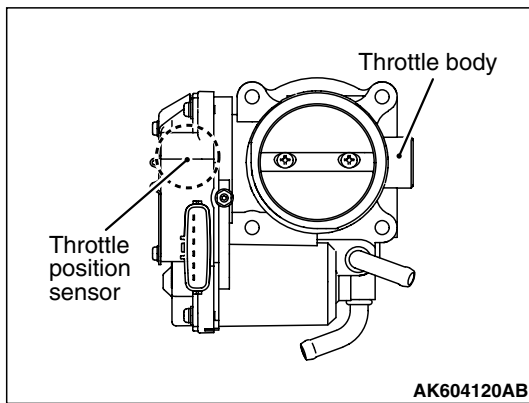

### THROTTLE POSITION SENSOR

The throttle position sensor is installed in the throttle body. Throttle position sensor outputs voltage to ECM based on the throttle shaft rotation angle. ECM uses this signal to detect the throttle valve opening angle to perform throttle actuator control motor feedback control. This throttle position sensor uses Hall IC and is a non-contact type.

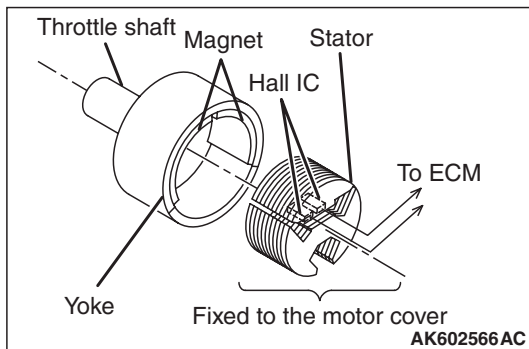

### STRUCTURE AND SYSTEM

Throttle position sensor is composed of a permanent magnet fixed on the throttle shaft, Hall IC that outputs voltage according to magnetic flux density and a stator that efficiently introduces magnetic flux from the permanent magnet to Hall IC.

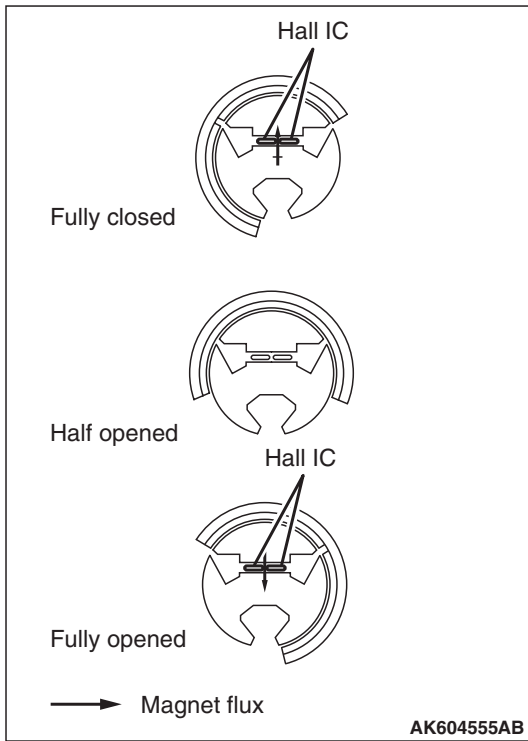

Magnetic flux density at Hall IC is proportional to the output voltage.

Throttle position sensor has 2 output systems –throttle position sensor (main) and throttle position sensor (sub), and the output voltage is output to ECM. When throttle valve turns, output voltage of throttle position sensor (main) and throttle position sensor (sub) changes. This allows ECM to detect actual throttle opening angle. ECM uses this output voltage for throttle actuator control motor feedback control. Also, ECM compares output voltage of the throttle position sensor (main) and throttle position sensor (sub) to check for abnormality in the throttle position sensor. The relationship between throttle opening angle and output voltage of the throttle position sensor (main) and throttle position sensor (sub) is as shown in the figure below.

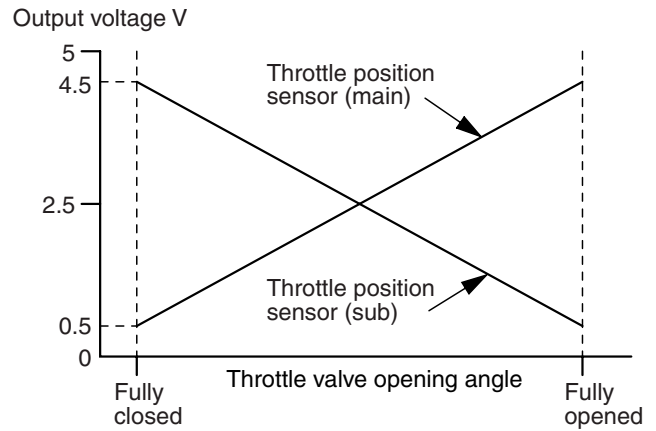
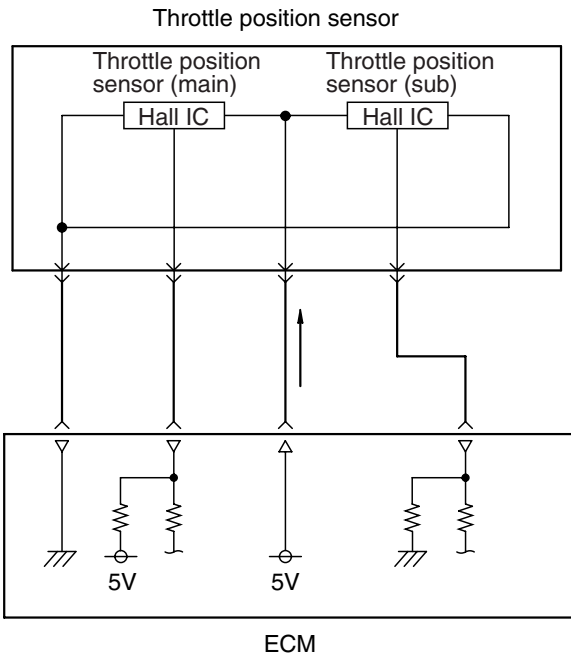

**ACCELERATOR PEDAL POSITION SENSOR**

Accelerator pedal position sensor is integrated with accelerator pedal, and detects accelerator opening angle. ECM uses the output voltage of this sensor to control appropriate throttle valve opening angle and fuel injection volume. This accelerator pedal position sensor uses Hall IC and is a non-contact type.

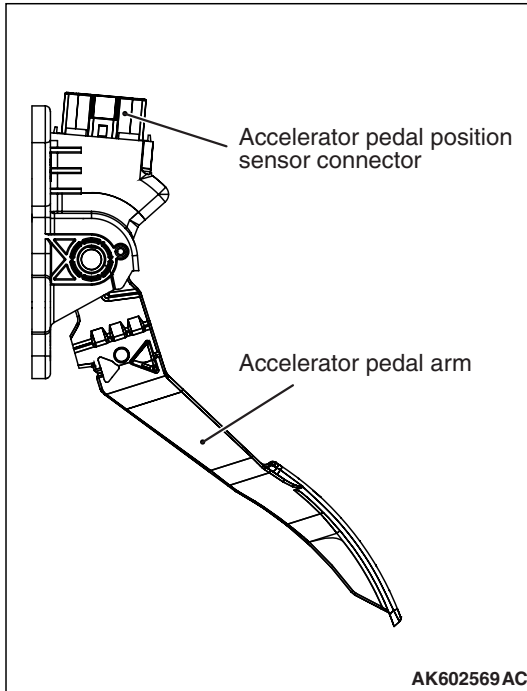
**STRUCTURE AND SYSTEM**

Accelerator pedal position sensor is composed of a permanent magnet fixed on the magnet carrier of the pedal shaft, Hall IC outputs voltage according to magnetic flux density and a stator that efficiently introduces magnetic flux from the permanent magnet to Hall IC.

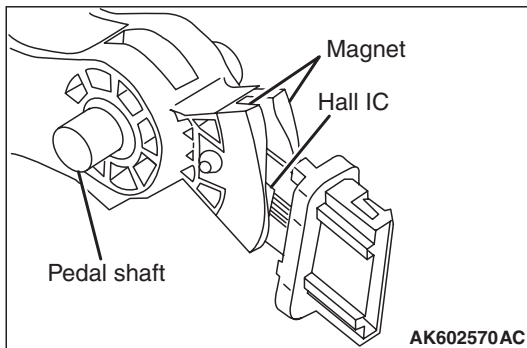

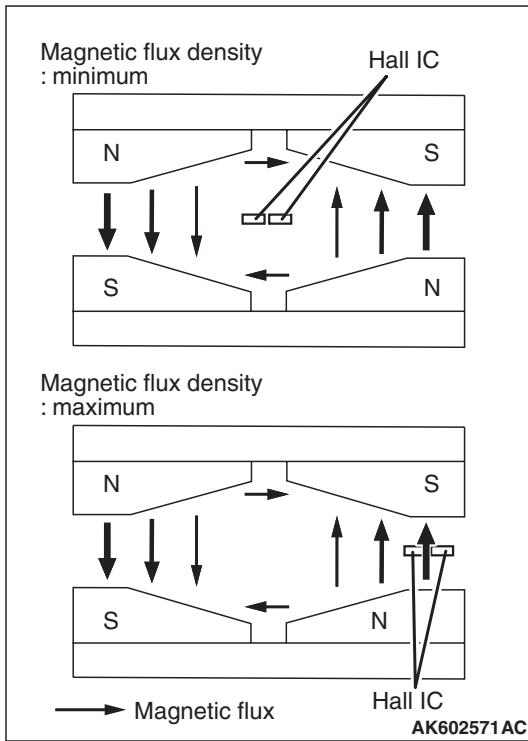

Magnetic flux density at Hall IC is proportional to the output voltage.

The accelerator pedal position sensor has 2 output systems – accelerator pedal position sensor (main) and accelerator pedal position sensor (sub), and the output voltage is output to ECM. According to depression of the accelerator pedal, output voltage of the accelerator pedal position sensor (main) and accelerator pedal position sensor (sub) changes. This allows ECM to detect the actual accelerator pedal depression amount. ECM uses accelerator pedal position sensor (main) output voltage for appropriate throttle valve opening angle control and fuel injection volume control. Also, ECM compares output voltage of the accelerator pedal position sensor (main) and accelerator pedal position sensor (sub) to check for abnormality in sensor. The relationship between accelerator opening angle and output voltage of the accelerator pedal position sensor (main) and accelerator pedal position sensor (sub) is as shown in the figure below.

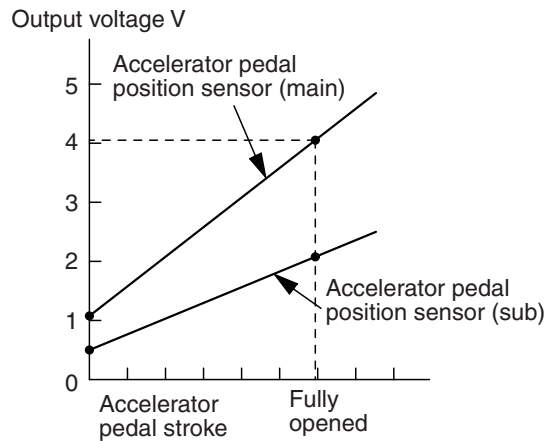
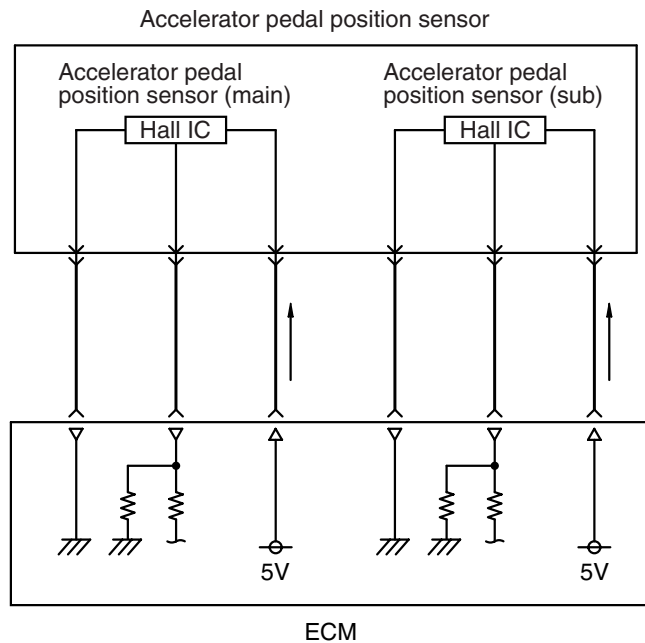

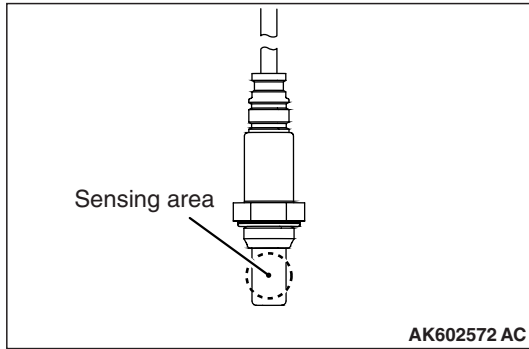

AK602572 AC

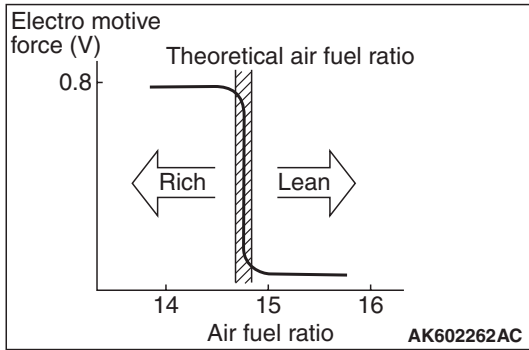

AK602262 AC

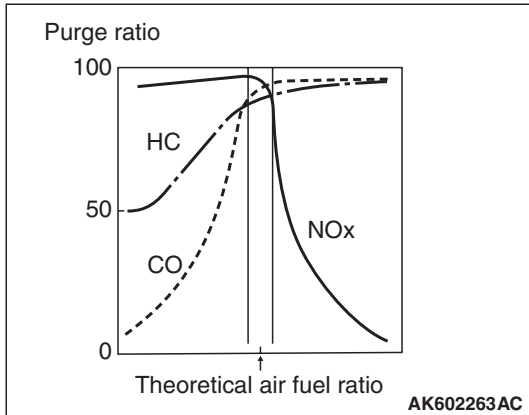

AK602263 AC

**HEATED OXYGEN SENSOR [except heated oxygen sensor (3rd) <Vehicles for California>]**

Heated oxygen sensors are installed in 2 positions (front, rear) near the catalytic converter. Heated oxygen sensor has a built-in heater to help early activation of the sensor. This allows feedback control of air-fuel ratio soon after engine start.

This sensor uses the oxygen concentration cell principle of solid electrolyte (zirconia) and displays the property of sudden change in output voltage near theoretical air-fuel ratio. This property is used to detect oxygen density in exhaust gas. Feedback to ECM allows it to judge whether air-fuel ratio is rich or lean compared to theoretical air-fuel ratio.

This allows ECM precise feedback control to get theoretical air-fuel ratio with best cleaning efficiency of 3-way catalytic converter.

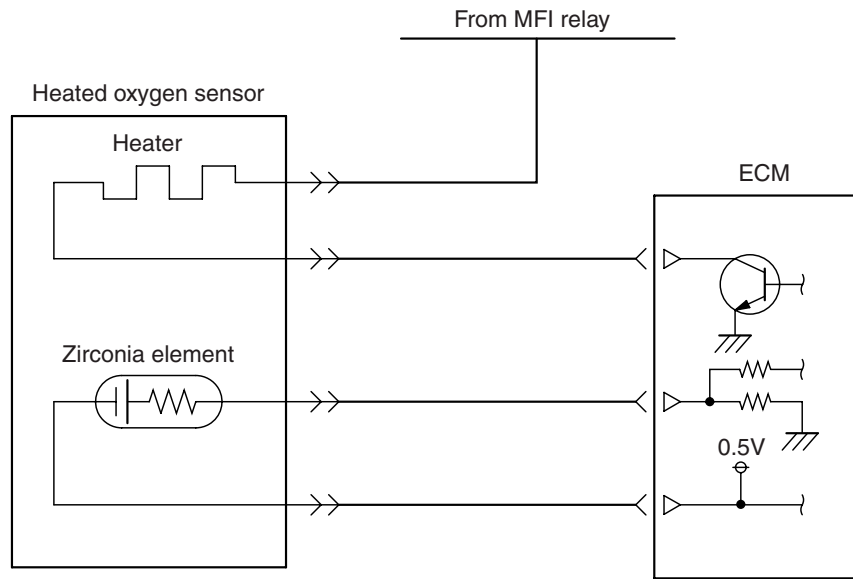

AK602576AE

**CRANKSHAFT POSITION SENSOR**

A crankshaft position sensor is installed on the exhaust side of the cylinder block. The crankshaft position sensor monitors rotation of crankshaft sensing ring (36 teeth including 3 missing teeth) installed on the crankshaft and converts to voltage (pulse signal) that is output to ECM. ECM uses crankshaft position sensor's output pulse to detect crankshaft position.

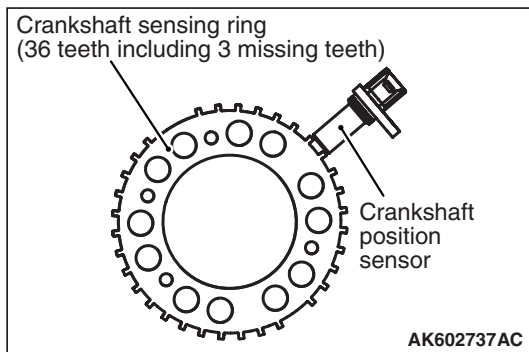

AK602737AC

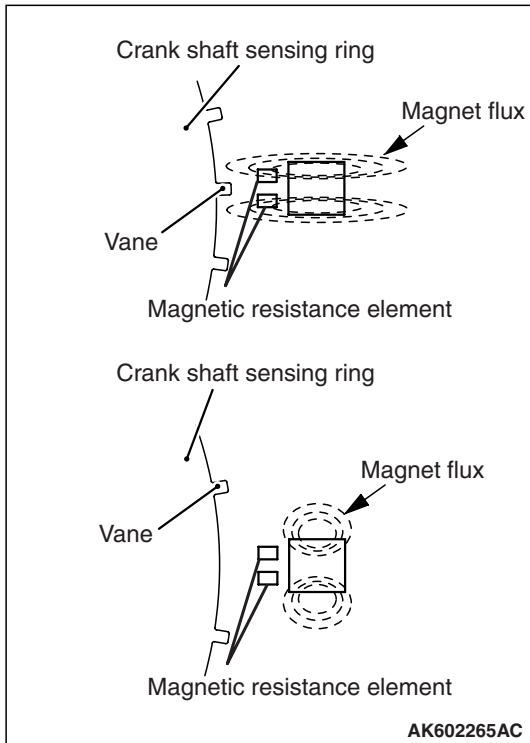

The crankshaft position sensor uses a magnetic resistance element. When the vane of the crankshaft-sensing ring passes the front surface of the magnetic resistance element, the flux from the magnet passes the magnetic resistance element. Thus, resistance of the magnetic resistance element increases. When the vane of the crankshaft-sensing ring does not pass the front surface of the magnetic resistance element, the flux from the magnet does not pass the magnetic resistance element and the resistance decreases. The crankshaft position sensor converts this change in resistance of the magnetic resistance element to a 5 V pulse signal and outputs it to ECM.

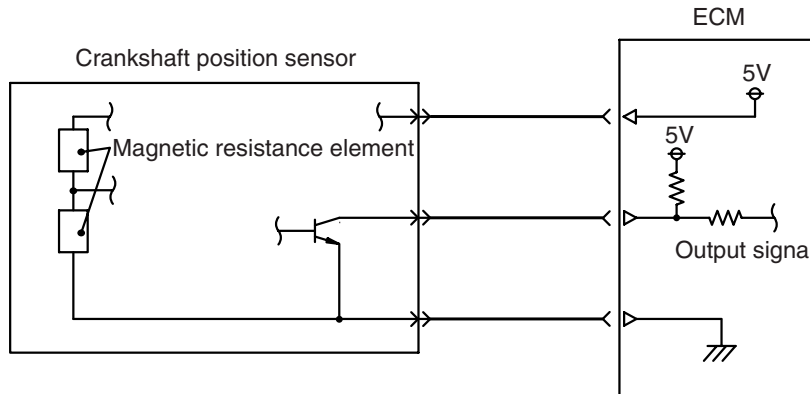

AK602285 AC

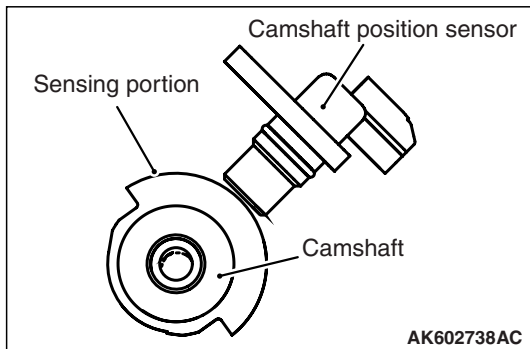

**INTAKE CAMSHAFT POSITION SENSOR**

The intake camshaft position sensor is installed on the intake side of the cylinder head. The intake camshaft position sensor monitors shape of the half-moon sensing portion and converts to voltage (pulse signal) that is output to ECM. Upon receiving this output voltage, the ECM effects feedback control to optimize the phase of the intake camshaft. Also, ECM uses a combination of the intake camshaft position sensor output pulse signal and crankshaft position sensor output pulse signal to identify cylinders in the compression process.



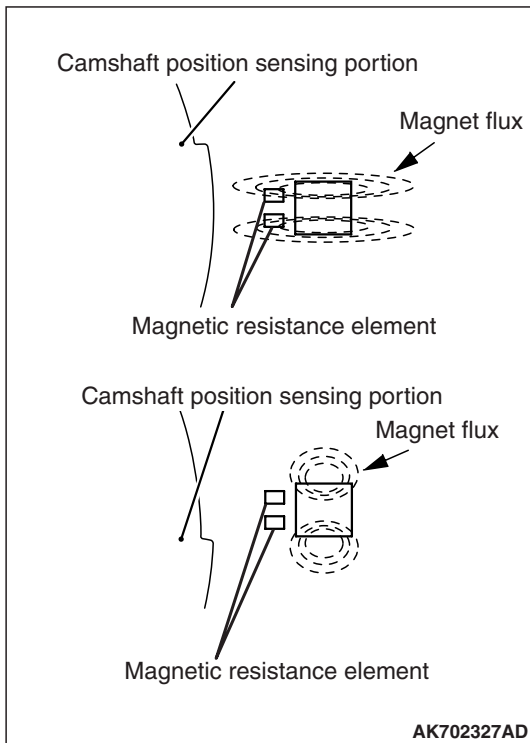

The intake camshaft position sensor uses a magnetic resistance element. When the camshaft position sensing portion passes the front surface of the magnetic resistance element, the flux from the magnet passes the magnetic resistance element. Thus, resistance of the magnetic resistance element increases. When the camshaft position sensing portion does not pass the front surface of the magnetic resistance element, the flux from the magnet does not pass the magnetic resistance element and the resistance decreases. The intake camshaft position sensor converts this change in resistance of the magnetic resistance element to a 5 V pulse signal and outputs it to ECM

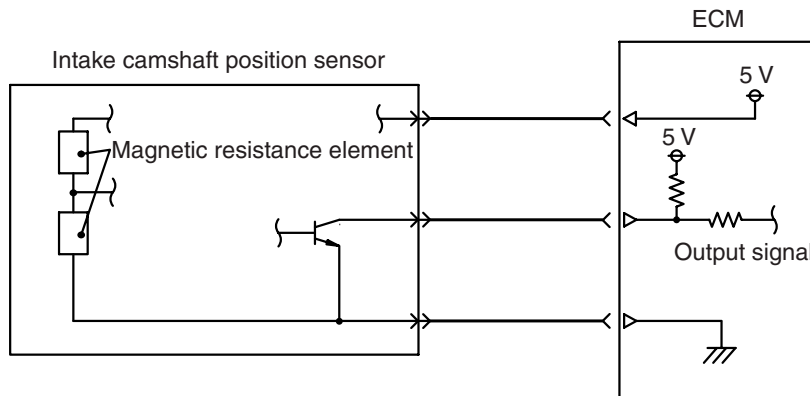

AK602287AG

### EXHAUST CAMSHAFT POSITION SENSOR

The exhaust camshaft position sensor is installed on the exhaust side of the cylinder head. The exhaust camshaft position sensor monitors shape of the half-moon sensing portion and converts to voltage (pulse signal) that is output to ECM. Upon receiving this output voltage, the ECM effects feedback control to optimize the phase of the exhaust camshaft. The structure and system of this sensor are basically the same as intake camshaft position sensor.

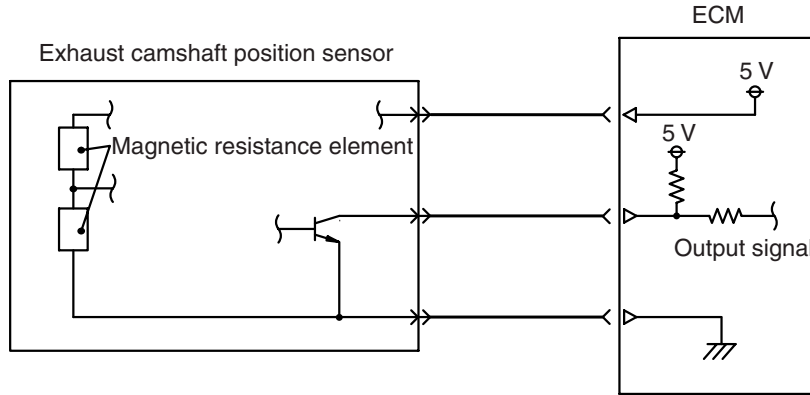

AK602287AH

**KNOCK SENSOR**

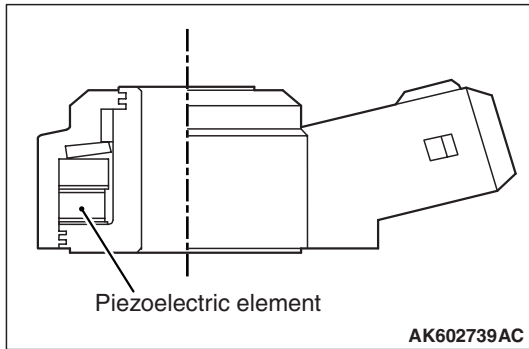

AK602739AC

A knock sensor is installed on the intake side of the cylinder block. Knock sensor uses the piezoelectric element to convert the vibration of the cylinder block generated when engine is in operation to minute voltage that is output to ECM. ECM uses the minute output voltage from the knock sensor filtered through the cylinder block's natural frequency to detect knocking, and compensates the ignition timing lag according to the strength of the knocking.

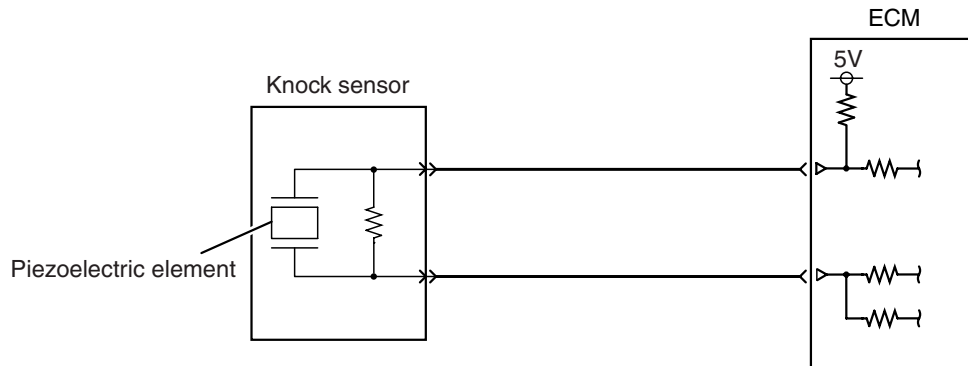

AK602226AD

### BAROMETRIC PRESSURE SENSOR

A barometric pressure sensor is built into ECM. The barometric pressure sensor is a semiconductor diffused pressure element which outputs voltage to ECM according to atmospheric pressure. ECM uses this output voltage to sense the altitude of the vehicle and compensates fuel injection volume to achieve the appropriate air-fuel ratio for that altitude.

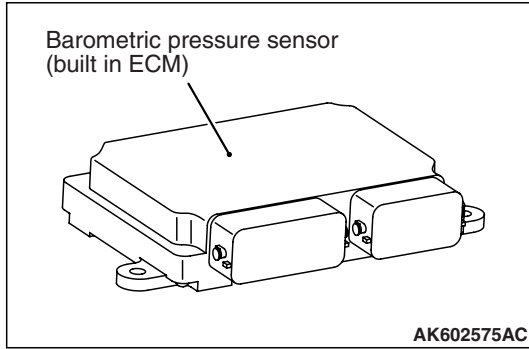

### ENGINE OIL PRESSURE SWITCH

The engine oil pressure switch is installed on the intake side of the cylinder block. The engine oil pressure switch detects whether the oil pressure is high or low using the contact switch. When the oil pressure becomes higher than the specified value after the engine starts, the contact point of the engine oil pressure switch opens. This allows the ECM to detect the oil pressure is higher than the specified value. The ECM outputs the OFF signal to the combination meter through the CAN and then turns off the oil pressure warning lamp.

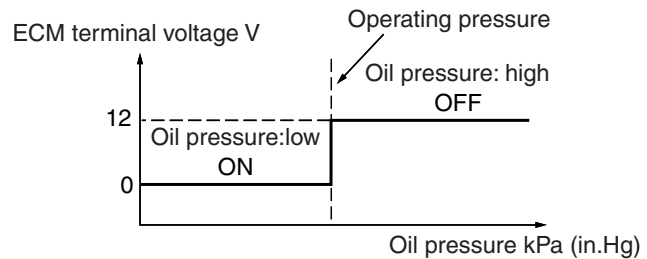
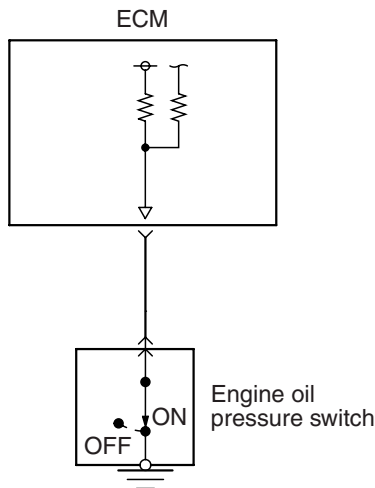
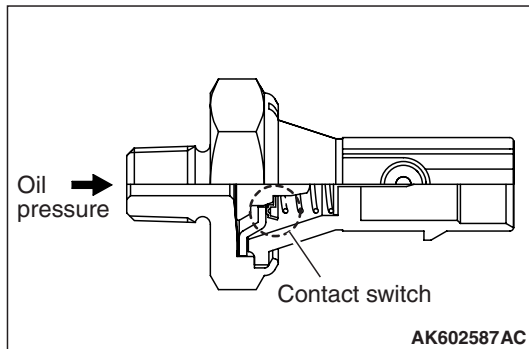

**POWER STEERING PRESSURE SWITCH**

A power steering pressure switch is installed on the power steering oil pump. The power steering pressure switch uses a contact switch to detect the power steering oil pressure. When power steering oil pressure rises due to operation of the steering wheel, the power steering pressure switch outputs an ON signal to ECM. ECM performs idle-up according to the voltage and prevents reduction in engine speed due to power steering load and so maintains stable idle speed.

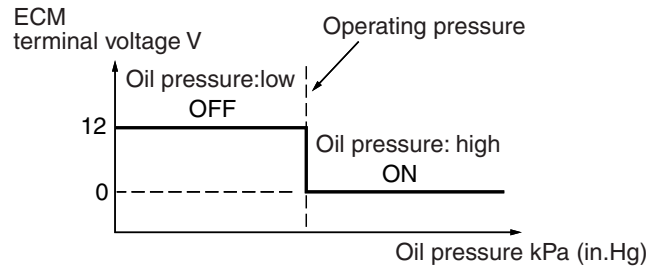
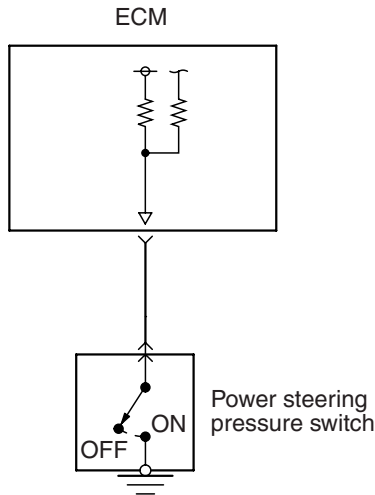
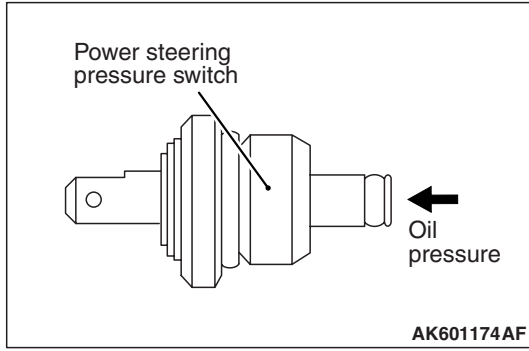

AK602213AE

**FUEL TANK DIFFERENTIAL PRESSURE SENSOR**

The fuel tank differential pressure sensor is installed to the fuel pump module. The fuel tank differential pressure sensor outputs the voltage to the ECM using the piezo resistive semiconductor in accordance with the difference between pressure in the fuel tank and the pressure of the atmosphere. When monitoring the evaporative leak, the ECM detects malfunctions of the evaporative emission control system by monitoring the amount of output voltage changes from this sensor. The sensor characteristics are as shown in the diagram.

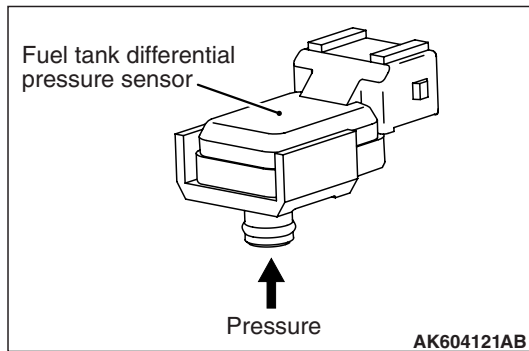

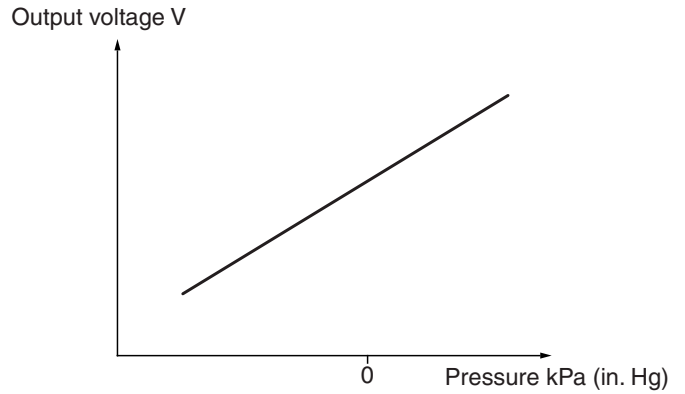
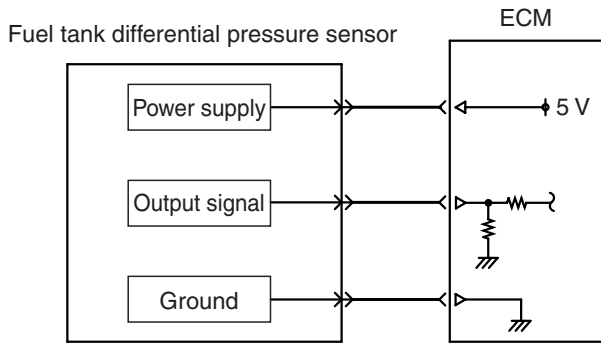

AK604122 AB

### FUEL TANK TEMPERATURE SENSOR

The fuel tank temperature sensor is installed to the fuel pump module. The fuel tank temperature sensor detects the temperature inside the fuel tank using the resistance change in the thermistor and outputs the voltage to the ECM in accordance with the temperature inside the fuel tank. The ECM monitors the evaporative leak in accordance with the fuel tank temperature. The sensor characteristics are as shown in the diagram.

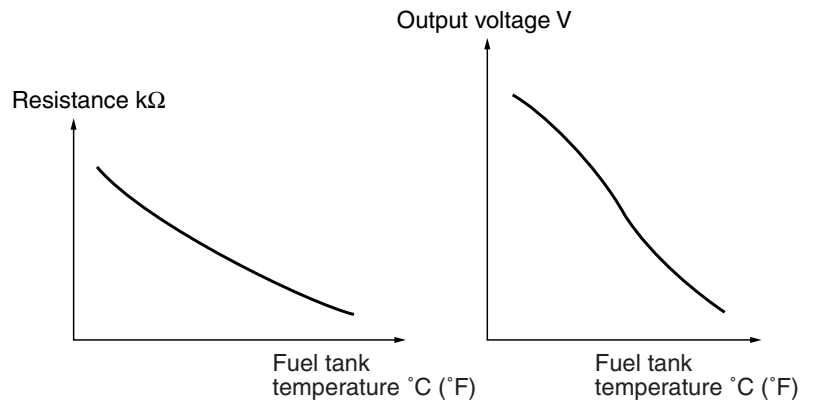
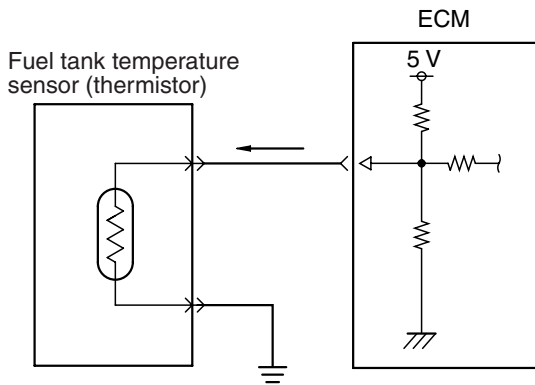
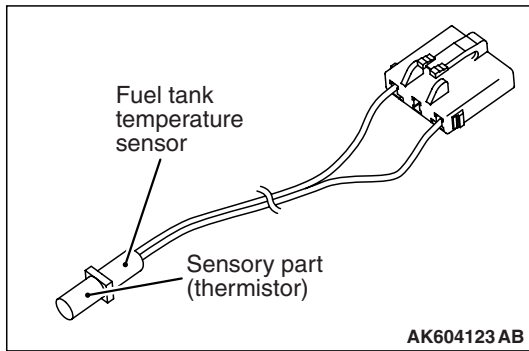

AK604124 AB

**GENERATOR FR TERMINAL**

Generator turns ON/OFF the power transistor in the voltage regulator to adjust current flow in the field coil according to generator output current. In this way generator's output voltage is kept adjusted (to about 14.4 V). The ratio of power transistor ON time (ON duty) is output from generator FR terminal to ECM. ECM uses this signal to detect generator's output current and drives throttle actuator control motor according to output current (electric load). This prevents change in idle speed due to electric load and helps maintain stable idle speed.

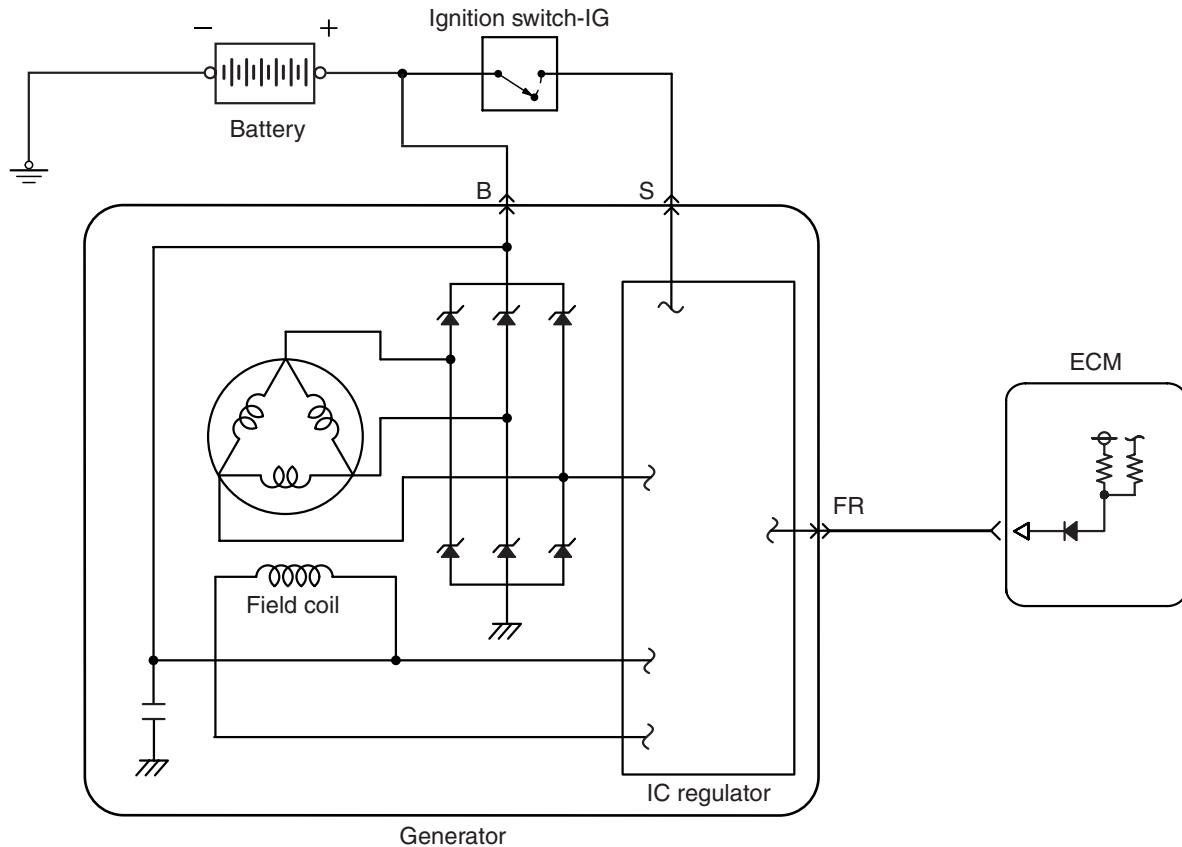

AK602229AD

**GENERATOR L TERMINAL**

After turning on the ignition switch, the current is input by the ECM to the generator L terminal. This allows the IC regulator to be on and the field coil to be excited. When the generator rotates in this situation, the voltage is excited in the stator coil and the current is output from B-terminal through the commutation diode. Also the generated voltage is input to the voltage regulator through the commutation diode. After the electric generation begins, the current is supplied to the field coil from this circuit. In addition, the generated voltage is output from the generator L terminal to the ECM. This allows the ECM to detect that the electric generation begins. The ECM outputs the ON signal to the combination meter through the CAN and then turns off the generator malfunction light.

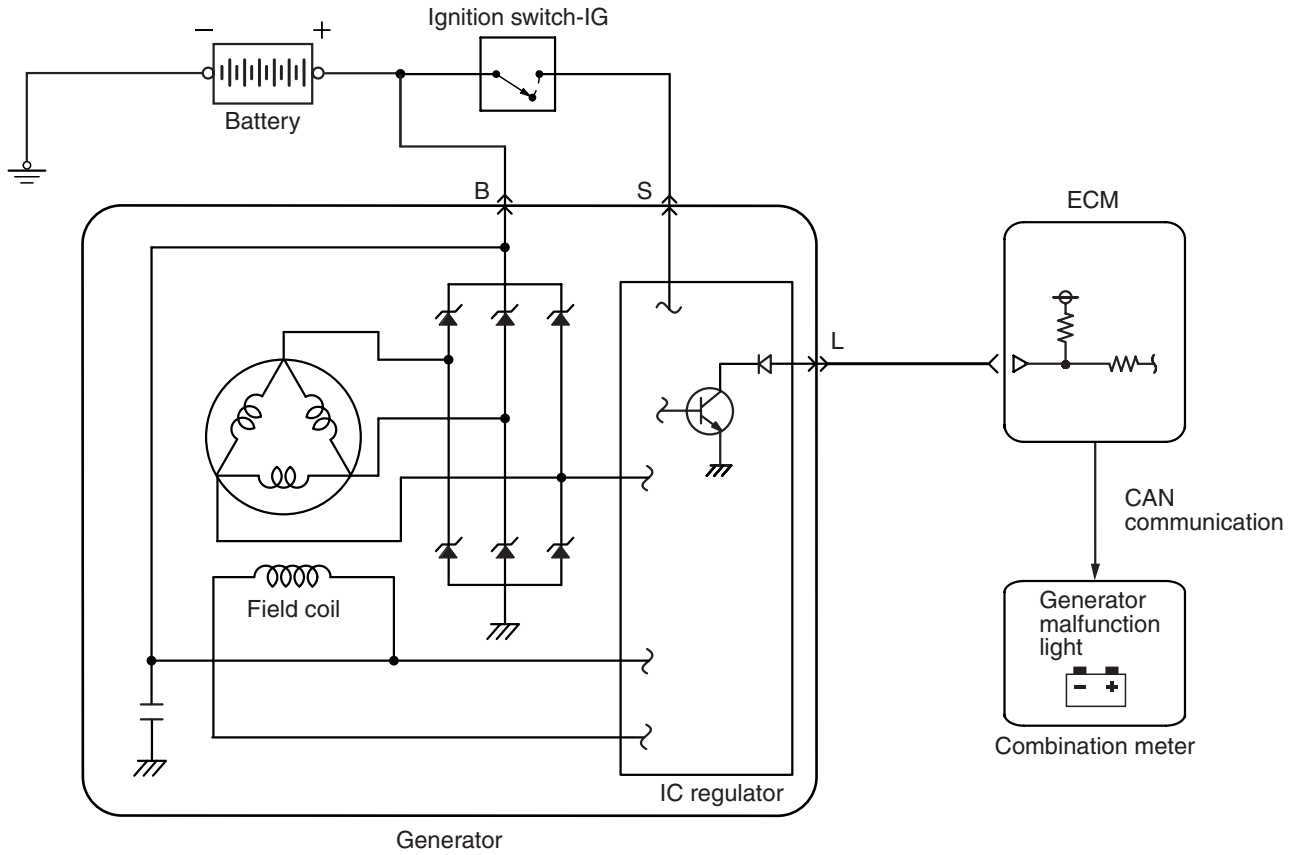

## ACTUATOR

M2132002000922

### INJECTOR

An injector is an injection nozzle with the electromagnetic valve that injects fuel based on the injection signal sent by ECM. 1 injector is installed in the intake manifold of each cylinder and fixed to the fuel rail. When electricity flows through the solenoid coil, the needle gets sucked in. The needle gets pulled till the fully open position so that the injection hole is fully open and the fuel gets injected.

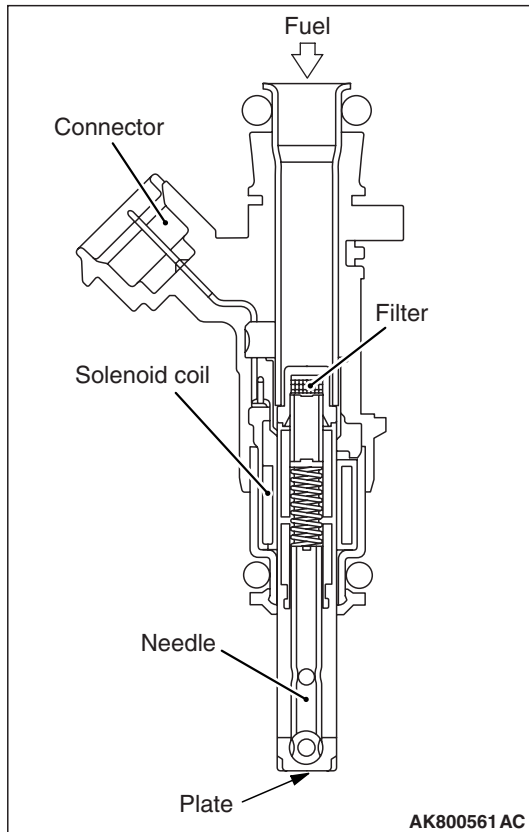



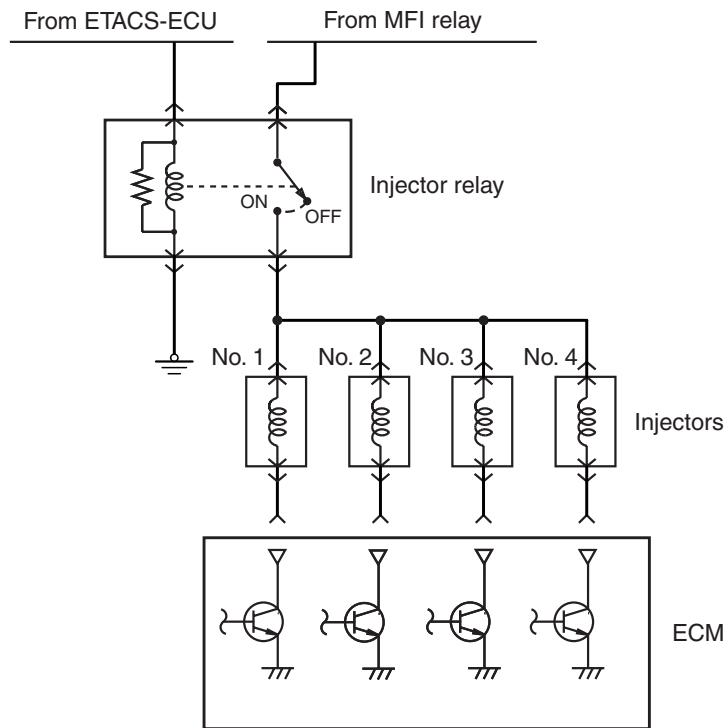

AK704676 AB

Voltage from the battery gets applied from the injector relay to the injector and up to the ECM. ECM turns ON its power transistor and prepares the injector's ground circuit. Thus, current flows through the injector while power transistor is ON and the injector injects fuel.

### THROTTLE ACTUATOR CONTROL MOTOR

A throttle actuator control motor is installed in throttle body. The throttle actuator control motor performs the Open/Close of the throttle valve through the reduction gear. ECM changes current direction according to the Open/Close direction and also changes current to the motor coil to control the throttle actuator control motor.

Throttle actuator control motor is composed of a good response, low energy, and small DC motor with brush and can generate rotation force corresponding to the current applied on the coil. When there is no current passing through the throttle actuator control motor, the throttle valve remains at a prescribed opening angle. So, even if current stops because of a fault in the system, a minimum level of running remains possible.

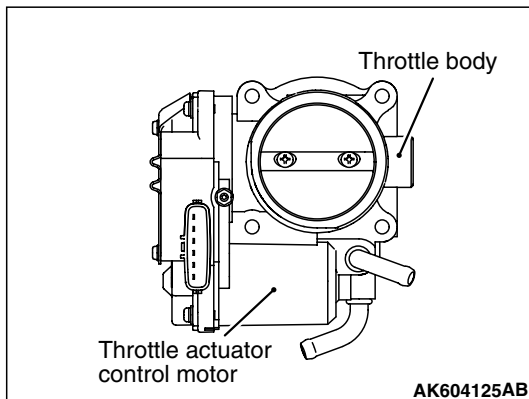

AK604125AB

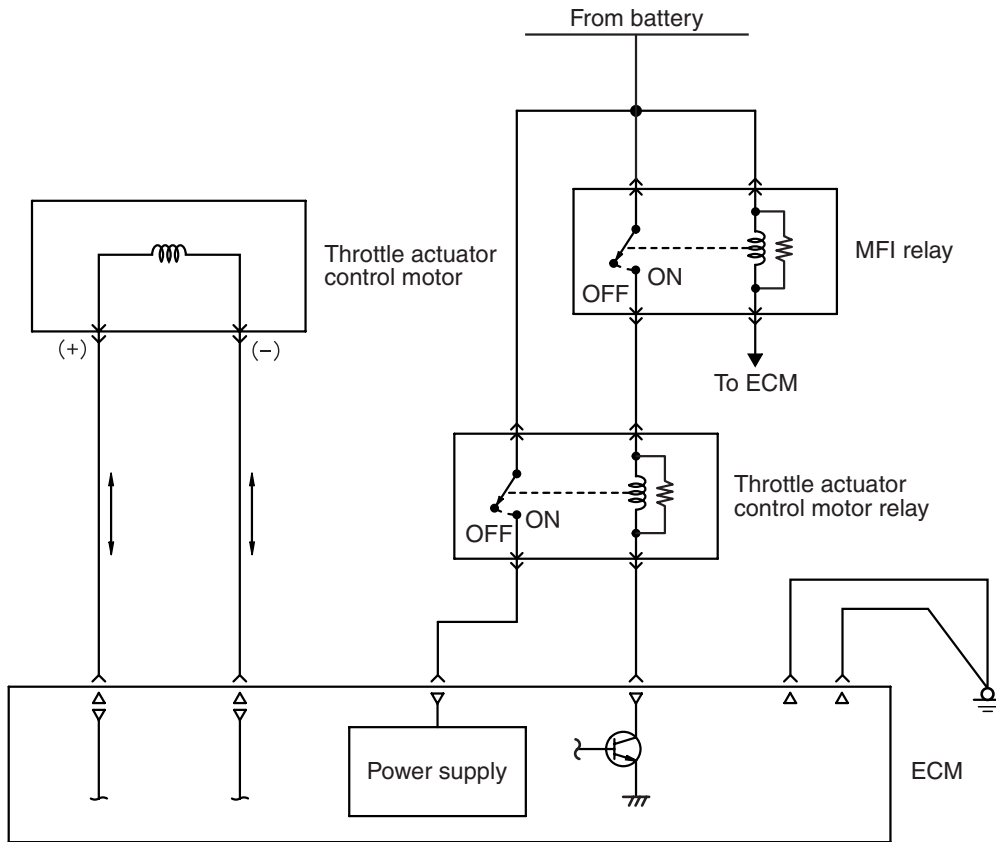

AK602231 AE

### IGNITION COIL

Refer to GROUP 16 –Ignition Coil [P.16-4](#).

### EXHAUST GAS RECIRCULATION (EGR) VALVE

Refer to GROUP 17 –Emission Control –Exhaust Gas Recirculation (EGR) System <2.4L ENGINE> [P.17-18](#).

### EVAPORATIVE EMISSION PURGE SOLENOID

Refer to GROUP 17 –Emission Control –Evaporative Emission Control System [P.17-15](#).

### INTAKE ENGINE OIL CONTROL VALVE

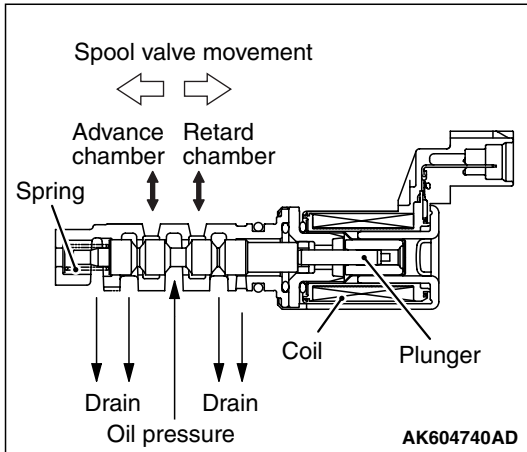

The intake engine oil control valve is installed on the intake side of the cylinder head. Receiving the duty signal from the ECM, the intake engine oil control valve moves the spool valve position and divides the oil pressure from the cylinder block into the advanced chamber and the retarded chamber of the V.V.T. sprocket as well as continually changes the intake camshaft phase. The ECM moves the spool valve position by increasing and decreasing ON duty ratio of the intake engine oil control valve and allows the intake camshaft to be at the target phase angle. When the duty ratio increases, the spool valve moves. The sprocket rotates toward the advanced angle side. When the duty ratio decreases, the sprocket rotates toward the retarded angle side. When the medium duty ratio, at which the spool valve is at the medium position, is achieved, all the oil passages are closed. This allows the phase angle to be kept constant. The ECM changes and controls the duty ratio in accordance with the engine operation to get the optimum phase angle.

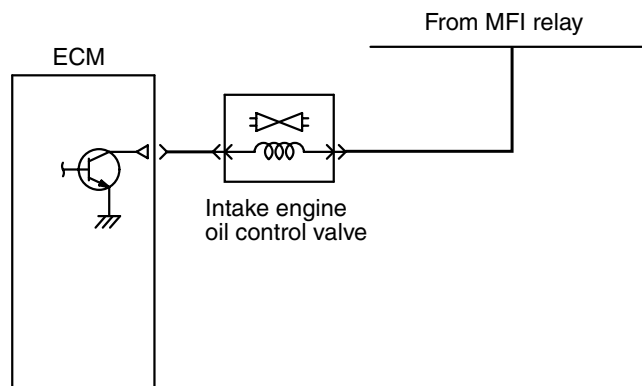

AK700721 AD

### EXHAUST ENGINE OIL CONTROL VALVE

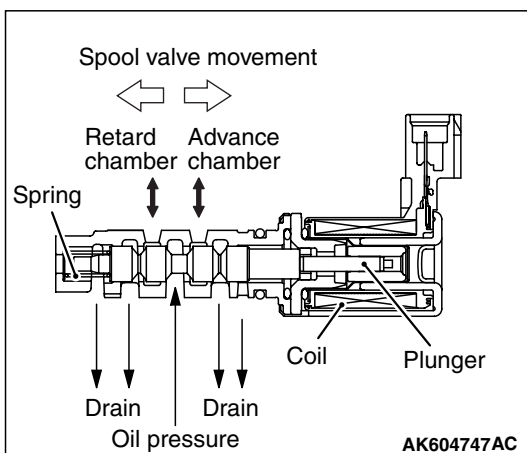

The exhaust engine oil control valve is installed on the exhaust side of the cylinder head. Receiving the duty signal from the ECM, the exhaust engine oil control valve moves the spool valve position and divides the oil pressure from the cylinder block into the advanced chamber and the retarded chamber of the V.V.T. sprocket as well as continually changes the exhaust camshaft phase. The spring makes spool valve stop at the position where the exhaust camshaft is at the most advanced angle when the engine is stopped. The ECM moves the spool valve position by increasing and decreasing ON duty ratio of the exhaust engine oil control valve and allows the exhaust camshaft to be at the target phase angle. When the duty ratio increases, the spool valve moves. The sprocket rotates toward the retarded angle side. When the duty ratio decreases, the sprocket rotates toward the advanced angle side. When the

medium duty ratio, at which the spool valve is at the medium position, is achieved, all the oil passages are closed. This allows the phase angle to be kept constant. The ECM changes and controls the duty ratio in accordance with the engine operation to get the optimum phase angle.

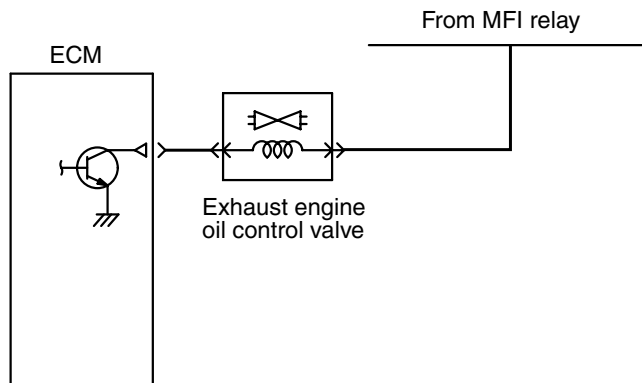

AK700722 AD

## EVAPORATIVE EMISSION VENTILATION SOLENOID

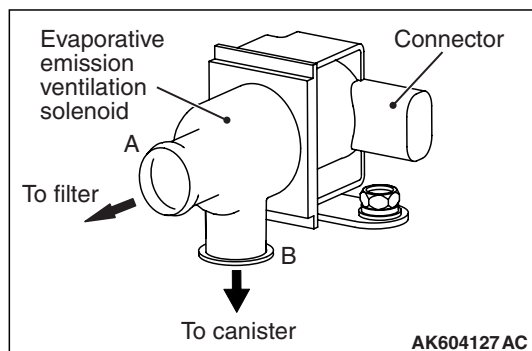

The evaporative emission ventilation solenoid, an ON/OFF type solenoid valve, is integrated in the evaporative canister. The evaporative emission ventilation solenoid is installed between the evaporative canister and the air-releasing end, where the evaporative emission ventilation solenoid takes or shuts off air. When the current is not flowing through the coil, the air flows between the nipples, "A" and "B", and through the evaporative canister. When the current is flowing through the coil, the air is sealed in the nipple "A" and the air through the evaporative canister is shut off. When monitoring the evaporative leak, the ECM turns the evaporative emission ventilation solenoid ON to create the slight vacuum condition in the evaporative emission control system. The ECM shuts off the air flowing through the evaporative canister to maintain the vacuum condition necessary for monitoring.

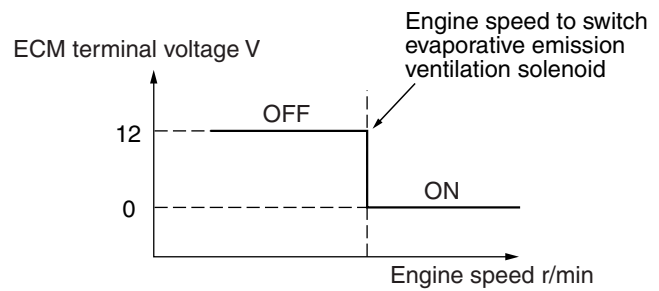
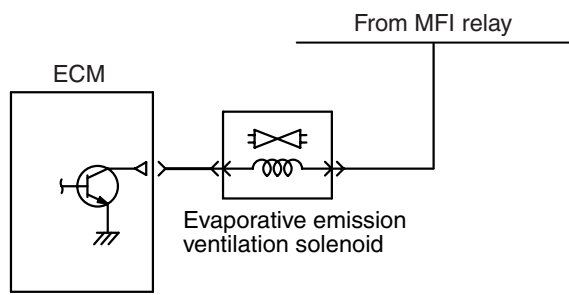

AK604554 AB

### GENERATOR G TERMINAL

ECM uses ON/OFF of generator G terminal to control generator output voltage. When the power transistor in the ECM turns ON, output voltage gets adjusted to about 12.8 V. When generator output voltage drops to 12.8 V it becomes lower than voltage of the charged battery and almost no current is output from the generator. When the power transistor in the ECM turns OFF, output voltage gets adjusted to about 14.4 V. When generator output voltage is about 14.4 V, generator outputs current to produce electricity. In case electric load is generated suddenly, ECM controls generator G terminal's On-duty to limit the sudden increase in generator load due to generation and thus prevents change in idle speed.

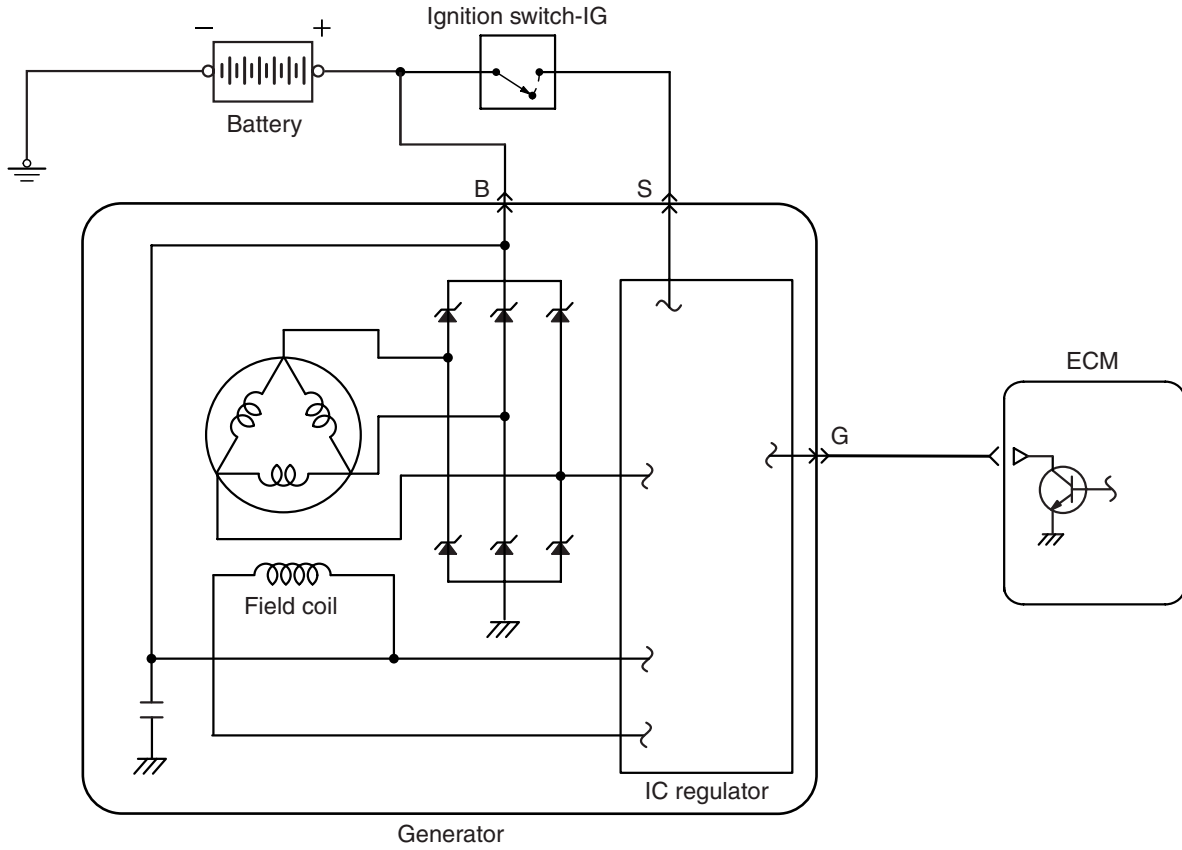

## FUEL INJECTION CONTROL

M2132003001638

Fuel injection volume is regulated to obtain the optimum air-fuel ratio in accordance with the constant minute changes in engine driving conditions. Fuel injection volume is controlled by injector drive time (injection time). There is a prescribed basic drive time that varies according to the engine speed and

intake air volume. ECM adds prescribed compensations to this basic drive time according to conditions such as the intake air temperature and engine coolant temperature to decide injection time. Fuel injection is done separately for each cylinder and is done once in two engine rotations.

### System Configuration Diagram

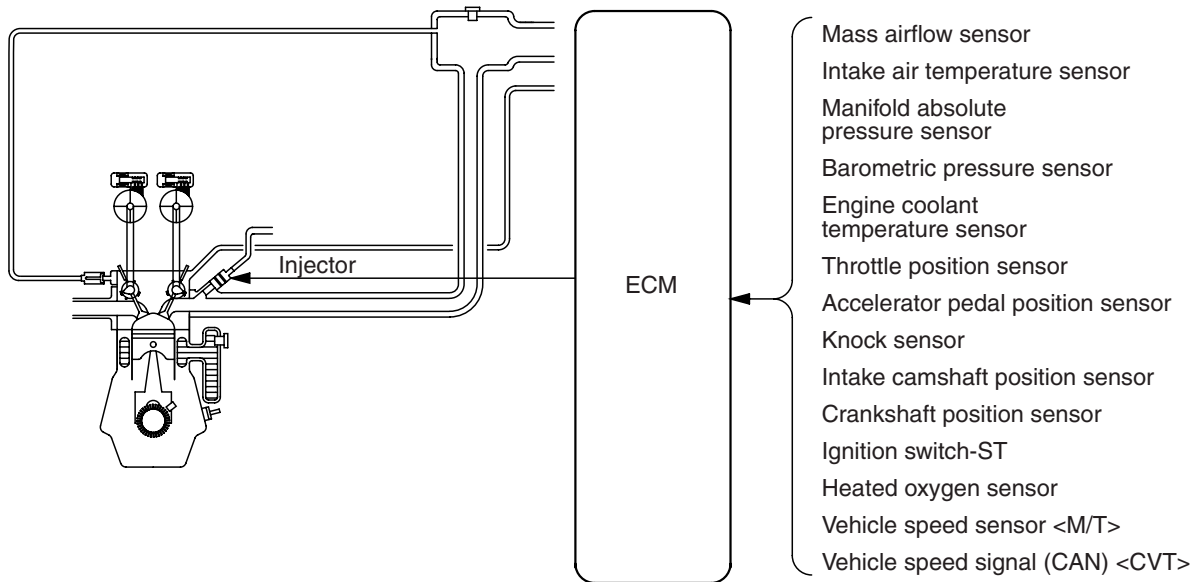

AK604128AC

### 1. INJECTOR ACTUATION (FUEL INJECTION) TIMING

Injector drive time in case of multipoint fuel injection (MFI) is controlled as follows according to driving conditions.

Fuel Injection During Cranking and Normal Operation

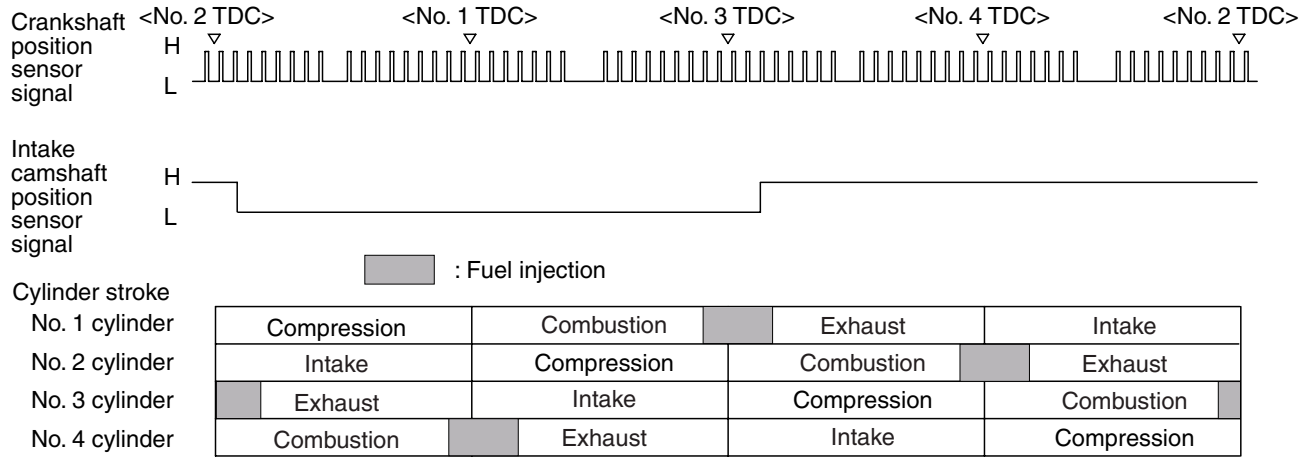

AK703691 AC

Fuel injection to each cylinder is done by driving the injector at optimum timing while it is in exhaust process based on the crankshaft position sensor signal. ECM compares the crankshaft position sensor output pulse signal and intake camshaft position sensor output pulse signal to identify the cylinder. Using this as a base, it performs sequential injection in the sequence of cylinders 1, 3, 4, 2.

Additional Fuel Injection During Acceleration

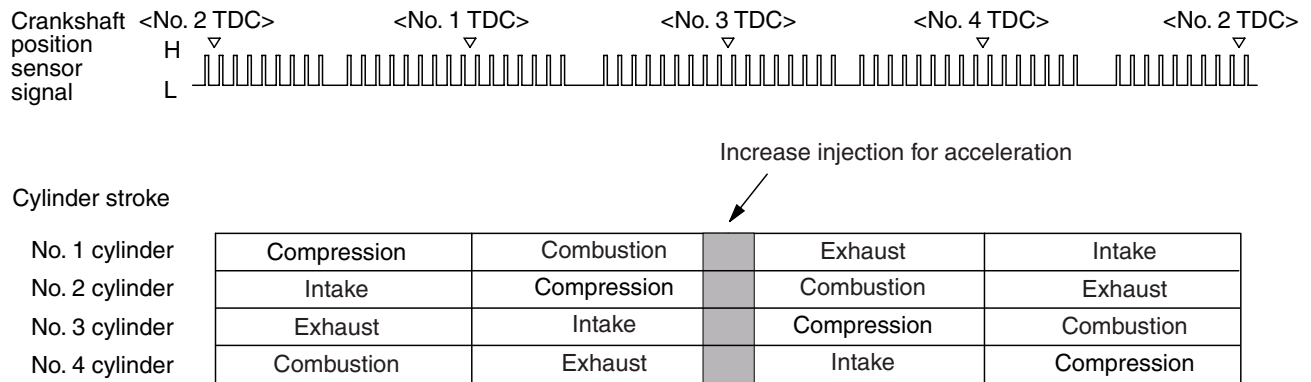

AK703786 AC

In addition to the synchronizing fuel injection with crankshaft position sensor signal during acceleration, the volume of fuel is injected according to the extent of the acceleration.



## 2. Fuel injection volume (injector drive time) control

The figure shows the flow for injector drive time calculation. Basic drive time is decided based on the mass airflow sensor signal (intake air volume signal) and crankshaft position sensor signal (engine rotation signal). This basic drive time is compensated according to signals from various sensors and optimum injector drive time (fuel injection volume) is calculated according to driving conditions.

### Fuel Injection Volume Control Block Diagram

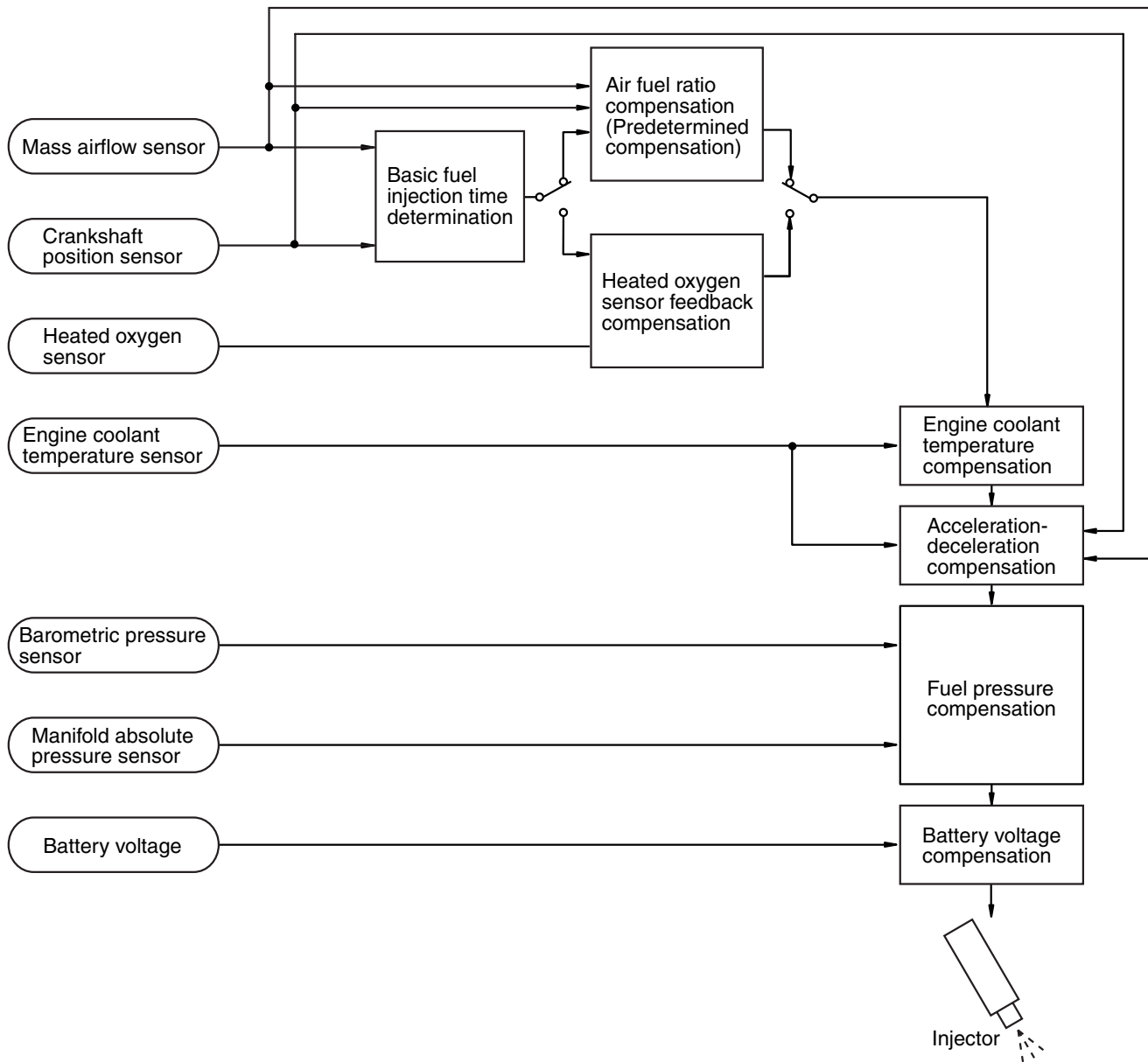

**[Injector basic drive time]**

Fuel injection is performed once per cycle for each cylinder. Basic drive time refers to fuel injection volume (injector drive time) to achieve theoretical air-fuel ratio for the intake air volume of 1 cycle of 1 cylinder. Fuel injection volume changes according to the pressure difference (injected fuel pressure) between manifold absolute pressure and fuel pressure (constant). So, injected fuel pressure compensation is made to injector drive time for theoretical air-fuel ratio to arrive at basic drive time.

$$\text{Basic fuel injection time} \propto \frac{\text{Intake air amount per cycle per cylinder}}{\text{Theoretical air-fuel ratio}} \times \text{Fuel injection pressure compensation}$$

AK602279AC

Intake air volume of each cycle of 1 cylinder is calculated by ECM based on the mass airflow sensor signal and crankshaft position sensor signal. Also, during engine start, the map value prescribed by the engine coolant temperature sensor signal is used as basic drive time.

**[Injector drive time compensation]**

After calculating the injector basic drive time, the ECM makes the following compensations to control the optimum fuel injection volume according to driving conditions.

**List of main compensations for fuel injection control**

Compensations	Content
Heated oxygen sensor feedback compensation	The heated oxygen sensor signal is used for making the compensation to get air-fuel ratio with best cleaning efficiency of the 3-way catalytic converter. This compensation might not be made sometimes in order to improve drivability, depending on driving conditions. (Air-fuel ratio compensation is made.) The ECM compensates the output signal of the heated oxygen sensor (front) using the output signal of the heated oxygen sensor (rear). This allows the deviation of the output signal, caused by the deterioration of the heated oxygen sensor (front), to be solved, then the highly accurate exhaust gas control is performed.
Air-fuel ratio compensation	Under driving conditions where heated oxygen sensor feedback compensation is not performed, compensation is made based on pre-set map values that vary according to engine speed and intake air volume.
Engine coolant temperature compensation	Compensation is made according to the engine coolant temperature. The lower the engine coolant temperature, the greater the fuel injection volume.
Acceleration/ Deceleration compensation	Compensation is made according to change in intake air volume. During acceleration, fuel injection volume is increased. Also, during deceleration, fuel injection volume is decreased.
Intake air temperature compensation	Compensation is made according to the intake air temperature. The lower the intake air temperature, the greater the fuel injection volume.
Barometric pressure compensation	Compensation is made according to the barometric pressure. The lower the barometric pressure, the smaller the fuel injection volume.
Battery voltage compensation	Compensation is made depending on battery voltage. The lower the battery voltage, the greater the injector drive signal time.
Learning value for fuel compensation	Compensation amount is learned to compensate feedback of heated oxygen sensor. This allows system to compensate in accordance with engine characteristics.

**[Fuel limit control during deceleration]**

ECM limits fuel when decelerating downhill to prevent excessive rise of catalytic converter temperature and to improve fuel efficiency.

**[Fuel-cut control when over-run]**

When engine speed exceeds a prescribed limit (6,600 r/min), ECM cuts fuel supply to prevent overrunning and thus protect the engine.

# IGNITION TIMING AND CONTROL FOR CURRENT CARRYING TIME

M2132027100476

Ignition timing is pre-set according to engine driving conditions. Compensations are made according to pre-set values depending on conditions such as engine coolant temperature, battery voltage etc. to decide optimum ignition timing. Primary current connect/disconnect signal is sent to the power transistor to control ignition timing. Ignition is done in sequence of cylinders 1, 3, 4, 2.

## System Configuration Diagram

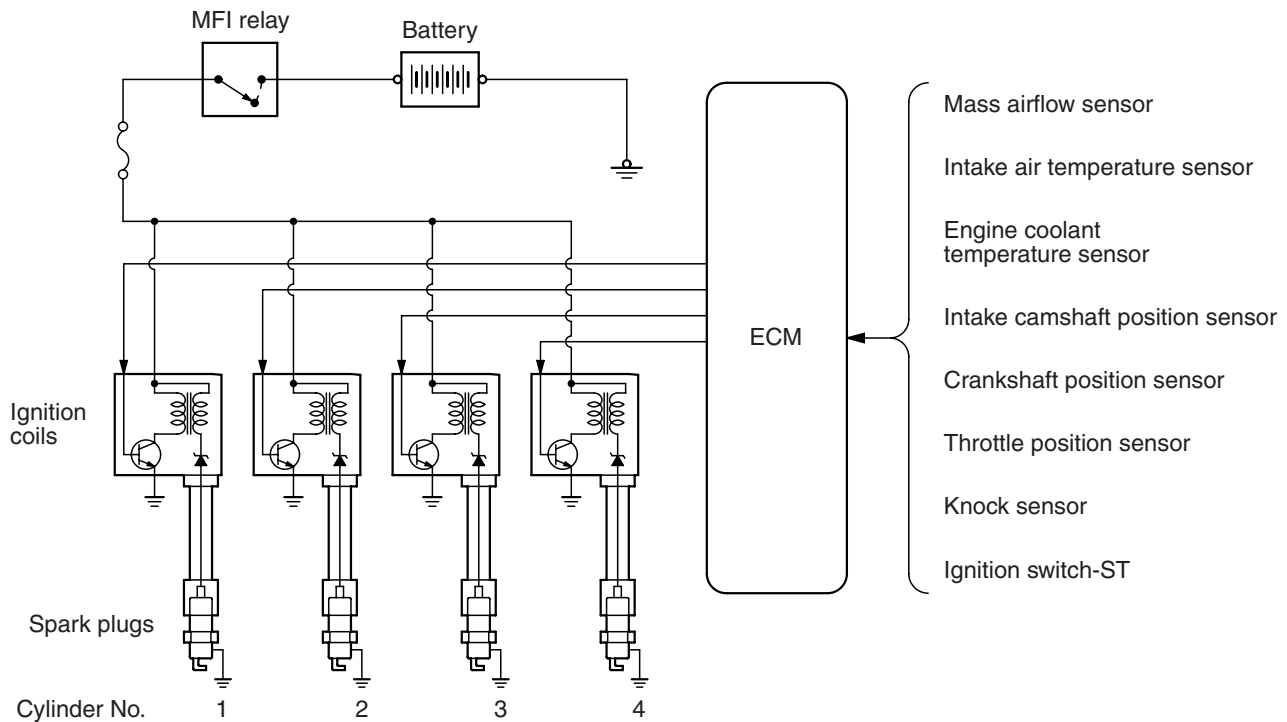

AK502722AM

## 1. Ignition distribution control

Based on the crankshaft position sensor signal and intake camshaft position sensor signal, ECM decides the ignition cylinder, calculates the ignition timing and sends the ignition coil primary current connect/disconnect signal to the power transistor of each cylinder in the ignition sequence.

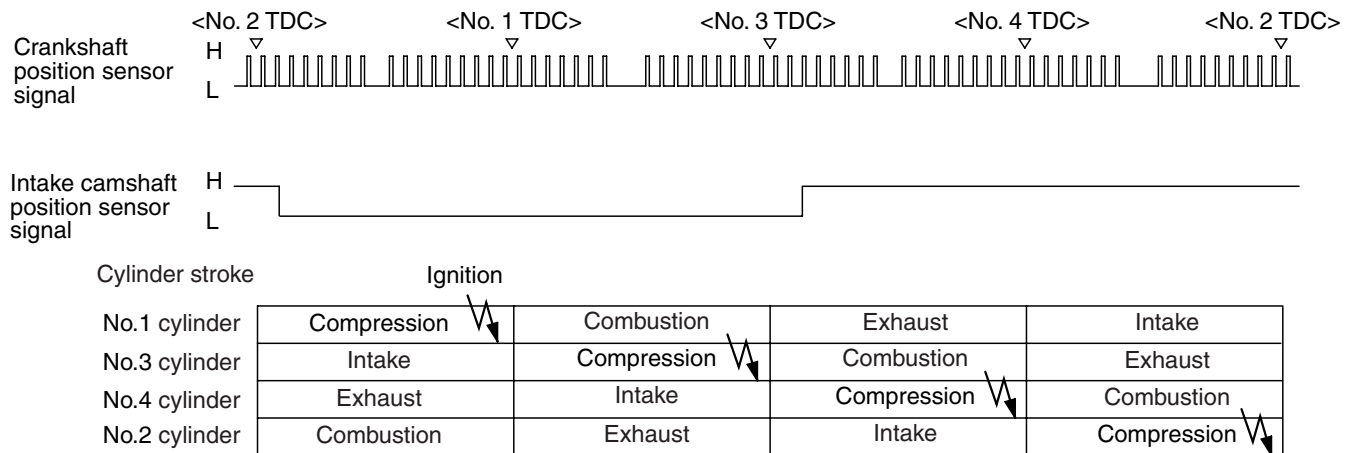

AK703693AC

## 2. Spark-advance control and current carrying time control

### [During start]

ECM initiates ignition at fixed ignition timing (5° BTDC) synchronized with the crankshaft position sensor signal.

### [During normal operation]

After determining the basic spark-advance based on the intake air volume and engine speed, ECM makes compensations based on input from various sensors to control the optimum spark-advance and current carrying time.

### List of main compensations for spark-advance control and current carrying time control

Compensations	Content
Intake air temperature compensation	Compensation is made according to intake air temperature. The higher the intake air temperature the greater the delay in ignition timing.
Engine coolant temperature compensation	Compensation is made according to engine coolant temperature. The lower the engine coolant temperature the greater the advance in ignition timing.
Knocking compensation	Compensation is made according to generation of knocking. The greater the knocking the greater the delay in ignition timing.

Compensations	Content
Stable idle compensation	Compensation is made according to change in idle speed. In case engine speed becomes lower than target speed, ignition timing is advanced.
Delay compensation when changing shift	During change of shift, sparking is delayed compared to normal ignition timing to reduce engine output torque and absorb the shock of the shift change.
Battery voltage compensation	Compensation is made depending on battery voltage. The lower the battery voltage the greater the current carrying time and when battery voltage is high current carrying time is shortened.

**[Control for checking ignition timing]**

During basic ignition timing set mode for M.U.T.-III actuator test function, sparking is done with fixed ignition timing (5° BTDC) synchronized with crankshaft position sensor signal.

# THROTTLE VALVE OPENING ANGLE CONTROL AND IDLE SPEED CONTROL

M2132003500823

ECM detects the amount of accelerator pedal depression (as per operator's intention) through the accelerator pedal position sensor. Based on pre-set basic target opening angles it adds various compensations and controls the throttle valve opening angle according to the target opening angle.

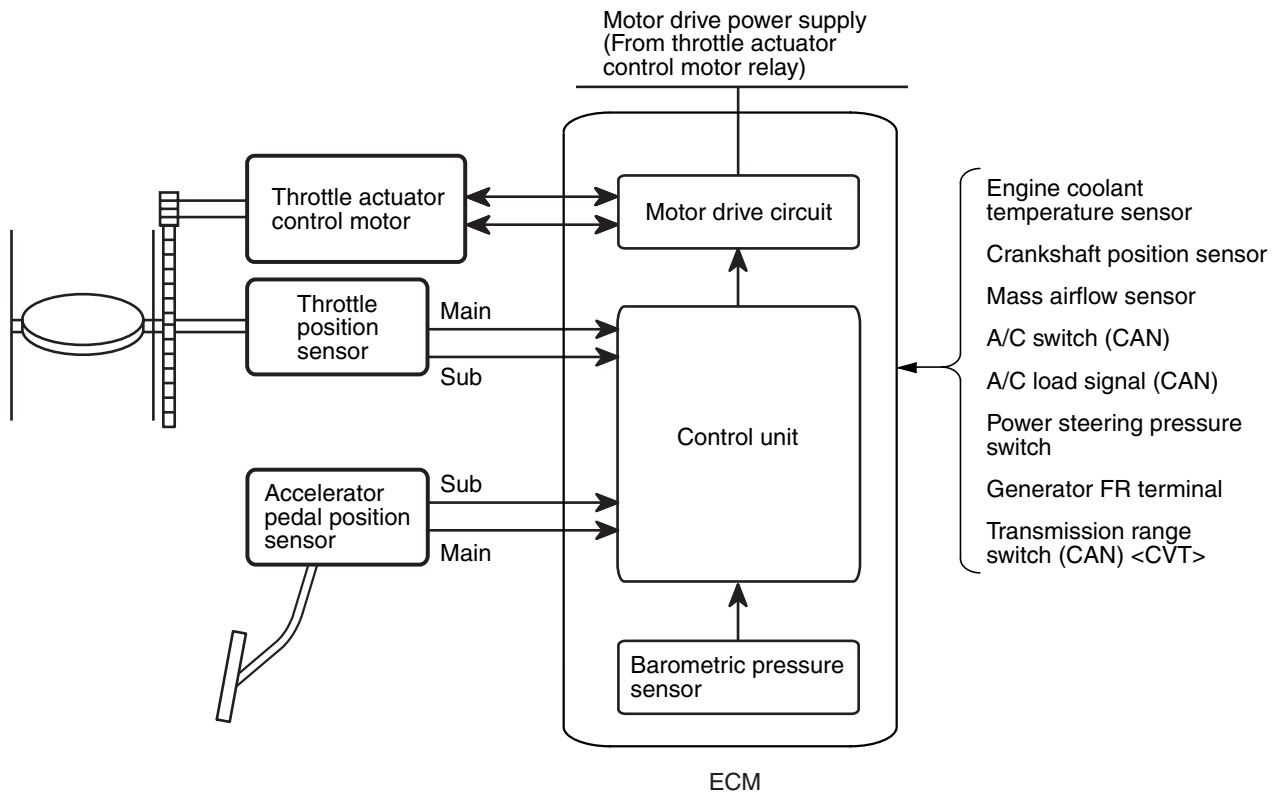

AK602236AO

## While starting

ECM adds various compensations to the target opening angle that are set based on the engine coolant temperature, so that the air volume is optimum for starting.

## While idling

ECM controls the throttle valve to achieve the target opening angle that are set based on the engine coolant temperature. In this way best idle operation is achieved when engine is cold and when it is hot. Also, the following compensations ensure optimum control.

## While driving

Compensations are made to the target opening angle set according to the accelerator pedal opening angle and engine speed to control the throttle valve opening angle.

**List of main compensations for throttle valve opening angle and idle speed control**

Compensations	Content
Stable idle compensation (immediately after start)	In order to stabilize idle speed immediately after start, target opening angle is kept big and then gradually reduced. Compensation values are set based on the engine coolant temperature.
Engine speed feedback compensation (while idling)	In case there is a difference between the target idle speed and actual engine speed, ECM compensates the throttle valve opening angle based on that difference.
Barometric pressure compensation	At high altitudes barometric pressure is less and the intake air density is low. So, the target opening angle is compensated based on barometric pressure.
Engine coolant temperature compensation	Compensation is made according to the engine coolant temperature. The lower the engine coolant temperature the greater the throttle valve opening angle.
Electric load compensation	Throttle valve opening angle is compensated according to electric load. The greater the electric load, the greater the throttle valve opening angle.
Compensation when shift is in D range <CVT>	When shift lever is changed from P or N range to some other range, throttle valve opening angle is increased to prevent reduction in engine speed.
Compensation when A/C is functioning	Throttle valve opening angle is compensated according to functioning of A/C compressor. While A/C compressor is being driven, the throttle valve opening angle is increased.
Power steering fluid pressure compensation	Throttle valve opening angle is compensated according to power steering functioning. When power steering oil pressure rises and power steering pressure switch is ON, the throttle valve opening angle is increased.

**Initialize control**

After ignition switch turns OFF, ECM drives the throttle valve from fully closed position to fully open position and records the fully closed/open studied value of the throttle position sensor (main and sub) output signals. The recorded studied values are used as studied value compensation for compensating basic target opening angle when the engine is started next.

**Engine protection control**

When the racing is continued during the vehicle stopped period (no-load period) for more than the specified time, the ECM closes the throttle valve and restricts the engine speed to protect the engine.



# MIVEC (Mitsubishi Innovative Valve Timing Electronic Control System)

M2132023500836

MIVEC is a control system continuously varying the intake valve timing and exhaust valve timing. The valve operating angle is not changed.

MIVEC enables valve timing control that is optimal for the operating conditions of the engine. Thus, it stabilizes the idle and improves power output and torque in all driving ranges.

## System Configuration Diagram

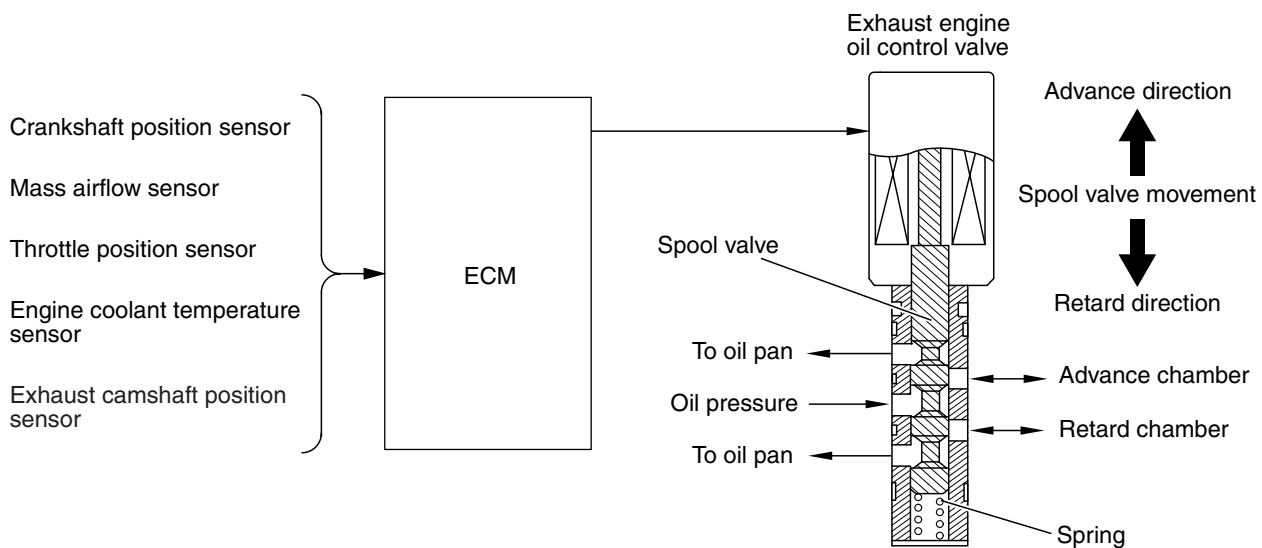
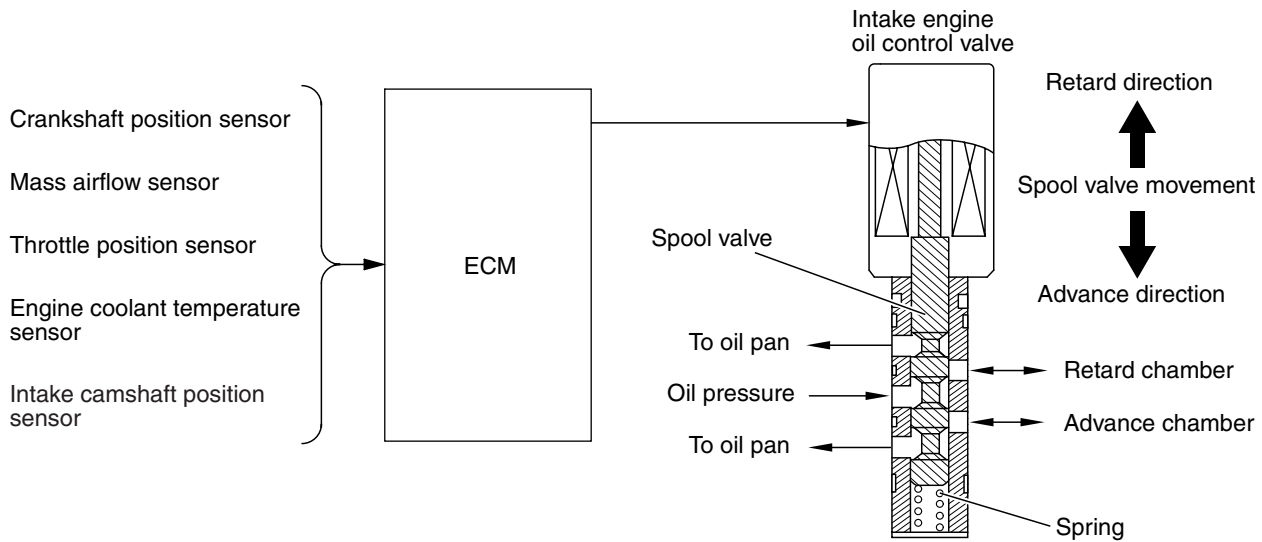

- The ECM assesses the engine operation through the signals from each sensor.

- Based on the assessed information, the ECM outputs duty cycle signals to the intake engine oil control valve and exhaust engine oil control valve in order to control the position of the spool valve.
- By varying the position of the spool valve, the oil pressure can be applied either to the retard or advance chamber, thus continuously changing the phases of the intake camshaft and exhaust camshaft.

**Phase Angle Detection**

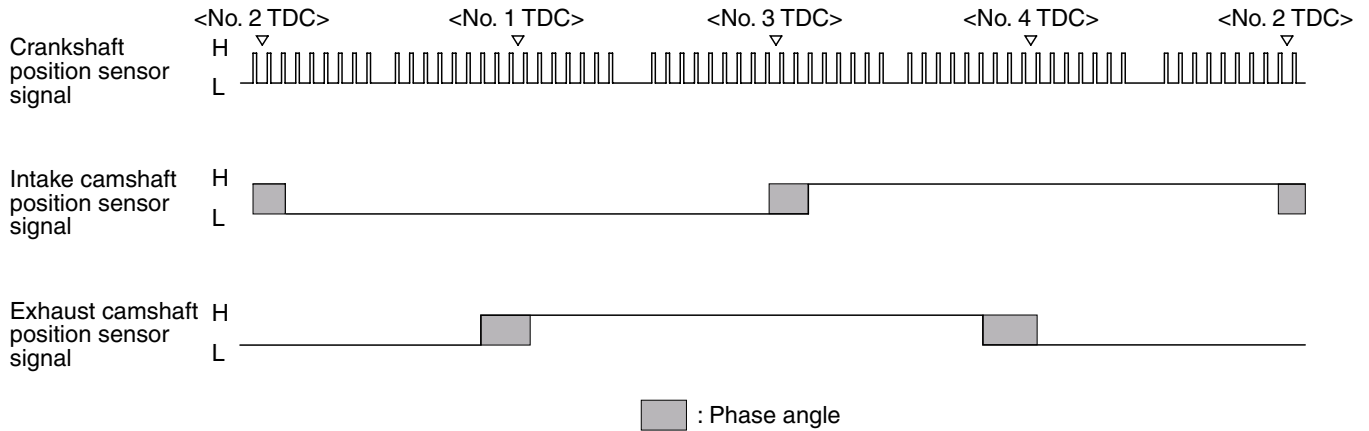

AK703694 AC

The detected phase angle is calculated using the intake camshaft position sensor signal and the exhaust camshaft position sensor signal.

The detected phase angle is calculated using the cam position sensor signal.

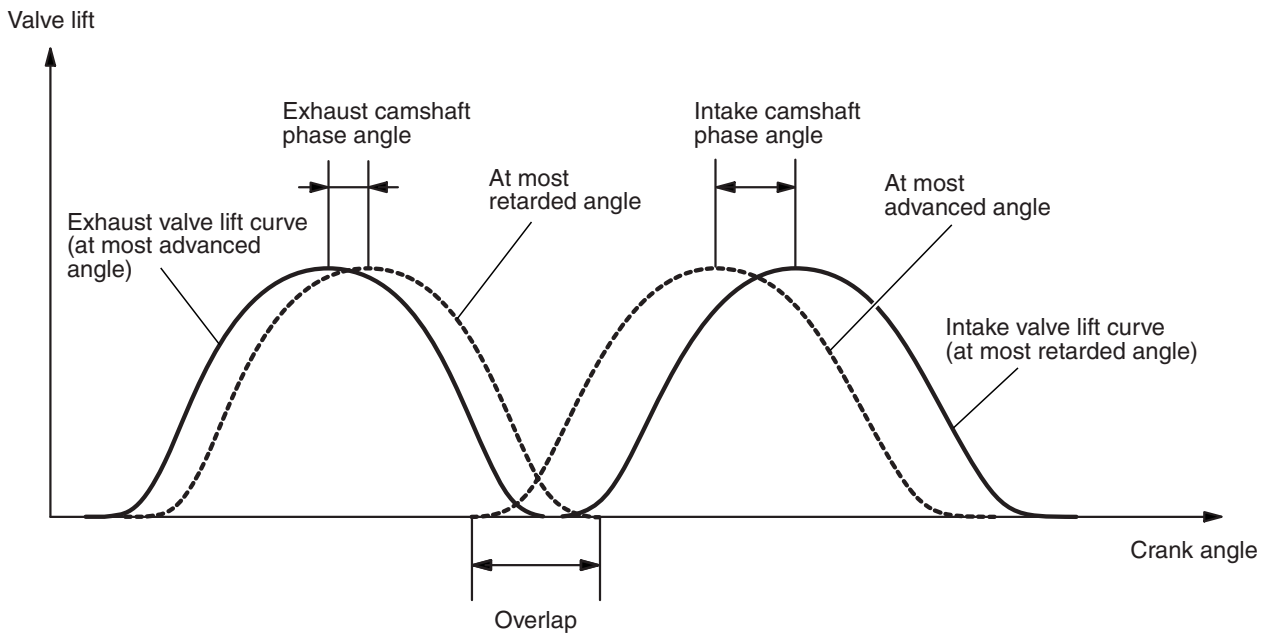

AK800023AC

The ECM controls the camshaft phase angle in order to attain optimal valve timing that suits the engine load and engine speed.

	Initial phase	Control direction
Intake side	Most retarded angle	Advance direction
Exhaust side	Most advanced angle	Retard direction

# MULTIPOINT FUEL INJECTION (MFI) RELAY CONTROL

M2132006000667

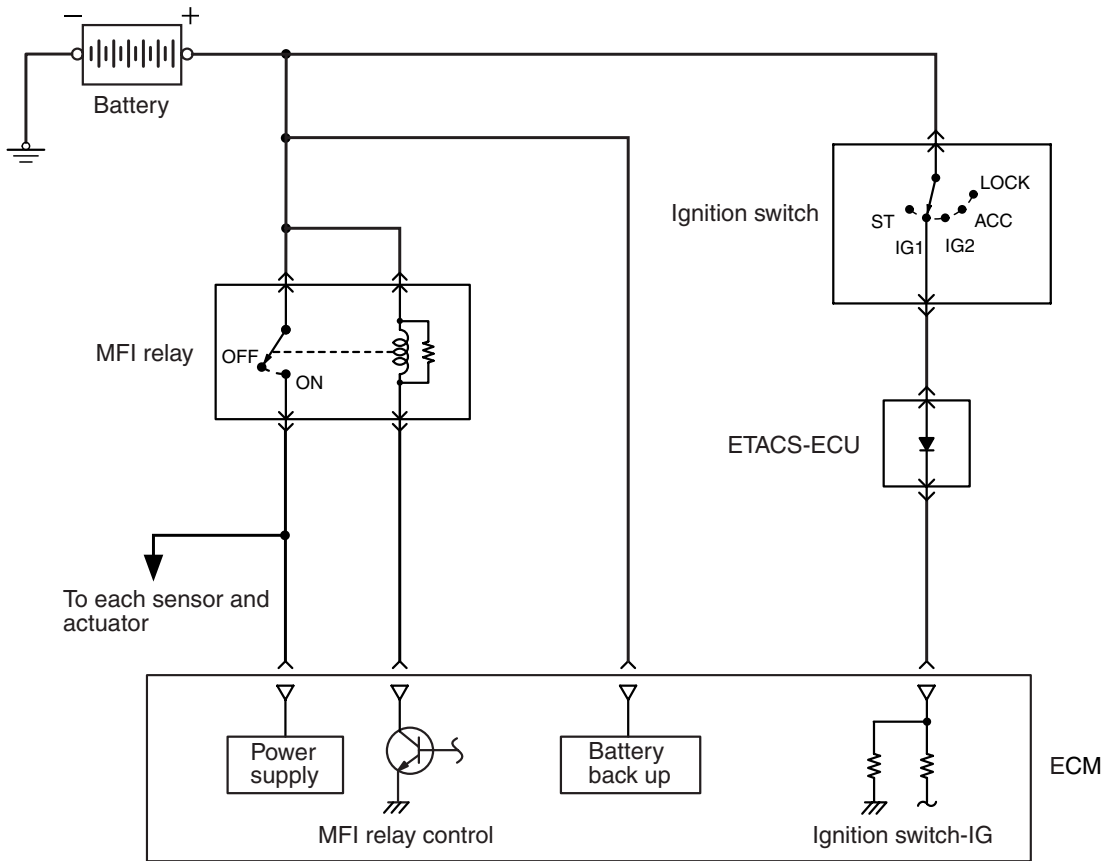

AK604134AB

When the ignition switch-IG "ON" signal is input, ECM turns ON the power transistor for control of the MFI relay. As a result, current flows through the MFI relay's coil, the relay switch turns ON and power is supplied to each sensor and actuator. Also, when ignition switch-IG "OFF" signal is input, ECM performs the following controls and then turns OFF the power transistor for control of MFI relay.

- Throttle valve initializing control

# FUEL PUMP RELAY CONTROL

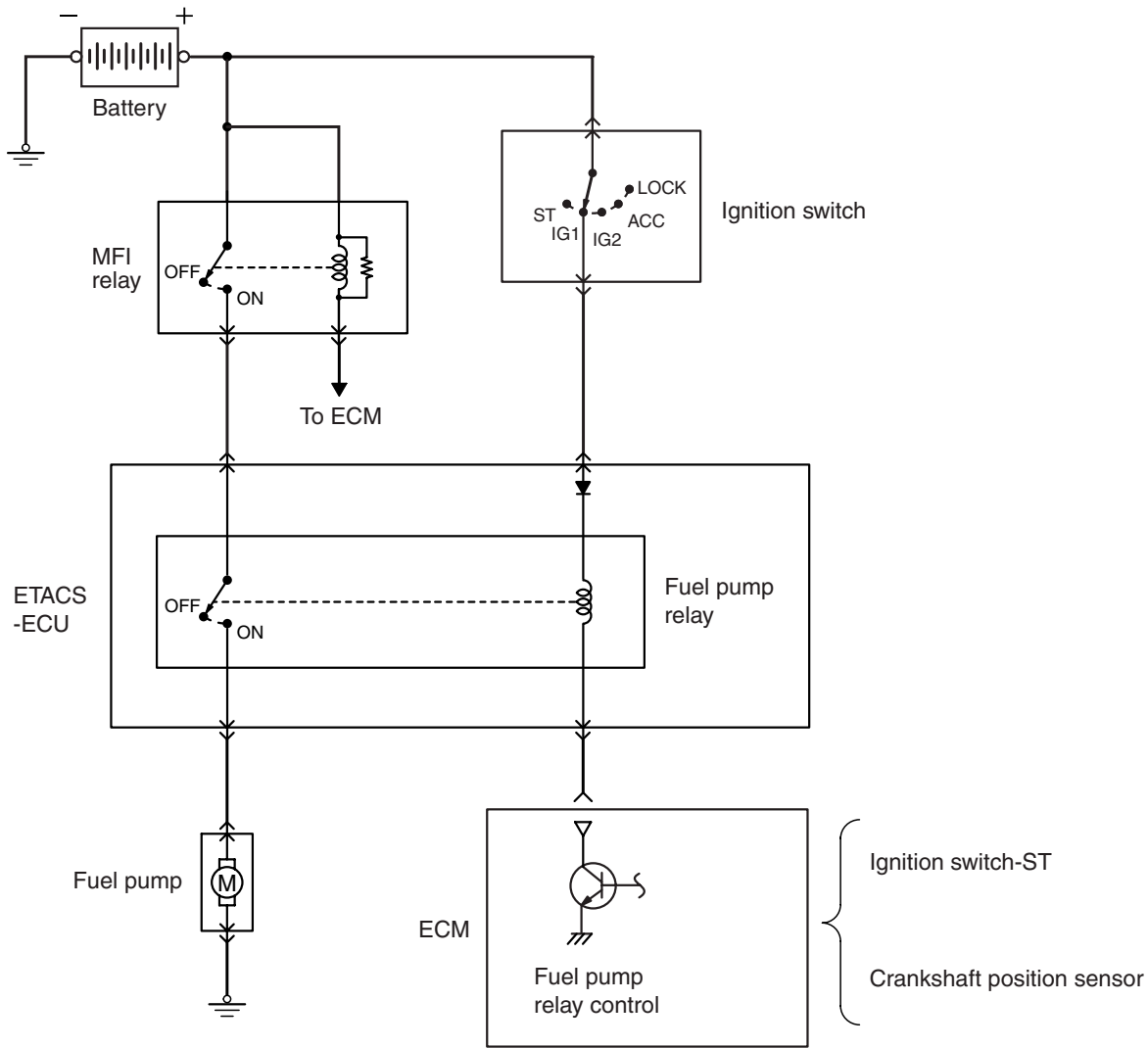

AK604135 AB

When current flows through the fuel pump relay, the relay turns ON and the fuel pump is driven. The fuel pump relay is built into the ETACS-ECU. When the ignition switch-ST signal is input, ECM turns ON the power transistor for control of the fuel pump relay. As

a result, power is supplied to the fuel pump. Also, if engine speed falls below a set value, the fuel pump relay is turned OFF. Thus, it deals with sudden stoppages such as engine stalling etc. by stopping the pump.

# STARTER RELAY CONTROL

M2132025500597

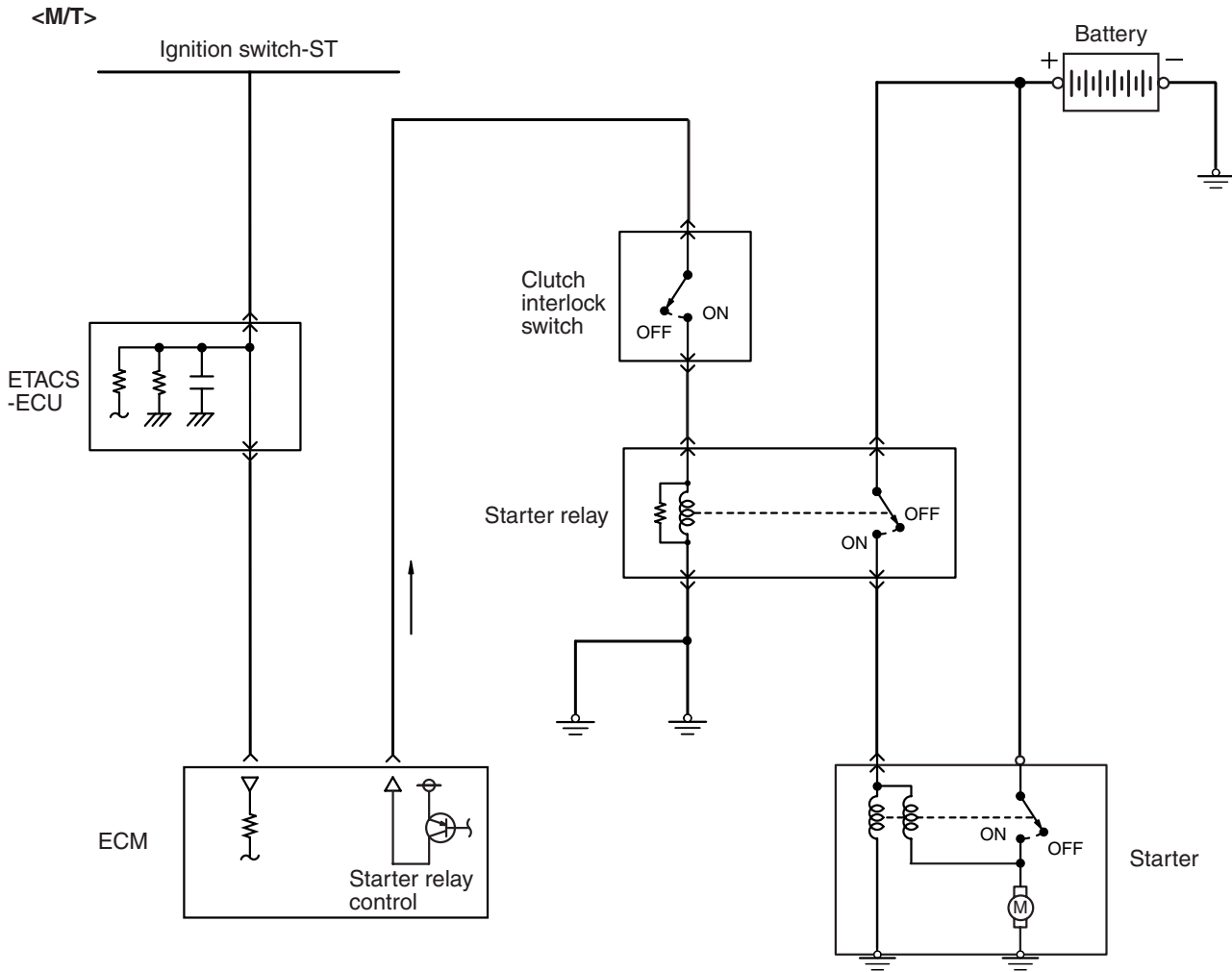

AK604136 AC

<CVT>

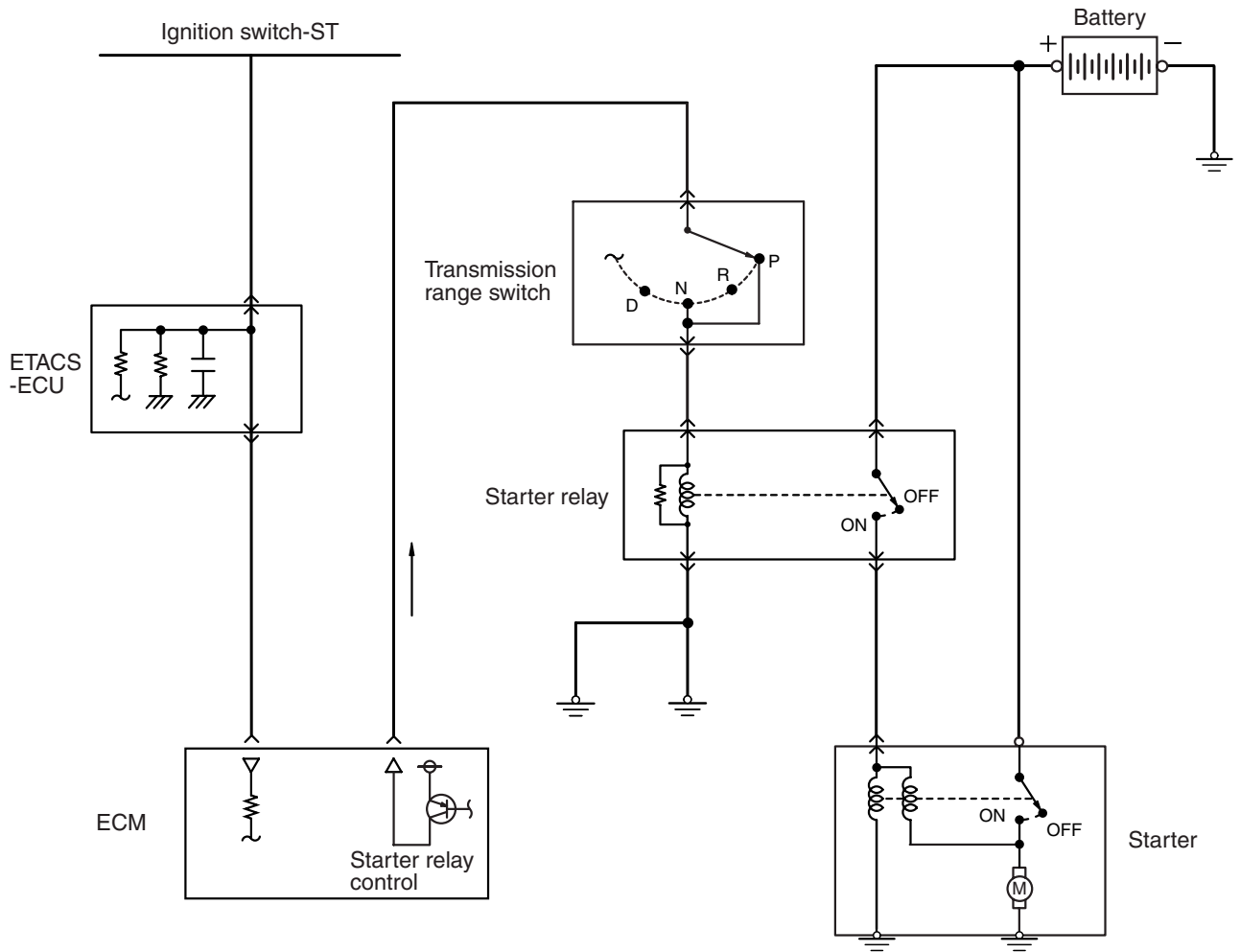

AK604137 AC

When the ignition switch-ST signal is input, ECM turns ON the power transistor for control of the starter relay.

## HEATED OXYGEN SENSOR HEATER CONTROL

M2132007000671

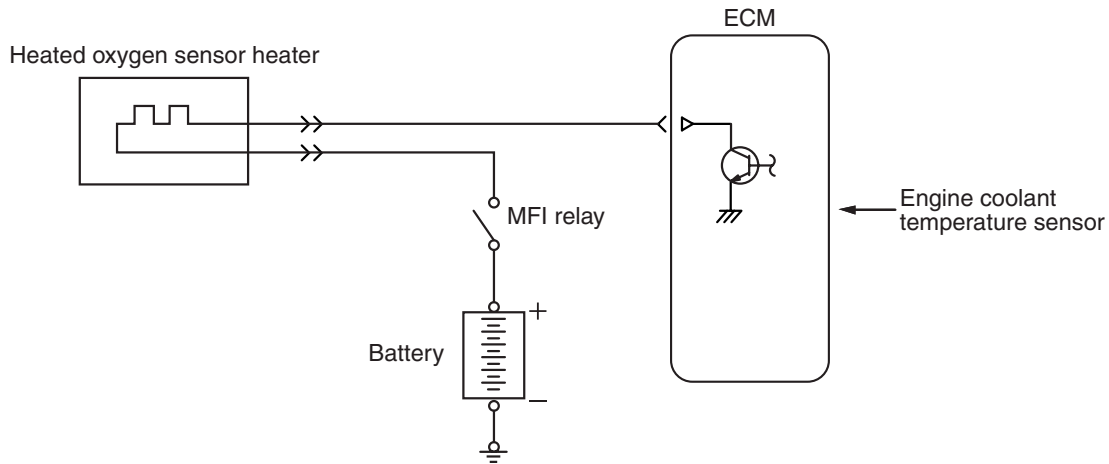

AK602241 AD

When exhaust gas temperature is low, the heated oxygen sensor response is dull. So, response is improved by raising the sensor temperature by passing current through the heater at a low exhaust gas temperature, such as in the immediate aftermath of the engine start, or during the warm up operation and

in cutting the fuel during deceleration. Based on driving conditions and the heated oxygen sensor activation state, ECM changes the amount of current (duty ratio) to the heater to quicken the activation of the heated oxygen sensor.



# A/C COMPRESSOR CLUTCH RELAY CONTROL

M2132027700025

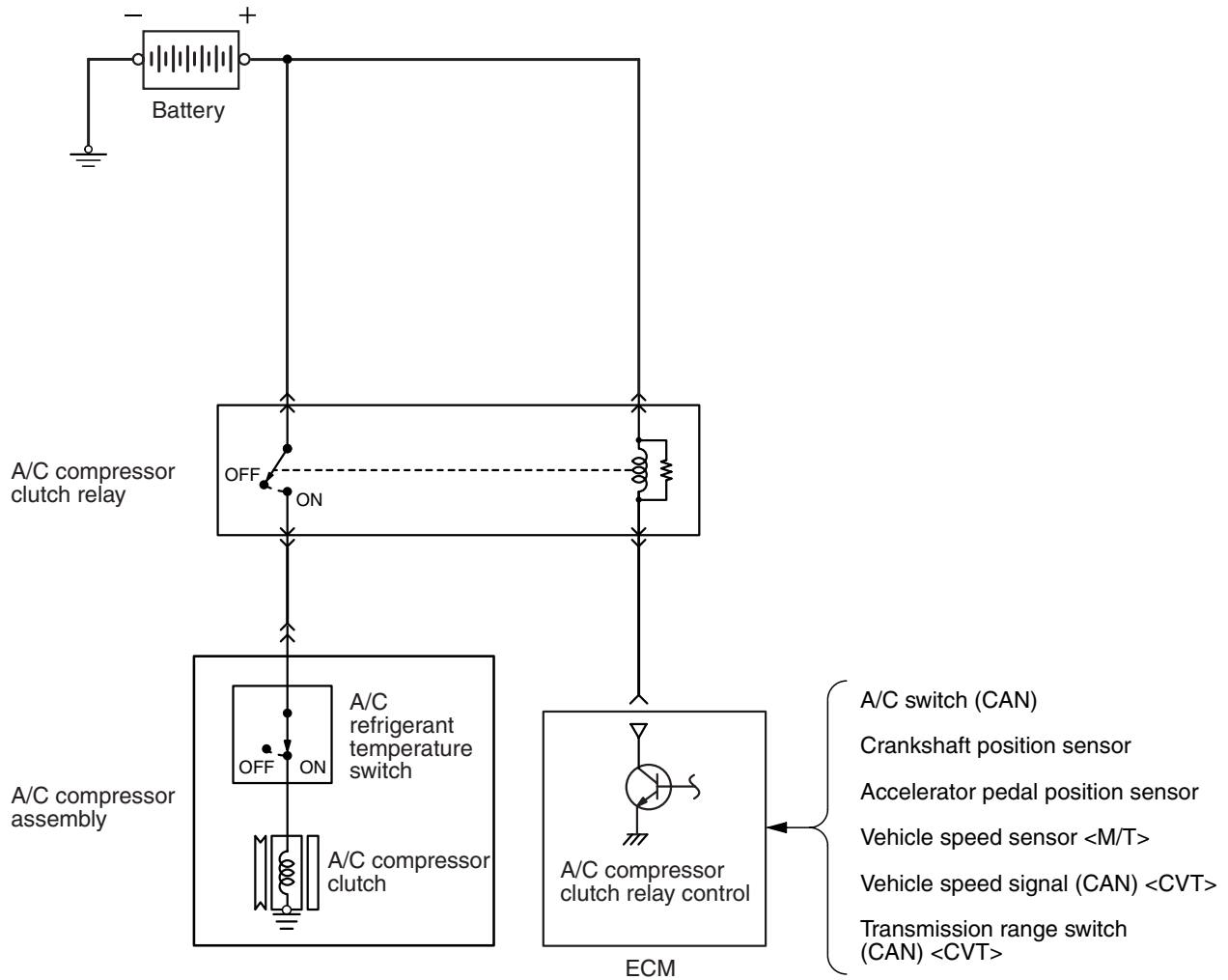

AK800141 AE

After the A/C switch is turned ON and A/C compressor clutch relay reaches a state where it can turn ON, ECM turns ON the A/C compressor clutch relay and drives the A/C compressor. In order to prevent change in engine speed due to increased load of driving the compressor, it controls the A/C compres-

or clutch relay to drive the A/C compressor after idle-up is complete. Also, in order to secure acceleration performance, it turns OFF the A/C compressor clutch relay for a fixed amount of time, if the throttle opening angle increases beyond a prescribed limit.

## GENERATOR CONTROL

M2132025000666

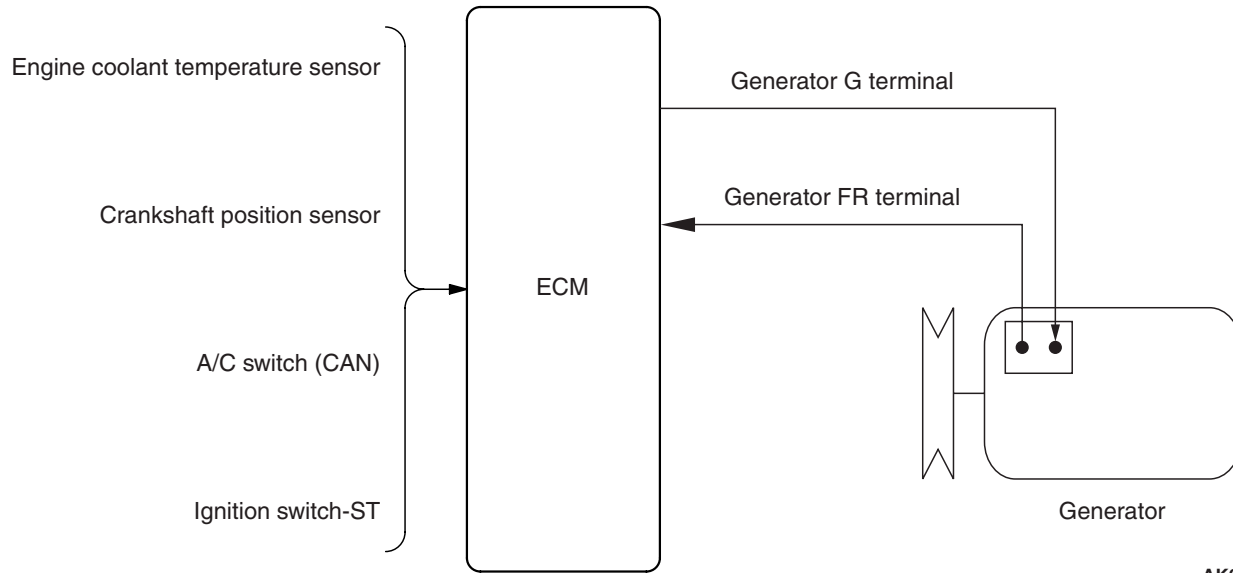

AK602242AD

During the engine idle operation, the ECM carries out the duty control for the electrical continuity between the generator G terminal and the ground. (At that time, the G terminal duty is controlled to be the same as the ON duty of the power transistor inside the voltage regulator.) If the head lights etc. are turned on while the engine is idling, the consumed current, so-called the engine load by the generator, increases.

When detecting the electrical load signal inputted into the generator FR terminal, the ECM increases gradually the generator G terminal OFF duty. The ECM compensates the throttle open degree according to the electrical load, restricting the sudden increase in the engine load by the generator. The battery current is supplied to the headlamp etc. till the engine idles steadily. Thus, the ECM stabilizes the idling speed.

## EVAPORATIVE EMISSION PURGE CONTROL

Refer to GROUP 17 –Emission Control –Evaporative Emission Control System P.17-15.

## EVAPORATIVE EMISSION CONTROL SYSTEM INCORRECT PURGE FLOW MONITOR

M2132027200075

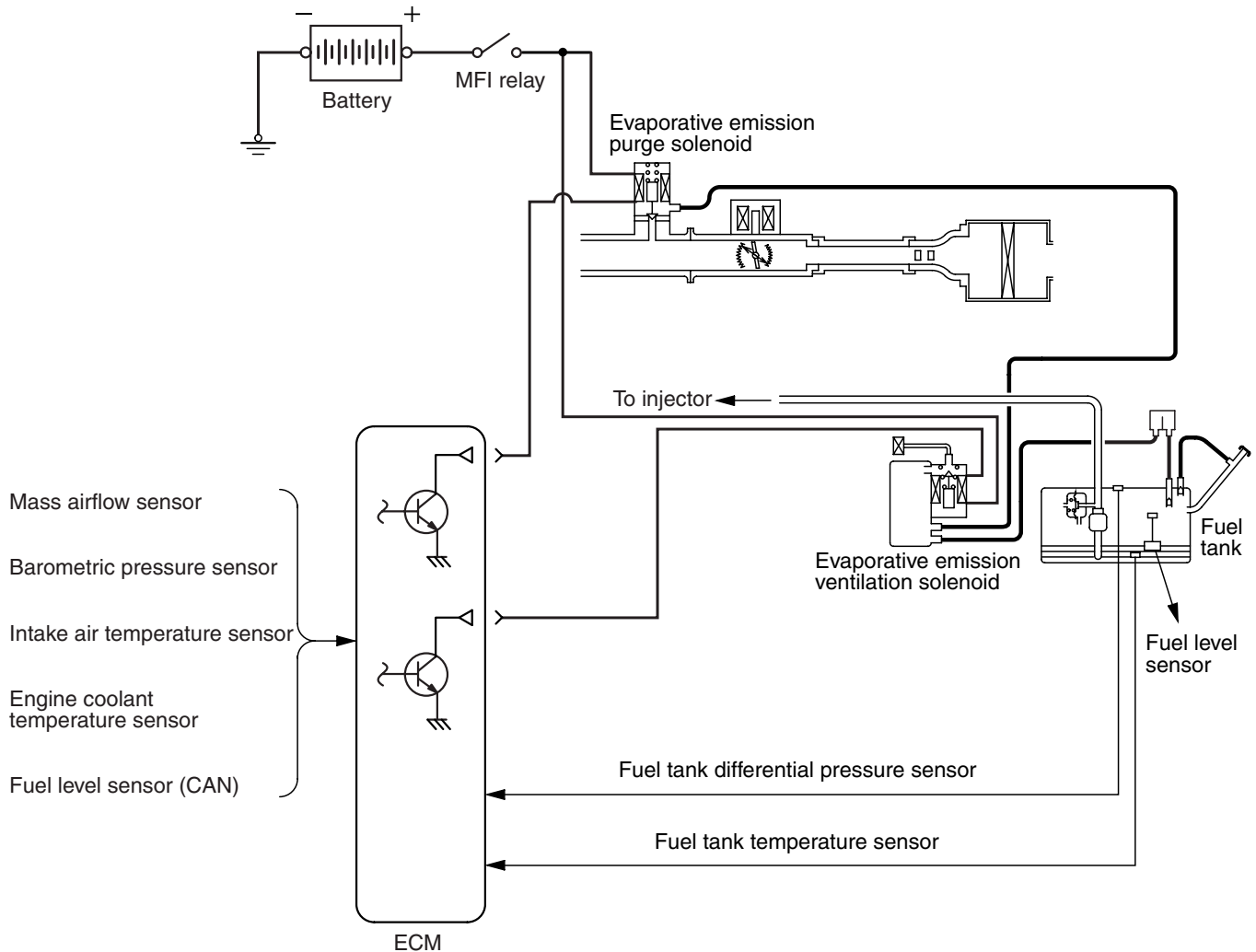

AK900507 AB

The ECM detects whether the fuel vapor leakage exists or not from the evaporative emission control system. By the specified pattern within the certain operation range, the ECM drives the evaporative emission purge solenoid and the evaporative emission ventilation solenoid. This allows slight vacuum to be produced in the fuel tank.

The ECM measures the vacuum condition through the fuel tank differential pressure sensor signal. By comparing the normal (expected) value and the actual value, the ECM detects whether the fuel vapor leakage exists or not from the evaporative emission control system.

## **EXHAUST GAS RECIRCULATION CONTROL**

M2132016000334

Refer to GROUP 17 –Emission Control –Exhaust Gas Recirculation (EGR) System <2.4L ENGINE> [P.17-18](#).

## **CONTROLLER AREA NETWORK (CAN)**

M2132019000872

CAN communication is established to ensure the reliable transmission of information. Refer to GROUP 54C –General Information [P.54C-2](#).

## **HC TRAP CATALYTIC CONVERTER DETERIORATION MONITOR**

M2132027300038

Refer to GROUP 17 –Emission Control –Emission Reduction System [P.17-19](#).

## ON-BOARD DIAGNOSTICS

M2132009001830

The engine control module (ECM) has been provided with the following functions for easier system inspection.

### Diagnostic Trouble Codes and Malfunction Indicator Lamp (SERVICE ENGINE SOON or Check Engine Lamp) Function

The diagnostic trouble code and malfunction indicator lamp (SERVICE ENGINE SOON or Check Engine Lamp) items are shown in the following table.

NOTE: \*1: Diagnostic Trouble Code

NOTE: \*2: Malfunction Indicator Lamp

DTC*1	DIAGNOSTIC ITEM	MIL*2 ITEM
–	Engine control module (ECM)	×
P0010	Intake engine oil control valve circuit	×
P0011	Intake variable valve timing system target error	×
P0013	Exhaust engine oil control valve circuit	×
P0014	Exhaust variable valve timing system target error	×
P0016	Crankshaft/camshaft (intake) position sensor phase problem	×
P0017	Crankshaft/camshaft (exhaust) position sensor phase problem	×
P0031	Heated oxygen sensor (front) heater control circuit low	×
P0032	Heated oxygen sensor (front) heater control circuit high	×
P0037	Heated oxygen sensor (rear) heater control circuit low	×
P0038	Heated oxygen sensor (rear) heater control circuit high	×
P0043	Heated oxygen sensor (3rd) heater control circuit low <Vehicles for California>	×
P0044	Heated oxygen sensor (3rd) heater control circuit high <Vehicles for California>	×
P0069	Abnormal correlation between manifold absolute pressure sensor and barometric pressure sensor	×
P0101	Mass airflow circuit range/performance problem	×
P0102	Mass airflow circuit low input	×
P0103	Mass airflow circuit high input	×
P0106	Manifold absolute pressure circuit range/performance problem	×
P0107	Manifold absolute pressure circuit low input	×
P0108	Manifold absolute pressure circuit high input	×
P0111	Intake air temperature circuit range/performance problem	×
P0112	Intake air temperature circuit low input	×
P0113	Intake air temperature circuit high input	×
P0116	Engine coolant temperature circuit range/performance problem	×
P0117	Engine coolant temperature circuit low input	×
P0118	Engine coolant temperature circuit high input	×
P0122	Throttle position sensor (main) circuit low input	×

DTC*1	DIAGNOSTIC ITEM	MIL*2 ITEM
P0123	Throttle position sensor (main) circuit high input	×
P0125	Insufficient coolant temperature for closed loop fuel control	×
P0128	Coolant thermostat (coolant temperature below thermostat regulating temperature)	×
P0131	Heated oxygen sensor (front) circuit low voltage	×
P0132	Heated oxygen sensor (front) circuit high voltage	×
P0133	Heated oxygen sensor (front) circuit slow response	×
P0134	Heated oxygen sensor (front) circuit no activity detected	×
P0137	Heated oxygen sensor (rear) circuit low voltage	×
P0138	Heated oxygen sensor (rear) circuit high voltage	×
P0139	Heated oxygen sensor (rear) circuit slow response	×
P0140	Heated oxygen sensor (rear) circuit no activity detected	×
P0143	Heated oxygen sensor (3rd) circuit low voltage <Vehicles for California>	×
P0144	Heated oxygen sensor (3rd) circuit high voltage <Vehicles for California>	×
P0145	Heated oxygen sensor (3rd) circuit slow response <Vehicles for California>	×
P0146	Heated oxygen sensor (3rd) circuit no activity detected <Vehicles for California>	×
P0171	System too lean	×
P0172	System too rich	×
P0181	Fuel tank temperature sensor circuit range/performance	×
P0182	Fuel tank temperature sensor circuit low input	×
P0183	Fuel tank temperature sensor circuit high input	×
P0201	Injector circuit-cylinder 1	×
P0202	Injector circuit-cylinder 2	×
P0203	Injector circuit-cylinder 3	×
P0204	Injector circuit-cylinder 4	×
P0222	Throttle position sensor (sub) circuit low input	×
P0223	Throttle position sensor (sub) circuit high input	×
P0300	Random/multiple cylinder misfire detected	×
P0301	Cylinder 1 misfire detected	×
P0302	Cylinder 2 misfire detected	×
P0303	Cylinder 3 misfire detected	×
P0304	Cylinder 4 misfire detected	×
P0327	Knock sensor circuit low	×
P0328	Knock sensor circuit high	×
P0335	Crankshaft position sensor circuit	×
P0340	Intake camshaft position sensor circuit	×
P0365	Exhaust camshaft position sensor circuit	×

<b>DTC*1</b>	<b>DIAGNOSTIC ITEM</b>	<b>MIL*2 ITEM</b>
P0401	Exhaust gas recirculation flow insufficient detected	×
P0420	Warm up catalyst efficiency below threshold <Except vehicles for California>	×
P0421	Warm up catalyst efficiency below threshold <Vehicles for California>	×
P0441	Evaporative emission control system incorrect purge flow	×
P0442	Evaporative emission control system leak detected (small leak)	×
P0443	Evaporative emission control system purge control valve circuit	×
P0446	Evaporative emission control system vent control circuit	×
P0450	Evaporative emission control system pressure sensor malfunction	×
P0451	Evaporative emission control system pressure sensor range/performance	×
P0452	Evaporative emission control system pressure sensor low input	×
P0453	Evaporative emission control system pressure sensor high input	×
P0455	Evaporative emission control system leak detected (gross leak)	×
P0456	Evaporative emission control system leak detected (very small leak)	×
P0461	Fuel level sensor circuit range/performance	×
P0462	Fuel level sensor circuit low input	×
P0463	Fuel level sensor circuit high input	×
P0489	EGR valve (stepper motor) circuit malfunction (ground short)	×
P0490	EGR valve (stepper motor) circuit malfunction (battery short)	×
P0500	Vehicle speed sensor malfunction <M/T>	×
P0506	Idle control system RPM lower than expected	×
P0507	Idle control system RPM higher than expected	×
P050B	Ignition timing retard insufficient	×
P0513	Immobilizer malfunction	—
P0551	Power steering pressure switch circuit range/performance	×
P0554	Power steering pressure switch circuit intermittent	×
P0603	EEPROM malfunction	×
P0606	Engine control module main processor malfunction	×
P0622	Generator FR terminal circuit malfunction	—
P0630	Vehicle Identification Number (VIN) malfunction	×
P0638	Throttle actuator control motor circuit range/performance	×
P0642	Throttle position sensor power supply	×
P0657	Throttle actuator control motor relay circuit malfunction	×
P1231	Active stability control plausibility <Vehicles with ASC>	—
P1232	Fail safe system	—
P1233	Throttle position sensor (main) plausibility	×
P1234	Throttle position sensor (sub) plausibility	×
P1235	Mass airflow sensor plausibility	×

DTC*1	DIAGNOSTIC ITEM	MIL*2 ITEM
P1236	A/D converter	×
P1237	Accelerator pedal position sensor plausibility	×
P1238	Mass airflow sensor plausibility (torque monitor)	×
P1239	Engine RPM plausibility	×
P1240	Ignition angle	–
P1241	Torque monitor	×
P1242	Fail safe control monitor	–
P1243	Inquiry/response error	–
P1244	RAM test for all area	–
P1245	Cycle RAM test (engine)	–
P1247	CVT plausibility <CVT>	–
P1506	Idle control system RPM lower than expected at low temperature	×
P1507	Idle control system RPM higher than expected at low temperature	×
P1590	TCM to ECM communication error in torque reduction request <CVT>	×
P1603	Battery backup circuit malfunction	×
P1676	Variant coding	×
P2100	Throttle actuator control motor circuit (open)	×
P2101	Throttle actuator control motor magneto malfunction	×
P2122	Accelerator pedal position sensor (main) circuit low input	×
P2123	Accelerator pedal position sensor (main) circuit high input	×
P2127	Accelerator pedal position sensor (sub) circuit low input	×
P2128	Accelerator pedal position sensor (sub) circuit high input	×
P2135	Throttle position sensor (main and sub) range/performance problem	×
P2138	Accelerator pedal position sensor (main and sub) range/performance problem	×
P2195	Heated oxygen sensor (front) inactive	×
P2228	Barometric pressure circuit low input	×
P2229	Barometric pressure circuit high input	×
P2252	Heated oxygen sensor offset circuit low voltage	×
P2253	Heated oxygen sensor offset circuit high voltage	×
P2423	HC adsorber (HC trap catalyst) efficiency below threshold <Vehicles for California>	×
U0001	Bus off	–
U0101	TCM time-out <CVT>	×
U0121	ABS-ECU/ASC-ECU time-out	–
U0141	ETACS-ECU time-out	×
U0167	Immobilizer communication error	–
U1180	Combination meter time-out	×



**Data List Function**

The data list items are shown in the following table.

*NOTE: When M.U.T.-III is used, M.U.T.-III items appear alphabetically*

*NOTE: Data list items consist of M.U.T.-III items and GST items. GST items can be accessed through the use of a general scan tool.*

**M.U.T.-III Item**

<b>M.U.T.-III SCAN TOOL DISPLAY</b>	<b>ITEM NO.</b>	<b>INSPECTION ITEM</b>	<b>UNIT</b>
A/C compressor relay	93	A/C compressor clutch relay	ON/OFF
A/C SW	76	A/C switch	ON/OFF
Absolute load value	72	Absolute load value	%
Airflow sensor	10	Mass airflow sensor	mV
Airflow sensor	AA	Mass airflow sensor	g/s
APP sensor (main)	11	Accelerator pedal position sensor (main)	mV
APP sensor (main)	BE	Accelerator pedal position sensor (main)	%
APP sensor (sub)	12	Accelerator pedal position sensor (sub)	mV
APP sensor (sub)	BF	Accelerator pedal position sensor (sub)	%
Barometric pressure sensor	BB	Barometric pressure sensor	kPa (in.Hg)
Brake light switch	74	Brake light switch	ON/OFF
Calculated load value	73	Calculated load value	%
Closed throttle position switch	84	Closed throttle position signal	ON/OFF
Cranking signal	79	Cranking signal (ignition switch-ST)	ON/OFF
Crankshaft position sensor	2	Crankshaft position sensor	r/min
ECT sensor	6	Engine coolant temperature sensor	°C (°F)
EGR step motor	31	EGR valve (stepper motor)	Step
Engine control relay	95	MFI relay	ON/OFF
Engine oil pressure switch	90	Engine oil pressure switch	ON/OFF
ETV relay	96	Throttle actuator control motor relay	ON/OFF
EVAP. emission purge SOL. duty	49	Evaporative emission purge solenoid duty	%
Exhaust VVT angle (bank1)	39	Exhaust MIVEC phase angle	°CA
Fan duty	47	Fan motor duty	%
Fuel level gauge	51	Fuel level gauge	%
Fuel pump relay	97	Fuel pump relay	ON/OFF
Fuel system status (bank 1)	105	Fuel control system status	OL: CL INCOMP. / CL: Using O2S / OL: DRV condition / OL: System fail / CL: Using S O2S
Fuel system status (bank 2)*	106	–	–

M.U.T.-III SCAN TOOL DISPLAY	ITEM NO.	INSPECTION ITEM	UNIT
Fuel tank differential PRS. SNSR	52	Fuel tank differential pressure sensor	mV
Fuel tank temperature sensor	53	Fuel tank temperature sensor	°C (°F)
Ignition switch	85	Ignition switch (IG1)	ON/OFF
Injectors	17	Injectors	ms
Intake air temperature sensor 1	5	Intake air temperature sensor	°C (°F)
Intake VVT angle (bank1)	36	Intake MIVEC phase angle	°CA
ISC learned value (A/C OFF)	68	Idle speed control learned value (A/C OFF)	L/s
ISC learned value (A/C ON)	69	Idle speed control learned value (A/C ON)	L/s
Knock retard	32	Knock retard	°CA
Learned knock retard	33	Knock control learned value	%
Long term fuel trim (bank 1)	26	Long-term fuel trim	%
MAP sensor	8	Manifold absolute pressure sensor	kPa (in.Hg)
Neutral switch	87	Neutral switch <CVT>	ON/OFF
Normally closed brake switch	89	Normally closed brake switch	ON/OFF
Oxygen sensor (bank 1 sensor 1)	AC	Heated oxygen sensor (front)	V
Oxygen sensor (bank 1 sensor 2)	AD	Heated oxygen sensor (rear)	V
Oxygen sensor (bank 1 sensor 3)	B1	Heated oxygen sensor (3d) <Vehicles for California>	V
Power steering switch	83	Power steering pressure switch	ON/OFF
Power supply voltage	1	Power supply voltage	V
Relative APP sensor	DD	Relative accelerator pedal position sensor	%
Relative TP sensor	BC	Relative throttle position sensor	%
Short term fuel trim (bank 1)	28	Short-term fuel trim	%
Spark advance	16	Ignition timing advance	°CA
Starter relay	102	Starter relay	ON/OFF
Target EGR	BA	Target EGR valve (stepper motor)	%
Target ETV value	59	Throttle actuator control motor target value	V
Target idle speed	3	Target idle speed	r/min
Throttle actuator	58	Throttle actuator control motor	%
TP sensor (main)	13	Throttle position sensor (main)	mV
TP sensor (main)	AB	Throttle position sensor (main)	%
TP sensor (main) learned value	14	Throttle position sensor (main) mid opening learning value	mV
TP sensor (sub)	15	Throttle position sensor (sub)	mV
TP sensor (sub)	BD	Throttle position sensor (sub)	%
Vehicle speed	4	Vehicle speed	km/h (mph)

NOTE: \*:The item is only displayed, but not applied.

**GST Item**

PARAMETER IDENTIFICATION (PID)	DESCRIPTION	COMMON EXAMPLE OF GENERAL SCAN TOOL DISPLAY
01	Number of emission-related DTCs and MIL status	DTC and MIL status:
	# of DTCs stored in this ECU	DTC_CNT: xxxd
	Malfunction Indicator Lamp (MIL) status	MIL: OFF or ON
	Supported tests which are continuous	Support status of continuous monitors:
	Misfire monitoring supported	MIS_SUP: YES
	Fuel system monitoring supported	FUEL_SUP: YES
	Comprehensive component monitoring supported	CCM_SUP: YES
	Status of continuous monitoring tests since DTC cleared	Completion status of continuous monitors since DTC cleared:
	Misfire monitoring ready	MIS_RDY: YES or NO
	Fuel system monitoring ready	FUEL_RDY: YES or NO
	Comprehensive component monitoring ready	CCM_RDY: YES or NO
	Supported tests run at least once per trip	Support status of non-continuous monitors:
	Catalyst monitoring supported	CAT_SUP: YES
	Heated catalyst monitoring supported	HCAT_SUP: NO
	Evaporative system monitoring supported	EVAP_SUP: YES
	Secondary air system monitoring supported	AIR_SUP: NO
	Oxygen sensor monitoring supported	O2S_SUP: YES
	Oxygen sensor heater monitoring supported	HTR_SUP: YES
	EGR and/or VVT system monitoring supported	EGR_SUP: YES
	Status of tests run at least once per trip	Completion status of non-continuous monitors since DTC cleared:
	Catalyst monitoring ready	CAT_RDY: YES or NO
	Heated catalyst monitoring ready	HCAT_RDY: YES
	Evaporative system monitoring ready	EVAP_RDY: YES or NO
	Secondary air system monitoring ready	AIR_RDY: YES
	Oxygen sensor monitoring ready	O2S_RDY: YES or NO
	Oxygen sensor heater monitoring ready	HTR_RDY: YES or NO
	EGR and/or VVT system monitoring ready	EGR_RDY: YES or NO
	03	Fuel system 1 status
04	Calculated LOAD Value	LOAD_PCT: xxx.x%
05	Engine Coolant Temperature	ECT: xxx° C (xxx° F)

PARAMETER IDENTIFICATION (PID)	DESCRIPTION	COMMON EXAMPLE OF GENERAL SCAN TOOL DISPLAY
06	Short Term Fuel Trim-Bank 1	SHRTFT1: xxx.x %
07	Long Term Fuel Trim-Bank 1	LONGFT1: xxx.x %
0B	Intake Manifold Absolute Pressure	MAP: xxxx.x kPa (xxx.x inHg)
0C	Engine RPM	RPM: xxxxx min <sup>-1</sup>
0D	Vehicle Speed Sensor	VSS: xxx km/h (xxx mph)
0E	Ignition Timing Advance for #1 Cylinder	SPARKADV: xx.x°
0F	Intake Air Temperature	IAT: xxx° C (xxx° F)
10	Air Flow Rate from Mass Airflow Sensor	MAF: xxxx.xx g/s (xxxx.x lb/min)
11	Absolute Throttle Position	TP: xxx.x%
13	Location of Oxygen Sensors	O2SLOC: O2Sxx
14	Bank 1-Sensor 1	O2S11: x.xxx V SHRTFT11: xxx.x %
15	Bank 1-Sensor 2	O2S12: x.xxx V
16 <Vehicles for California>	Bank 1-Sensor 3	O2S13: x.xxxV
1C	OBD requirements to which vehicle or engine is certified	OBDSUP: OBD II
1F	Time Since Engine Start	RUNTM: xxxxx sec.
21	Distance Traveled While MIL is Activated	MIL_DIST: xxxxx km (xxxxx miles)
2C	Commanded EGR	EGR_PCT: xxx.x %
2E	Commanded Evaporative Purge	EVAP_PCT: xxx.x %
2F	Fuel Level Input	FLI: xxx.x %
30	Number of warm-ups since DTCs cleared	WARM_UPS: xxx
31	Distance traveled since DTCs cleared	CLR_DIST: xxxxx km (xxxxx miles)
32	Evap System Vapor Pressure	EVAP_VP: xxxx.x Pa (xx.xxx in H2O)
33	Barometric Pressure	BARO: xxx kPa (xx.x inHg)

PARAMETER IDENTIFICATION (PID)	DESCRIPTION	COMMON EXAMPLE OF GENERAL SCAN TOOL DISPLAY	
41	Monitor status this driving cycle		
	Enable status of continuous monitors this monitoring cycle:	Enable status of continuous monitors this monitoring cycle: NO means disable for rest of this monitoring cycle or not supported in PID 01, YES means enable for this monitoring cycle.	
	Misfire monitoring enabled	MIS_ENA: NO or YES	
	Fuel system monitoring enabled	FUEL_ENA: NO or YES	
	Comprehensive component monitoring enabled	CCM_ENA: NO or YES	
	Completion status of continuous monitors this monitoring cycle:	Completion status of continuous monitors this monitoring cycle:	
	Misfire monitoring completed	MIS_COMPL: YES or NO	
	Fuel system monitoring completed	FUELCOMP: YES or NO	
	Comprehensive component monitoring completed	CCM_CMPL: YES or NO	
	Enable status of non-continuous monitors this monitoring cycle:	Enable status of non-continuous monitors this monitoring cycle:	
	Catalyst monitoring	CAT_ENA: YES	
	Heated catalyst monitoring	HCAT_ENA: NO	
	Evaporative system monitoring	EVAP_ENA: YES	
	Secondary air system monitoring	AIR_ENA: NO	
	Oxygen sensor monitoring	O2S_ENA: YES	
	Oxygen sensor heater monitoring	HTR_ENA: YES	
	EGR and/or VVT system monitoring	EGR_ENA: YES	
	Completion status of non-continuous monitors this monitoring cycle:	Completion status of non-continuous monitors this monitoring cycle:	
	Catalyst monitoring completed	CAT_CMPL: YES or NO	
	Heated catalyst monitoring completed	HCATCMPL: YES	
	Evaporative system monitoring completed	EVAPCMPL: YES or NO	
	Secondary air system monitoring completed	AIR_CMPL: YES	
	Oxygen sensor monitoring completed	O2S_CMPL: YES or NO	
	Oxygen sensor heater monitoring completed	HTR_CMPL: YES or NO	
	EGR and/or VVT system monitoring completed	EGR_CMPL: YES or NO	
	42	Control module voltage	VPWR: xx.xx V
	43	Absolute Load Value	LOAD_ABS: xxxxx.x %
	44	Fuel/Air Commanded Equivalence Ratio	LAMBDA: xxx.xxx

PARAMETER IDENTIFICATION (PID)	DESCRIPTION	COMMON EXAMPLE OF GENERAL SCAN TOOL DISPLAY
45	Relative Throttle Position	TP_R: xxx.x %
46	Ambient air temperature	AAT: xxx°C (xxx°F)
47	Absolute Throttle Position B	TP_B: xxx.x %
49	Accelerator Pedal Position D	APP_D: xxx.x %
4A	Accelerator Pedal Position E	APP_E: xxx.x %
4C	Commanded Throttle Actuator Control	TAC_PCT: xxx.x %
5A	Relative Accelerator Pedal Position	APP_R: xxx.x %

### Actuator Test Function

The actuator test items are shown in the following table.

M.U.T.-III SCAN TOOL DISPLAY	ITEM NO.	INSPECTION ITEM	ACTIVATING CONTENT
A/C relay	16	A/C compressor clutch relay	A/C compressor clutch relay turns from OFF to ON
Cooling fan	14	Radiator fan, A/C condenser fan	Drive the fan motor
EVAP. emission purge SOL. valve	10	Evaporative emission purge solenoid	Solenoid valve turns from OFF to ON
EVAP. emission ventilation SOL.	15	Evaporative emission ventilation solenoid	Solenoid valve turns from OFF to ON
Fuel pump	9	Fuel pump	Fuel pump operates and fuel is recirculated
Ignition timing 5 BTDC	11	Basic ignition timing	Set to ignition timing adjustment mode
Injector stop	1	Injectors	Specified injector is stopped
Oil control valve	17	Intake engine oil control valve, exhaust engine oil control valve	Switch the intake engine oil control valve and exhaust engine oil control valve